

# STORAGE IN APPROVED MAGAZINES OF PROPELLING CHARGES PACKED IN CYLINDRICAL METAL CONTAINERS UNITIZED 24 PER 35" X 45-1/2" WOODEN PALLET

## PA 103 SERIES CONTAINER

### INDEX

<u>ITEM</u>	<u>PAGE(S)</u>
GENERAL NOTES - - - - -	2
UNIT DETAIL- - - - -	3
STORAGE PROCEDURES (EARTH COVERED MAGAZINES):	
81'-0", 60'-8" AND 40'-4" L X 26'-6" W X 12'-9" H IGLOO MAGAZINES - -	4,5
81'-2" L X 26'-6" W X 12'-1-3/4" H ARCH TYPE MAGAZINE - - - - -	6,7
80'-0" AND 40'-0" L X 25'-0" W X 12'-1-3/4" H ARCH TYPE MAGAZINES - -	8,9
80'-0" AND 40'-0" L X 25'-0" W X 11'-0" H ARCH TYPE MAGAZINES - - -	10,11
80'-0" AND 40'-0" L X 25'-0" W X 10'-0" H ARCH TYPE MAGAZINES - - -	12,13
80'-0" L X 25'-0" W X 14'-0" H STRADLEY MAGAZINE- - - - -	14,15
89'-0" L X 24'-11" W X 13'-6" H STEEL ARCH MAGAZINE - - - - -	16,17
52'-0" DIA CORBETTA MAGAZINE- - - - -	18,19
100'-8" L X 50'-0" W RECTANGULAR MAGAZINE - - - - -	20,21
TYPICAL MULTIPLE-LOT PROCEDURES:	
IGLOO AND ARCH TYPE MAGAZINES - - - - -	22,23
STRADLEY MAGAZINE - - - - -	24,25
CORBETTA MAGAZINE - - - - -	26,27
RECTANGULAR MAGAZINE- - - - -	28

### U.S. ARMY MATERIEL COMMAND DRAWING

APPROVED. U.S. ARMY INDUSTRIAL OPERATIONS COMMAND <i>NKH</i> <i>David A. Peshock</i> AMSTA-AR-ESK	DRAFTSMAN	INGEBORG DEPPE		
	ENGINEER	M. DAEUMER		
APPROVED BY ORDER OF COMMANDING GENERAL, U.S. ARMY MATERIEL COMMAND <i>W. H. ...</i> DEFENSE AMMUNITION CENTER	SUPPLY ENGINEERING DIVISION			
	LOGISTICS ENGINEERING OFFICE		<i>William J. Ernst</i>	
	SEPTEMBER 1997			
	CLASS	DIVISION	DRAWING	FILE
	19	48	4312/22	1-3-4-14-22 PM1006

DO NOT SCALE

## GENERAL NOTES

- A. THIS DOCUMENT HAS BEEN PREPARED AND ISSUED IN ACCORDANCE WITH AR 740-1 AND AUGMENTS TM 743-2001 (CHAPTER 5).
- B. THE STORAGE PROCEDURES SPECIFIED HEREIN ARE APPLICABLE FOR STORAGE IN VARIOUS TYPES AND SIZES OF MAGAZINES. THE STORAGE PROCEDURES DEPICTED FOR THE SPECIFIC TYPES OF MAGAZINES MAY ALSO BE UTILIZED TO STORE THE DEPICTED PALLET UNITS IN OTHER TYPES OF APPROVED MAGAZINES. MINOR ADJUSTMENTS MAY BE MADE TO FACILITATE STORAGE IN OTHER TYPES OF MAGAZINES, HOWEVER, THE BASIC PRINCIPLES AS DEPICTED HEREIN WILL BE FOLLOWED.
- C. THE STORAGE PROCEDURES SPECIFIED HEREIN ARE APPLICABLE FOR PROPELLING CHARGES PACKED IN THE PA103 CYLINDRICAL METAL CONTAINERS UNITIZED ON A 35" LONG BY 45-1/2" WIDE WOODEN PALLET. SUBSEQUENT REFERENCE TO PALLET UNIT MEANS THE PALLET UNIT WITH AMMUNITION ITEMS.
- D. FOR DETAIL OF THE PALLET UNIT, REFER TO U. S. ARMY AMC DRAWING 19-48-4042A/22-20PM1001 AND THE PICTORIAL VIEW ON PAGE 3.
- E. CAUTION: THE ALLOWABLE "EXPLOSIVE LIMIT" ESTABLISHED FOR A MAGAZINE IS NOT TO BE EXCEEDED. THIS LIMITATION MAY REQUIRE A QUANTITY REDUCTION FROM THE STORAGE AS SHOWN.
- F. STORED PALLET UNITS MUST NOT CONTACT THE WALLS OF A MAGAZINE. THEREFORE, UNITS WILL BE STORED A MINIMUM OF SIX INCHES (6") FROM THE SIDEWALL OR THE CURVATURE OF THE MAGAZINE AS APPLICABLE. TO PROVIDE FOR THIS MANDATORY CLEARANCE REQUIREMENT, UNITS MAY BE ELIMINATED FROM THE DEPICTED STORAGE PATTERNS AS NECESSARY.
- G. AISLE DIMENSIONS SHOWN FOR STORAGE PROCEDURES IN MAGAZINES MAY BE ADJUSTED TO SUIT LOCAL CONDITIONS, VARIATIONS IN PALLET UNIT DIMENSIONS, AND/OR AVAILABLE MATERIALS HANDLING EQUIPMENT.
- H. THE MAXIMUM FLOOR LOAD FOR A MAGAZINE AS PRESCRIBED BY LOCAL STANDARDS WILL NOT BE EXCEEDED.
- J. THE HEIGHT OF THE PACKAGE GUARD ON SOME FORKLIFT TRUCKS MAY NOT PERMIT PLACEMENT OF SOME TOP LAYER UNITS IN THE STACKS SHOWN IN THE STORAGE VIEWS HEREIN, UNLESS TWO UPPER PALLET UNITS ARE HANDLED AS ONE LIFT OR THE PACKAGE GUARD IS REMOVED (THE CARRIAGE WILL IN MOST INSTANCES PROVIDE ADEQUATE PACKAGE GUARD PROTECTION). ONLY A FORKLIFT TRUCK OF ADEQUATE CAPACITY WILL BE USED WHEN LIFTING TWO PALLET UNITS AS ONE LIFT.
- K. THE MATERIAL HANDLING EQUIPMENT (MHE) AREA SHOULD BE OF SUFFICIENT DIMENSION TO PERMIT "TURNAROUND" OF MHE WHEN STORING IN MAGAZINE NOT EQUIPPED WITH PROPERLY SIZED APRONS FOR THAT PURPOSE. THE MHE AISLE IN ALL MAGAZINES IS BASED ON A FIGURE WHICH IS AT LEAST 7'-7" PLUS THE LENGTH OR WIDTH OF THE PALLET UNIT, AS APPLICABLE, OR THE LENGTH OF THE FORKLIFT TINES (40"), WHICHEVER IS THE GREATEST. IF THE AVAILABLE MHE PERMITS, ADDITIONAL PALLET UNITS MAY BE STORED WITHIN THE MHE AREA AND/OR OTHER AVAILABLE AREA IN THE MAGAZINE.
- L. CONVERSION TO METRIC EQUIVALENTS: DIMENSIONS WITHIN THIS DOCUMENT ARE EXPRESSED IN INCHES, AND WEIGHTS ARE EXPRESSED IN POUNDS. WHEN NECESSARY, THE METRIC EQUIVALENT MAY BE COMPUTED ON THE BASIS OF ONE INCH EQUALS 25.4MM, AND ONE POUND EQUALS 0.454KG.
- M. STORAGE OF MULTIPLE LOTS IN A MAGAZINE WILL REQUIRE CAREFUL PREPLANNING SO AS TO INSURE MHE ACCESSIBILITY TO ANY LOT IN ACCORDANCE WITH REQUIREMENTS SET FORTH IN THE APPLICABLE "SPECIAL NOTES" SECTIONS OF THE MULTIPLE-LOT STORAGE PROCEDURES TYPICALLY SHOWN ON PAGES 22 THRU 28.

## (GENERAL NOTES CONTINUED)

- N. ALTHOUGH SPECIFIC PROCEDURES ARE INCLUDED IN THIS DRAWING FOR STORING MULTIPLE LOTS WITHIN ONE STRUCTURE, THE BASIC STORAGE PATTERN AS SHOWN ON PAGES 4 THRU 21 CAN ALSO BE ADAPTED FOR THE STORING OF MORE THAN ONE LOT. LOTS WHEN STORED IN ACCORDANCE WITH A BASIC STORAGE PATTERN MAY BE STORED WITH ONE OR MORE ROWS USED FOR EACH LOT. A SPACE OF APPROXIMATELY 1" WILL HAVE TO BE LEFT BETWEEN ADJACENT ROWS CONTAINING DIFFERENT LOTS. IN BASIC STORAGE PATTERNS WHERE THE WIDTH OF A ROW IS ESTABLISHED BY THE 48" UNIT DIMENSION, EACH ROW MAY BE A DIFFERENT LOT AND BE READILY REMOVABLE. IN BASIC STORAGE PATTERNS WHERE THE WIDTH OF A ROW IS ESTABLISHED BY THE 38" UNIT DIMENSION, A LOT MUST CONSIST OF TWO OR MORE ROWS TO PROVIDE ADEQUATE SPACE TO ACCOMMODATE THE WIDTH OF A FORKLIFT TRUCK FOR STORING OR REMOVING THE LOT. HOWEVER, WHEN THE SIZE OF A LOT REQUIRES THE SPACE OF ONLY ONE ROW, IT IS PERMISSIBLE TO STORE THAT LOT WITH THE 48" DIMENSION ESTABLISHING THE WIDTH OF THAT ROW, PROVIDING THE STORAGE PRINCIPLES SPECIFIED ARE FOLLOWED AS CLOSELY AS POSSIBLE. THE 1" SPACE BETWEEN LOTS, AS STATED ABOVE, WILL NOT BE EXCEEDED SOLELY TO ACCOMMODATE THE WIDTH OF A FORKLIFT TRUCK. FOR ADDITIONAL REQUIREMENTS AND GUIDANCE, SEE THE SPECIAL NOTES FOR MULTIPLE LOT STORAGE ON PAGES 22 THRU 28.
- O. ANY "LIGHT" PALLET UNIT THAT DOES NOT CONTAIN A FULL QUANTITY OF CONTAINERS WILL NOT BE BURIED IN STORAGE. IT MUST BE POSITIONED ADJACENT TO AN AISLE, PREFERABLY IN FRONT OF THE LOT.
- P. PORTIONS OF THE MAGAZINES, SUCH AS SIDEWALLS, END WALLS, AND ROOFS, HAVE NOT BEEN SHOWN IN THE STORAGE VIEWS FOR CLARITY PURPOSES.
- Q. A PRODUCTION OR STORAGE FACILITY IS AUTHORIZED TO HAVE ONE INCOMPLETE, UN-BANDED PARTIAL UNIT LOAD PER LOT IN A STORAGE STRUCTURE. PRIOR TO SHIPMENT OF A PARTIAL UNIT, A LAYER MUST BE COMPLETED, IF APPLICABLE, BY THE POSITIONING OF ONE OR MORE FILLERS AS DELINEATED BY DRAWING 19-48-4042A/22-20PM1001. THE UNIT MUST THEN BE RE-BANDED WITH THE SAME SIZE AND QUANTITY OF STRAPS AS THE ORIGINAL UNIT.
- R. WHEN LOCAL STORAGE CONDITIONS ARE SUCH THAT AN AMMUNITION STORAGE MAGAZINE NET EXPLOSIVE LIMIT WILL BE REACHED BEFORE ALL AVAILABLE STORAGE SPACE WILL BE UTILIZED, A COMBINATION OF THE VARIOUS STORAGE PATTERNS DELINEATED HEREIN MAY BE USED IN LIEU OF BLOCK STORAGE PATTERNS TO FACILITATE INVENTORY, INSPECTION, THE USE OF MATERIAL HANDLING EQUIPMENT, SURVEILLANCE, ETC., OF THE AMMUNITION TO BE STORED WITHIN THE MAGAZINE.
- S. PALLET UNITS PRESENTLY STORED IN ACCORDANCE WITH A PRIOR APPROVED DRAWING NEED NOT BE RE-STORED SOLELY TO CONFORM TO THE PROCEDURES SPECIFIED IN THIS DOCUMENT.

(CONTINUED AT RIGHT)

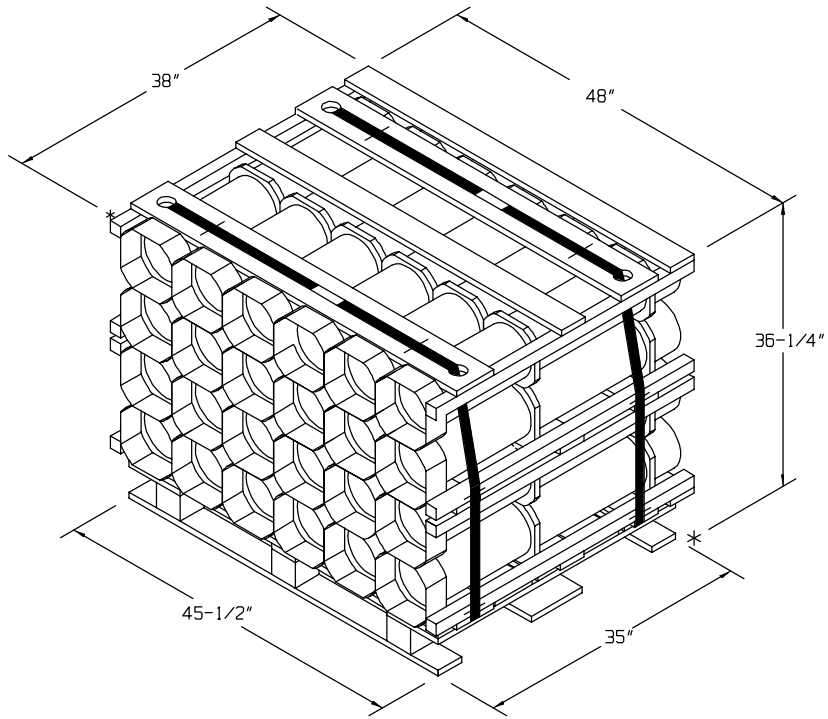

PA 103 CONTAINER, 24 PER PALLET

GROSS WEIGHT - - - - - 1,370 POUNDS (APPROX)  
 CUBE - - - - - 38.3 CUBIC FEET (APPROX)

UNIT DETAIL

**STORAGE IN 81'-0" IGL00**

(12'-9" HIGH)

ITEM	QUANTITY
PALLET UNITS - - - - -	361

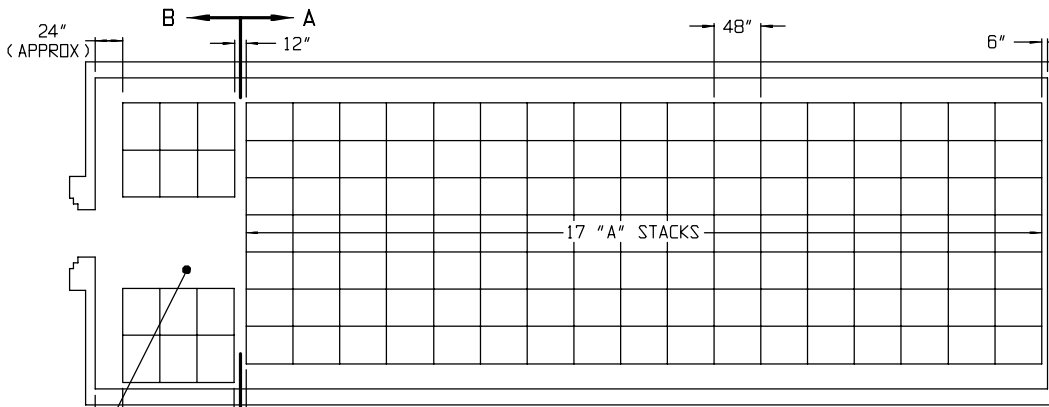

**PLAN VIEW**  
(81'-0" IGL00)

SEE GENERAL NOTE "K" ON PAGE 2.

SEE GENERAL NOTE "F" ON PAGE 2.

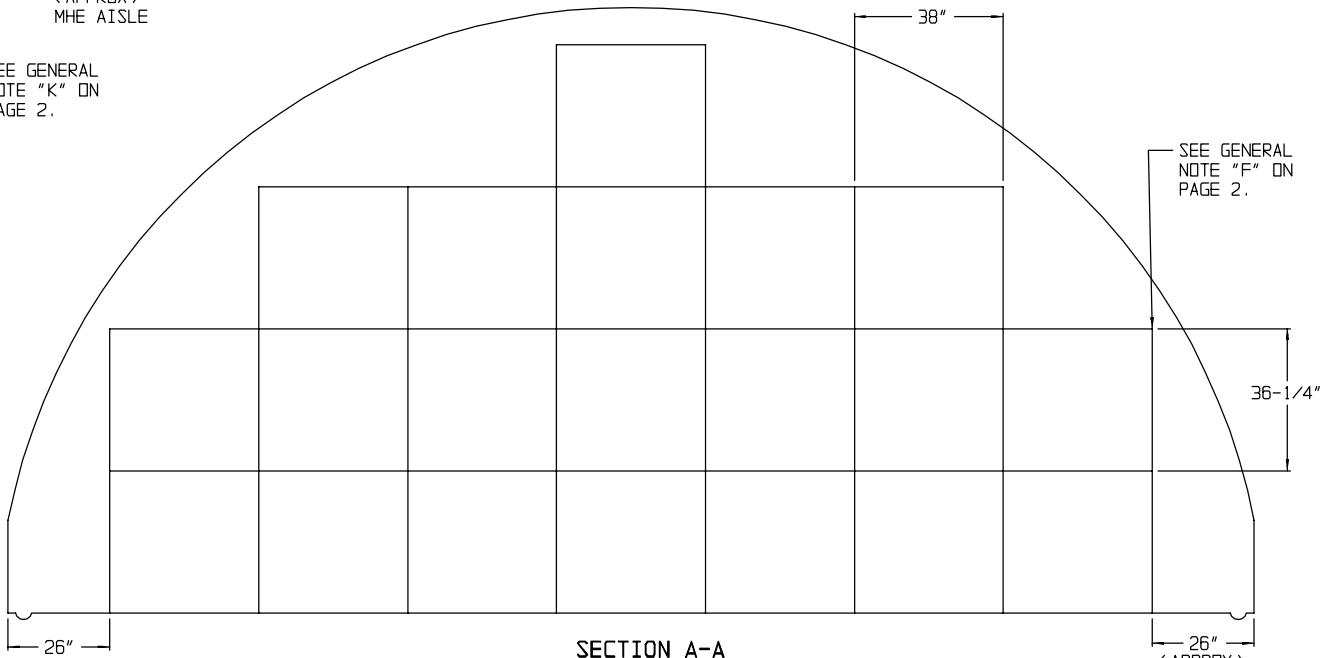

**SECTION A-A**

( "A" STACK, 20 PALLET UNITS )

INDICATES OUTLINE OF DOOR OPENING.

SEE GENERAL NOTE "F" ON PAGE 2.

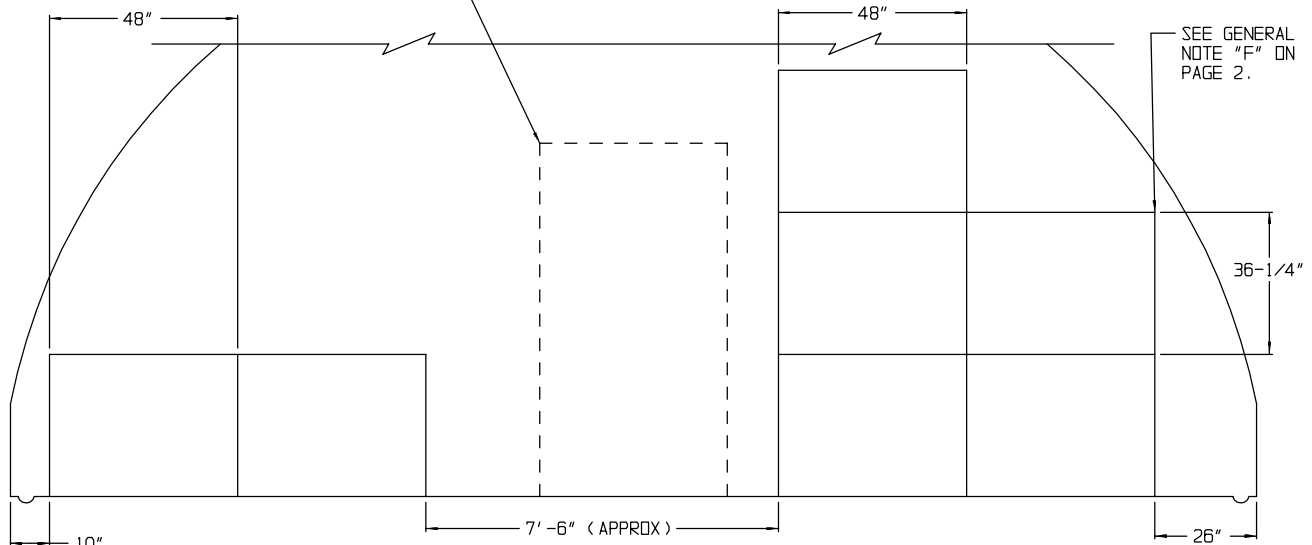

**SECTION B-B**

( "C" STACK, 7 PALLET UNITS )

**STORAGE IN 60'-8" IGL00**

(12'-9" HIGH)

ITEM	QUANTITY
PALLET UNITS - - - - -	261

**\*STORAGE IN 40'-4" IGL00**

(12'-9" HIGH)

ITEM	QUANTITY
PALLET UNITS - - - - -	161

- \* 7 "A" STACKS
- 3 "C" STACKS

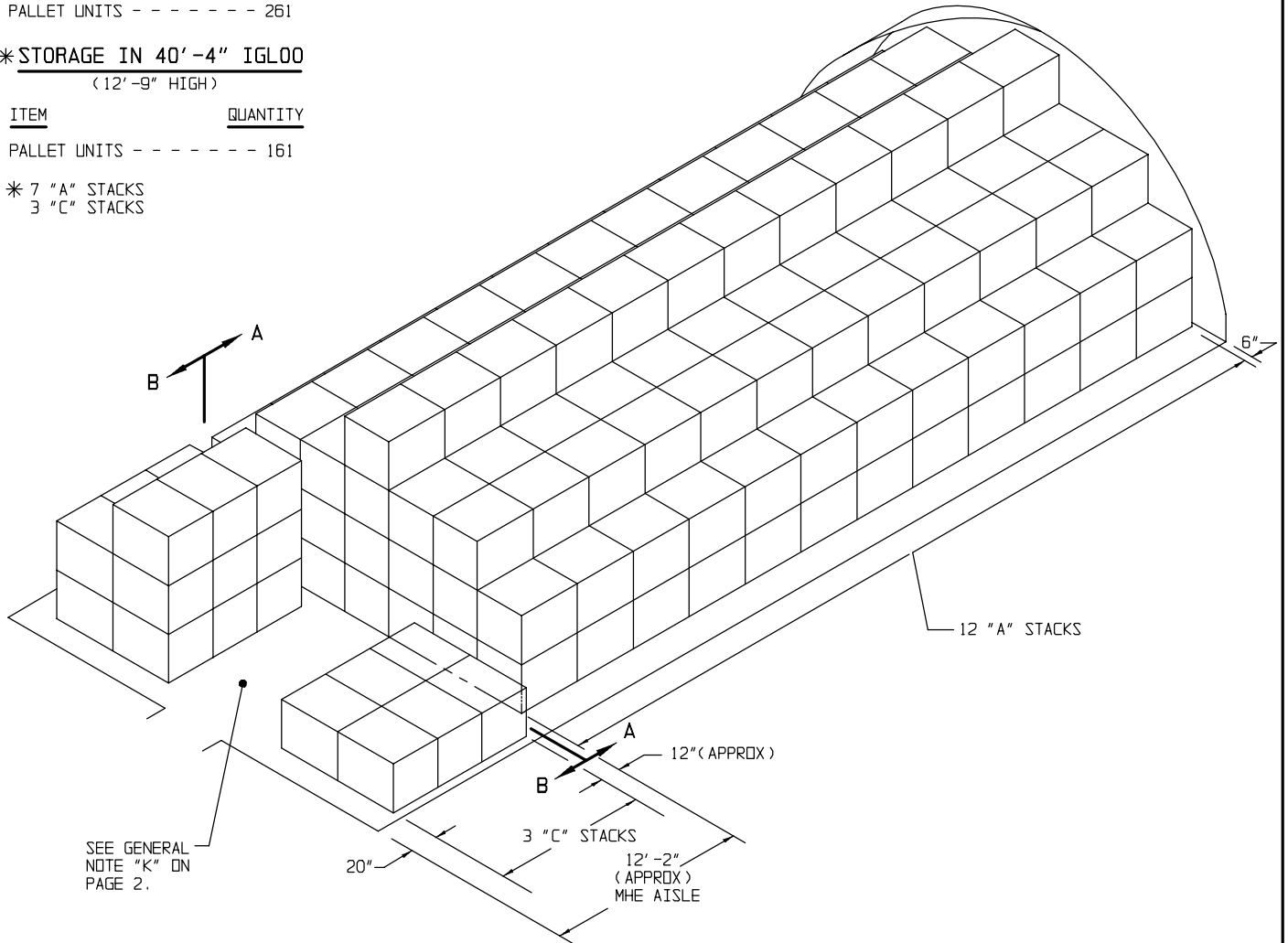

**ISOMETRIC VIEW**  
(60'-8" IGL00)

FOR "GENERAL NOTES", SEE PAGE 2.

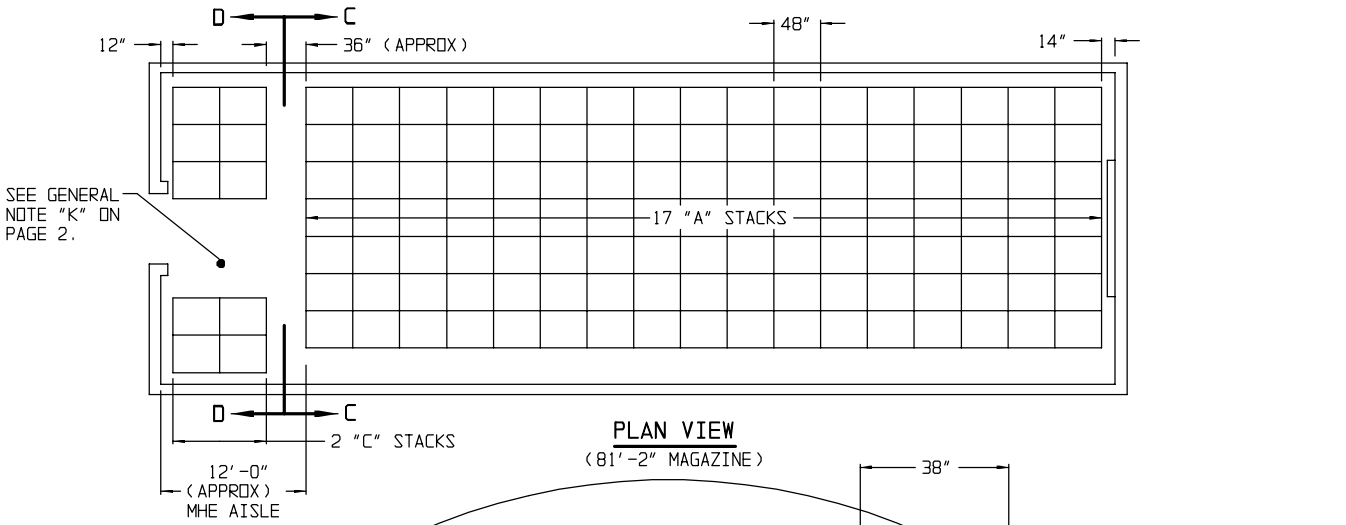

**PLAN VIEW**  
(81'-2" MAGAZINE)

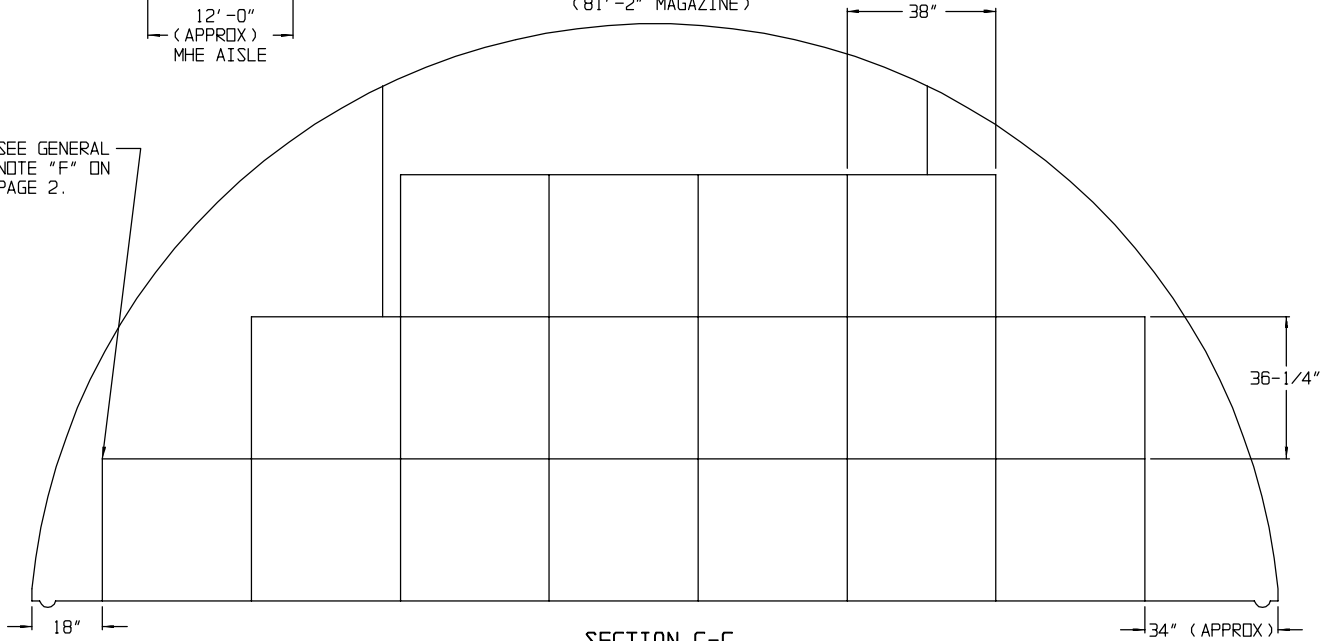

**SECTION C-C**  
( "A" STACK, 17 PALLET UNITS )

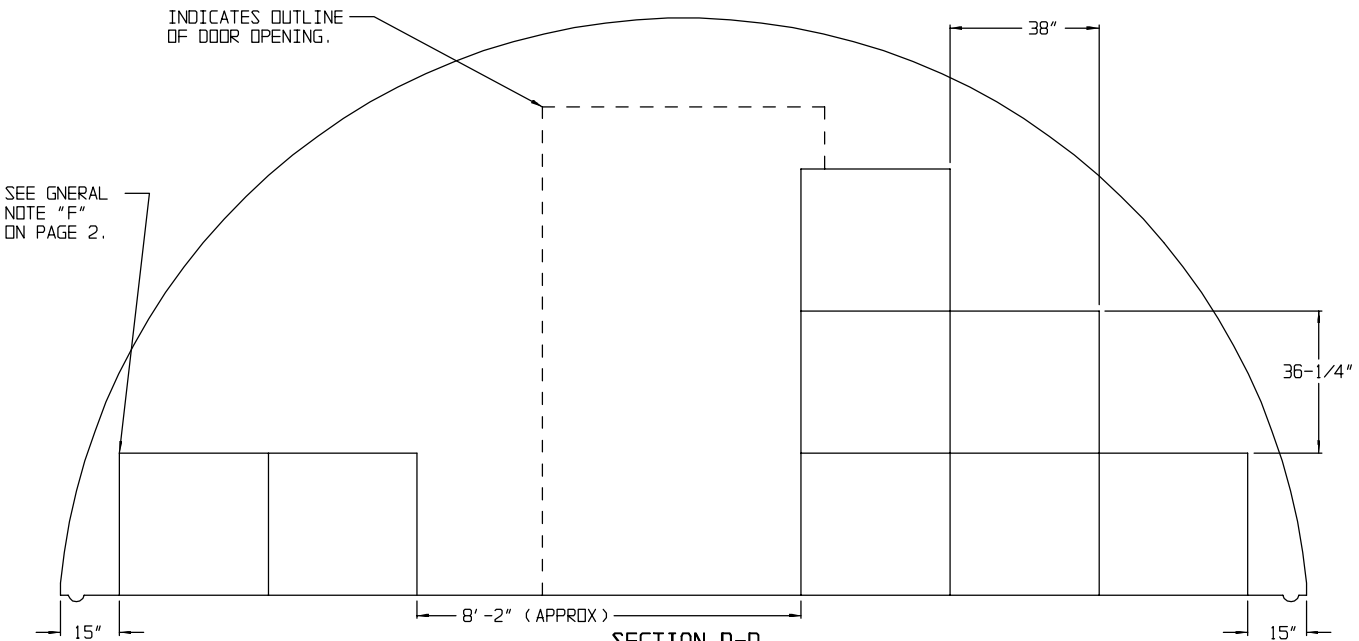

**SECTION D-D**  
( "C" STACK, 8 PALLET UNITS )

STORAGE IN 81'-2" MAGAZINE

(12'-1-3/4" HIGH)

ITEM

QUANTITY

PALLET UNITS - - - - - 305

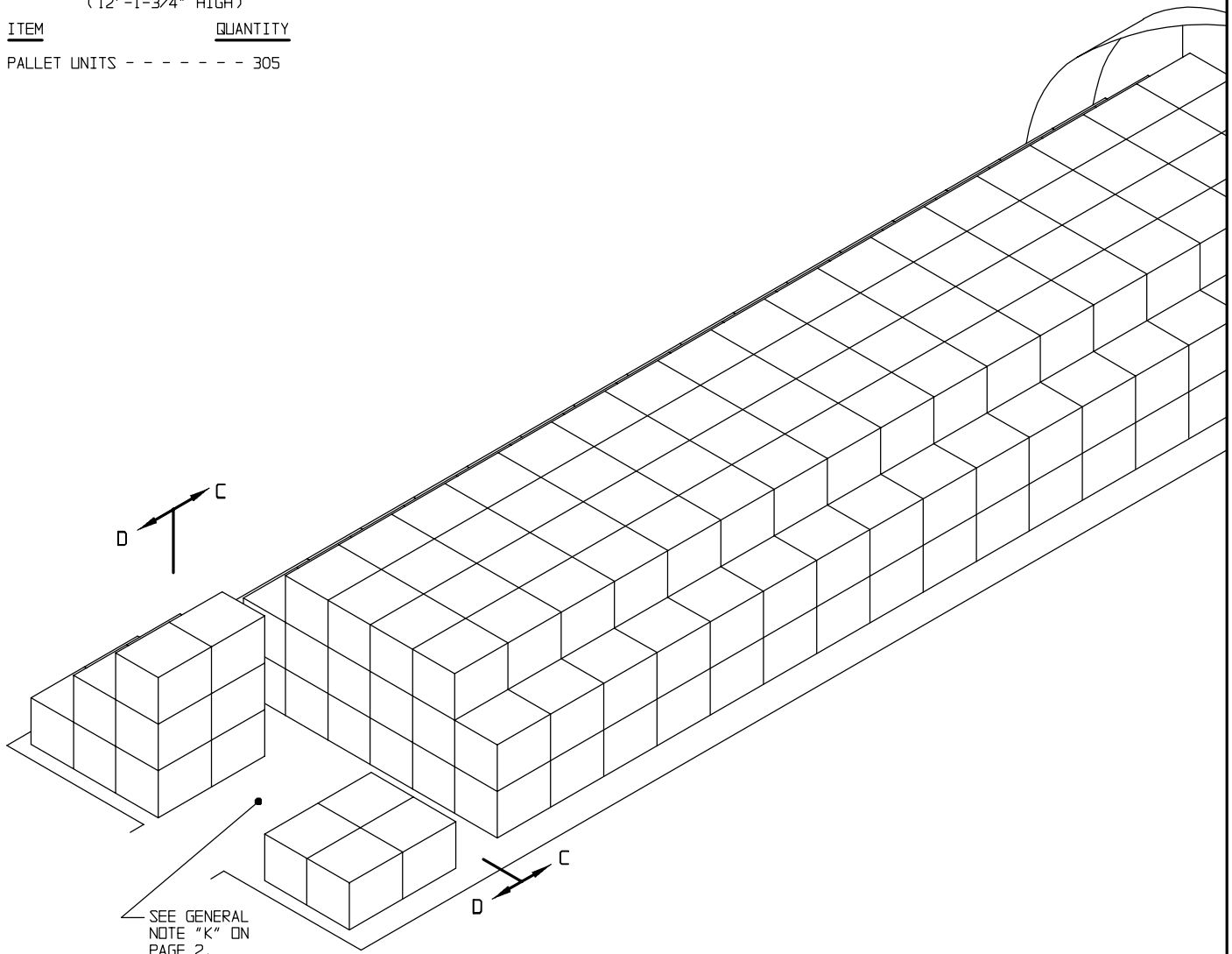

ISOMETRIC VIEW  
(81'-2" MAGAZINE)

FOR "GENERAL NOTES" SEE PAGE 2.

STORAGE IN 80'-0" MAGAZINE  
(12'-1-3/4" HIGH)

ITEM	QUANTITY
PALLET UNITS - - - - -	296

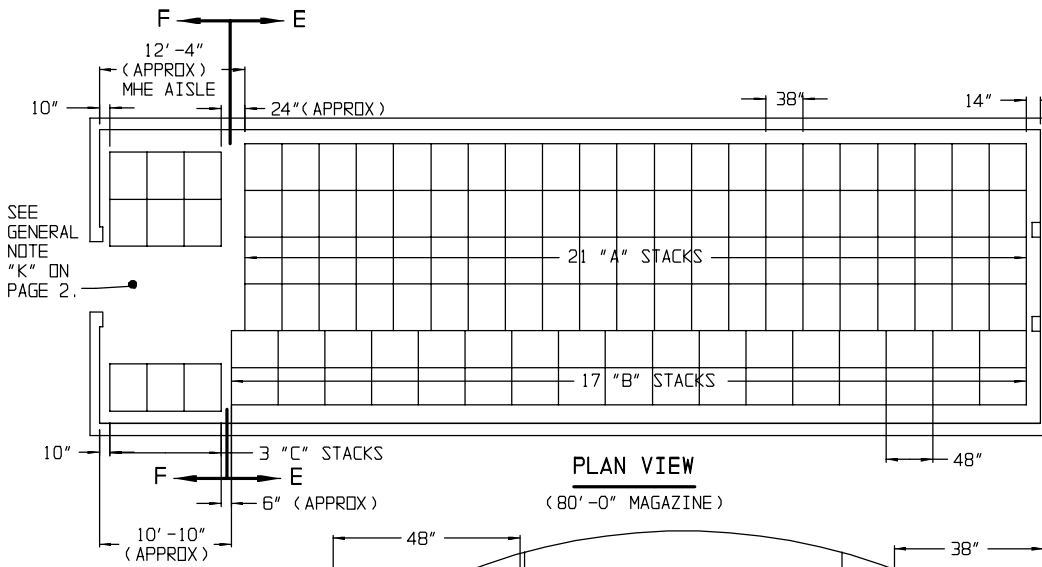

**PLAN VIEW**  
(80'-0" MAGAZINE)

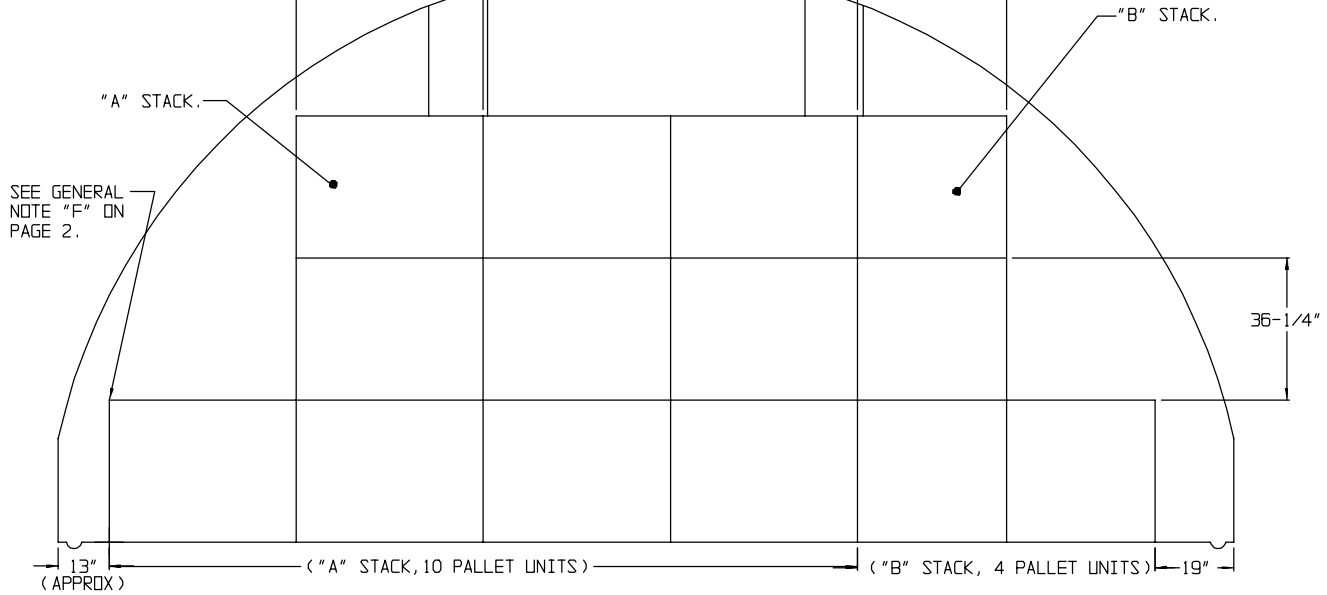

**SECTION E-E**

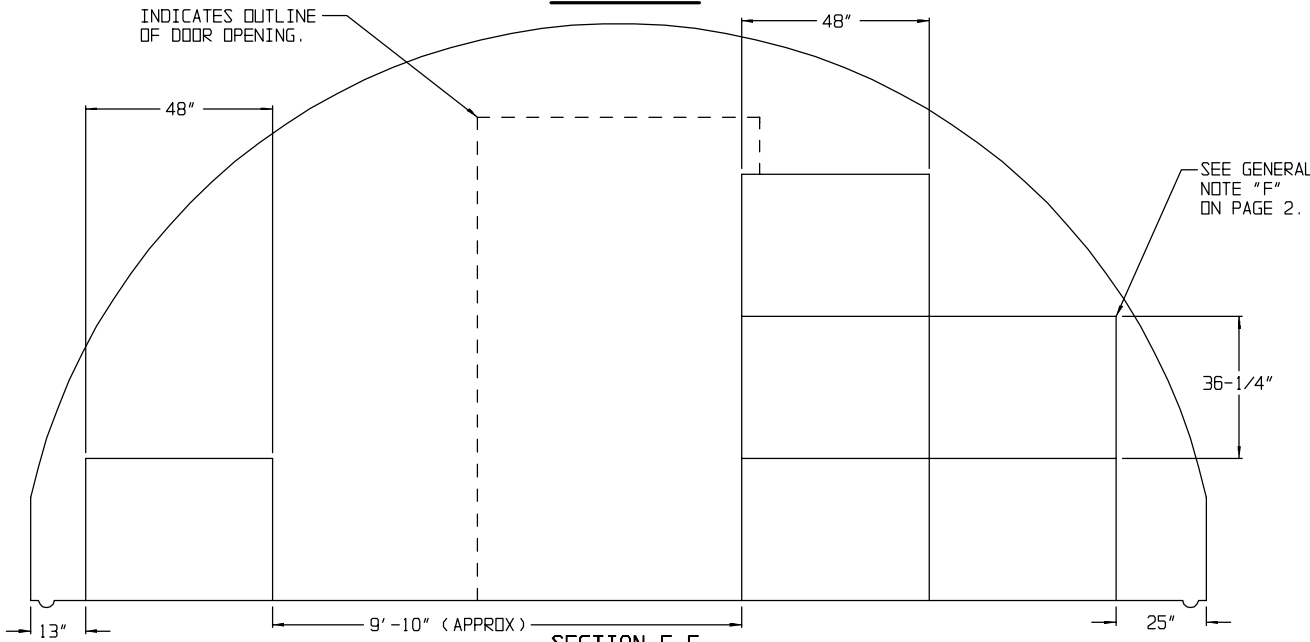

**SECTION F-F**  
( "C" STACK, 6 PALLET UNITS )



**STORAGE IN 40'-0" MAGAZINE**

(12'-1-3/4" HIGH)

ITEM

QUANTITY

PALLET UNITS - - - - - 136

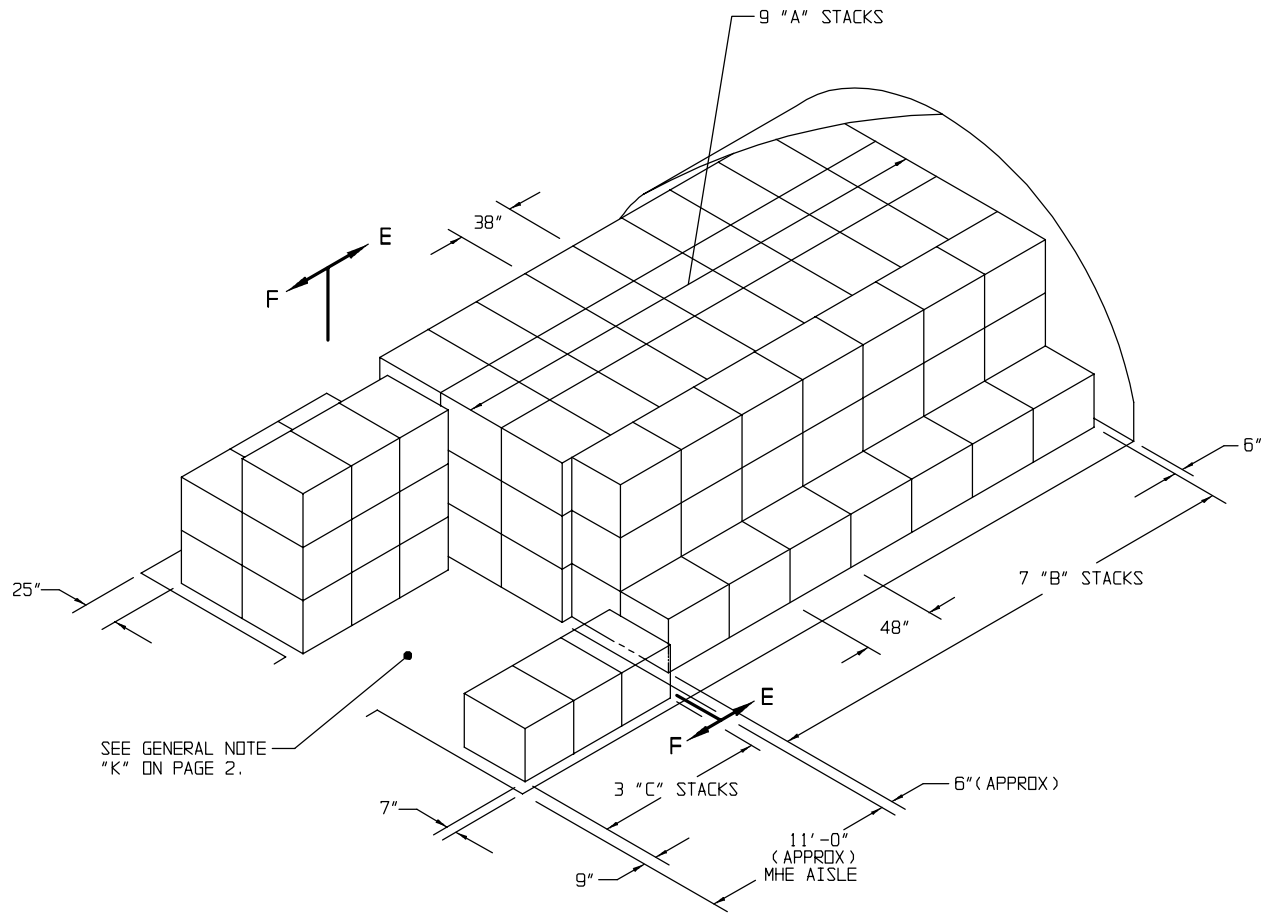

**ISOMETRIC VIEW**

(40'-0" MAGAZINE)

FOR "GENERAL NOTES" SEE PAGE 2.

**STORAGE IN 80'-0" MAGAZINE**

(11'-0" HIGH)

ITEM	QUANTITY
PALLET UNITS	----- 269

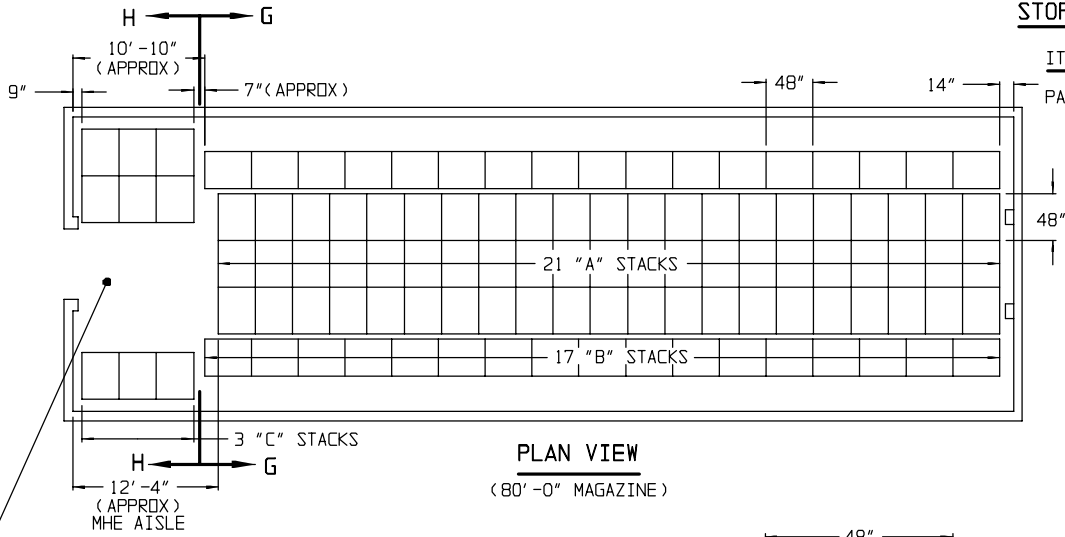

**PLAN VIEW**  
(80'-0" MAGAZINE)

SEE GENERAL NOTE "K" ON PAGE 2.

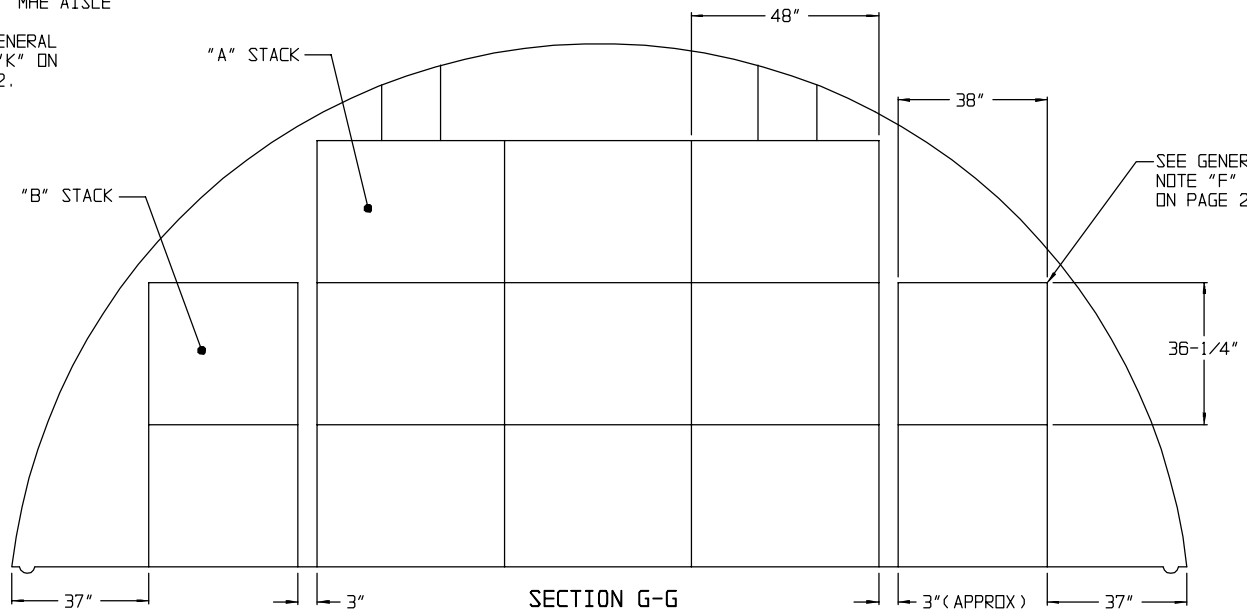

**SECTION G-G**

("A" STACK, 9 PALLET UNITS; "B" STACK, 4 PALLET UNITS)

SEE GENERAL NOTE "F" ON PAGE 2.

INDICATES OUTLINE OF DOOR OPENING.

SEE GENERAL NOTE "F" ON PAGE 2.

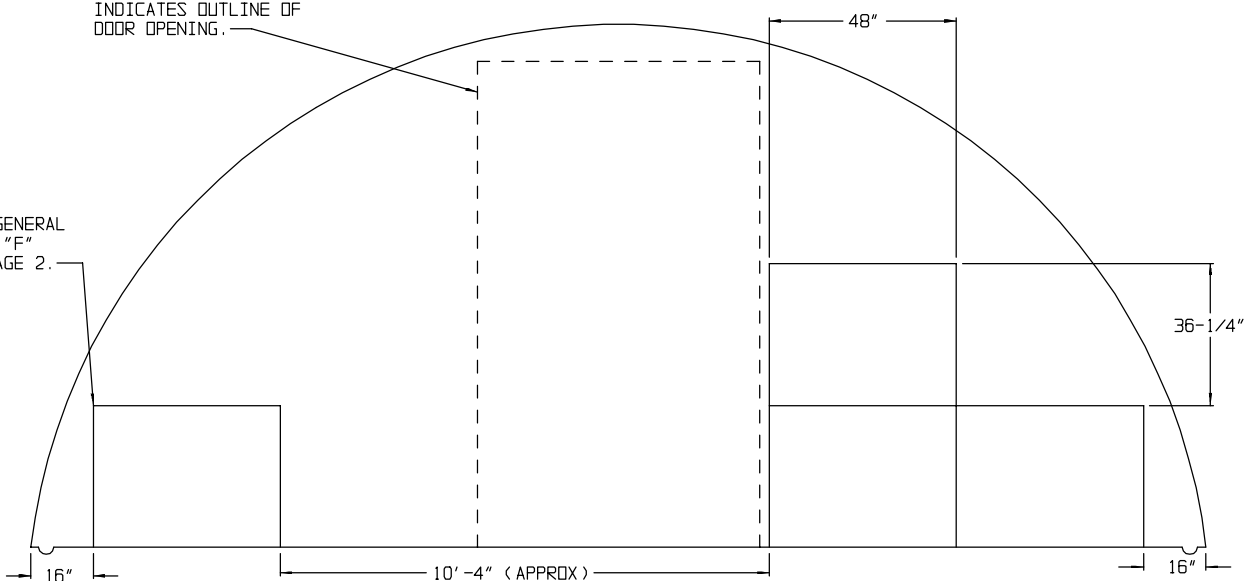

**SECTION H-H**

("C" STACK, 4 PALLET UNITS)

**STORAGE IN 40'-0" MAGAZINE**

(11'-0" HIGH)

ITEM	QUANTITY
PALLET UNITS - - - - -	112

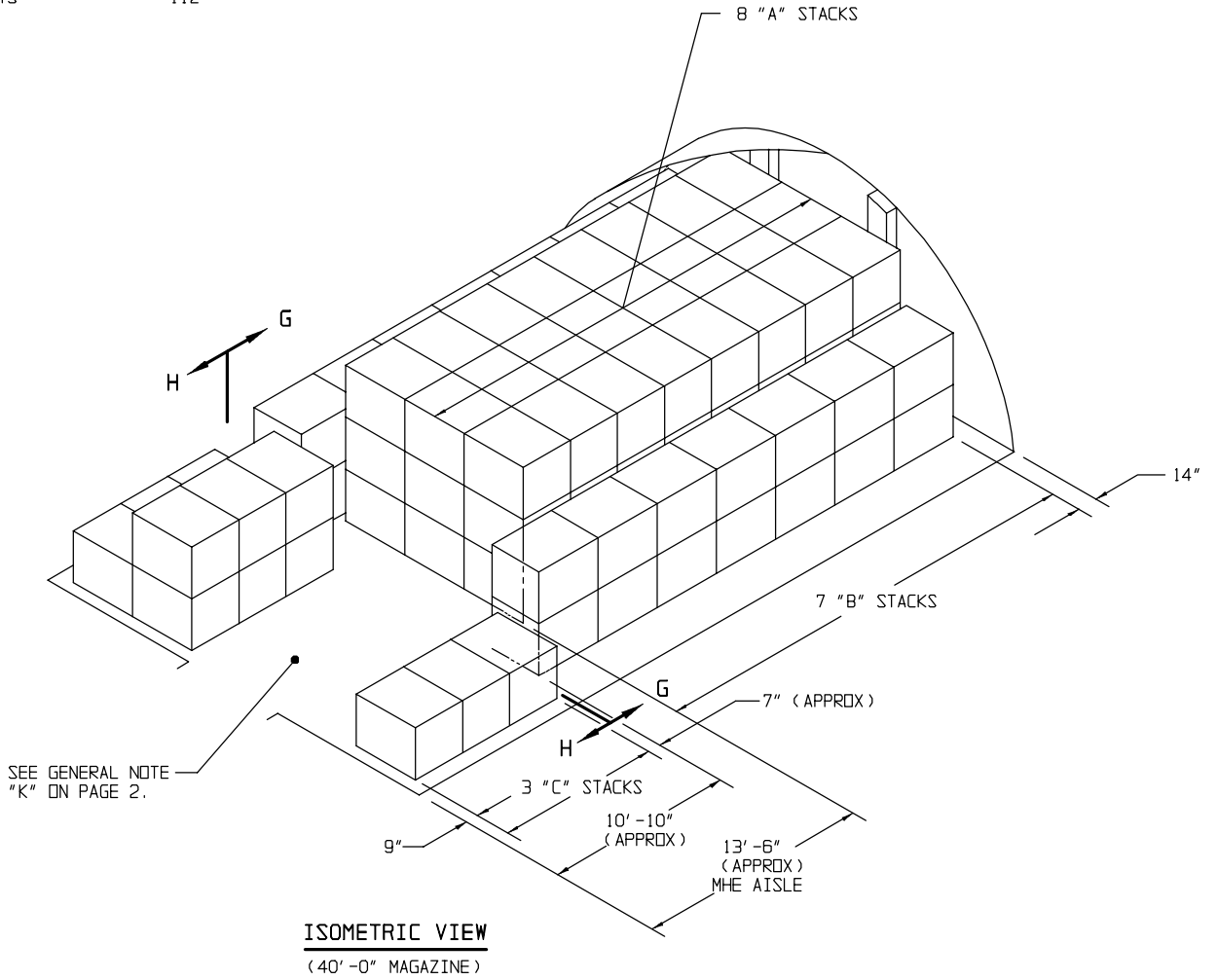

FOR "GENERAL NOTES" SEE PAGE 2.

**STORAGE IN 80'-0" MAGAZINE**  
(10'-0" HIGH)

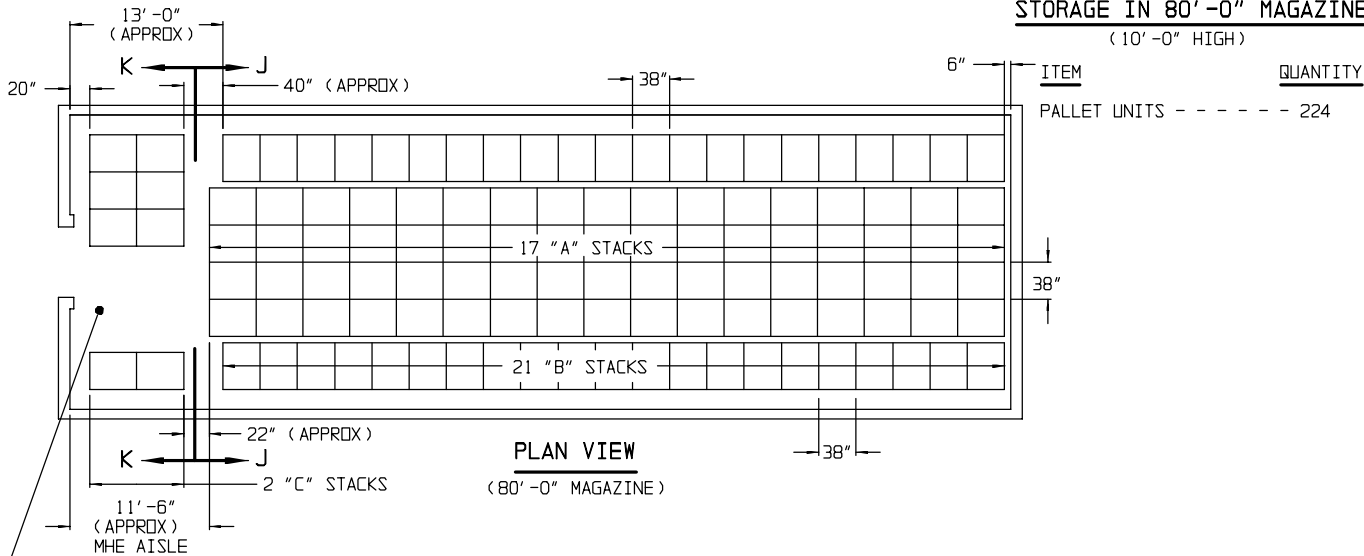

SEE GENERAL NOTE "K" ON PAGE 2.

SEE GENERAL NOTE "F" ON PAGE 2.

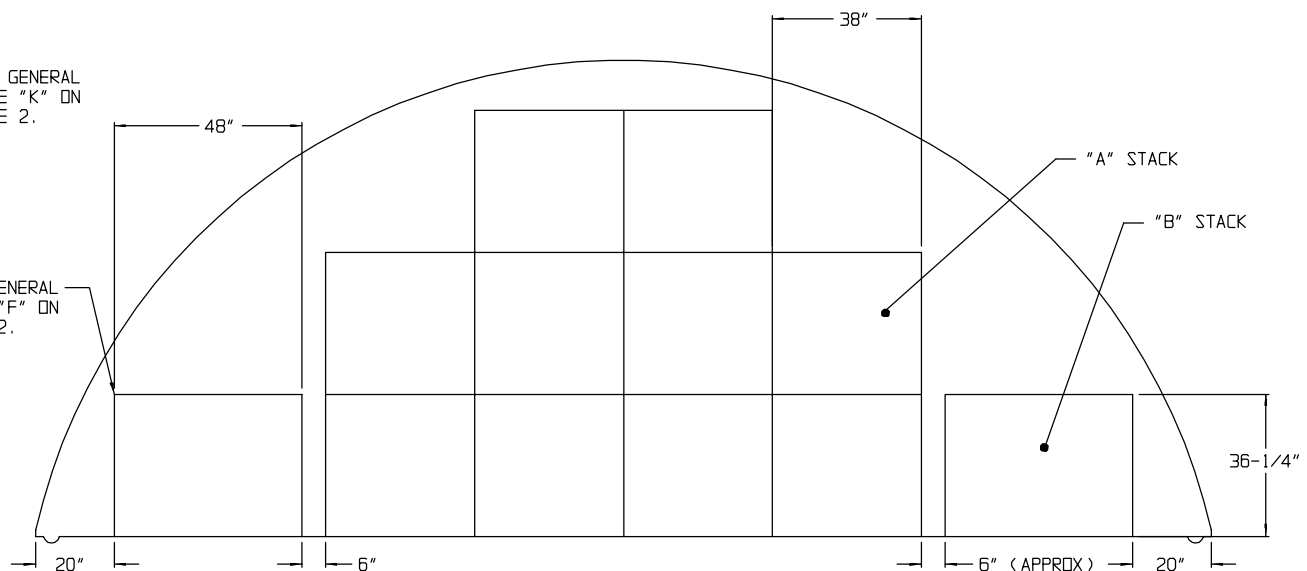

INDICATES OUTLINE OF DOOR OPENING.

SEE GENERAL NOTE "F" ON PAGE 2.

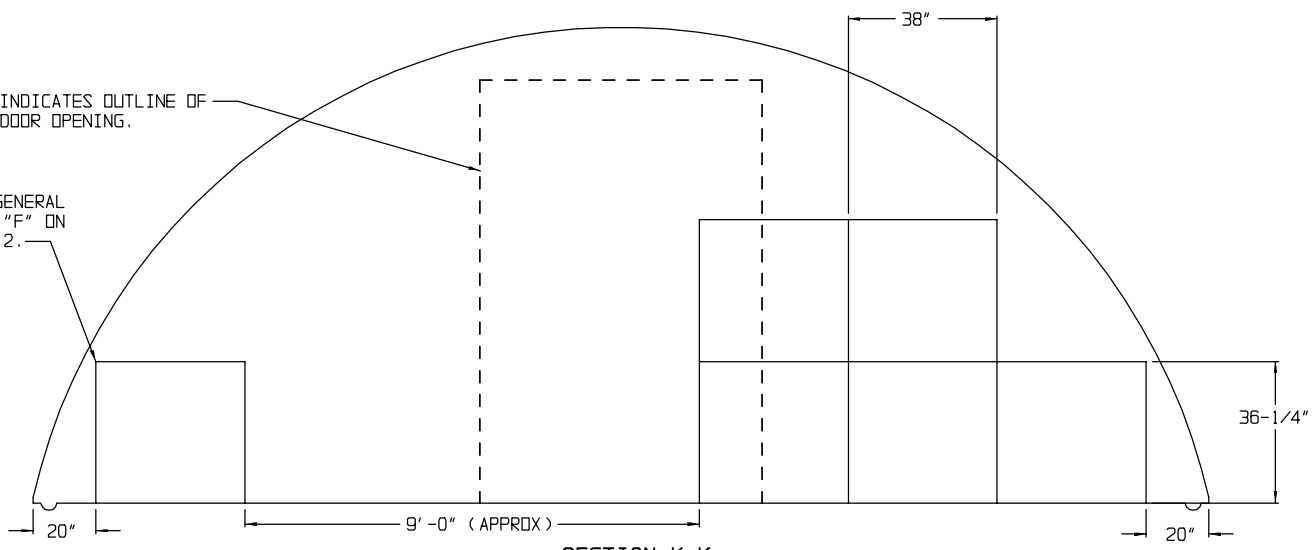

**STORAGE IN 40'-0" MAGAZINE**

(10'-0" HIGH)

<u>ITEM</u>	<u>QUANTITY</u>
PALLET UNITS - - - - -	100

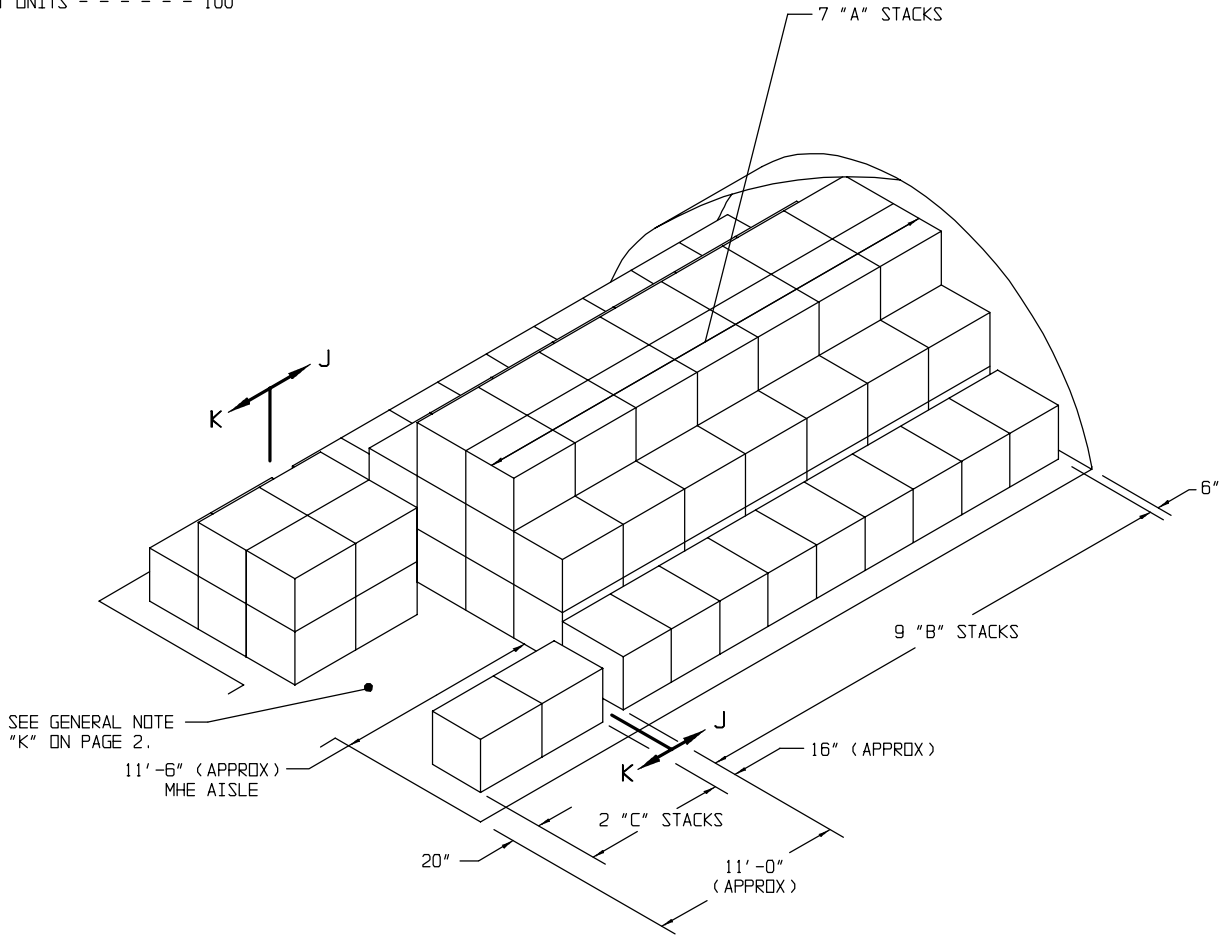

**ISOMETRIC VIEW**  
(40'-0" MAGAZINE)

FOR "GENERAL NOTES", SEE PAGE 2.

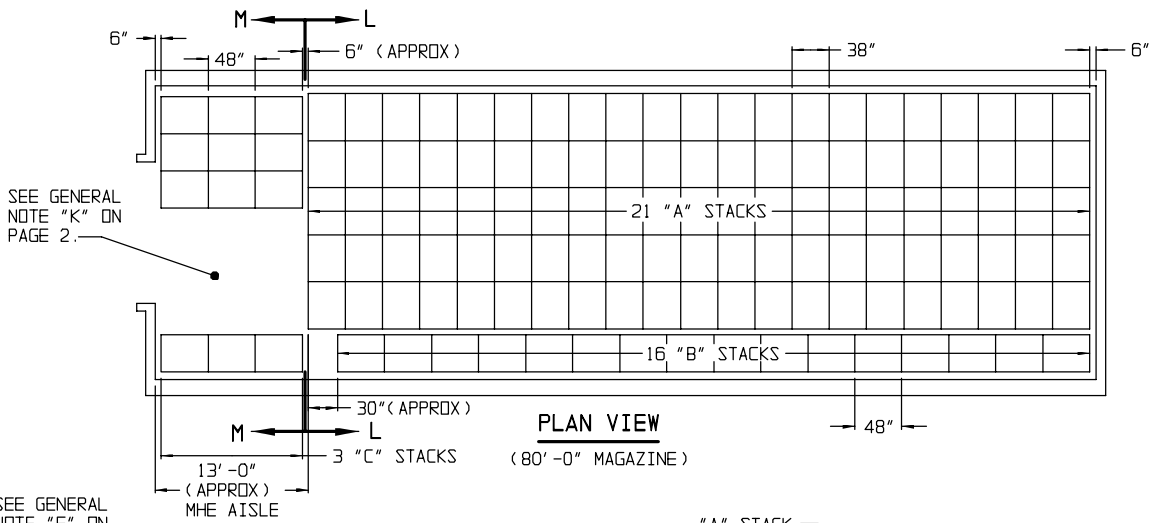

SEE GENERAL NOTE "F" ON PAGE 2.

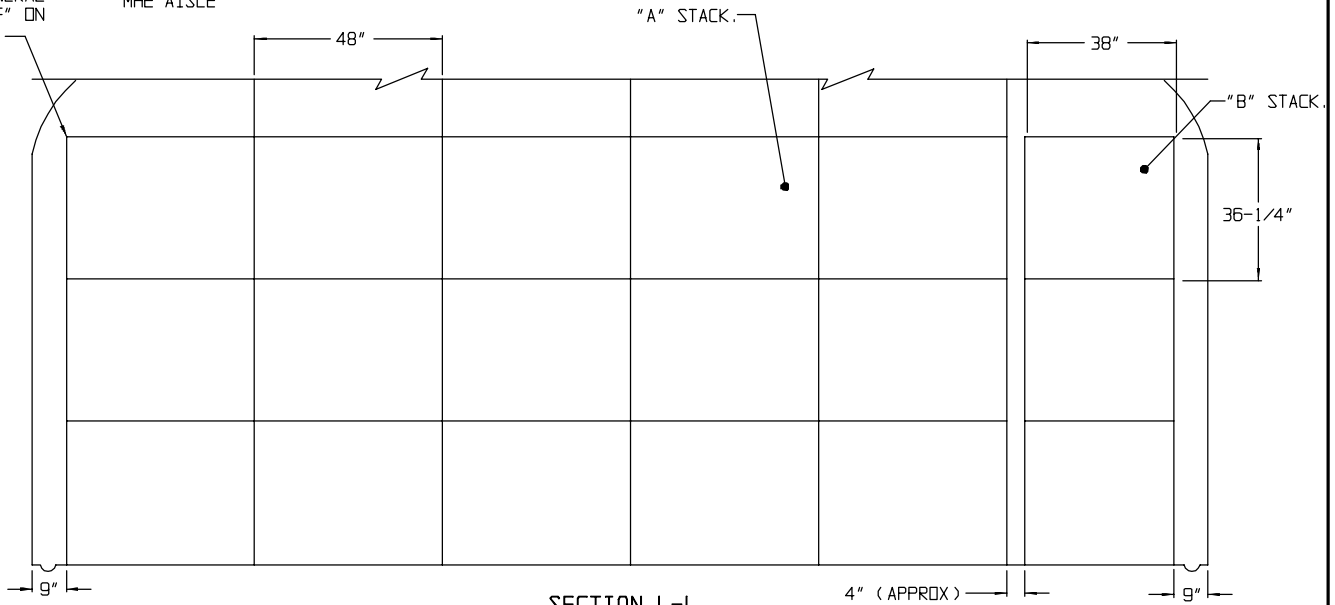

("A" STACK, 19 PALLET UNITS  
"B" STACK, 3 PALLET UNITS)

SEE GENERAL NOTE "F" ON PAGE 2.

INDICATES OUTLINE OF DOOR OPENING.

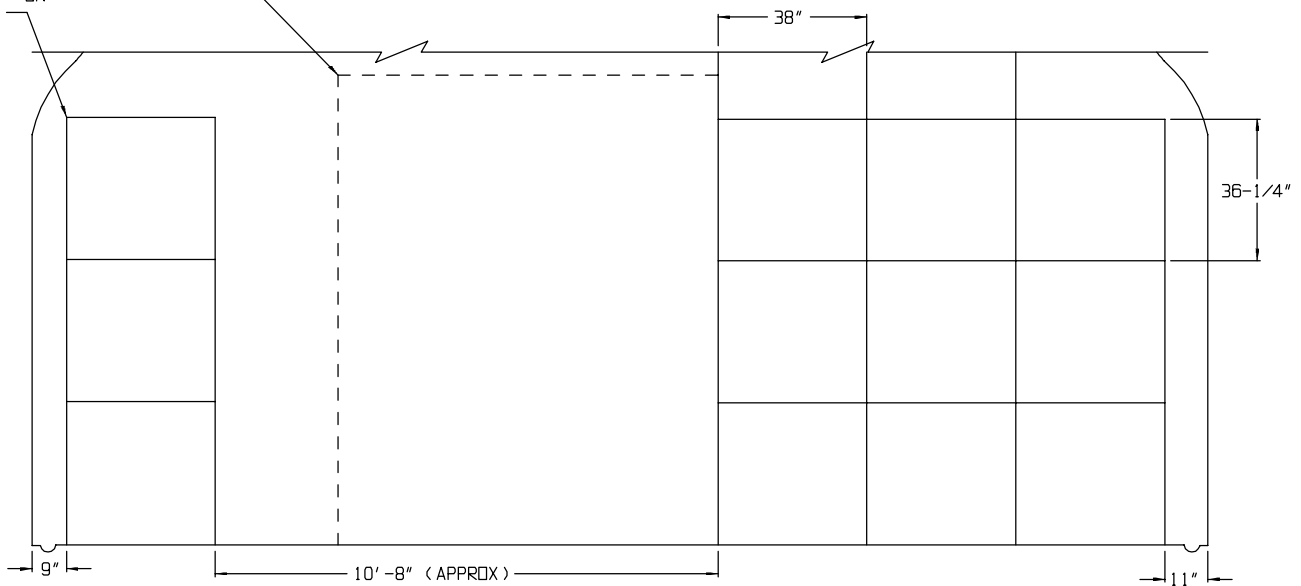

("C" STACK, 14 PALLET UNITS)

STORAGE PROCEDURES IN 80'-0" L X 25'-0" W X 14'-0" H STRADLEY MAGAZINE

STORAGE IN 80'-0" MAGAZINE

(14'-0" HIGH)

ITEM                      QUANTITY \*

PALLET UNITS - - - - - 489

\*CAUTION: SEE GENERAL NOTE "E" ON PAGE 2.

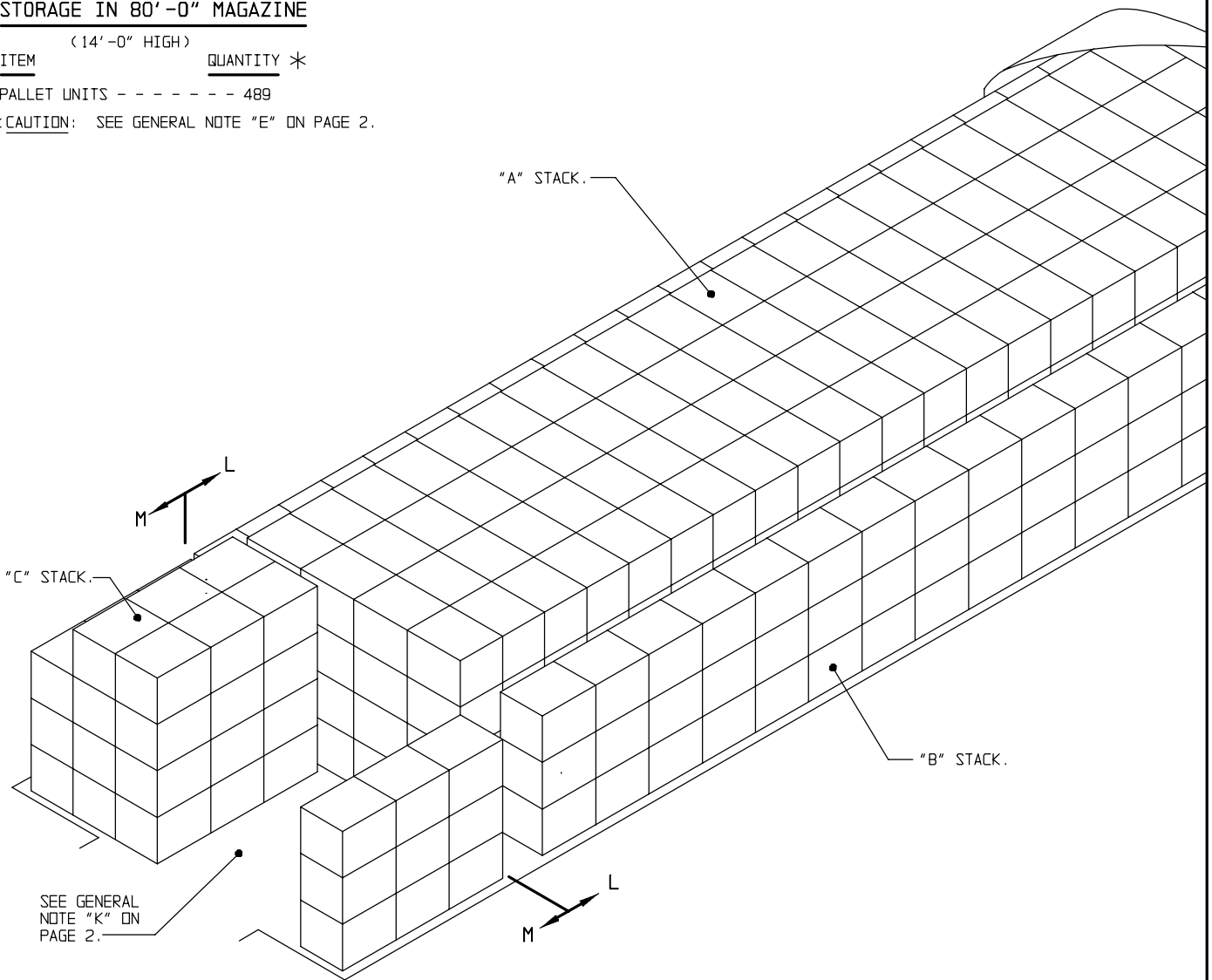

"C" STACK.

"A" STACK.

"B" STACK.

SEE GENERAL  
NOTE "K" ON  
PAGE 2.

FOR "GENERAL NOTES", SEE PAGE 2.

ISOMETRIC VIEW

(80'-0" MAGAZINE)

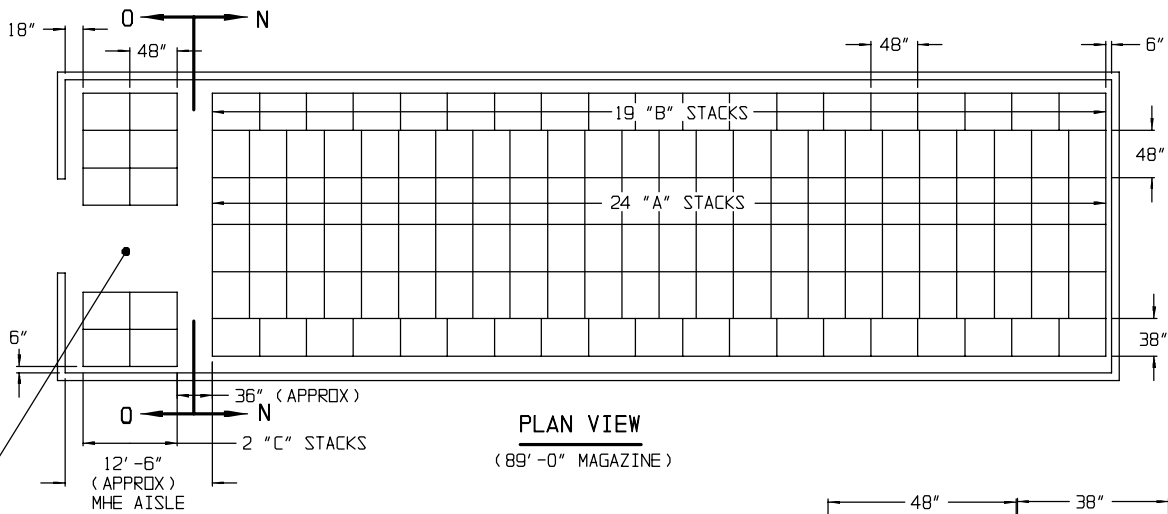

**PLAN VIEW**  
(89'-0" MAGAZINE)

SEE GENERAL NOTE "K" ON PAGE 2.

SEE GENERAL NOTE "F" ON PAGE 2.

"B" STACK.

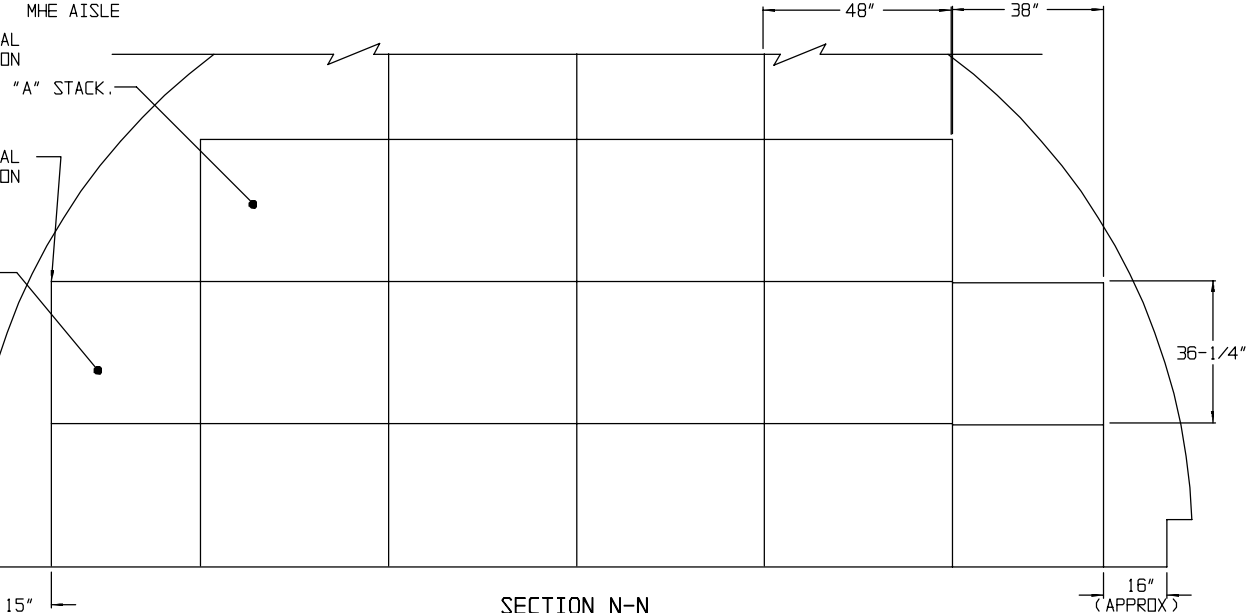

**SECTION N-N**

("A" STACK, 14 PALLET UNITS; "B" STACK, 4 PALLET UNITS)

INDICATES OUTLINE OF DOOR OPENING.

SEE GENERAL NOTE "F" ON PAGE 2.

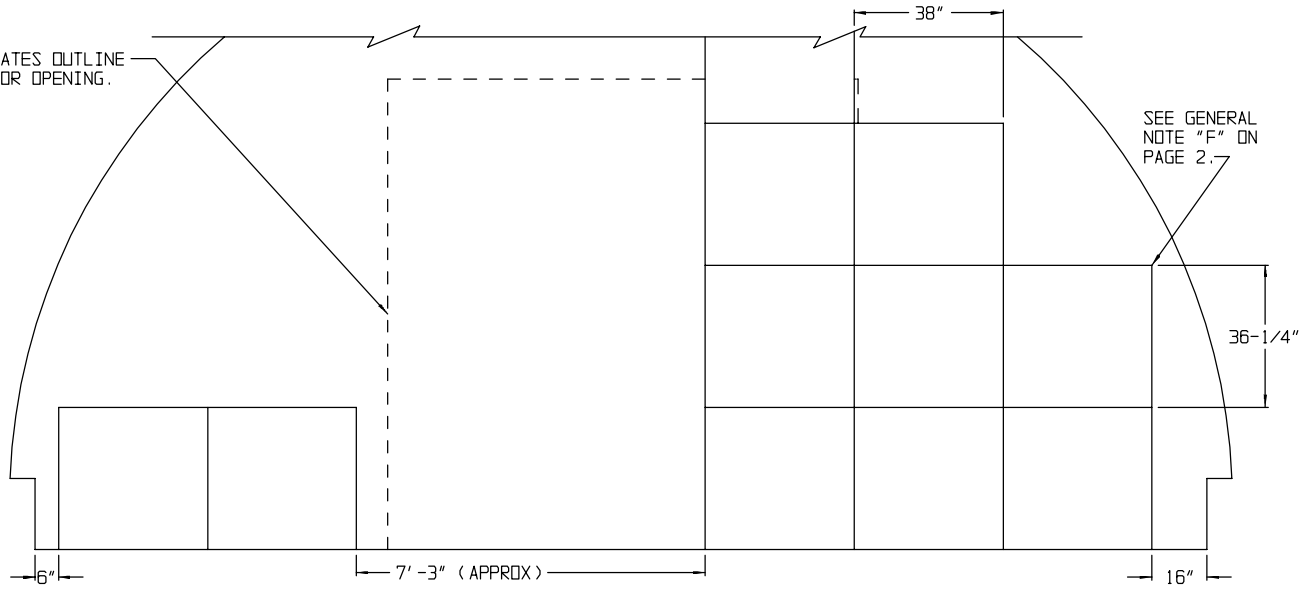

**SECTION 0-0**

("C" STACK, 11 PALLET UNITS)



STORAGE IN 89'-0" MAGAZINE

ITEM (13'-6" HIGH) QUANTITY \*

PALLET UNITS - - - - - 434

\* CAUTION: SEE GENERAL NOTE "E"  
ON PAGE 2.

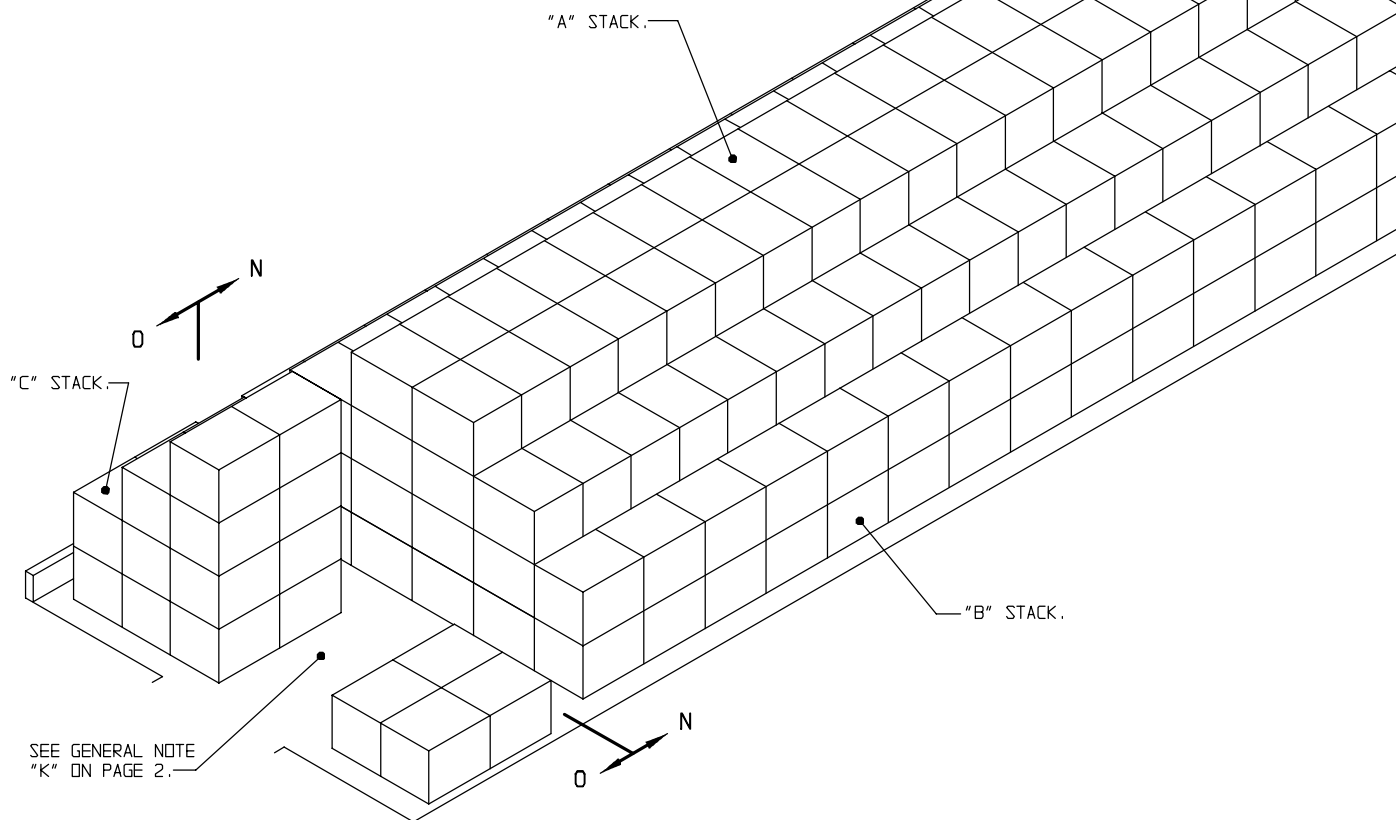

ISOMETRIC VIEW

(89'-0" MAGAZINE)

FOR "GENERAL NOTES", SEE PAGE 2.

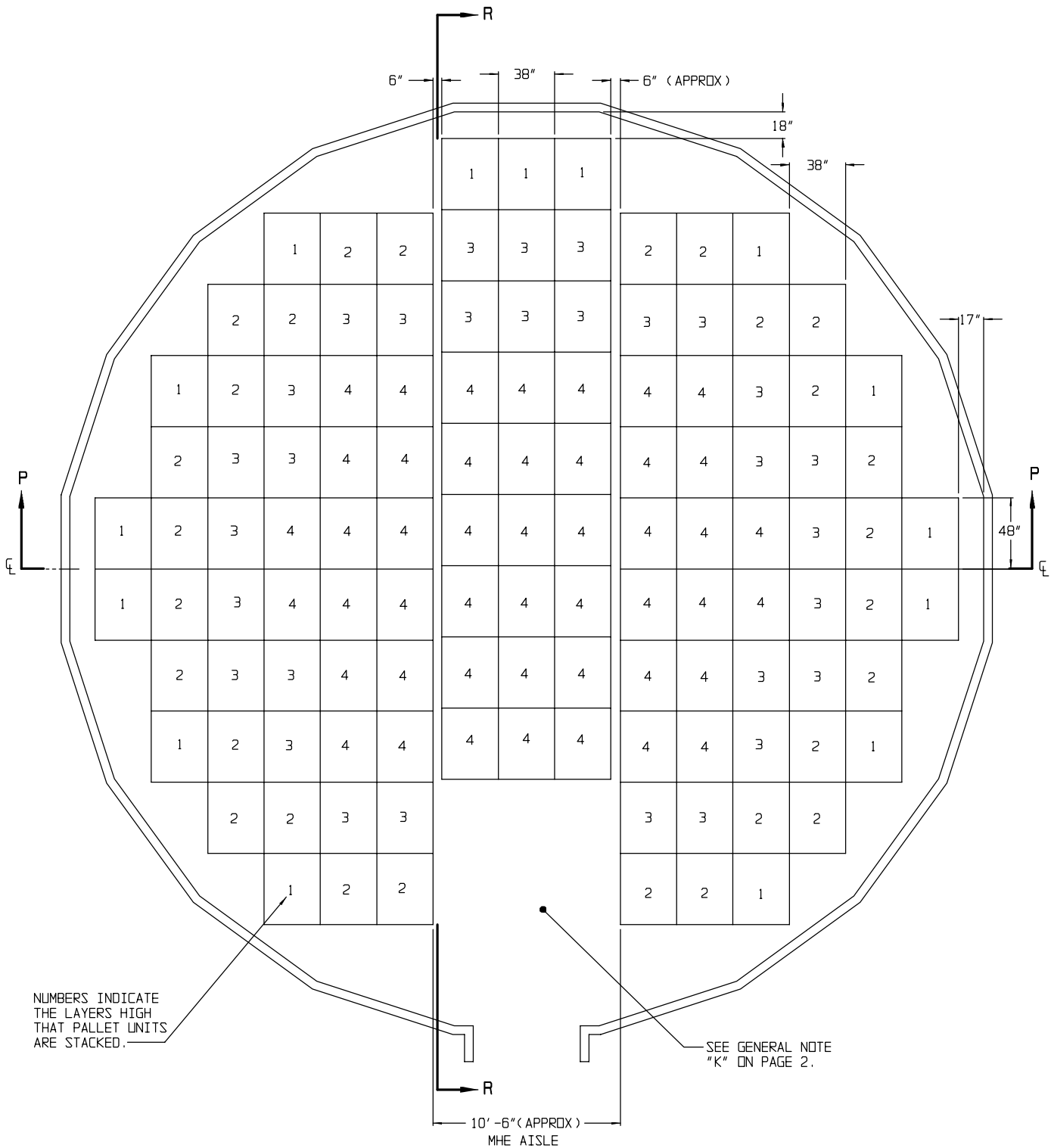

**PLAN VIEW**  
(52'-0" DIA MAGAZINE)

**STORAGE PROCEDURES IN 52'-0" DIA CORBETTA MAGAZINE**

**STORAGE IN 52'-0" DIA MAGAZINE**

ITEM	QUANTITY *
PALLET UNITS - - - - -	345

\* CAUTION: SEE GENERAL NOTE "E" ON PAGE 2.

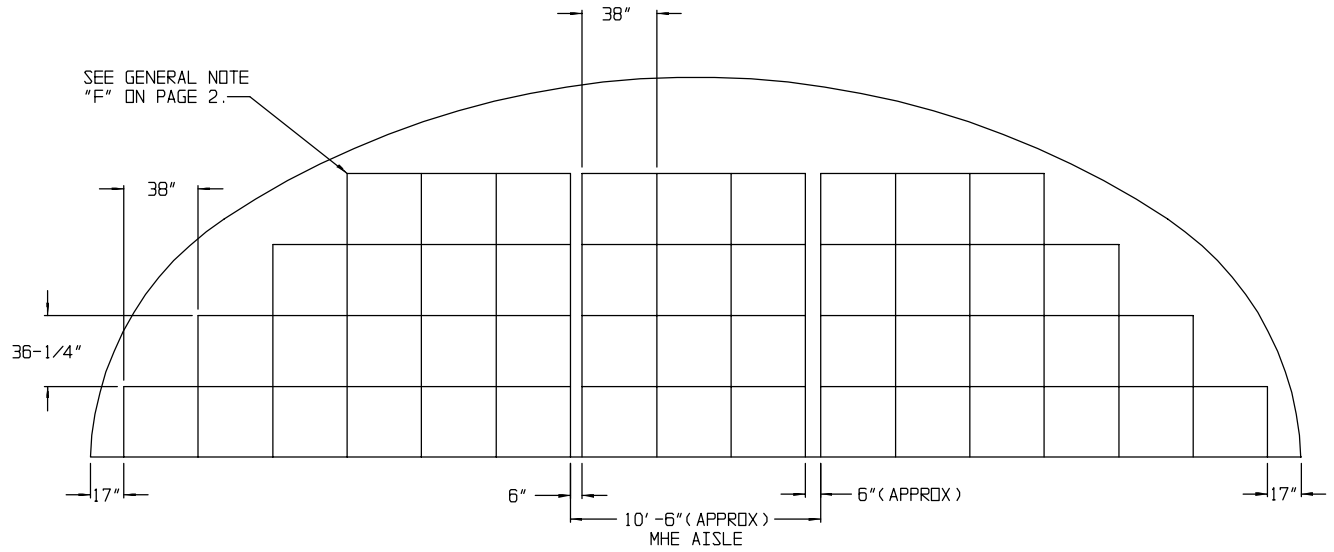

**SECTION P-P**

ONLY ONE OF THE ROWS OF PALLET UNITS IS SHOWN IN THIS SECTION. UNITS LOCATED IN ADJACENT ROWS OR STACKS HAVE NOT BEEN SHOWN FOR CLARITY PURPOSES.

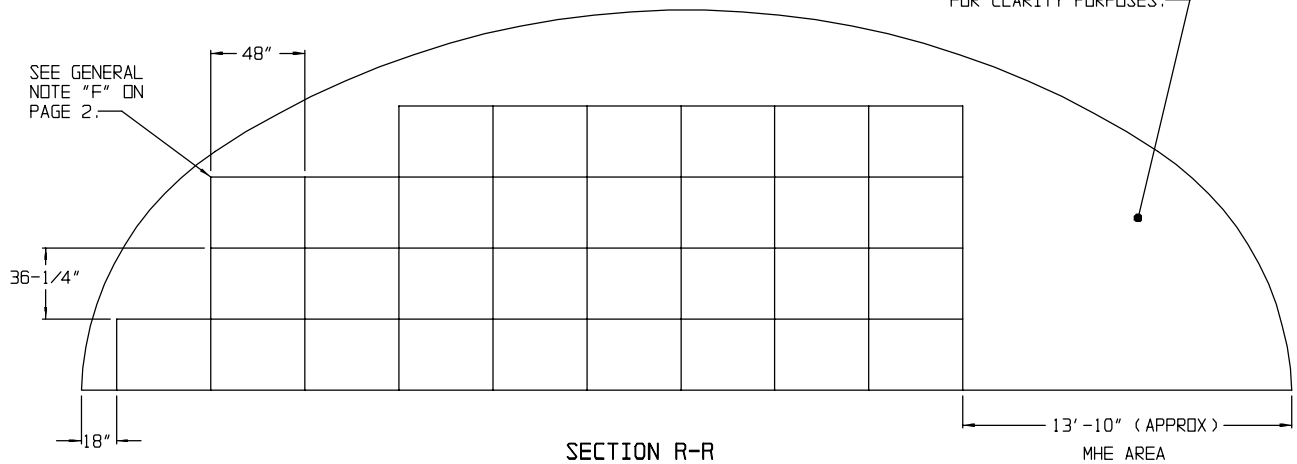

**SECTION R-R**

FOR "GENERAL NOTES", SEE PAGE 2.

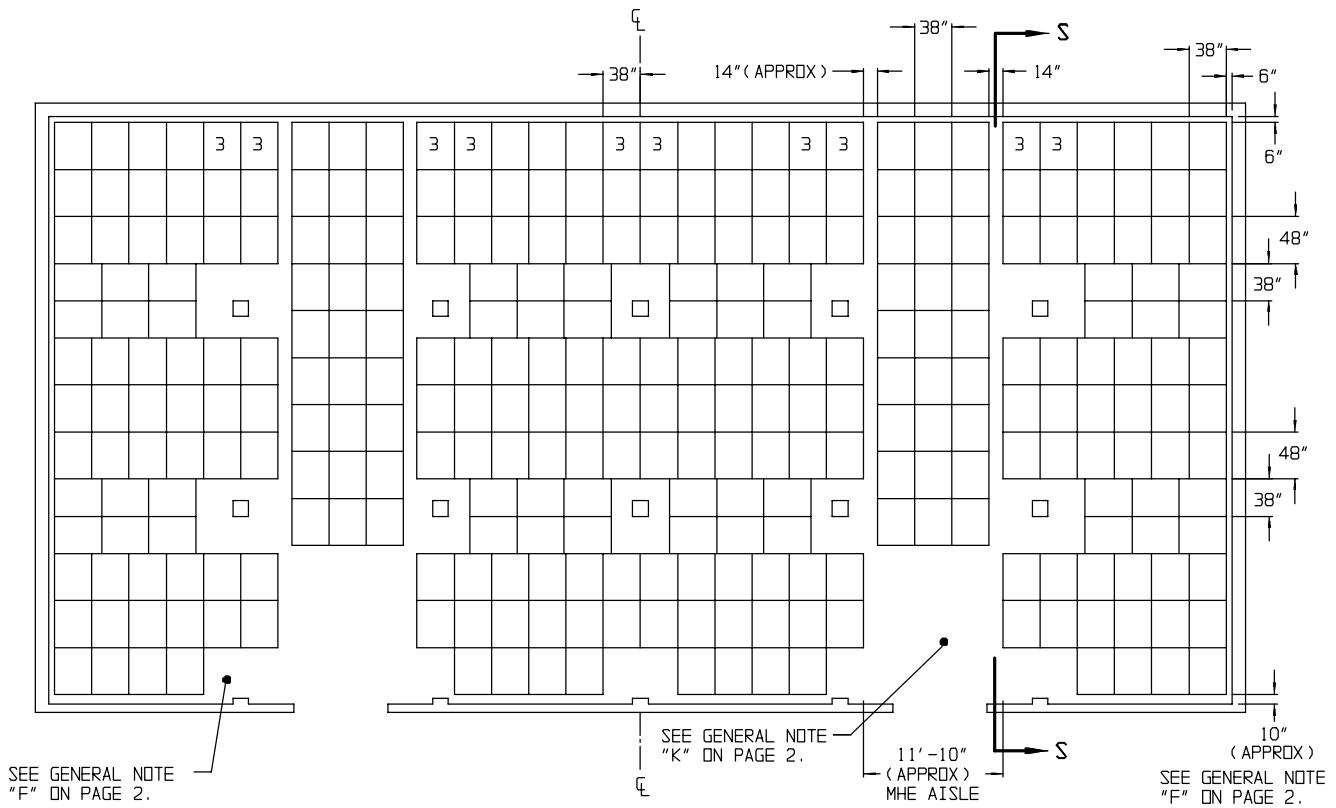

**PLAN VIEW**

(100'-8" X 50'-0" MAGAZINE)

NOTE: ALL STACKS ARE 4 LAYERS HIGH EXCEPT AS INDICATED BY NUMBERS.

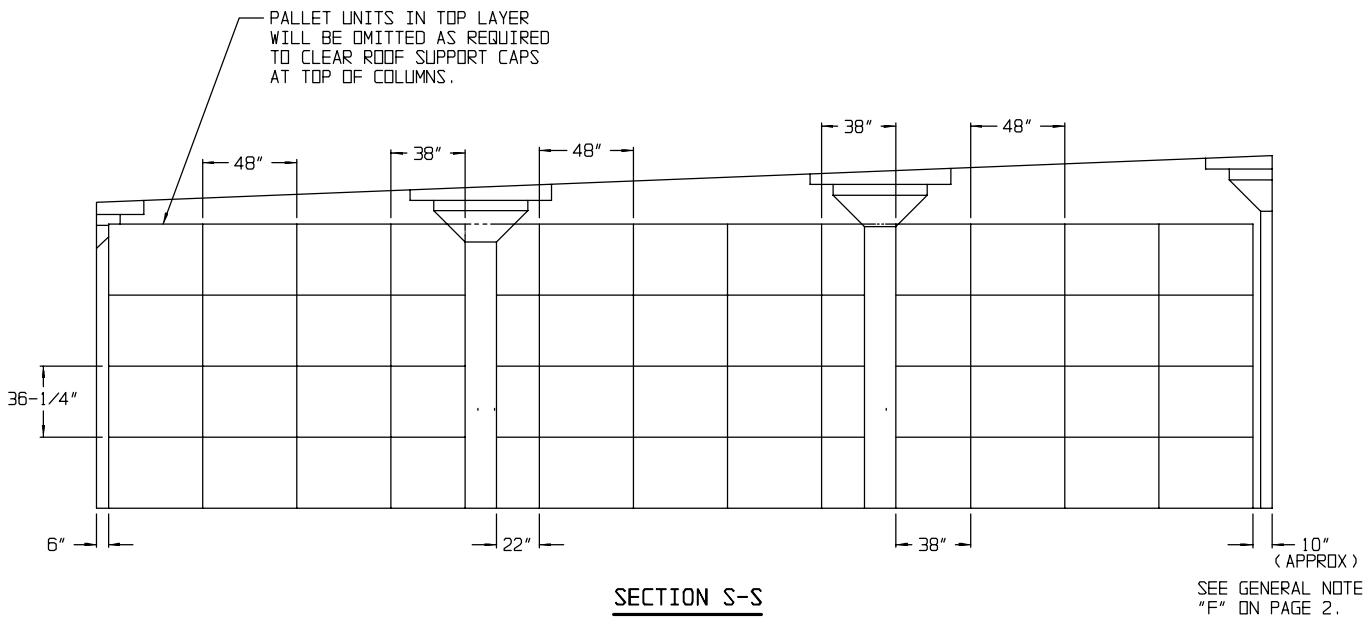

**SECTION S-S**

STORAGE PROCEDURES IN 100'-8" L X 50'-0" W RECTANGULAR MAGAZINE

STORAGE IN 100'-8" X 50'-0" MAGAZINE

ITEM                      QUANTITY \*

PALLET UNITS - - - - - 1,230

\*CAUTION: SEE GENERAL NOTE "E" ON PAGE 2.

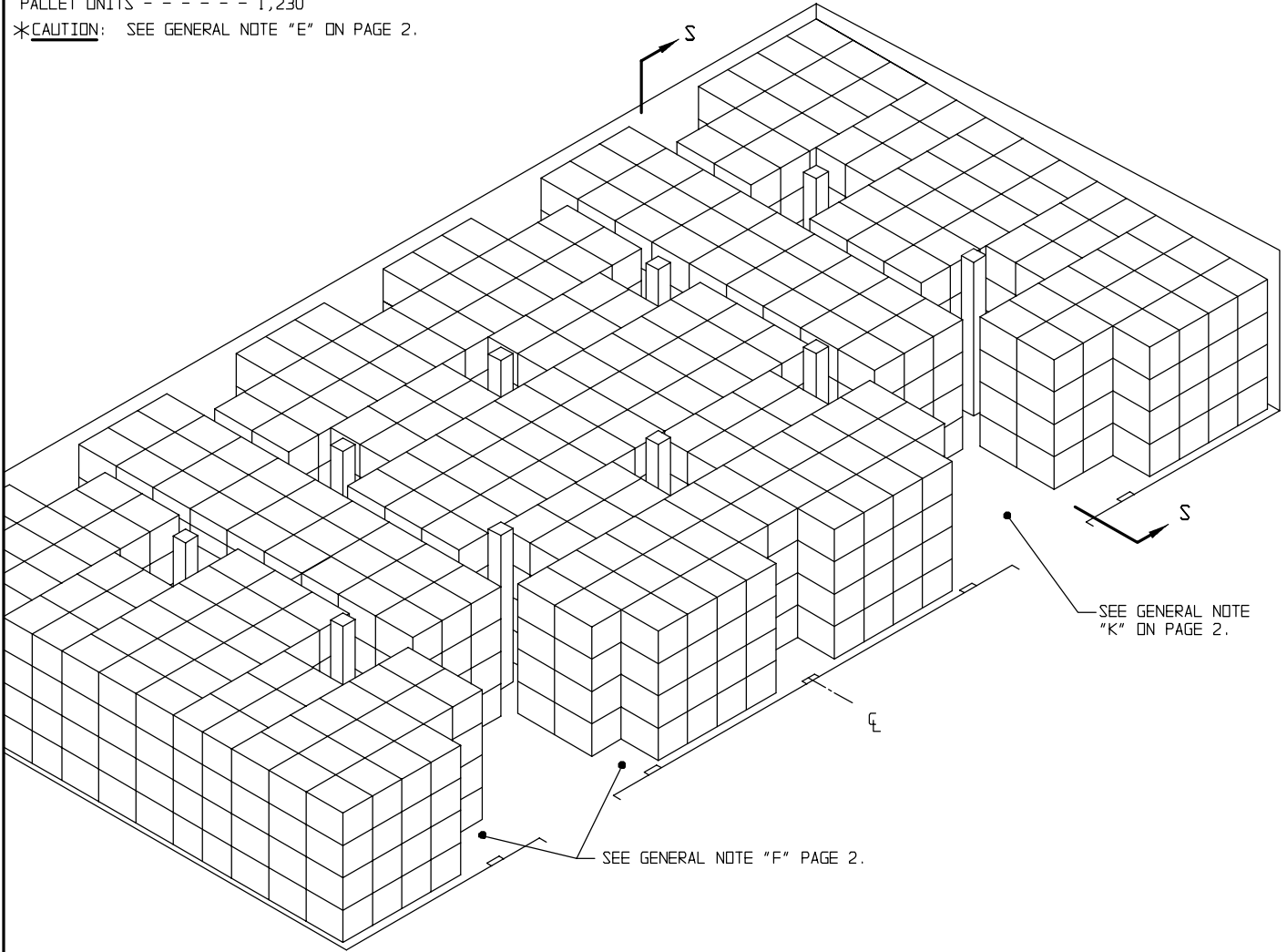

ISOMETRIC VIEW  
(100'-8" X 50'-0" MAGAZINE)

FOR "GENERAL NOTES", SEE PAGE 2.

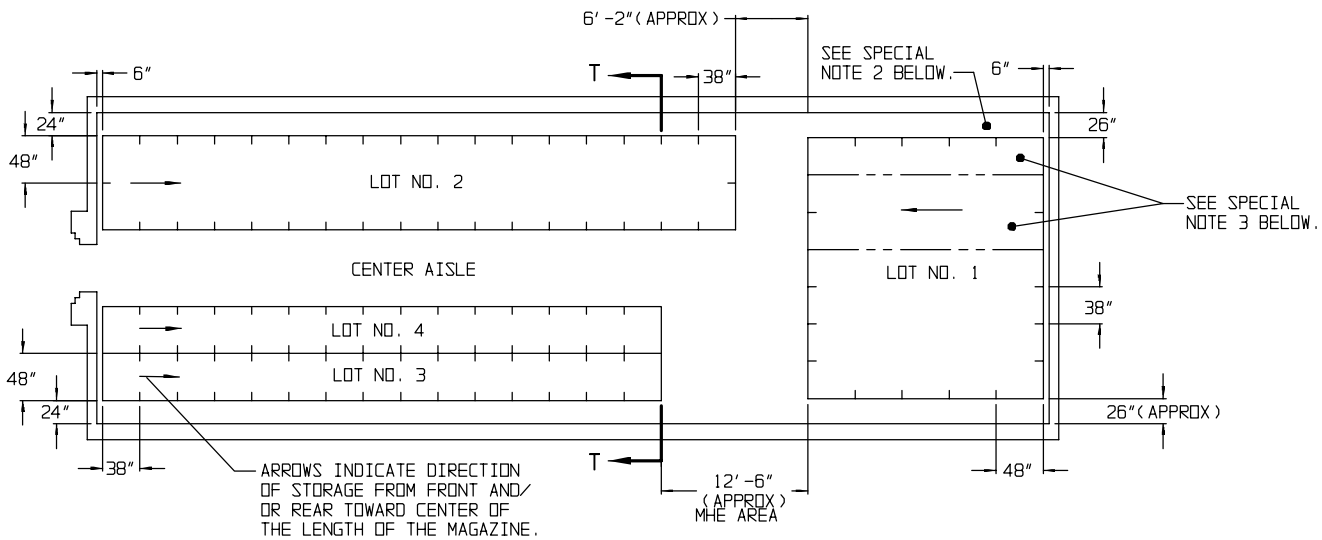

**PLAN VIEW**  
(81'-0" IGLOO SHOWN)

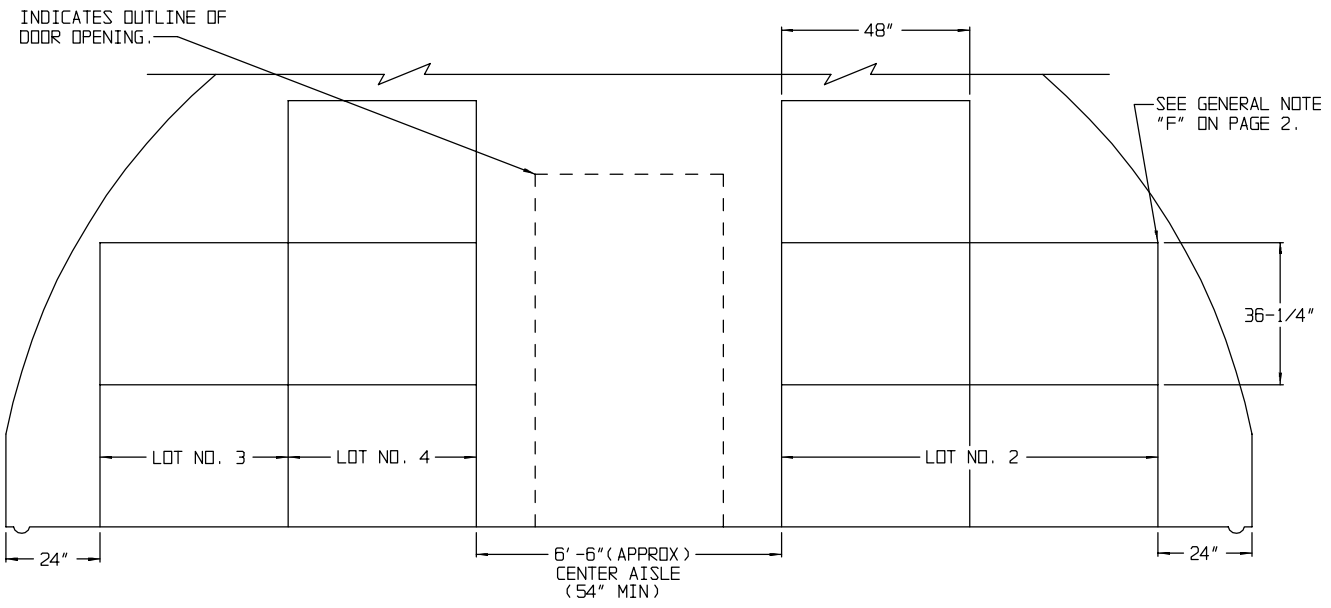

**SECTION T-T**

**SPECIAL NOTES:**

1. THE STORAGE PLANS AND CONFIGURATIONS SHOWN ON THIS PAGE ARE TYPICAL ONLY, AND APPLY TO RELATIVELY LARGE LOTS. ADAPTATIONS MAY BE MADE AS NUMBER AND SIZES OF LOTS TO BE STORED IN MAGAZINE REQUIRE.
2. AN INSPECTION/INVENTORY AISLE MUST BE PROVIDED AT ONE SIDE OR END OF EACH LOT.
3. GENERALLY, THE LARGEST LOT SHOULD BE STORED IN THE REAR OF THE MAGAZINE. HOWEVER, THE REAR AREA MAY BE USED TO STORE MORE THAN ONE LOT BY ERECTING ROWS SIMILAR TO THOSE SHOWN IN THE FRONTAL AREA. A CENTER AISLE WILL NOT BE REQUIRED IN THE REAR AREA AS LONG AS EACH LOT IS ACCESSIBLE FOR REMOVAL AND INSPECTION/INVENTORY IN ACCORDANCE WITH OTHER CRITERIA SPECIFIED IN THESE SPECIAL NOTES AND IN THE GENERAL NOTES ON PAGE 2.
4. EACH LOT WITHIN THE MAGAZINE MUST BE ACCESSIBLE FOR MOVEMENT BY MHE. A SINGLE-LOT OF PALLET UNITS IS CONSIDERED "ACCESSIBLE" IF NO MORE THAN TWELVE (12) "LIFTS" OF ANOTHER LOT OR LOTS HAVE TO BE MADE TO GAIN ACCESS TO THAT LOT. A "LIFT" MAY CONSIST OF ONE (1) OR MORE PALLET UNITS, PROVIDING THE CAPACITY OF THE MHE PERMITS, AND SAFE HANDLING IS NOT JEOPARDIZED.

(CONTINUED AT RIGHT)

**(SPECIAL NOTES CONTINUED)**

5. FOR STORAGE OF MULTIPLE-LOTS, THE DISTANCE FROM THE SIDEWALLS WILL BE BASED ON THE OVERHEAD CLEARANCE REQUIRED FOR MHE.
6. WHEN TWO LOTS ARE STORED ADJACENT TO EACH OTHER, THEY SHOULD BE SEPARATED BY AT LEAST 1" TO PROVIDE CLEARANCE FOR REMOVAL OF EITHER LOT.

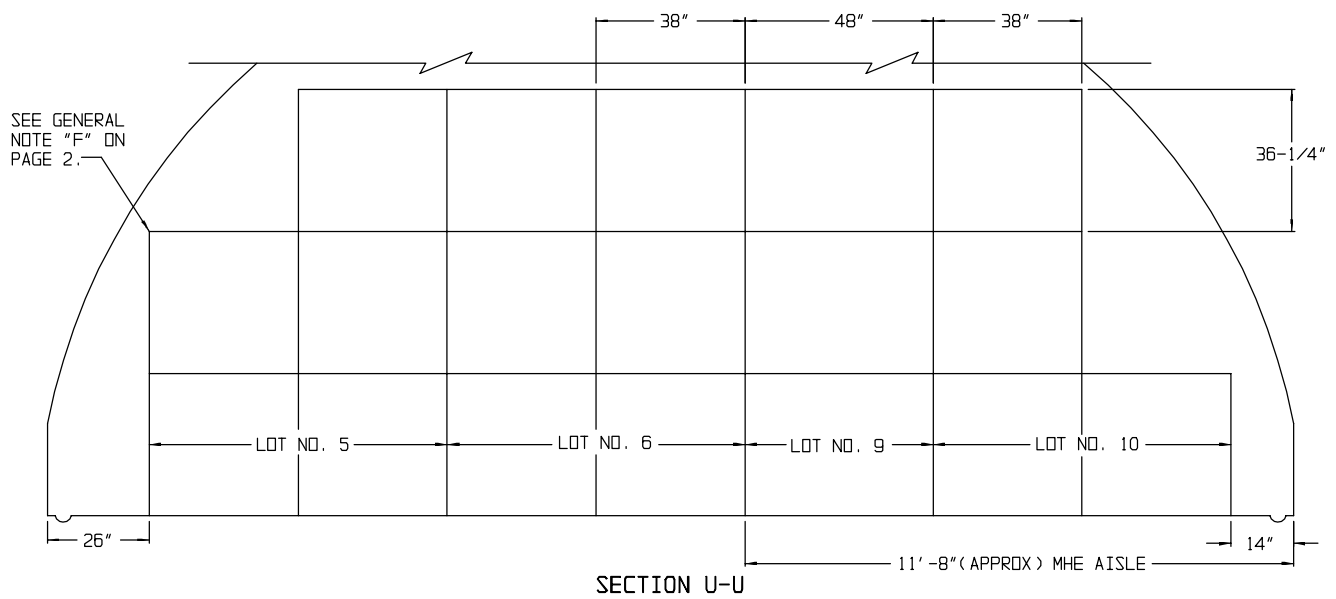
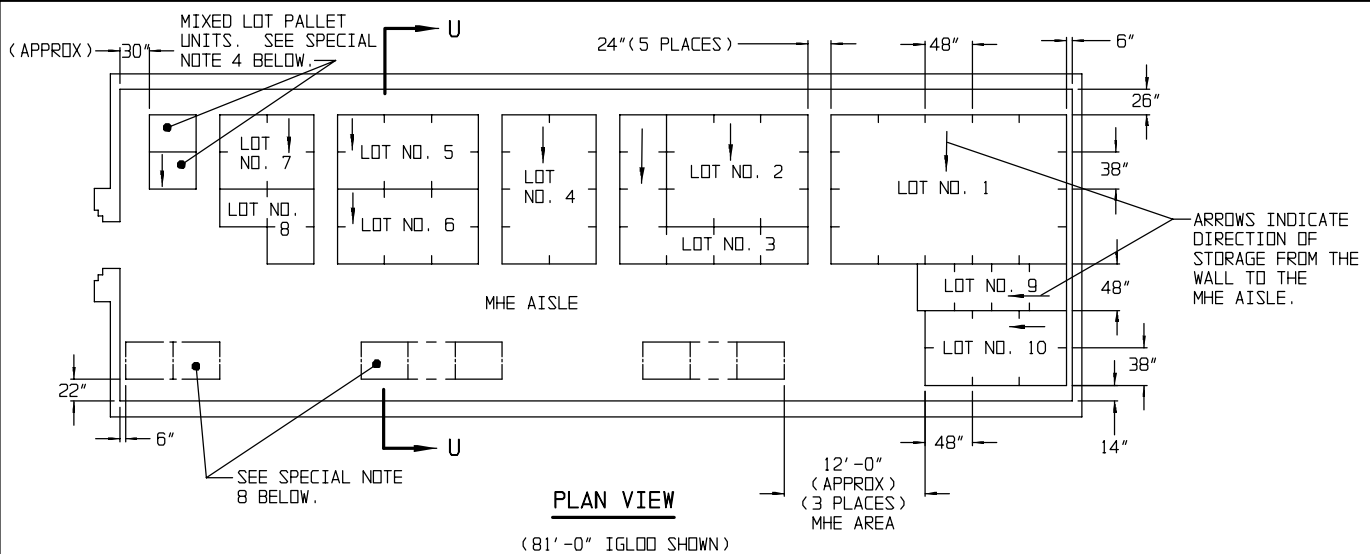

**SPECIAL NOTES:**

1. THE STORAGE PLANS AND CONFIGURATIONS SHOWN ON THIS PAGE ARE TYPICAL ONLY, AND APPLY TO STORAGE OF NUMEROUS SMALL LOTS. ADAPTATIONS MAY BE MADE AS NUMBER AND SIZES OF LOTS TO BE STORED IN MAGAZINE REQUIRE.
2. AN INSPECTION/INVENTORY AISLE NOT LESS THAN 18" WIDE MUST BE PROVIDED AT ONE SIDE OF EACH "BURIED" LOT.
3. GENERALLY, THE LARGEST LOT SHOULD BE STORED IN THE REAR OF THE MAGAZINE. HOWEVER, THE REAR AREA MAY BE USED TO STORE MORE THAN ONE LOT BY ERECTING STACKS SIMILAR TO THOSE SHOWN IN THE FRONTAL AREA. AN MHE AISLE WILL BE REQUIRED ON ONE SIDE OF THE MAGAZINE, AND EACH LOT MUST BE ACCESSIBLE FOR REMOVAL AND INSPECTION/INVENTORY IN ACCORDANCE WITH OTHER CRITERIA SPECIFIED IN THESE SPECIAL NOTES AND IN THE GENERAL NOTES ON PAGE 2.
4. A MIXED-LOT PALLET UNIT MAY HAVE FROM TWO LOTS PER PALLET UNIT UPWARDS TO AS MANY DIFFERENT LOTS AS CONTAINERS WITHIN THAT UNIT. HOWEVER, ALL CONTAINERS AND LOTS WITHIN THE PALLET UNIT MUST HAVE THE SAME NATIONAL STOCK NUMBER AND CONDITION CODE.
5. EACH LOT WITHIN THE MAGAZINE MUST BE ACCESSIBLE FOR MOVEMENT BY MHE. PALLET UNITS OF A SINGLE-LOT OR MIXED-LOT PALLET UNITS ARE CONSIDERED "ACCESSIBLE" IF NOT MORE THAN TWELVE (12) "LIFTS" OF ANOTHER LOT OR LOTS HAVE TO BE MADE TO GAIN ACCESS TO THE SINGLE-LOT OR MIXED-LOT UNITS. A "LIFT" MAY CONSIST OF ONE (1) OR MORE PALLET UNITS, PROVIDING THE CAPACITY OF THE MHE PERMITS AND SAFE HANDLING IS NOT JEOPARDIZED.

(CONTINUED AT RIGHT)

(SPECIAL NOTES CONTINUED)

6. FOR STORAGE OF MULTIPLE LOTS, THE DISTANCE FROM THE SIDEWALL WILL BE BASED ON THE OVERHEAD CLEARANCE REQUIRED FOR MHE.
7. WHEN TWO LOTS ARE STORED ADJACENT TO EACH OTHER, THEY SHOULD BE SEPARATED BY AT LEAST 1" TO PROVIDE CLEARANCE FOR REMOVAL OF EITHER LOT.
8. AREAS ENCLOSED BY DOTTED LINES INDICATE LOCATIONS WHERE ADDITIONAL LOTS MAY BE STORED OR WHERE ADDITIONAL ITEMS MAY BE STORED, THAT ARE FROM THE LOT OR LOTS WHICH ARE DIRECTLY OR ALMOST DIRECTLY ACROSS THE CENTER AISLE ON THE OTHER SIDE OF THE MAGAZINE. COMPLIANCE WITH ALL OF THE MULTIPLE-LOT CRITERIA, AS SET FORTH ON THIS PAGE, MUST BE OBSERVED. THE SIZE OF THE LOTS BEING STORED AND THE CRITERIA OF SPECIAL NOTE 5, RELATIVE TO "12 LIFTS", WILL BE MAJOR FACTORS IMPACTING ON THE NUMBER OF PALLET UNITS THAT CAN BE STORED IN AN "ADDITIONAL STORAGE LOCATION". MORE OR FEWER UNITS THAN SHOWN MAY BE STORED AT ANY ONE OF THE ADDITIONAL STORAGE LOCATIONS. A 12'-0" MHE OPERATING AREA HAS BEEN SPECIFIED FOR ACCESS TO EACH "ADDITIONAL LOCATION" BY FORKLIFT TRUCK. THIS OPERATING AREA IS BASED ON REQUIREMENTS OF FORKLIFT TRUCKS COMMONLY USED IN STORAGE MAGAZINES. THE MHE OPERATING AREA CAN BE ENLARGED AS REQUIRED TO SUIT AVAILABLE FORKLIFT TRUCKS, AND SHOULD BE MADE SMALLER IF AVAILABLE MHE PERMITS. A "CENTER AISLE" (SPACE BETWEEN STORAGE ON ONE SIDE OF A MAGAZINE AND AN "ADDITIONAL STORAGE LOCATION") IS TO BE AT LEAST 54 INCHES WIDE. AN AISLE SLIGHTLY WIDER THAN 54 INCHES WILL ENHANCE FORKLIFT TRUCK MOVEMENT WITHIN A MAGAZINE. HOWEVER, THIS AISLE SHOULD NOT BE MADE WIDER IF A LOSS IN STORAGE RESULTS.

**TYPICAL MULTIPLE-LOT STORAGE IN IGL00 AND ARCH TYPE MAGAZINES**

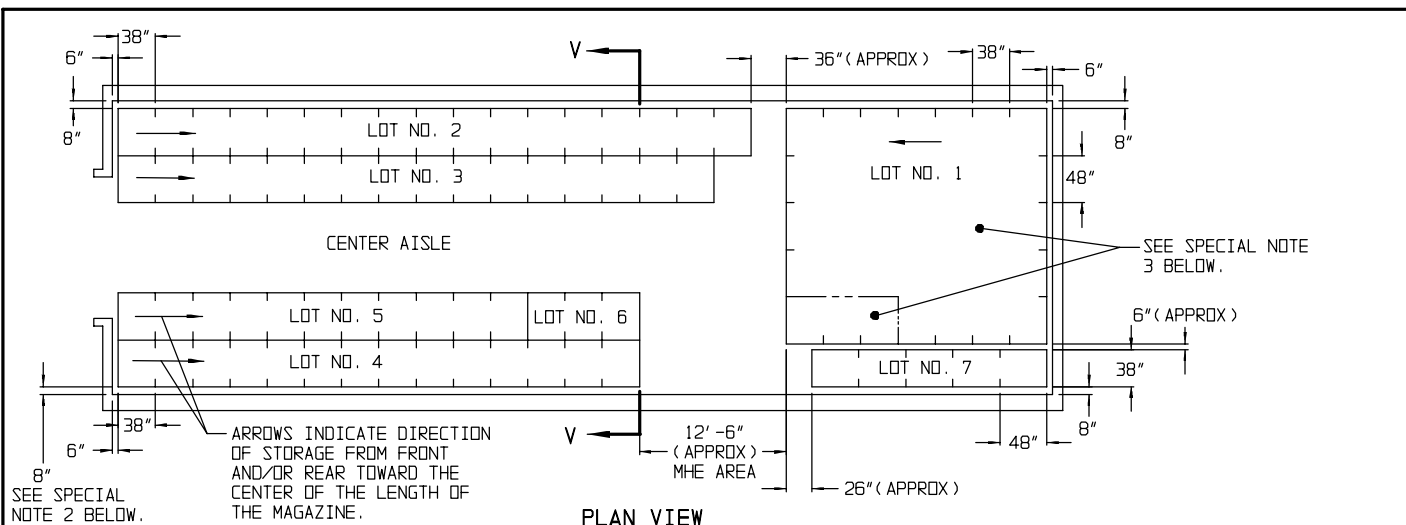

**PLAN VIEW**

(80'-0" MAGAZINE SHOWN)

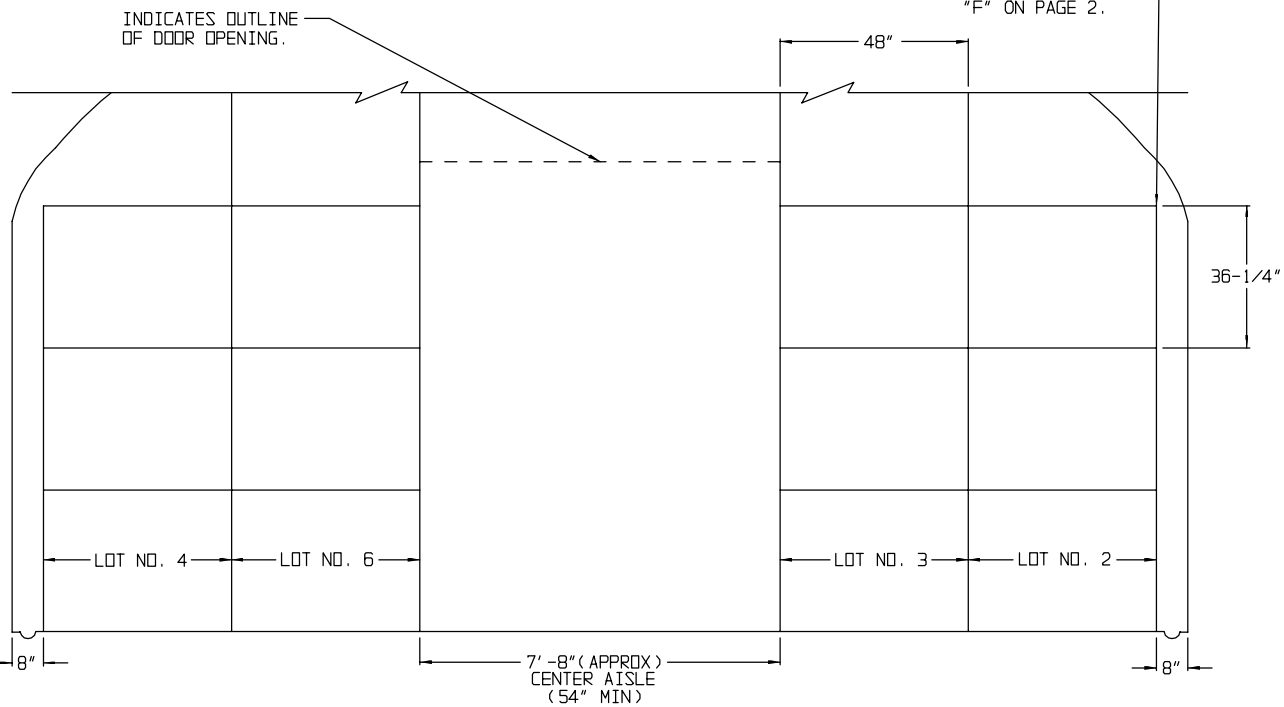

**SECTION V-V**

**SPECIAL NOTES:**

1. THE STORAGE PLANS AND CONFIGURATIONS SHOWN ON THIS PAGE ARE TYPICAL ONLY, AND APPLY TO RELATIVELY LARGE LOTS. ADAPTATIONS MAY BE MADE AS NUMBER AND SIZES OF LOTS TO BE STORED IN MAGAZINE REQUIRE.
2. AN INSPECTION/INVENTORY AISLE MUST BE PROVIDED AT ONE SIDE OR END OF EACH LOT.
3. GENERALLY, THE LARGEST LOT SHOULD BE STORED IN THE REAR OF THE MAGAZINE. HOWEVER, THE REAR AREA MAY BE USED TO STORE MORE THAN ONE LOT BY ERECTING ROWS SIMILAR TO THOSE SHOWN IN THE FRONTAL AREA. A CENTER AISLE WILL NOT BE REQUIRED IN THE REAR AREA AS LONG AS EACH LOT IS ACCESSIBLE FOR REMOVAL AND INSPECTION/INVENTORY IN ACCORDANCE WITH OTHER CRITERIA SPECIFIED IN THESE SPECIAL NOTES AND IN THE GENERAL NOTES ON PAGE 2.
4. EACH LOT WITHIN THE MAGAZINE MUST BE ACCESSIBLE FOR MOVEMENT BY MHE. A SINGLE-LOT OF PALLET UNITS IS CONSIDERED "ACCESSIBLE" IF NOT MORE THAN TWELVE (12) "LIFTS" OF ANOTHER LOT OR LOTS HAVE TO BE MADE TO GAIN ACCESS TO THAT LOT. A "LIFT" MAY CONSIST OF ONE (1) OR MORE PALLET UNITS, PROVIDING THE CAPACITY OF THE MHE PERMITS, AND SAFE HANDLING IS NOT JEOPARDIZED

(CONTINUED AT RIGHT)

**(SPECIAL NOTES CONTINUED)**

5. FOR STORAGE OF MULTIPLE LOTS, THE DISTANCE FROM THE SIDEWALL WILL BE BASED ON THE OVERHEAD CLEARANCE REQUIRED FOR MHE.
6. WHEN TWO LOTS ARE STORED ADJACENT TO EACH OTHER, THEY SHOULD BE SEPARATED BY AT LEAST 1" TO PROVIDE CLEARANCE FOR REMOVAL OF EITHER LOT.



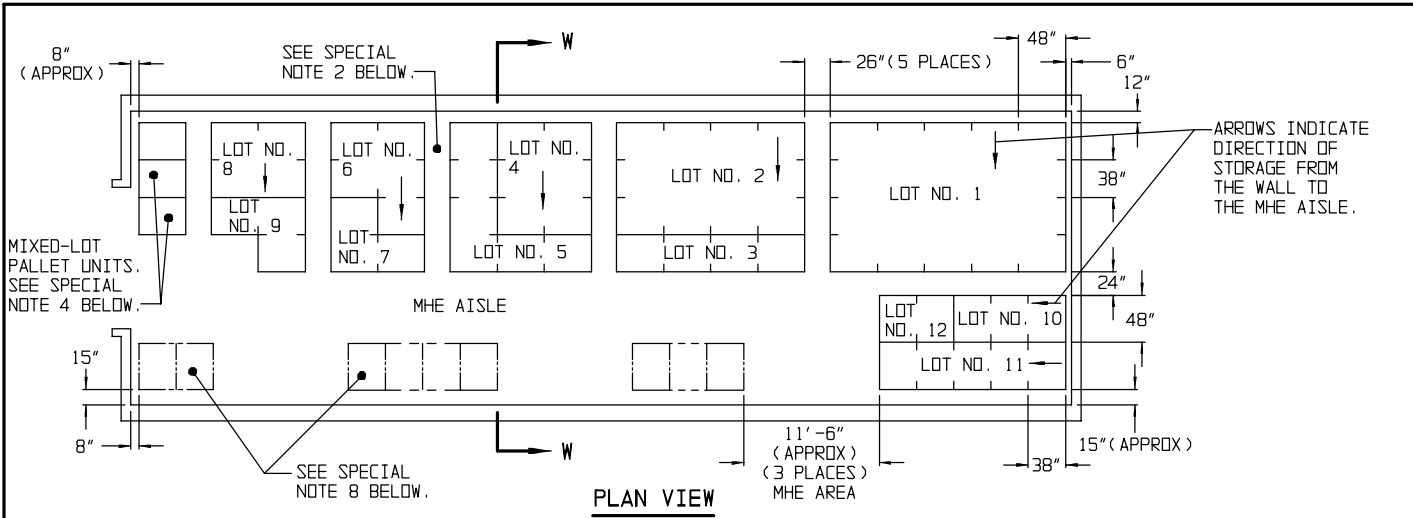

PLAN VIEW

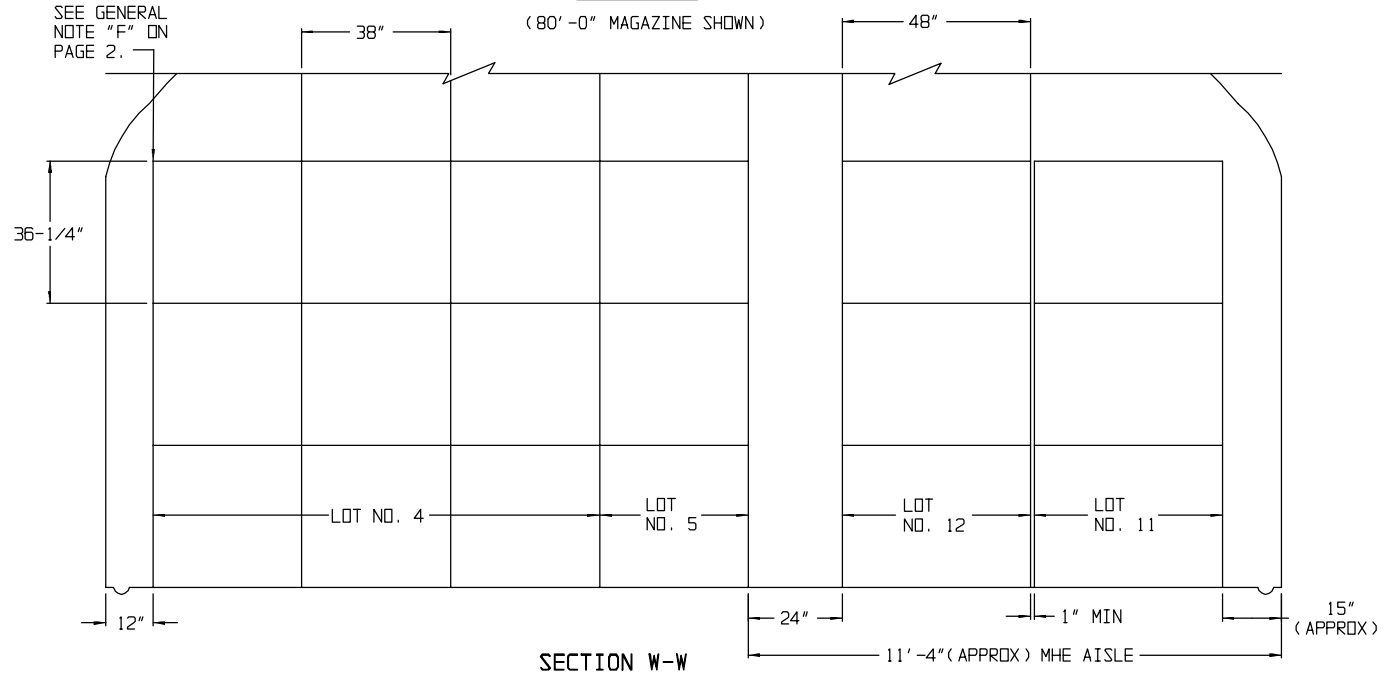

SECTION W-W

SPECIAL NOTES:

(SPECIAL NOTES CONTINUED)

1. THE STORAGE PLANS AND CONFIGURATIONS SHOWN ON THIS PAGE ARE TYPICAL ONLY, AND APPLY TO STORAGE OF NUMEROUS SMALL LOTS. ADAPTATIONS MAY BE MADE AS NUMBER AND SIZES OF LOTS TO BE STORED IN MAGAZINE REQUIRE.
2. AN INSPECTION/INVENTORY AISLE NOT LESS THAN 18" WIDE MUST BE PROVIDED AT ONE SIDE OF EACH "BURIED" LOT.
3. GENERALLY, THE LARGEST LOT SHOULD BE STORED IN THE REAR OF THE MAGAZINE. HOWEVER, THE REAR AREA MAY BE USED TO STORE MORE THAN ONE LOT BY ERECTING STACKS SIMILAR TO THOSE SHOWN IN THE FRONTAL AREA. AN MHE AISLE WILL BE REQUIRED ON ONE SIDE OF THE MAGAZINE, AND EACH LOT MUST BE ACCESSIBLE FOR REMOVAL AND INSPECTION/INVENTORY IN ACCORDANCE WITH OTHER CRITERIA SPECIFIED IN THESE SPECIAL NOTES AND IN THE GENERAL NOTES ON PAGE 2.
4. A MIXED-LOT PALLET UNIT MAY HAVE FROM TWO LOTS PER PALLET UNIT UPWARDS TO AS MANY DIFFERENT LOTS AS CONTAINERS WITHIN THAT UNIT. HOWEVER, ALL CONTAINERS AND LOTS WITHIN THE PALLET UNIT MUST HAVE THE SAME NATIONAL STOCK NUMBER AND CONDITION CODE.
5. EACH LOT WITHIN THE MAGAZINE MUST BE ACCESSIBLE FOR MOVEMENT BY MHE. PALLET UNITS OF A SINGLE-LOT OR MIXED-LOT PALLET UNITS ARE CONSIDERED "ACCESSIBLE" IF NOT MORE THAN TWELVE (12) "LIFTS" OF ANOTHER LOT OR LOTS HAVE TO BE MADE TO GAIN ACCESS TO THE SINGLE-LOT OR MIXED-LOT UNITS. A "LIFT" MAY CONSIST OF ONE (1) OR MORE PALLET UNITS, PROVIDING THE CAPACITY OF THE MHE PERMITS AND SAFE HANDLING IS NOT JEOPARDIZED.
6. FOR STORAGE OF MULTIPLE LOTS, THE DISTANCE FROM THE SIDEWALL WILL BE BASED ON THE OVERHEAD CLEARANCE REQUIRED FOR MHE.
7. WHEN TWO LOTS ARE STORED ADJACENT TO EACH OTHER, THEY SHOULD BE SEPARATED BY AT LEAST 1" TO PROVIDE CLEARANCE FOR REMOVAL OF EITHER LOT.
8. AREAS ENCLOSED BY DOTTED LINES INDICATE LOCATIONS WHERE ADDITIONAL LOTS MAY BE STORED OR WHERE ADDITIONAL ITEMS MAY BE STORED, THAT ARE FROM THE LOT OR LOTS WHICH ARE DIRECTLY OR ALMOST DIRECTLY ACROSS THE CENTER AISLE ON THE OTHER SIDE OF THE MAGAZINE. COMPLIANCE WITH ALL OF THE MULTIPLE-LOT CRITERIA AS SET FORTH ON THIS PAGE MUST BE OBSERVED. THE SIZE OF THE LOTS BEING STORED AND THE CRITERIA OF SPECIAL NOTE 5, RELATIVE TO "12 LIFTS", WILL BE MAJOR FACTORS IMPACTING ON THE NUMBER OF PALLET UNITS THAT CAN BE STORED IN AN "ADDITIONAL STORAGE LOCATION". MORE OR FEWER STACKS THAN SHOWN MAY BE STORED AT ANY ONE OF THE ADDITIONAL STORAGE LOCATIONS. AN 11'-6" MHE OPERATING AREA HAS BEEN SPECIFIED FOR ACCESS TO EACH "ADDITIONAL LOCATION" BY FORKLIFT TRUCK. THIS OPERATING AREA IS BASED ON REQUIREMENTS OF FORKLIFT TRUCKS COMMONLY USED IN STORAGE MAGAZINES. THE MHE OPERATING AREA CAN BE ENLARGED AS REQUIRED TO SUIT AVAILABLE FORKLIFT TRUCKS, AND SHOULD BE MADE SMALLER IF AVAILABLE MHE PERMITS. A "CENTER AISLE" (SPACE BETWEEN STORAGE ON ONE SIDE OF A MAGAZINE AND AN "ADDITIONAL STORAGE LOCATION") IS TO BE AT LEAST 54 INCHES WIDE. AN AISLE SLIGHTLY WIDER THAN 54 INCHES WILL ENHANCE FORKLIFT MOVEMENT WITHIN A MAGAZINE. HOWEVER, THIS AISLE SHOULD NOT BE MADE WIDER IF A LOSS IN STORAGE RESULTS.

(CONTINUED AT RIGHT)

TYPICAL MULTIPLE-LOT STORAGE IN STRADLEY MAGAZINE

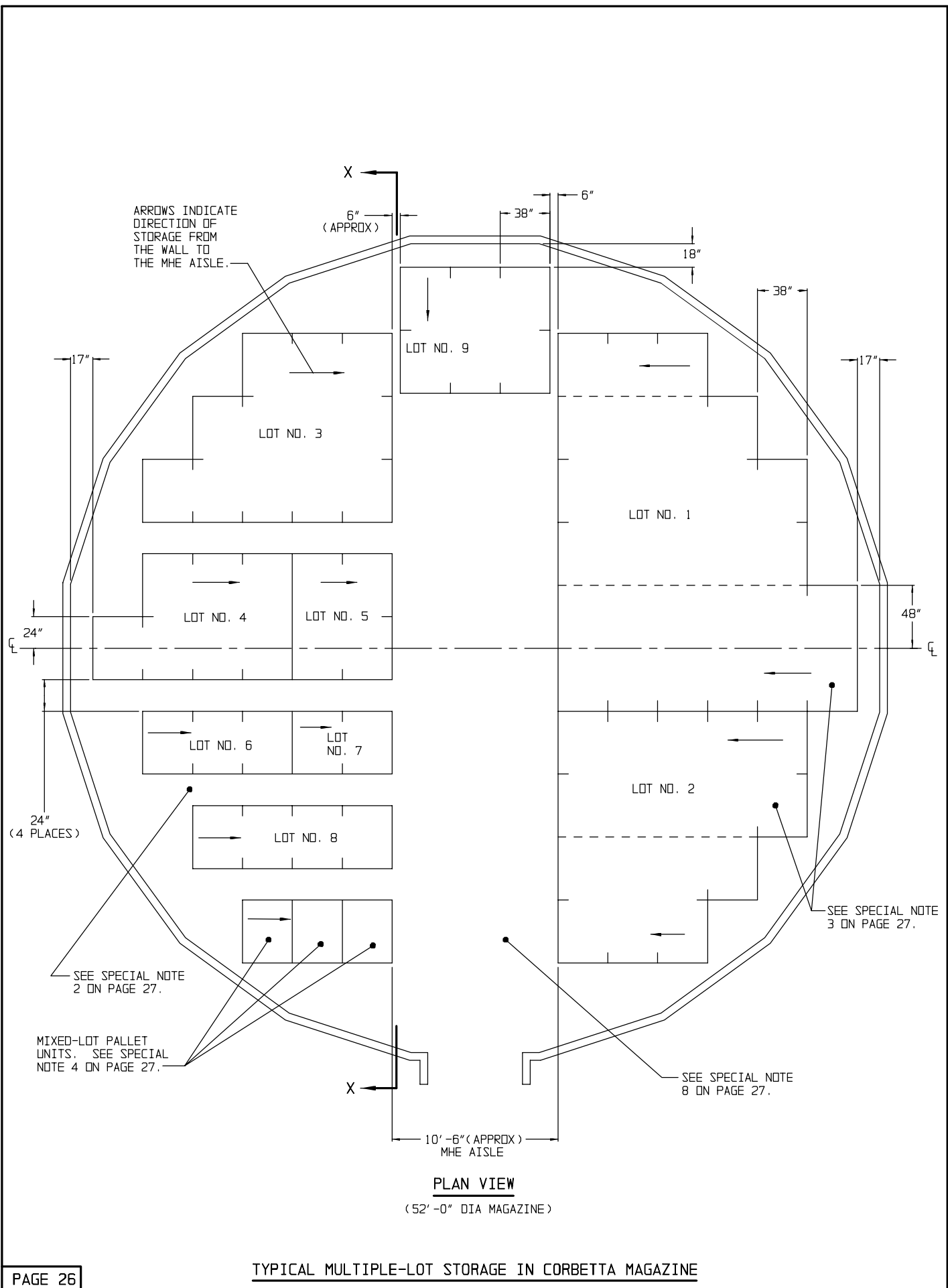

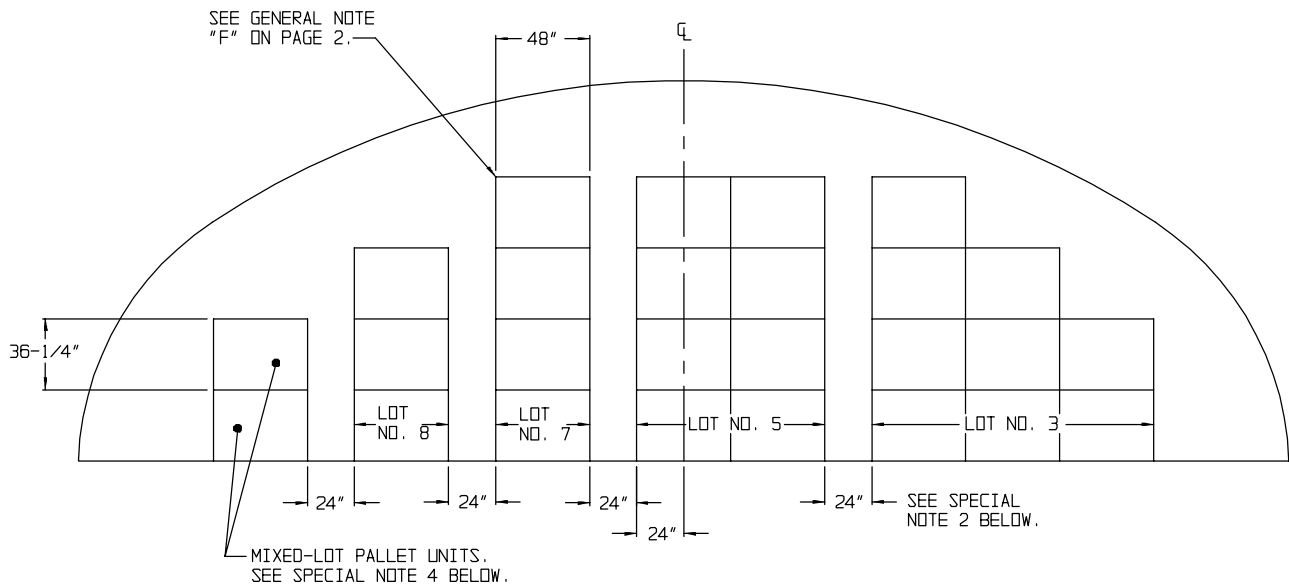

**SECTION X-X**

**SPECIAL NOTES:**

1. THE STORAGE PLANS SHOWN ARE TYPICAL ONLY. ADAPTATIONS MAY BE MADE AS NUMBER AND SIZES OF LOTS TO BE STORED IN MAGAZINE REQUIRE.
2. AN INSPECTION/INVENTORY AISLE NOT LESS THAN 18" WIDE MUST BE PROVIDED AT ONE SIDE OF EACH "BURIED" LOT.
3. GENERALLY, THE LARGEST LOT SHOULD BE STORED ON ONE SIDE OF THE MAGAZINE. HOWEVER, BOTH SIDES MAY BE USED TO STORE MORE THAN ONE LOT BY ERECTING ROWS SIMILAR TO THOSE SHOWN ON THE LEFT SIDE. EACH ADDITIONAL LOT MUST BE ACCESSIBLE FOR REMOVAL AND INSPECTION/INVENTORY IN ACCORDANCE WITH OTHER CRITERIA SPECIFIED IN THESE SPECIAL NOTES AND IN THE GENERAL NOTES ON PAGE 2.
4. A MIXED-LOT PALLET UNIT MAY HAVE FROM TWO LOTS PER PALLET UNIT UPWARDS TO AS MANY DIFFERENT LOTS AS CONTAINERS WITHIN THAT UNIT. HOWEVER, ALL CONTAINERS AND LOTS WITHIN THE PALLET UNIT MUST HAVE THE SAME NATIONAL STOCK NUMBER AND CONDITION CODE.

(CONTINUED AT RIGHT)

**(SPECIAL NOTES CONTINUED)**

5. EACH LOT WITHIN THE MAGAZINE MUST BE ACCESSIBLE FOR MOVEMENT BY MHE. PALLET UNITS OF A SINGLE-LOT OR MIXED-LOT PALLET UNITS ARE CONSIDERED "ACCESSIBLE" IF NO MORE THAN TWELVE (12) "LIFTS" OF ANOTHER LOT OR LOTS HAVE TO BE MADE TO GAIN ACCESS TO THE SINGLE-LOT OR MIXED-LOT UNITS. A "LIFT" MAY CONSIST OF ONE (1) OR MORE PALLET UNITS, PROVIDING THE CAPACITY OF THE MHE PERMITS, AND SAFE HANDLING IS NOT JEDPARDIZED.
6. FOR STORAGE OF MULTIPLE LOTS, THE DISTANCE FROM THE WALL WILL BE BASED ON THE OVERHEAD CLEARANCE REQUIRED FOR MHE.
7. WHEN TWO LOTS ARE STORED ADJACENT TO EACH OTHER THEY SHOULD BE SEPARATED BY AT LEAST 1" TO PROVIDE CLEARANCE FOR REMOVAL OF EITHER LOT.
8. THE MHE AISLE MAY BE USED TO STORE ONE OR MORE STACKS OF ADDITIONAL LOTS OR ADDITIONAL ITEMS THAT ARE FROM A LOT ADJACENT TO THE MHE AISLE. THIS ADDITIONAL STORAGE IS TO BE ARRANGED IN A MANNER SIMILAR TO ARRANGEMENTS DEPICTED ON PAGES 23 AND 25 FOR THE "ADDITIONAL STORAGE LOCATIONS" (SHOWN BY DOTTED LINES). ADEQUATE SPACE FOR MHE OPERATION, AS DESCRIBED ON PAGES 23 AND 25, MUST BE MADE AVAILABLE FOR THE ADDITIONAL STORAGE. ALSO, COMPLIANCE WITH ALL OF THE MULTIPLE-LOT CRITERIA AS SET FORTH ON THIS PAGE MUST BE OBSERVED.

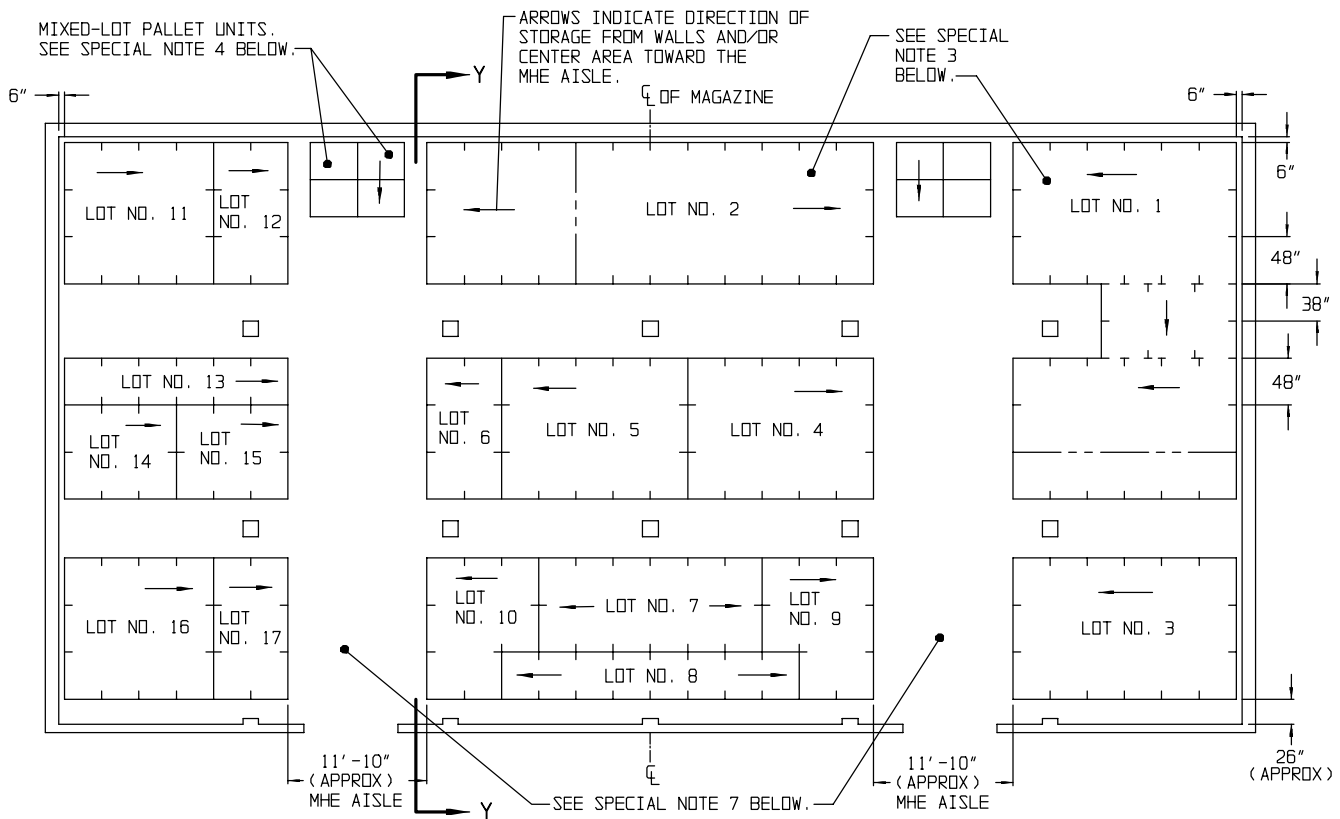

**PLAN VIEW**

(100'-8" X 50'-0" MAGAZINE)

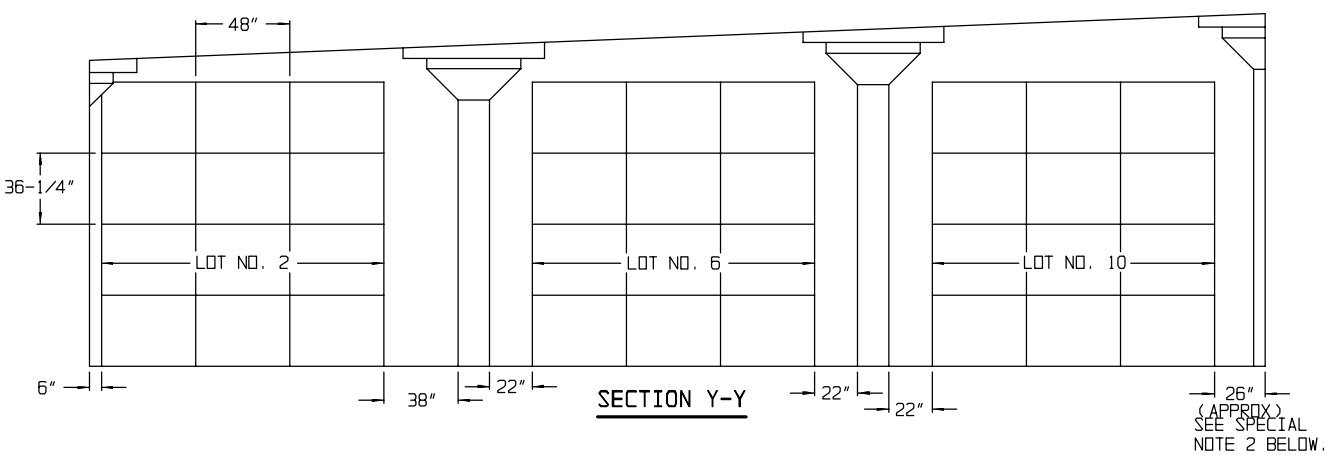

**SECTION Y-Y**

(APPROX)  
SEE SPECIAL NOTE 2 BELOW.

**SPECIAL NOTES:**

1. THE STORAGE PLANS SHOWN ARE TYPICAL ONLY. ADAPTATIONS MAY BE MADE AS NUMBER AND SIZES OF LOTS TO BE STORED IN MAGAZINE REQUIRE.
2. AN INSPECTION/INVENTORY AISLE NOT LESS THAN 18" WIDE MUST BE PROVIDED AT ONE SIDE OF EACH "BURIED" LOT.
3. GENERALLY, THE LARGEST LOT SHOULD BE STORED IN THE REAR OR ON ONE SIDE OF THE MAGAZINE. HOWEVER, THESE AREAS MAY BE USED TO STORE MORE THAN ONE LOT BY ERECTING ROWS SIMILAR TO THOSE SHOWN IN THE CENTER AREA OR AS TYPICALLY INDICATED BY DOTTED LINES. EACH ADDITIONAL LOT MUST BE ACCESSIBLE FOR REMOVAL AND INSPECTION/INVENTORY IN ACCORDANCE WITH OTHER CRITERIA SPECIFIED IN THESE SPECIAL NOTES AND IN THE GENERAL NOTES ON PAGE 2.
4. A MIXED-LOT PALLET UNIT MAY HAVE FROM TWO LOTS PER PALLET UNIT UPWARDS TO AS MANY DIFFERENT LOTS AS CONTAINERS WITHIN THAT UNIT. HOWEVER, ALL CONTAINERS AND LOTS WITHIN THAT UNIT MUST HAVE THE SAME NATIONAL STOCK NUMBER AND CONDITION CODE.

(CONTINUED AT RIGHT)

**(SPECIAL NOTES CONTINUED)**

5. EACH LOT WITHIN THE MAGAZINE MUST BE ACCESSIBLE FOR MOVEMENT BY MHE. PALLET UNITS OF A SINGLE-LOT OR MIXED-LOT PALLET UNITS ARE CONSIDERED "ACCESSIBLE" IF NO MORE THAN TWENTY-FOUR (24) "LIFTS" OF ANOTHER LOT OR LOTS HAVE TO BE MADE TO GAIN ACCESS TO THE SINGLE-LOT OR MIXED-LOT UNITS. A "LIFT" MAY CONSIST OF ONE (1) OR MORE PALLET UNITS PROVIDING THE CAPACITY OF THE MHE PERMITS, AND SAFE HANDLING IS NOT JEOPARDIZED.
6. WHEN TWO LOTS ARE STORED ADJACENT TO EACH OTHER THEY SHOULD BE SEPARATED BY AT LEAST 1" TO PROVIDE CLEARANCE FOR REMOVAL OF EITHER LOT.
7. THE MHE AISLE MAY BE USED TO STORE ONE OR MORE STACKS OF ADDITIONAL LOTS OR ADDITIONAL ITEMS THAT ARE FROM A LOT ADJACENT TO THE MHE AISLE. THIS ADDITIONAL STORAGE IS TO BE ARRANGED IN A MANNER SIMILAR TO ARRANGEMENTS DEPICTED ON PAGES 23 AND 25 FOR THE "ADDITIONAL STORAGE LOCATIONS" (SHOWN BY DOTTED LINES). ADEQUATE SPACE FOR MHE OPERATION, AS DESCRIBED ON PAGES 23 AND 25, MUST BE MADE AVAILABLE FOR THE ADDITIONAL STORAGE. ALSO, COMPLIANCE WITH ALL OF THE MULTIPLE-LOT CRITERIA AS SET FORTH ON THIS PAGE MUST BE OBSERVED.