

STORAGE IN APPROVED MAGAZINES OF ROCKET, 2.75 INCH, WITH WARHEAD, PACKED 3 OR 4 PER WOODEN BOX, UNITIZED 15 BOXES PER 42" X 53" WOODEN PALLET

INDEX

<u>ITEM</u>	<u>PAGE(S)</u>
GENERAL NOTES AND MATERIAL SPECIFICATIONS - - - - -	2
PALLET UNIT DETAIL - - - - -	3
STORAGE PROCEDURES (EARTH COVERED MAGAZINES):	
81'-0", 60'-8" AND 40'-4" L X 26'-6" W X 12'-9" H IGL00 MAGAZINES - - -	4,5
81'-2" L X 26'-6" W X 12'-1-3/4" H ARCH TYPE MAGAZINE - - - - -	6,7
80'-0" AND 40'-0" L X 25'-0" W X 12'-1-3/4" H ARCH TYPE MAGAZINES - - -	8,9
80'-0" AND 40'-0" L X 25'-0" W X 11'-0" H ARCH TYPE MAGAZINES - - - - -	10,11
80'-0" AND 40'-0" L X 25'-0" W X 10'-0" H ARCH TYPE MAGAZINES - - - - -	12,13
80'-0" L X 25'-0" W X 14'-0" H STRADLEY MAGAZINE - - - - -	14,15
89'-0" L X 24'-11" W X 13'-6" H STEEL ARCH MAGAZINE - - - - -	16,17
52'-0" DIA CORBETTA MAGAZINE - - - - -	18,19
100'-8" L X 50'-0" W RECTANGULAR MAGAZINE - - - - -	20,21
TYPICAL MULTIPLE-LOT STORAGE PROCEDURES	
IGL00 AND ARCH TYPE MAGAZINES - - - - -	22,23
STRADLEY MAGAZINE - - - - -	24,25
CORBETTA MAGAZINE - - - - -	26,27
RECTANGULAR MAGAZINE - - - - -	28

U.S. ARMY MATERIEL COMMAND DRAWING			
APPROVED, U.S. ARMY INDUSTRIAL OPERATIONS COMMAND <i>David A. Peterson</i> AMSTA-AR-ESK		DRAFTSMAN	D. WHITMORE
		ENGINEER	M. DAEUMER
APPROVED BY ORDER OF COMMANDING GENERAL, U.S. ARMY MATERIEL COMMAND <i>Larry V. Dulle</i> U.S. ARMY DEFENSE AMMUNITION CENTER AND SCHOOL		SUPPLY ENGINEERING DIVISION	<i>Thomas J. Michale</i>
		LOGISTICS ENGINEERING OFFICE	<i>William J. Ernst</i>
JULY 1996			
CLASS	DIVISION	DRAWING	FILE
19	48	4307	1-3-4-14- 22PA1010

DO NOT SCALE

GENERAL NOTES

(GENERAL NOTES CONTINUED)

- A. THIS DOCUMENT HAS BEEN PREPARED AND ISSUED IN ACCORDANCE WITH AR 740-1 AND AUGMENTS TM 743-200-1 (CHAPTER 5).
- B. THE STORAGE PROCEDURES SPECIFIED HEREIN ARE APPLICABLE TO ROCKET, 2.75 INCH, WITH WARHEAD, PACKED 3 OR 4 PER WOODEN BOX, UNITIZED 15 BOXES PER 42" X 53" WOODEN PALLET. SUBSEQUENT REFERENCE TO PALLET UNIT MEANS THE PALLET UNIT WITH AMMUNITION ITEMS.
- C. FOR DETAIL OF THE PALLET UNIT, REFER TO U.S. ARMY AMC DRAWING 19-48-4116/800-20PA1002, AND TO PAGE 3 OF THIS DRAWING.

PALLET UNIT

DIMENSION - - - 43-7/16" LONG X 72-13/16" WIDE X 34" HIGH.
GROSS WEIGHT - 2,104-2,524 (MAX) POUNDS (APPROX).
CUBE - - - - - 62.2 CUBIC FEET (APPROX).

- D. THE STORAGE PROCEDURES DEPICTED WITHIN THIS DOCUMENT ARE APPLICABLE FOR STORAGE IN VARIOUS TYPES AND SIZES OF MAGAZINES. THE STORAGE PROCEDURES DEPICTED FOR THE SPECIFIC TYPES OF MAGAZINES MAY ALSO BE UTILIZED TO STORE PALLET UNITS IN OTHER TYPES OF APPROVED MAGAZINES. MINOR ADJUSTMENTS MAY BE MADE TO FACILITATE STORAGE IN OTHER TYPES OF MAGAZINES, HOWEVER, THE BASIC PRINCIPLES AS DEPICTED HEREIN WILL BE FOLLOWED.
- E. CAUTION: THE ALLOWABLE "EXPLOSIVE LIMIT" ESTABLISHED FOR A MAGAZINE IS NOT TO BE EXCEEDED. THIS LIMITATION MAY REQUIRE A QUANTITY REDUCTION FROM THE STORAGE AS SHOWN.
- F. STORED PALLET UNITS MUST NOT CONTACT THE WALLS OF A MAGAZINE. TO PROVIDE FOR THIS MANDATORY CLEARANCE REQUIREMENT, UNITS MAY BE ELIMINATED FROM THE DEPICTED STORAGE PATTERN AS NECESSARY.
- G. AISLE DIMENSIONS SHOWN FOR STORAGE PROCEDURES IN MAGAZINES MAY BE ADJUSTED TO SUIT LOCAL CONDITIONS, VARIATIONS IN PALLET UNIT DIMENSIONS, AND/OR AVAILABLE MATERIALS HANDLING EQUIPMENT.
- H. THE MAXIMUM FLOOR LOAD FOR A MAGAZINE AS PRESCRIBED BY LOCAL STANDARDS WILL NOT BE EXCEEDED.
- J. IF AVAILABLE MHE PERMITS, ADDITIONAL PALLETIZED UNITS MAY BE STORED WITHIN THE MHE AREA AND/OR OTHER AVAILABLE AREA OF THE MAGAZINE.
- K. IF THE QUANTITY OF PALLET UNITS FOR A MAGAZINE IS TO BE REDUCED FROM WHAT IS SHOWN HEREIN DUE TO THE PERMITTED "EXPLOSIVE LIMIT" OR FOR ANY OTHER REASON, SUCH AS A LIMITED QUANTITY TO BE STORED, THE DELINEATED PROCEDURES ARE TO BE ADJUSTED BY OMITTING STACKS RATHER THAN BY OMITTING LAYERS.
- L. THE HEIGHT OF THE PACKAGE GUARD ON SOME FORKLIFT TRUCKS MAY NOT PERMIT PLACEMENT OF SOME TOP LAYER UNITS IN THE STACKS SHOWN IN THE STORAGE VIEWS HEREIN, UNLESS TWO UPPER PALLET UNITS ARE HANDLED AS ONE LIFT OR THE PACKAGE GUARD IS REMOVED (TINE CARRIAGE WILL IN MOST INSTANCES PROVIDE ADEQUATE PACKAGE GUARD PROTECTION). ONLY A FORKLIFT TRUCK OF ADEQUATE CAPACITY WILL BE USED WHEN LIFTING TWO PALLET UNITS AS ONE LIFT.
- M. STACK-STABILIZING DUNNAGE IN THE FORM OF "SHIMS" PROBABLY WILL BE REQUIRED TO ACHIEVE SOUND AND ACCEPTABLE STABLE STACKS. SHIM MATERIAL OF VARYING THICKNESSES WILL BE USED AS REQUIRED TO GAIN LEVEL OR NEARLY LEVEL STACKS AND SOLID BEARING WITHIN A STACK FROM THE FLOOR OF A MAGAZINE TO THE TOP OF THE STACK.

- N. OTHER COMPATIBLE ITEMS MAY BE STORED IN A MAGAZINE WHICH IS PARTIALLY FILLED WITH THE DESIGNATED ITEM.
- O. PORTIONS OF THE MAGAZINES, SUCH AS SIDEWALLS, END WALLS, AND ROOFS, HAVE NOT BEEN SHOWN IN THE STORAGE VIEWS FOR CLARITY PURPOSES.
- P. STORAGE OF MULTIPLE LOTS IN A MAGAZINE WILL REQUIRE CAREFUL PRE-PLANNING SO AS TO INSURE MHE ACCESSIBILITY TO ANY LOT IN ACCORDANCE WITH REQUIREMENTS SET FORTH IN THE APPLICABLE "SPECIAL NOTES" SECTIONS OF THE MULTIPLE LOT STORAGE PROCEDURES TYPICALLY SHOWN ON PAGES 22 THRU 28.
- Q. ALTHOUGH SPECIFIC PROCEDURES ARE INCLUDED IN THIS DRAWING FOR STORING MULTIPLE LOTS WITHIN ONE STRUCTURE, THE BASIC STORAGE PATTERN AS SHOWN ON PAGES 4 THRU 21 CAN ALSO BE ADAPTED FOR THE STORING OF MORE THAN ONE LOT. IN IGLOO, ARCH TYPE, STRADLEY AND STEEL ARCH MAGAZINES, WHEN STORED IN ACCORDANCE WITH THE BASIC STORAGE PATTERN, MULTIPLE LOTS OF PALLET UNITS MAY BE STORED WITH ONE OR MORE ROWS USED FOR EACH LOT. (A ROW RUNS FROM THE REAR OF A MAGAZINE TO THE FRONT). MULTIPLE LOTS OF PALLET UNITS MAY ALSO BE STORED WITH ONE OR MORE STACKS USED FOR EACH LOT. HOWEVER THE STACKS MUST BE REDUCED IN LENGTH TO PROVIDE AN MHE AISLE ALONG ONE SIDE OF THE MAGAZINE FOR MHE ACCESS TO ALL LOTS. IN CORBETTA AND RECTANGULAR MAGAZINES, WHEN STORED IN ACCORDANCE WITH THE BASIC STORAGE PATTERN, MULTIPLE LOTS OF PALLET UNITS MAY BE STORED WITH ONE OR MORE STACKS USED FOR EACH LOT. AN MHE AISLE MUST BE PROVIDED FROM THE DOOR TO THE REAR WALL OF THE MAGAZINE FOR MHE ACCESS TO ALL LOTS. IN ALL MAGAZINES, LOTS WILL NOT BE MIXED, EXCEPT TO THE EXTENT THAT UNITS OF ONE LOT WILL NOT BE STACKED ON TOP OF PALLET UNITS FROM ANOTHER LOT. EACH LOT WITHIN THE MAGAZINE MUST BE ACCESSIBLE FOR REMOVAL AND INSPECTION/INVENTORY IN ACCORDANCE WITH OTHER CRITERIA SPECIFIED IN THESE GENERAL NOTES AND IN THE SPECIAL NOTES ON PAGES 22 THRU 28.
- R. ANY "LIGHT" PALLET UNIT THAT DOES NOT CONTAIN A FULL QUANTITY OF ROCKETS WILL NOT BE BURIED IN STORAGE. IT MUST BE POSITIONED ADJACENT TO AN AISLE, PREFERABLY IN FRONT OF THE LOT.
- S. A PRODUCTION OR STORAGE FACILITY IS AUTHORIZED TO HAVE ONE INCOMPLETE, UN-BANDED PARTIAL UNIT LOAD PER LOT IN A STORAGE STRUCTURE. PRIOR TO SHIPMENT OF A PARTIAL UNIT, A LAYER MUST BE COMPLETED, IF APPLICABLE, BY THE POSITIONING OF ONE OR MORE FILLER ASSEMBLIES AS DELINEATED BY DRAWING 19-48-4116/800-20PA1002. THE UNIT MUST THEN BE RE-BANDED WITH THE SAME SIZE AND QUANTITY OF STRAPS AS THE ORIGINAL UNIT.
- T. CONVERSION TO METRIC EQUIVALENTS: DIMENSIONS WITHIN THIS DOCUMENT ARE EXPRESSED IN INCHES, AND WEIGHTS ARE EXPRESSED IN POUNDS. WHEN NECESSARY, THE METRIC EQUIVALENT MAY BE COMPUTED ON THE BASIS OF ONE INCH EQUALS 25.4 MM, AND ONE POUND EQUALS 0.454 KG.
- U. PALLET UNITS PRESENTLY STORED IN ACCORDANCE WITH A PRIOR APPROVED DRAWING NEED NOT BE RE-STORED SOLELY TO CONFORM TO THE PROCEDURES SPECIFIED IN THIS DOCUMENT.

(CONTINUED AT RIGHT)

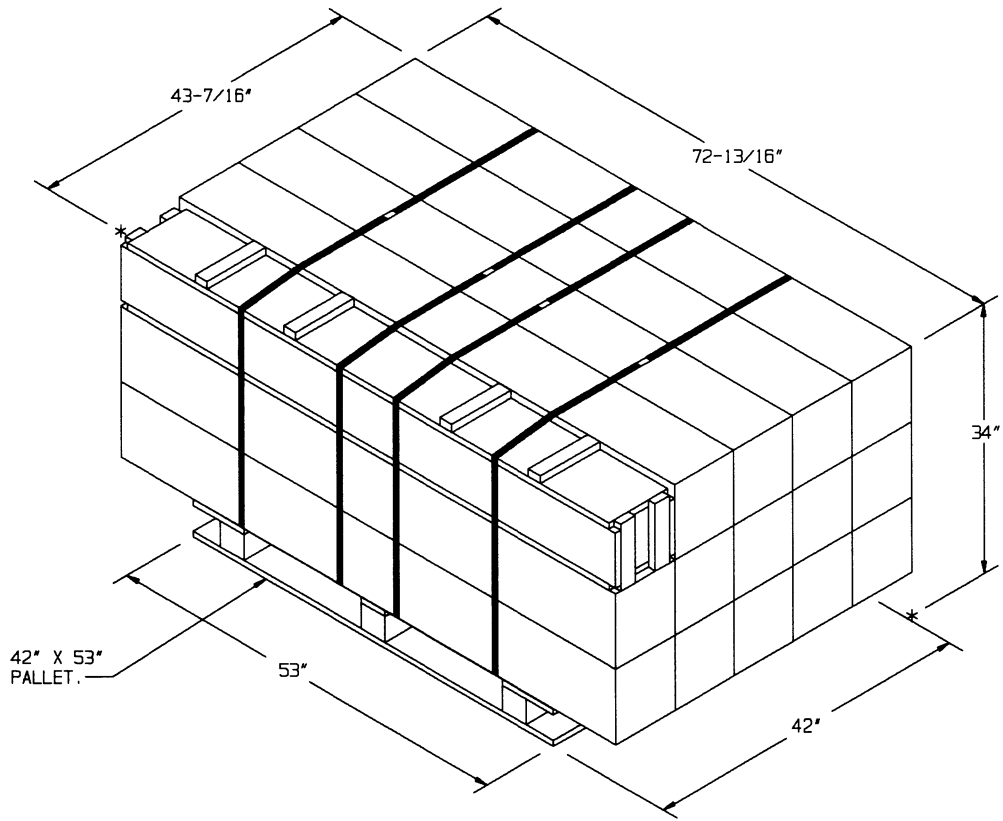

PALLET UNIT

SEE GENERAL NOTES "B" AND "C" ON PAGE 2.

STORAGE IN 81'-0" IGL00
(12'-9" HIGH)

ITEM	QUANTITY
PALLET UNIT - - - - -	211

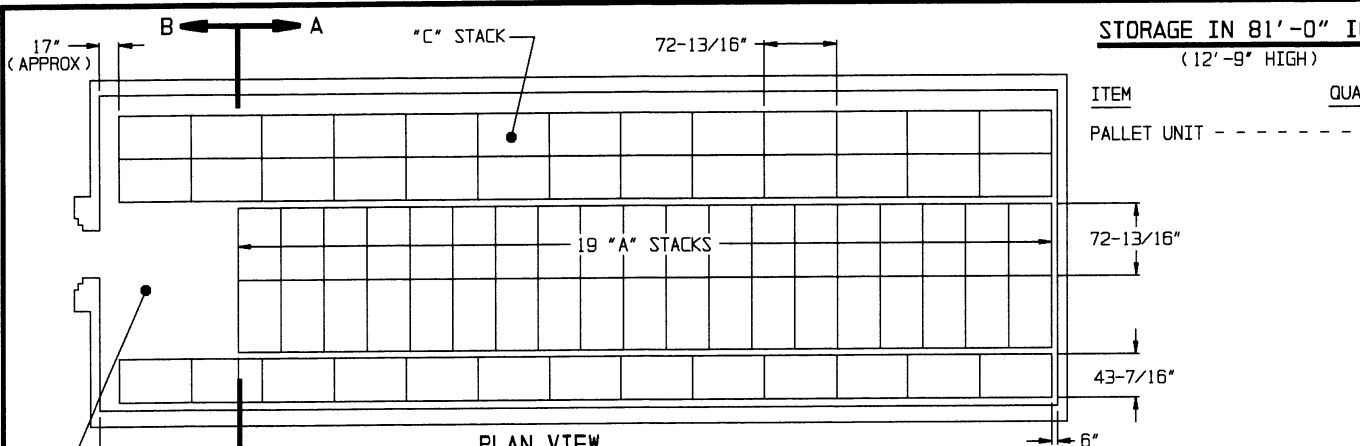

PLAN VIEW
(81'-0" IGL00)

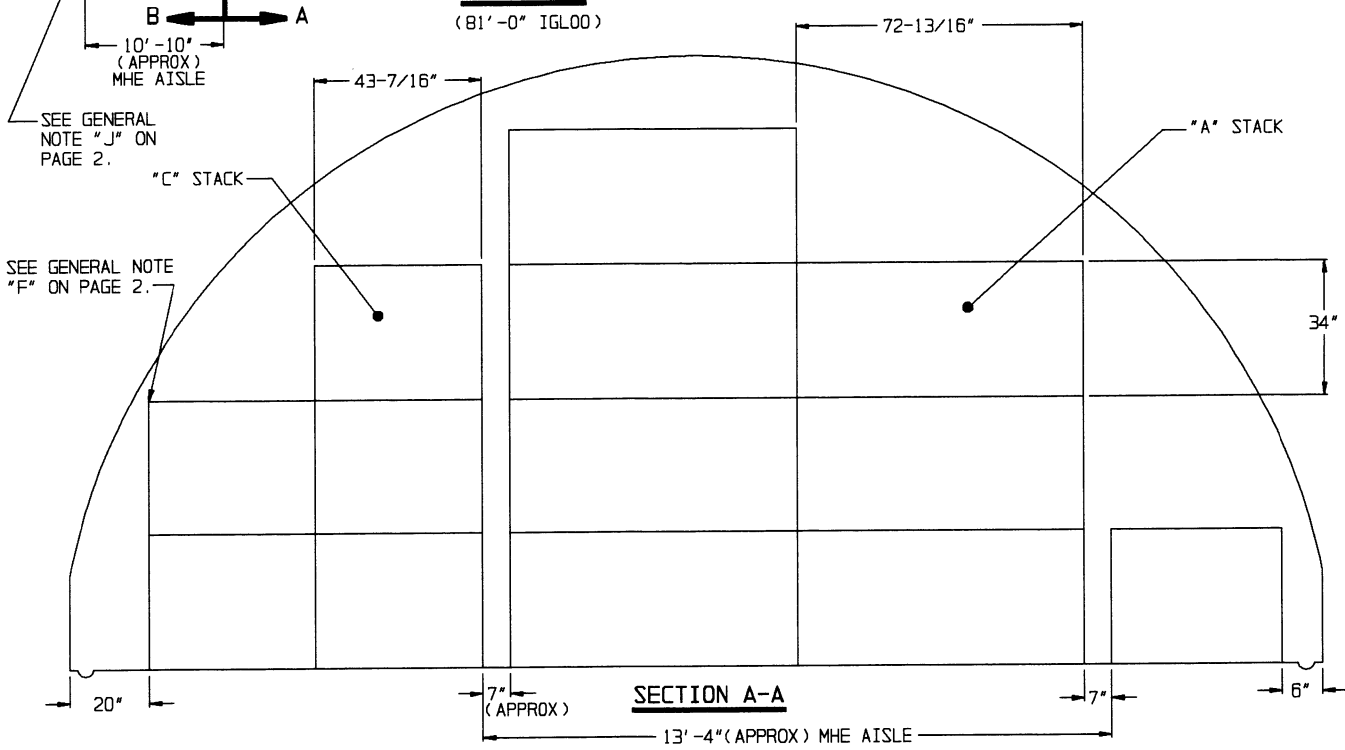

SECTION A-A

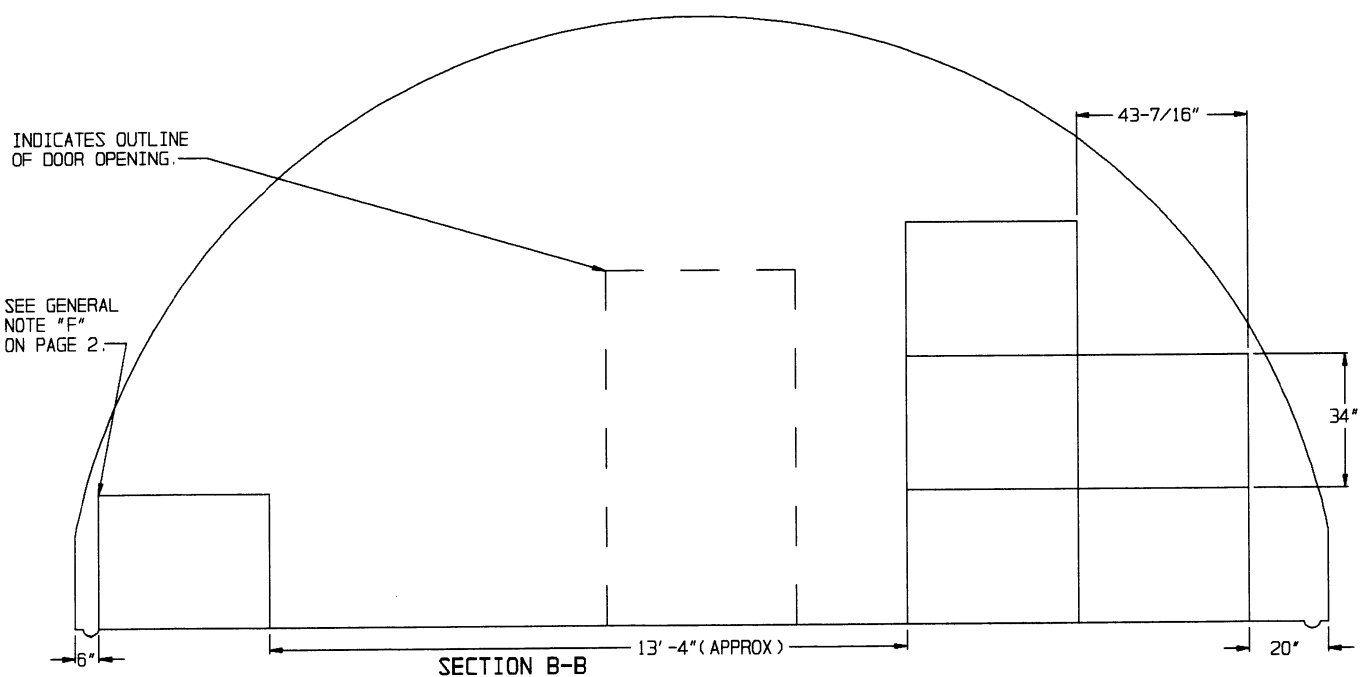

SECTION B-B

INDICATES OUTLINE OF DOOR OPENING.

SEE GENERAL NOTE "F" ON PAGE 2.

17" (APPROX)

10'-10" (APPROX) MHE AISLE

SEE GENERAL NOTE "J" ON PAGE 2.

SEE GENERAL NOTE "F" ON PAGE 2.

"C" STACK

"A" STACK

STORAGE PROCEDURES IN 81'-0", 60'-8", AND 40'-4" L X 26'-6" W X 12'-9" H IGL00 MAGAZINES

STORAGE IN 60'-8" IGLOO
(12'-9" HIGH)

ITEM	QUANTITY
PALLET UNIT - - - - -	145

***STORAGE IN 40'-4" IGLOO**
(12'-9" HIGH)

ITEM	QUANTITY
PALLET UNIT - - - - -	92

* 8 "A" STACKS
6 "C" STACKS

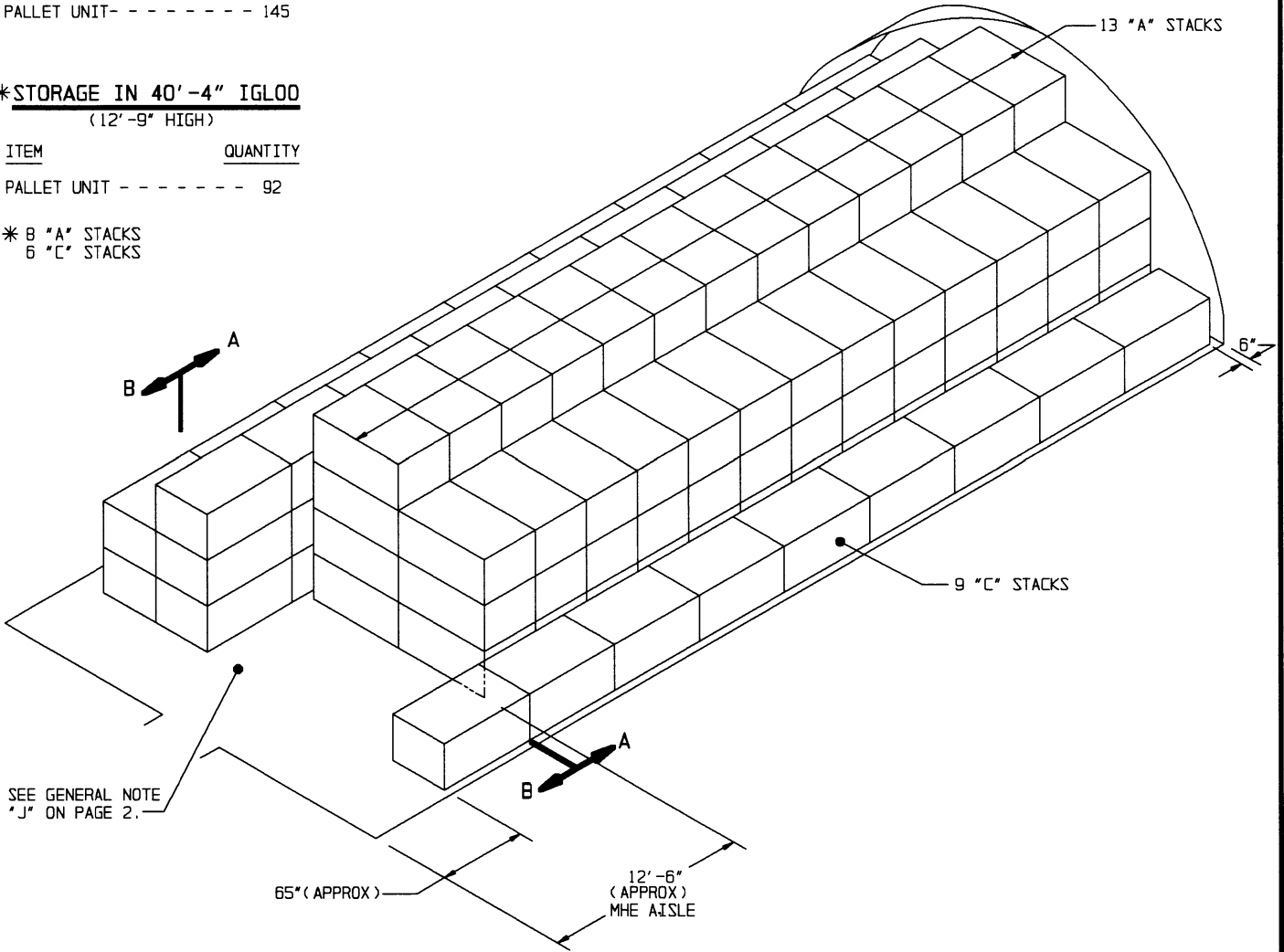

ISOMETRIC VIEW
(60'-8" IGLOO)

FOR "GENERAL NOTES" SEE PAGE 2.

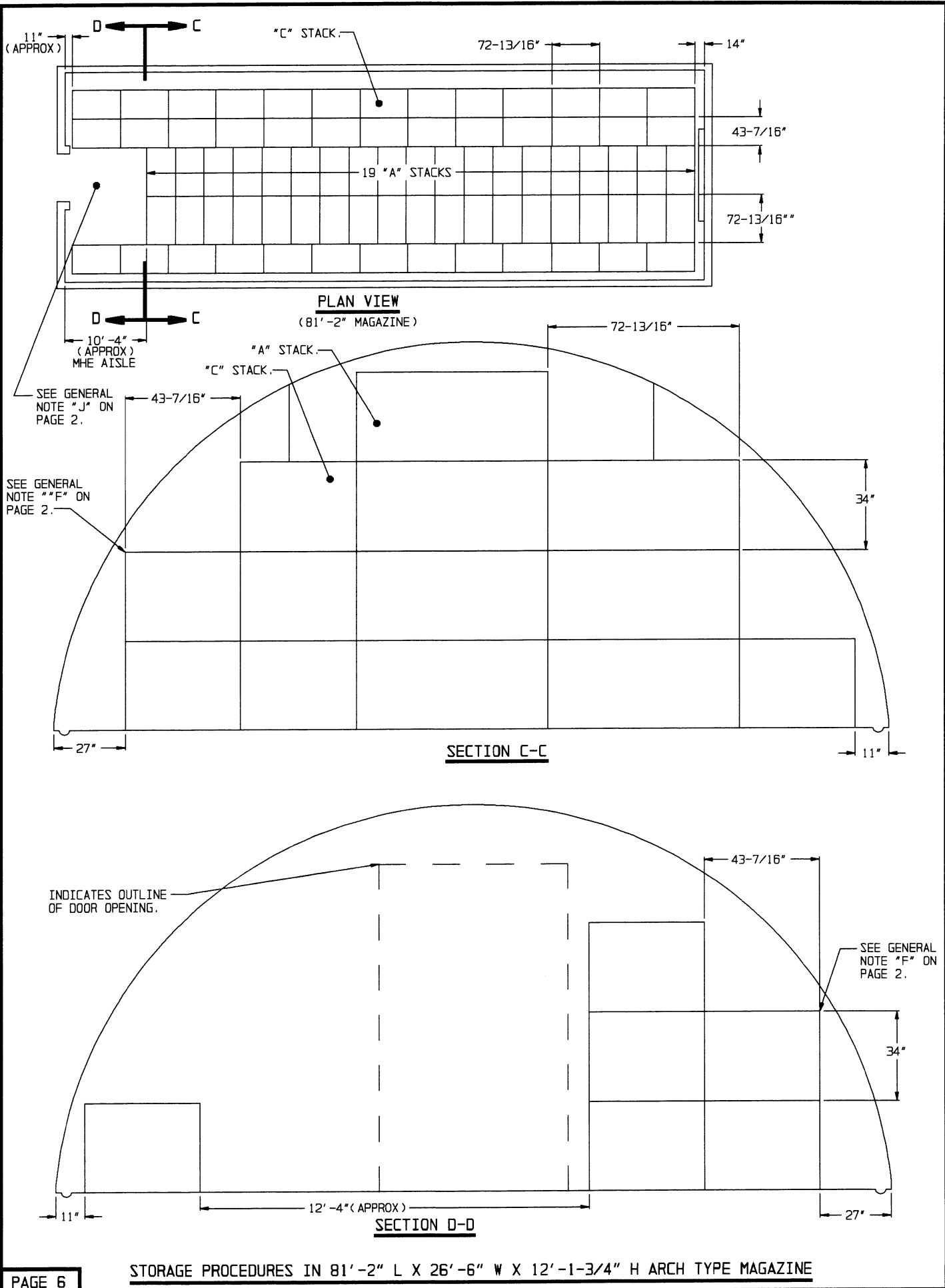

STORAGE PROCEDURES IN 81'-2" L X 26'-6" W X 12'-1-3/4" H ARCH TYPE MAGAZINE

STORAGE IN 81'-2" MAGAZINE

(12'-1-3/4" HIGH)

ITEM

QUANTITY

PALLET UNIT - - - - - 211

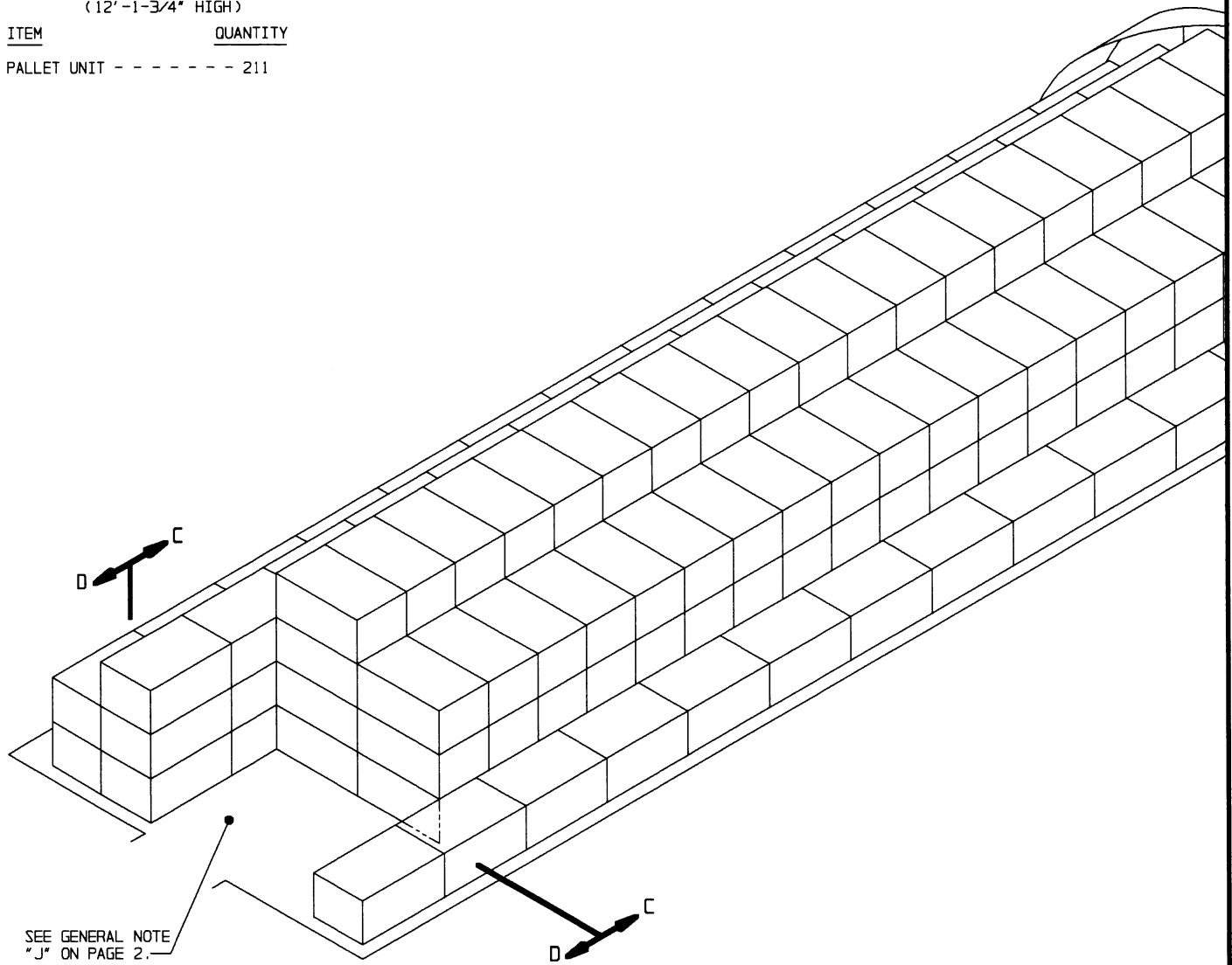

SEE GENERAL NOTE
"J" ON PAGE 2.

ISOMETRIC VIEW
(81'-2" MAGAZINE)

FOR "GENERAL NOTES" SEE PAGE 2.

STORAGE IN 80'-0" MAGAZINE
(12'-1-3/4" HIGH)

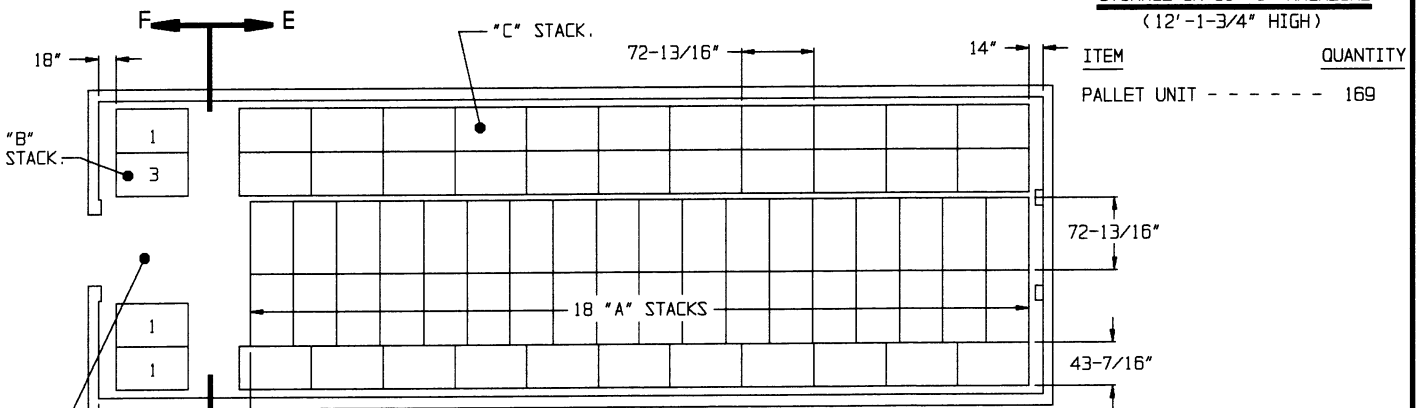

PLAN VIEW
(80'-0" MAGAZINE)

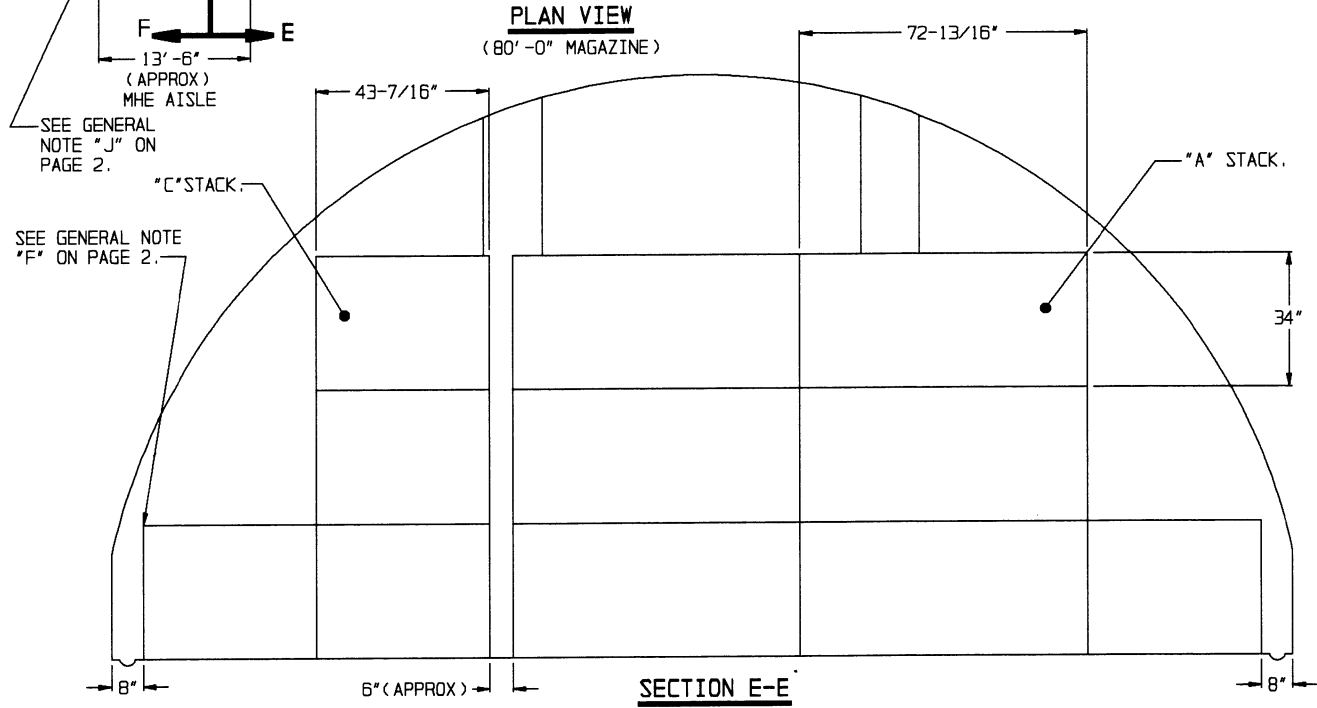

SECTION E-E

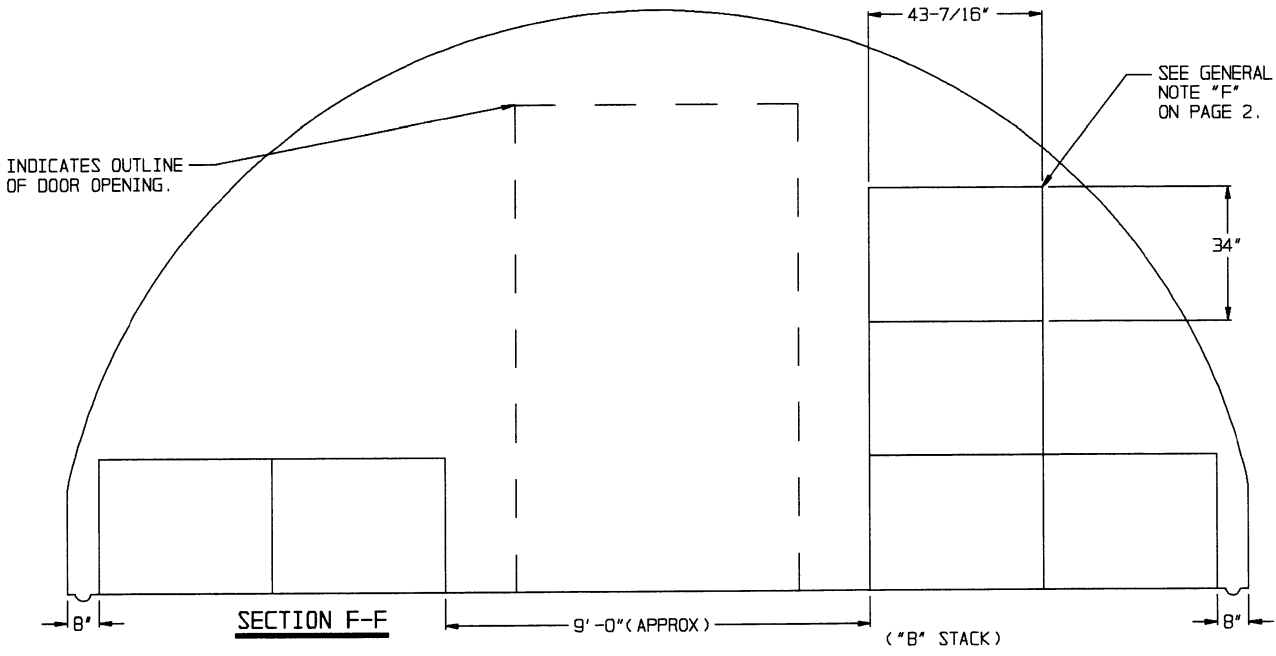

SECTION F-F

STORAGE IN 40'-0" MAGAZINE

(12'-1-3/4" HIGH)

ITEM

QUANTITY

PALLET UNIT - - - - - 79

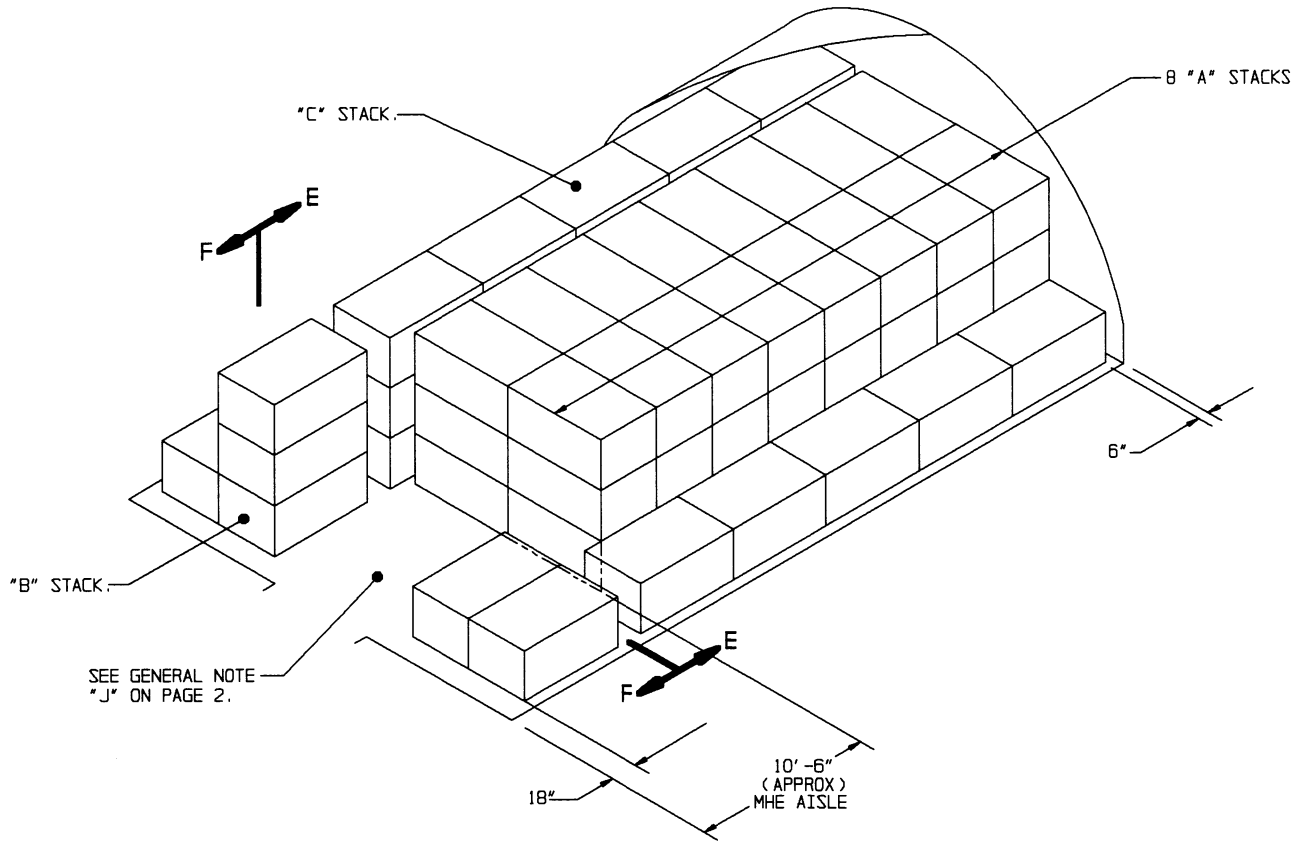

ISOMETRIC VIEW
(40'-0" MAGAZINE)

FOR "GENERAL NOTES" SEE PAGE 2.

STORAGE IN 80'-0" MAGAZINE

(11'-0" HIGH)

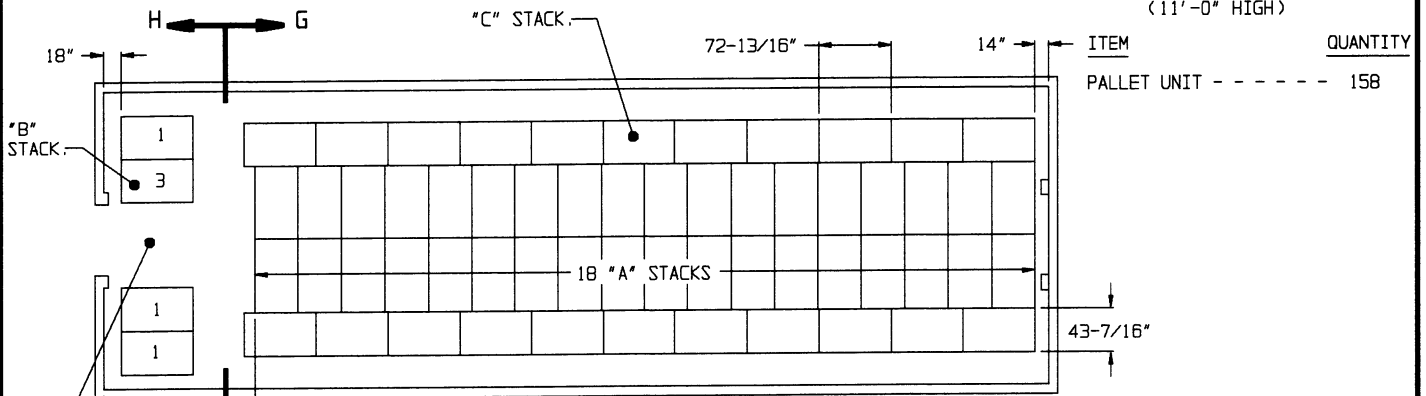

PLAN VIEW
(80'-0" MAGAZINE)

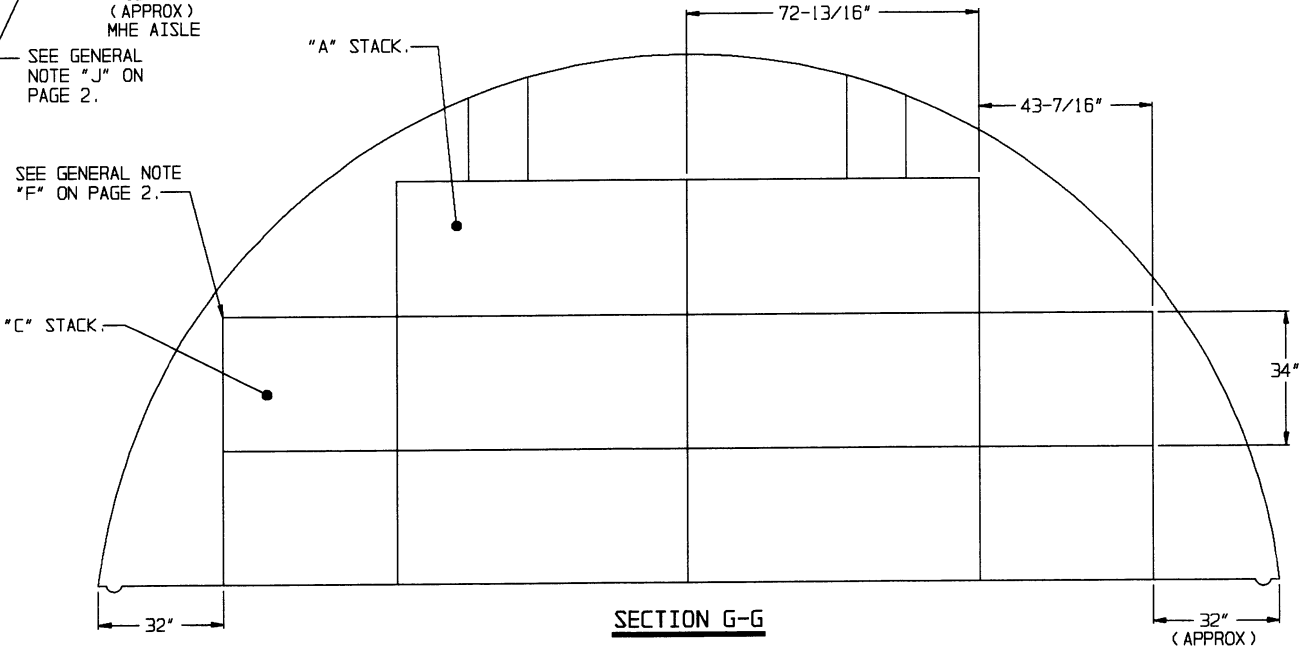

SECTION G-G

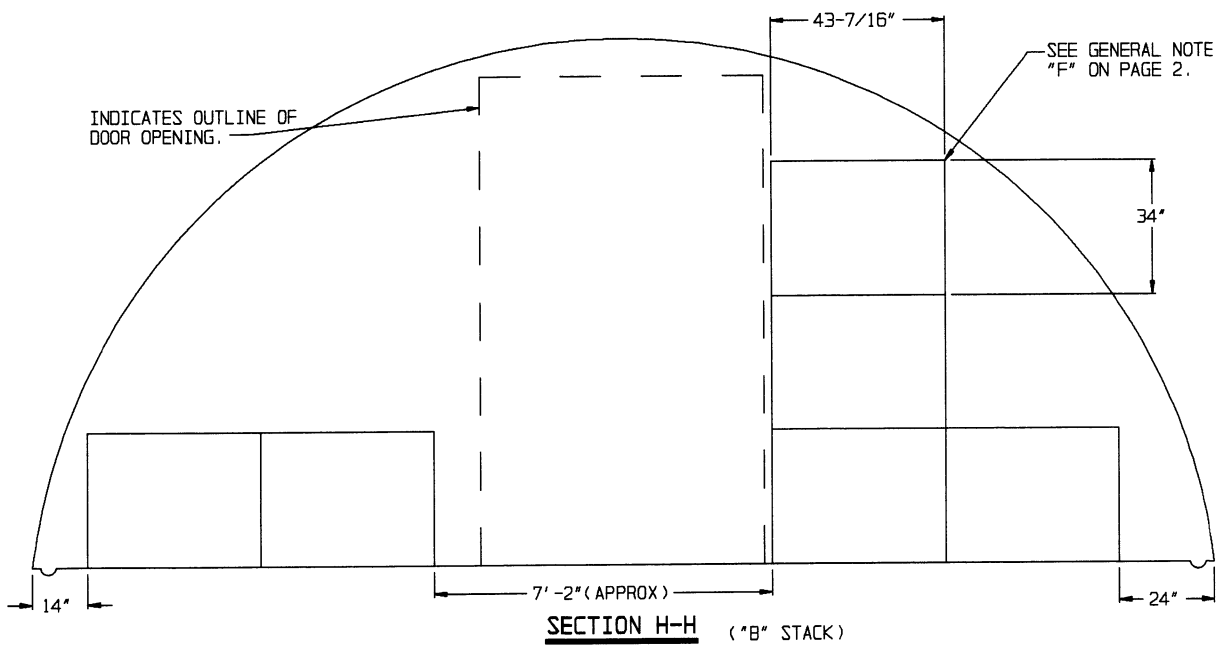

SECTION H-H ("B" STACK)

STORAGE IN 40'-0" MAGAZINE

(11'-0" HIGH)

ITEM

QUANTITY

PALLET UNIT - - - - - 68

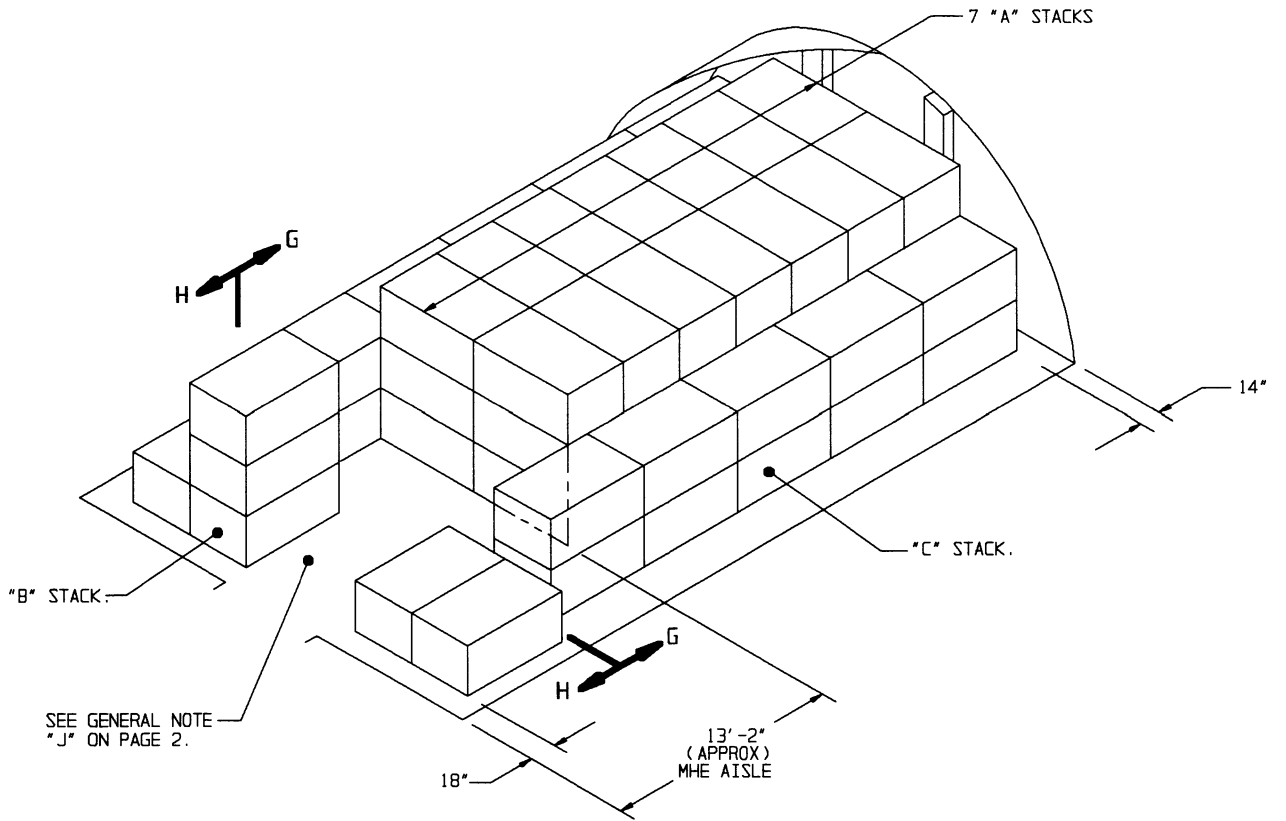

ISOMETRIC VIEW
(40'-0" MAGAZINE)

FOR "GENERAL NOTES" SEE PAGE 2.

STORAGE IN 80'-0" MAGAZINE

(10'-0" HIGH)

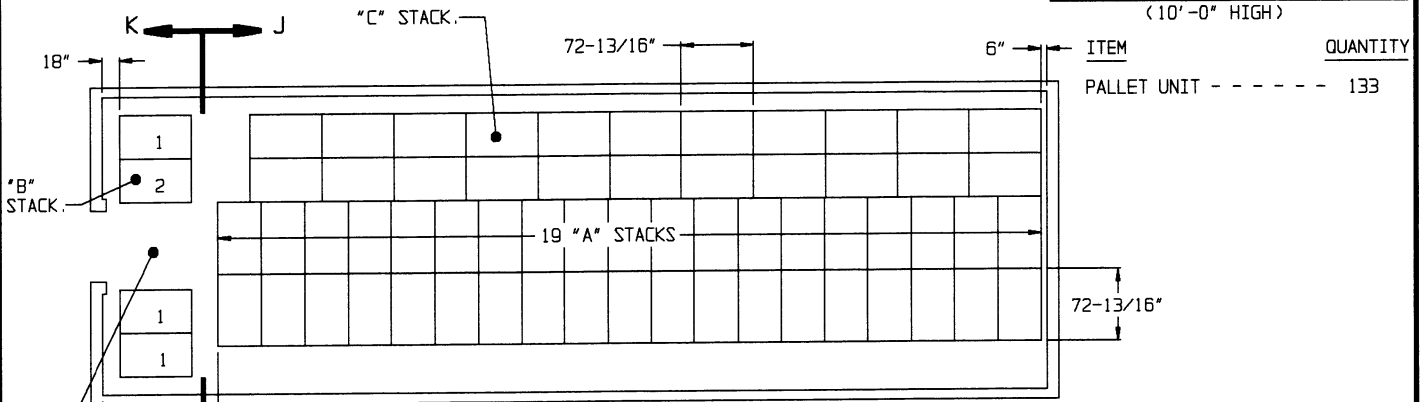

PLAN VIEW
(80'-0" MAGAZINE)

SEE GENERAL NOTE "J" ON PAGE 2.

SEE GENERAL NOTE "F" ON PAGE 2.

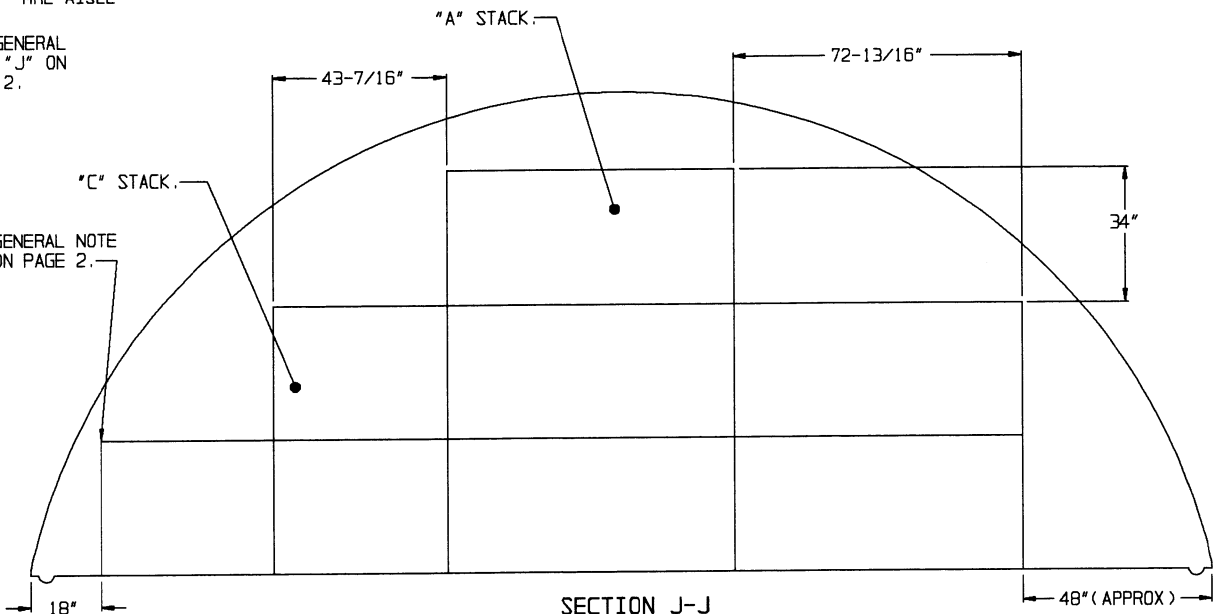

SECTION J-J

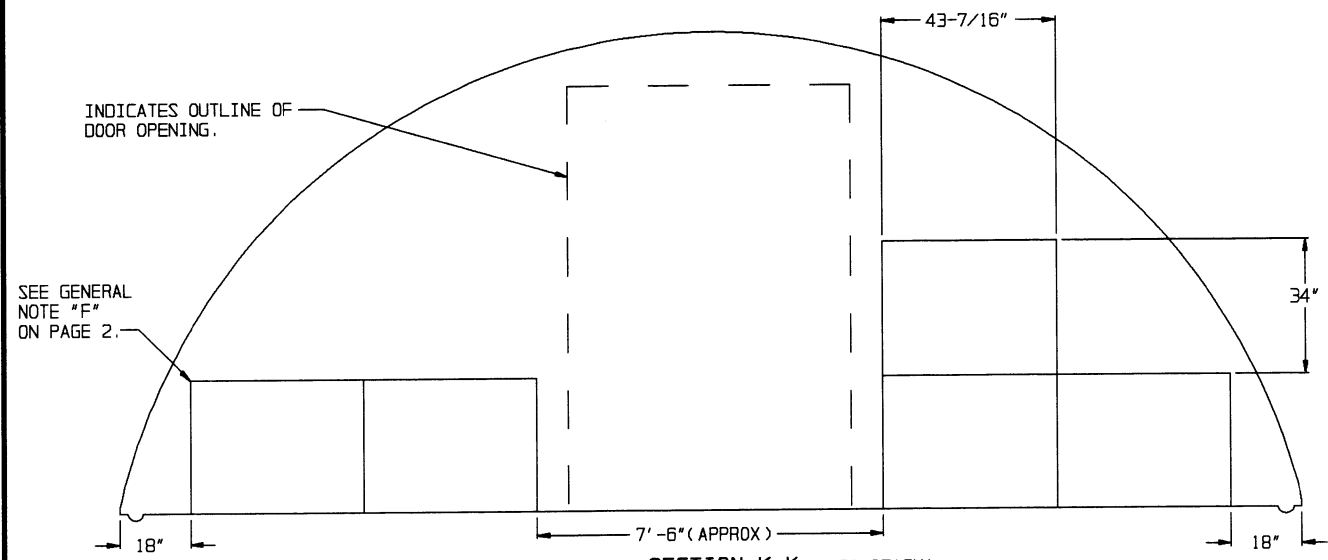

SECTION K-K ("B" STACK)

STORAGE IN 40'-0" MAGAZINE

(10'-0" HIGH)

<u>ITEM</u>	<u>QUANTITY</u>
PALLET UNIT - - - - -	60

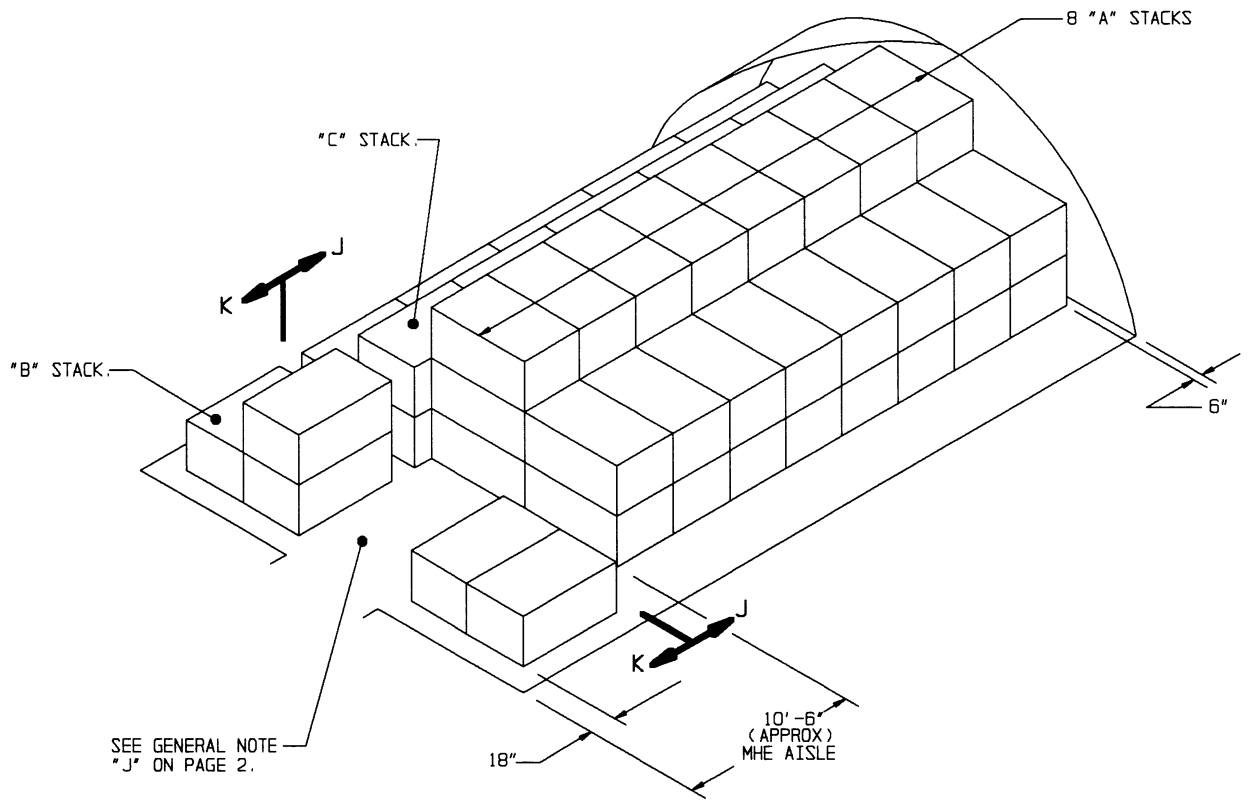

ISOMETRIC VIEW
(40'-0" MAGAZINE)

FOR "GENERAL NOTES" SEE PAGE 2.

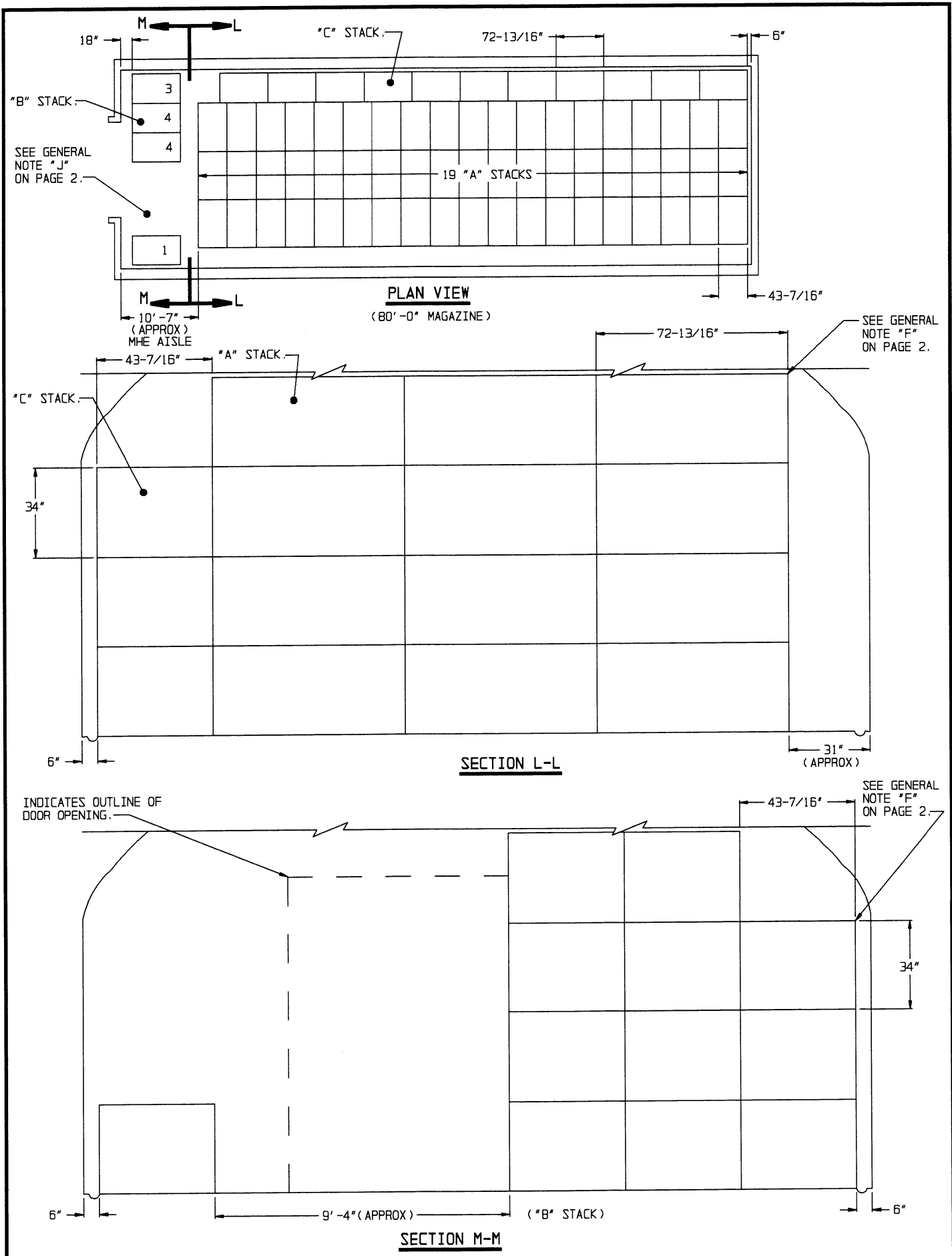

STORAGE IN 80'-0" MAGAZINE
(14'-0" HIGH)

<u>ITEM</u>	<u>QUANTITY</u>
PALLET UNIT - - - - -	273

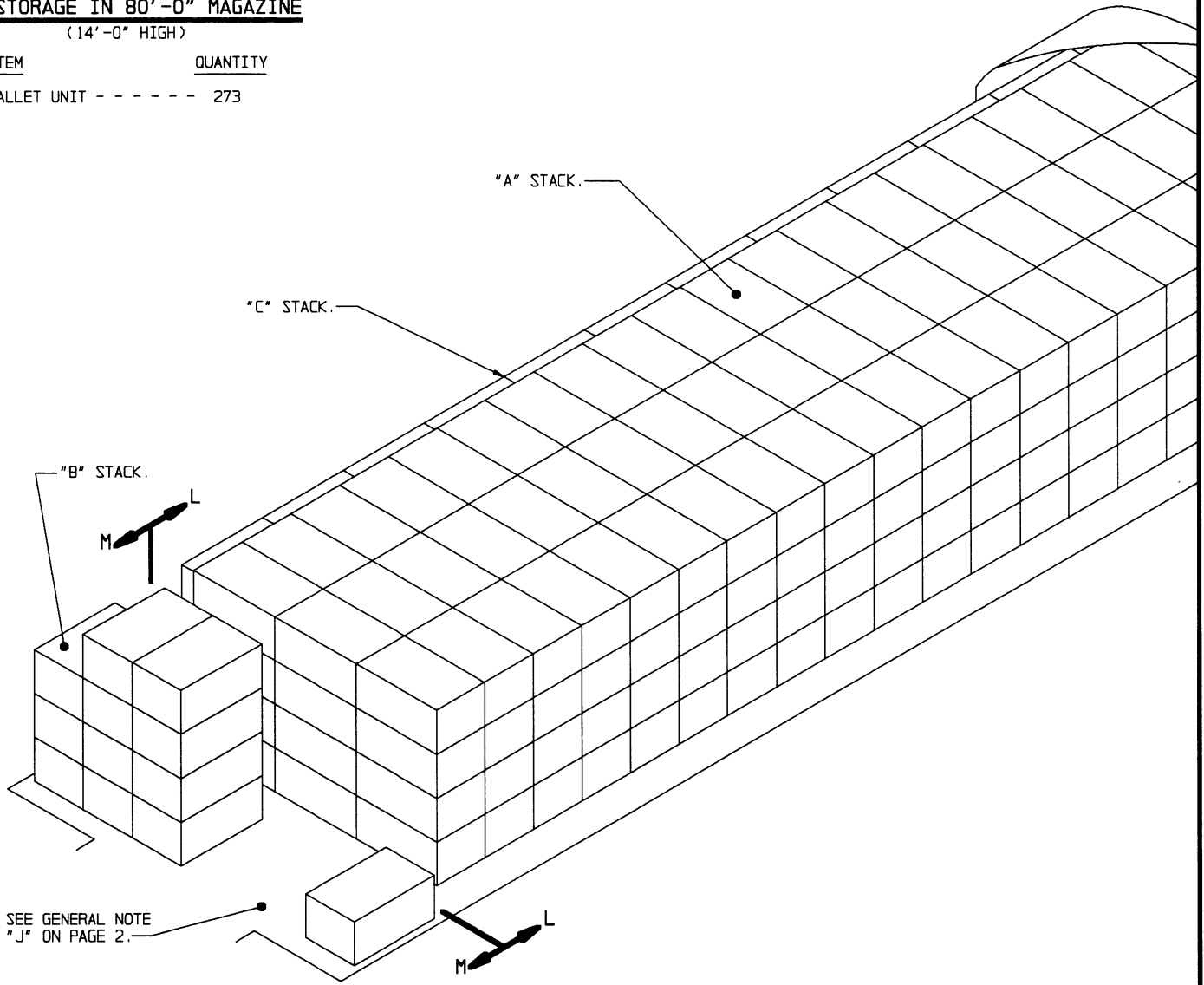

FOR "GENERAL NOTES" SEE PAGE 2.

ISOMETRIC VIEW
(80'-0" MAGAZINE)

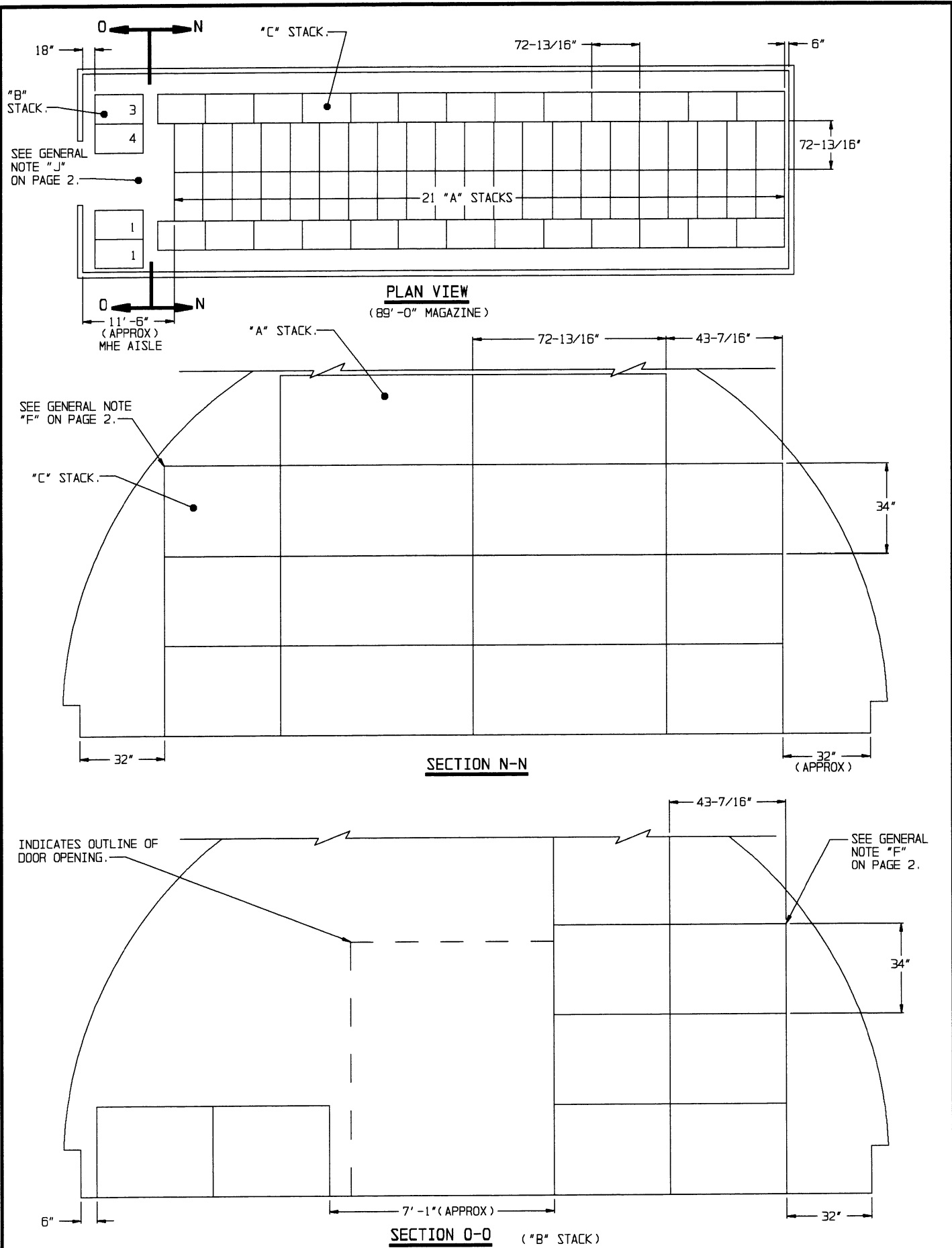

STORAGE IN 89'-0" MAGAZINE
(13'-6" HIGH)

<u>ITEM</u>	<u>QUANTITY</u>
PALLET UNIT - - - - -	255

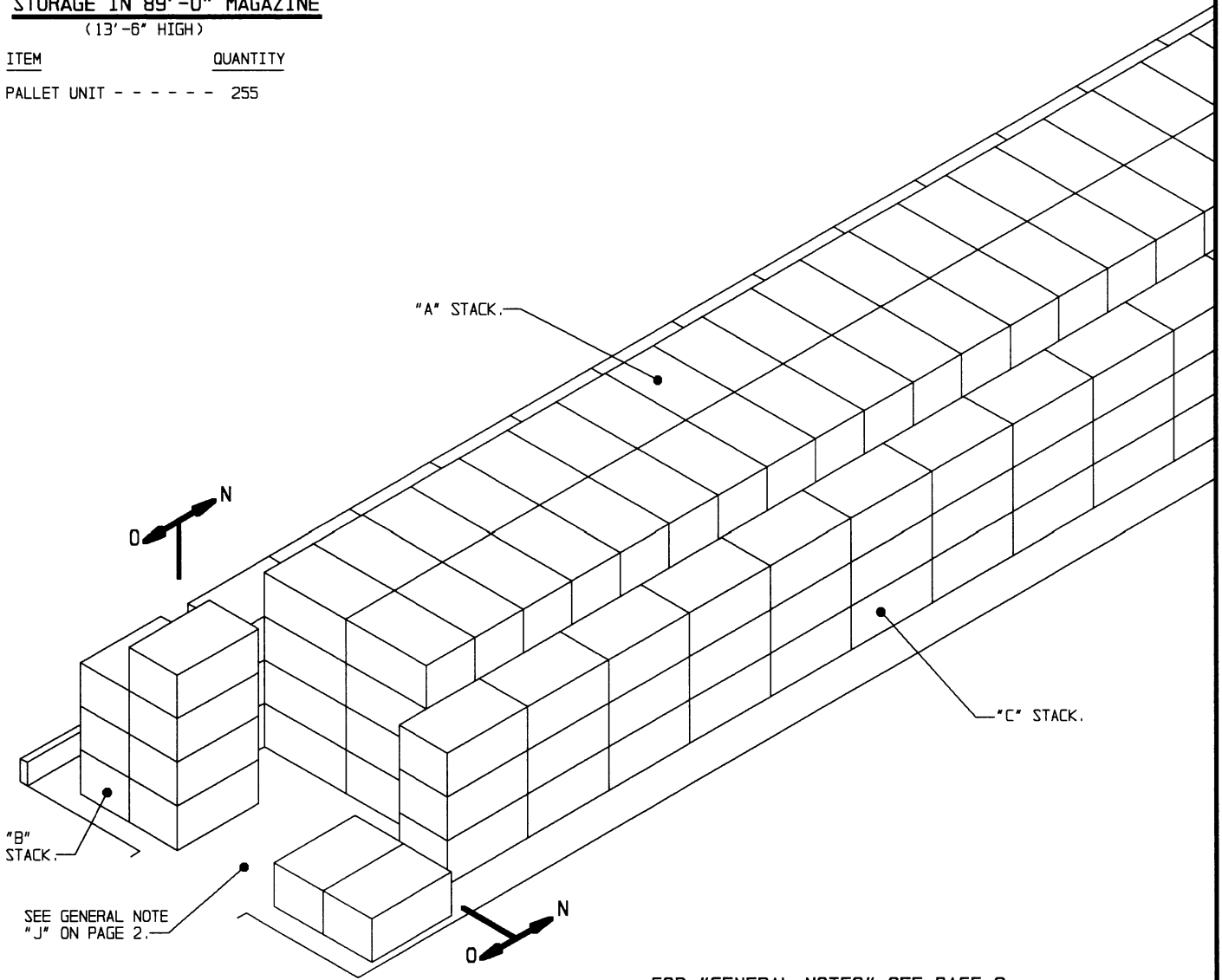

SEE GENERAL NOTE
"J" ON PAGE 2.

FOR "GENERAL NOTES" SEE PAGE 2.

ISOMETRIC VIEW
(89'-0" MAGAZINE)

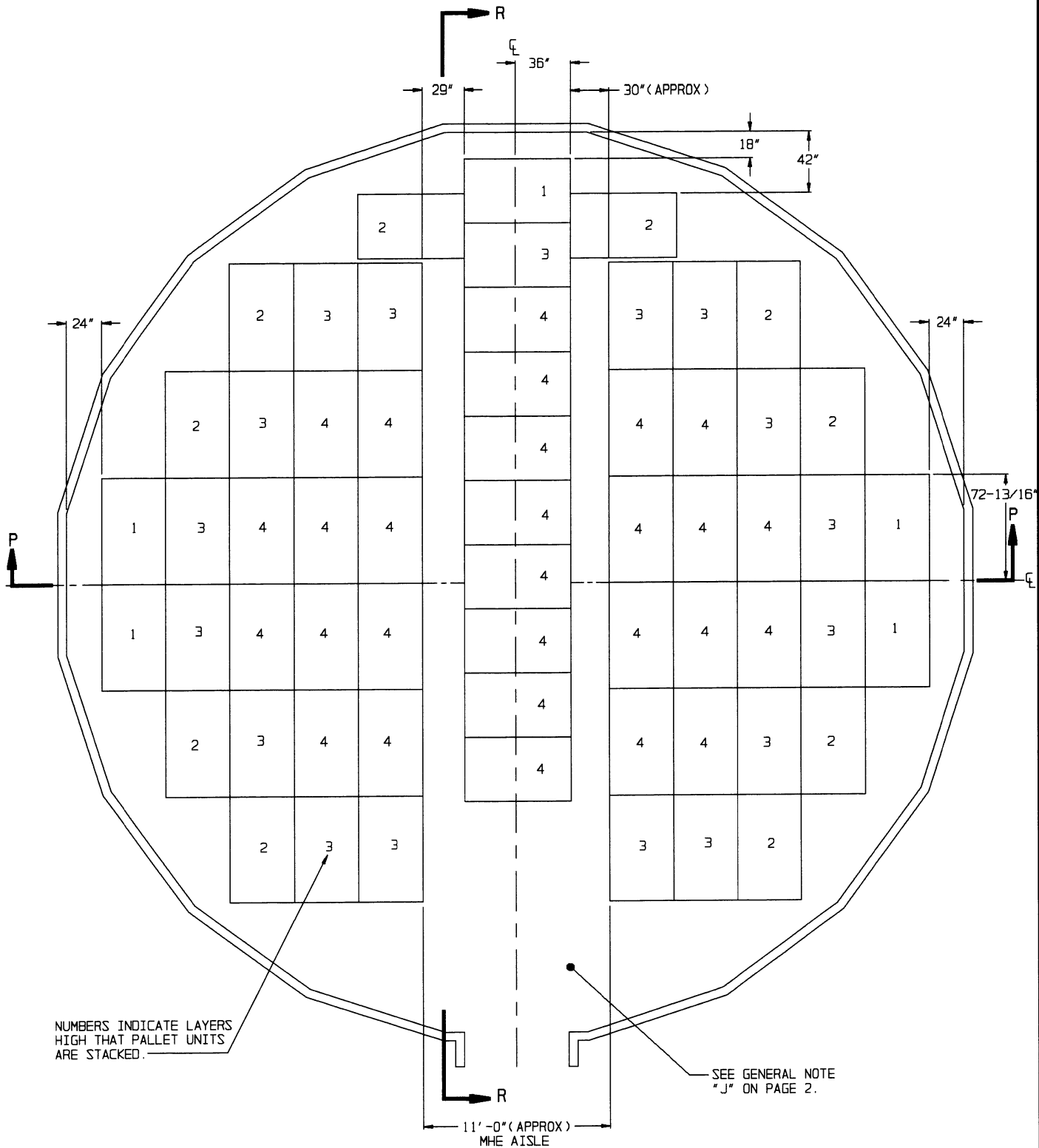

PLAN VIEW
(52'-0" DIA MAGAZINE)

STORAGE PROCEDURES IN 52'-0" DIA CORBETTA MAGAZINE

STORAGE IN 52'-0" DIA MAGAZINE

ITEM	QUANTITY
PALLET UNIT - - - - -	188

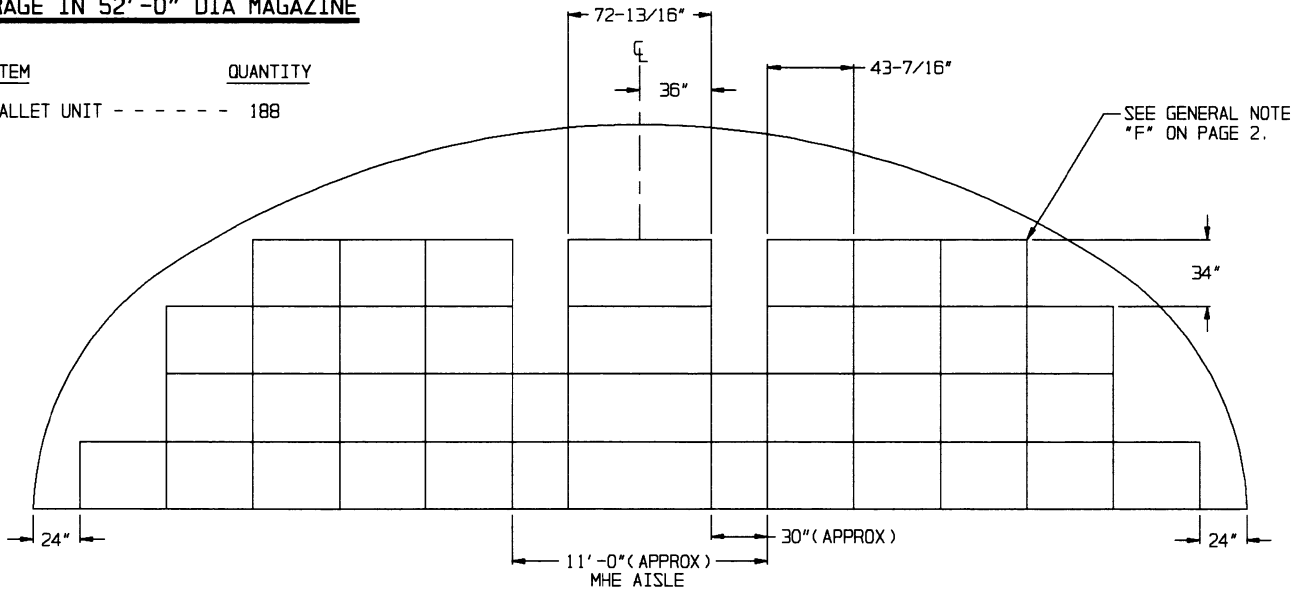

SEE GENERAL NOTE "F" ON PAGE 2.

SECTION P-P

ONLY ONE OF THE ROWS OF PALLET UNITS IS SHOWN IN THIS SECTION. PALLET UNITS LOCATED IN ADJACENT ROWS OR STACKS HAVE NOT BEEN SHOWN FOR CLARITY PURPOSES.

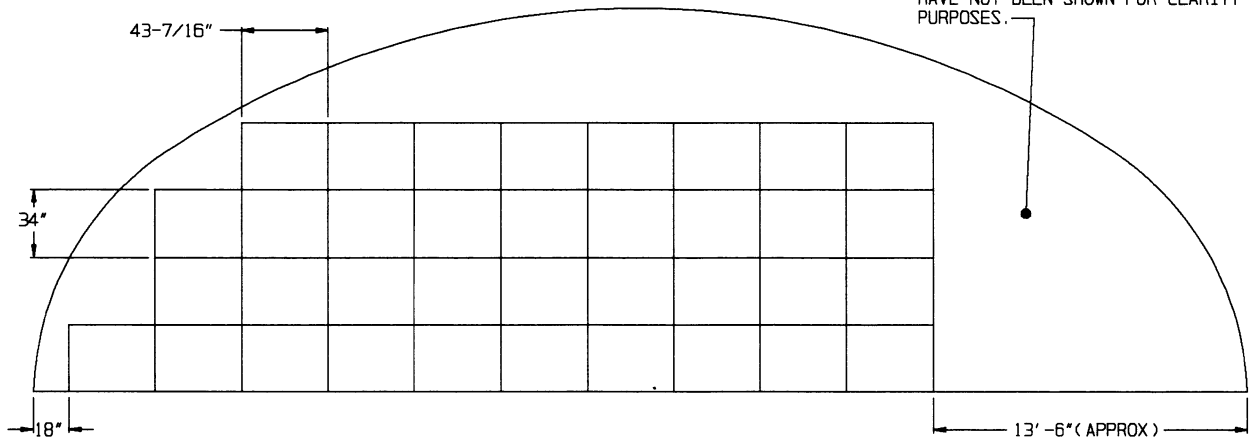

SECTION R-R

FOR "GENERAL NOTES" SEE PAGE 2.

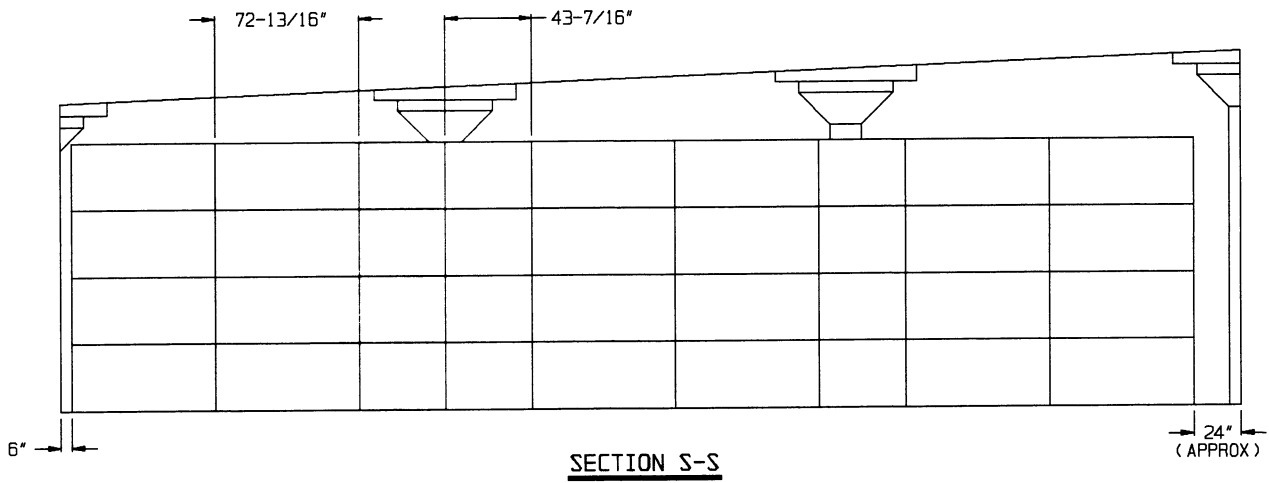
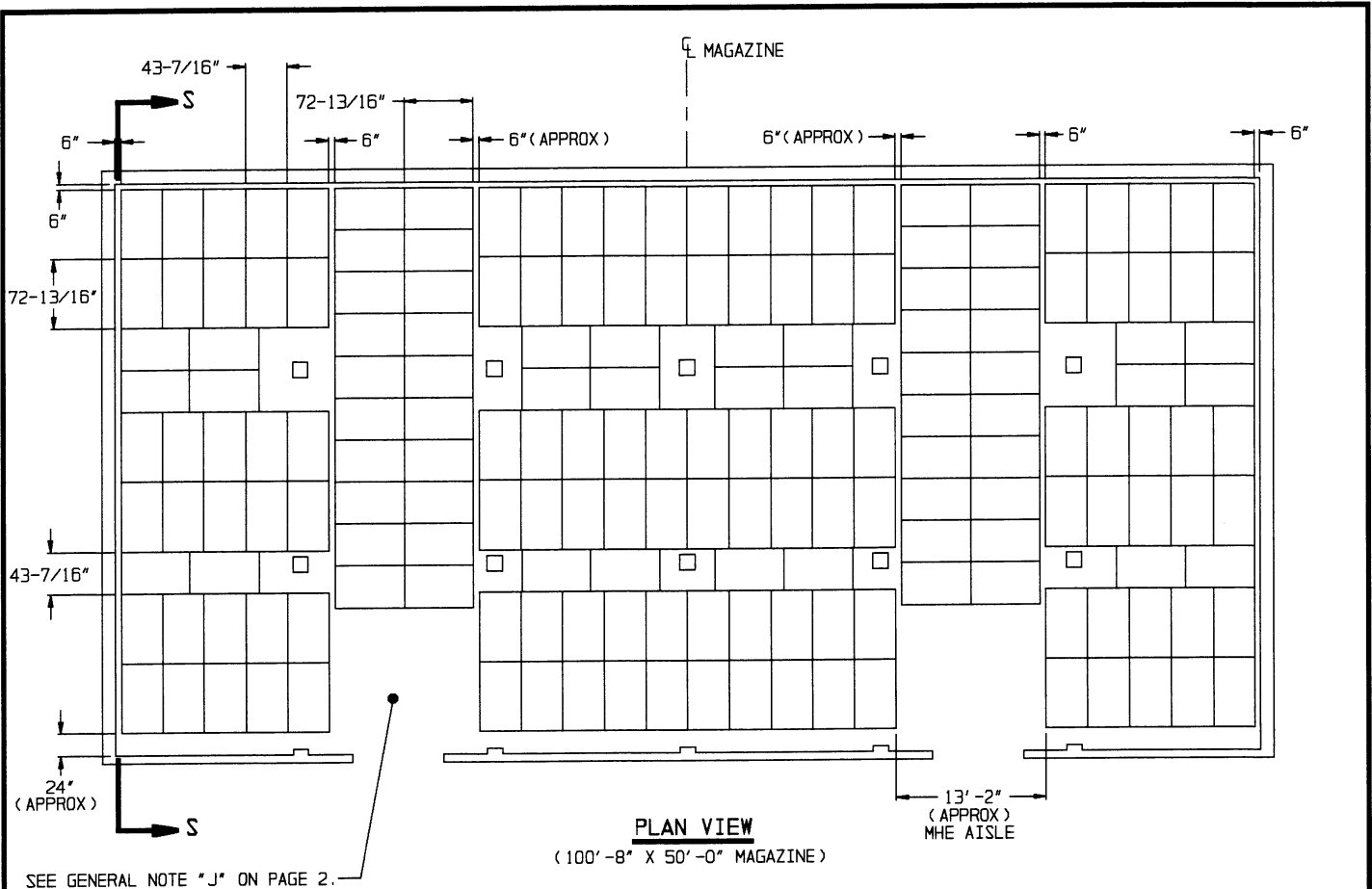

STORAGE IN 100'-8" X 50'-0" MAGAZINE

<u>ITEM</u>	<u>QUANTITY</u>
PALLET UNIT - - - - -	736

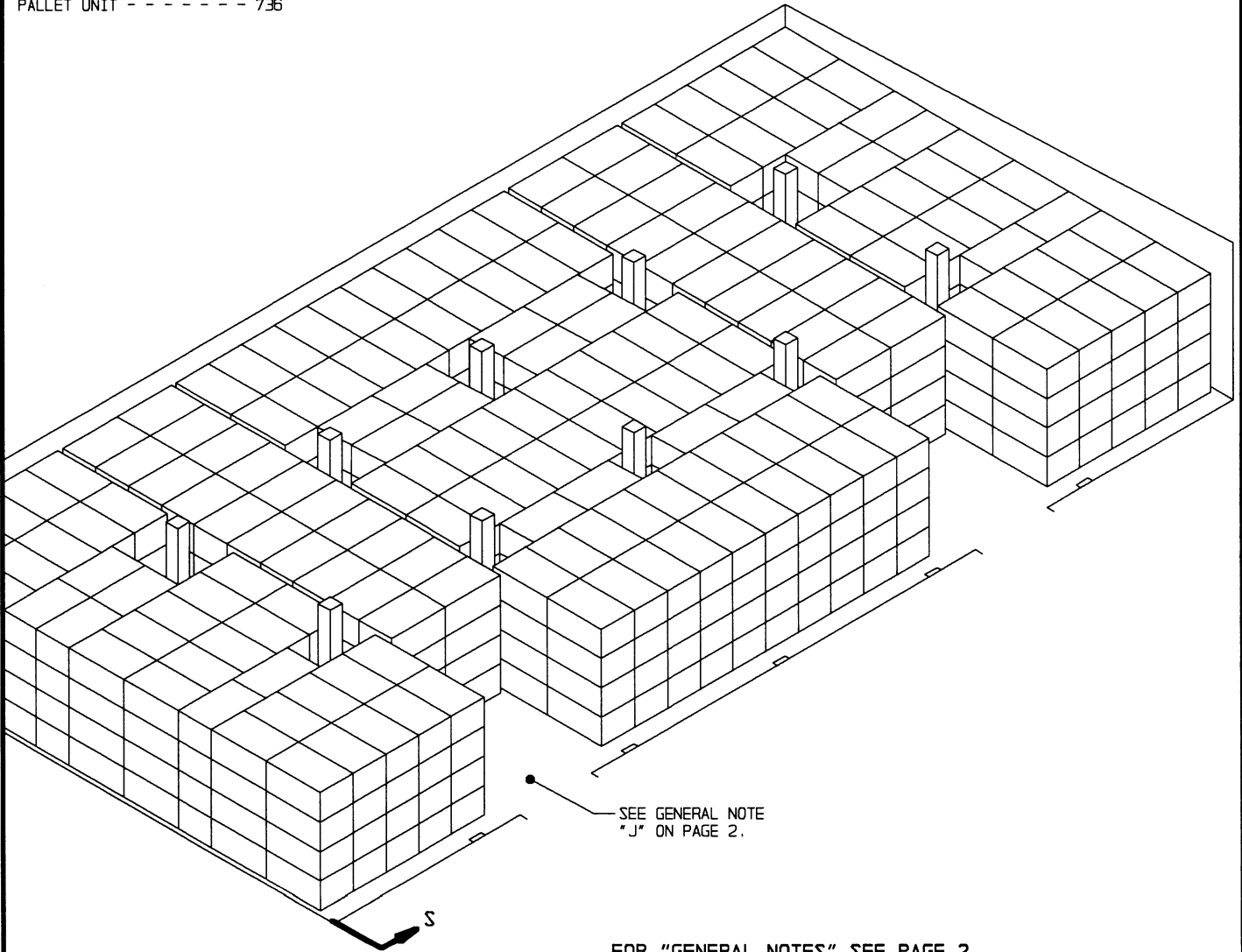

ISOMETRIC VIEW
(100'-8" X 50'-0" MAGAZINE)

SEE GENERAL NOTE
J ON PAGE 2.

FOR "GENERAL NOTES" SEE PAGE 2.

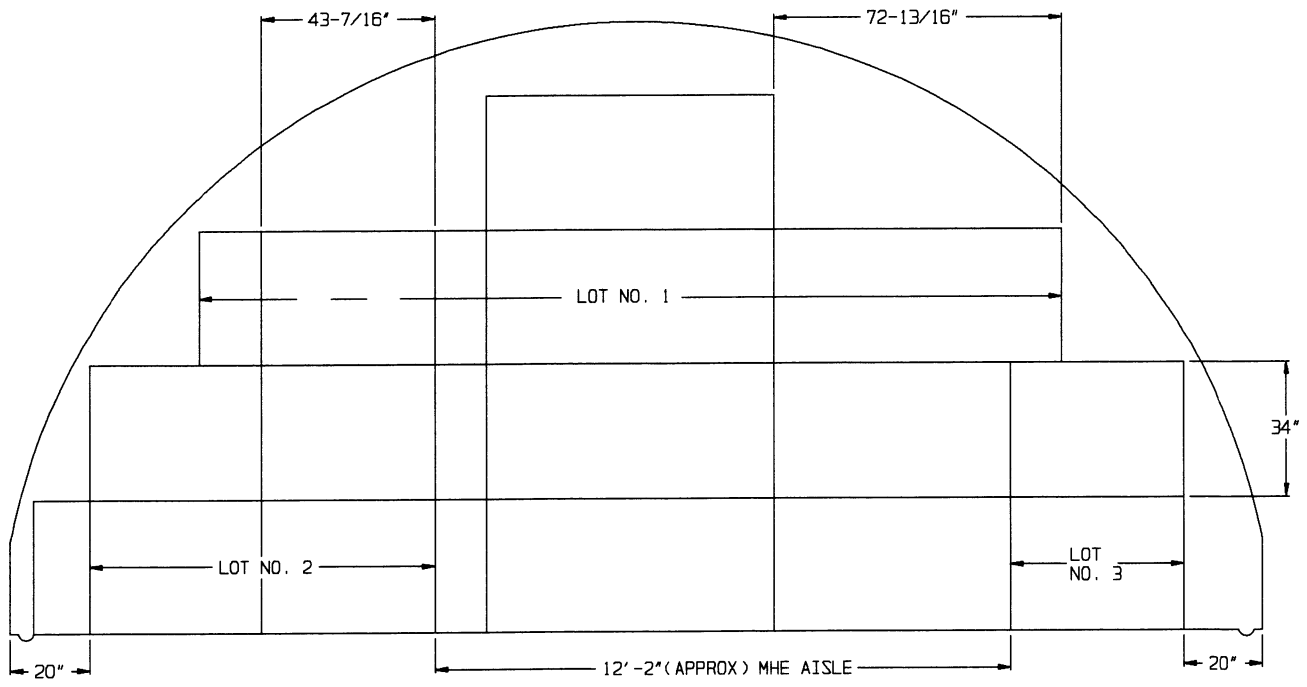
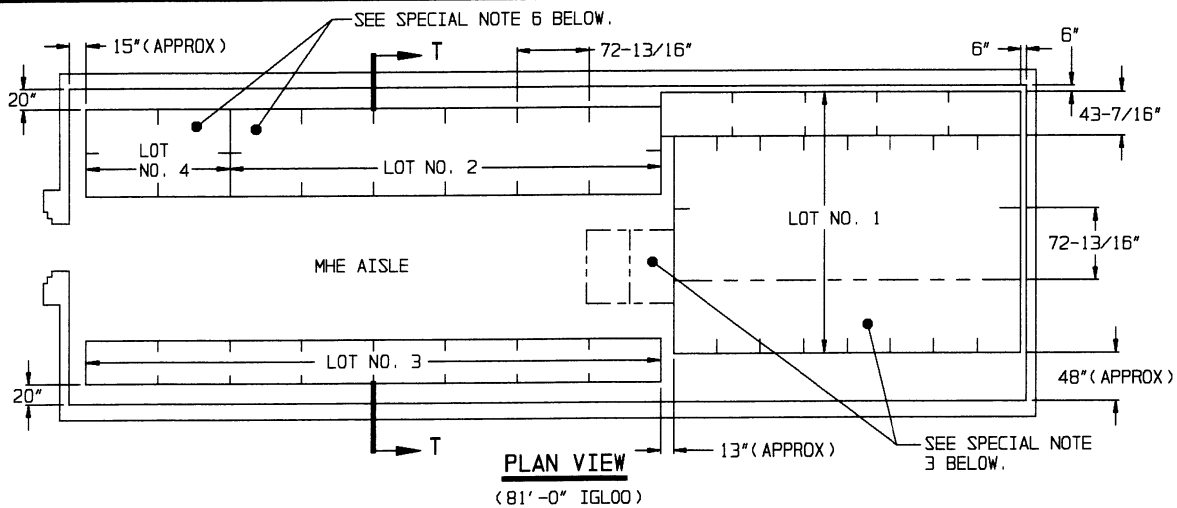

SECTION T-T

SPECIAL NOTES:

(SPECIAL NOTES CONTINUED)

1. THE STORAGE PLANS AND CONFIGURATIONS SHOWN ON THIS PAGE ARE TYPICAL ONLY, AND APPLY TO RELATIVELY LARGE LOTS. ADAPTATIONS MAY BE MADE AS NUMBER AND SIZES OF LOTS TO BE STORED IN MAGAZINE REQUIRE.
2. AN INSPECTION/INVENTORY AISLE MUST BE PROVIDED AT ONE SIDE OR END OF EACH LOT.
3. GENERALLY, THE LARGEST LOT SHOULD BE STORED IN THE REAR OF THE MAGAZINE, HOWEVER, THE REAR AREA MAY BE USED TO STORE MORE THAN ONE LOT, AS SHOWN BY PHANTOM LINES, AND EACH LOT MUST BE ACCESSIBLE FOR REMOVAL AND INSPECTION/INVENTORY IN ACCORDANCE WITH OTHER CRITERIA SPECIFIED IN THESE SPECIAL NOTES AND IN THE GENERAL NOTES ON PAGE 2.
4. EACH LOT WITHIN THE MAGAZINE MUST BE ACCESSIBLE FOR MOVEMENT BY MHE. A SINGLE-LOT OF PALLET UNITS IS CONSIDERED "ACCESSIBLE" IF NO MORE THAN TWELVE (12) "LIFTS" OF ANOTHER LOT OR LOTS HAVE TO BE MADE TO GAIN ACCESS TO THAT LOT. A LIFT MAY CONSIST OF ONE (1) OR MORE PALLET UNITS, PROVIDING THE CAPACITY OF MHE PERMITS, AND SAFE HANDLING IS NOT JEOPARDIZED.
5. FOR STORAGE OF MULTIPLE LOTS, THE DISTANCE FROM THE SIDEWALL WILL BE BASED ON THE OVERHEAD CLEARANCE REQUIRED FOR MHE.
6. WHEN TWO LOTS ARE STORED ADJACENT TO EACH OTHER, THEY SHOULD BE SEPARATED BY AT LEAST 1" TO PROVIDE CLEARANCE FOR REMOVAL OF EITHER LOT.
7. A 12'-2" MHE AISLE HAS BEEN SHOWN. THE MHE AISLE SHOULD BE MADE SMALLER IF AVAILABLE MHE PERMITS. THE AISLE IS TO BE AT LEAST 78" INCHES WIDE. AN AISLE SLIGHTLY WIDER THAN 78" INCHES WILL ENHANCE FORKLIFT TRUCK MOVEMENT WITHIN A MAGAZINE.

(CONTINUED AT RIGHT)

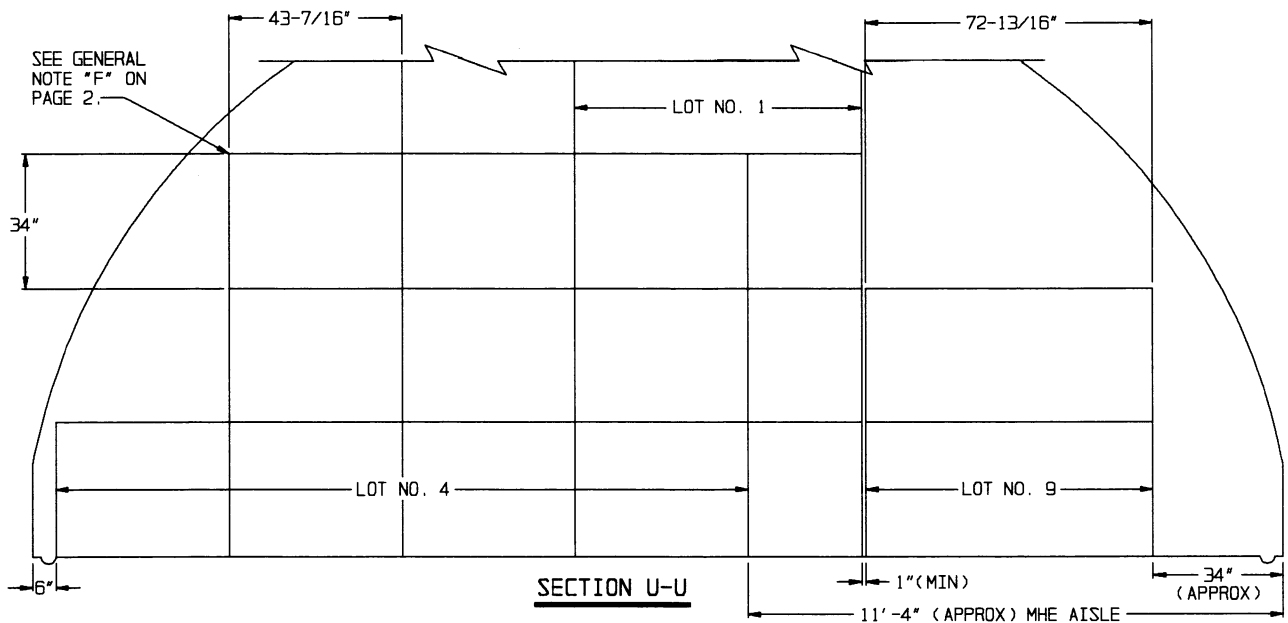
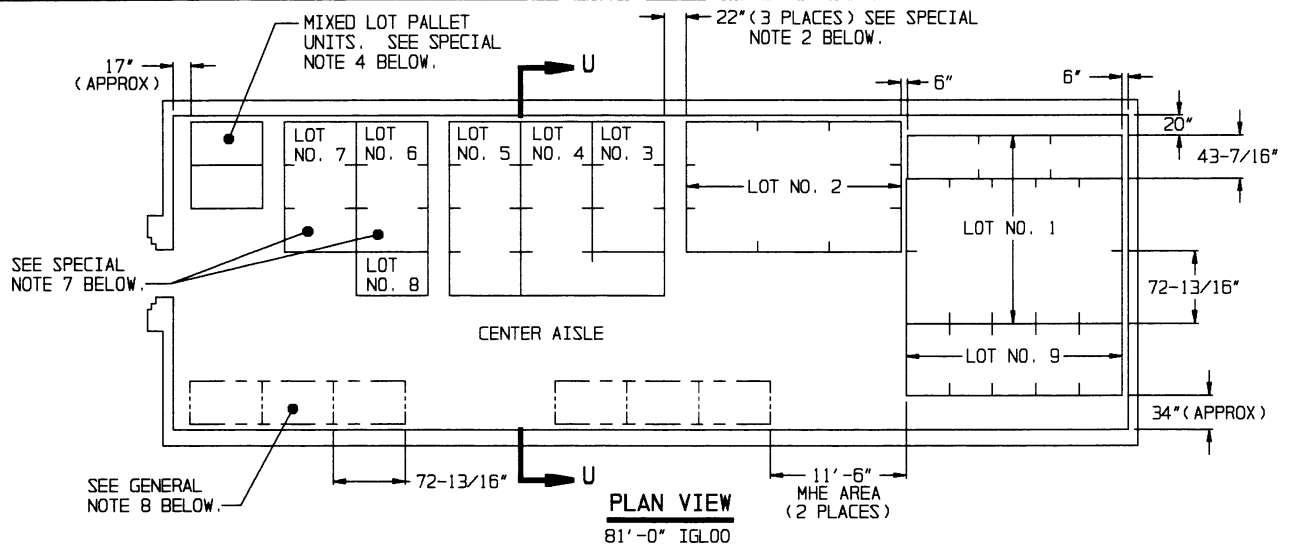

SPECIAL NOTES:

1. THE STORAGE PLANS AND CONFIGURATIONS SHOWN ON THIS PAGE ARE TYPICAL ONLY, AND APPLY TO STORAGE OF NUMEROUS SMALL LOTS. ADAPTATIONS MAY BE MADE AS NUMBER AND SIZES OF LOTS TO BE STORED IN MAGAZINE REQUIRE.
2. AN INSPECTION/INVENTORY AISLE NOT LESS THAN 18" WIDE MUST BE PROVIDED AT ONE SIDE OF EACH "BURIED" LOT.
3. GENERALLY, THE LARGEST LOT SHOULD BE STORED IN THE REAR OF THE MAGAZINE, HOWEVER, THE REAR AREA MAY BE USED TO STORE MORE THAN ONE LOT BY ERECTING STACKS SIMILAR TO THOSE SHOWN IN THE FRONTAL AREA. AN MHE AISLE WILL BE REQUIRED ON ONE SIDE OF THE MAGAZINE, AND EACH LOT MUST BE ACCESSIBLE FOR REMOVAL AND INSPECTION/INVENTORY IN ACCORDANCE WITH OTHER CRITERIA SPECIFIED IN THESE SPECIAL NOTES AND IN THE GENERAL NOTES ON PAGE 2.
4. A MIXED-LOT PALLET UNIT MAY HAVE FROM TWO LOTS PER PALLET UNIT UPWARDS TO AS MANY DIFFERENT LOTS AS BOXES WITHIN THAT UNIT, HOWEVER, LOTS WITHIN THE PALLET UNIT MUST HAVE THE SAME NATIONAL STOCK NUMBER AND CONDITION CODE.
5. EACH LOT WITHIN THE MAGAZINE MUST BE ACCESSIBLE FOR MOVEMENT BY MHE. PALLET UNITS OF A SINGLE-LOT OR MIXED-LOT PALLET UNITS ARE CONSIDERED "ACCESSIBLE" IF NO MORE THAN TWELVE (12) "LIFTS" OF ANOTHER LOT OR LOTS HAVE TO BE MADE TO GAIN ACCESS TO THE SINGLE-LOT OR MIXED-LOT UNITS. A "LIFT" MAY CONSIST OF ONE (1) OR TWO (2) PALLET UNITS, PROVIDING THE CAPACITY OF MHE PERMITS, AND SAFE HANDLING IS NOT JEOPARDIZED.
6. FOR STORAGE OF MULTIPLE LOTS, THE DISTANCE FROM THE SIDEWALL WILL BE BASED ON THE OVERHEAD CLEARANCE REQUIRED FOR MHE.
7. WHEN TWO LOTS ARE STORED ADJACENT TO EACH OTHER, THEY SHOULD BE SEPARATED BY AT LEAST 1" TO PROVIDE CLEARANCE FOR REMOVAL OF EITHER LOT.
8. AREAS ENCLOSED BY DOTTED LINES INDICATE LOCATIONS WHERE ADDITIONAL LOTS MAY BE STORED OR WHERE ADDITIONAL ITEMS MAY BE STORED, THAT ARE FROM THE LOT OR LOTS WHICH ARE DIRECTLY OR ALMOST DIRECTLY ACROSS THE CENTER AISLE ON THE OTHER SIDE OF THE MAGAZINE. COMPLIANCE WITH ALL OF THE MULTIPLE LOT CRITERIA AS SET FORTH ON THIS PAGE MUST BE OBSERVED. THE SIZE OF THE LOTS BEING STORED AND THE CRITERIA OF SPECIAL NOTE 5, RELATIVE TO "12 LIFTS", WILL BE MAJOR FACTORS IMPACTING ON THE NUMBER OF PALLET UNITS THAT CAN BE STORED IN AN "ADDITIONAL STORAGE LOCATION". MORE OR FEWER STACKS THAN SHOWN MAY BE STORED AT ANY ONE OF THE ADDITIONAL STORAGE LOCATIONS. A 11'-6" MHE OPERATING AREA HAS BEEN SPECIFIED FOR ACCESS TO EACH "ADDITIONAL LOCATION" BY FORKLIFT TRUCK, THIS OPERATING AREA IS BASED ON REQUIREMENTS OF FORKLIFT TRUCKS COMMONLY USED IN STORAGE MAGAZINES. THE MHE OPERATING AREA CAN BE ENLARGED AS REQUIRED TO SUIT AVAILABLE FORKLIFT TRUCKS, AND SHOULD BE MADE SMALLER IF AVAILABLE MHE PERMITS. A "CENTER AISLE" (SPACE BETWEEN STORAGE ON ONE SIDE OF A MAGAZINE AND AN "ADDITIONAL STORAGE LOCATION") IS TO BE AT LEAST 78 INCHES WIDE. AN AISLE SLIGHTLY WIDER THAN 78 INCHES WILL ENHANCE FORKLIFT TRUCK MOVEMENT WITHIN A MAGAZINE; HOWEVER, THIS AISLE SHOULD NOT BE MADE WIDER IF A LOSS IN STORAGE RESULTS.

(CONTINUED AT RIGHT)

TYPICAL MULTIPLE-LOT STORAGE IN IGLOO AND ARCH TYPE MAGAZINES

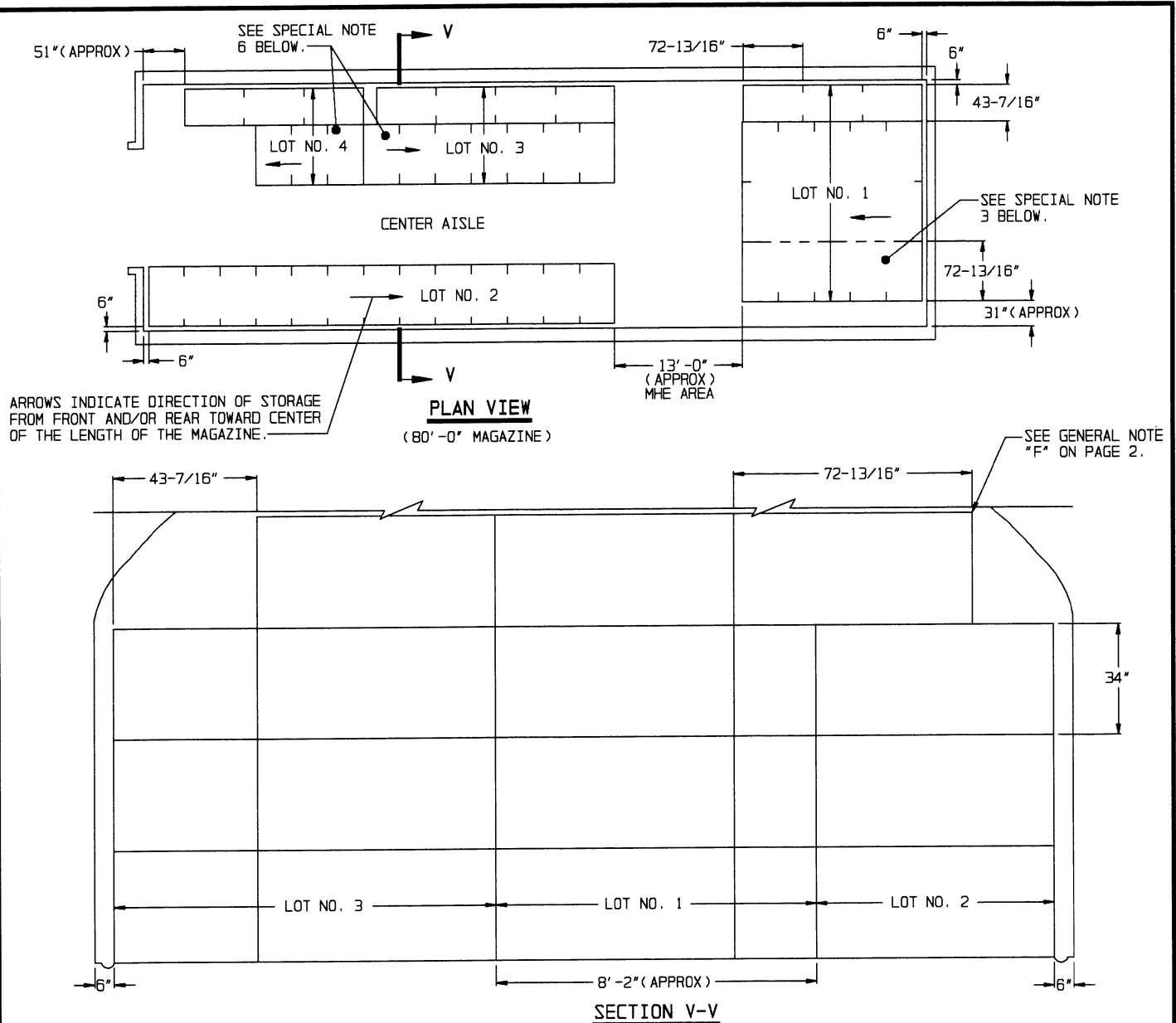

ARROWS INDICATE DIRECTION OF STORAGE FROM FRONT AND/OR REAR TOWARD CENTER OF THE LENGTH OF THE MAGAZINE.

PLAN VIEW
(80'-0" MAGAZINE)

SECTION V-V

SPECIAL NOTES:

1. THE STORAGE PLANS AND CONFIGURATIONS SHOWN ON THIS PAGE ARE TYPICAL ONLY, AND APPLY TO RELATIVELY LARGE LOTS. ADAPTATIONS MAY BE MADE AS NUMBER AND SIZES OF LOTS TO BE STORED IN MAGAZINE REQUIRE.
2. AN INSPECTION/INVENTORY AISLE MUST BE PROVIDED AT ONE SIDE OR END OF EACH LOT.
3. GENERALLY, THE LARGEST LOT SHOULD BE STORED IN THE REAR OF THE MAGAZINE, HOWEVER, THE REAR AREA MAY BE USED TO STORE MORE THAN ONE LOT BY ERECTING ROWS SIMILAR TO THOSE SHOWN IN THE FRONTAL AREA. A CENTER AISLE WILL NOT BE REQUIRED IN THE REAR AREA AS LONG AS EACH LOT IS ACCESSIBLE FOR REMOVAL AND INSPECTION/INVENTORY IN ACCORDANCE WITH OTHER CRITERIA SPECIFIED IN THESE SPECIAL NOTES AND IN THE GENERAL NOTES ON PAGE 2.
4. EACH LOT WITHIN THE MAGAZINE MUST BE ACCESSIBLE FOR MOVEMENT BY MHE. A SINGLE-LOT OF PALLET UNITS IS CONSIDERED "ACCESSIBLE" IF NO MORE THAN TWELVE (12) "LIFTS" OF ANOTHER LOT OR LOTS HAVE TO BE MADE TO GAIN ACCESS TO THAT LOT. A "LIFT" MAY CONSIST OF ONE (1) OR MORE PALLET UNITS, PROVIDING THE CAPACITY OF MHE PERMITS, AND SAFE HANDLING IS NOT JEOPARDIZED.
5. FOR STORAGE OF MULTIPLE LOTS, THE DISTANCE FROM THE SIDEWALL WILL BE BASED ON THE OVERHEAD CLEARANCE REQUIRED FOR MHE.

(CONTINUED AT RIGHT)

(SPECIAL NOTES CONTINUED)

6. WHEN TWO LOTS ARE STORED ADJACENT TO EACH OTHER, THEY SHOULD BE SEPARATED BY AT LEAST 1" TO PROVIDE CLEARANCE FOR REMOVAL OF EITHER LOT.
7. A 13'-0" MHE OPERATING AREA IS SHOWN. THE MHE OPERATING AREA CAN BE ENLARGED AS REQUIRED TO SUIT AVAILABLE FORKLIFT TRUCKS, AND SHOULD BE MADE SMALLER IF AVAILABLE MHE PERMITS. A "CENTER AISLE" (SPACE BETWEEN STORAGE ON EACH SIDE OF MAGAZINE) IS TO BE AT LEAST 78" WIDE. A SLIGHTLY WIDER AISLE WILL ENHANCE FORKLIFT TRUCK MOVEMENT WITHIN A MAGAZINE; HOWEVER, THIS AISLE SHOULD NOT BE MADE WIDER IF A LOSS OF STORAGE RESULTS.

MIXED LOT PALLET UNITS.
SEE SPECIAL NOTE 4 BELOW.

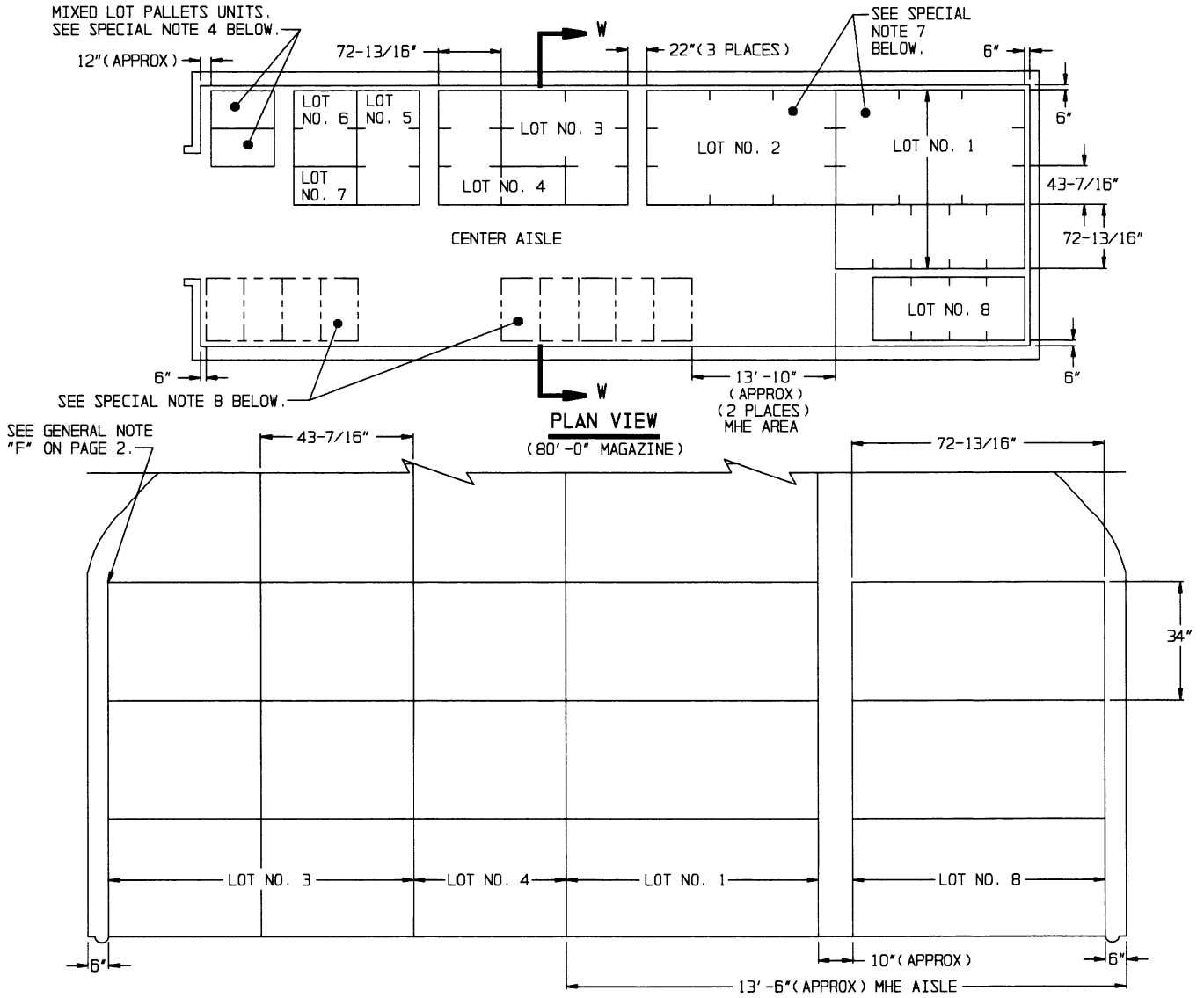

SPECIAL NOTES:

1. THE STORAGE PLANS AND CONFIGURATIONS SHOWN ON THIS PAGE ARE TYPICAL ONLY, AND APPLY TO STORAGE OF NUMEROUS SMALL LOTS. ADAPTATIONS MAY BE MADE AS NUMBER AND SIZES OF LOTS TO BE STORED IN MAGAZINE REQUIRE.
2. AN INSPECTION/INVENTORY AISLE NOT LESS THAN 18" WIDE MUST BE PROVIDED AT ONE SIDE OF EACH "BURIED" LOT.
3. GENERALLY, THE LARGEST LOT SHOULD BE STORED IN THE REAR OF THE MAGAZINE, HOWEVER, THE REAR AREA MAY BE USED TO STORE MORE THAN ONE LOT BY ERECTING STACKS SIMILAR TO THOSE SHOWN IN THE FRONTAL AREA. AN MHE AISLE WILL BE REQUIRED ON ONE SIDE OF THE MAGAZINE, AND EACH LOT MUST BE ACCESSIBLE FOR REMOVAL AND INSPECTION/INVENTORY IN ACCORDANCE WITH OTHER CRITERIA SPECIFIED IN THESE SPECIAL NOTES AND IN THE GENERAL NOTES ON PAGE 2.
4. A MIXED-LOT PALLET UNIT MAY HAVE FROM TWO LOTS PER PALLET UPWARD TO AS MANY DIFFERENT LOTS AS BOXES WITHIN THAT UNIT, HOWEVER, ALL LOTS WITHIN THE PALLET UNIT MUST HAVE THE SAME NATIONAL STOCK NUMBER AND CONDITION CODE.
5. EACH LOT WITHIN THE MAGAZINE MUST BE ACCESSIBLE FOR MOVEMENT BY MHE. PALLET UNITS OF A SINGLE-LOT OR MIXED-LOT PALLET UNITS ARE CONSIDERED "ACCESSIBLE" IF NO MORE THAN TWELVE (12) "LIFTS" OF ANOTHER LOT OR LOTS HAVE TO BE MADE TO GAIN ACCESS TO THE SINGLE-LOT OR MIXED-LOT UNITS. A "LIFT" MAY CONSIST OF ONE (1) OR TWO (2) PALLET UNITS, PROVIDING THE CAPACITY OF MHE PERMITS, AND SAFE HANDLING IS NOT JEOPARDIZED.

(SPECIAL NOTES CONTINUED)

6. FOR STORAGE OF MULTIPLE LOTS, THE DISTANCE FROM THE SIDEWALL WILL BE BASED ON THE OVERHEAD CLEARANCE REQUIRED FOR MHE.
7. WHEN TWO LOTS ARE STORED ADJACENT TO EACH OTHER, THEY SHOULD BE SEPARATED BY AT LEAST 1" TO PROVIDE CLEARANCE FOR REMOVAL OF EITHER LOT.
8. AREAS ENCLOSED BY DOTTED LINES INDICATE LOCATIONS WHERE ADDITIONAL LOTS MAY BE STORED OR WHERE ADDITIONAL ITEMS MAY BE STORED, THAT ARE FROM THE LOT OR LOTS WHICH ARE DIRECTLY OR ALMOST DIRECTLY ACROSS THE CENTER AISLE ON THE OTHER SIDE OF THE MAGAZINE. COMPLIANCE WITH ALL OF THE MULTIPLE LOT CRITERIA AS SET FORTH ON THIS PAGE MUST BE OBSERVED. THE SIZE OF THE LOTS BEING STORED AND THE CRITERIA OF SPECIAL NOTE 5, RELATIVE TO "12 LIFTS", WILL BE MAJOR FACTORS IMPACTING ON THE NUMBER OF PALLET UNITS THAT CAN BE STORED IN AN "ADDITIONAL STORAGE LOCATION". MORE OR FEWER STACKS THAN SHOWN MAY BE STORED AT ANY ONE OF THE ADDITIONAL STORAGE LOCATIONS. A 13'-10" MHE OPERATING AREA HAS BEEN SPECIFIED FOR ACCESS TO EACH "ADDITIONAL LOCATION" BY FORKLIFT TRUCK. THIS OPERATING AREA IS BASED ON REQUIREMENTS OF FORKLIFT TRUCKS COMMONLY USED IN STORAGE MAGAZINES. THE MHE OPERATING AREA CAN BE ENLARGED AS REQUIRED TO SUIT AVAILABLE FORKLIFT TRUCKS, AND SHOULD BE MADE SMALLER IF AVAILABLE MHE PERMITS. A "CENTER AISLE" (SPACE BETWEEN STORAGE ON ONE SIDE OF A MAGAZINE AND AN "ADDITIONAL STORAGE LOCATION") IS TO BE AT LEAST 78 INCHES WIDE. AN AISLE SLIGHTLY WIDER THAN 78 INCHES WILL ENHANCE FORKLIFT TRUCK MOVEMENT WITHIN A MAGAZINE; HOWEVER, THIS AISLE SHOULD NOT BE MADE WIDER IF A LOSS IN STORAGE RESULTS.

(CONTINUED AT RIGHT)

TYPICAL MULTIPLE-LOT STORAGE IN STRADLEY MAGAZINE

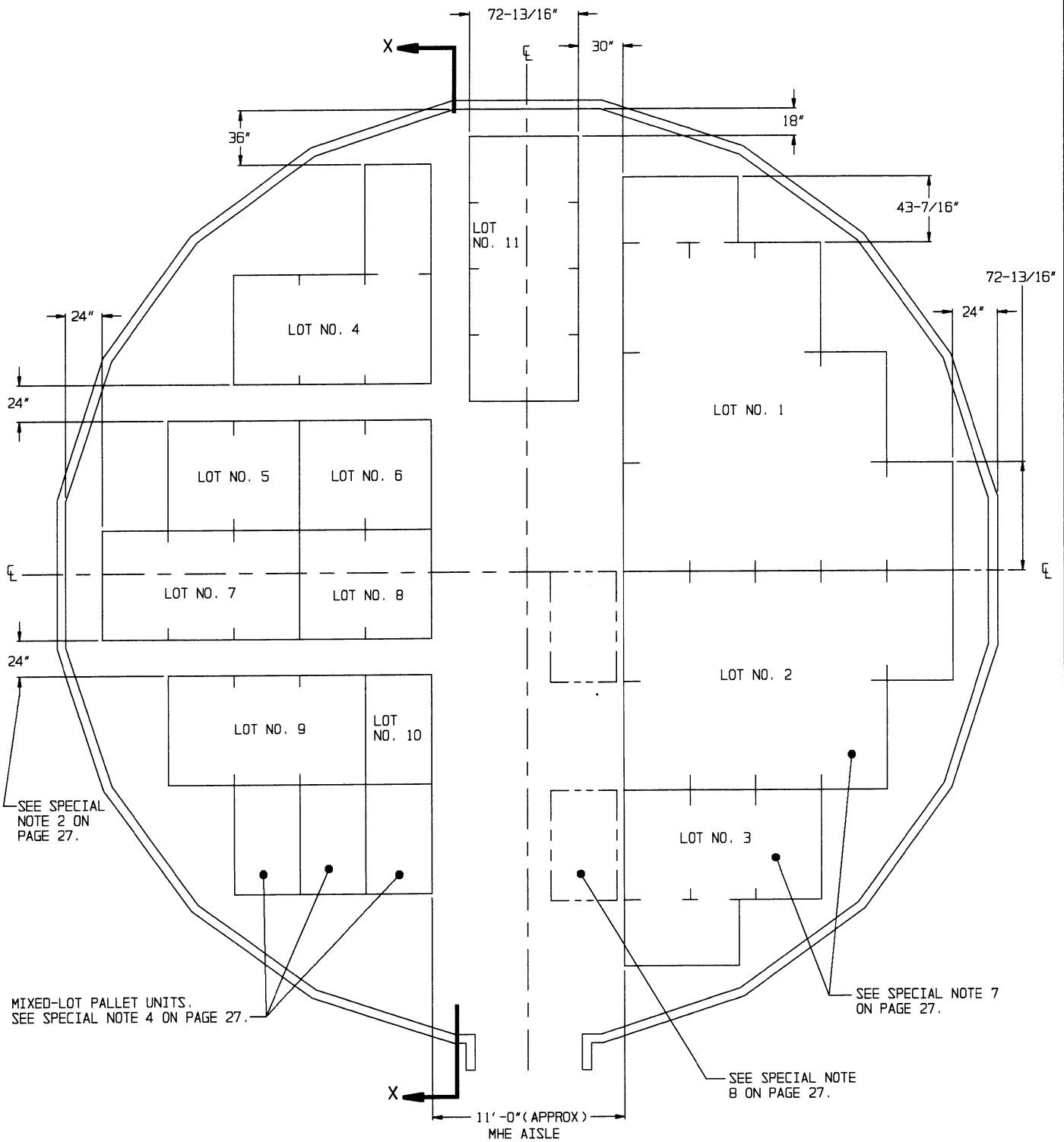

PLAN VIEW
(52'-0" DIA MAGAZINE)

TYPICAL MULTIPLE-LOT STORAGE IN CORBETTA MAGAZINE

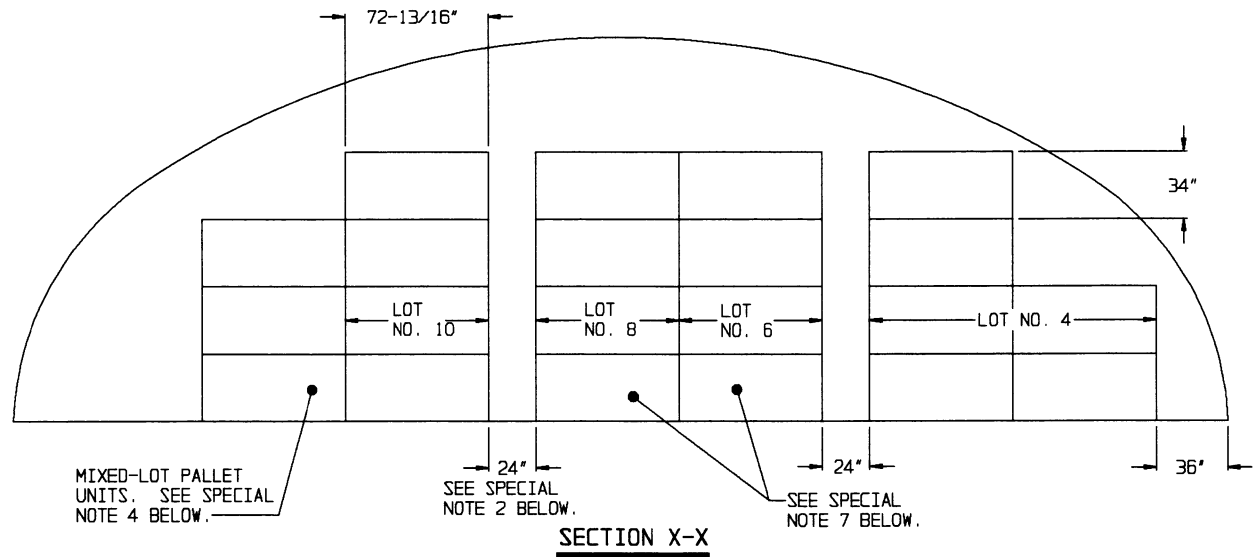

SPECIAL NOTES:

1. THE STORAGE PLANS AND CONFIGURATIONS SHOWN ON THIS PAGE AND ON PAGE 26 ARE TYPICAL ONLY. ADAPTATIONS MAY BE MADE AS NUMBER AND SIZES OF LOTS TO BE STORED IN MAGAZINE REQUIRE.
2. AN INSPECTION/INVENTORY AISLE NOT LESS THAN 18" WIDE MUST BE PROVIDED AT ONE SIDE OF EACH "BURIED" LOT.
3. GENERALLY, THE LARGEST LOT SHOULD BE STORED ON ONE SIDE OF THE MAGAZINE, HOWEVER, BOTH SIDES MAY BE USED TO STORE MORE THAN ONE LOT BY ERECTING STACKS SIMILAR TO THOSE SHOWN ON THE LEFT SIDE. AN MHE AISLE WILL BE REQUIRED IN THE CENTER OF THE MAGAZINE, AND EACH LOT MUST BE ACCESSIBLE FOR REMOVAL AND INSPECTION/INVENTORY IN ACCORDANCE WITH OTHER CRITERIA SPECIFIED IN THESE SPECIAL NOTES AND IN THE GENERAL NOTES ON PAGE 2.
4. A MIXED-LOT PALLET UNIT MAY HAVE FROM TWO LOTS PER PALLET UNIT UPWARDS TO AS MANY DIFFERENT LOTS AS BOXES WITHIN THAT UNIT, HOWEVER, ALL LOTS WITHIN THE PALLET UNIT MUST HAVE THE SAME NATIONAL STOCK NUMBER AND CONDITION CODE.
5. EACH LOT WITHIN THE MAGAZINE MUST BE ACCESSIBLE FOR MOVEMENT BY MHE. PALLET UNITS OF A SINGLE-LOT OR MIXED-LOT PALLET UNITS ARE CONSIDERED "ACCESSIBLE" IF NO MORE THAN TWELVE (12) "LIFTS" OF ANOTHER LOT OR LOTS HAVE TO BE MADE TO GAIN ACCESS TO THE SINGLE-LOT OR MIXED-LOT UNITS. A "LIFT" MAY CONSIST OF ONE (1) OR TWO (2) PALLET UNITS, PROVIDING THE CAPACITY OF MHE PERMITS, AND SAFE HANDLING IS NOT JEOPARDIZED.
6. FOR STORAGE OF MULTIPLE LOTS, THE DISTANCE FROM THE WALL WILL BE BASED ON THE OVERHEAD CLEARANCE REQUIRED FOR MHE.
7. WHEN TWO LOTS ARE STORED ADJACENT TO EACH OTHER, THEY SHOULD BE SEPARATED BY AT LEAST 1" TO PROVIDE CLEARANCE FOR REMOVAL OF EITHER LOT.
8. AREAS ENCLOSED BY DOTTED LINES INDICATE LOCATIONS WHERE ADDITIONAL LOTS OR ITEMS MAY BE STORED, THAT ARE FROM THE LOT OR LOTS ADJACENT TO THE MHE AISLE. COMPLIANCE WITH ALL OF THE MULTIPLE LOT CRITERIA AS SET FORTH ON THIS PAGE MUST BE OBSERVED. THE SIZE OF THE LOTS BEING STORED AND THE CRITERIA OF SPECIAL NOTE 5, RELATIVE TO "12 LIFTS", WILL BE MAJOR FACTORS IMPACTING ON THE NUMBER OF PALLET UNITS THAT CAN BE STORED IN AN "ADDITIONAL STORAGE LOCATION". MORE OR FEWER STACKS THAN SHOWN MAY BE STORED AT ANY ONE OF THE ADDITIONAL STORAGE LOCATIONS. A "CENTER AISLE" ("SPACE BETWEEN STORAGE ON ONE SIDE OF THE MAGAZINE AND AN "ADDITIONAL STORAGE LOCATION") IS TO BE AT LEAST 78 INCHES WIDE. AN AISLE SLIGHTLY WIDER THAN 78 INCHES WILL ENHANCE FORKLIFT TRUCK MOVEMENT WITHIN A MAGAZINE; HOWEVER, THIS AISLE SHOULD NOT BE MADE WIDER IF A LOSS IN STORAGE RESULTS.

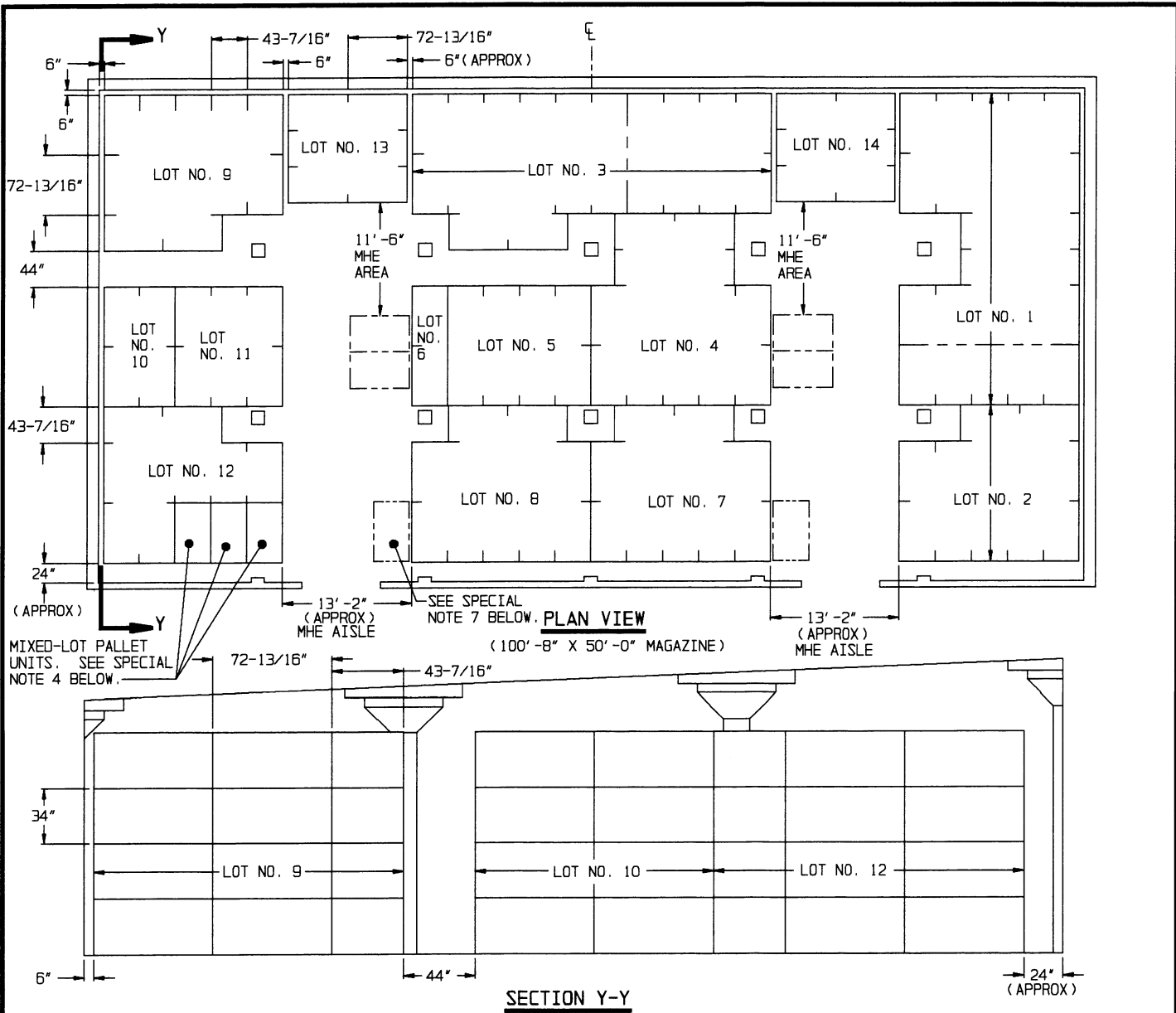

SPECIAL NOTES:

1. THE STORAGE PLANS AND CONFIGURATIONS SHOWN ON THIS PAGE ARE TYPICAL ONLY. ADAPTATIONS MAY BE MADE AS NUMBER AND SIZES OF LOTS TO BE STORED IN MAGAZINE REQUIRE.
2. AN INSPECTION/INVENTORY AISLE NOT LESS THAN 18" WIDE MUST BE PROVIDED AT ONE SIDE OF EACH "BURIED LOT".
3. GENERALLY, THE LARGEST LOT SHOULD BE STORED IN THE REAR OR ON ONE SIDE OF THE MAGAZINE, HOWEVER, THESE AREAS MAY BE USED TO STORE MORE THAN ONE LOT BY ERECTING ROWS SIMILAR TO THOSE SHOWN IN THE SMALLER SIZED LOTS, OR AS TYPICALLY SHOWN BY DOTTED LINES. EACH ADDITIONAL LOT MUST BE ACCESSIBLE FOR REMOVAL AND INSPECTION/INVENTORY IN ACCORDANCE WITH OTHER CRITERIA SPECIFIED IN THESE SPECIAL NOTES AND IN THE GENERAL NOTES ON PAGE 2.
4. A MIXED-LOT PALLET UNIT MAY HAVE FROM TWO LOTS PER PALLET UNIT UPWARDS TO AS MANY DIFFERENT LOTS AS BOXES WITHIN THAT UNIT, HOWEVER, ALL LOTS WITHIN THE PALLET UNIT MUST HAVE THE SAME NATIONAL STOCK NUMBER AND CONDITION CODE.
5. EACH LOT WITHIN THE MAGAZINE MUST BE ACCESSIBLE FOR MOVEMENT BY MHE. PALLET UNITS OF A SINGLE-LOT OR MIXED-LOT PALLET UNITS ARE CONSIDERED "ACCESSIBLE" IF NO MORE THAN TWENTY-FOUR (24) "LIFTS" OF ANOTHER LOT OR LOTS HAVE TO BE MADE TO GAIN ACCESS TO THE SINGLE-LOT OR MIXED-LOT UNITS. A "LIFT MAY CONSIST OF ONE (1) OR TWO (2) PALLET UNITS, PROVIDING THE CAPACITY OF MHE PERMITS, AND SAFE HANDLING IS NOT JEOPARDIZED.

(SPECIAL NOTES CONTINUED)

6. WHEN TWO LOTS ARE STORED ADJACENT TO EACH OTHER, THEY SHOULD BE SEPARATED BY AT LEAST 1" TO PROVIDE CLEARANCE FOR REMOVAL OF EITHER LOT.
7. AREAS ENCLOSED BY DOTTED LINES INDICATE LOCATIONS WHERE ADDITIONAL LOTS MAY BE STORED OR WHERE ADDITIONAL ITEMS MAY BE STORED, THAT ARE FROM A LOT OR LOTS ADJACENT TO THE MHE AISLE. COMPLIANCE WITH ALL OF THE MULTIPLE-LOT CRITERIA, AS SET FORTH ON THIS PAGE, MUST BE OBSERVED. THE SIZE OF THE LOTS BEING STORED AND THE CRITERIA OF SPECIAL NOTE 5, RELATIVE TO "24 LIFTS", WILL BE MAJOR FACTORS IMPACTING ON THE NUMBER OF PALLET UNITS THAT CAN BE STORED IN AN "ADDITIONAL STORAGE LOCATION". MORE OR FEWER STACKS THAN SHOWN MAY BE STORED AT ANY ONE OF THE ADDITIONAL STORAGE LOCATIONS. A 11'-6" MHE OPERATING AREA HAS BEEN SPECIFIED FOR ACCESS TO EACH "ADDITIONAL LOCATION" BY FORKLIFT TRUCK. THIS OPERATING AREA IS BASED ON REQUIREMENTS OF FORKLIFT TRUCKS COMMONLY USED IN STORAGE MAGAZINES. THE MHE OPERATING AREA CAN BE ENLARGED AS REQUIRED TO SUIT AVAILABLE FORKLIFT TRUCKS, AND SHOULD BE MADE SMALLER IF AVAILABLE MHE PERMITS. AN MHE AISLE (SPACE BETWEEN STORED PALLET UNITS) IS TO BE AT LEAST 78 INCHES WIDE. AN AISLE SLIGHTLY WIDER THAN 78 INCHES WILL ENHANCE FORKLIFT TRUCK MOVEMENT WITHIN A MAGAZINE; HOWEVER, THIS AISLE SHOULD NOT BE MADE WIDER IF A LOSS IN STORAGE RESULTS.

(CONTINUED AT RIGHT)