

LOADING AND BRACING[⊕] IN SIDE OPENING ISO CONTAINERS OF 2.75" HYDRA ROCKETS IN M643 CONTAINERS, ON METAL PALLETS

INDEX

ITEM	PAGE(S)
TYPICAL LOADING PROCEDURES	2
GENERAL NOTES AND MATERIAL SPECIFICATIONS	3
PALLET UNIT DETAIL	4
DETAILS	4-7
LESS-THAN-FULL-LOAD PROCEDURE	8

DISTRIBUTION STATEMENT A:

APPROVED FOR PUBLIC RELEASE
DISTRIBUTION IS UNLIMITED.

⊕ THE PROCEDURES SHOWN HEREIN ARE APPLICABLE TO LOADS THAT ARE TO BE SHIPPED BY TRAILER/CONTAINER-ON-FLATCAR (T/COFC) RAIL, MOTOR, OR WATER CARRIERS.

U.S. ARMY MATERIEL COMMAND DRAWING

<p>APPROVED, U.S. ARMY JOINT MUNITIONS COMMAND</p> <p>RUS.ALLEN.J .1230354282</p> <p><small>Digitally signed by RUS.ALLEN.J.1230354282 DN: cn=US, o=U.S. Government, ou=DoD, ou=PKI, ou=USA, cn=RUS.ALLEN.J.1230354282 Date: 2016.01.05 15:01:03 -06'00'</small></p>		<p>CAUTION: VERIFY PRIOR TO USE AT HTTPS://MHP.REDSTONE.ARMY.MIL THAT THIS IS THE MOST CURRENT VERSION OF THIS DOCUMENT. THIS IS PAGE 1 OF 8.</p>			
<p>APPROVED BY ORDER OF COMMANDING GENERAL, U.S. ARMY MATERIEL COMMAND</p> <p>SHIMP.UPTON .R.1231257183</p> <p><small>Digitally signed by SHIMP.UPTON.R.1231257183 DN: cn=US, o=U.S. Government, ou=DoD, ou=PKI, ou=USA, cn=SHIMP.UPTON.R.1231257183 Date: 2016.01.11 10:13:16 -06'00'</small></p> <p>U.S. ARMY DEFENSE AMMUNITION CENTER</p>		<p>DO NOT SCALE</p> <p>DESIGN ENGINEER: BASIC: MADELINE BANKS</p> <p>REV.</p>		<p>FEBRUARY 2016</p>	
<p>ENGINEERING DIVISON</p> <p>TEST ENGINEER</p> <p>TEST REPORT: NA</p> <p>EXPLOSIVE SAFETY DIRECTORATE</p>		<p>FIEFFER.LAURA .A.1230375727</p> <p>FELICIANO.ADI N.1259200373</p> <p>TIRONE.JOSEPH.A NDREW.1026683749</p>		<p><small>Digitally signed by FIEFFER.LAURA.A.1230375727 DN: cn=US, o=U.S. Government, ou=DoD, ou=PKI, ou=USA, cn=FIEFFER.LAURA.A.1230375727 Date: 2015.10.28 07:01:48 -06'00'</small></p> <p><small>Digitally signed by FELICIANO.ADI.1259200373 DN: cn=US, o=U.S. Government, ou=DoD, ou=PKI, ou=USA, cn=FELICIANO.ADI.1259200373 Date: 2015.11.05 08:35:00 -06'00'</small></p> <p><small>Digitally signed by TIRONE.JOSEPH.ANDREW.1026683749 DN: cn=US, o=U.S. Government, ou=DoD, ou=PKI, ou=USA, cn=TIRONE.JOSEPH.ANDREW.1026683749 Date: 2015.12.03 17:52:00 -06'00'</small></p>	
		CLASS	DIVISION	DRAWING	FILE
		19	48	4272/62	15PM1016

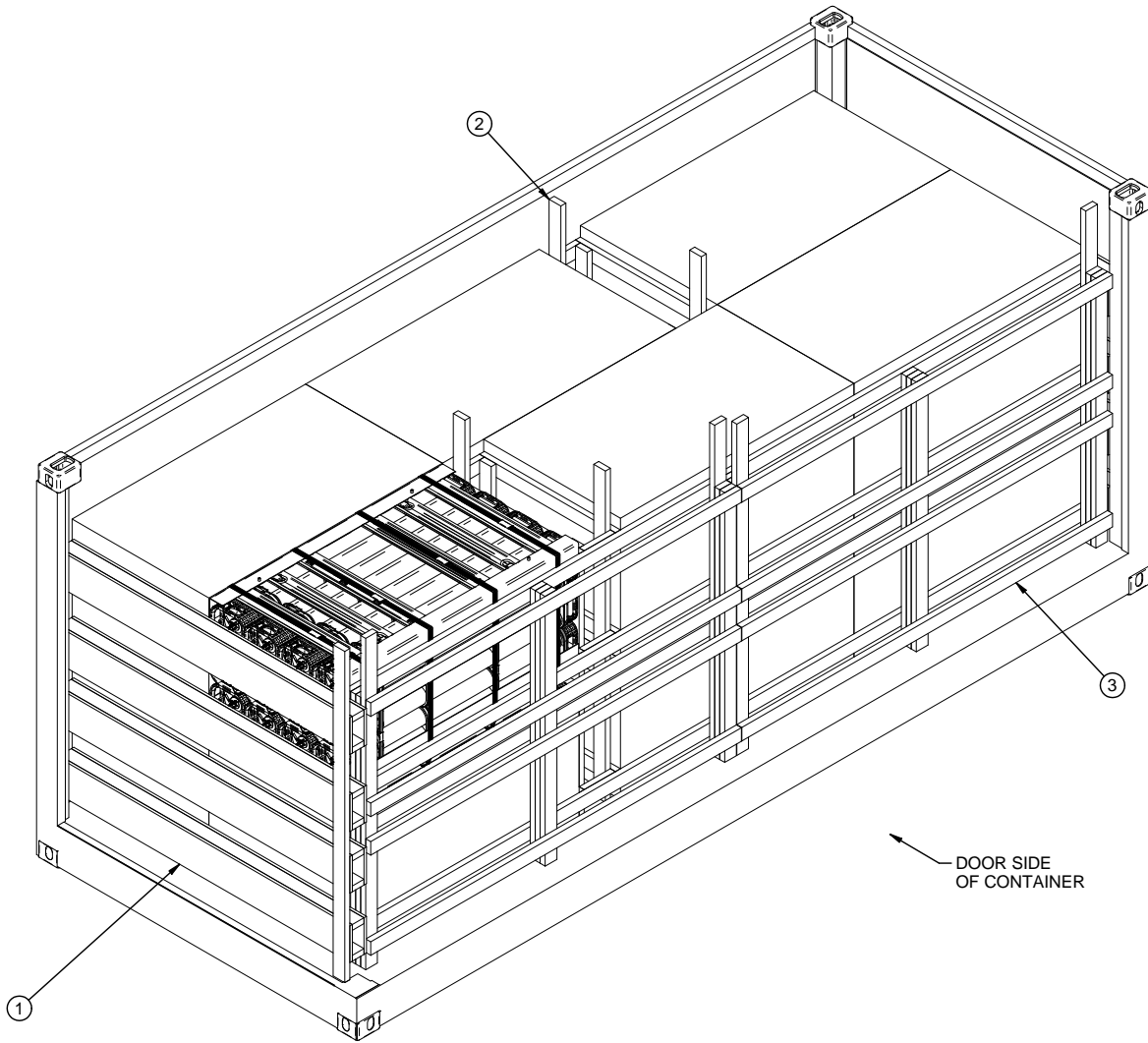

ISOMETRIC VIEW

KEY NUMBERS

- ① END BLOCKING ASSEMBLY (2 REQD). SEE THE DETAIL ON PAGE 5.
- ② CRIB FILL ASSEMBLY (2 REQD). SEE THE DETAIL ON PAGE 6.
- ③ SIDE FILL ASSEMBLY (2 REQD). SEE THE DETAIL ON PAGE 6.

BILL OF MATERIAL

LUMBER	LINEAR FEET	BOARD FEET
2" X 4"	516	344
NAI LS	NO. REQD	POUNDS
6d (2")	320	2
10d (3")	328	5-1/4
PLYWOOD, 3/4" - 90.78 SQ FT REQD -		187.23 LBS

LOAD AS SHOWN

ITEM	QUANTITY	WEIGHT (APPROX)
PALLET UNIT	12	28,104 LBS
DUNNAGE		882 LBS
CONTAINER		6,050 LBS
TOTAL WEIGHT		35,036 LBS (APPROX)

GENERAL NOTES

- A. THIS DOCUMENT HAS BEEN PREPARED AND ISSUED IN ACCORDANCE WITH AR 740-1 AND AUGMENTS TM 743-200-1 (CHAPTER 5).
- B. THE SPECIFIED OUTLOADING PROCEDURES ARE APPLICABLE TO LOADS OF 2.75" HYDRA ROCKETS IN M643 CONTAINERS, ON METAL PALLETS. SUBSEQUENT REFERENCE TO PALLET UNIT HEREIN MEANS THE PALLET UNIT WITH AMMUNITION ITEMS. SEE PAGE 4 AND AMC DRAWING 19-48-4231/62-20PM1006 FOR DETAILS OF THE PALLET UNIT. **CAUTION:** REGARDLESS OF THE QUANTITY OF PALLET UNITS TO BE SHIPPED, THE "MAXIMUM GROSS WEIGHT" OF THE SIDE OPENING ISO CONTAINER MUST NOT BE EXCEEDED.
- C. THE LOAD AS SHOWN IS BASED ON A 6,050 POUND 20' LONG BY 8' WIDE BY 8'-6" HIGH SIDE OPENING ISO CONTAINER WITH INSIDE DIMENSIONS OF 19'-6-1/4" LONG BY 90" WIDE BY 89" HIGH, WITH A MAXIMUM GROSS WEIGHT OF 52,910 POUNDS. OLDER/OTHER CONTAINERS MAY HAVE DIFFERENT INSIDE MEASUREMENTS, VERIFY INSIDE CONTAINER DIMENSIONS PRIOR TO FABRICATING DUNNAGE. THE LOAD IS DESIGNED FOR TRAILER/CONTAINER-ON-FLATCAR (T/COFC) SHIPMENT, HOWEVER, THE LOAD AS DESIGNED CAN ALSO BE MOVED BY OTHER SURFACE MODES OF TRANSPORT. **NOTICE:** OTHER CONTAINERS OF THE SAME DESIGN CONFIGURATION CAN BE USED.
- D. WHEN LOADING PALLET UNITS, THEY ARE TO BE POSITIONED SO AS TO ACHIEVE A TIGHT LOAD (TIGHT AGAINST THE DUNNAGE ASSEMBLIES). THE UNBLOCKED SPACE ACROSS THE WIDTH OF A LOAD BAY IS NOT TO EXCEED 1-1/2". EXCESSIVE SLACK CAN BE ELIMINATED FROM A LOAD BY LAMINATING ADDITIONAL PIECES OF APPROPRIATE THICKNESS TO THE HORIZONTAL PIECES ON THE SIDE FILL ASSEMBLIES. NAIL EACH ADDITIONAL PIECE W/1 APPROPRIATELY SIZED NAIL EVERY 12". ADDITIONALLY, THE THICKNESS AND/OR QUANTITY OF THE VERTICAL OR HORIZONTAL PIECES IN THE SIDE FILL ASSEMBLIES MAY BE ADJUSTED AS REQUIRED TO FACILITATE VARIANCE IN THE SIZE OF THE PALLET UNIT. THE LOADS MUST BE AS TIGHT AS POSSIBLE LONGITUDINALLY, BUT THE VOID MUST NOT EXCEED 3/4" OVERALL. EXCESSIVE SLACK CAN BE ELIMINATED FROM A LOAD BY LAMINATING ADDITIONAL PIECES OF APPROPRIATE THICKNESS TO THE LONGITUDINAL PIECES ON THE CRIB FILL ASSEMBLIES.
- E. A STAGGERED NAILING PATTERN WILL BE USED WHENEVER POSSIBLE WHEN NAILS ARE DRIVEN INTO JOINTS OF DUNNAGE ASSEMBLIES OR WHEN LAMINATING DUNNAGE. ADDITIONALLY, THE NAILING PATTERN FOR AN UPPER PIECE OF LAMINATED DUNNAGE WILL BE ADJUSTED AS REQUIRED SO THAT A NAIL FOR THAT PIECE WILL NOT BE DRIVEN THROUGH ONTO OR RIGHT BESIDE A NAIL IN A LOWER PIECE.
- F. **CAUTION:** DO NOT NAIL DUNNAGE MATERIAL TO THE CONTAINER WALLS OR FLOOR. ALL NAILING WILL BE WITHIN THE DUNNAGE.
- G. IN SOME CONTAINERS THERE IS A SLOT AT THE CORNERS OF THE ENDWALL. PIECES OF DUNNAGE MATERIAL MUST BE LAMINATED TO THE BUFFER PIECES ON THE END BLOCKING ASSEMBLY TO PROVIDE A FLAT SURFACE FOR THE BUFFER PIECES. A PIECE OF 2" X 4", 2" X 3" OR A SPECIAL WIDTH PIECE CUT-TO-FIT CAN BE USED. THIS FILL PIECE WILL BE NAILED WITH ONE APPROPRIATELY SIZED NAIL EVERY 12". NOTE THAT SOME CONTAINERS ARE EQUIPPED WITH "TIE-BARS" IN THE CORNER SLOT, WHICH PRECLUDE THE USE OF A FULL HEIGHT FILL PIECE. WHEN "TIE-BARS" ARE PRESENT, THE FILL PIECE MUST BE INSTALLED IN SEGMENTS DESIGNED TO FIT BETWEEN THE "TIE-BARS" VERTICALLY. THE FILL PIECE(S) IS NOT REQUIRED WHEN THE CORNER PORTIONS OF THE CONTAINER FORWARD WALL ARE SMOOTH AND FLAT. DO NOT ALLOW ANY DUNNAGE ASSEMBLY TO CONTACT THE CONTAINER ENDWALLS, ONLY THE CORNER POSTS OF THE CONTAINER SHOULD BE USED FOR FORWARD LONGITUDINAL BLOCKING.
- H. WHETHER A CONTAINER IS FULL OR IS LOADED WITH A REDUCED QUANTITY OF LADING UNITS, THE LENGTHWISE CENTER OF GRAVITY OF THE LOAD MUST BE WITHIN 12", IN EITHER DIRECTION, OF THE MID-POINT OF THE CONTAINER.
- J. PORTIONS OF THE CONTAINER DEPICTED WITHIN THIS DRAWING, SUCH AS THE SIDEWALL, HAVE NOT BEEN SHOWN IN THE LOAD VIEWS FOR CLARITY PURPOSES.
- K. **MAXIMUM LOAD WEIGHT CRITERIA:**

THE MAXIMUM LOAD WEIGHTS ARE CONTROLLED BY EQUIPMENT CAPABILITY FACTORS. ALTHOUGH THE HEAVIEST MAXIMUM LOADS ARE DELINEATED IN THE LOAD VIEWS, PROVISIONS ARE INCLUDED WITHIN THIS DRAWING SO THAT THE BASIC LOADS CAN BE ADJUSTED TO SATISFY A LESSER QUANTITY OF LADING UNITS. DEPENDING ON TRANSPORTATION ROUTING, IT MAY BE NECESSARY TO REDUCE THE LOAD WEIGHT TO SATISFY "WEIGHT LAWS" OF CERTAIN STATES. ALSO, IT MAY BE NECESSARY TO REDUCE THE LOAD WEIGHT TO SATISFY OTHER WEIGHT RESTRICTIONS IMPOSED ON THE INTERMODAL CONTAINER SYSTEM.

(CONTINUED AT RIGHT)

(GENERAL NOTES CONTINUED)

- L. REQUIREMENTS CITED WITHIN THE ASSOCIATION OF AMERICAN RAILROADS (AAR) INTERMODAL LOADING GUIDE APPLY WHEN THE SHIPMENT MOVES BY TRAILER/CONTAINER-ON-FLATCAR (T/COFC). SPECIAL T/COFC NOTES FOLLOW:
1. A LOADED CONTAINER MUST BE ON A CHASSIS EQUIPPED WITH TWO BOGIE ASSEMBLIES WHEN BEING MOVED IN TOFC SERVICE.
 2. THE LOAD LIMIT OF A T/COFC RAILCAR MUST NOT BE EXCEEDED, NOR WILL A CAR BE LOADED SO THAT THE TRUCK UNDER ONE END OF THE CAR CARRIES MORE THAN ONE-HALF OF THE LOAD LIMIT FOR THAT CAR.
- M. DURING INTRASTATE AND/OR INTERSTATE MOVES BY MOTOR CARRIER, A PROPER CHASSIS OR MODIFIED FLATBED TRAILER MUST BE USED TO PRECLUDE VIOLATION OF ONE OR MORE "WEIGHT LAWS" APPLICABLE TO THE STATE OR STATES INVOLVED.
- N. CONVERSION TO METRIC EQUIVALENTS: DIMENSIONS WITHIN THIS DOCUMENT ARE EXPRESSED IN INCHES AND WEIGHTS ARE EXPRESSED IN POUNDS. WHEN NECESSARY, THE METRIC EQUIVALENTS MAY BE COMPUTED ON THE BASIS OF ONE INCH EQUALS 25.4MM AND ONE POUND EQUALS 0.454 KG.
- O. THE QUANTITY OF PALLET UNITS SHOWN IN THE LOAD ON PAGE 2 MAY BE REDUCED FOR SHIPMENT, IF DESIRED. SEE THE "LESS-THAN-FULL LOAD PROCEDURE" ON PAGE 8.
1. IF A LOAD IS REDUCED BY ONLY A SMALL AMOUNT (ONE, TWO OR THREE LADING UNITS), LADING UNITS NORMALLY MAY BE ELIMINATED FROM THE CENTER OF THE LOAD.
 2. IF A LOAD IS REDUCED BY A LARGE AMOUNT (MORE THAN THREE LADING UNITS), LADING UNITS SHOULD BE ELIMINATED AS REQUIRED AND THE VOID IN THE LONGITUDINAL CENTER OF THE CONTAINER SHIFTED FORE OR AFT, AS NECESSARY, TO ACHIEVE A SYMMETRICAL WEIGHT DISTRIBUTION. THE DEPICTED PROCEDURES WILL BE FOLLOWED AS CLOSELY AS POSSIBLE, MAKING ONLY THOSE ADJUSTMENTS TO THE DUNNAGE WHICH ARE REQUIRED TO ACCOMMODATE THE NUMBER OF UNITS TO BE SHIPPED.
- P. DUNNAGE LUMBER SPECIFIED IS OF NOMINAL SIZE. FOR EXAMPLE, 1" X 4" MATERIAL IS ACTUALLY 3/4" THICK BY 3-1/2" WIDE AND 2" X 6" MATERIAL IS ACTUALLY 1-1/2" THICK BY 5-1/2" WIDE.
- Q. LOAD-BLOCKING STRUTS WHICH ARE 48" OR LONGER MUST BE STIFFENED BY THE APPLICATION OF HORIZONTAL AND VERTICAL STRUT BRACING AS SHOWN IN THE "LESS-THAN-FULL LOAD PROCEDURE" DETAIL ON PAGE 8. BRACING IS NOT REQUIRED IF THE STRUTS FOR THE LOAD BEING SHIPPED ARE SHORTER THAN 48". THE LENGTH OF THE LOAD-BLOCKING STRUTS SHOULD BE KEPT AS SHORT AS POSSIBLE (APPROX 18" MINIMUM), BUT IN THE EVENT IT IS NECESSARY TO USE STRUTS WHICH ARE 8'-0" OR MORE IN LENGTH, IT WILL BE NECESSARY TO APPLY AN ADDITIONAL SET OF HORIZONTAL AND VERTICAL STRUT BRACING PIECES. STRUT BRACING SHOULD BE APPLIED SO AS TO PROVIDE NEARLY EQUAL SPACES BETWEEN THE BRACING PIECES AND THE CENTER GATES AND/OR BETWEEN ADJACENT STRUT BRACING PIECES. NOTE THAT HORIZONTAL STRUT BRACING PIECES FOR THE UPPER LEVEL OF STRUTS FOR ALL BUT THE UPPERMOST TIER OF A LOAD MAY BE DIFFICULT TO APPLY TO THE TOP SURFACES OF THE STRUT AS DEPICTED. STRUT BRACING WILL BE EQUALLY EFFECTIVE IF APPLIED TO THE UNDER SIDE OF THOSE STRUTS.
- R. ANTI-CHAFING MATERIAL MAY BE INSTALLED AT POINTS OF CONTACT BETWEEN PALLET UNITS, BETWEEN PALLET UNITS AND THE SIDE OPENING CONTAINER, AND BETWEEN PALLET UNITS AND STEEL STRAPPING, IF DESIRED, TO PREVENT CHAFING DAMAGE TO CONTAINER PAINT AND MARKINGS.

MATERIAL SPECIFICATIONS

<u>LUMBER</u>	- - - - -	SEE TM 743-200-1 (DUNNAGE LUMBER) AND VOLUNTARY PRODUCT STANDARD PS 20.
<u>NAILS</u>	- - - - -	ASTM F1667; COMMON STEEL NAIL NLCMS OR NLCMMS).
<u>PLYWOOD</u>	- - - - -	COMMERCIAL ITEM DESCRIPTION A-A-55057, INDUSTRIAL PLYWOOD, INTERIOR WITH EXTERIOR GLUE, GRADE C-D. IF SPECIFIED GRADE IS NOT AVAILABLE, A BETTER INTERIOR OR AN EXTERIOR GRADE MAY BE SUBSTITUTED.
<u>WIRE CARBON STEEL</u>	- - - - -	ASTM A853; ANNEALED AT FINISH, BLACK OXIDE FINISH, 0.0800" DIA, GRADE 1006 OR BETTER.
<u>STAPLE</u>	- - - - -	ASTM F1667; STFCs-189 OR STFCs-207, 15/16" OR 1" CROWN WIDTH X 3/4" LEG LENGTH FOR 3/4" STRAPPING, OR STFCs-224, 1-17/32" CROWN WIDTH X 3/4" LEG LENGTH FOR 1-1/4" STRAPPING.
<u>ANTI-CHAFING MATERIAL</u>	- - - - -	MIL-PRF-121 (OR EQUAL); NEUTRAL BARRIER MATERIAL.

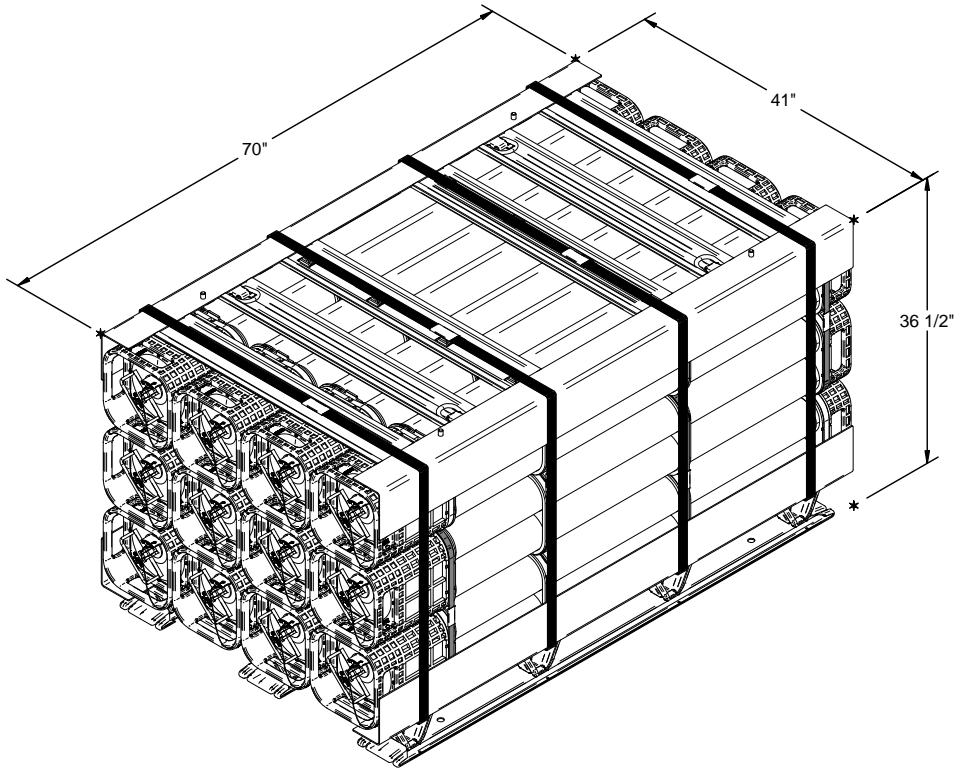

PALLET UNIT DATA

GROSS WEIGHT - - - - - 2,342 LBS
CUBE - - - - - 60.6 CU FT

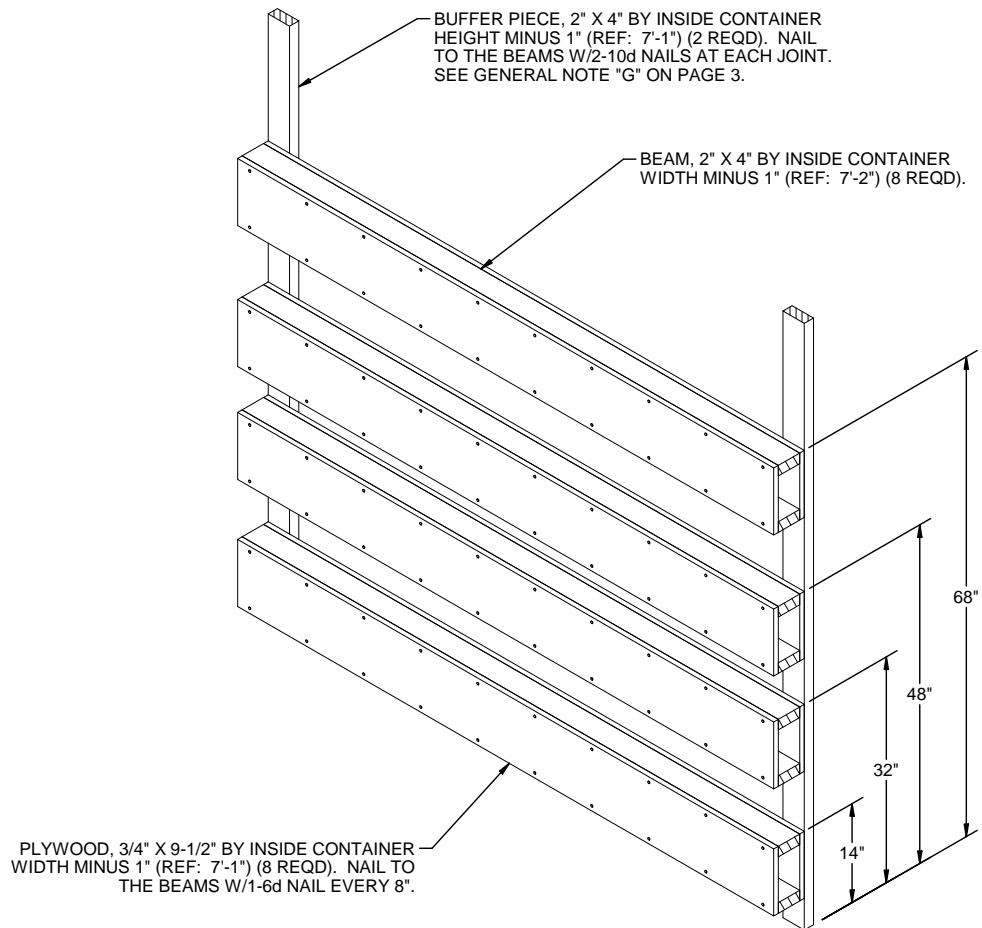

END BLOCKING ASSEMBLY

FOR A ONE-HIGH LOAD, ELIMINATE THE UPPER TWO BEAM ASSEMBLIES.

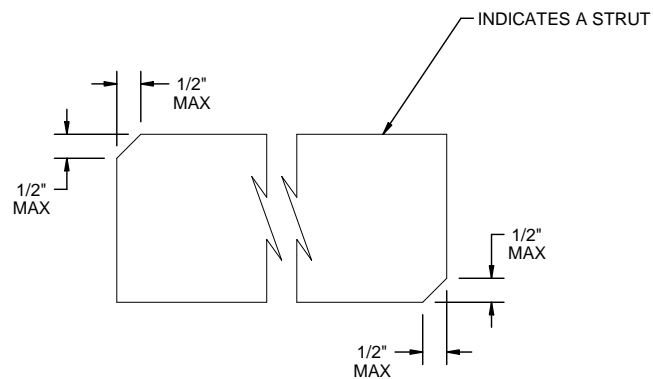

BEVEL CUT

IF DESIRED, EACH END OF A STRUT MAY BE BEVEL-CUT AS SHOWN ABOVE TO FACILITATE INSTALLING THE STRUTS WITH A "DRIVE" FIT.

VERTICAL PIECE, 2" X 4" BY INSIDE CONTAINER HEIGHT MINUS 1" (REF: 7'-4") (2 REQD).

VERTICAL PIECE, 2" X 4" X 70" (2 REQD).

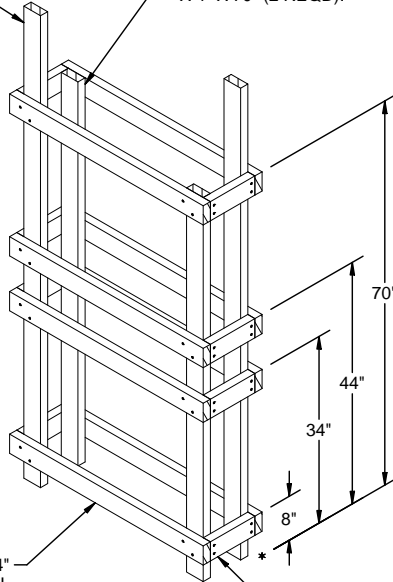

LONGITUDINAL PIECE, 2" X 4" X 40-3/4" (8 REQD). NAIL TO THE VERTICAL PIECES W/2-10d NAILS AT EACH JOINT.

LATERAL PIECE, 2" X 4" X 8" (8 REQD). NAIL TO THE VERTICAL PIECES W/2-10d NAILS AT EACH END.

CRIB FILL ASSEMBLY

THE DETAIL ABOVE IS FOR USE WITH A 2-PALLET HIGH LOAD. FOR A 1-HIGH LOAD, ELIMINATE THE FOUR UPPER LONGITUDINALS AND FOUR UPPER LATERAL PICES AND REDUCE THE SHORT VERTICAL PIECES TO 34".

HORIZONTAL PIECE, 2" X 4" X 9'-1" (4 REQD). NAIL TO THE VERTICAL PIECES W/2-10d NAILS AT EACH JOINT.

VERTICAL PIECE, 2" X 4" X 70" (4 REQD). LAMINATE TO THE FILL MATERIAL W/1-10d NAIL EVERY 10".

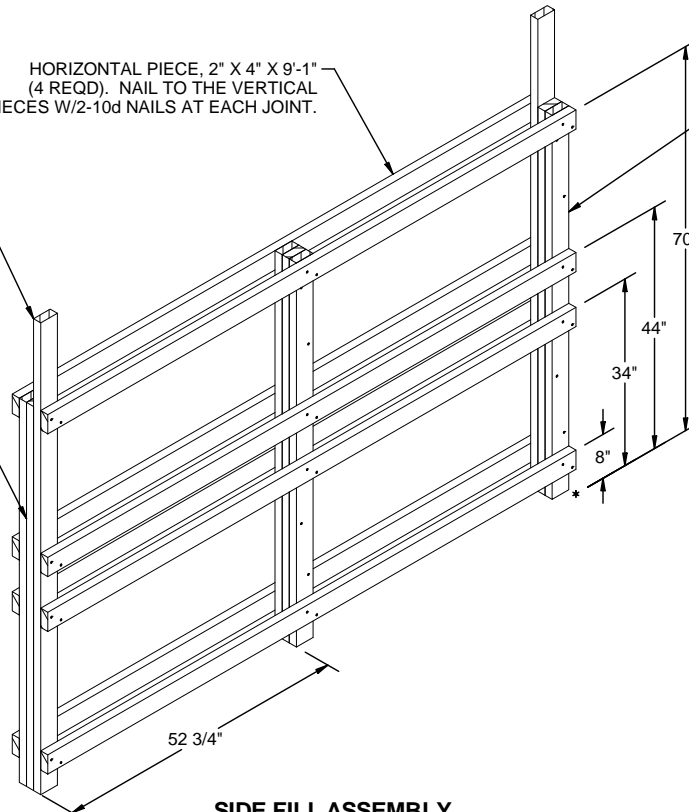

VERTICAL PIECE, 2" X 4" BY INSIDE CONTAINER HEIGHT MINUS 1" (REF: 6'-11") (2 REQD).

FILL MATERIAL, 1" OR 2" X 4" X 70" (AS REQD). LAMINATE TO THE LONG VERTICAL PIECES W/1-APPROPRIATE SIZED NAIL EVERY 10".

SIDE FILL ASSEMBLY

THE DETAIL ABOVE IS FOR USE WITH A 2-PALLET HIGH LOAD. FOR A 1-HIGH LOAD, ELIMINATE THE FOUR UPPER HORIZONTALS AND REDUCE THE HEIGHT OF THE SHORT VERTICAL PIECES AND FILL MATERIAL TO 34".

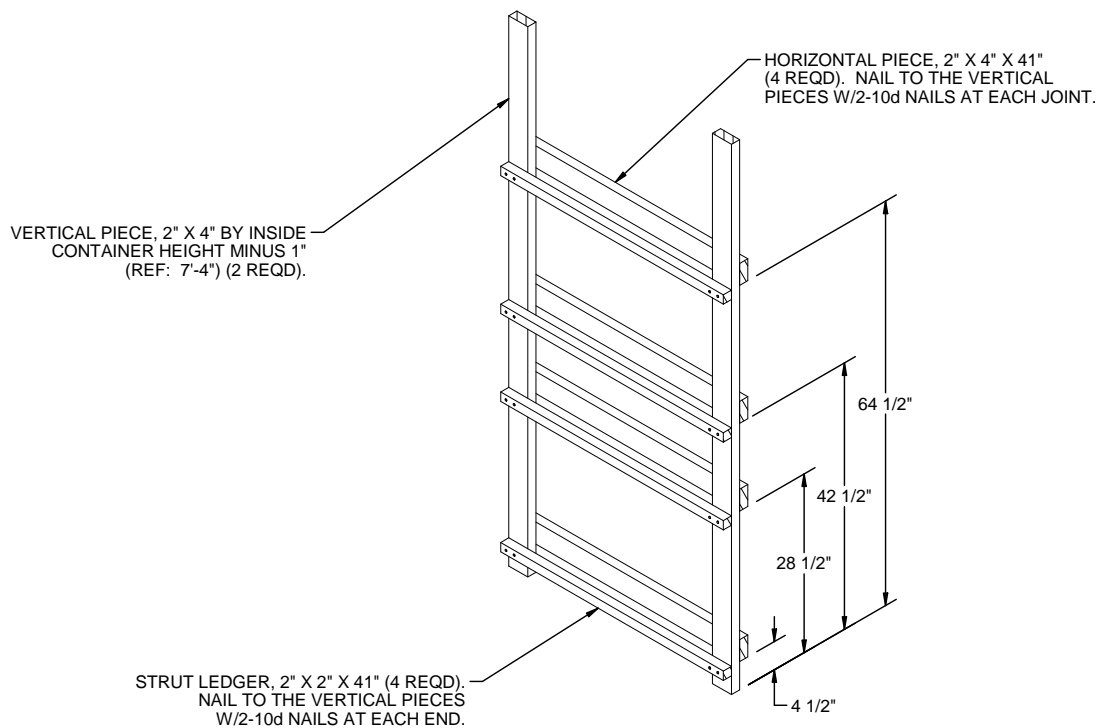

CENTER GATE

THE DETAIL ABOVE IS USED IN THE "LESS-THAN-FULL LOAD PROCEDURE" DEPICTED ON PAGE 8. THE DETAIL IS FOR USE WITH A 2-PALLET HIGH LOAD. FOR A 1-HIGH LOAD, ELIMINATE THE TWO UPPER HORIZONTALS AND TWO UPPER STRUT LEDGERS.

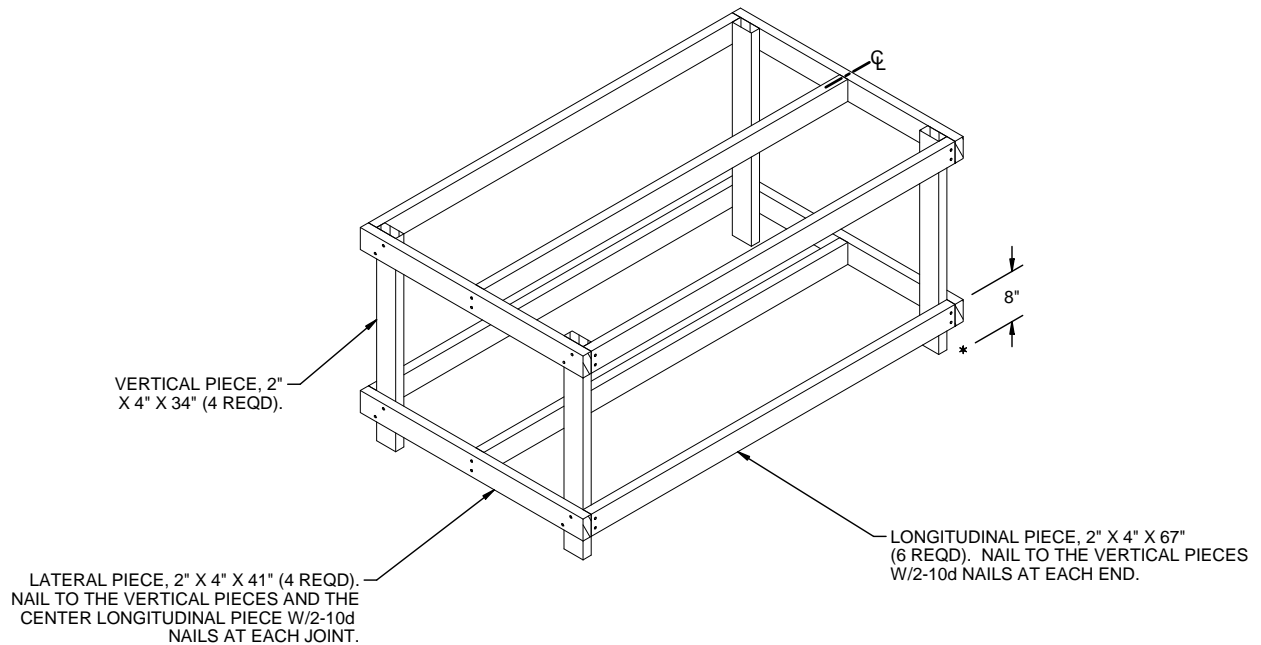

FILLER ASSEMBLY

FOR MINUS ONE PALLET UNIT. NO MORE THAN THREE FILLER ASSEMBLIES MAY BE USED FOR A 2-HIGH LOAD OR ONE FILLER ASSEMBLY MAY BE USED FOR A 1-HIGH LOAD.

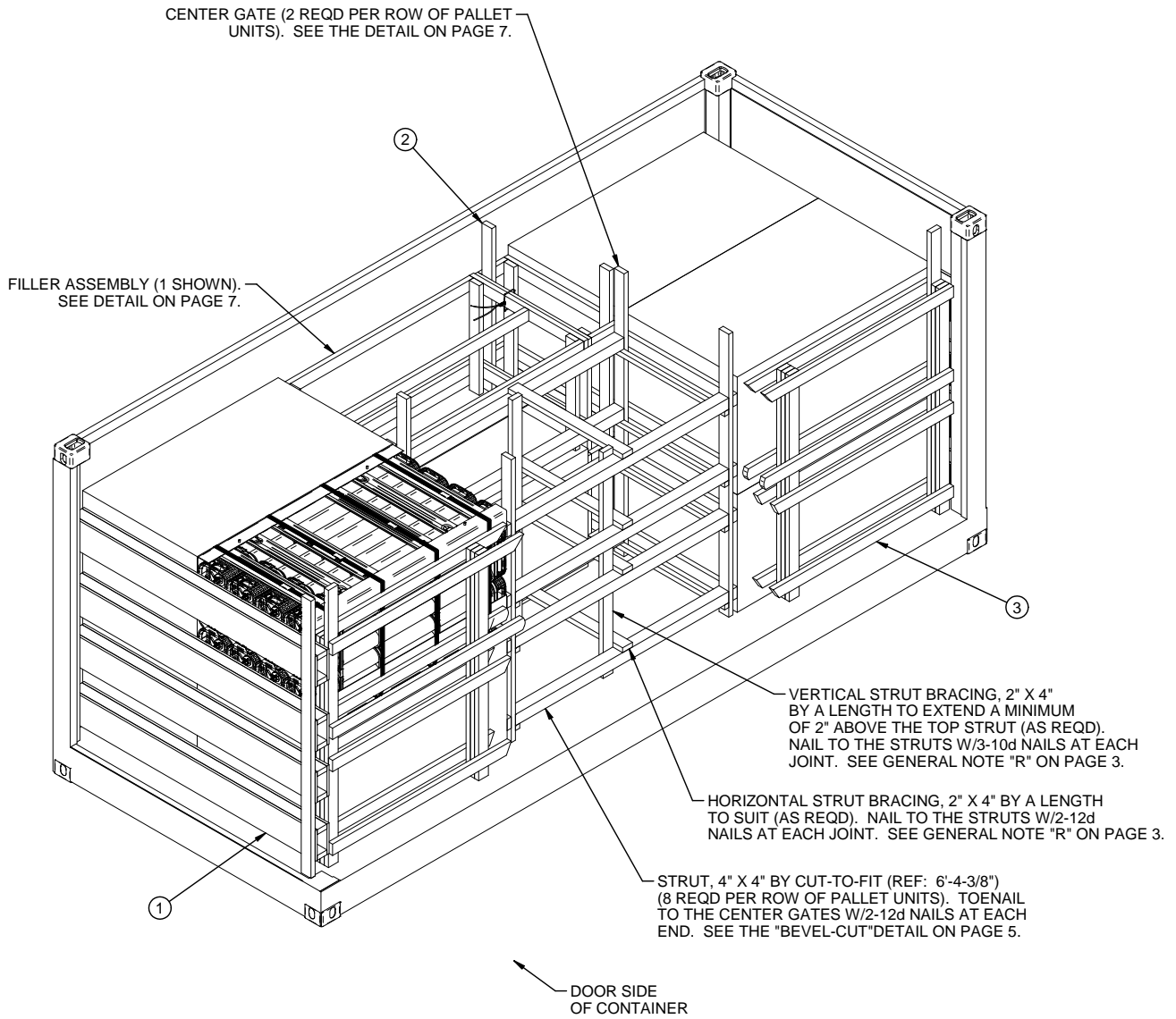

LESS-THAN-FULL-LOADPROCEDURE

THE DETAIL ABOVE DEPICTS A BLOCKING METHOD TO BE USED IN A LESS-THAN-FULL CONTAINER LOAD (LESS THAN 12 UNITS). KEY NUMBERS REFER TO KEY NUMBERS ON PAGE 2. SEE GENERAL NOTES "H", "O" AND "Q" ON PAGE 3.