

APPROVED BY
BUREAU OF EXPLOSIVES

J. H. Hershman
DATE 10/27/92

LOADING AND BRACING IN SIDE OPENING ISO CONTAINERS OF COMPLETE ROUNDS PACKED IN CYLINDRICAL METAL CONTAINERS

PA116 SERIES CONTAINERS

INDEX

<u>ITEM</u>	<u>PAGE(S)</u>
TYPICAL LOADING PROCEDURES - - - - -	2
GENERAL NOTES AND MATERIAL SPECIFICATIONS - - - - -	3
PALLET UNIT DETAIL - - - - -	4
DETAILS - - - - -	5-6

- LOADING AND BRACING SPECIFICATIONS SET FORTH WITHIN THIS DRAWING ARE APPLICABLE TO LOADS THAT ARE TO BE SHIPPED BY TRAILER/CONTAINER-ON-FLAT CAR (T/COFC) RAIL CARRIER SERVICE. THESE SPECIFICATIONS MAY ALSO BE USED FOR LOADS THAT ARE TO BE MOVED BY MOTOR OR WATER CARRIERS. SEE GENERAL NOTE "K" ON PAGE 3.

U.S. ARMY MATERIEL COMMAND DRAWING

APPROVED, U.S. ARMY ARMAMENT, MUNITIONS AND
CHEMICAL COMMAND

Timothy R. Fore

APPROVED BY ORDER OF COMMANDING GENERAL, U.S.
ARMY MATERIEL COMMAND

Allen L. Bryant

U.S. ARMY DEFENSE AMMUNITION CENTER AND SCHOOL

DRAFTSMAN

TECHNICIAN

ENGINEER

L. FIEFFER

VALIDATION
ENGINEERING
DIVISION

TRANSPORTATION
ENGINEERING
DIVISION

LOGISTICS
ENGINEERING
OFFICE

am JMK w. Jureich W.F. Ernst

JANUARY 1993

CLASS

DIVISION

DRAWING

FILE

19

48

4272/
48

15PM1016

DO NOT SCALE

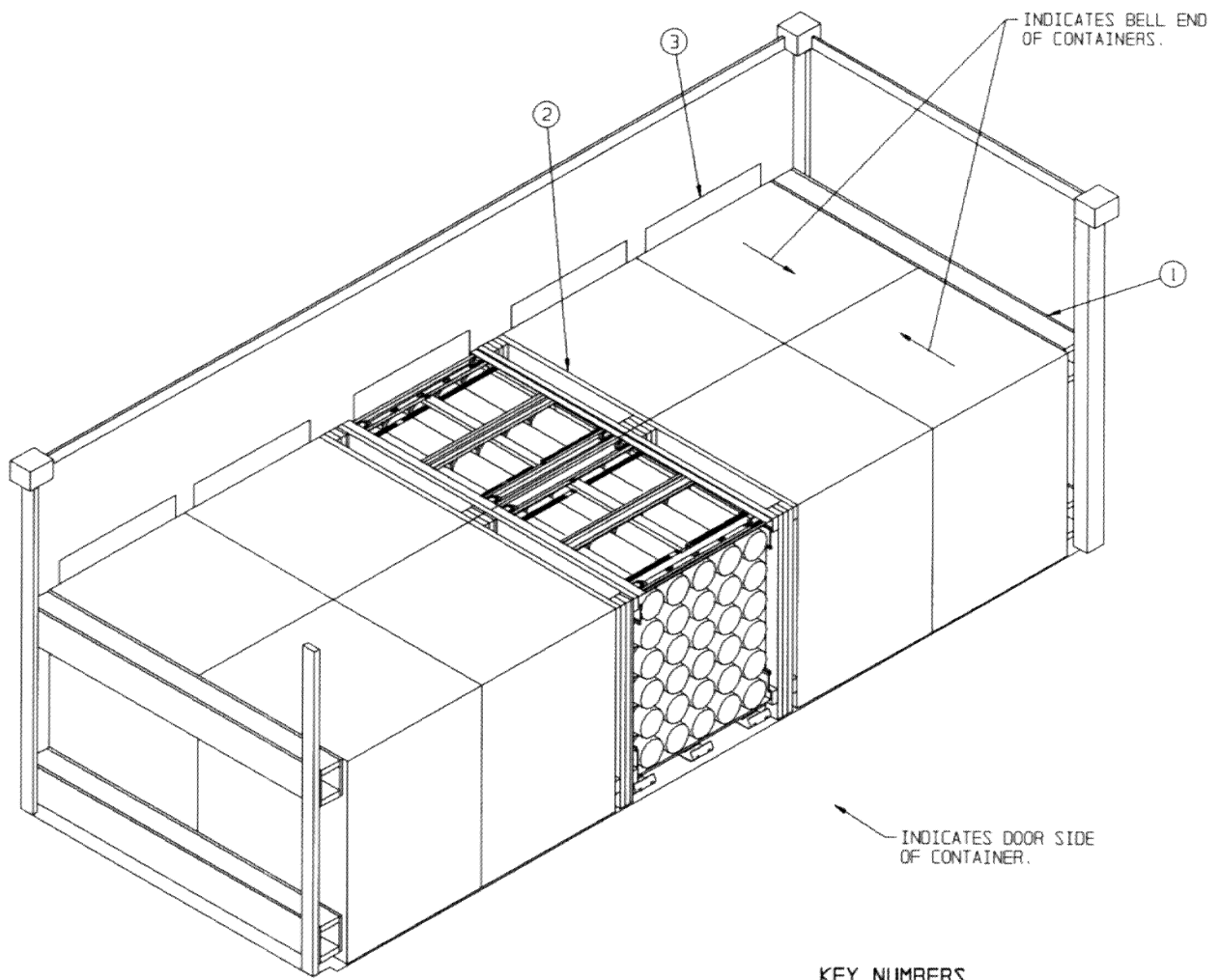

ISOMETRIC VIEW

KEY NUMBERS

- ① END BLOCKING ASSEMBLY (2 REOD). SEE THE DETAIL ON PAGE 5 AND THE "ALTERNATIVE END BLOCKING ASSEMBLY" ON PAGE 6.
- ② SEPARATOR ASSEMBLY (4 REOD). SEE THE DETAIL ON PAGE 5.
- ③ ANTI-CHAFING, FIBERBOARD (AS REOD). AFFIX (STRAP TAPE, ETC.) TO THE SIDEWALL OF THE PALLET UNIT TO ELIMINATE METAL-TO-METAL CONTACT. ANTI-CHAFING IS NOT REQUIRED BETWEEN PALLET UNITS IN EITHER THE LATERAL OR LONGITUDINAL DIRECTIONS. NOTE: PLYWOOD OR HARDBOARD MAY BE USED IN PLACE OF THE FIBERBOARD, IF DESIRED AND IF SPACE PERMITS, AS LONG AS THE PLYWOOD OR HARDBOARD IS SECURED TO PREVENT UNDUE MOVEMENT.

<u>BILL OF MATERIAL</u>		
LUMBER	LINEAR FEET	BOARD FEET
1" X 4"	18	6
2" X 2"	6	2
2" X 4"	117	78
2" X 6"	87	87
NAILS	NO. REOD	POUNDS
6d (2")	196	1-1/4
10d (3")	196	3-1/4
PLYWOOD, 3/4"	45.39 SQ FT REOD	93.62 LBS
ANTI-CHAFING MATERIAL	AS REOD	NIL

LOAD AS SHOWN

ITEM	QUANTITY	WEIGHT (APPROX)
PALLET UNIT	10	24,440 LBS
DUNNAGE		445 LBS
CONTAINER		6,050 LBS
TOTAL WEIGHT		30,935 LBS (APPROX)

(GENERAL NOTES CONTINUED)

- N. THE QUANTITY OF PALLET UNITS SHOWN IN THE LOAD ON PAGE 2 MAY BE REDUCED FOR SHIPMENT, IF DESIRED. SEE THE FILLER ASSEMBLY ON PAGE 4. WHEN A CONTAINER IS TO BE LOADED WITH A REDUCED QUANTITY OF LADING UNITS, THE LENGTHWISE CENTER OF GRAVITY OF THE LOAD MUST BE WITHIN 12", IN EITHER DIRECTION, OF THE MID-POINT OF THE CONTAINER.
 - 1. IF A LOAD IS REDUCED BY ONLY A SMALL AMOUNT (ONE OR TWO LADING UNITS), LADING UNITS NORMALLY MAY BE ELIMINATED FROM THE CENTER OF THE LOAD.
 - 2. IF A LOAD IS REDUCED BY A LARGE AMOUNT (MORE THAN TWO LADING UNITS), LADING UNITS SHOULD BE ELIMINATED AS REQUIRED AND THE TOTAL LOAD SHIFTED FORE OR AFT, AS NECESSARY, TO ACHIEVE A SYMMETRICAL WEIGHT DISTRIBUTION. THE DEPICTED PROCEDURES WILL BE FOLLOWED AS CLOSELY AS POSSIBLE, MAKING ONLY THOSE ADJUSTMENTS TO THE DUNNAGE WHICH ARE REQUIRED TO ACCOMMODATE THE NUMBER OF UNITS TO BE SHIPPED.
- O. RECOMMENDED SEQUENTIAL LOADING PROCEDURES:
 - 1. PREFABRICATE TWO END BLOCKING ASSEMBLIES AND FOUR SEPARATOR ASSEMBLIES.
 - 2. INSTALL ONE END BLOCKING ASSEMBLY.
 - 3. INSTALL ANTI-CHAFING FIBERBOARD MATERIAL, LOAD TWO PALLET UNITS AND INSTALL ONE SEPARATOR ASSEMBLY.
 - 4. REPEAT STEP 2.
 - 5. REPEAT STEP 3.
 - 6. LOAD CENTER PALLET UNIT.
 - 7. REPEAT STEP 3.
 - 8. REPEAT STEP 5.
 - 9. REPEAT STEP 6.
 - 10. INSTALL REMAINING ANTI-CHAFING MATERIAL BETWEEN THE PALLET UNITS AND THE CONTAINER DOORS.

MATERIAL SPECIFICATIONS

- LUMBER - - - - - : SEE TM 743 200 1 (DUNNAGE LUMBER) AND FED SPEC MM-L-751.
- NAILS - - - - - : FED SPEC FF-N-105; COMMON.
- PLYWOOD - - - - - : COMMERCIAL ITEM DESCRIPTION A-A-55057, TYPE A, CONSTRUCTION AND INDUSTRIAL PLYWOOD, INTERIOR WITH EXTERIOR GLUE, GRADE C-D. IF SPECIFIED GRADE IS NOT AVAILABLE, A BETTER INTERIOR OR AN EXTERIOR GRADE MAY BE SUBSTITUTED.
- ANTI-CHAFING MATERIAL - - - - - : MIL-B-121 (OR EQUAL); NEUTRAL BARRIER MATERIAL.

GENERAL NOTES

- A. THIS DOCUMENT HAS BEEN PREPARED AND ISSUED IN ACCORDANCE WITH AR 740-1 AND AUGMENTS TM 743-200-1 (CHAPTER 5).
- B. THE SPECIFIED OUTLOADING PROCEDURES ARE APPLICABLE TO LOADS OF COMPLETE ROUNDS PACKED IN PA116 SERIES METAL CONTAINERS. SUBSEQUENT REFERENCE TO PALLET UNIT HEREIN MEANS THE PALLET UNIT WITH AMMUNITION ITEMS. SEE PAGE 4 AND AMC DRAWING 19-48-4231/48-20PM1006 FOR DETAILS OF THE PALLET UNIT. CAUTION: REGARDLESS OF THE QUANTITY OF CONTAINERS TO BE SHIPPED, THE "MAXIMUM GROSS WEIGHT" OF THE SIDE OPENING ISO CONTAINER MUST NOT BE EXCEEDED.
- C. THE LOAD AS SHOWN IS BASED ON A 6,050 POUND 20' LONG BY 8' WIDE BY 8'-6" HIGH SIDE OPENING ISO CONTAINER WITH INSIDE DIMENSIONS OF 19'-4" LONG BY 89" WIDE BY 88" HIGH. THE LOAD IS DESIGNED FOR TRAILER/CONTAINER-ON-FLATCAR (T/COFC) SHIPMENT, HOWEVER, THE LOAD AS DESIGNED CAN ALSO BE MOVED BY OTHER SURFACE MODES OF TRANSPORT. NOTICE: OTHER CONTAINERS OF THE SAME DESIGN CONFIGURATION CAN BE USED.
- D. WHEN LOADING PALLET UNITS, THEY ARE TO BE POSITIONED SO AS TO ACHIEVE A TIGHT LOAD (TIGHT AGAINST THE DUNNAGE ASSEMBLIES). ALTHOUGH A TOTAL OF 1-1/2" OF UNBLOCKED SPACE ACROSS THE WIDTH OF A LOAD BAY IS PERMITTED, LATERAL VOIDS WITHIN THE LOAD ARE TO BE HELD TO A MINIMUM. EXCESSIVE SLACK CAN BE ELIMINATED FROM A LOAD BY LAMINATING ADDITIONAL PIECES OF APPROPRIATE THICKNESS TO THE VERTICAL PIECES ON THE SEPARATOR ASSEMBLIES. NAIL EACH ADDITIONAL PIECE W/1 APPROPRIATELY SIZED NAIL EVERY 12". ADDITIONALLY, THE THICKNESS AND/OR QUANTITY OF THE VERTICAL PIECES IN THE SEPARATOR ASSEMBLIES MAY BE ADJUSTED AS REQUIRED TO FACILITATE VARIANCE IN THE PALLET UNIT SIZE.
- E. DUNNAGE LUMBER SPECIFIED IS OF NOMINAL SIZE. FOR EXAMPLE, 1" X 4" MATERIAL IS ACTUALLY 3/4" THICK BY 3-1/2" WIDE AND 2" X 6" MATERIAL IS ACTUALLY 1-1/2" BY 5-1/2" WIDE.
- F. A STAGGERED NAILING PATTERN WILL BE USED WHENEVER POSSIBLE WHEN NAILS ARE DRIVEN INTO JOINTS OF DUNNAGE ASSEMBLIES OR WHEN LAMINATING DUNNAGE. ADDITIONALLY, THE NAILING PATTERN FOR AN UPPER PIECE OF LAMINATED DUNNAGE WILL BE ADJUSTED AS REQUIRED SO THAT A NAIL FOR THAT PIECE WILL NOT BE DRIVEN THROUGH ONTO OR RIGHT BESIDE A NAIL IN A LOWER PIECE.
- G. IN SOME CONTAINERS, SUCH AS SOME ALL STEEL CONTAINERS, THERE IS A SLOT AT THE CORNERS OF THE ENDWALLS. A PIECE OF DUNNAGE MATERIAL MUST BE LAMINATED TO THE BUFFER PIECES OF THE END BLOCKING ASSEMBLIES TO PROVIDE A FLAT SURFACE FOR THE 2" X 4" BUFFER PIECES. A PIECE OF 2" X 4", 2" X 3", OR A SPECIAL WIDTH PIECE CUT-TO-FIT CAN BE USED. THIS FILL PIECE WILL BE NAILED WITH ONE APPROPRIATELY SIZED NAIL EVERY 12". THIS PIECE IS NOT REQUIRED WHEN THE ENDWALL OF THE CONTAINER IS SMOOTH AND FLAT.
- H. CAUTION: DO NOT NAIL DUNNAGE MATERIAL TO THE CONTAINER WALLS OR FLOOR. ALL NAILING WILL BE WITHIN THE DUNNAGE.
- J. PORTIONS OF THE CONTAINER DEPICTED WITHIN THIS DRAWING, SUCH AS THE SIDE DOORS, HAVE NOT BEEN SHOWN IN THE LOAD VIEWS FOR CLARITY PURPOSES.
- K. REQUIREMENTS CITED WITHIN THE BUREAU OF EXPLOSIVES PAMPHLET 6C APPLY WHEN THE SHIPMENT MOVES BY TRAILER/CONTAINER-ON-FLATCAR (T/COFC). SPECIAL T/COFC NOTES FOLLOW:
 - 1. A LOADED CONTAINER MUST BE ON A CHASSIS EQUIPPED WITH TWO BOGIE ASSEMBLIES WHEN BEING MOVED IN TOFC SERVICE.
 - 2. THE LOAD LIMIT OF A T/COFC RAILCAR MUST NOT BE EXCEEDED, NOR WILL A CAR BE LOADED SO THAT THE TRUCK UNDER ONE END OF THE CAR CARRIES MORE THAN ONE-HALF OF THE LOAD LIMIT FOR THAT CAR.
- L. DURING INTRASTATE AND/OR INTERSTATE MOVES BY MOTOR CARRIER, A PROPER CHASSIS OR MODIFIED FLATBED TRAILER MUST BE USED TO PRECLUDE VIOLATION OF ONE OR MORE "WEIGHT LAWS" APPLICABLE TO THE STATE OR STATES INVOLVED.
- M. CONVERSION TO METRIC EQUIVALENTS: DIMENSIONS WITHIN THIS DOCUMENT ARE EXPRESSED IN INCHES AND WEIGHTS ARE EXPRESSED IN POUNDS. WHEN NECESSARY, THE METRIC EQUIVALENTS MAY BE COMPUTED ON THE BASIS OF ONE INCH EQUALS 25.4MM AND ONE POUND EQUALS 0.454 KG.

(CONTINUED AT LEFT)

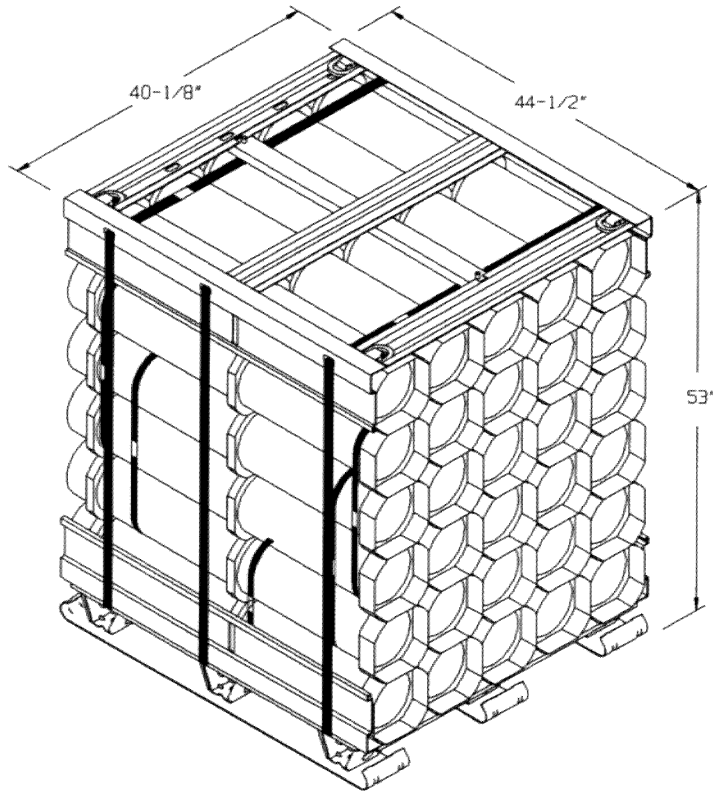

PALLET UNIT

UNIT WEIGHT ----- 2,444 LBS (APPROX)
 CUBE ----- 54.8 CU FT (APPROX)

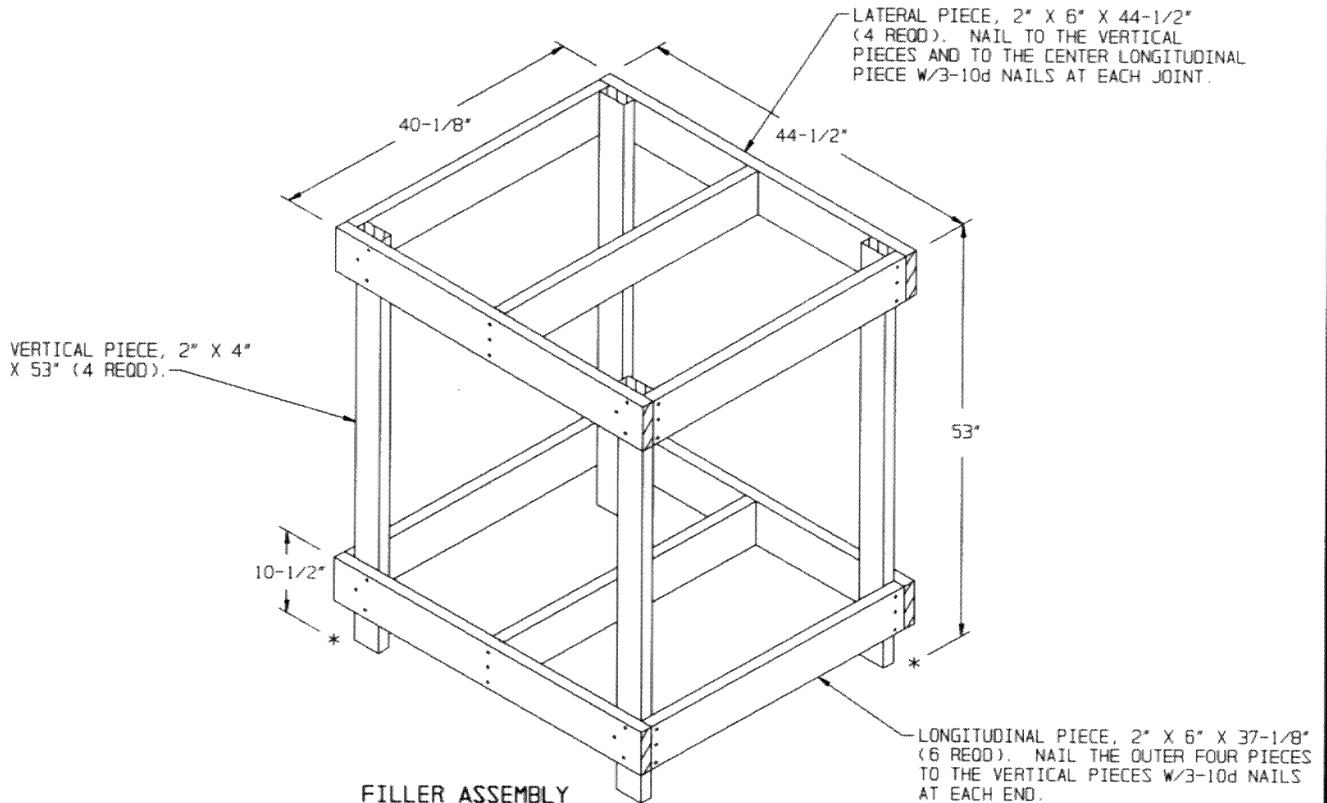

FILLER ASSEMBLY

THE ASSEMBLY DEPICTED ABOVE IS FOR USE IN PLACE OF AN OMITTED PALLET UNIT.
 FILLER ASSEMBLIES MUST BE WIRE TIED TO ADJACENT PALLET UNITS TO PREVENT
 UNQUE MOVEMENT. NO MORE THAN FIVE FILLER ASSEMBLIES MAY BE USED PER LOAD.
 DO NOT INSTALL A FILLER ASSEMBLY IMMEDIATELY ADJACENT TO ANOTHER FILLER ASSEMBLY.

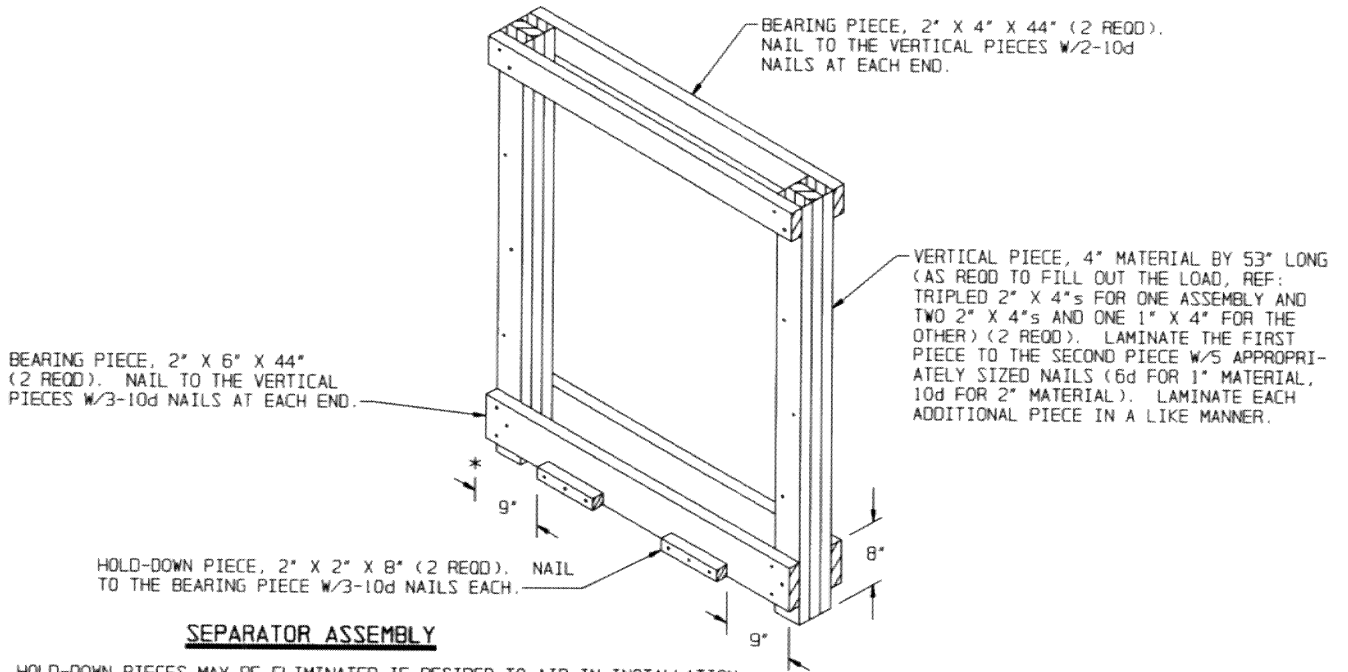
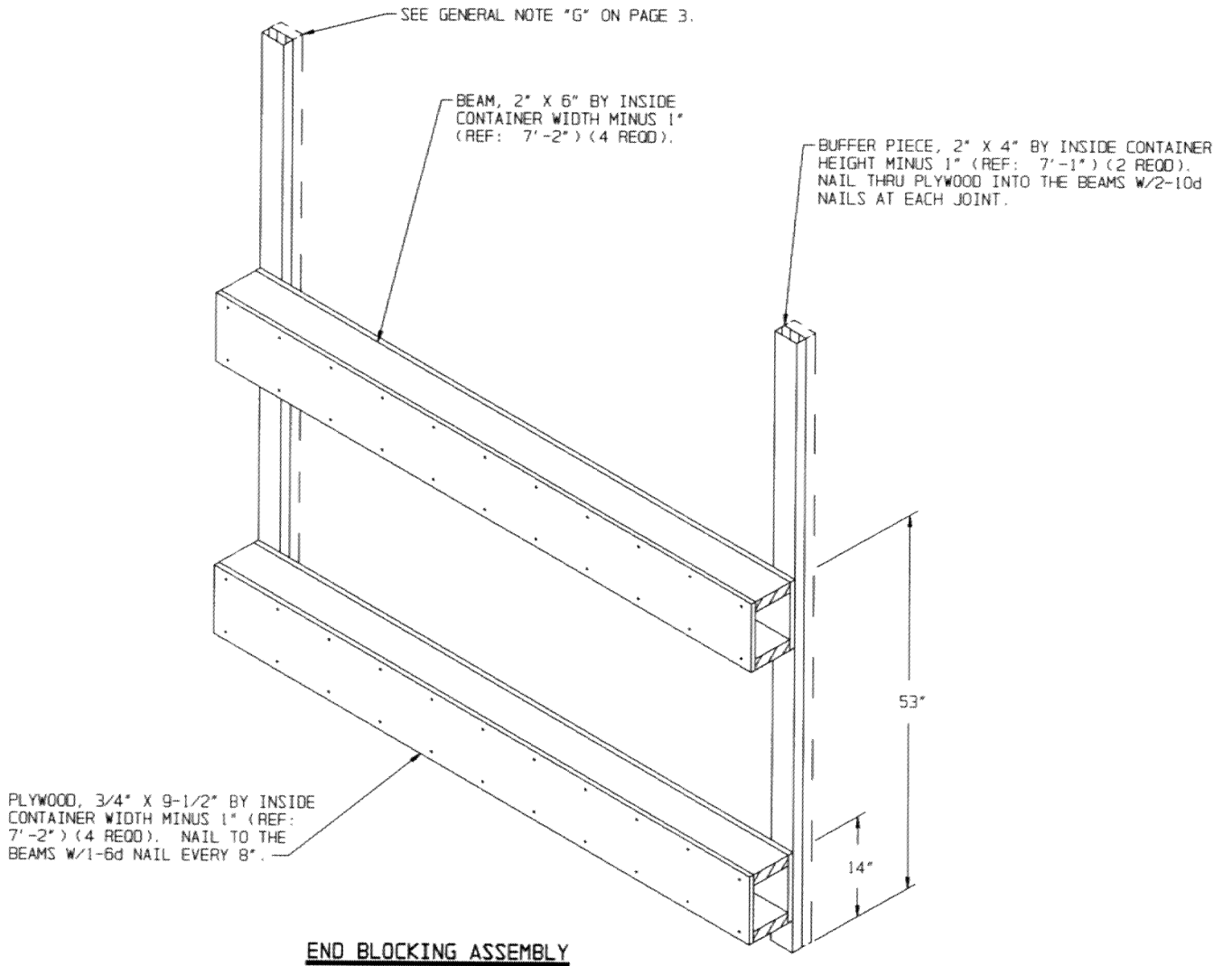

NOTE: HOLD-DOWN PIECES MAY BE ELIMINATED IF DESIRED TO AID IN INSTALLATION. IF HOLD-DOWN PIECES ARE ELIMINATED, HOWEVER, THE SEPARATOR ASSEMBLIES MUST BE WIRE TIED TO THE PALLET UNITS TO PREVENT MOVEMENT.

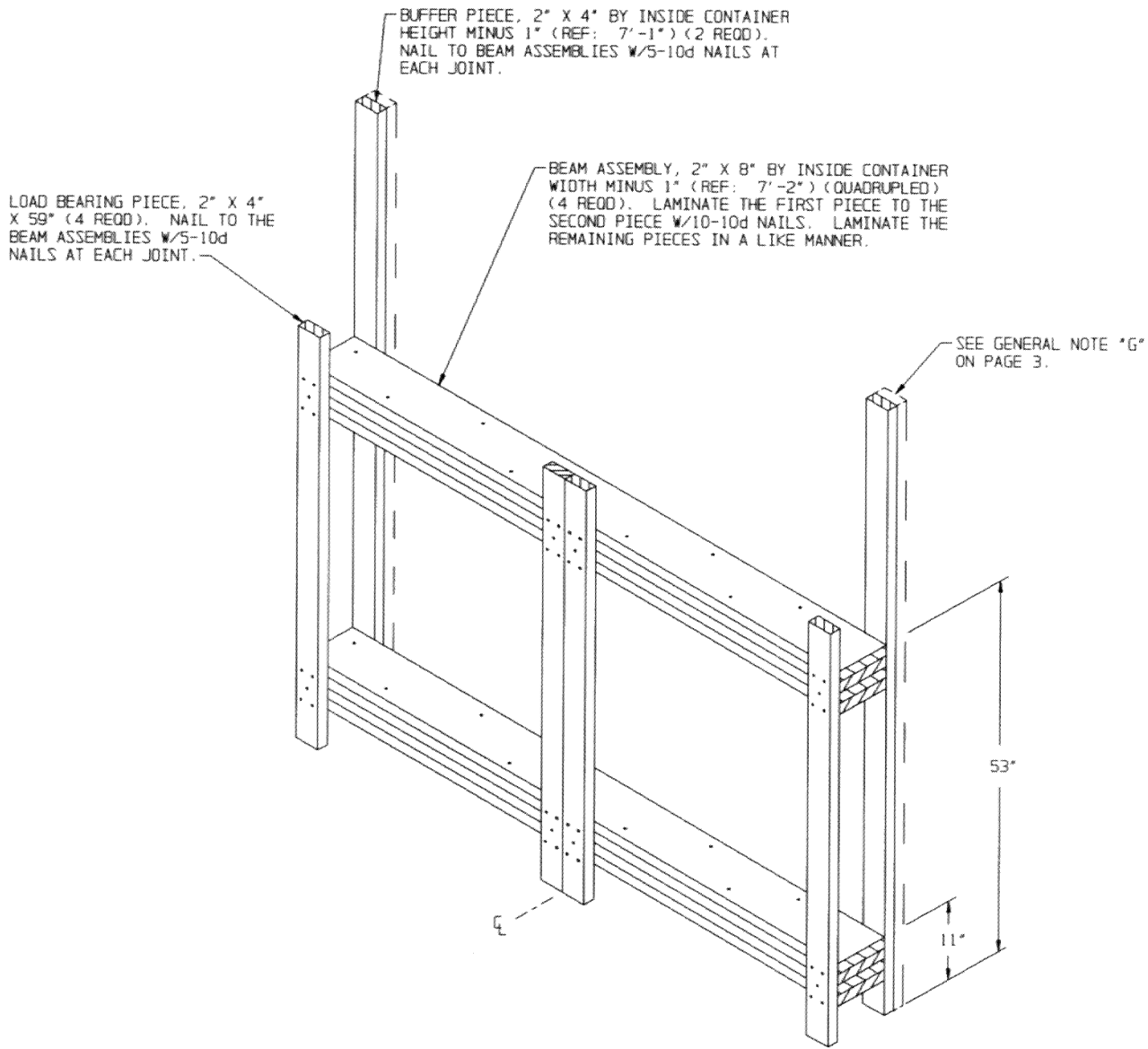

ALTERNATIVE END BLOCKING ASSEMBLY

NOTE: THIS END BLOCKING ASSEMBLY MAY BE USED IN PLACE OF THE END BLOCKING ASSEMBLY DEPICTED ON PAGE 5, IF DESIRED. NOTE THAT THE SEPARATOR ASSEMBLIES WILL HAVE TO BE MODIFIED TO COMPLETELY FILL OUT THE VOID WITHIN THE LOAD.