

*[Signature]*

DATE 11/10/04

# LOADING AND BRACING IN SIDE OPENING ISO CONTAINERS OF PROPELLING CHARGES PACKED IN CYLINDRICAL METAL CONTAINERS

---

## M13 SERIES CONTAINER

INDEX

<u>ITEM</u>	<u>PAGE(S)</u>
GENERAL NOTES AND MATERIAL SPECIFICATIONS - - - - -	2
PALLET UNIT DETAILS - - - - -	3
6-UNIT LOAD (FLAT DUNNAGE - BASIC HEIGHT) - - - - -	4-5
12-UNIT LOAD (FLAT DUNNAGE - DECREASED HEIGHT) - - - - -	6-7
6-UNIT LOAD (ROUTED DUNNAGE - BASIC HEIGHT) - - - - -	8-9
12-UNIT LOAD (ROUTED DUNNAGE - DECREASED HEIGHT) - - - - -	10-11
DETAILS - - - - -	12-15

- LOADING AND BRACING SPECIFICATIONS SET FORTH WITHIN THIS DRAWING ARE APPLICABLE TO LOADS THAT ARE TO BE SHIPPED BY TRAILER/CONTAINER-ON-FLATCAR (T/COFC) RAIL CARRIER SERVICE. THESE SPECIFICATIONS MAY ALSO BE USED FOR LOADS THAT ARE TO BE MOVED BY MOTOR OR WATER CARRIERS.

### U.S. ARMY MATERIEL COMMAND DRAWING

APPROVED, U.S. ARMY JOINT MUNITIONS COMMAND  <i>[Signature]</i>	<b>CAUTION: VERIFY PRIOR TO USE AT WWW.DAC.ARMY.MIL THAT THIS IS THE MOST CURRENT VERSION OF THIS DOCUMENT. THIS IS PAGE 1 OF 16.</b>				
	DO NOT SCALE		MAY 2004		
APPROVED BY ORDER OF COMMANDING GENERAL, U.S. ARMY MATERIEL COMMAND  <i>[Signature]</i>  U.S. ARMY DEFENSE AMMUNITION CENTER	ENGINEER OR TECHNICIAN	BASIC REV.	RICHARD GARSIDE		
	TRANSPORTATION ENGINEERING DIVISION	<i>[Signature]</i>			
	VALIDATION ENGINEERING DIVISION	TESTED	CLASS	DIVISION	DRAWING
ENGINEERING DIRECTORATE		19	48	4264/ 2	FILE  15PM1003

**GENERAL NOTES**

- A. THIS DOCUMENT HAS BEEN PREPARED AND ISSUED IN ACCORDANCE WITH AR 740-1 AND AUGMENTS TM 743-200-1 (CHAPTER 5).
- B. THE OUTLOADING PROCEDURES SPECIFIED IN THIS DRAWING ARE APPLICABLE FOR THE M13 SERIES PROPELLING CHARGE CONTAINER ASSEMBLED ON THE 40" X 48" 4-WAY ENTRY PALLET. SEE PAGE 3 FOR DETAILS OF THE PALLET UNITS. SEE U. S. ARMY MATERIEL COMMAND DRAWING 19-48-4042A/2-20PM1001 FOR UNITIZATION PROCEDURES FOR THE M13 SERIES CONTAINERS. CAUTION: REGARDLESS OF THE QUANTITY OF UNITS TO BE SHIPPED, THE "MAXIMUM GROSS WEIGHT" OF THE SIDE OPENING ISO CONTAINER MUST NOT BE EXCEEDED.
- C. THE LOADS AS SHOWN ARE BASED ON 6,050 POUND 20' LONG BY 8' WIDE BY 8'-6" HIGH SIDE OPENING ISO CONTAINER WITH INSIDE DIMENSIONS OF 19'-4" LONG BY 89" WIDE BY 88" HIGH AND A MAXIMUM GROSS WEIGHT OF 52,910 POUNDS. THE LOAD IS DESIGNED FOR TRAILER/CONTAINER-ON-FLATCAR (T/COFC) SHIPMENT, HOWEVER, THE LOAD AS DESIGNED CAN ALSO BE MOVED BY MOTOR OR WATER CARRIERS. NOTICE: OTHER CONTAINERS OF THE SAME DESIGN CONFIGURATION CAN ALSO BE USED.
- D. WHEN LOADING THE UNITS, THEY ARE TO BE POSITIONED SO AS TO ACHIEVE A TIGHT LOAD (TIGHT AGAINST THE DUNNAGE ASSEMBLIES). THE UNBLOCKED SPACE ACROSS THE WIDTH OF A LOAD BAY IS NOT TO EXCEED 1-1/2". EXCESSIVE SLACK CAN BE ELIMINATED FROM A LOAD BY ADDING ADDITIONAL HORIZONTAL PIECES TO THE CRIB FILL ASSEMBLIES.
- E. DUNNAGE LUMBER SPECIFIED IS OF NOMINAL SIZE, FOR EXAMPLE, 1" X 6" MATERIAL IS ACTUALLY 3/4" THICK BY 5-1/2" WIDE AND 2" X 4" MATERIAL IS ACTUALLY 1-1/2" THICK BY 5-1/2" WIDE.
- F. A STAGGERED NAILING PATTERN WILL BE USED WHENEVER POSSIBLE WHEN NAILS ARE DRIVEN INTO JOINTS OF DUNNAGE ASSEMBLIES OR WHEN LAMINATING DUNNAGE. ADDITIONALLY, THE NAILING PATTERN FOR AN UPPER PIECE OF LAMINATED DUNNAGE WILL BE ADJUSTED AS REQUIRED SO THAT A NAIL FOR THAT PIECE WILL NOT BE DRIVEN THROUGH, ONTO, OR RIGHT BESIDE A NAIL IN A LOWER PIECE.
- G. IN SOME CONTAINERS THERE IS A SLOT AT THE CORNERS OF THE ENDWALLS. PIECES OF DUNNAGE MATERIAL MUST BE LAMINATED TO THE BUFFER PIECES ON THE END BLOCKING ASSEMBLIES TO PROVIDE A FLAT SURFACE FOR THE BUFFER PIECES. A PIECE OF 2" X 4", 2" X 3" OR A SPECIAL WIDTH PIECE CUT-TO-FIT CAN BE USED. THIS FILL PIECE WILL BE NAILED WITH ONE APPROPRIATELY SIZED NAIL EVERY 12". NOTE THAT SOME CONTAINERS ARE EQUIPPED WITH "TIE-BARS" IN THE CORNER SLOT, WHICH PRECLUDE THE USE OF A FULL HEIGHT FILL PIECE. WHEN "TIE-BARS" ARE PRESENT, THE FILL PIECE MUST BE INSTALLED IN SEGMENTS DESIGNED TO FIT BETWEEN THE "TIE-BARS" VERTICALLY. THE FILL PIECE(S) IS NOT REQUIRED WHEN THE CORNER PORTIONS OF THE CONTAINER ENDWALLS ARE SMOOTH AND FLAT. DO NOT ALLOW ANY DUNNAGE ASSEMBLY TO CONTACT THE CONTAINER ENDWALLS, ONLY THE CORNER POSTS OF THE CONTAINER SHOULD BE USED FOR LONGITUDINAL BLOCKING.
- H. CAUTION: DO NOT NAIL DUNNAGE MATERIAL TO THE CONTAINER WALLS OR FLOOR. ALL NAILING WILL BE WITHIN THE DUNNAGE. PORTIONS OF THE CONTAINER DEPICTED WITHIN THIS DRAWING, SUCH AS THE SIDE DOORS, HAVE NOT BEEN SHOWN IN THE LOAD VIEW FOR CLARITY PURPOSES.
- J. CONVERSION TO METRIC EQUIVALENTS: DIMENSIONS WITHIN THIS DOCUMENT ARE EXPRESSED IN INCHES, AND WEIGHTS ARE EXPRESSED IN POUNDS. WHEN NECESSARY, THE METRIC EQUIVALENTS MAY BE COMPUTED ON THE BASIS OF ONE INCH EQUALS 25.4MM AND ONE POUND EQUALS 0.454 KG.

(CONTINUED AT RIGHT)

**(GENERAL NOTES CONTINUED)**

- K. MAXIMUM LOAD WEIGHT CRITERIA:  
THE MAXIMUM LOAD WEIGHTS ARE CONTROLLED BY EQUIPMENT CAPACITY FACTORS. ALTHOUGH THE HEAVIEST MAXIMUM LOADS ARE DELINEATED IN THE LOAD VIEWS, PROVISIONS ARE INCLUDED WITHIN THIS DRAWING SO THAT THE BASIC LOADS CAN BE ADJUSTED TO SATISFY A LESSER QUANTITY OF LADING UNITS. DEPENDING ON TRANSPORTATION ROUTING, IT MAY BE NECESSARY TO REDUCE THE LOAD WEIGHT TO SATISFY "WEIGHT LAWS" OF CERTAIN STATES. ALSO, IT MAY BE NECESSARY TO REDUCE THE LOAD WEIGHT TO SATISFY OTHER WEIGHT RESTRICTIONS IMPOSED ON THE INTERMODAL CONTAINER SYSTEM.
- L. REQUIREMENTS CITED WITHIN THE ASSOCIATION OF AMERICAN RAILROADS (AAR) INTERMODAL LOADING GUIDE APPLY WHEN THE SHIPMENT MOVES BY TRAILER/CONTAINER-ON-FLATCAR (T/COFC). SPECIAL T/COFC NOTES FOLLOW:
  - A. A LOADED CONTAINER MUST BE ON A CHASSIS EQUIPPED WITH TWO BOGIE ASSEMBLIES WHEN BEING MOVED IN TOFC SERVICE.
  - B. THE LOAD LIMIT OF A T/COFC RAILCAR MUST NOT BE EXCEEDED, NOR WILL A CAR BE LOADED SO THAT THE TRUCK UNDER ONE END OF THE CAR CARRIES MORE THAN ONE-HALF OF THE LOAD LIMIT FOR THAT CAR.
- M. DURING INTRASTATE AND/OR INTERSTATE MOVES BY MOTOR CARRIER, A PROPER CHASSIS OR MODIFIED FLATBED TRAILER MUST BE USED TO PRECLUDE VIOLATION OF ONE OR MORE "WEIGHT LAWS" APPLICABLE TO THE STATE OR STATES INVOLVED.
- N. WHETHER A CONTAINER IS FULL OR IS LOADED WITH A REDUCED QUANTITY OF LADING UNITS, THE LENGTHWISE CENTER OF GRAVITY OF THE LOAD MUST BE WITHIN 12", IN EITHER DIRECTION, OF THE MID-POINT OF THE CONTAINER.
- O. THE QUANTITY OF PALLET UNITS SHOWN IN THE LOAD ON PAGES 4, 6, 8 AND 10 MAY BE REDUCED FOR SHIPMENT, IF DESIRED. SEE THE OMITTED UNIT ASSEMBLY ON PAGE 14.

**MATERIAL SPECIFICATIONS**

- LUMBER - - - - - : SEE TM 743-200-1 (DUNNAGE LUMBER) AND VOLUNTARY PRODUCT STANDARD PS 20.
- NAILS - - - - - : ASTM F1667; COMMON STEEL NAIL (NLCMS OR NLCMMS).
- PLYWOOD - - - - - : COMMERCIAL ITEM DESCRIPTION A-A-55057, INDUSTRIAL PLYWOOD, INTERIOR WITH EXTERIOR GLUE, GRADE C-D. IF SPECIFIED GRADE IS NOT AVAILABLE, A BETTER INTERIOR OR AN EXTERIOR GRADE MAY BE SUBSTITUTED.

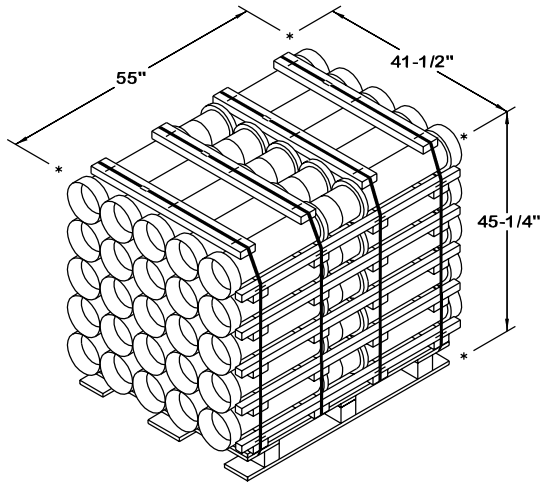

**FLAT DUNNAGE METHOD (BASIC HEIGHT)**

CONTAINER - - - - - 50 EACH @ 30.5 LBS (APPROX)  
 CUBE - - - - - 60.6 CU FT (APPROX)  
 GROSS WEIGHT - - - - 1,747 LBS (APPROX)

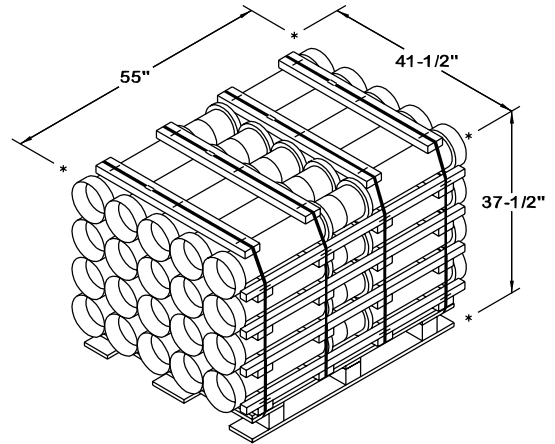

**FLAT DUNNAGE METHOD (DECREASED HEIGHT)**

CONTAINER - - - - - 40 EACH @ 30.5 LBS (APPROX)  
 CUBE - - - - - 49.5 CU FT (APPROX)  
 GROSS WEIGHT - - - - - 1,418 LBS (APPROX)

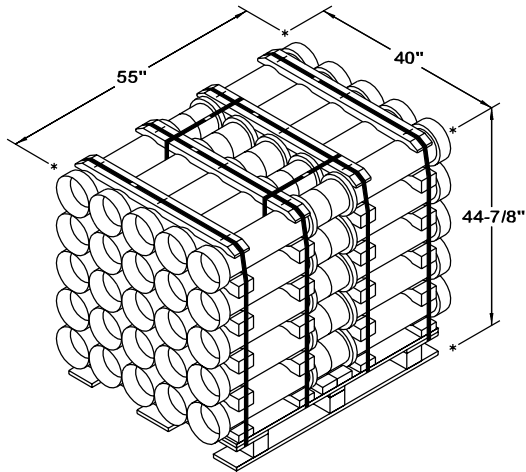

**ROUTED DUNNAGE METHOD (BASIC HEIGHT)**

CONTAINER - - - - - 50 EACH @ 30.5 LBS (APPROX)  
 CUBE - - - - - 57.1 CU FT (APPROX)  
 GROSS WEIGHT - - - - - 1,761 LBS (APPROX)

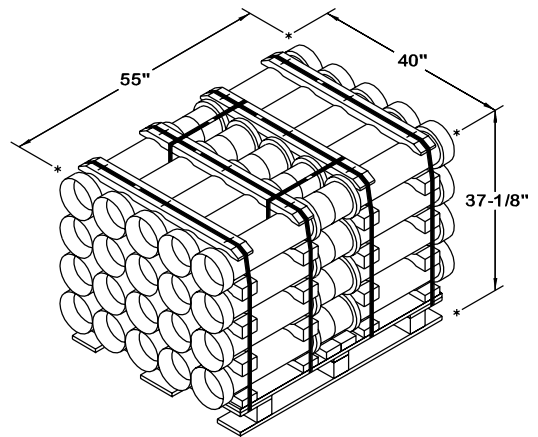

**ROUTED DUNNAGE METHOD (DECREASED HEIGHT)**

CONTAINER - - - - - 40 EACH @ 30.5 LBS (APPROX)  
 CUBE - - - - - 47.2 CU FT (APPROX)  
 GROSS WEIGHT - - - - - 1,430 LBS (APPROX)

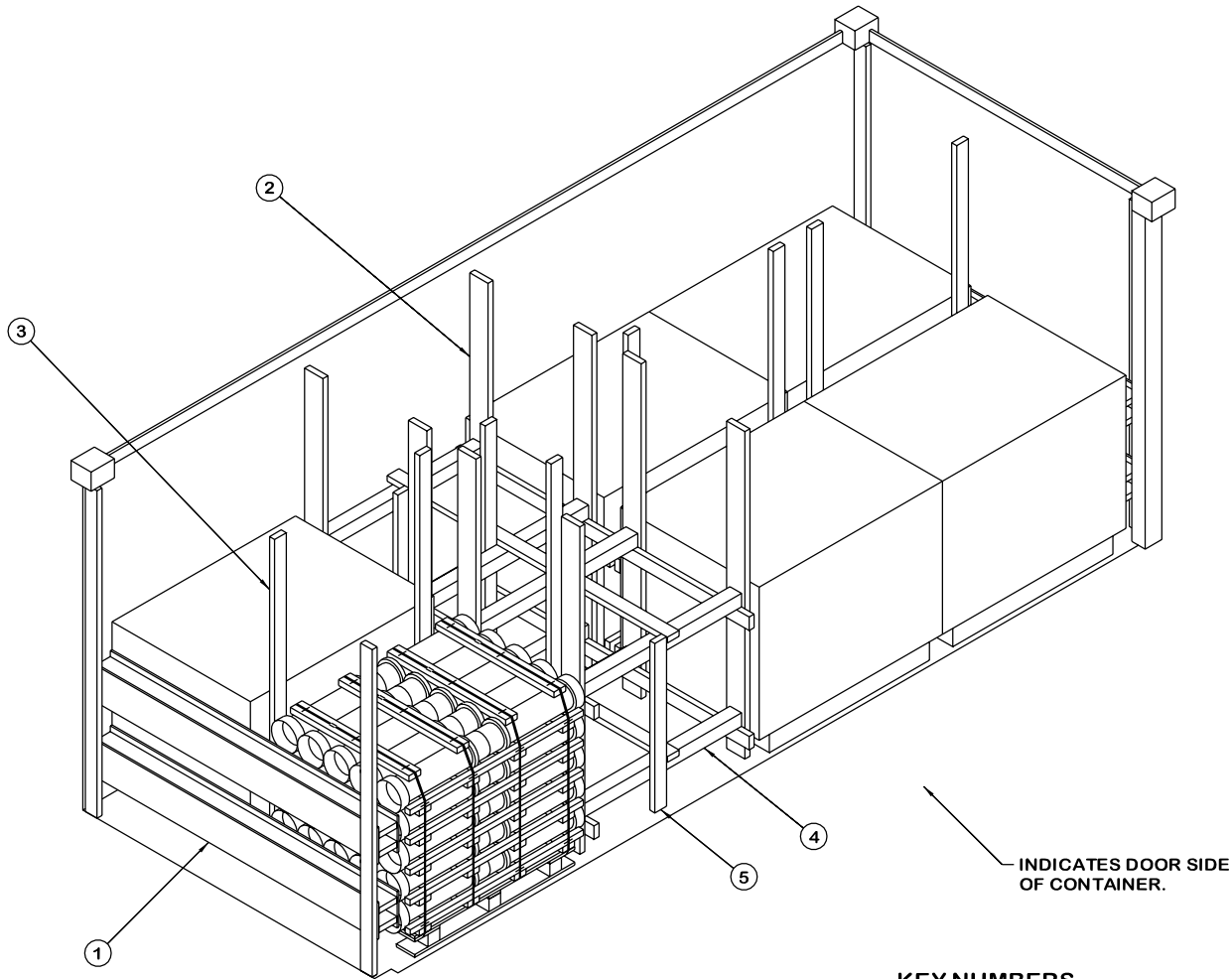

**ISOMETRIC VIEW**

**KEY NUMBERS**

- ① END BLOCKING ASSEMBLY (2 REQD). SEE DETAIL ON PAGE 12.
- ② CENTER GATE ASSEMBLY (2 REQD). SEE DETAIL ON PAGE 13.
- ③ CRIB FILL ASSEMBLY (3 REQD). SEE DETAIL ON PAGE 14.
- ④ STRUT, 4" X 4" BY CUT-TO-FIT (REF: 48") (8 REQD). TOENAIL TO THE CENTER GATE ASSEMBLY W/2-12d NAILS AT EACH END. SEE "BEVEL-CUT" ON PAGE 15.
- ⑤ STRUT BRACING (1 REQD). SEE DETAIL ON PAGE 15.

**RECOMMENDED SEQUENTIAL PROCEDURES**

1. PREFABRICATE TWO END BLOCKING ASSEMBLIES, TWO CENTER GATE ASSEMBLIES, AND THREE CRIB FILL ASSEMBLIES.
2. INSTALL ONE END BLOCKING ASSEMBLY AGAINST RIGHT SIDE END WALL AND LOAD ONE PALLET UNIT TIGHT AGAINST THE END BLOCKING ASSEMBLY AND THE FAR WALL.
3. INSTALL ONE CRIB FILL ASSEMBLY AGAINST SIDE OF PALLET UNIT AND LOAD ONE PALLET UNIT TIGHT AGAINST THE END BLOCKING ASSEMBLY AND THE CRIB FILL ASSEMBLY.
4. INSTALL ONE END BLOCKING ASSEMBLY AGAINST LEFT SIDE END WALL AND LOAD ONE PALLET UNIT TIGHT AGAINST THE END BLOCKING ASSEMBLY AND THE FAR WALL.
5. INSTALL ONE CRIB FILL ASSEMBLY AGAINST SIDE OF PALLET UNIT AND LOAD ONE PALLET UNIT TIGHT AGAINST THE END BLOCKING ASSEMBLY AND THE CRIB FILL ASSEMBLY.
6. LOAD ONE PALLET UNIT TIGHT AGAINST THE RIGHT SIDE PALLET UNITS AND THE FAR WALL.
7. INSTALL ONE CRIB FILL ASSEMBLY AGAINST SIDE OF PALLET UNIT AND LOAD ONE PALLET UNIT TIGHT AGAINST THE RIGHT SIDE PALLET UNITS AND THE CRIB FILL ASSEMBLY.
8. INSTALL TWO CENTER GATE ASSEMBLIES IN THE SPACE BETWEEN PALLET UNITS.
9. MEASURE LENGTH FOR HORIZONTAL STRUTS, CUT REQUIRED QUANTITY OF STRUTS AND STRUT BRACING, AND PLACE IN POSITION ACCORDING TO STRUT BRACING DETAIL.

BILL OF MATERIAL		
LUMBER	LINEAR FEET	BOARD FEET
2" X 4"	185	123
2" X 6"	115	115
4" X 4"	32	43
NAILS	NO. REQD	POUNDS
6d (2")	176	1
10d (3")	144	2
12d (3-1/4")	64	1
PLYWOOD, 1/2" - - - 45.36 SQ FT REQD - -		62.37 LBS

**LOAD AS SHOWN**

ITEM	QUANTITY	WEIGHT (APPROX)
PALLET UNIT - - - - -	6 - - - - -	10,482 LBS
DUNNAGE - - - - -	- - - - -	629 LBS
CONTAINER - - - - -	- - - - -	6,050 LBS
TOTAL WEIGHT - - - - -		17,161 LBS (APPROX)

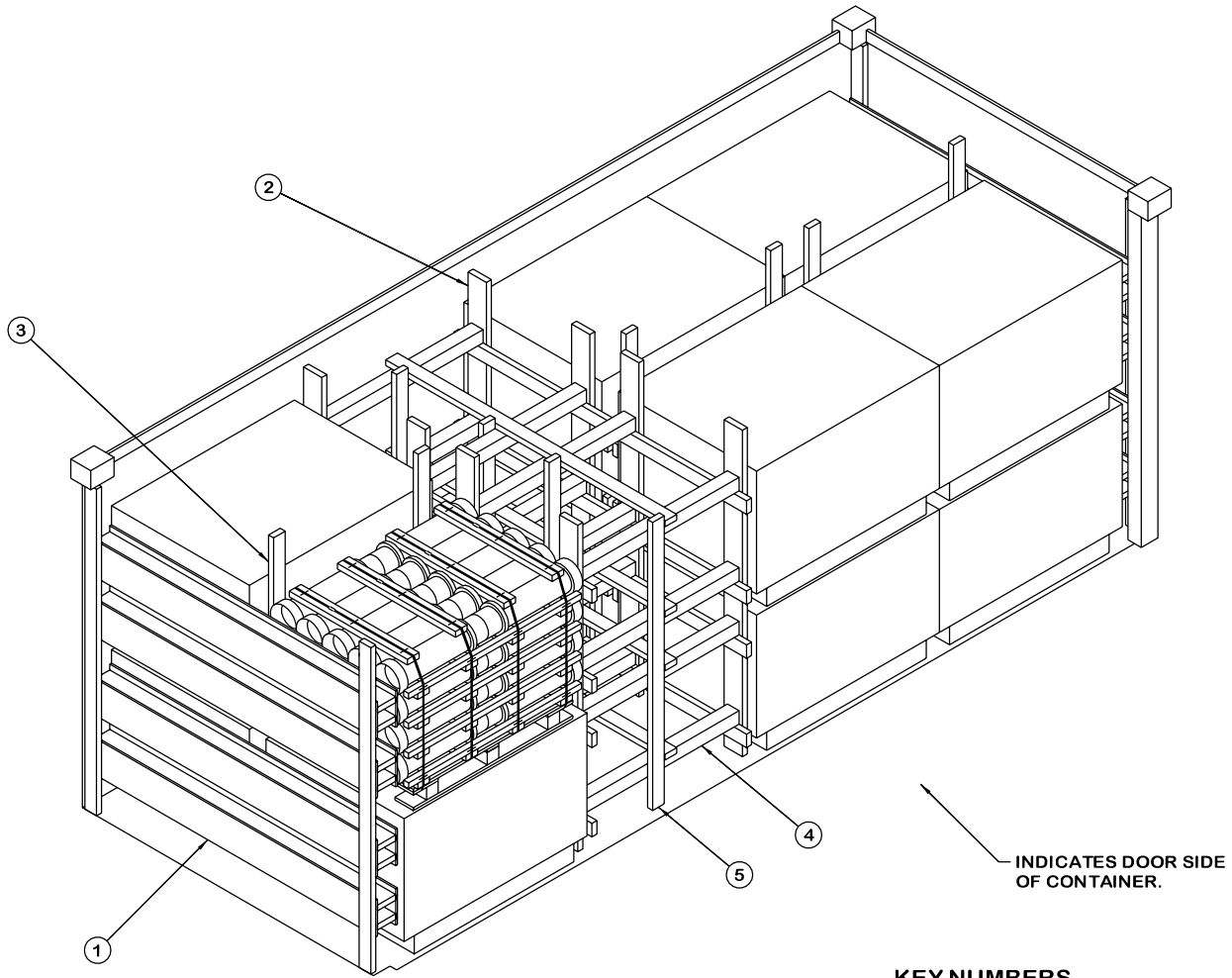

**ISOMETRIC VIEW**

**KEY NUMBERS**

- ① END BLOCKING ASSEMBLY (2 REQD). SEE DETAIL ON PAGE 12.
- ② CENTER GATE ASSEMBLY (2 REQD). SEE DETAIL ON PAGE 13.
- ③ CRIB FILL ASSEMBLY (3 REQD). SEE DETAIL ON PAGE 14.
- ④ STRUT, 4" X 4" BY CUT-TO-FIT (REF: 48") (16 REQD). TOENAIL TO THE CENTER GATE ASSEMBLY W/2-12d NAILS AT EACH END. SEE "BEVEL-CUT" ON PAGE 15.
- ⑤ STRUT BRACING (1 REQD). SEE DETAIL ON PAGE 15.

**RECOMMENDED SEQUENTIAL PROCEDURES**

1. PREFABRICATE TWO END BLOCKING ASSEMBLIES, TWO CENTER GATE ASSEMBLIES, AND THREE CRIB FILL ASSEMBLIES.
2. INSTALL ONE END BLOCKING ASSEMBLY AGAINST RIGHT SIDE END WALL AND LOAD TWO STACKED PALLET UNITS TIGHT AGAINST THE END BLOCKING ASSEMBLY AND THE FAR WALL.
3. INSTALL ONE CRIB FILL ASSEMBLY AGAINST SIDE OF PALLET UNITS AND LOAD TWO STACKED PALLET UNITS TIGHT AGAINST THE END BLOCKING ASSEMBLY AND THE CRIB FILL ASSEMBLY.
4. INSTALL ONE END BLOCKING ASSEMBLY AGAINST LEFT SIDE END WALL AND LOAD TWO STACKED PALLET UNITS TIGHT AGAINST THE END BLOCKING ASSEMBLY AND THE FAR WALL.
5. INSTALL ONE CRIB FILL ASSEMBLY AGAINST SIDE OF PALLET UNITS AND LOAD TWO STACKED PALLET UNITS TIGHT AGAINST THE END BLOCKING ASSEMBLY AND THE CRIB FILL ASSEMBLY.
6. LOAD TWO STACKED PALLET UNITS TIGHT AGAINST THE RIGHT SIDE PALLET UNITS AND THE FAR WALL.
7. INSTALL ONE CRIB FILL ASSEMBLY AGAINST SIDE OF PALLET UNITS AND LOAD TWO STACKED PALLET UNITS TIGHT AGAINST THE RIGHT SIDE PALLET UNITS AND THE CRIB FILL ASSEMBLY.
8. INSTALL TWO CENTER GATE ASSEMBLIES IN THE SPACE BETWEEN PALLET UNITS.
9. MEASURE LENGTH FOR HORIZONTAL STRUTS, CUT REQUIRED QUANTITY OF STRUTS AND STRUT BRACING, AND PLACE IN POSITION ACCORDING TO STRUT BRACING DETAIL.

NOTE: A MIXED LOAD COULD BE ASSEMBLED USING BOTH BASIC HEIGHT PALLET UNITS AND DECREASED HEIGHT PALLET UNITS. THE FIRST LAYER OF PALLET UNITS WOULD HAVE BASIC HEIGHT UNITS AND THE SECOND LAYER OF PALLET UNITS WOULD HAVE DECREASED HEIGHT UNITS. DUNNAGE ASSEMBLIES WOULD HAVE TO BE ADJUSTED ACCORDINGLY (SEE PAGES 12, 13 AND 14). TOTAL WEIGHT OF THIS NEW LOAD IS APPROXIMATELY 19,146 LBS.

BILL OF MATERIAL		
LUMBER	LINEAR FEET	BOARD FEET
2" X 4"	294	196
2" X 6"	172	172
4" X 4"	64	86
NAILS	NO. REQD	POUNDS
6d (2")	352	2
10d (3")	288	4-1/2
12d (3-1/4")	128	2
PLYWOOD, 1/2" - - - 90.72 SQ FT REQD - - 124.74 LBS		

**LOAD AS SHOWN**

ITEM	QUANTITY	WEIGHT (APPROX)
PALLET UNIT	12	17,016 LBS
DUNNAGE		1,041 LBS
CONTAINER		6,050 LBS
TOTAL WEIGHT		24,107 LBS (APPROX)

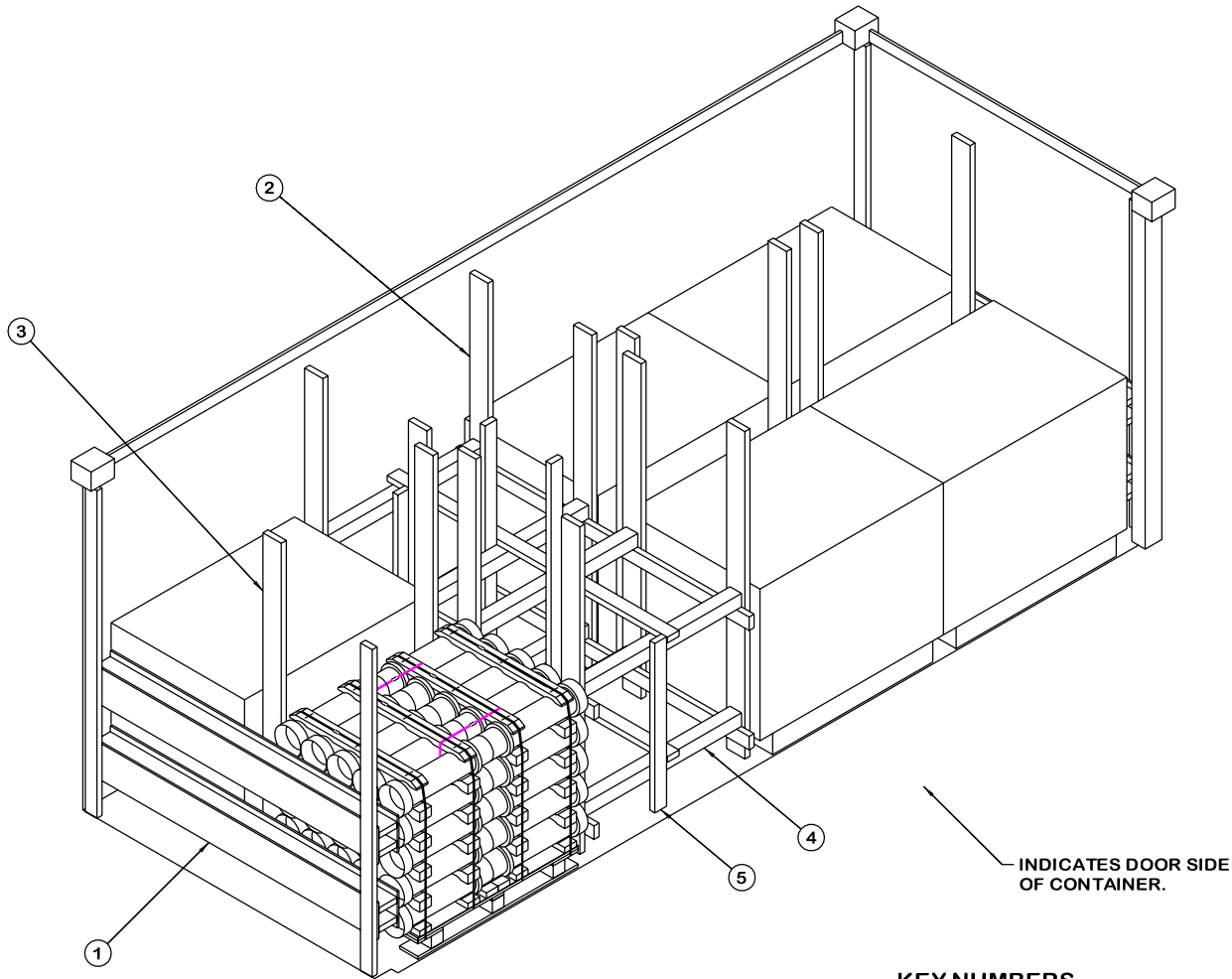

**ISOMETRIC VIEW**

**KEY NUMBERS**

- ① END BLOCKING ASSEMBLY (2 REQD). SEE DETAIL ON PAGE 12.
- ② CENTER GATE ASSEMBLY (2 REQD). SEE DETAIL ON PAGE 13.
- ③ CRIB FILL ASSEMBLY (3 REQD). SEE DETAIL ON PAGE 14.
- ④ STRUT, 4" X 4" BY CUT-TO-FIT (REF: 48") (8 REQD). TOENAIL TO THE CENTER GATE ASSEMBLY W/2-12d NAILS AT EACH END. SEE "BEVEL-CUT" ON PAGE 15.
- ⑤ STRUT BRACING (1 REQD). SEE DETAIL ON PAGE 15.



**RECOMMENDED SEQUENTIAL PROCEDURES**

1. PREFABRICATE TWO END BLOCKING ASSEMBLIES, TWO CENTER GATE ASSEMBLIES, AND THREE CRIB FILL ASSEMBLIES.
2. INSTALL ONE END BLOCKING ASSEMBLY AGAINST RIGHT SIDE END WALL AND LOAD ONE PALLET UNIT TIGHT AGAINST THE END BLOCKING ASSEMBLY AND THE FAR WALL.
3. INSTALL ONE CRIB FILL ASSEMBLY AGAINST SIDE OF PALLET UNIT AND LOAD ONE PALLET UNIT TIGHT AGAINST THE END BLOCKING ASSEMBLY AND THE CRIB FILL ASSEMBLY.
4. INSTALL ONE END BLOCKING ASSEMBLY AGAINST LEFT SIDE END WALL AND LOAD ONE PALLET UNIT TIGHT AGAINST THE END BLOCKING ASSEMBLY AND THE FAR WALL.
5. INSTALL ONE CRIB FILL ASSEMBLY AGAINST SIDE OF PALLET UNIT AND LOAD ONE PALLET UNIT TIGHT AGAINST THE END BLOCKING ASSEMBLY AND THE CRIB FILL ASSEMBLY.
6. LOAD ONE PALLET UNIT TIGHT AGAINST THE RIGHT SIDE PALLET UNITS AND THE FAR WALL.
7. INSTALL ONE CRIB FILL ASSEMBLY AGAINST SIDE OF PALLET UNIT AND LOAD ONE PALLET UNIT TIGHT AGAINST THE RIGHT SIDE PALLET UNITS AND THE CRIB FILL ASSEMBLY.
8. INSTALL TWO CENTER GATE ASSEMBLIES IN THE SPACE BETWEEN PALLET UNITS.
9. MEASURE LENGTH FOR HORIZONTAL STRUTS, CUT REQUIRED QUANTITY OF STRUTS AND STRUT BRACING, AND PLACE IN POSITION ACCORDING TO STRUT BRACING DETAIL.

BILL OF MATERIAL		
LUMBER	LINEAR FEET	BOARD FEET
2" X 4"	142	95
2" X 6"	159	159
4" X 4"	32	43
NAILS	NO. REQD	POUNDS
6d (2")	176	1
10d (3")	144	2-1/2
12d (3-1/4")	64	1
PLYWOOD, 1/2" - - - 45.36 SQ FT REQD - - 62.37 LBS		

**LOAD AS SHOWN**

ITEM	QUANTITY	WEIGHT (APPROX)
PALLET UNIT	6	10,566 LBS
DUNNAGE		661 LBS
CONTAINER		6,050 LBS
TOTAL WEIGHT		17,277 LBS (APPROX)

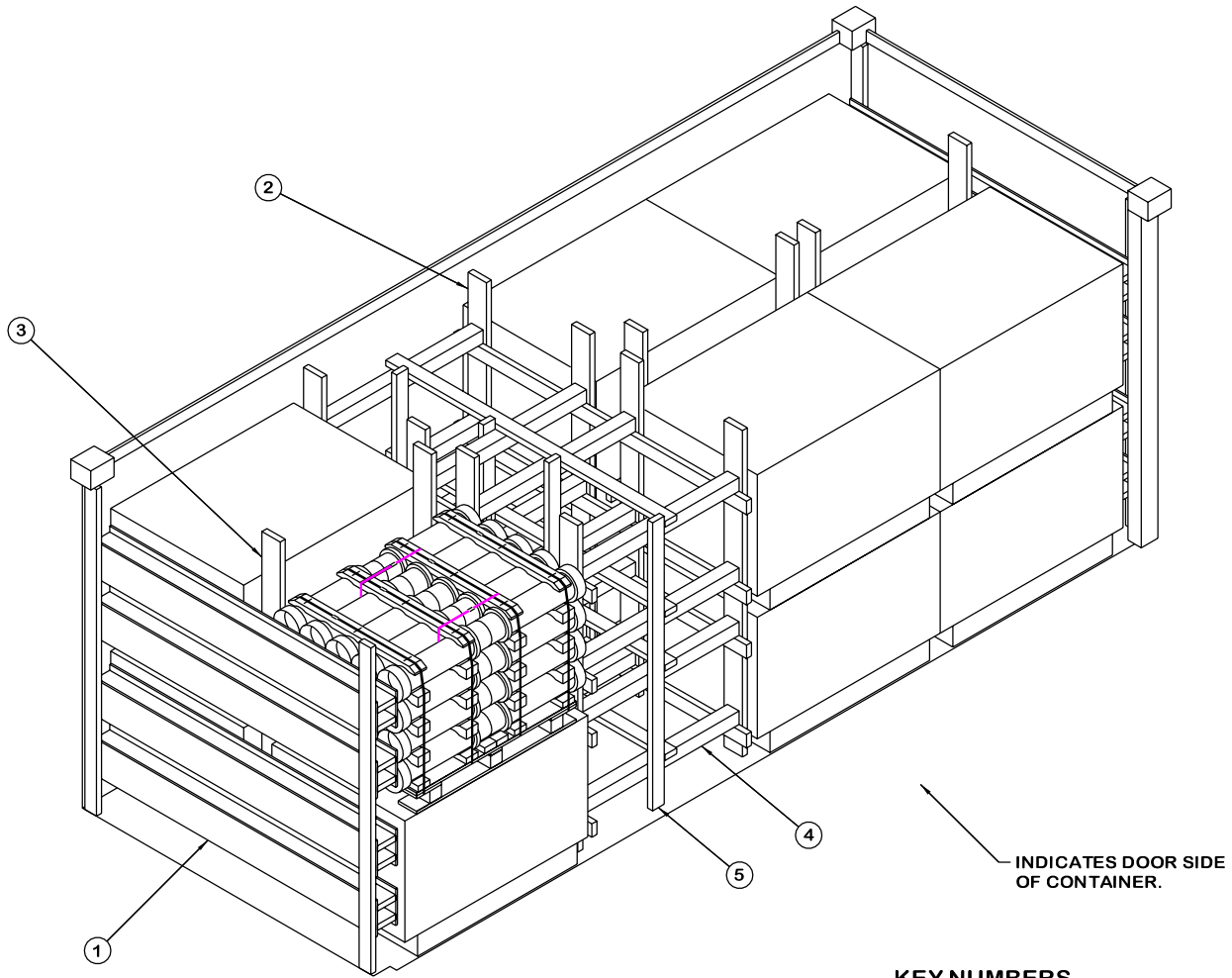

**ISOMETRIC VIEW**

**KEY NUMBERS**

- ① END BLOCKING ASSEMBLY (2 REQD). SEE DETAIL ON PAGE 12.
- ② CENTER GATE ASSEMBLY (2 REQD). SEE DETAIL ON PAGE 13.
- ③ CRIB FILL ASSEMBLY (3 REQD). SEE DETAIL ON PAGE 14.
- ④ STRUT, 4" X 4" BY CUT-TO-FIT (REF: 48") (16 REQD). TOENAIL TO THE CENTER GATE ASSEMBLY W/2-12d NAILS AT EACH END. SEE "BEVEL-CUT" ON PAGE 15.
- ⑤ STRUT BRACING (1 REQD). SEE DETAIL ON PAGE 15.

**RECOMMENDED SEQUENTIAL PROCEDURES**

1. PREFABRICATE TWO END BLOCKING ASSEMBLIES, TWO CENTER GATE ASSEMBLIES, AND THREE CRIB FILL ASSEMBLIES.
2. INSTALL ONE END BLOCKING ASSEMBLY AGAINST RIGHT SIDE END WALL AND LOAD TWO STACKED PALLET UNITS TIGHT AGAINST THE END BLOCKING ASSEMBLY AND THE FAR WALL.
3. INSTALL ONE CRIB FILL ASSEMBLY AGAINST SIDE OF PALLET UNITS AND LOAD TWO STACKED PALLET UNITS TIGHT AGAINST THE END BLOCKING ASSEMBLY AND THE CRIB FILL ASSEMBLY.
4. INSTALL ONE END BLOCKING ASSEMBLY AGAINST LEFT SIDE END WALL AND LOAD TWO STACKED PALLET UNITS TIGHT AGAINST THE END BLOCKING ASSEMBLY AND THE FAR WALL.
5. INSTALL ONE CRIB FILL ASSEMBLY AGAINST SIDE OF PALLET UNITS AND LOAD TWO STACKED PALLET UNITS TIGHT AGAINST THE END BLOCKING ASSEMBLY AND THE CRIB FILL ASSEMBLY.
6. LOAD TWO STACKED PALLET UNITS TIGHT AGAINST THE RIGHT SIDE PALLET UNITS AND THE FAR WALL.
7. INSTALL ONE CRIB FILL ASSEMBLY AGAINST SIDE OF PALLET UNITS AND LOAD TWO STACKED PALLET UNITS TIGHT AGAINST THE RIGHT SIDE PALLET UNITS AND THE CRIB FILL ASSEMBLY.
8. INSTALL TWO CENTER GATE ASSEMBLIES IN THE SPACE BETWEEN PALLET UNITS.
9. MEASURE LENGTH FOR HORIZONTAL STRUTS, CUT REQUIRED QUANTITY OF STRUTS AND STRUT BRACING, AND PLACE IN POSITION ACCORDING TO STRUT BRACING DETAIL.

NOTE: A MIXED LOAD COULD BE ASSEMBLED USING BOTH BASIC HEIGHT PALLET UNITS AND DECREASED HEIGHT PALLET UNITS. THE FIRST LAYER OF PALLET UNITS WOULD HAVE BASIC HEIGHT UNITS AND THE SECOND LAYER OF PALLET UNITS WOULD HAVE DECREASED HEIGHT UNITS. DUNNAGE ASSEMBLIES WOULD HAVE TO BE ADJUSTED ACCORDINGLY (SEE PAGES 12, 13 AND 14). TOTAL WEIGHT OF THIS NEW LOAD IS APPROXIMATELY 19,146 LBS.

BILL OF MATERIAL		
LUMBER	LINEAR FEET	BOARD FEET
2" X 4"	250	167
2" X 6"	216	216
4" X 4"	64	86
NAILS	NO. REQD	POUNDS
6d (2")	352	2
10d (3")	288	4-1/2
12d (3-1/4")	128	2
PLYWOOD, 1/2" - - - 90.72 SQ FT REQD - - 124.74 LBS		

**LOAD AS SHOWN**

ITEM	QUANTITY	WEIGHT (APPROX)
PALLET UNIT	12	17,160 LBS
DUNNAGE		1,072 LBS
CONTAINER		6,050 LBS
TOTAL WEIGHT		24,282 LBS (APPROX)

SEE GENERAL NOTE "G" ON PAGE 2.

BUFFER PIECE, 2" X 4" BY INSIDE CONTAINER HEIGHT MINUS 1" (REF: 7'-1") (2 REQD). NAIL THROUGH PLYWOOD INTO THE BEAMS W/2-10d NAILS AT EACH JOINT.

BEAM, 2" X 6" BY INSIDE CONTAINER WIDTH MINUS 1" (REF: 7'-2") (8 REQD).

PLYWOOD, 1/2" X 9-1/2" BY INSIDE CONTAINER WIDTH MINUS 1" (REF: 7'-2") (8 REQD). NAIL TO THE BEAMS W/1-6d NAIL EVERY 8".

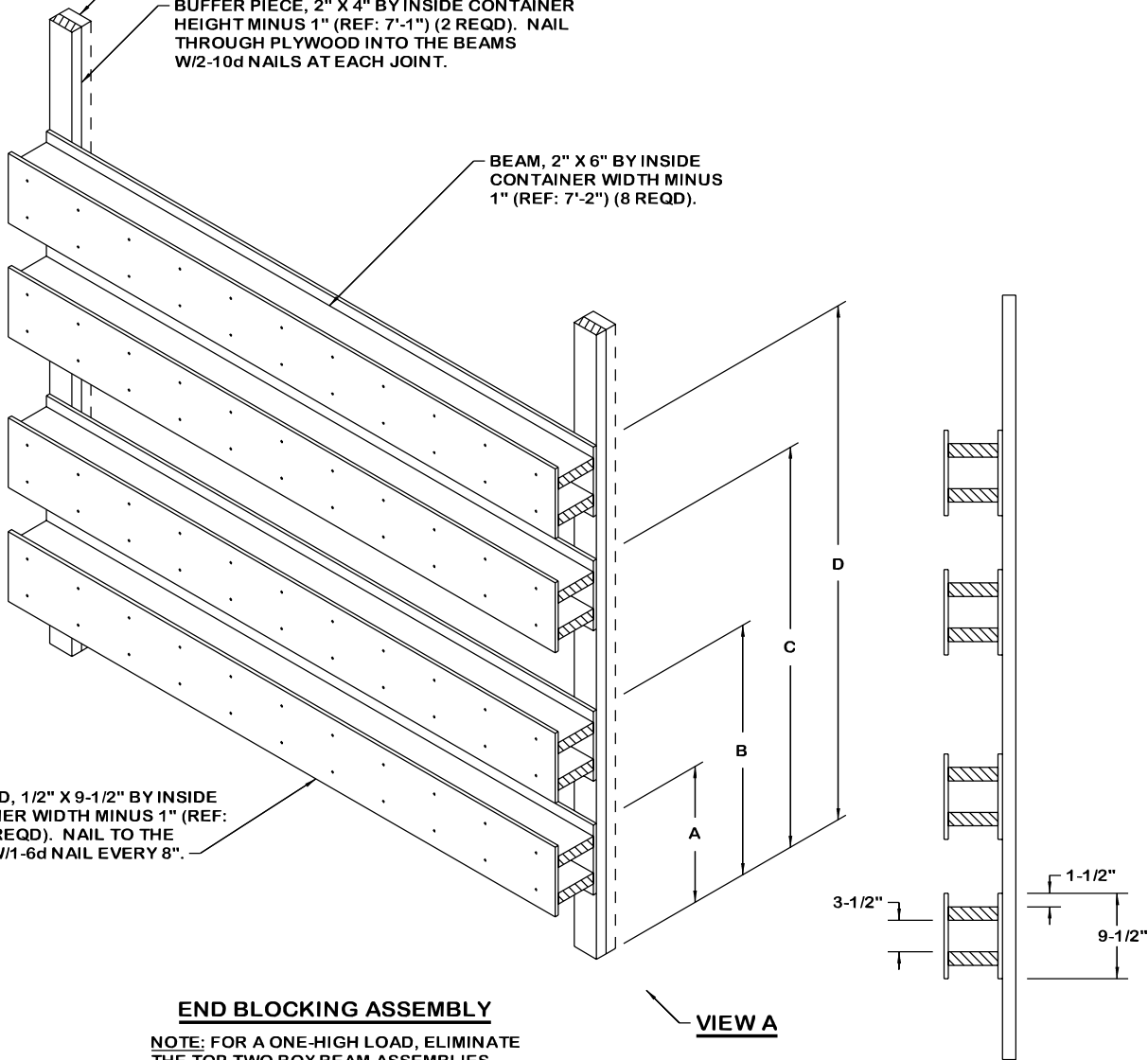

**END BLOCKING ASSEMBLY**

NOTE: FOR A ONE-HIGH LOAD, ELIMINATE THE TOP TWO BOX BEAM ASSEMBLIES.

**VIEW A**

**VIEW A**

**END BLOCKING CHART**

PALLET UNIT	DIMENSION			
	A	B	C	D
FLAT (BASIC)	18-1/2"	38"	- -	- -
FLAT (DECREASED)	18-1/2"	34"	54-1/2"	70"
ROUTED (BASIC)	18-1/2"	38"	- -	- -
ROUTED (DECREASED)	18-1/2"	34"	54-1/2"	70"

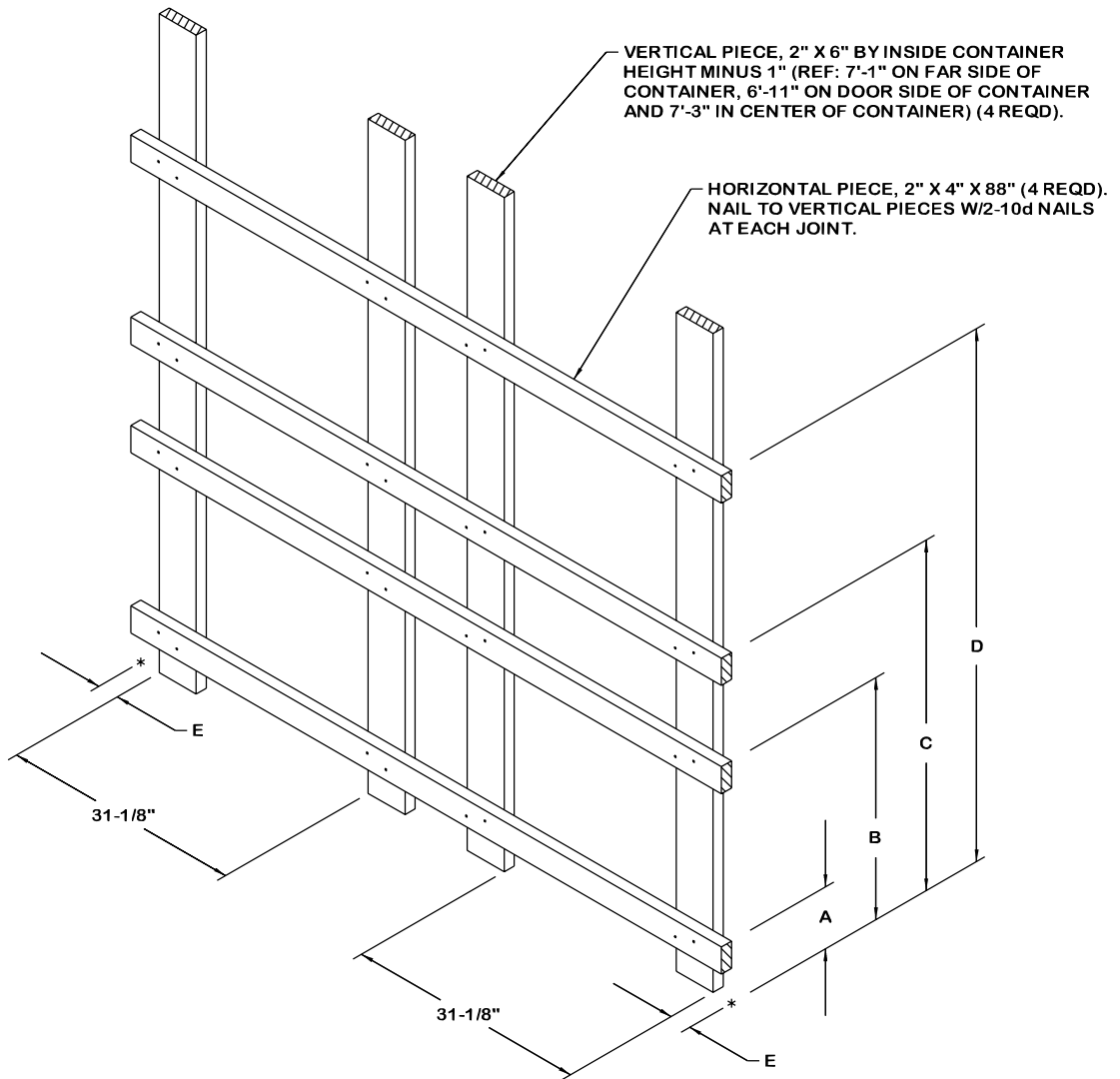

**CENTER GATE ASSEMBLY**

**NOTE: FOR A ONE-HIGH LOAD, ELIMINATE THE TOP TWO HORIZONTAL PIECES.**

CENTER GATE CHART					
PALLET UNIT	DIMENSION				
	A	B	C	D	E
FLAT (BASIC)	8"	39"	--	--	2-3/4"
FLAT (DECREASED)	8"	31-1/4"	45-1/4"	68-3/4"	2-3/4"
ROUTED (BASIC)	8"	39"	--	--	1-1/4"
ROUTED (DECREASED)	8"	31-1/4"	45-1/4"	68-3/4"	1-1/4"

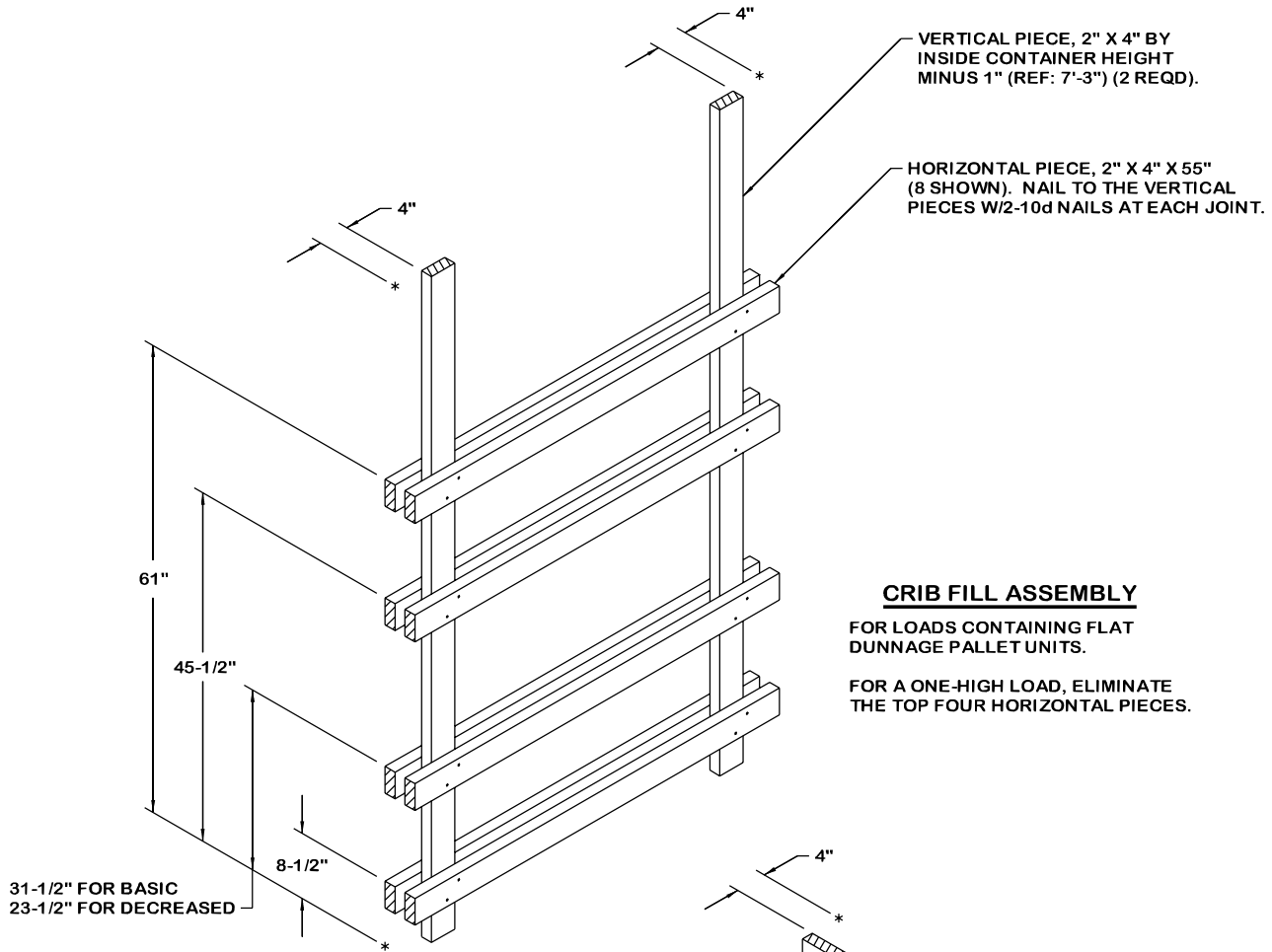

**CRIB FILL ASSEMBLY**

FOR LOADS CONTAINING FLAT DUNNAGE PALLET UNITS.

FOR A ONE-HIGH LOAD, ELIMINATE THE TOP FOUR HORIZONTAL PIECES.

31-1/2" FOR BASIC  
23-1/2" FOR DECREASED

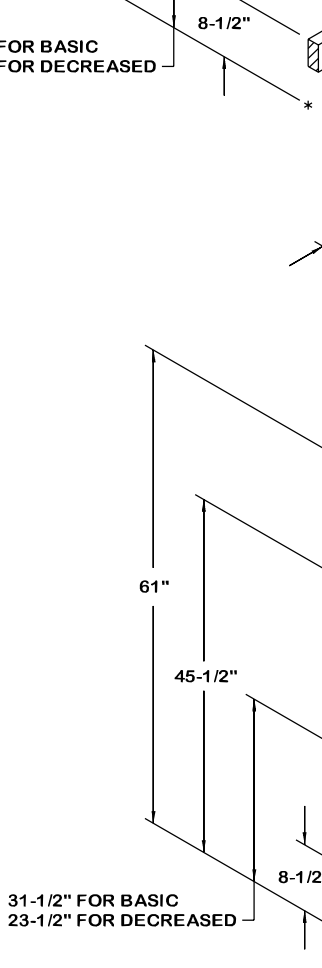

**CRIB FILL ASSEMBLY**

FOR LOADS CONTAINING ROUTED DUNNAGE PALLET UNITS.

FOR A ONE-HIGH LOAD, ELIMINATE THE TOP FOUR HORIZONTAL PIECES.

31-1/2" FOR BASIC  
23-1/2" FOR DECREASED

**NOTE: STRUT BRACING REQUIRED FOR STRUTS 48" OR LONGER.**  
 (REF: DRAWING 19-48-4267-15PA1009, PAGE 3, GENERAL NOTE "U").

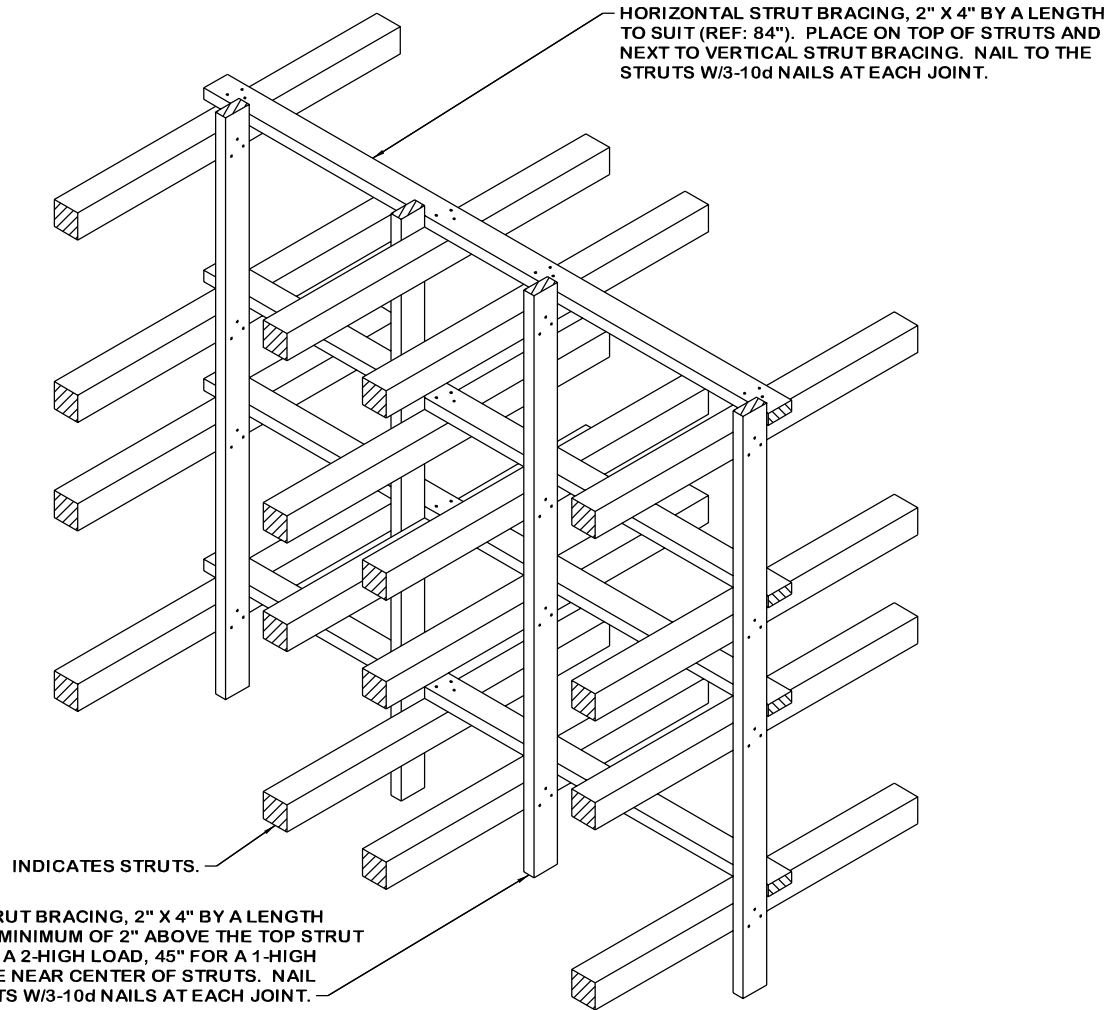

**TYPICAL STRUT BRACING**

THE STRUT BRACING SHOWN IS FOR A 2-HIGH LOAD.  
 THE PROCEDURE MAY BE ADAPTED FOR USE IN A 1-HIGH LOAD.

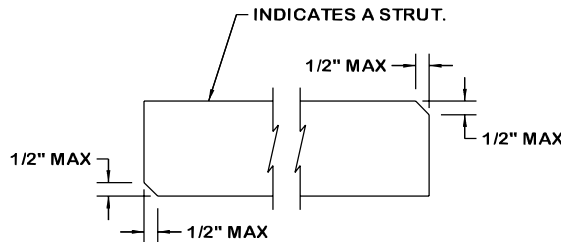

**BEVEL-CUT**

IF DESIRED, EACH END OF A STRUT MAY BE BEVEL-CUT AS SHOWN ABOVE TO FACILITATE THE ACHIEVEMENT OF A TIGHT CENTER-GATE-TO-CENTER-GATE FIT.

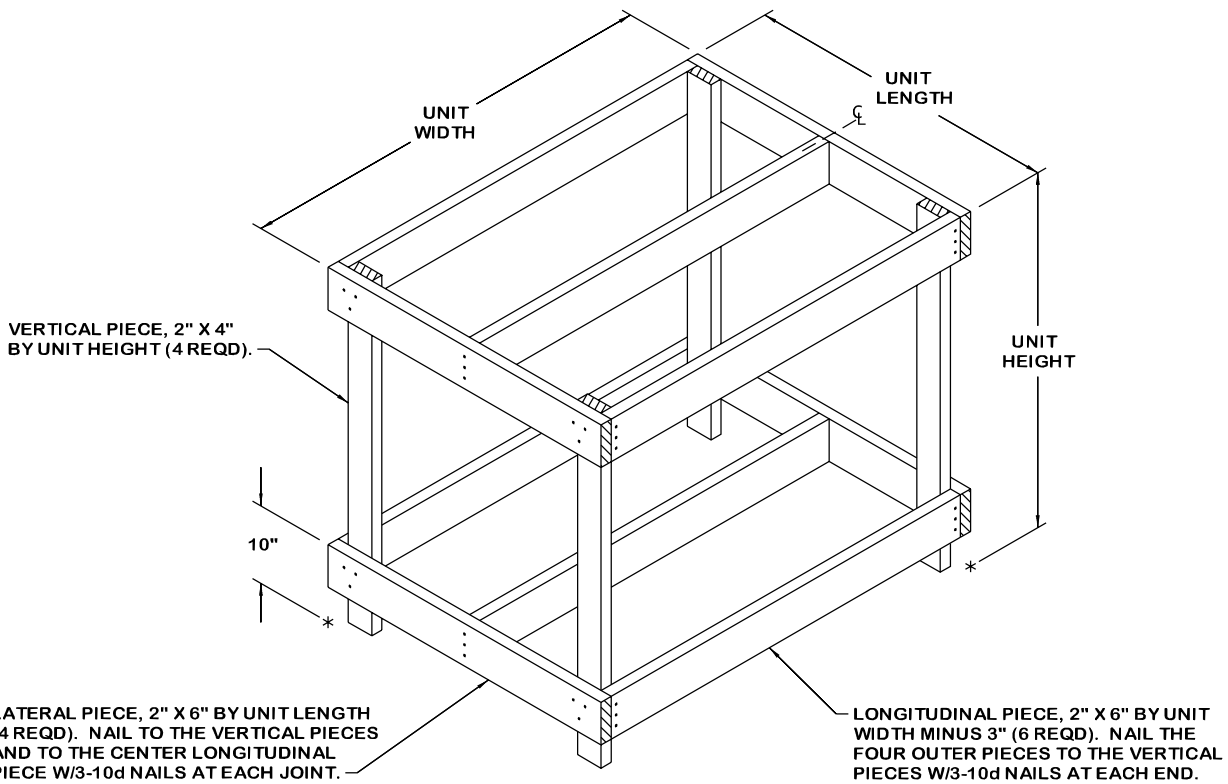

**OMITTED UNIT ASSEMBLY**

THIS ASSEMBLY IS FOR USE IN PLACE OF AN OMITTED PALLET UNIT. NO MORE THAN THREE OMITTED UNIT ASSEMBLIES MAY BE USED PER TWO-HIGH LOAD, AND NO MORE THAN ONE OMITTED UNIT ASSEMBLY MAY BE USED PER ONE-HIGH LOAD. DO NOT INSTALL AN OMITTED UNIT ASSEMBLY IMMEDIATELY ADJACENT TO ANOTHER OMITTED UNIT ASSEMBLY.