





LOADING AND BRACING (TL & LTL) ON FLATBED TRAILERS OF CBU ITEMS PACKED IN CNU-147/E TWIN PACK CONTAINERS

INDEX

<u>ITEM</u>	<u>PAGE(S)</u>
GENERAL NOTES AND MATERIAL SPECIFICATIONS - - - - -	2
CONTAINER DETAIL - - - - -	3
22-UNIT LOAD ON A 40'-0" LONG BY 8'-0" WIDE FLATBED TRAILER (STEEL STRAP TIEDOWN METHOD) - - - - -	4, 5
22-UNIT LOAD ON A 45'-0" LONG BY 8'-0" WIDE FLATBED TRAILER (STEEL STRAP TIEDOWN METHOD) - - - - -	6, 7
22-UNIT LOAD ON A 48'-0" LONG BY 8'-0" WIDE FLATBED TRAILER (STEEL STRAP TIEDOWN METHOD) - - - - -	8, 9
22-UNIT LOAD ON A 40'-0" LONG BY 8'-0" WIDE FLATBED TRAILER (CHAIN TIEDOWN METHOD) - - - - -	10, 11
22-UNIT LOAD ON A 45'-0" LONG BY 8'-0" WIDE FLATBED TRAILER (WEB STRAP TIEDOWN METHOD) - - - - -	12, 13
TYPICAL LTL (2-UNIT LOAD) - - - - -	14
DETAILS - - - - -	15
PROVISIONS FOR THE USE OF FIREHOSE - - - - -	16

● **CAUTION:** THE OUTLOADING PROCEDURES SHOWN HEREIN ARE ONLY APPLICABLE TO HIGHWAY MOVEMENTS, NOT TRAILER-ON-FLATCAR (TOFC) MOVEMENTS.

U.S. ARMY MATERIEL COMMAND DRAWING

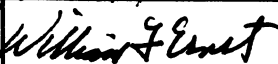
APPROVED, U.S. ARMY INDUSTRIAL OPERATIONS COMMAND 		ENGINEER BASIC REV. MICHAEL SARDONE TECHNICIAN BASIC REV. PATTY BRIGHT DRAFTSMAN BASIC REV. GREGORY GUAY	DO NOT SCALE WEBSITE: HTTP://WWW.DAC.ARMY.MIL MARCH 1992 REVISION NO. 1 JANUARY 1997									
APPROVED BY ORDER OF COMMANDING GENERAL, U.S. ARMY MATERIEL COMMAND  DEFENSE AMMUNITION CENTER		TRANSPORTATION ENGINEERING DIVISION  VALIDATION ENGINEERING DIVISION  LOGISTICS ENGINEERING OFFICE 	SEE THE REVISION LISTING ON PAGE 2 <table border="1" style="width: 100%; border-collapse: collapse;"> <tr> <td style="width: 15%;">CLASS</td> <td style="width: 15%;">DIVISION</td> <td style="width: 15%;">DRAWING</td> <td style="width: 15%;">FILE</td> </tr> <tr> <td style="text-align: center;">19</td> <td style="text-align: center;">48</td> <td style="text-align: center;">4258</td> <td style="text-align: center;">11A1006</td> </tr> </table>		CLASS	DIVISION	DRAWING	FILE	19	48	4258	11A1006
CLASS	DIVISION	DRAWING	FILE									
19	48	4258	11A1006									

GENERAL NOTES

(GENERAL NOTES CONTINUED)

- A. THIS DOCUMENT HAS BEEN PREPARED AND ISSUED IN ACCORDANCE WITH AR 740-1, AND AUGMENTS TM 743-200-1 (CHAPTER 5).
- B. THE OUTLOADING PROCEDURES SPECIFIED IN THIS DRAWING ARE APPLICABLE TO CBU ITEMS WHEN THEY ARE PACKAGED IN THE CNU-147/E TWIN PACK CONTAINER. SUBSEQUENT REFERENCE TO CONTAINER HEREIN MEANS THE TWIN PACK CONTAINER WITH CONTENTS. SEE PAGE 3 FOR DETAIL OF THE CONTAINER. SEE GENERAL NOTE "P".
- C. THE LOADS AS SHOWN HEREIN ARE BASED ON 40'-0" LONG BY 8'-0" WIDE, 45'-0" LONG BY 8'-0" WIDE, AND 48'-0" LONG BY 8'-0" WIDE FLATBED TRAILERS. TRAILERS OF OTHER LENGTH AND WIDTHS MAY BE USED. TRAILERS MUST HAVE WOOD OR WOOD AND METAL FLOORS. TRAILERS HAVING ALL-METAL FLOORS CANNOT BE USED. **CAUTION:** IF THE TRAILER FLOOR IS EQUIPPED WITH EXPOSED METAL DECKING ABOVE THE BOGIE ASSEMBLY, OR ELSEWHERE, FIELD MEASUREMENTS SHOULD BE MADE TO ENSURE THAT THE METAL DECKING DOES NOT INTERFERE WITH THE PROPER POSITIONING AND NAILING OF THE DUNNAGE AS SPECIFIED BY THE PROCEDURES SHOWN HEREIN.
- D. SELECTION OF A VEHICLE USED TO TRANSPORT THE DESIGNATED ITEM MUST COMPLY WITH AR 55-355, CHAPTER 29, FOR EXPLOSIVES AND OTHER DANGEROUS ARTICLES, IN FULL.
- E. GROSS WEIGHT AND AXLE DISTRIBUTION OF WEIGHT FOR A LOAD WILL BE THE RESPONSIBILITY OF THE CARRIER. THE CARRIER WILL ADVISE THE SHIPPER OF APPLICABLE LOADING REQUIREMENTS, AND THE SHIPPER WILL LOAD ACCORDINGLY.
- F. **NOTICE:** A SHIPMENT WILL BE POSITIONED ON A TRAILER CONSISTENT WITH STATE WEIGHT LAWS.
- G. OTHER TYPES OF LADING ITEMS MAY BE LOADED ON A TRAILER WHICH IS PARTIALLY LOADED WITH THE DESIGNATED ITEM, PROVIDING THE TOTAL LOAD IS COMPATIBLE, EXISTING DIRECTIVES ARE NOT VIOLATED, AND THE OTHER LADING ITEMS ARE BLOCKED AND BRACED TO EQUAL THE BLOCKING AND BRACING CRITERIA SPECIFIED HEREIN.
- H. **CAUTION:** REGARDLESS OF THE TYPE OF TRAILER INVOLVED, ONLY THOSE TRAILERS HAVING TIEDOWN ANCHORING FACILITIES WHICH PROVIDE HOLDING STRENGTH EQUAL TO OR GREATER THAN THE STRENGTH OF THE HOLD-DOWN STRAPS OR CHAINS AND WHICH ALIGN NEAR THE INDICATED LOCATIONS FOR THE HOLD-DOWN STRAPS OR CHAINS SHOULD BE USED. IF THE TRAILER ANCHOR DEVICES ARE NOT PROPERLY POSITIONED TO RECEIVE STRAPPING OR CHAINS, AS SHOWN, OR IF THE ANCHOR DEVICES ARE NOT EQUAL TO OR GREATER THAN THE STRENGTH OF THE TIEDOWN STRAPS OR CHAINS, STEEL STRAPS MAY BE APPLIED TO FORM A COMPLETE LOOP WHICH ENCOMPASSES BOTH THE LADING AND THE TRAILER FRAME AND/OR BED. **CAUTION:** AVOID TRAILER WHEELS, FIFTH WHEEL PLATE CONTROLS AND OTHER APPURTENANCES. USE EDGE PROTECTORS OR PADS ON ALL SHARP EDGES. NEITHER CHAINS NOR WEB STRAPS WILL BE APPLIED TO FORM A COMPLETE LOOP WHICH ENCOMPASSES BOTH THE LADING AND THE TRAILER FRAME AND/OR BED.
- J. A STAGGERED NAILING PATTERN WILL BE USED WHEREVER POSSIBLE WHEN NAILS ARE DRIVEN INTO JOINTS OF DUNNAGE ASSEMBLIES. ALSO, A STAGGERED NAILING PATTERN WILL BE USED WHEN DUNNAGE IS NAILED TO THE FLOOR OF THE TRANSPORTING VEHICLE, OR WHEN LAMINATING DUNNAGE. THE NAILING PATTERN WILL BE ADJUSTED AS REQUIRED SO THAT A NAIL DOES NOT PENETRATE INTO OR NEAR A CRACK BETWEEN FLOOR BOARDS. ADDITIONALLY, THE NAILING PATTERN FOR AN UPPER PIECE OF LAMINATED DUNNAGE WILL BE ADJUSTED AS REQUIRED SO THAT A NAIL FOR THAT PIECE WILL NOT BE DRIVEN THROUGH THE PIECE ONTO OR RIGHT BESIDE A NAIL IN A LOWER PIECE.
- K. WHEN STEEL STRAPPING IS SEALED AT AN END-OVER-END LAP JOINT, A MINIMUM OF ONE SEAL WITH TWO PAIR OF NOTCHES WILL BE USED TO SEAL THE JOINT WHEN A NOTCH-TYPE SEALER IS BEING USED. A MINIMUM OF TWO SEALS, BUTTED TOGETHER WITH TWO PAIR OF CRIMPS PER SEAL WILL BE USED TO SEAL THE JOINT WHEN A CRIMP-TYPE SEALER IS BEING USED. REFER TO THE "STRAP JOINT A" AND "STRAP JOINT B" DETAILS ON PAGE 15 FOR GUIDANCE.
- L. THE TRANSPORTING VEHICLE OPERATOR SHOULD BE INSTRUCTED TO PERIODICALLY INSPECT THE TIEDOWN CHAINS AND LOAD BINDERS DURING TRANSIT AND TIGHTEN IF NECESSARY.
- M. THE NUMBER OF LADING UNITS MAY BE ADJUSTED TO FIT THE SIZE OF THE TRAILER TO BE LOADED OR THE QUANTITY TO BE SHIPPED. THE APPROVED METHODS SHOWN HEREIN MUST BE FOLLOWED AS CLOSELY AS POSSIBLE FOR BLOCKING, BRACING AND STAYING OF THE DESIGNATED ITEM.
- N. DUNNAGE LUMBER SPECIFIED IS OF NOMINAL SIZE. FOR EXAMPLE, 1" X 4" MATERIAL IS ACTUALLY 3/4" THICK BY 3-1/2" WIDE AND 2" X 6" MATERIAL IS ACTUALLY 1-1/2" THICK BY 5-1/2" WIDE.
- O. CONVERSION TO METRIC EQUIVALENTS: DIMENSIONS WITHIN THIS DOCUMENT ARE EXPRESSED IN INCHES, AND WEIGHTS ARE EXPRESSED IN POUNDS. WHEN NECESSARY, THE METRIC EQUIVALENTS MAY BE COMPUTED ON THE BASIS OF ONE INCH EQUALS 25.4MM, AND ONE POUND EQUALS 0.454 KG.
- P. THE OUTLOADING PROCEDURES AS SHOWN ARE BASED ON THE 27" HIGH WIREBOUND WRAP-AROUND CONTAINER. HOWEVER, THE PROCEDURES ARE ALSO APPLICABLE TO THE PLYWOOD TWIN PACK CONTAINERS WHICH ARE SLIGHTLY LESS IN HEIGHT (APPROXIMATELY 1-3/4"). FOR GUIDANCE PERTINENT TO OUTLOADING PROCEDURES FOR THE PLYWOOD TWIN PACK CONTAINERS, SEE SPECIAL NOTE 3 ON PAGE 5.
- Q. FOR ADDITIONAL GUIDANCE, ATTENTION IS DIRECTED TO THE "SPECIAL NOTES" SECTION WHICH IS IMMEDIATELY ADJACENT TO A DEPICTED OUTLOADING METHOD.

(CONTINUED AT RIGHT)

MATERIAL SPECIFICATIONS

<u>LUMBER</u>	SEE TM 743-200-1 (DUNNAGE LUMBER) AND FED SPEC MM-L-751.
<u>NAILS</u>	FED SPEC FF-N-105; COMMON.
<u>STRAP, WEB</u>	WEB SLING AND TIEDOWN ASSOCIATION RECOMMENDED STANDARD SPECIFICATION FOR SYNTHETIC WEB TIEDOWNS, FIRST PUBLISHED IN 1991.
<u>STRAPPING, STEEL</u>	ASTM D3953; FLAT STRAPPING, TYPE 1, HEAVY DUTY, FINISH A, B (GRADE 2), OR C.
<u>SEAL, STRAP</u>	ASTM D3953; CLASS H, FINISH A, B (GRADE 2), OR C, DOUBLE NOTCH TYPE, STYLE I, II, OR IV.
<u>STAPLE, STRAP</u>	COMMERCIAL GRADE.
<u>STAKE POCKET PROTECTOR</u>	COMMERCIAL GRADE.
<u>CHAIN</u>	NATIONAL ASSOCIATION OF CHAIN MANUFACTURER'S WELDED CHAIN SPECIFICATION ADOPTED NOVEMBER 1975.
<u>LOAD BINDER</u>	FED SPEC GGG-B-325.

REVISION

REVISION NO. 1 DATED JANUARY 1997, CONSISTS OF:

1. MODIFYING SIDE BLOCKING AND HEADERS.
2. INCLUDING LOAD FOR A 48'-0" LONG TRAILER.
3. ADDING WEB STRAP TIEDOWN METHOD.
4. UPDATING GENERAL NOTES AND DRAWING FORMAT.

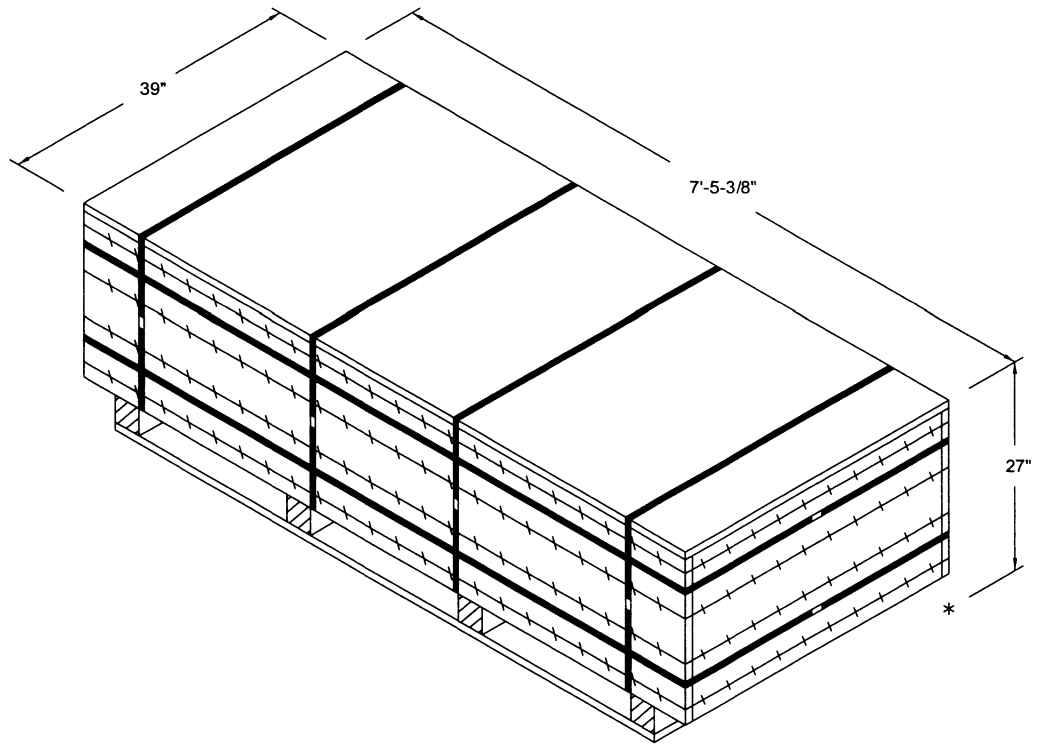

CNU-147/E CONTAINER

GROSS WEIGHT ----- 1,855 POUNDS MAXIMUM (APPROX)
CUBE ----- 53.9 CUBIC FEET

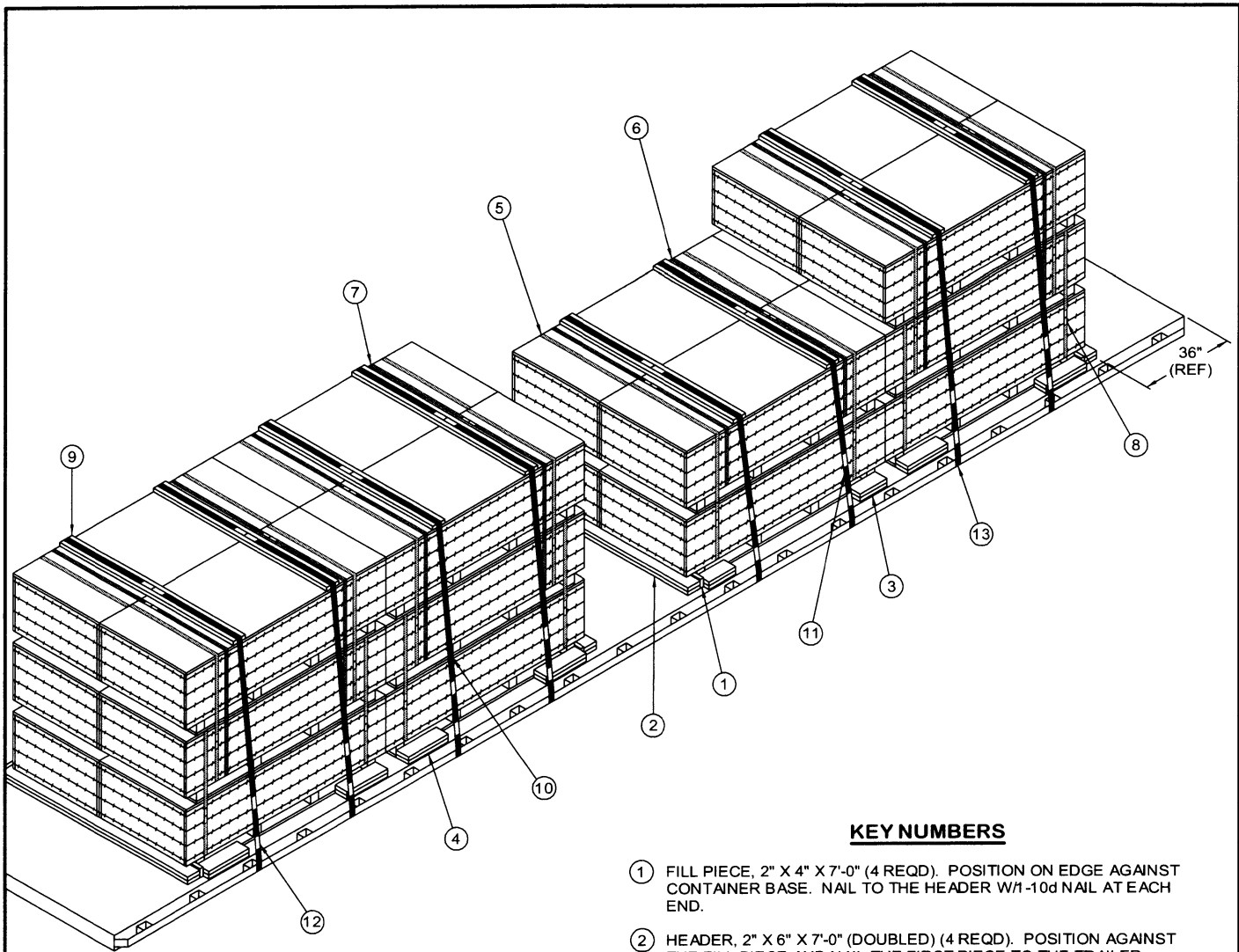

ISOMETRIC VIEW

(KEY NUMBERS CONTINUED)

- ⑩ HOLD-DOWN STRAP, 2" X .050" OR .044" X 29'-6" LONG STEEL STRAPPING (6 REQD). INSTALL EACH STRAP FROM TWO 14'-9" LONG PIECES. STAPLE A STRAP TO PIECE MARKED ⑨ W/1-STAPLE AT EACH END. SEE THE STRAP JOINT "A" AND "B" DETAILS ON PAGE 15.
- ⑪ HOLD-DOWN STRAP, 2" X .050" OR .044" X 25'-0" LONG STEEL STRAPPING (2 REQD). INSTALL EACH STRAP FROM TWO 12'-6" LONG PIECES. SECURE THE SAME AS PIECE MARKED ⑩.
- ⑫ SEAL FOR 2" STEEL STRAPPING (48 REQD, 6 PER STRAP). DOUBLE CRIMP EACH SEAL EXCEPT THOSE USED TO SECURE THE PADS, PIECES MARKED ⑬.
- ⑬ PAD, 2" X .050" OR .044" X 18" LONG STEEL STRAPPING (16 REQD). POSITION UNDER STAKE POCKET OR RUB RAIL AND SEAL TO THE HOLD-DOWN STRAP. ALT: STAKE POCKET PROTECTOR (32 REQD). USE TWO UNDER EACH STAKE POCKET OR RUB RAIL WITH A HOLD-DOWN STRAP.

KEY NUMBERS

- ① FILL PIECE, 2" X 4" X 7'-0" (4 REQD). POSITION ON EDGE AGAINST CONTAINER BASE. NAIL TO THE HEADER W/1-10d NAIL AT EACH END.
- ② HEADER, 2" X 6" X 7'-0" (DOUBLED) (4 REQD). POSITION AGAINST THE FILL PIECE AND NAIL THE FIRST PIECE TO THE TRAILER FLOOR W/5-10d NAILS. NAIL THE SECOND PIECE TO THE FIRST W/5-20d NAILS. SEE GENERAL NOTE "J" ON PAGE 2.
- ③ SIDE BLOCKING, 2" X 6" X 12" (DOUBLED) (4 REQD). POSITION AT EACH END OF THE CONTAINER BASE AND NAIL THE FIRST PIECE TO THE TRAILER FLOOR W/4-10d NAILS. NAIL THE SECOND PIECE TO THE FIRST IN A LIKE MANNER.
- ④ SIDE BLOCKING, 2" X 6" X 18" (DOUBLED) (12 REQD). POSITION AT EACH END OF THE CONTAINER BASE AND NAIL THE FIRST PIECE TO THE TRAILER FLOOR W/5-10d NAILS. NAIL THE SECOND PIECE TO THE FIRST IN A LIKE MANNER.
- ⑤ UNITIZING STRAP, 1-1/4" X .035" OR .031" X 16'-0" LONG STEEL STRAPPING (28 REQD). INSTALL SO AS TO ENCIRCLE A STACK OF TWO CONTAINERS. ALSO INSTALL SO AS TO ENCIRCLE THE BOTTOM TWO CONTAINERS AND THE TOP TWO CONTAINERS IN THE 3-HIGH STACKS. SEE SPECIAL NOTE 3 ON PAGE 5.
- ⑥ BUNDLING STRAP, 1-1/4" X .035" OR .031" X 18'-6" LONG STEEL STRAPPING (2 REQD). INSTALL SO AS TO ENCIRCLE THE Laterally ADJACENT UNITS IN THE TOP LAYER AS SHOWN.
- ⑦ BUNDLING STRAP, 1-1/4" X .035" OR .031" X 23'-0" LONG STEEL STRAPPING (6 REQD). INSTALL SO AS TO ENCIRCLE THE Laterally ADJACENT UNITS IN THE TOP LAYERS AS SHOWN.
- ⑧ SEAL FOR 1-1/4" STRAPPING (72 REQD, 2 PER STRAP). DOUBLE CRIMP EACH SEAL. SEE GENERAL NOTE "K" ON PAGE 2.
- ⑨ STRAPPING BOARD, 2" X 6" X 6'-6" (8 REQD).

SPECIAL NOTES:

1. A 22-CONTAINER LOAD IS SHOWN ON A 40'-0" LONG BY 8'-0" WIDE FLATBED TRAILER. TRAILERS OF OTHER LENGTHS CAN BE USED.
2. IF DESIRED, AND IF THE CAPACITY OF THE FORKLIFT TRUCK PERMITS, STACKS OF TWO CONTAINERS MAY BE UNITIZED WITH TWO STEEL STRAPS PRIOR TO PLACEMENT ON THE TRAILER.
3. THE PROCEDURES SHOWN IN THE LOAD ON PAGE 4 ARE APPLICABLE TO THE WIREBOUND WRAP-AROUND CONTAINER. NOTE THAT ALL STEEL STRAPPING, PIECES MARKED (5), (6), (7), (10), AND (11) WILL BE SLIGHTLY SHORTER THAN SHOWN FOR THE PLYWOOD TWIN PACK CONTAINER.

BILL OF MATERIAL

LUMBER	LINEAR FEET	BOARD FEET
2" X 4"	28	19
2" X 6"	152	152
NAILS	NO. REQD	POUNDS
10d (3")	180	3
20d (4 ")	20	3/4
STEEL STRAPPING, 1-1/4" ----- 623' REQD ----- 89 LBS		
STEEL STRAPPING, 2" ----- 251' REQD ----- 84 LBS		
SEAL FOR 1-1/4" STRAPPING ----- 72 REQD ----- 3-1/4 LBS		
SEAL FOR 2" STRAPPING ----- 48 REQD ----- 10 LBS		
STAPLE FOR 2" STRAPPING ----- 16 REQD ----- NIL		

LOAD AS SHOWN

<u>ITEM</u>	<u>QUANTITY</u>	<u>WEIGHT (APPROX)</u>
CONTAINER -----	22 -----	40,810 LBS
DUNNAGE -----		532 LBS
<hr/>		
TOTAL WEIGHT -----		41,342 LBS (APPROX)

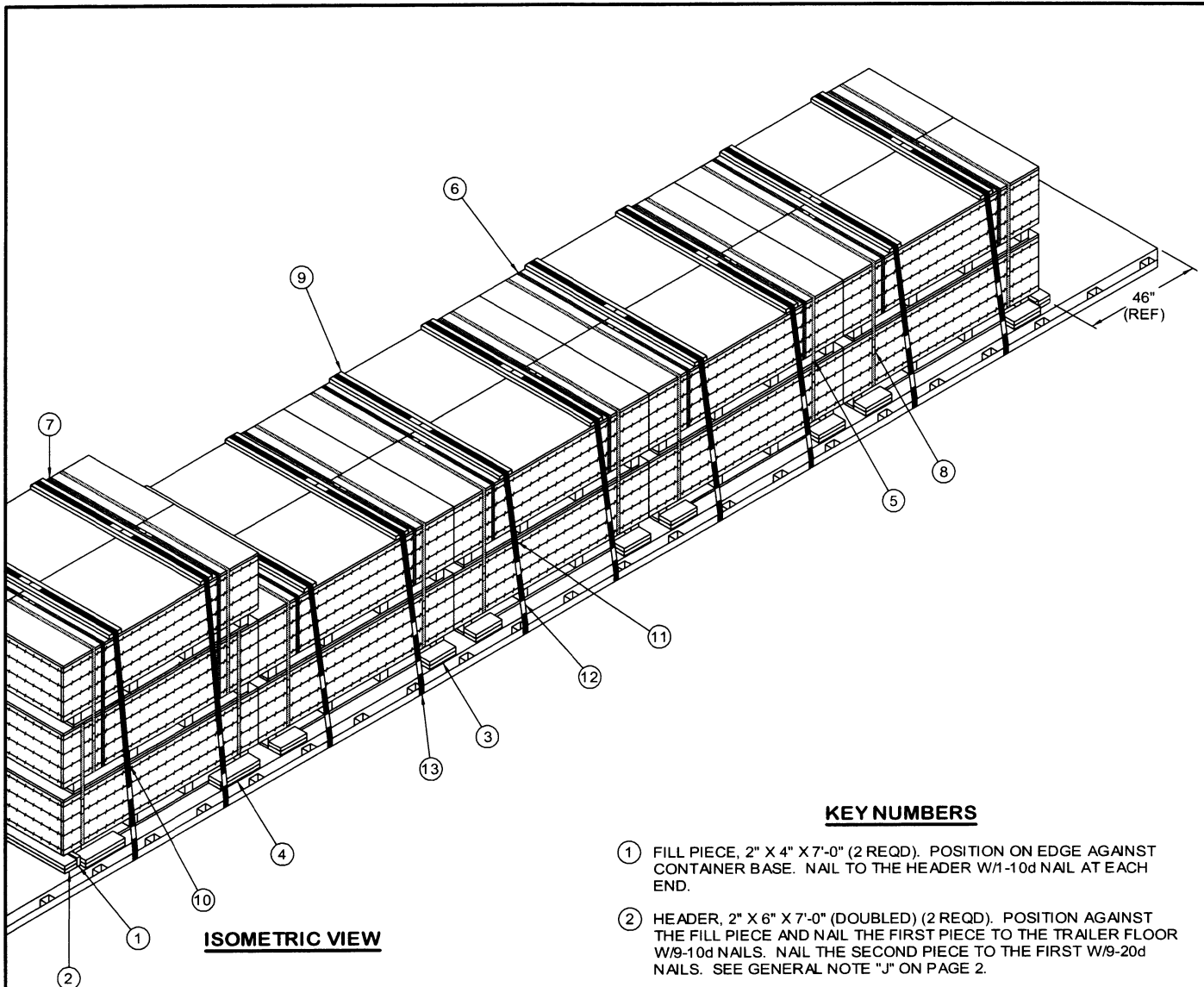

ISOMETRIC VIEW

KEY NUMBERS

- ① FILL PIECE, 2" X 4" X 7'-0" (2 REQD). POSITION ON EDGE AGAINST CONTAINER BASE. NAIL TO THE HEADER W/1-10d NAIL AT EACH END.
- ② HEADER, 2" X 6" X 7'-0" (DOUBLED) (2 REQD). POSITION AGAINST THE FILL PIECE AND NAIL THE FIRST PIECE TO THE TRAILER FLOOR W/9-10d NAILS. NAIL THE SECOND PIECE TO THE FIRST W/9-20d NAILS. SEE GENERAL NOTE "J" ON PAGE 2.
- ③ SIDE BLOCKING, 2" X 6" X 12" (DOUBLED) (16 REQD). POSITION AT EACH END OF THE CONTAINER BASE AND NAIL THE FIRST PIECE TO THE TRAILER FLOOR W/4-10d NAILS. NAIL THE SECOND PIECE TO THE FIRST IN A LIKE MANNER.
- ④ SIDE BLOCKING, 2" X 6" X 18" (DOUBLED) (4 REQD). POSITION AT EACH END OF THE CONTAINER BASE AND NAIL THE FIRST PIECE TO THE TRAILER FLOOR W/5-10d NAILS. NAIL THE SECOND PIECE TO THE FIRST IN A LIKE MANNER.
- ⑤ UNITIZING STRAP, 1-1/4" X .035" OR .031" X 16'-0" LONG STEEL STRAPPING (24 REQD). INSTALL SO AS TO ENCIRCLE A STACK OF TWO CONTAINERS. ALSO INSTALL SO AS TO ENCIRCLE THE BOTTOM TWO CONTAINERS AND THE TOP TWO CONTAINERS IN THE 3-HIGH STACKS. SEE SPECIAL NOTE 3 ON PAGE 7.
- ⑥ BUNDLING STRAP, 1-1/4" X .035" OR .031" X 18'-6" LONG STEEL STRAPPING (8 REQD). INSTALL SO AS TO ENCIRCLE THE LATERALLY ADJACENT UNITS IN THE TOP LAYER AS SHOWN.
- ⑦ BUNDLING STRAP, 1-1/4" X .031" OR .035" X 23'-0" LONG STEEL STRAPPING (2 REQD). INSTALL SO AS TO ENCIRCLE THE LATERALLY ADJACENT UNITS IN THE TOP LAYERS AS SHOWN.
- ⑧ SEAL FOR 1-1/4" STRAPPING (68 REQD, 2 PER STRAP). DOUBLE CRIMP EACH SEAL. SEE GENERAL NOTE "K" ON PAGE 2.
- ⑨ STRAPPING BOARD, 2" X 6" X 6'-6" (10 REQD).

(KEY NUMBERS CONTINUED)

- ⑩ HOLD-DOWN STRAP, 2" X .050" OR .044" X 29'-6" LONG STEEL STRAPPING (2 REQD). INSTALL EACH STRAP FROM TWO 14'-9" LONG PIECES. STAPLE A STRAP TO PIECE MARKED ⑨ W/1-STAPLE AT EACH END. SEE THE STRAP JOINT "A" AND "B" DETAILS ON PAGE 15.
- ⑪ HOLD-DOWN STRAP, 2" X .050" OR .044" X 25'-0" LONG STEEL STRAPPING (8 REQD). INSTALL EACH STRAP FROM TWO 12'-6" LONG PIECES. SECURE THE SAME AS PIECE MARKED ⑩.
- ⑫ SEAL FOR 2" STEEL STRAPPING (60 REQD, 6 PER STRAP). DOUBLE CRIMP EACH SEAL EXCEPT THOSE USED TO SECURE THE PADS, PIECES MARKED ⑬.
- ⑬ PAD, 2" X .050" OR .044" X 18" LONG STEEL STRAPPING (20 REQD). POSITION UNDER STAKE POCKET OR RUB RAIL AND SEAL TO THE HOLD-DOWN STRAP. ALT: STAKE POCKET PROTECTOR (40 REQD). USE TWO UNDER EACH STAKE POCKET OR RUB RAIL WITH A HOLD-DOWN STRAP.

SPECIAL NOTES:

1. A 22-CONTAINER LOAD IS SHOWN ON A 45'-0" LONG BY 8'-0" WIDE FLATBED TRAILER. TRAILERS OF OTHER LENGTHS CAN BE USED.
2. IF DESIRED, AND IF THE CAPACITY OF THE FORKLIFT TRUCK PERMITS, STACKS OF TWO CONTAINERS MAY BE UNITIZED WITH TWO STEEL STRAPS PRIOR TO PLACEMENT ON THE TRAILER.
3. THE PROCEDURES SHOWN IN THE LOAD ON PAGE 6 ARE APPLICABLE TO THE WIREBOUND WRAP-AROUND CONTAINER. NOTE THAT ALL STEEL STRAPPING, PIECES MARKED ⑤, ⑥, ⑦, ⑩, AND ⑪ WILL BE SLIGHTLY SHORTER THAN SHOWN FOR THE PLYWOOD TWIN PACK CONTAINER.

BILL OF MATERIAL

LUMBER	LINEAR FEET	BOARD FEET
2" X 4"	14	10
2" X 6"	137	137
NAILS	NO. REQD	POUNDS
10d (3")	190	3
20d (4")	18	3/4
STEEL STRAPPING, 1-1/4" ----- 578' REQD ----- 82-3/4 LBS		
STEEL STRAPPING, 2" ----- 259' REQD ----- 86-1/2 LBS		
SEAL FOR 1-1/4" STRAPPING ----- 68 REQD ----- 3-1/4 LBS		
SEAL FOR 2" STRAPPING ----- 60 REQD ----- 12 LBS		
STAPLE FOR 2" STRAPPING ----- 20 REQD ----- NIL		

LOAD AS SHOWN

<u>ITEM</u>	<u>QUANTITY</u>	<u>WEIGHT (APPROX)</u>
CONTAINER -----	22 -----	40,810 LBS
DUNNAGE -----		483 LBS
TOTAL WEIGHT -----		41,293 LBS (APPROX)

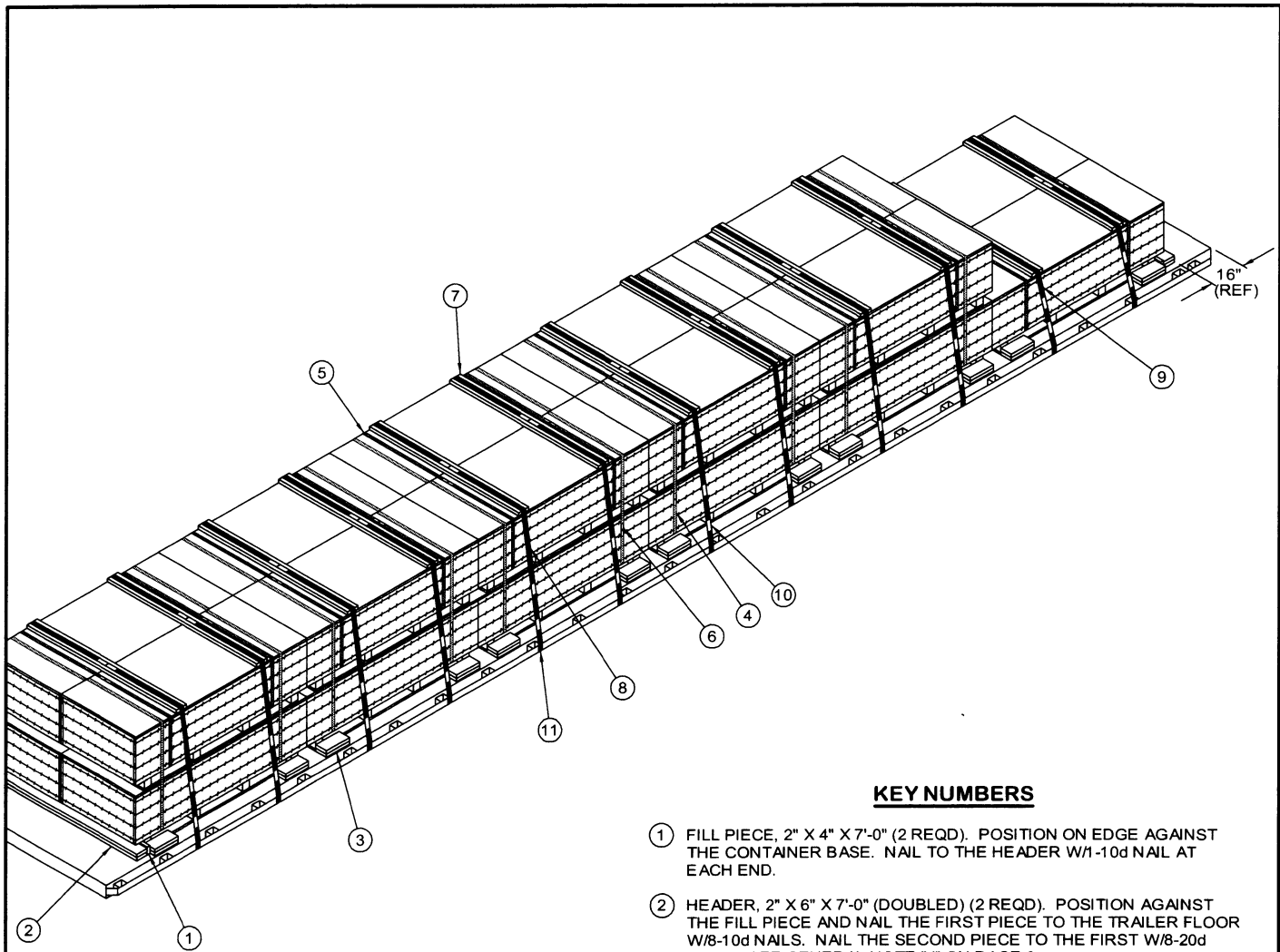

16"
(REF)

ISOMETRIC VIEW

KEY NUMBERS

- ① FILL PIECE, 2" X 4" X 7'-0" (2 REQD). POSITION ON EDGE AGAINST THE CONTAINER BASE. NAIL TO THE HEADER W/1-10d NAIL AT EACH END.
- ② HEADER, 2" X 6" X 7'-0" (DOUBLED) (2 REQD). POSITION AGAINST THE FILL PIECE AND NAIL THE FIRST PIECE TO THE TRAILER FLOOR W/8-10d NAILS. NAIL THE SECOND PIECE TO THE FIRST W/8-20d NAILS. SEE GENERAL NOTE "J" ON PAGE 2.
- ③ SIDE BLOCKING, 2" X 6" X 12" (DOUBLED) (24 REQD). POSITION AT EACH END OF THE CONTAINER BASE AND NAIL THE FIRST PIECE TO THE TRAILER FLOOR W/4-10d NAILS. NAIL THE SECOND PIECE TO THE FIRST IN A LIKE MANNER.
- ④ UNITIZING STRAP, 1-1/4" X .035" OR .031" X 16'-0" LONG STEEL STRAPPING (16 REQD). INSTALL SO AS TO ENIRCLE A STACK OF TWO CONTAINERS. SEE SPECIAL NOTE 3 ON PAGE 9.
- ⑤ BUNDLING STRAP, 1-1/4" X .035" OR .031" X 18'-6" LONG STEEL STRAPPING (8 REQD). INSTALL SO AS TO ENIRCLE THE LATERALLY ADJACENT UNITS IN THE TOP LAYER AS SHOWN.
- ⑥ SEAL FOR 1-1/4" STEEL STRAPPING (48 REQD, 2 PER STRAP). DOUBLE CRIMP EACH SEAL. SEE GENERAL NOTE "K" ON PAGE 2.
- ⑦ STRAPPING BOARD, 2" X 6" X 6'-6" (12 REQD).
- ⑧ HOLD-DOWN STRAP, 2" X .050" OR .044" X 25'-0" LONG STEEL STRAPPING (8 REQD). INSTALL EACH STRAP FROM TWO 12'-6" LONG PIECES. STAPLE A STRAP TO PIECE MARKED ⑦ W/1-STAPLE AT EACH END. SEE THE "END-OVER-END STRAP JOINT DETAILS" ON PAGE 15.
- ⑨ HOLD-DOWN STRAP, 2" X .050" OR .044" X 21'-0" LONG STEEL STRAPPING (4 REQD). INSTALL EACH STRAP FROM TWO 10'-6" LONG PIECES. SECURE THE SAME AS PIECE MARKED ⑧.
- ⑩ SEAL FOR 2" STEEL STRAPPING (72 REQD, 6 PER STRAP). DOUBLE CRIMP EACH SEAL EXCEPT THOSE USED TO SECURE THE PADS, PIECES MARKED ⑪.
- ⑪ PAD, 2" X .050" OR .044" X 18" LONG STEEL STRAPPING (24 REQD). POSITION UNDER STAKE POCKET OR RUB RAIL AND SEAL TO THE HOLD-DOWN STRAP. ALT: STAKE POCKET PROTECTOR (48 REQD). USE TWO UNDER EACH STAKE POCKET OR RUB RAIL WITH A HOLD-DOWN STRAP.

SPECIAL NOTES:

1. A 20-CONTAINER LOAD IS SHOWN ON A 48'-0" LONG BY 8'-0" WIDE FLATBED TRAILER. TRAILERS OF OTHER LENGTHS CAN BE USED.
2. IF DESIRED, AND IF THE CAPACITY OF THE FORKLIFT TRUCK PERMITS, STACKS OF TWO CONTAINERS MAY BE UNITIZED WITH TWO STEEL STRAPS PRIOR TO PLACEMENT ON THE TRAILER.
3. THE PROCEDURES SHOWN IN THE LOAD ON PAGE 8 ARE APPLICABLE TO THE WIREBOUND WRAP-AROUND CONTAINER. NOTE THAT ALL STEEL STRAPPING, PIECES MARKED ④, ⑤, ⑧, AND ⑨ WILL BE SLIGHTLY SHORTER THAN SHOWN FOR THE PLYWOOD TWIN PACK CONTAINER.

BILL OF MATERIAL

LUMBER	LINEAR FEET	BOARD FEET
2" X 4"	14	10
2" X 6"	154	154
NAILS	NO. REQD	POUNDS
10d (3")	214	3-1/2
20d (4 ")	18	3/4
STEEL STRAPPING, 1-1/4" ----- 542' REQD ----- 77-1/2 LBS		
STEEL STRAPPING, 2" ----- 292' REQD ----- 97-1/2 LBS		
SEAL FOR 1-1/4" STRAPPING ----- 64 REQD ----- 3 LBS		
SEAL FOR 2" STRAPPING ----- 72 REQD ----- 14-1/2 LBS		
STAPLE FOR 2" STRAPPING ----- 24 REQD ----- NIL		

LOAD AS SHOWN

<u>ITEM</u>	<u>QUANTITY</u>	<u>WEIGHT (APPROX)</u>
CONTAINER -----	22 -----	40,810 LBS
DUNNAGE -----		525 LBS
<hr/>		
TOTAL WEIGHT -----		41,335 LBS (APPROX)

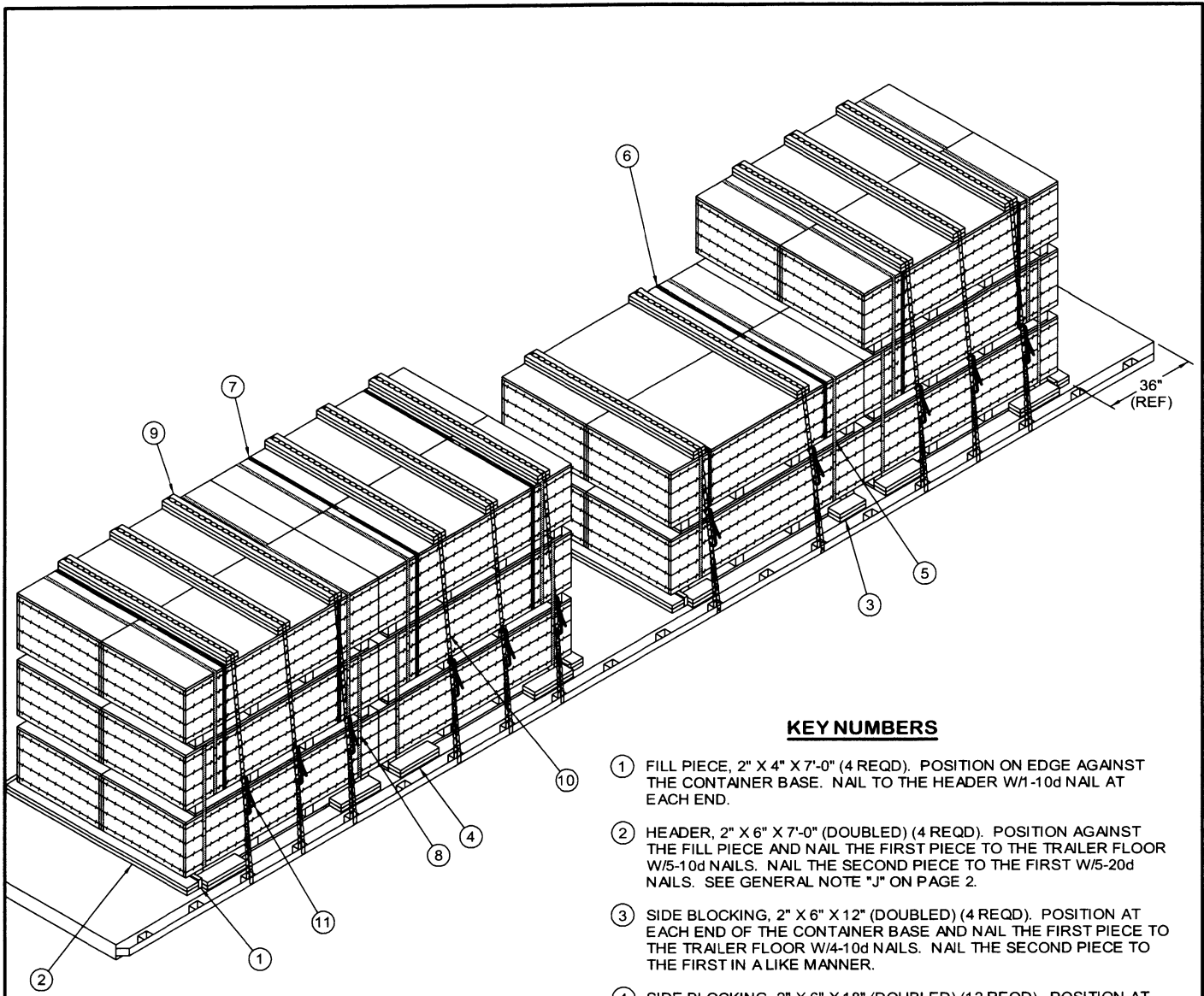

ISOMETRIC VIEW

KEY NUMBERS

- ① FILL PIECE, 2" X 4" X 7'-0" (4 REQD). POSITION ON EDGE AGAINST THE CONTAINER BASE. NAIL TO THE HEADER W/1-10d NAIL AT EACH END.
- ② HEADER, 2" X 6" X 7'-0" (DOUBLED) (4 REQD). POSITION AGAINST THE FILL PIECE AND NAIL THE FIRST PIECE TO THE TRAILER FLOOR W/5-10d NAILS. NAIL THE SECOND PIECE TO THE FIRST W/5-20d NAILS. SEE GENERAL NOTE "J" ON PAGE 2.
- ③ SIDE BLOCKING, 2" X 6" X 12" (DOUBLED) (4 REQD). POSITION AT EACH END OF THE CONTAINER BASE AND NAIL THE FIRST PIECE TO THE TRAILER FLOOR W/4-10d NAILS. NAIL THE SECOND PIECE TO THE FIRST IN A LIKE MANNER.
- ④ SIDE BLOCKING, 2" X 6" X 18" (DOUBLED) (12 REQD). POSITION AT EACH END OF THE CONTAINER BASE AND NAIL THE FIRST PIECE TO THE TRAILER FLOOR W/5-10d NAILS. NAIL THE SECOND PIECE TO THE FIRST IN A LIKE MANNER.
- ⑤ UNITIZING STRAP, 1-1/4" X .031" OR .035" X 16'-0" LONG STEEL STRAPPING (28 REQD). INSTALL SO AS TO ENCIRCLE A STACK OF TWO CONTAINERS. ALSO INSTALL SO AS TO ENCIRCLE THE BOTTOM TWO CONTAINERS AND THE TOP TWO CONTAINERS IN THE 3-HIGH STACKS.
- ⑥ BUNDLING STRAP, 1-1/4" X .031" OR .035" X 18'-6" LONG STEEL STRAPPING (2 REQD). INSTALL SO AS TO ENCIRCLE THE LATERALLY ADJACENT UNITS IN THE TOP LAYER AS SHOWN.
- ⑦ BUNDLING STRAP, 1-1/4" X .031" OR .035" X 23'-0" LONG STEEL STRAPPING (6 REQD). INSTALL SO AS TO ENCIRCLE THE LATERALLY ADJACENT UNITS IN THE TOP LAYERS AS SHOWN.
- ⑧ SEAL FOR 1-1/4" STRAPPING (72 REQD, 2 PER STRAP). DOUBLE CRIMP EACH SEAL. SEE GENERAL NOTE "K" ON PAGE 2.
- ⑨ CHAIN BOARD, 2" X 6" X 6'-6" (DOUBLED) (11 REQD). LAMINATE W/5-10d NAILS.
- ⑩ CHAIN, BINDING, 5/16" GRADE BY A LENGTH TO SUIT (11 REQD). POSITION AS SHOWN ABOVE, FASTENING THE CHAIN TO THE TRAILER STAKE POCKETS. SEE "SPECIAL PROVISIONS FOR CHAIN TIEDOWNS" ON PAGE 11.
- ⑪ LOAD BINDER, 5/16", OVERCENTER TYPE (11 REQD, 1 PER CHAIN). WIRE TIE HANDLE TO PREVENT OPENING DURING TRANSPORT. FASTEN THE TENSIONED CHAIN, PIECE MARKED ⑩, TO THE CHAIN BOARD, PIECE MARKED ⑨, W/1-20d NAIL AT EACH END BENDING OVER TO FORM A LOOP AROUND THE CHAIN LINK.

SPECIAL NOTES:

1. A 22-CONTAINER LOAD IS SHOWN ON A 40'-0" LONG BY 8'-0" WIDE FLATBED TRAILER. TRAILERS OF OTHER LENGTHS CAN BE USED. SEE SPECIAL NOTE 3 BELOW.
2. THE PROCEDURES DEPICTED ON PAGES 10 AND A11 CAN BE USED FOR ANY OF THE LOADS SHOWN HEREIN. NOTE: THE CHAINS MUST BE ATTACHED TO THE TRAILER STAKE POCKETS AND VERTICALLY IN LINE WITH THE CHAIN BOARDS. THE CHAIN BOARDS CAN BE SHIFTED LEFT OR RIGHT TO PROVIDE FOR VERTICAL ALIGNMENT. IT MAY BE NECESSARY IN SOME LOADS TO SHIFT THE CONTAINERS WITH DUNNAGE TO COMPLY WITH THIS LOADING REQUIREMENT. SEE GENERAL NOTE "L" ON PAGE 2.
3. PRIOR TO PLACING CONTAINERS ON A 40'-0" LONG TRAILER FOR THE 22-CONTAINER LOAD AS SHOWN, TWO FILL PIECES AND TWO HEADERS, PIECES MARKED ① AND ②, MUST FIRST BE INSTALLED ON THE CENTER LINE OF THE LENGTH OF THE TRAILER BED SO THAT THE CONTAINERS WILL BE POSITIONED TO COMPLY WITH THE REQUIREMENTS OF NOTE 2 ABOVE AS PERTAINS TO VERTICAL ALIGNMENT OF CHAINS, CHAIN BOARDS, AND TRAILER STAKE POCKETS.
4. IF DESIRED, AND IF THE CAPACITY OF THE FORKLIFT TRUCK PERMITS, TWO CONTAINERS MAY BE STACKED AND UNITIZED WITH TWO STEEL STRAPS PRIOR TO LOADING.

SPECIAL PROVISIONS FOR CHAIN TIEDOWN

LADING MAY BE SECURED TO THE FLATBED TRAILER BY CARRIER-OWNED CHAINS AND LOAD BINDERS IN LIEU OF SPECIFIED STRAPPING, PROVIDED THE FOLLOWING CONDITIONS ARE MET AND THE PROCEDURES CONTAINED ON PAGES 10 AND 11 ARE FOLLOWED.

1. ONLY CHAINS AND LOAD BINDERS OF GOOD QUALITY WILL BE USED. ALL CHAINS AND LOAD BINDERS SHALL CONFORM TO THE NATIONAL ASSOCIATION OF CHAIN MANUFACTURER'S WELDED CHAIN SPECIFICATION ADOPTED NOVEMBER 1975.
2. ALL CHAINS SHALL BE MARKED AS PRESCRIBED BY THE NATIONAL ASSOCIATION OF CHAIN MANUFACTURER'S WELDED CHAIN SPECIFICATION ADOPTED NOVEMBER 1975. AT LEAST ONE LINK IN EVERY 36 LINKS SHALL CARRY THE MANUFACTURER'S PERMANENT AND DISTINCTIVE MARK IDENTIFYING THE GRADE OF CHAIN. CHAINS NOT MARKED IN THIS MANNER SHALL NOT BE USED. IN ADDITION TO THE GRADE MARKING, THE CHAIN MAY ALSO CARRY LETTER MARKINGS OR SYMBOLS IDENTIFYING THE CHAIN MANUFACTURER. THE PRESENCE OF THE MANUFACTURER'S IDENTIFICATION MARKING IS NOT MANDATORY.
3. BEFORE AND DURING INSTALLATION, THE CHAINS AND LOAD BINDERS SHALL BE INSPECTED FOR BENT HOOKS, STRETCH, GOUGES, BENT LINKS, WEAR, OR ANY OTHER NOTICEABLE DEFECTS. ANY DEFICIENCY SHALL BE CAUSE FOR REJECTION OF A CHAIN OR LOAD BINDER. CHAINS MUST NOT BE TWISTED DURING INSTALLATION. CAUTION: EXTREME CARE MUST BE EXERCISED WHEN TENSIONING CHAINS TO PREVENT DAMAGE OR PERMANENT DEFORMATION TO THE LADING.
4. CHAIN SIZES AND GRADES APPROVED FOR USE WITH FLATBED TRAILER LOADS ARE AS FOLLOWS:
 - A. 3/8", GRADE 43 HIGH TEST CHAIN
 - B. 5/16", GRADE 70 BINDING CHAIN
 - C. 3/8", GRADE 70 BINDING CHAIN
 - D. 5/16", GRADE 80 ALLOY STEEL CHAIN
 - E. 3/8", GRADE 80 ALLOY STEEL CHAIN
5. THE GRABHOOKS ON THE ENDS OF THE CHAIN MAY BE OF THE FOLLOWING TYPES WITH GRADE MARKINGS AS INDICATED.
 - A. CLEVIS GRABHOOKS, 3/8" SIZE, DO NOT REQUIRE GRADE MARKING. ALLOY GRABHOOKS, 5/16" SIZE, SHALL CARRY THE MANUFACTURER'S GRADE MARK OF 7, 70, OR 700. THE HOOKS SHALL BE USED ON THE APPROPRIATE SIZE CHAIN.
 - B. CLOSED EYE GRABHOOKS, 3/8" AND 5/16" SIZE, MAY BE USED ON THE APPROPRIATE SIZE CHAIN IF THEY ARE A PART OF A CHAIN ASSEMBLY WHICH WAS PROVIDED BY A CHAIN MANUFACTURER, AND THE CHAIN ASSEMBLY CARRIES THE CORRECT GRADE IDENTIFICATION MARKING AS PREVIOUSLY STATED. CLOSED EYE GRABHOOKS THAT FORM A PART OF THE CHAIN ASSEMBLY ARE EXEMPT FROM GRADE MARKINGS.
6. CONNECTING LINKS USED FOR CHAIN REPAIR MUST BE CORRECTLY MARKED AND BE EQUAL TO OR GREATER IN STRENGTH THAN THE CHAIN THEY ARE REPAIRING. CHAINS WITH UNMARKED CONNECTING LINKS SHALL NOT BE USED.
7. CHAIN AND FITTING OF A HIGHER GRADE MAY BE SUBSTITUTED FOR THE GRADES SPECIFIED IN NOTE 4 ABOVE.
8. LOAD BINDERS SHALL BE 5/16" TO 3/8" SIZE AND HAVE A MINIMUM BREAKING STRENGTH OF 16,200 POUNDS (WORKING LOAD LIMIT OF 5,400 POUNDS). OVERCENTER TYPE LOAD BINDERS SHALL BE SAFETY WIRED TO PREVENT ACCIDENTAL OPENING DURING TRANSPORT. LOAD BINDER SIZE SHALL BE COMPATIBLE WITH THE SIZE OF THE CHAIN BEING USED.

BILL OF MATERIAL		
LUMBER	LINEAR FEET	BOARD FEET
2" X 4"	28	19
2" X 6"	243	243
NAILS	NO. REQD	POUNDS
10d (3")	241	3-3/4
20d (4 ")	42	1-1/2
STEEL STRAPPING, 1-1/4" ----- 623' REQD ----- 89 LBS		
SEAL FOR 1-1/4" STRAPPING ----- 72 REQD ----- 3-1/4 LBS		
CHAIN, BINDING, 5/16" ----- 270' REQD ----- 324 LBS		
LOAD BINDER ----- 11 REQD ----- 66 LBS		

LOAD AS SHOWN

<u>ITEM</u>	<u>QUANTITY</u>	<u>WEIGHT (APPROX)</u>
CONTAINER -----	22 -----	40,810 LBS
DUNNAGE -----	-----	1,012 LBS
TOTAL WEIGHT -----		41,822 LBS (APPROX)

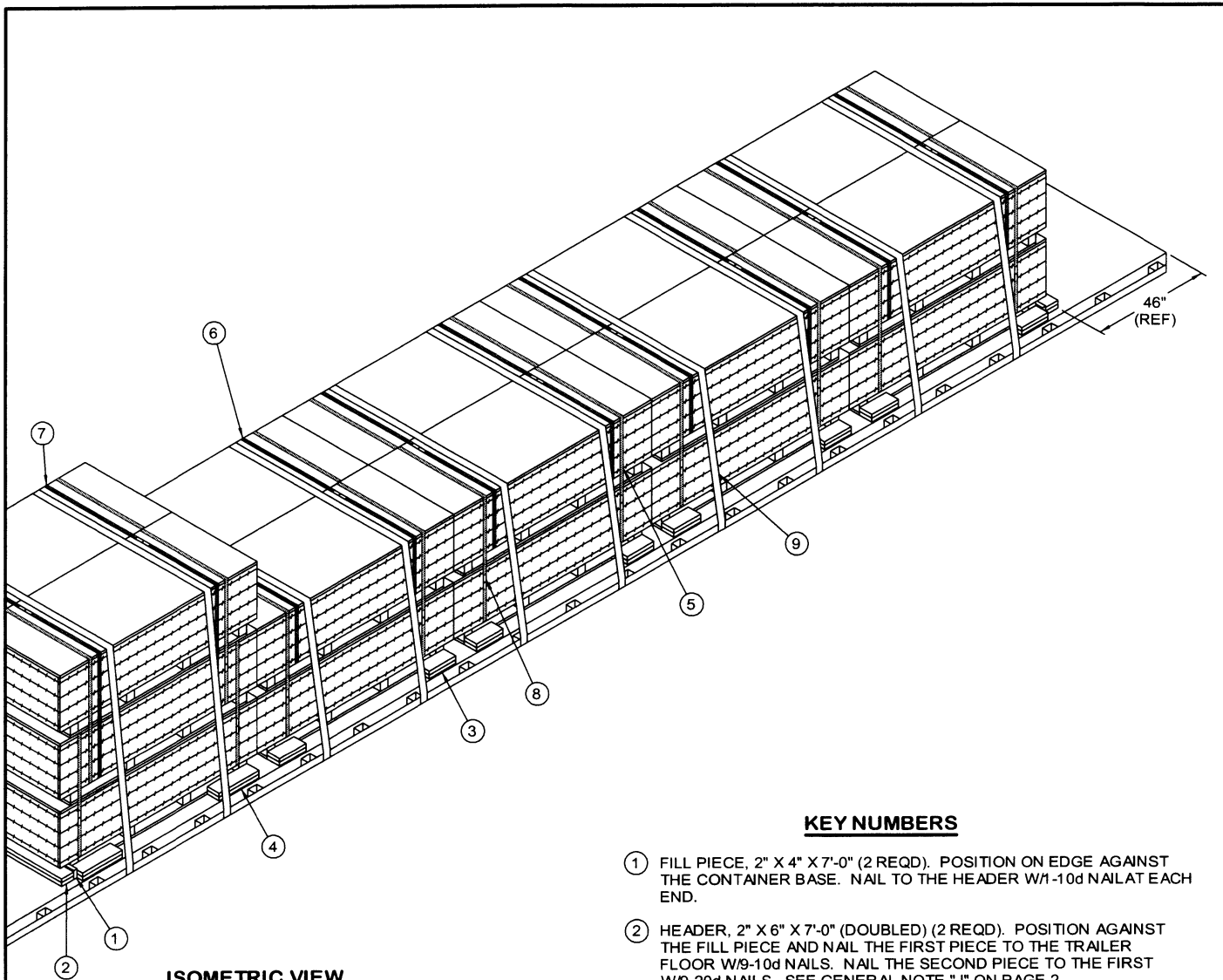

ISOMETRIC VIEW

KEY NUMBERS

- ① FILL PIECE, 2" X 4" X 7'-0" (2 REQD). POSITION ON EDGE AGAINST THE CONTAINER BASE. NAIL TO THE HEADER W/1-10d NAIL AT EACH END.
- ② HEADER, 2" X 6" X 7'-0" (DOUBLED) (2 REQD). POSITION AGAINST THE FILL PIECE AND NAIL THE FIRST PIECE TO THE TRAILER FLOOR W/9-10d NAILS. NAIL THE SECOND PIECE TO THE FIRST W/9-20d NAILS. SEE GENERAL NOTE "J" ON PAGE 2.
- ③ SIDE BLOCKING, 2" X 6" X 12" (DOUBLED) (16 REQD). POSITION AT EACH END OF THE CONTAINER BASE AND NAIL THE FIRST PIECE TO THE TRAILER FLOOR W/4-10d NAILS. NAIL THE SECOND PIECE TO THE FIRST IN A LIKE MANNER.
- ④ SIDE BLOCKING, 2" X 6" X 18" (DOUBLED) (4 REQD). POSITION AT EACH END OF THE CONTAINER BASE AND NAIL THE FIRST PIECE TO THE TRAILER FLOOR W/5-10d NAILS. NAIL THE SECOND PIECE TO THE FIRST IN A LIKE MANNER.
- ⑤ UNITIZING STRAP, 1-1/4" X .031" OR .035" X 16'-0" LONG STEEL STRAPPING (24 REQD). INSTALL SO AS TO ENCIRCLE A STACK OF TWO CONTAINERS. ALSO INSTALL SO AS TO ENCIRCLE THE BOTTOM TWO CONTAINERS AND THE TOP TWO CONTAINERS IN THE 3-HIGH STACKS. SEE SPECIAL NOTE 3 ON PAGE 7.
- ⑥ BUNDLING STRAP, 1-1/4" X .031" OR .035" X 18'-6" LONG STEEL STRAPPING (8 REQD). INSTALL SO AS TO ENCIRCLE THE LATERALLY ADJACENT UNITS IN THE TOP LAYER AS SHOWN.
- ⑦ BUNDLING STRAP, 1-1/4" X .031" OR .035" X 23'-0" LONG STEEL STRAPPING (2 REQD). INSTALL SO AS TO ENCIRCLE THE LATERALLY ADJACENT UNITS IN THE TOP LAYERS AS SHOWN.
- ⑧ SEAL FOR 1-1/4" STRAPPING (68 REQD, 2 PER STRAP). DOUBLE CRIMP EACH SEAL. SEE GENERAL NOTE "K" ON PAGE 2.
- ⑨ WEB STRAP ASSEMBLY (10 REQD). POSITION TO EXTEND FROM A WINCH ON ONE SIDE OF THE TRAILER, OVER THE CONTAINERS, TO AN ATTACHMENT POINT ON THE OPPOSITE SIDE. SEE THE "SPECIAL PROVISIONS FOR WEB STRAP TIEDOWN" ON PAGE 13.

SPECIAL PROVISIONS FOR WEB STRAP TIEDOWN

LADING MAY BE SECURED TO A FLATBED TRAILER BY WEB STRAP ASSEMBLIES IN LIEU OF STEEL STRAPPING OR CHAINS AND LOAD BINDERS, PROVIDED THE FOLLOWING CONDITIONS ARE MET.

1. ONLY WEB STRAPS OF GOOD QUALITY WILL BE USED. ALL WEB STRAPS AND ASSOCIATED HARDWARE SHALL CONFORM TO THE WEB SLING & TIEDOWN ASSOCIATION RECOMMENDED STANDARD SPECIFICATION FOR SYNTHETIC WEB TIEDOWNS, FIRST PUBLISHED IN 1991.
2. ALL WEB STRAP TIEDOWN ASSEMBLIES SHALL BE PERMANENTLY LABELED WITHIN 18" OF ONE END TO SHOW:
 - A. NAME OR TRADEMARK OF MANUFACTURER
 - B. WORKING LOAD LIMIT (WLL)
 - C. DATE OF MANUFACTURE (MONTH AND YEAR)
3. WEB STRAP ASSEMBLY MINIMUM BREAKING STRENGTH WILL BE AT LEAST THREE TIMES THE WLL MARKED ON THE STRAP.
4. THE TOTAL MINIMUM BREAKING STRENGTH (MBS) OF THE STRAPS USED TO RESTRAIN AMMUNITION ITEMS WILL BE AT LEAST 1-1/2 TIMES THE TOTAL WEIGHT OF THE ITEMS, WITH A MINIMUM OF TWO STRAPS POSITIONED OVER EACH LOAD UNIT ON A TRAILER. WRITTEN PROOF OF THE MBS OF THE STRAPS SHALL BE PROVIDED BY THE CARRIER TO THE SHIPPING ACTIVITY IF REQUESTED.
5. CARRIERS MUST COMPLY WITH ALL FEDERAL, STATE, AND LOCAL REGULATIONS APPLICABLE TO CARGO RESTRAINT USING WEB STRAPS.
6. WHEN USING STRAPS AND WINCHES FOR CARGO RESTRAINT, THE STRAPS WILL BE TENSIONED UNTIL TIGHT WITHOUT CAUSING DAMAGE TO THE CARGO. ONLY WINCH BARS WILL BE USED FOR OPERATING THE STRAP WINCHES.
7. BEFORE AND DURING INSTALLATION, THE WEB STRAP ASSEMBLIES SHALL BE INSPECTED FOR DEFECTS. STRAPS HAVING ANY OF THE FOLLOWING DEFECTS WILL NOT BE USED FOR THE RESTRAINT OF ANY AMMUNITION LOAD, WITH THE EXCEPTION OF ONE WITH FRAYED ENDS. A STRAP HAVING FRAYED ENDS CAN BE USED IF THE FRAYEDEND IS TRIMMED AND MELTED WITH HEAT OR FLAME UNTIL ALL STRANDS ARE SEIZED.
 - A. STRAP ASSEMBLY HARDWARE: SHALL BE INSPECTED FOR BENT HOOKS, GOUGES, CORROSION, SIGNS OF REPAIR, BENT RATCHETS OR WINCHES, WEAR, OR ANY OTHER NOTICEABLE DEFECTS.
 - B. STRAP WEBBING: SHALL BE INSPECTED FOR KNOTS, EXCESSIVE ABRASIVE WEAR, TEARS, PUNCTURES, CUTS, ACID OR CAUSTIC BURNS, BROKEN STITCHES, FRAYED ENDS, OIL OR GREASE SPOTS EXCEEDING 6 SQUARE INCHES, BLEACHING OF COLOR, INCREASED STIFFNESS, SPLICES, VISIBLE WEAR INDICATOR THREADS, OR ANY OTHER NOTICEABLE DEFECTS.
8. RATCHET HANDLES MUST BE IN THE LOCKED POSITION AND/OR WINCH LOCKING DEVICES MUST BE FULLY SEATED IN THE TEETH OF THE WINCH.
9. IF THE WINCHES BEING USED ARE THE REMOVABLE TYPE HAVING BOLTS FOR ATTACHMENT TO THE TRAILER, CARE MUST BE EXERCISED WHEN ATTACHING THE WINCHES TO THE TRAILER. IF EXCESSIVE FORCE IS EXERTED ON THE BOLT DURING TENSIONING, DEFORMATION OF THE WINCH BRACKET MAY OCCUR, AND SUBSEQUENTLY CAUSE FAILURE OF THE WINCH BRACKET DURING TRANSPORT. WINCHES MUST BE FASTENED TO THE TRAILER WITH A MINIMUM OF TWO BOLTS.

(SPECIAL PROVISIONS CONTINUED AT RIGHT)

BILL OF MATERIAL		
LUMBER	LINEAR FEET	BOARD FEET
2" X 4"	14	10
2" X 6"	72	72
NAILS	NO. REQD	POUNDS
10d (3")	190	3
20d (4")	18	3/4
STEEL STRAPPING, 1-1/4" ----- 578' REQD ----- 83 LBS		
SEAL FOR 1-1/4" STRAPPING ---- 68 REQD ----- 3-1/4 LBS		
WEB STRAP ASSEMBLIES ----- 10 REQD		

SPECIAL NOTES:

1. A 22-CONTAINER LOAD IS SHOWN ON A 40'-0" LONG BY 8'-0" WIDE FLATBED TRAILER. TRAILERS OF OTHER LENGTHS CAN BE USED.
2. THE PROCEDURES DEPICTED ON PAGES 12 AND 13 CAN BE USED FOR ANY OF THE LOADS SHOWN HEREIN.
3. IF DESIRED, AND IF THE CAPACITY OF THE FORKLIFT TRUCK PERMITS, STACKS OF TWO CONTAINERS MAY BE UNITIZED WITH TWO STEEL STRAPS PRIOR TO PLACEMENT ON THE TRAILER.

(SPECIAL PROVISIONS FOR WEB STRAP TIEDOWN CONTINUED)

10. DRIVERS MUST BE INSTRUCTED TO PERIODICALLY CHECK THE TIGHTNESS OF THE WEB STRAP ASSEMBLIES AND RE-TIGHTEN, IF NECESSARY.
11. IF PROVIDED ON OR WITH THE WEB STRAP ASSEMBLIES, SCUFF SLEEVES/WEB PROTECTORS WILL BE USED WHEREVER THE STRAP PASSES OVER A SHARP CORNER OR IRREGULAR SURFACE. IF NOT PROVIDED, ANTI-CHAFING MATERIAL OF A SUITABLE THICKNESS WILL BE USED TO INSURE THAT THE STRAP WEBBING IS NOT DAMAGED DURING TRANSPORT OF THE LOAD.
12. THE HARDWARE FITTING OF THE TIEDOWN ASSEMBLIES MUST BE ATTACHED TO THE TRAILER IN SUCH A MANNER THAT THEY WILL REMAIN IN PLACE IF SLACK DEVELOPS IN THE STRAP DURING TRANSPORT.

LOAD AS SHOWN

ITEM	QUANTITY	WEIGHT (APPROX)
CONTAINER -----	22 -----	40,810 LBS
DUNNAGE -----		254 LBS
TOTAL WEIGHT -----		41,064 LBS (APPROX)

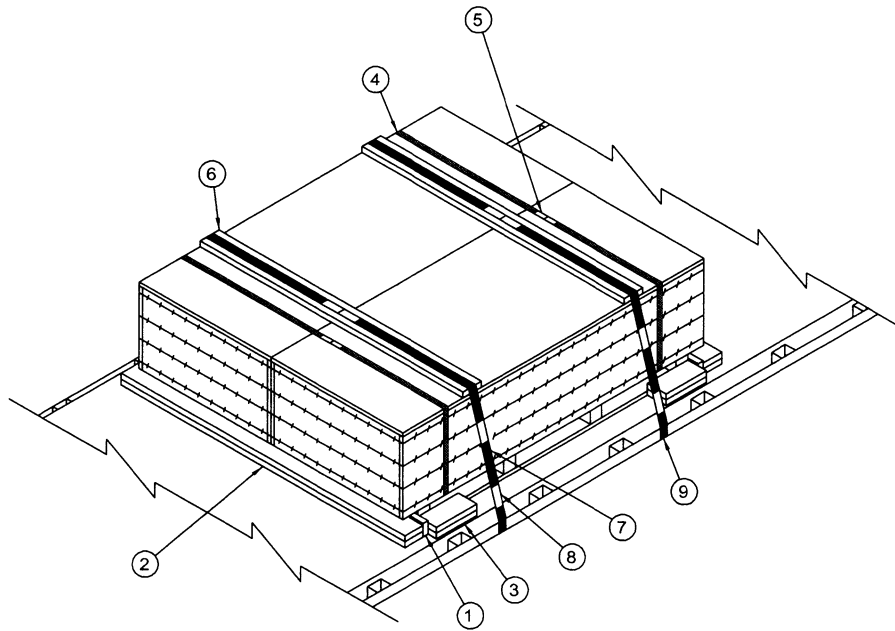

ISOMETRIC VIEW

SPECIAL NOTES:

1. A 2-CONTAINER LOAD IS SHOWN. HOWEVER, THE PROCEDURES CAN ALSO BE USED FOR SHIPMENT OF A 1-CONTAINER LOAD AS FOLLOWS:
 - A. OMIT PIECES MARKED ④ AND ⑤.
 - B. USE PIECE MARKED ⑧ AND ⑨ AS SPECIFIED.
 - C. REDUCE THE LENGTH OF THE TWO FILL PIECES MARKED ① AND THE TWO HEADERS MARKED ②, TO 45".
 - D. REDUCE THE LENGTH OF THE TWO STRAPPING BOARDS, PIECES MARKED ⑥, TO 39".
 - E. REDUCE THE LENGTH OF THE TWO HOLD-DOWN STRAPS, PIECES MARKED ⑦, TO 19'-0".
2. REFER TO THE "SPECIAL PROVISIONS FOR CHAIN TIEDOWN" ON PAGE 11 OR THE "SPECIAL PROVISIONS FOR WEB STRAP TIEDOWN ON PAGE 13 FOR THE USE OF EITHER CHAINS OR WEB STRAPS IN LIEU OF STEEL STRAPPING.

KEY NUMBERS

- ① FILL PIECE, 2" X 4" X 7'-0" (2 REQD). POSITION ON EDGE AGAINST CONTAINER BASE. NAIL TO THE HEADER W/1-10d NAIL AT EACH END.
- ② HEADER, 2" X 6" X 7'-0" (DOUBLED) (2 REQD). POSITION AGAINST THE FILL PIECE AND NAIL THE FIRST PIECE TO THE TRAILER FLOOR W/5-10d NAILS. NAIL THE SECOND PIECE TO THE FIRST W/5-20d NAILS. SEE GENERAL NOTE "J" ON PAGE 2.
- ③ SIDE BLOCKING, 2" X 6" X 12" (DOUBLED) (4 REQD). POSITION AT EACH END OF THE CONTAINER BASE AND NAIL THE FIRST PIECE TO THE TRAILER FLOOR W/4-10d NAILS. NAIL THE SECOND PIECE TO THE FIRST IN A LIKE MANNER.
- ④ BUNDLING STRAP, 1-1/4" X .035" OR .031" X 18'-6" LONG STEEL STRAPPING (2 REQD). INSTALL SO AS TO ENCIRCLE THE LATERALLY ADJACENT UNITS AS SHOWN.
- ⑤ SEAL FOR 1-1/4" STRAPPING (4 REQD, 2 PER STRAP). DOUBLE CRIMP EACH SEAL. SEE GENERAL NOTE "K" ON PAGE 2.
- ⑥ STRAPPING BOARD, 2" X 6" X 6'-6" (2 REQD).
- ⑦ HOLD-DOWN STRAP, 2" X .050" OR .044" X 21'-0" LONG STEEL STRAPPING (2 REQD). INSTALL EACH STRAP FROM TWO 10'-6" LONG PIECES. STAPLE THE A STRAP TO PIECE MARKED ⑥ W/1-STAPLE AT EACH END. SEE THE "END-OVER-END LAP JOINT DETAILS" ON PAGE 15.
- ⑧ SEAL FOR 2" STRAPPING (12 REQD, 6 PER STRAP). DOUBLE CRIMP EACH SEAL, EXCEPT THOSE USED TO SECURE THE PADS, PIECES MARKED ⑨.
- ⑨ PAD, 2" X .050" OR .044" X 18" LONG STEEL STRAPPING (4 REQD). POSITION UNDER STAKE POCKET OR RUB RAIL AND SEAL TO THE HOLD-DOWN STRAP. ALT: STAKE POCKET PROTECTOR (8 REQD). USE TWO UNDER EACH STAKE POCKET WITH A HOLD-DOWN STRAP.

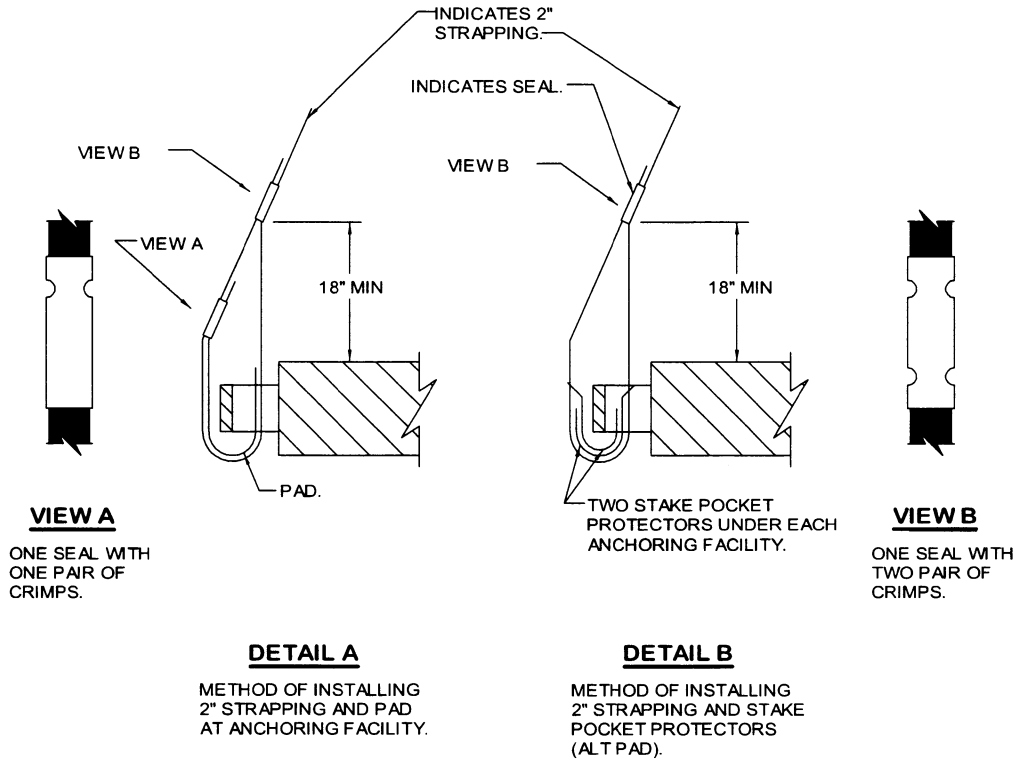

HOLD-DOWN STRAP ANCHORING DETAILS

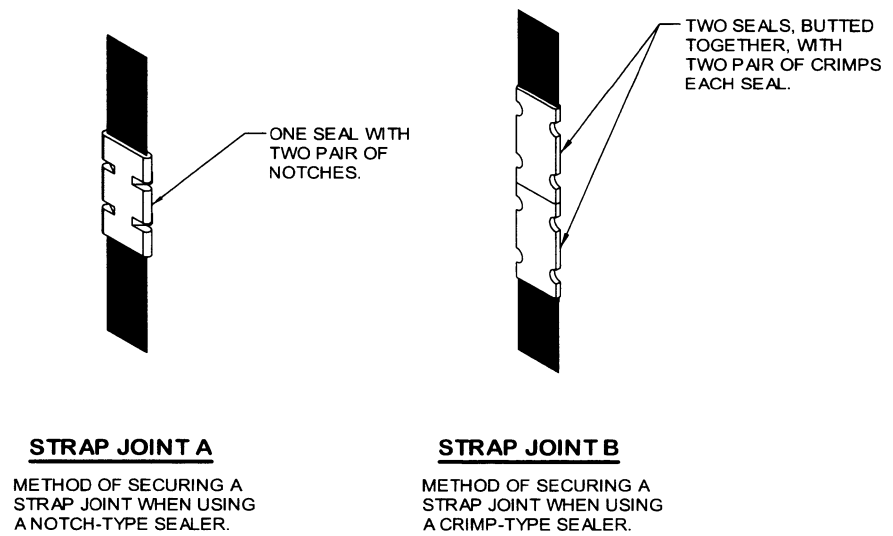

END-OVER-END LAP JOINT DETAILS

**PROVISIONS FOR THE USE OF FIREHOSE IN LIEU
OF CHAIN BOARDS OR STRAPPING BOARDS**

FIRE HOSE THAT IS NO LONGER SUITABLE FOR USE IN FIRE FIGHTING APPLICATIONS CAN BE SUBSTITUTED FOR THE DOUBLED 2" BY 6" WOODEN CHAIN BOARDS OR SINGLE 2" BY 6" STRAPPING BOARDS, AS SPECIFIED HEREIN, PROVIDED THE FOLLOWING CONDITIONS ARE MET.

1. SUBSTITUTION AND APPLICATION GUIDANCE

- A. FIRE HOSE MAY BE USED WHEREVER A CHAIN OR STRAPPING BOARD CONTACTS A RIGID SURFACE OF THE LOAD PROVIDED GOUGING, SCRATCHING, CRACKING, BENDING, CRUSHING, OR OTHER VISIBLE DAMAGE DOES NOT OCCUR TO THE LOAD.
- B. ONE OR MORE SEGMENTS OF FIRE HOSE MAY BE USED TO REPLACE EACH CHAIN OR STRAPPING BOARD PROVIDING LOAD PROTECTION DURING TENSIONING OF TIEDOWNS AND LOAD SHIPMENT; I.E., A CHAIN BOARD NEED NOT BE REPLACED BY A SINGLE SEGMENT OF HOSE, MULTIPLE SEGMENTS MAY BE USED INSTEAD, AS LONG AS THEY ARE SECURELY FASTENED TO THE TIEDOWN. REGARDLESS OF THE NUMBER OF SEGMENTS USED, THE HOSE LENGTH WILL BE SUCH THAT IT EXTENDS AT LEAST 6" BEYOND THE EDGE OF THE LOAD.
- C. FIRE HOSE CANNOT BE USED IN PLACE OF A PURCHASE BOARD ON A LOAD CONSISTING OF MORE THAN TWO PALLETS OR CONTAINERS ACROSS THE WIDTH OF THE TRAILER. THE FIRE HOSE CAN BE APPLIED TO THE OUTER STACKS, HOWEVER, A PURCHASE BOARD ASSEMBLY WILL STILL BE REQUIRED TO PROVIDE VERTICAL HOLD-DOWN ON THE CENTER STACK(S).

2. ACCEPTABLE FIRE HOSE

- A. FIRE HOSE TO BE USED WILL BE A RUBBER LINED SINGLE OR DOUBLE JACKETED TYPE; I.E., IT MUST HAVE A RUBBER LINING INSIDE A SINGLE OR DOUBLED FABRIC (COTTON, LINEN, ETC.) JACKET.
- B. THE COLLAPSED WIDTH OF THE HOSE MUST BE A MINIMUM OF 2-1/2".
- C. THE HOSE SEGMENTS USED MUST NOT CONTAIN DEFECTS THAT WILL ALLOW DIRECT CONTACT OF THE CHAIN OR LOAD BINDER WITH THE LOAD. THE HOSE THICKNESS MUST ALSO BE OF SUCH A THICKNESS THAT DENTING OR DAMAGE TO THE LOAD DOES NOT OCCUR DURING CHAIN OR STRAP TENSIONING.

4. SECUREMENT TO CHAINS OR STRAPS

- A. THE SEGMENTS OF HOSE USED UNDER EACH CHAIN OR STRAP WILL BE SECURED TO THE CHAIN OR STRAP WITH ONE FASTENER EVERY 12", WITH A MINIMUM OF TWO FASTENERS REQUIRED PER HOSE SEGMENT.
- B. FASTENERS CAN CONSIST OF PLASTIC ELECTRICAL TIES, NO. 14 GAGE WIRE, OR TAPE. REGARDLESS OF THE TYPE OF FASTENING USED, IT MUST PROVIDE A POSITIVE MEANS OF SECUREMENT OF THE HOSE TO THE CHAIN OR STRAP AND MUST NOT DAMAGE THE SURFACE OF THE CONTAINER, PALLET, OR ITEM IT CONTACTS.