

⊕ n / Hed

DATE 6-25-98

LOADING AND BRACING[⊕] IN MILVAN CONTAINERS[⊕] OF 2.75 INCH HYDRA ROCKETS PACKED IN CYLINDRICAL METAL CONTAINERS

PA151 SERIES CONTAINERS

INDEX

ITEM	PAGE(S)
TYPICAL LOADING PROCEDURES - - - - -	2
GENERAL NOTES AND MATERIAL SPECIFICATIONS - - - - -	3
PALLET UNIT DETAIL - - - - -	4
DETAILS - - - - -	4-7
LESS-THAN-FULL-LOAD DETAILS - - - - -	8

● LOADING AND BRACING SPECIFICATIONS SET FORTH WITHIN THIS DRAWING ARE APPLICABLE TO LOADS THAT ARE TO BE SHIPPED BY TRAILER/CONTAINER-ON-FLATCAR (T/COFC) RAIL CARRIER SERVICE. THESE SPECIFICATIONS MAY ALSO BE USED FOR LOADS THAT ARE TO BE MOVED BY MOTOR OR WATER CARRIERS.

⊕ ONLY MILVAN CONTAINERS WHICH HAVE BEEN MODIFIED TO INCLUDE A MECHANICAL LOAD-BRACING SYSTEM THAT SATISFIES THE REQUIREMENTS OF THE BUREAU OF EXPLOSIVES PAMPHLET 6C WILL BE USED FOR THE MOVEMENT OF AMMUNITION BY T/COFC SERVICE. CAUTION: OTHER REQUIREMENTS OF PAMPHLET 6C ALSO APPLY.

U.S. ARMY MATERIEL COMMAND DRAWING

APPROVED, U.S. ARMY INDUSTRIAL OPERATIONS COMMAND <i>[Signature]</i>	ENGINEER	BASIC	LAURA FIEFFER	DO NOT SCALE			
		REV.		WEBSITE: HTTP://WWW.DAC.ARMY.MIL			
	TECHNICIAN	BASIC		MARCH 1998			
	REV.						
	DRAFTSMAN	BASIC					
		REV.					
APPROVED BY ORDER OF COMMANDING GENERAL, U.S. ARMY MATERIEL COMMAND <i>William F Ernst</i> U.S. ARMY DEFENSE AMMUNITION CENTER	TRANSPORTATION ENGINEERING DIVISION		<i>W. R. Frenick</i>				
	VALIDATION ENGINEERING DIVISION		<i>[Signature]</i> TESTED	CLASS	DIVISION	DRAWING	FILE
	LOGISTICS ENGINEERING OFFICE		<i>William F Ernst</i>	19	48	4244/ 61	15PM1008

* THE 2-LAYER LOAD DEPICTED BELOW IS BASED ON A 43" TALL PALLET UNIT AND A 87" INTERIOR HEIGHT OF THE MILVAN. PRIOR TO LOADING, A FIELD CHECK SHOULD BE MADE TO DETERMINE THE ACTUAL PALLET UNIT STACK HEIGHT AND THE ACTUAL INTERIOR HEIGHT OF THE MILVAN. IF THE 2-LAYER STACK CANNOT BE LOADED DUE TO MILVAN ROOF BOWS OR PALLET STACKING LUGS, ONE LAYER SHOULD BE OMITTED, FOR A 1-LAYER, EIGHT PALLET UNIT LOAD.

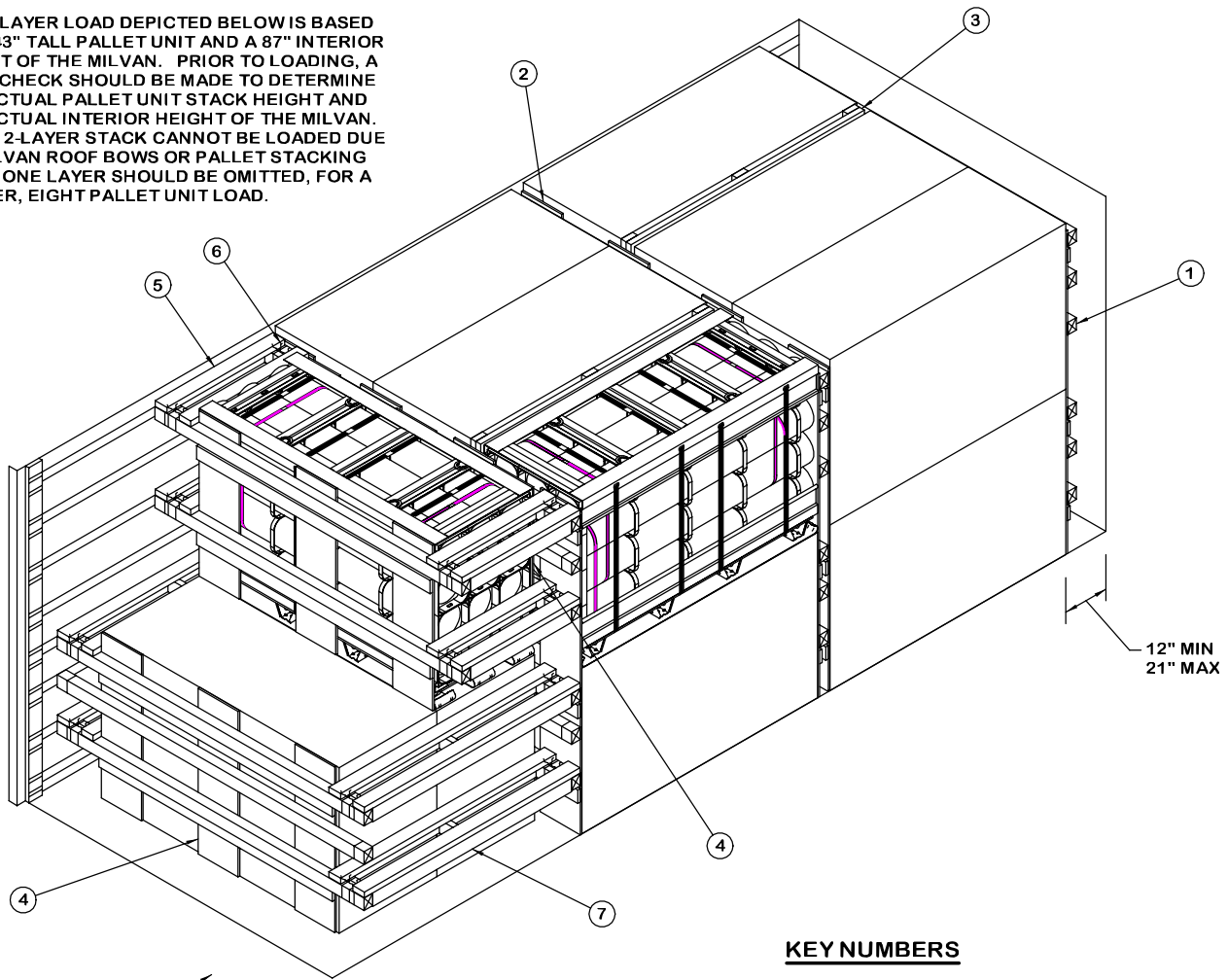

REAR OF CONTAINER. →

ISOMETRIC VIEW

KEY NUMBERS

- ① CROSS MEMBER (23 REQD). POSITION AS SHOWN IN THE DETAIL ABOVE, AT THE 16", 28", 38", 60", 72" AND 83" HEIGHTS. SEE THE "FILL DETAIL" ON PAGE 4.
- ② LENGTHWISE LOAD BEARING GATE (4 REQD). SEE THE DETAIL ON PAGE 5.
- ③ CENTER FILL ASSEMBLY (2 REQD). SEE THE DETAIL ON PAGE 6.
- ④ CROSSWISE LOAD BEARING GATE (1 TWO HIGH AND 2 ONE HIGH REQD). SEE THE DETAIL ON PAGE 5.
- ⑤ SPACER ASSEMBLY A (4 REQD). SEE THE DETAIL ON PAGE 7.
- ⑥ TIE WIRE, 18" LONG (32 REQD, 4 PER SPACER ASSEMBLY). INSTALL TO FORM A COMPLETE LOOP AROUND THE CROSS MEMBER AND THE SPACER ASSEMBLY. BRING ENDS TOGETHER AND TWIST TAUT. SECURE WITH A PARTIALLY DRIVEN 10d NAIL BENT OVER THE WIRE OR WITH A STRAP STAPLE.
- ⑦ SPACER ASSEMBLY B (4 REQD). SEE THE DETAIL ON PAGE 7.

BILL OF MATERIAL		
LUMBER	LINEAR FEET	BOARD FEET
1" x 4"	132	44
2" x 4"	227	152
NAILS	NO. REQD	POUNDS
6d (2")	276	1-3/4
10d (3")	208	3-1/4
PLYWOOD, 1/2"	154.50 SQ FT REQD	212.44 LBS
WIRE	48 FT REQD	0.80 LBS
STAPLE	32 REQD	0.23 LBS
CROSS MEMBER		23 REQD

LOAD AS SHOWN*

ITEM	QUANTITY	WEIGHT (APPROX)
PALLET UNIT	15	30,435 LBS
DUNNAGE		611 LBS
CONTAINER		5,700 LBS
TOTAL WEIGHT		36,746 LBS (APPROX)

L. MAXIMUM LOAD WEIGHT CRITERIA:

THE MAXIMUM LOAD WEIGHTS ARE CONTROLLED BY EQUIPMENT CAPABILITY FACTORS. ALTHOUGH THE HEAVIEST MAXIMUM LOADS ARE DELINEATED IN THE LOAD VIEWS, PROVISIONS ARE INCLUDED WITHIN THIS DRAWING SO THAT THE BASIC LOADS CAN BE ADJUSTED TO SATISFY A LESSER QUANTITY OF LADING UNITS. DEPENDING ON TRANSPORTATION ROUTING, IT MAY BE NECESSARY TO REDUCE THE LOAD WEIGHT TO SATISFY "WEIGHT LAWS" OF CERTAIN STATES. ALSO, IT MAY BE NECESSARY TO REDUCE THE LOAD WEIGHT TO SATISFY OTHER WEIGHT RESTRICTIONS IMPOSED ON THE INTERMODAL CONTAINER SYSTEM.

M. SPECIAL T/COFC NOTES:

- 1. CAUTION: LOADED CONTAINERS MUST BE ON CHASSIS EQUIPPED WITH TWO BOGIE ASSEMBLIES WHEN BEING MOVED IN TOFC SERVICE, REGARDLESS OF THE LOAD WEIGHT WITHIN THE CONTAINER.
- 2. LOAD LIMITS OF T/COFC RAIL CARS MUST NOT BE EXCEEDED, NOR WILL A CAR BE LOADED SO THAT THE TRUCK UNDER ONE END OF THE CAR CARRIES MORE THAN ONE-HALF OF THE LOAD LIMIT FOR THAT CAR.
- 3. CHASSIS/CONTAINERS COUPLED INTO A 40-FOOT TRAILER CONFIGURATION MUST BE PLACED AT THE B-END OF A TOFC RAIL CAR. THE REAR END OF THE 40-FOOT UNIT WILL OVERHANG THE END OF THE CAR IF IT IS PLACED AT THE A-END. TWENTY-FOOT AND 40-FOOT UNITS CAN BE LOADED ON THE SAME CAR.

N. WHEN LOADING CONTAINERS, THEY ARE TO BE POSITIONED SO AS TO ACHIEVE A TIGHT LOAD (TIGHT AGAINST THE DUNNAGE ASSEMBLIES). THE UNBLOCKED SPACE ACROSS THE WIDTH OF A LOAD BAY IS NOT TO EXCEED 1-1/2". EXCESSIVE SLACK CAN BE ELIMINATED BY LAMINATING ADDITIONAL PIECES OF APPROPRIATE THICKNESS TO THE HORIZONTAL PIECES ON THE CENTER FILL ASSEMBLIES. NAIL EACH ADDITIONAL PIECE TO THE HORIZONTAL PIECE W/1 APPROPRIATELY SIZED NAIL EVERY 12". ADDITIONALLY, THE THICKNESS OF THE HORIZONTAL AND/OR VERTICAL PIECES IN THE CENTER FILL ASSEMBLY MAY BE ADJUSTED, AS NECESSARY, TO FACILITATE VARIANCE IN THE PALLET UNIT SIZE.

O. WHETHER A CONTAINER IS FULL OR IS LOADED WITH A REDUCED QUANTITY OF LADING UNITS, THE LENGTHWISE CENTER OF GRAVITY OF THE LOAD MUST BE WITHIN 12", IN EITHER DIRECTION, OF THE MID-POINT OF THE CONTAINER.

P. THE QUANTITY OF PALLET UNITS SHOWN IN THE LOAD ON PAGE 2 MAY BE REDUCED FOR SHIPMENT, IF DESIRED. SEE THE "LESS-THAN-FULL LOAD" DETAIL ON PAGE 8.

A. THIS DOCUMENT HAS BEEN PREPARED AND ISSUED IN ACCORDANCE WITH AR 740-1 AND AUGMENTS TM 743-200-1 (CHAPTER 5).

B. THE SPECIFIED OUTLOADING PROCEDURES ARE APPLICABLE TO LOADS OF 2.75 INCH HYDRA ROCKETS PACKED IN PA151 CYLINDRICAL METAL CONTAINERS. SUBSEQUENT REFERENCE TO PALLET UNIT HEREIN MEANS THE PALLET UNIT WITH ROCKETS. SEE PAGE 4 AND AMC DRAWING 19-48-4231/61-20PM1006 FOR DETAILS OF THE PALLET UNIT. CAUTION: REGARDLESS OF THE QUANTITY OF UNITS TO BE SHIPPED, THE "MAXIMUM GROSS WEIGHT" OF THE MILVAN MUST NOT BE EXCEEDED.

C. THE LOADS AS SHOWN ARE BASED ON A 20' LONG BY 8' WIDE BY 8' HIGH MILVAN CONTAINER WITH INSIDE DIMENSIONS OF 19'-4" LONG BY 92" WIDE BY 87" HIGH. THE LOADS ARE DESIGNED FOR TRAILER/CONTAINER-ON-FLATCAR (T/COFC) SHIPMENT.

D. THE SPECIFIED OUTLOADING PROCEDURES ARE FOR CONTAINERS EQUIPPED WITH SELF-CONTAINED MECHANICAL BRACING DEVICES AS DESCRIBED IN MIL-C-52661. CROSS MEMBER ATTACHMENT FACILITIES WITHIN THESE CONTAINERS MUST PROVIDE FOR THE INSTALLATION OF LOAD BLOCKING CROSS MEMBERS AT THE HEIGHTS SPECIFIED. VOIDS LENGTHWISE WITHIN THE LOAD MUST BE HELD TO A MINIMUM. CROSS MEMBERS MUST BE PLACED AGAINST THE LADING AS TIGHTLY AS THE HOLE SPACING IN THE CROSS MEMBER ATTACHMENT FACILITY PERMITS. SEE THE "FILL DETAIL" ON PAGE 4 FOR ADDITIONAL GUIDANCE. EACH CROSS MEMBER WILL BE INSTALLED WITH THE ENDS ATTACHED AS NEARLY AS POSSIBLE IN "MATED" POSITIONS (AT EQUAL HEIGHTS, AND AT EQUAL DISTANCES FROM THE END OF THE CONTAINER). CROSS MEMBERS IN EMPTY CONTAINERS AND THOSE NOT USED IN LOADED CONTAINERS MUST BE FASTENED INTO BELT RAILS FOR SHIPMENT. COMPONENTS ASSIGNED TO EACH CONTAINER MUST REMAIN THEREWITH EVEN THOUGH UNUSED DURING SOME SHIPMENTS. THE LOAD BLOCKING COMPONENT DESIGNATED AS "CROSS MEMBER" HEREIN IS IDENTIFIED AS "BEAM ASSEMBLY" WITHIN TM 55-8115-200-23&P, DATED DECEMBER 1979. THE BEAM ASSEMBLY IS FURTHER IDENTIFIED AS NSN 8115-00-165-6623.

E. DUNNAGE LUMBER SPECIFIED IS OF A NOMINAL SIZE. FOR EXAMPLE, 1" X 4" MATERIAL IS ACTUALLY 3/4" THICK BY 3-1/2" WIDE AND 2" X 6" MATERIAL IS ACTUALLY 1-1/2" THICK BY 5-1/2" WIDE.

F. CAUTION: DO NOT NAIL DUNNAGE MATERIAL TO THE MILVAN WALLS OR FLOOR. ALL NAILING WILL BE WITHIN THE DUNNAGE.

G. A STAGGERED NAILING PATTERN WILL BE USED WHENEVER POSSIBLE WHEN NAILS ARE DRIVEN INTO JOINTS OF DUNNAGE ASSEMBLIES OR WHEN LAMINATING DUNNAGE. ADDITIONALLY, THE NAILING PATTERN FOR AN UPPER PIECE OF LAMINATED DUNNAGE WILL BE ADJUSTED AS REQUIRED SO THAT A NAIL FOR THAT PIECE WILL NOT BE DRIVEN THROUGH ONTO OR RIGHT BESIDE A NAIL IN A LOWER PIECE.

H. PORTIONS OF THE MILVAN DEPICTED WITHIN THIS DRAWING, SUCH AS ONE OF THE SIDEWALLS, HAVE NOT BEEN SHOWN IN THE LOAD VIEWS FOR CLARITY PURPOSES.

J. CONVERSION TO METRIC EQUIVALENTS: DIMENSIONS WITHIN THIS DOCUMENT ARE EXPRESSED IN INCHES, AND WEIGHTS ARE EXPRESSED IN POUNDS. WHEN NECESSARY, THE METRIC EQUIVALENTS MAY BE COMPUTED ON THE BASIS OF ONE INCH EQUALS 25.4MM AND ONE POUND EQUALS 0.454 KG.

K. TO MAKE LOADING EASIER, TO HELP ACHIEVE A TIGHT LOAD ACROSS A CONTAINER, AND TO PREVENT UNACCEPTABLE DAMAGE TO LADING UNITS WHEN LOADING A MILVAN, A SLIP-SHEET CAN BE USED EFFECTIVELY AS A "SHOEHORN" TYPE DEVICE. THE SLIP-SHEET WILL PROVIDE A SMOOTH SURFACE THAT WILL PREVENT UNIT STRAPS AND/OR CONTAINERS FROM INTERLOCKING OR CATCHING ON OTHER PROJECTIONS WHEN LATERALLY ADJACENT LADING UNITS ARE BEING LOADED. A SLIP-SHEET WILL BE USED AFTER ONE-PALLET UNIT OF A STACK IS LOADED WITH ONE OF ITS SIDES IN TIGHT CONTACT AT ONE SIDE OF THE MILVAN OR AN ADJACENT PALLET UNIT. THE SLIP-SHEET IS TO BE PLACED AGAINST THE OTHER SIDE OF PALLET UNIT BEFORE THE NEXT PALLET UNIT IS LOADED. AFTER A STACK IS COMPLETED, THE SLIP-SHEET IS TO BE REMOVED FOR SUBSEQUENT USE WITH THE NEXT STACK. A SLIP-SHEET OF SUITABLE SIZE CAN BE MADE FROM A SHEET OF 1/8" TEMPERED HARDBOARD (MASONITE) OR FROM A SHEET OF ANY OTHER MATERIAL THAT WILL SATISFY THE REQUIREMENTS.

(CONTINUED AT LEFT)

MATERIAL SPECIFICATIONS

- LUMBER - - - - : SEE TM 743-200-1 (DUNNAGE LUMBER) AND VOLUNTARY PRODUCT STANDARD PS 20
- NAILS - - - - : ASTM F1667; COMMON STEEL NAIL (NLCMS OR NLCMS).
- PLYWOOD - - - - : COMMERCIAL ITEM DESCRIPTION A-A-55057, INDUSTRIAL PLYWOOD, INTERIOR WITH EXTERIOR GLUE, GRADE C-D. IF SPECIFIED BETTER INTERIOR OR AN EXTERIOR GRADE MAY BE SUBSTITUTED.
- WIRE,
CARBON STEEL - : ASTM A853; ANNEALED AT FINISH, BLACK OXIDE FINISH, .0800" DIA, GRADE 1006 OR BETTER.
- STAPLE,
STRAP - - - - : COMMERCIAL GRADE.

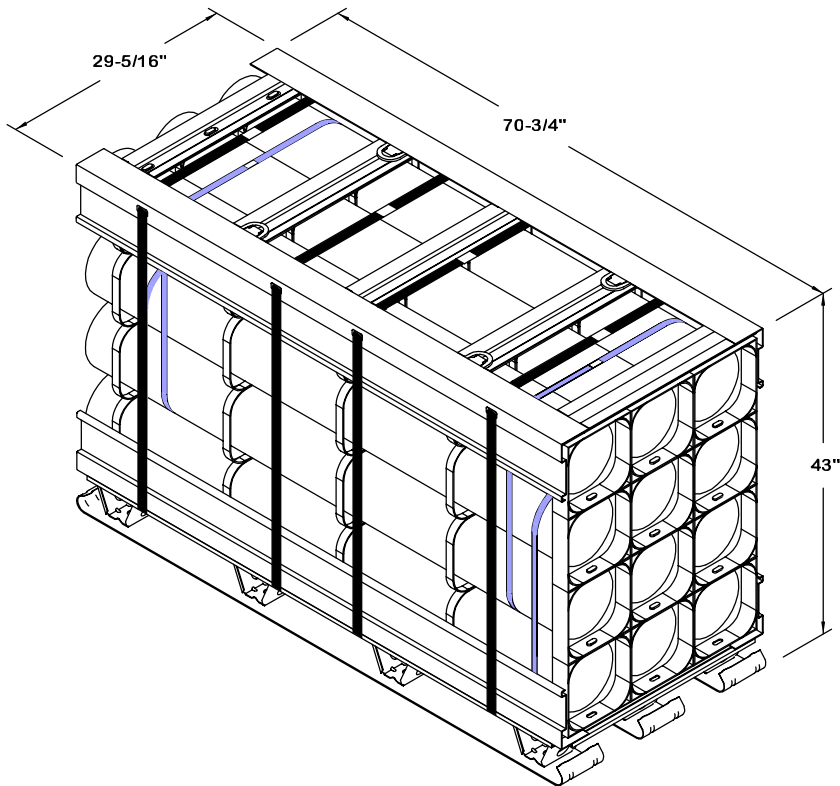

PALLET UNIT

GROSS WEIGHT - - - - - 2,029 LBS (APPROX)
 CUBE - - - - - 51.6 CUBIC FEET (APPROX)

FILL MATERIAL, 1" X 4" OR 2" X 4" MATERIAL BY CONTAINER WIDTH MINUS 1" (AS REQD).

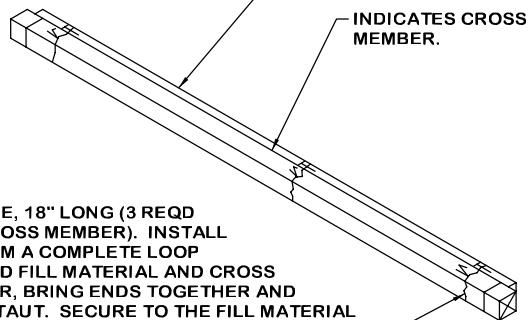

TIE WIRE, 18" LONG (3 REQD PER CROSS MEMBER). INSTALL TO FORM A COMPLETE LOOP AROUND FILL MATERIAL AND CROSS MEMBER, BRING ENDS TOGETHER AND TWIST TAUT. SECURE TO THE FILL MATERIAL WITH A PARTIALLY DRIVEN 10d NAIL BENT OVER THE WIRE, OR WITH A STRAP STAPLE.

FILL DETAIL

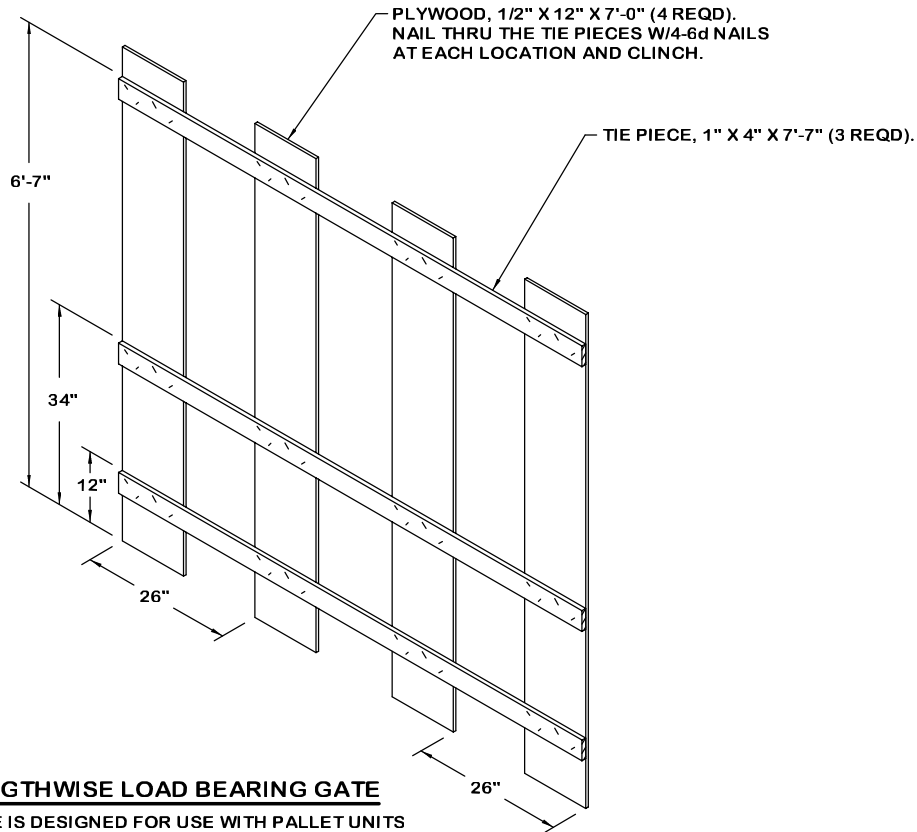

LENGTHWISE LOAD BEARING GATE

THIS GATE IS DESIGNED FOR USE WITH PALLET UNITS LOADED WITH THE 70-3/4" DIMENSION PARALLEL TO THE LENGTH OF THE ISO CONTAINER. FOR A ONE HIGH LOAD, ELIMINATE THE TOP TIE PIECE AND SHORTEN THE PLYWOOD TO 43".

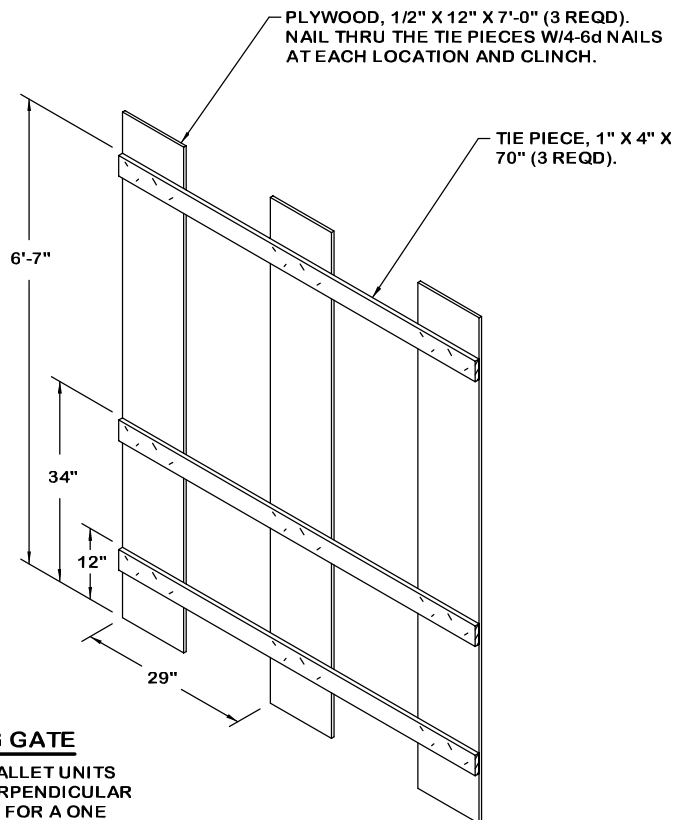

CROSSWISE LOAD BEARING GATE

THIS GATE IS DESIGNED FOR USE WITH PALLET UNITS LOADED WITH THE 70-3/4" DIMENSION PERPENDICULAR TO THE LENGTH OF THE ISO CONTAINER. FOR A ONE HIGH LOAD, ELIMINATE THE TOP TIE PIECE AND SHORTEN THE PLYWOOD TO 43".

VERTICAL PIECE, 2" X
4" X 7'-2" (3 REQD).

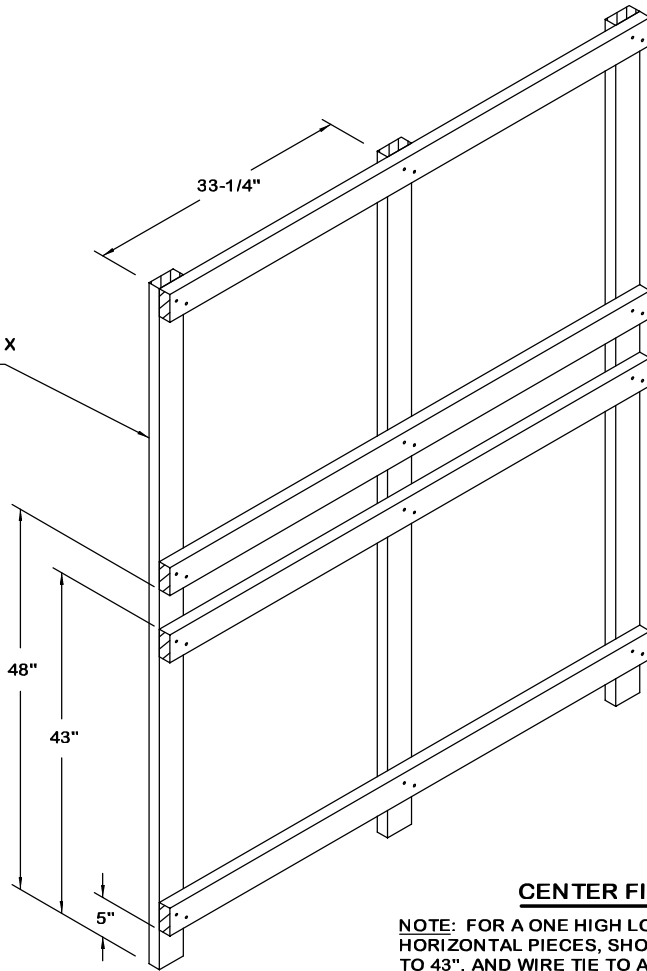

HORIZONTAL PIECE, 2" X 4" X 70"
(4 REQD). NAIL TO THE VERTICAL
PIECES W/2-10d NAILS AT EACH
JOINT.

CENTER FILL ASSEMBLY

NOTE: FOR A ONE HIGH LOAD, ELIMINATE THE TOP TWO
HORIZONTAL PIECES, SHORTEN THE VERTICAL PIECES
TO 43", AND WIRE TIE TO AN ADJACENT PALLET UNIT AT
TWO LOCATIONS.

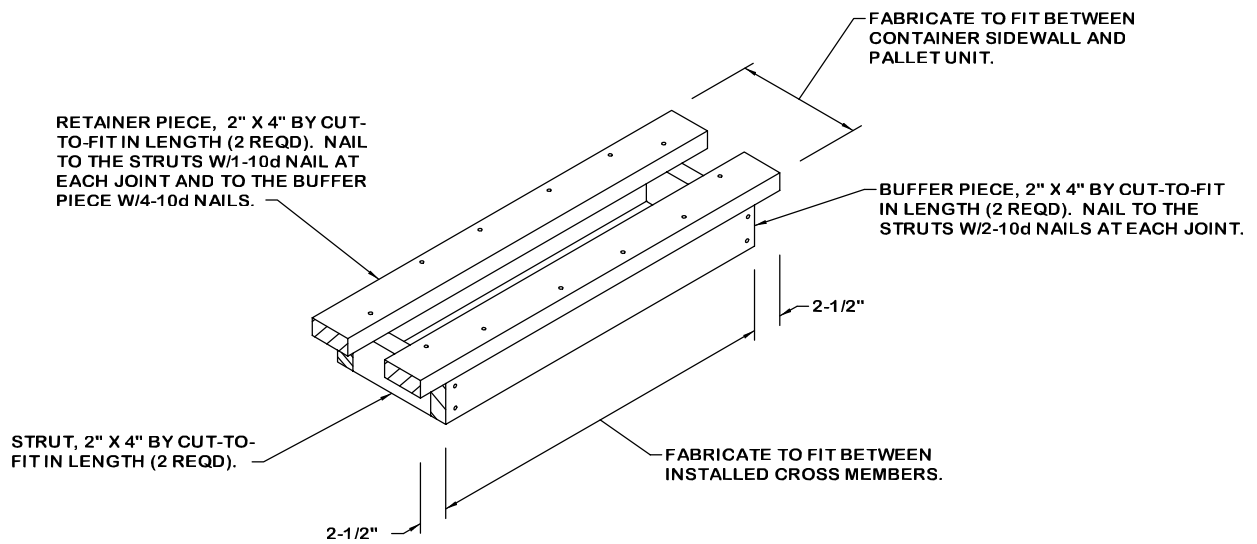

SPACER ASSEMBLY A

THIS ASSEMBLY IS FOR USE FOR BRACING ONE PALLET UNIT ORIENTED WITH THE 70-3/4" DIMENSION ACROSS THE WIDTH OF THE CONTAINER. IT MAY ALSO BE USED WITH PALLET UNITS ORIENTED WITH THE 70-3/4" DIMENSION PARALLEL TO THE LENGTH OF THE CONTAINER.

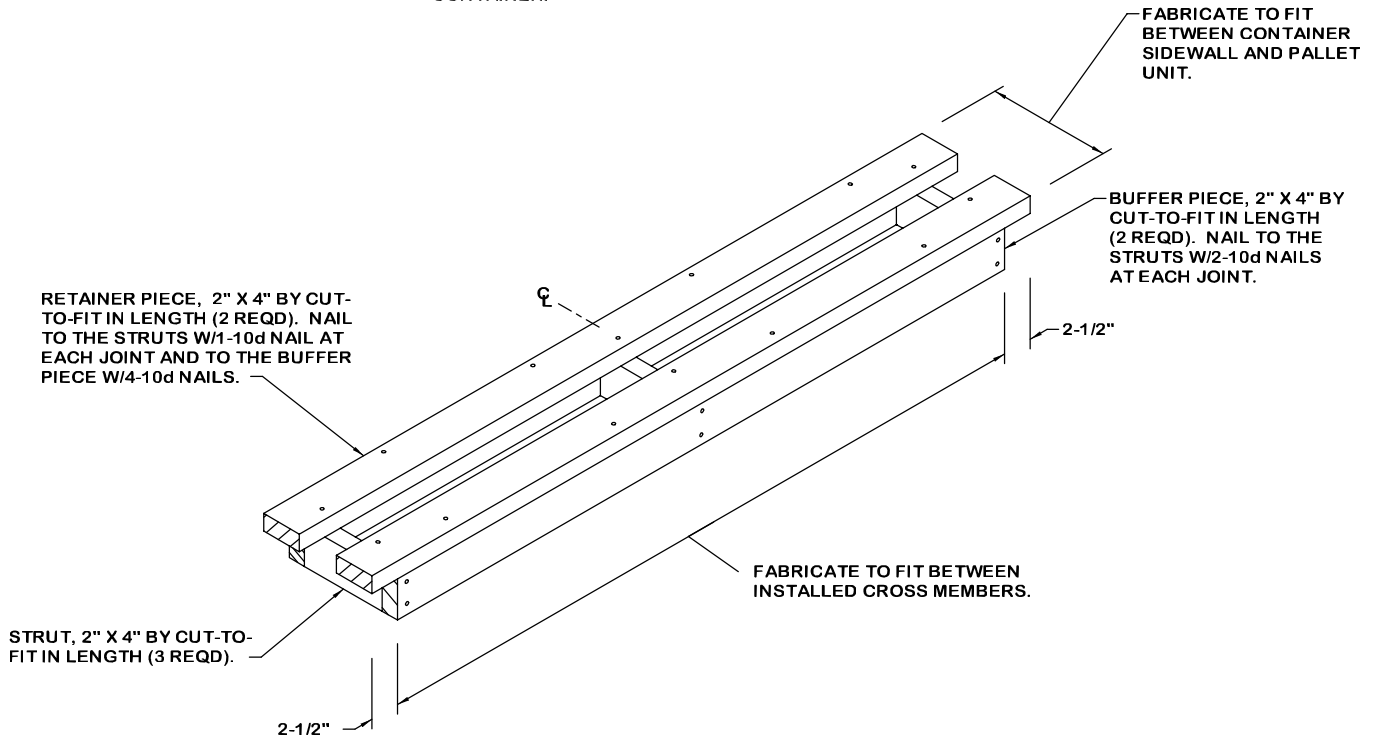

SPACER ASSEMBLY B

THIS ASSEMBLY IS FOR USE FOR BRACING TWO PALLETS UNIT ORIENTED WITH THE 70-3/4" DIMENSION ACROSS THE WIDTH OF THE CONTAINER.

TIE WIRE, 24" LONG (2 REQD PER FILLER ASSEMBLY). INSTALL TO FORM A COMPLETE LOOP AROUND THE FILLER ASSEMBLY AND A CROSS MEMBER. BRING ENDS TOGETHER AND TWIST TAUT. SECURE TO THE FILLER ASSEMBLY WITH A PARTIALLY DRIVEN 10d NAIL BENT OVER THE WIRE OR WITH A STRAP STAPLE.

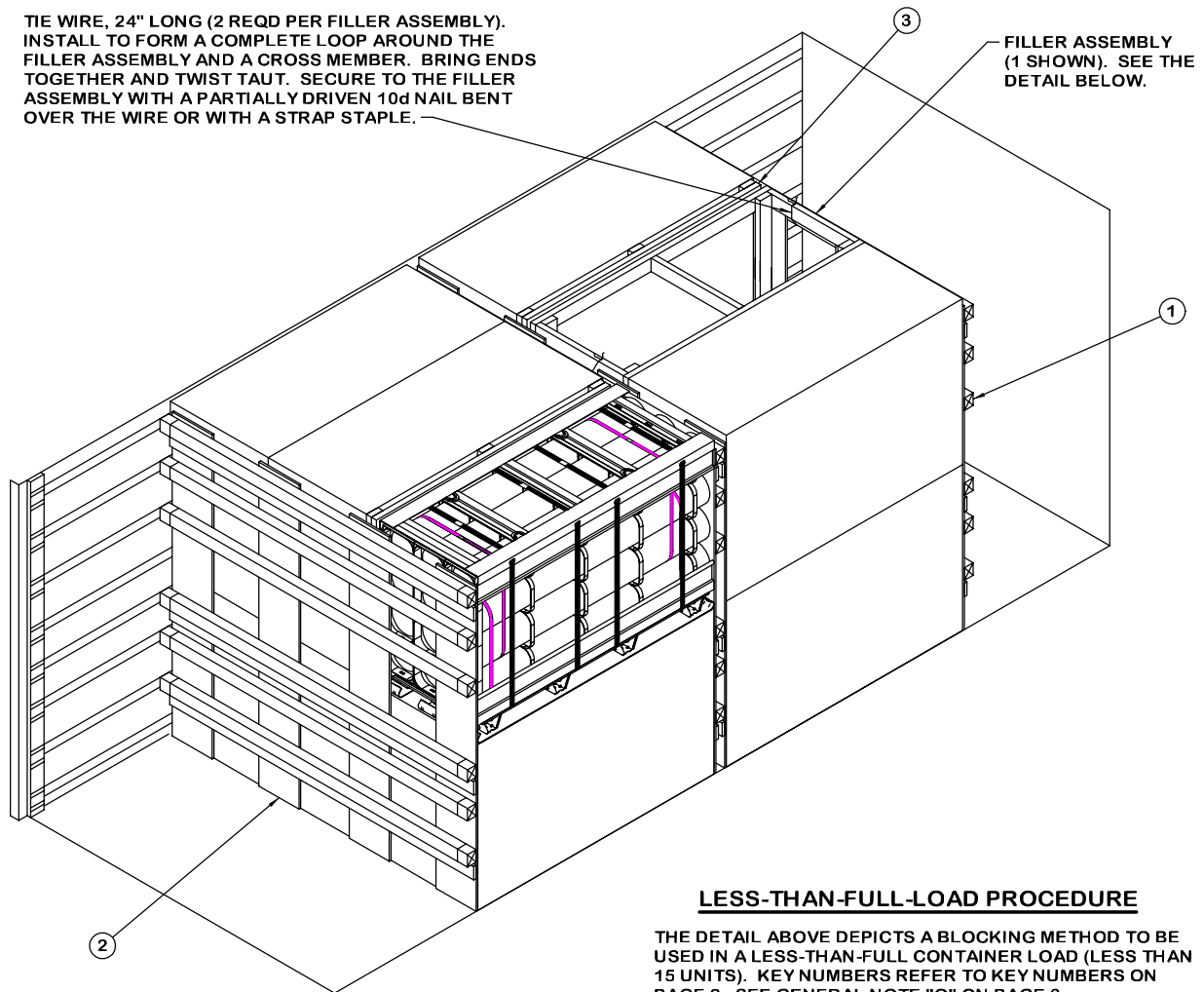

FILLER ASSEMBLY (1 SHOWN). SEE THE DETAIL BELOW.

LESS-THAN-FULL-LOAD PROCEDURE

THE DETAIL ABOVE DEPICTS A BLOCKING METHOD TO BE USED IN A LESS-THAN-FULL CONTAINER LOAD (LESS THAN 15 UNITS). KEY NUMBERS REFER TO KEY NUMBERS ON PAGE 2. SEE GENERAL NOTE "O" ON PAGE 3.

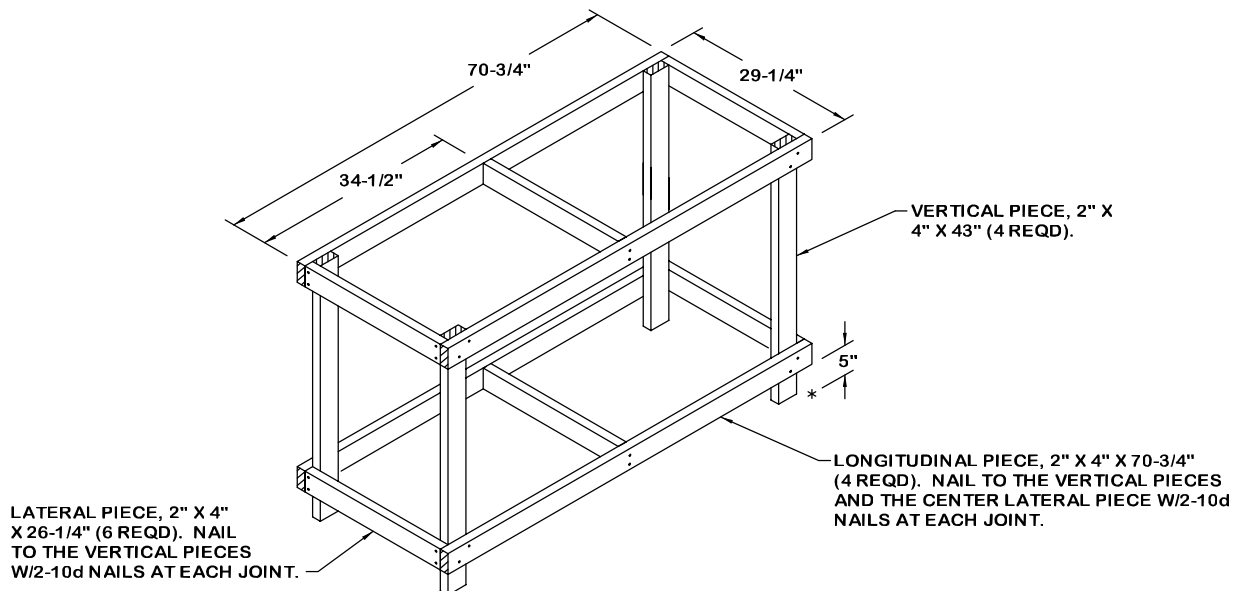

LATERAL PIECE, 2" X 4" X 26-1/4" (6 REQD). NAIL TO THE VERTICAL PIECES W/2-10d NAILS AT EACH JOINT.

VERTICAL PIECE, 2" X 4" X 43" (4 REQD).

LONGITUDINAL PIECE, 2" X 4" X 70-3/4" (4 REQD). NAIL TO THE VERTICAL PIECES AND THE CENTER LATERAL PIECE W/2-10d NAILS AT EACH JOINT.

FILLER ASSEMBLY

THE ASSEMBLY DEPICTED ABOVE IS FOR USE IN PLACE OF AN OMITTED PALLET UNIT. FILLER ASSEMBLIES MUST BE WIRE TIED TO CROSS MEMBERS TO PREVENT UNDUE MOVEMENT. NO MORE THAN TWO FILLER ASSEMBLIES WILL BE USED IN ANY LOAD.