

# LOADING AND BRACING\* IN MILVAN CONTAINERS<sup>⊗</sup> OF M93 WIDE AREA MUNITION (WAM), OR M98 WAM TRAINER, PACKED IN PA160 CYLINDRICAL METAL CONTAINERS

## INDEX

ITEM	PAGE(S)
TYPICAL LOADING PROCEDURES - - - - -	2
GENERAL NOTES AND MATERIAL SPECIFICATIONS - - - - -	3
PALLET UNIT DETAILS - - - - -	4
DETAILS - - - - -	4-5
LESS-THAN-FULL-LOAD PROCEDURE - - - - -	6

\*THE PROCEDURES SHOWN HEREIN ARE APPLICABLE TO LOADS THAT ARE TO BE SHIPPED BY TRAILER/CONTAINER-ON-FLATCAR (T/COFC) RAIL, MOTOR, OR WATER CARRIERS.

⊗ONLY MILVAN CONTAINERS WHICH HAVE BEEN MODIFIED TO INCLUDE A MECHANICAL LOAD BRACING SYSTEM THAT SATISFIES THE REQUIREMENTS OF THE BUREAU OF EXPLOSIVES PAMPHLET 6C WILL BE USED FOR THE MOVEMENT OF AMMUNITION BY T/COFC SERVICE.

### DISTRIBUTION STATEMENT A:

APPROVED FOR PUBLIC RELEASE  
DISTRIBUTION IS UNLIMITED.

## U.S. ARMY MATERIEL COMMAND DRAWING

APPROVED, U.S. ARMY JOINT MUNITIONS COMMAND  <b>RUS.ALLEN.J</b> .1230354282 <small>Digitally signed by RUS.ALLEN.J.1230354282 Date: 2018.02.28 10:11:17 -06'00'</small>		<b>CAUTION: VERIFY PRIOR TO USE AT <a href="https://mhp.redstone.army.mil">HTTPS://MHP.REDSTONE.ARMY.MIL</a> THAT THIS IS THE MOST CURRENT VERSION OF THIS DOCUMENT. THIS IS PAGE 1 OF 6.</b>							
		<b>DO NOT SCALE</b>		<b>FEBRUARY 2018</b>					
		DESIGN ENGINEER	BASIC REV.	<b>SPENCER HOVEY</b>					
APPROVED BY ORDER OF COMMANDING GENERAL, U.S. ARMY MATERIEL COMMAND  <b>SHIMP.UPTON</b> .R.1231257183 <small>Digitally signed by SHIMP.UPTON.R.1231257183 Date: 2018.03.12 10:40:05 -05'00'</small>		ENGINEERING DIVISON	<b>FIEFFER.LAUR</b> A.A.1230375727 <small>Digitally signed by FIEFFER.LAURA.A.1230375727 DN: cn=US, ou=US Government, ou=DOD, ou=PA, ou=USA, ou=FIEFFER.LAURA.A.1230375727 Date: 2018.02.14 15:11:21 -06'00'</small>		CLASS	DIVISION	DRAWING	FILE	
		TEST REPORT	TEST ENGINEER	<b>FELICIANO.AD</b> N.1259200373 <small>Digitally signed by FELICIANO.ADIN.1259200373 Date: 2018.02.27 06:32:39 -06'00'</small>		19	48	4244/100	15PM1008
U.S. ARMY DEFENSE AMMUNITION CENTER  EXPLOSIVE SAFETY DIRECTORATE			<b>THOMAS.CARL.AN</b> THONY.1104621372 <small>Digitally signed by THOMAS.CARL.ANTHONY.1104621372 Date: 2018.02.27 07:04:39 -06'00'</small>						

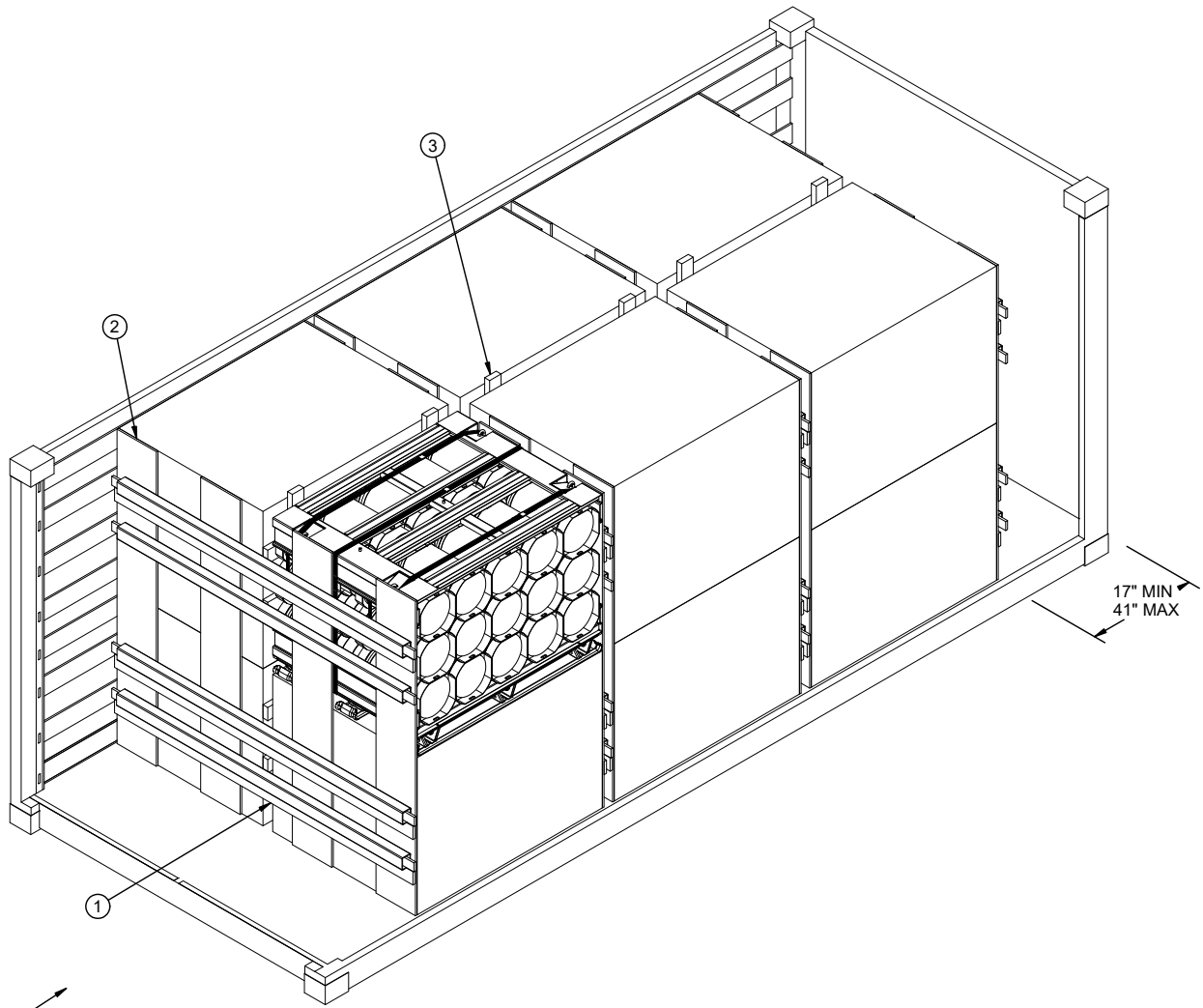

REAR OF CONTAINER

**ISOMETRIC VIEW**

**KEY NUMBERS**

- ① CROSS MEMBER (16 REQD). POSITION AS SHOWN IN THE DETAIL ABOVE AT THE 16", 28", 60", AND 72" HEIGHTS. SEE THE "FILL DETAIL" ON PAGE 6.
- ② LOAD BEARING GATE (6 REQD). SEE THE DETAIL ON PAGE 5.
- ③ CENTER FILL ASSEMBLY (3 REQD). SEE THE DETAIL ON PAGE 5.

**BILL OF MATERIAL**

LUMBER	LINEAR FEET	BOARD FEET
1" X 4"	137	46
2" X 4"	100	66
NAI LS	NO. REQD	POUNDS
6d (2")	288	1-3/4
10d (3")	48	3/4
PLYWOOD, 1/2"	166 SQ FT REQD	228.25 LBS
CROSS MEMBER	12 REQD	

**LOAD AS SHOWN**

ITEM	QUANTITY	WEIGHT (APPROX)
PALLET UNIT	12	24,936 LBS
DUNNAGE		454 LBS
CONTAINER		5,700 LBS
TOTAL WEIGHT		31,090 LBS (APPROX)

**GENERAL NOTES**

**(GENERAL NOTES CONTINUED)**

- A. THIS DOCUMENT HAS BEEN PREPARED AND ISSUED IN ACCORDANCE WITH AR 740-1 AND AUGMENTS TM 743-200-1 (CHAPTER 5).
- B. THE SPECIFIED OUTLOADING PROCEDURES ARE APPLICABLE TO LOADS OF M93 WIDE AREA MUNITION (WAM), OR M98 WAM TRAINER, PACKED IN PA160 CYLINDRICAL METAL CONTAINERS. SUBSEQUENT REFERENCE TO CONTAINER HEREIN MEANS CONTAINER WITH MUNITION ITEMS. SEE PAGE 4 AND AMC DRAWING 19-48-4231/100 FOR DETAILS OF THE CONTAINER. **CAUTION:** REGARDLESS OF THE QUANTITY OF UNITS TO BE SHIPPED, THE "MAXIMUM GROSS WEIGHT" OF THE MILVAN CONTAINER MUST NOT BE EXCEEDED.
- C. THE LOADS AS SHOWN ARE BASED ON A 20' LONG BY 8' WIDE BY 8' HIGH MILVAN CONTAINER WITH INSIDE DIMENSIONS OF 19'-4" LONG BY 92" WIDE BY 87" HIGH. THE LOADS ARE DESIGNED FOR TRAILER/CONTAINER-ON-FLATCAR (T/COFC) SHIPMENT.
- D. THE SPECIFIED OUTLOADING PROCEDURES ARE FOR CONTAINERS EQUIPPED WITH SELF-CONTAINED MECHANICAL BRACING DEVICES AS DESCRIBED IN MIL-C-52661. CROSS MEMBER ATTACHMENT FACILITIES WITHIN THESE CONTAINERS MUST PROVIDE FOR THE INSTALLATION OF LOAD BLOCKING CROSS MEMBERS AT THE HEIGHTS SPECIFIED. VOIDS LENGTHWISE WITHIN THE LOAD MUST BE HELD TO A MINIMUM. CROSS MEMBERS MUST BE PLACED AGAINST THE LADING AS TIGHTLY AS THE HOLE SPACING IN THE CROSS MEMBER ATTACHMENT FACILITY PERMITS. SEE THE "FILL DETAIL" ON PAGE 6 FOR ADDITIONAL GUIDANCE. EACH CROSS MEMBER WILL BE INSTALLED WITH THE ENDS ATTACHED AS NEARLY AS POSSIBLE IN "MATED" POSITIONS (AT EQUAL HEIGHTS, AND AT EQUAL DISTANCES FROM THE END OF THE CONTAINER). CROSS MEMBERS IN EMPTY CONTAINERS AND THOSE NOT USED IN LOADED CONTAINERS MUST BE FASTENED INTO BELT RAILS FOR SHIPMENT. COMPONENTS ASSIGNED TO EACH CONTAINER MUST REMAIN THEREWITH EVEN THOUGH UNUSED DURING SOME SHIPMENTS. THE LOAD BLOCKING COMPONENT DESIGNATED AS "CROSS MEMBER" HEREIN IS IDENTIFIED AS "BEAM ASSEMBLY" WITHIN TM 55-8115-200-23&P, DATED DECEMBER 1979. THE BEAM ASSEMBLY IS FURTHER IDENTIFIED AS NSN 8115-00-165-6623.
- E. WHEN LOADING PALLET UNITS, THEY ARE TO BE POSITIONED SO AS TO ACHIEVE A TIGHT LOAD (TIGHT AGAINST THE DUNNAGE ASSEMBLIES). THE UNBLOCKED SPACE ACROSS THE WIDTH OF A LOAD BAY IS NOT TO EXCEED 1-1/2". EXCESSIVE SLACK CAN BE ELIMINATED BY LAMINATING ADDITIONAL PIECES OF APPROPRIATE THICKNESS TO THE HORIZONTAL PIECES ON THE CENTER FILL ASSEMBLIES. NAIL EACH ADDITIONAL PIECE TO THE HORIZONTAL PIECE W/1 APPROPRIATELY SIZED NAIL EVERY 12". ADDITIONALLY, THE THICKNESS OF THE HORIZONTAL PIECES IN THE CENTER FILL ASSEMBLY MAY BE ADJUSTED, AS NECESSARY, TO FACILITATE VARIANCE IN THE PALLET UNIT SIZE.
- F. DUNNAGE LUMBER SPECIFIED IS OF NOMINAL SIZE. FOR EXAMPLE, 1" X 4" MATERIAL IS ACTUALLY 3/4" THICK BY 3-1/2" WIDE AND 2" X 6" MATERIAL IS ACTUALLY 1-1/2" THICK BY 5-1/2" WIDE.
- G. A STAGGERED NAILING PATTERN WILL BE USED WHENEVER POSSIBLE WHEN NAILS ARE DRIVEN INTO JOINTS OF DUNNAGE ASSEMBLIES OR WHEN LAMINATING DUNNAGE. ADDITIONALLY, THE NAILING PATTERN FOR AN UPPER PIECE OF LAMINATED DUNNAGE WILL BE ADJUSTED AS REQUIRED SO THAT A NAIL FOR THAT PIECE WILL NOT BE DRIVEN THROUGH ONTO OR RIGHT BESIDE A NAIL IN A LOWER PIECE.
- H. **CAUTION:** DO NOT NAIL DUNNAGE MATERIAL TO THE MILVAN WALLS OR FLOOR. ALL NAILING WILL BE WITHIN THE DUNNAGE.
- J. PORTIONS OF THE MILVAN DEPICTED WITHIN THIS DRAWING, SUCH AS ONE OF THE SIDEWALLS, HAVE NOT BEEN SHOWN IN THE LOAD VIEWS FOR CLARITY PURPOSES.

**K. MAXIMUM LOAD WEIGHT CRITERIA:**

THE MAXIMUM LOAD WEIGHTS ARE CONTROLLED BY EQUIPMENT CAPABILITY FACTORS. ALTHOUGH THE HEAVIEST MAXIMUM LOADS ARE DELINEATED IN THE LOAD VIEWS, PROVISIONS ARE INCLUDED WITHIN THIS DRAWING SO THAT THE BASIC LOADS CAN BE ADJUSTED TO SATISFY A LESSER QUANTITY OF LADING UNITS. DEPENDING ON TRANSPORTATION ROUTING, IT MAY BE NECESSARY TO REDUCE THE LOAD WEIGHT TO SATISFY "WEIGHT LAWS" OF CERTAIN STATES. ALSO, IT MAY BE NECESSARY TO REDUCE THE LOAD WEIGHT TO SATISFY OTHER WEIGHT RESTRICTIONS IMPOSED ON THE INTERMODAL CONTAINER SYSTEM.

(CONTINUED AT RIGHT)

- L. REQUIREMENTS CITED WITHIN THE ASSOCIATION OF AMERICAN RAILROADS (AAR) INTERMODAL LOADING GUIDE APPLY WHEN THE SHIPMENT MOVES BY TRAILER/CONTAINER-ON-FLATCAR (T/COFC). SPECIAL T/COFC NOTES FOLLOW:
  1. **CAUTION:** LOADED CONTAINERS MUST BE ON CHASSIS EQUIPPED WITH TWO BOGIE ASSEMBLIES WHEN BEING MOVED IN TOFC SERVICE, REGARDLESS OF THE LOAD WEIGHT WITHIN THE CONTAINER.
  2. LOAD LIMITS OF T/COFC RAIL CARS MUST NOT BE EXCEEDED, NOR WILL A CAR BE LOADED SO THAT THE TRUCK UNDER ONE END OF THE CAR CARRIES MORE THAN ONE-HALF OF THE LOAD LIMIT FOR THAT CAR.
  3. CHASSIS/CONTAINERS COUPLED INTO A 40-FOOT TRAILER CONFIGURATION MUST BE PLACED AT THE B-END OF A TOFC RAILCAR. THE REAR END OF THE 40-FOOT UNIT WILL OVERHANG THE END OF THE CAR IF IT IS PLACED AT THE A-END. TWENTY-FOOT AND 40-FOOT UNITS CAN BE LOADED ON THE SAME CAR.
- M. TO MAKE LOADING EASIER, TO HELP ACHIEVE A TIGHT LOAD ACROSS A CONTAINER, AND TO PREVENT UNACCEPTABLE DAMAGE TO LADING UNITS WHEN LOADING A MILVAN, A SLIP-SHEET CAN BE USED EFFECTIVELY AS A "SHOEHORN" TYPE DEVICE. THE SLIP-SHEET WILL PROVIDE A SMOOTH SURFACE THAT WILL PREVENT UNIT STRAPS AND/OR CONTAINERS FROM INTERLOCKING OR CATCHING ON OTHER PROJECTIONS WHEN LATERALLY ADJACENT LADING UNITS ARE BEING LOADED. A SLIP-SHEET WILL BE USED AFTER ONE-HALF OF A STACK IS LOADED WITH ONE OF ITS SIDES IN TIGHT CONTACT AT ONE SIDE OF THE MILVAN. THE SLIP-SHEET IS TO BE PLACED AGAINST THE OTHER SIDE OF THE HALF-STACK BEFORE THE LAST HALF OF THE STACK IS LOADED. AFTER A STACK IS COMPLETED, THE SLIP-SHEET IS TO BE REMOVED FOR SUBSEQUENT USE WITH THE NEXT STACK. A SLIP-SHEET OF SUITABLE SIZE CAN BE MADE FROM A SHEET OF 1/8" TEMPERED HARDBOARD (MASONITE) OR FROM A SHEET OF ANY OTHER MATERIAL THAT WILL SATISFY THE REQUIREMENTS.
- N. WHETHER A CONTAINER IS FULL OR IS LOADED WITH A REDUCED QUANTITY OF LADING UNITS, THE LENGTHWISE CENTER OF GRAVITY OF THE LOAD MUST BE WITHIN 12", IN EITHER DIRECTION, OF THE MID-POINT OF THE CONTAINER.
- O. THE QUANTITY OF CONTAINERS SHOWN IN THE LOAD ON PAGE 2 MAY BE REDUCED FOR SHIPMENT, IF DESIRED. SEE THE LESS-THAN- FULL LOAD DETAIL ON PAGE 6.
  1. IF A LOAD IS REDUCED BY ONLY A SMALL AMOUNT (ONE, TWO OR THREE LADING UNITS), LADING UNITS NORMALLY MAY BE ELIMINATED FROM THE REAR OF THE LOAD.
  2. IF A LOAD IS REDUCED BY A LARGE AMOUNT (MORE THAN THREE LADING UNITS), LADING UNITS SHOULD BE ELIMINATED AS REQUIRED AND THE TOTAL LOAD SHIFTED FORE OR AFT, AS NECESSARY, TO ACHIEVE A SYMMETRICAL WEIGHT DISTRIBUTION. THE DEPICTED PROCEDURES WILL BE FOLLOWED AS CLOSELY AS POSSIBLE, MAKING ONLY THOSE ADJUSTMENTS TO THE DUNNAGE WHICH ARE REQUIRED TO ACCOMMODATE THE NUMBER OF UNITS TO BE SHIPPED.
- P. ANTI-CHAFING MATERIAL MAY BE INSTALLED AT POINTS OF CONTACT BETWEEN PALLET UNITS AND THE MILVAN IF DESIRED, TO PREVENT CHAFING DAMAGE TO CONTAINER PAINT AND MARKINGS.
- Q. CONVERSION TO METRIC EQUIVALENTS: DIMENSIONS WITHIN THIS DOCUMENT ARE EXPRESSED IN INCHES, AND WEIGHTS ARE EXPRESSED IN POUNDS. WHEN NECESSARY, THE METRIC EQUIVALENTS MAY BE COMPUTED ON THE BASIS OF ONE INCH EQUALS 25.4MM AND ONE POUND EQUALS 0.454 KG.

**MATERIAL SPECIFICATIONS**

- LUMBER** - - - - - : SEE TM 743-200-1 (DUNNAGE LUMBER) AND VOLUNTARY PRODUCT STANDARD PS 20.
- NAILS** - - - - - : ASTM F1667; COMMON STEEL NAIL (NLCMS OR NLCMMS).
- PLYWOOD** - - - - - : COMMERCIAL ITEM DESCRIPTION A-A-55057, INDUSTRIAL PLYWOOD, INTERIOR WITH EXTERIOR GLUE, GRADE C-D. IF SPECIFIED GRADE IS NOT AVAILABLE, A BETTER INTERIOR OR AN EXTERIOR GRADE MAY BE SUBSTITUTED.
- ANTI-CHAFING MATERIAL** - - - - - : MIL-PRF-121 (OR EQUAL); NEUTRAL BARRIER MATERIAL.
- WIRE, CARBON STEEL** - - - : ASTM A853; ANNEALED AT FINISH, BLACK OXIDE FINISH, 0.0800" DIA, GRADE 1006 OR BETTER.

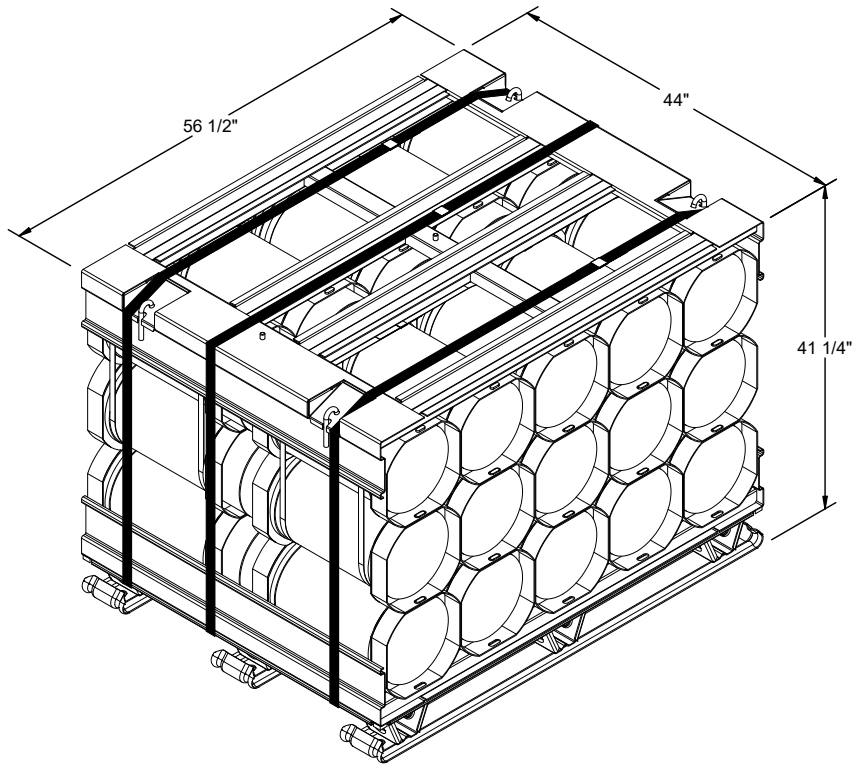

**PALLET UNIT DATA**

GROSS WEIGHT - - - - - 2,078 LBS (APPROX)  
 CUBE - - - - - 59.7 CU FT (APPROX)

RETAINER PIECE, 2" X 4" BY CUT-TO-FIT  
 IN LENGTH (2 REQD). NAIL TO THE STRUTS  
 W/1-10d NAIL AT EACH JOINT AND TO THE  
 BUFFER PIECE W/4-10d NAILS.

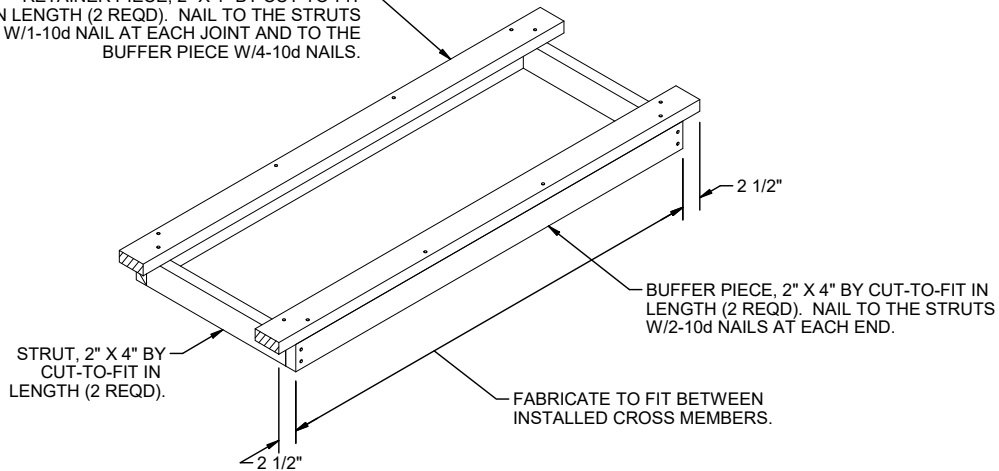

**SPACER ASSEMBLY**

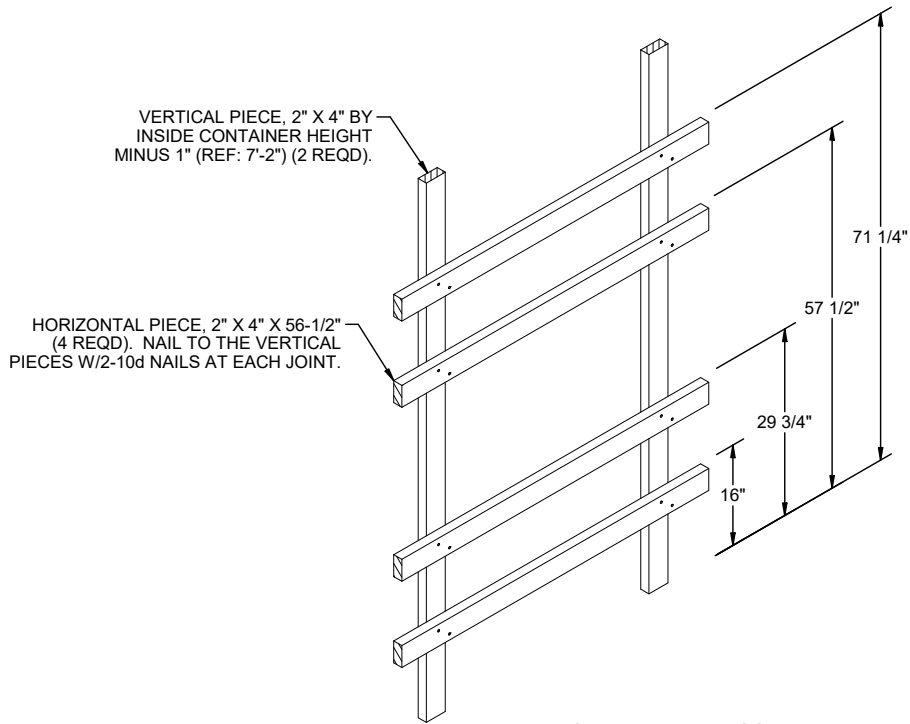

**CENTER FILL ASSEMBLY**

FOR A ONE HIGH TWO WIDE LOAD, ELIMINATE THE TOP TWO HORIZONTAL PIECES. FOR THE REDUCED LOAD DEPICTED ON PAGE 6, MODIFY ONE CENTER FILL ASSEMBLY BY ELIMINATING THE TOP TWO HORIZONTAL PIECES AND REDUCING THE HEIGHT OF THE VERTICAL PIECES TO 41-1/2".

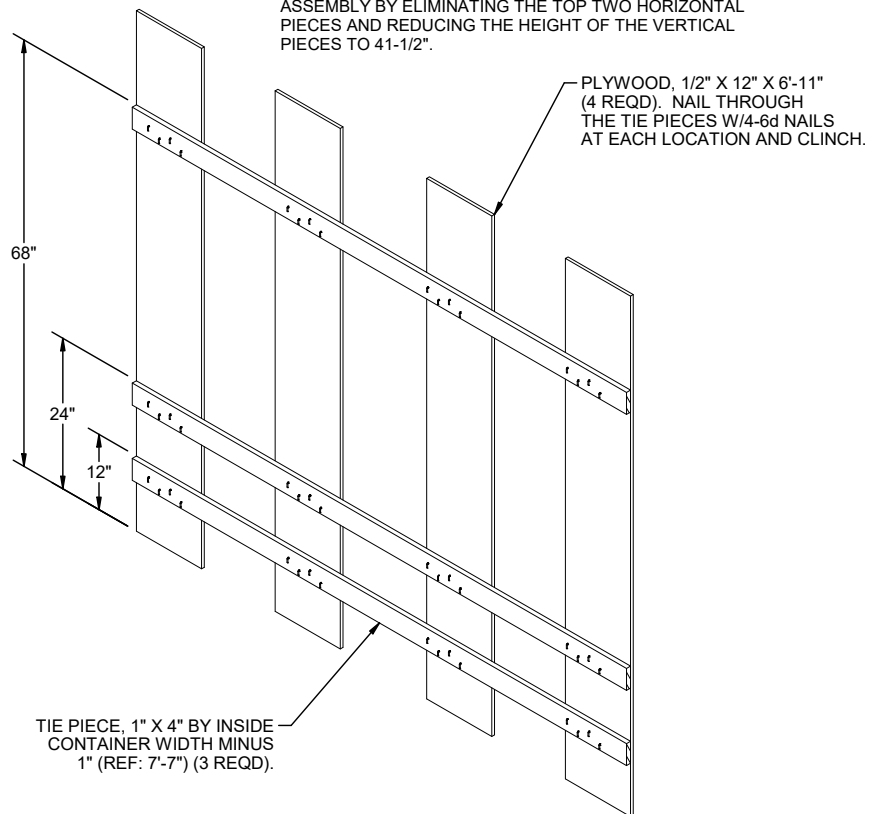

**LOAD BEARING GATE**

FOR A ONE HIGH TWO WIDE LOAD, ELIMINATE THE TOP TIE PIECE, AND SHORTEN THE PLYWOOD TO 41-1/2". FOR THE REDUCED LOAD DEPICTED ON PAGE 6, MODIFY TWO LOAD BEARING GATES BY REDUCING THE TWO OUTSIDE PLYWOOD PIECES TO 41-1/2", SHORTENING THE TOP TIE PIECE TO 40", AND INSTALLING THE TOP TIE PIECE ACROSS THE MIDDLE TWO PLYWOOD PIECES.

TIE WIRE, .0800" DIA BY 18" LONG (4 REQD PER SPACER ASSEMBLY). INSTALL TO FORM A COMPLETE LOOP AROUND THE SPACER ASSEMBLY AND THE CROSS MEMBER. BRING ENDS TOGETHER AND TWIST TAUT. INSTALL ONE AT EACH CORNER OF THE ASSEMBLY.

REAR OF CONTAINER

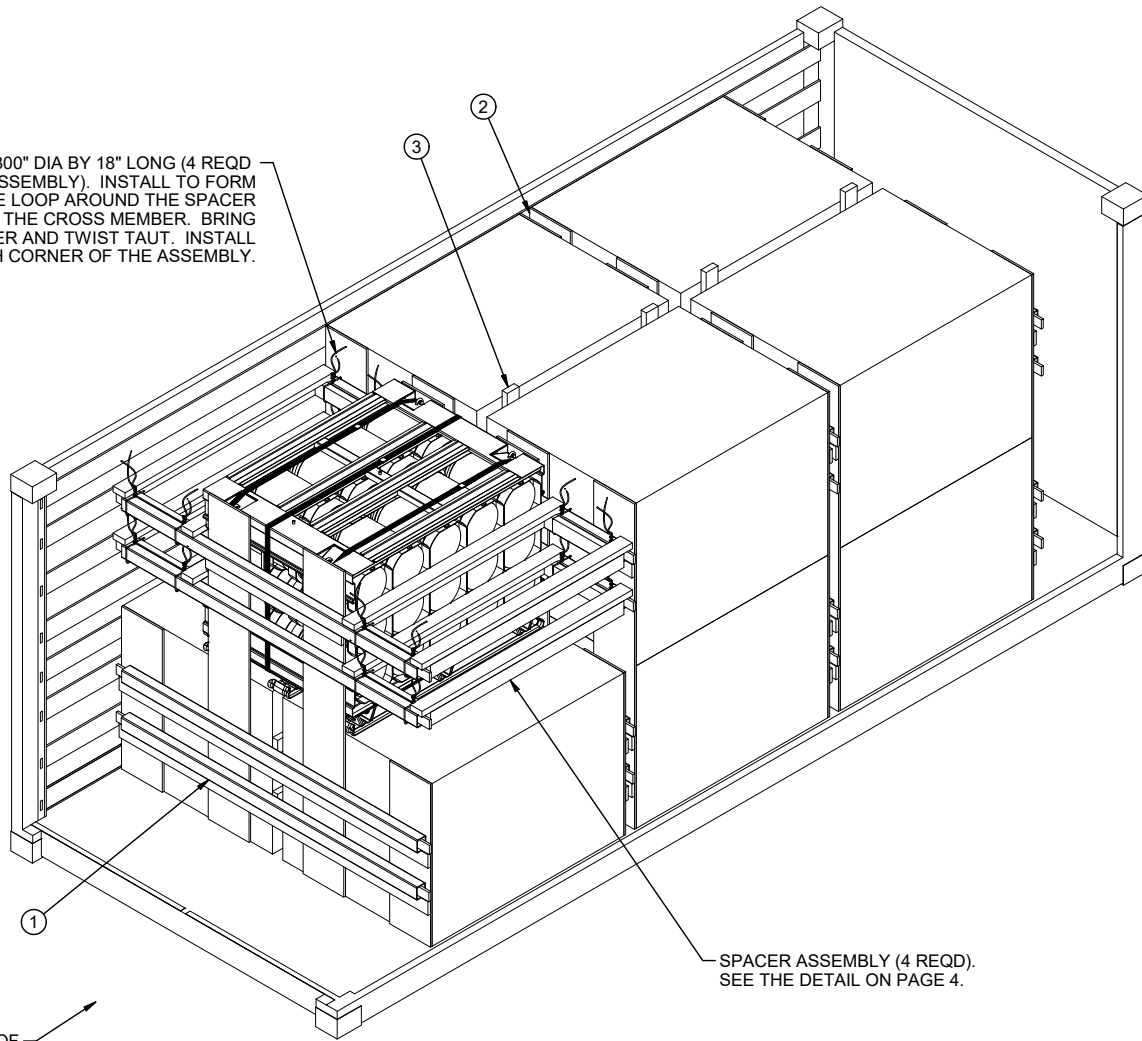

**LESS-THAN-FULL-LOADPROCEDURE**

KEY NUMBERS REFER TO KEY NUMBERS ON PAGE 2. NOTE THAT TWO BEARING GATES HAVE BEEN MODIFIED AS DESCRIBED ON PAGE 5. SEE GENERAL NOTES "N" AND "O" ON PAGE 3.

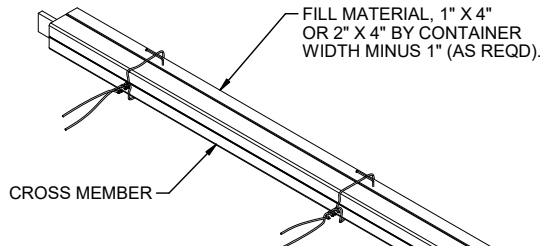

TIE WIRE, 0.0800" DIA WIRE 18" LONG (3 REQD PER CROSSMEMBER). INSTALL TO FORM A COMPLETE LOOP AROUND FILL MATERIAL AND CROSS MEMBER, BRING ENDS TOGETHER AND TWIST TAUT. SECURE TO FILL MATERIAL WITH A PARTIALLY DRIVEN 10d NAIL BENT OVER THE WIRE, OR WITH A STRAP STAPLE.

**FILL DETAIL**

THIS DETAIL DEPICTS THE METHOD OF POSITIONING FILL MATERIAL BETWEEN CROSS MEMBER AND LADING, WHEN VOID BETWEEN THE TWO IS GREATER THAN 1".