

LOADING AND BRACING (TL & LTL) IN VAN TRAILERS OF 2.75 INCH HYDRA ROCKETS PACKED IN CYLINDRICAL METAL CONTAINERS



PA151 SERIES CONTAINERS

INDEX

ITEM	PAGE(S)
GENERAL NOTES AND MATERIAL SPECIFICATIONS	2, 3
PALLET UNIT DETAIL	3
21-UNIT LOAD IN A 40'-0" LONG BY 7'-8" WIDE TRAILER	4, 5
21-UNIT LOAD IN A 45'-0" LONG BY 8'-2" WIDE TRAILER	6, 7
17-UNIT LOAD IN A 42'-0" LONG BY 7'-8" WIDE TRAILER	8, 9
18-UNIT COMBINATION LOAD IN A 40'-0" LONG BY 8'-2" WIDE TRAILER	10, 11
16-UNIT COMBINATION LOAD IN A 40'-0" LONG BY 7'-8" WIDE TRAILER	12, 13
15-UNIT (1-WIDE) LOAD IN A 40'-0" LONG TRAILER	14, 15
TYPICAL LTL (5-UNIT LOAD)	16, 17
TYPICAL LTL (1-UNIT LOAD)	18, 19
DETAILS	20-24
PROCEDURES FOR SHIPMENT OF LEFTOVER CONTAINERS	25
PROCEDURES FOR SHIPMENT OF PARITAL PALLET UNITS	26
PROCEDURES FOR VAN TRAILERS EQUIPPED WITH LARGE-ANGLED FRONT CORNERS	27

● CAUTION: THE PROCEDURES SHOWN HEREIN ARE ONLY APPLICABLE FOR HIGHWAY MOVEMENTS; NOT FOR TRAILER-ON-FLATCAR (TOFC) MOVEMENTS.

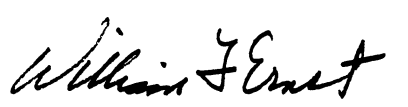
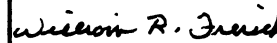
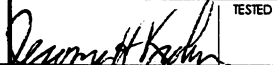
U.S. ARMY MATERIEL COMMAND DRAWING

APPROVED, U.S. ARMY INDUSTRIAL OPERATIONS COMMAND 	ENGINEER	BASIC	Laura Fieffer	DO NOT SCALE			
		REV.		WEBSITE: HTTP://WWW.DAC.ARMY.MIL			
	TECHNICIAN	BASIC		MARCH 1997			
		REV.					
DRAFTSMAN	BASIC						
		REV.					
APPROVED BY ORDER OF COMMANDING GENERAL, U.S. ARMY MATERIEL COMMAND 	TRANSPORTATION ENGINEERING DIVISION						
	VALIDATION ENGINEERING DIVISION		 TESTED	CLASS	DIVISION	DRAWING	FILE
	LOGISTICS ENGINEERING OFFICE			19	48	4243/ 61	11PM1004

PROJECT CA 255/61-88

GENERAL NOTES

- A. THIS DOCUMENT HAS BEEN PREPARED AND ISSUED IN ACCORDANCE WITH AR 740-1 AND AUGMENTS TM 743-200-1 (CHAPTER 5).
- B. THE OUTLOADING PROCEDURES SPECIFIED IN THIS DRAWING ARE APPLICABLE TO LOADS OF 2.75 INCH HYDRA ROCKETS PACKED FOUR PER PA151 CYLINDRICAL METAL CONTAINER. FOR DETAIL OF THE PALLET UNIT, SEE U.S. ARMY MATERIEL COMMAND DRAWING 19-48-4231/61-20PM1006 AND PAGE 3.
- PALLET DIMENSIONS: 29-5/16" LONG X 70-3/4" WIDE X 43" HIGH
GROSS WEIGHT: 2,029 POUNDS (APPROX)
CUBE: 51.6 CUBIC FEET (APPROX)
- C. THE OUTLOADING PROCEDURES DEPICTED WITHIN THIS DOCUMENT ARE APPLICABLE FOR SHIPMENTS IN CONVENTIONAL TYPE VAN TRAILERS AND APPLY TO TRAILERS HAVING WOOD, OR WOOD AND METAL, OR ALL METAL FLOORS. REGARDLESS OF THE DIMENSIONS OF THE VAN TRAILERS SHOWN, THE PROCEDURES ARE ALSO APPLICABLE FOR TRAILERS WHICH ARE 89" THRU 99" IN WIDTH AND FOR TRAILERS OF OTHER LENGTHS FROM THE SHORTEST TO THE LONGEST AVAILABLE (REF: 24' TO 53'), AND FOR STRAIGHT TRUCK VANS. THE SPECIFIED BRACING IS ADEQUATE FOR LOADS WEIGHING UP TO AND INCLUDING THE MAXIMUM WEIGHTS PERMITTED BY LAW.
- D. SELECTION OF A VEHICLE TO BE USED TO TRANSPORT THE DESIGNATED ITEM MUST COMPLY WITH AR 55-355, CHAPTER 29, FOR EXPLOSIVES AND OTHER DANGEROUS ARTICLES, IN FULL.
- E. THE GROSS WEIGHT AND AXLE DISTRIBUTION OF WEIGHT FOR A LOAD WILL BE THE RESPONSIBILITY OF THE CARRIER. THE CARRIER WILL ADVISE THE SHIPPER OF THE APPLICABLE LOADING REQUIREMENTS, AND THE SHIPPER WILL LOAD ACCORDINGLY. THE TOTAL WEIGHT OF THE LADING, OF THE DUNNAGE, OF THE TRACTOR, AND OF THE SEMITRAILER CARRYING THE LADING MUST NOT EXCEED THE MAXIMUM GROSS WEIGHT ALLOWED FOR THE STATE OR STATES THRU WHICH THE LOAD IS TO BE TRANSPORTED BY MOTOR CARRIER. LIKEWISE, THE GROSS WEIGHT ON A SINGLE OR TANDEM AXLE MUST NOT EXCEED THE MAXIMUM ALLOWABLE WEIGHT. IF THERE IS ANY DOUBT AS TO WHETHER THE TOTAL GROSS WEIGHT OR AXLE WEIGHT EXCEEDS THE MAXIMUM ALLOWED, WEIGHT SHOULD BE VERIFIED BY ACTUALLY WEIGHING THE LOADED VEHICLE.
- F. NOTICE: A SHIPMENT WILL BE POSITIONED IN THE TRAILER CONSISTENT WITH STATE WEIGHT LAWS. THE NUMBER OF LADING UNITS MAY BE ADJUSTED TO FIT THE SIZE OF THE TRAILER TO BE LOADED OR THE QUANTITY TO BE SHIPPED. COMBINATIONS OF THE OUTLOADING PROCEDURES SPECIFIED MAY BE USED, HOWEVER, THE APPROVED METHODS SHOWN MUST BE FOLLOWED AS CLOSELY AS POSSIBLE FOR BLOCKING, BRACING, AND STAYING OF THE DESIGNATED ITEMS.
- G. THE "LOAD AS SHOWN" FOR MOST OF THE FULL LOADS DEPICTED HEREIN IS BASED ON AN APPROXIMATE LADING WEIGHT OF 43,000 POUNDS. THE SPECIFIED BLOCKING AND BRACING FOR THE FULL LOADS IS ADEQUATE FOR THE RETENTION OF LOADS, UP TO 45,000 POUNDS, IF IT IS DESIRED TO INCREASE THE LADING WEIGHT.
- H. OTHER TYPES OF LADING ITEMS MAY BE LOADED INTO TRAILERS WHICH ARE PARTIALLY LOADED WITH PALLET UNITS OF ROCKETS, PROVIDING THE TOTAL LOAD IS COMPATIBLE, EXISTING DIRECTIVES ARE NOT VIOLATED, AND THE OTHER LADING ITEMS ARE BLOCKED AND BRACED TO EQUAL THE BLOCKING AND BRACING CRITERIA SPECIFIED HEREIN.

(CONTINUED AT RIGHT)

MATERIAL SPECIFICATIONS

LUMBER: SEE TM 743-200-1 (DUNNAGE LUMBER) AND FED SPEC MM-L-751.

NAILS: FED SPEC FF-N-105; COMMON.

STRAPPING, STEEL: ASTM D3953; FLAT STRAPPING, TYPE 1, HEAVY DUTY, FINISH A, B (GRADE 2), OR C.

SEAL, STRAP: ASTM D3953; CLASS H, FINISH A, B (GRADE 2), OR C, DOUBLE NOTCH TYPE, STYLE I, II, OR IV.

(GENERAL NOTES CONTINUED)

- J. SOME LOADS ARE SHOWN IN TRAILERS HAVING ROUNDED CORNERS AT THE FORWARD END. IF THE CONVENTIONAL VAN TRAILER BEING USED IS EQUIPPED WITH A SQUARE FRONT OR WITH AN INSTALLED BULKHEAD, OMIT THE FORWARD BLOCKING ASSEMBLY, PIECE MARKED ①, AND POSITION THE PALLET UNITS DIRECTLY AGAINST THE FORWARD PORTION OF THE TRAILER.
- K. WHEN STEEL STRAPPING IS SEALED AT AN END-OVER-END LAP JOINT, A MINIMUM OF ONE SEAL WITH TWO PAIR OF NOTCHES WILL BE USED TO SEAL THE JOINT WHEN A NOTCH-TYPE SEALER IS BEING USED. A MINIMUM OF TWO SEALS, BUTTED TOGETHER WITH TWO PAIR OF CRIMPS PER SEAL WILL BE USED TO SEAL THE JOINT WHEN A CRIMP-TYPE SEALER IS BEING USED. REFER TO THE "STRAP JOINT A" AND "STRAP JOINT B" DETAILS ON PAGE 24 FOR GUIDANCE.
- L. DUNNAGE LUMBER SPECIFIED THROUGHOUT THIS PROCEDURAL DRAWING IS OF NOMINAL SIZE. FOR EXAMPLE, 2" X 4" MATERIAL IS ACTUALLY 1-1/2" THICK BY 3-1/2" WIDE AND 2" X 6" MATERIAL IS ACTUALLY 1-1/2" THICK BY 5-1/2" WIDE.
- M. NOTICE: A STAGGERED NAILING PATTERN WILL BE USED WHEREVER POSSIBLE WHEN NAILS ARE DRIVEN INTO JOINTS OF DUNNAGE ASSEMBLIES. ALSO, A STAGGERED NAILING PATTERN WILL BE USED WHEN DUNNAGE IS NAILED TO THE FLOOR OF THE TRANSPORTING VEHICLE, OR WHEN LAMINATING DUNNAGE. THE NAILING PATTERN WILL BE ADJUSTED AS REQUIRED SO THAT A NAIL DOES NOT PENETRATE INTO OR NEAR A CRACK BETWEEN FLOOR BOARDS. ADDITIONALLY, THE NAILING PATTERN FOR AN UPPER PIECE OF LAMINATED DUNNAGE WILL BE ADJUSTED AS REQUIRED SO THAT A NAIL FOR THAT PIECE WILL NOT BE DRIVEN THROUGH THE PIECE ONTO OR RIGHT BESIDE A NAIL IN A LOWER PIECE.
- N. POWER DRIVEN STAPLES MAY BE USED AS ALTERNATIVE FASTENERS FOR NAILS WHEN CONSTRUCTING DUNNAGE ASSEMBLIES WHICH ARE TO BE USED IN THE DELINEATED TRAILER LOADS SHOWN THROUGHOUT THIS DRAWING. THE STAPLES TO BE USED MUST BE EQUAL IN LENGTH TO THE SPECIFIED NAIL SIZE AND MUST BE SUBSTITUTED ON A ONE STAPLE FOR ONE NAIL BASIS. STAPLES WHICH ARE 2-1/2" OR LESS IN LENGTH SHOULD BE IN ACCORDANCE WITH FEDERAL SPECIFICATION FF-N-105 AS NEARLY AS PRACTICABLE. STAPLES WHICH ARE LONGER THAN 2-1/2" WILL BE A COMMERCIAL GRADE, OF A QUALITY EQUIVALENT TO THOSE MANUFACTURED BY SENCO PRODUCTS INCORPORATED. NOTE: STAPLES WILL NOT BE SUBSTITUTED FOR NAILS IN ANY LOAD RESTRAINING FLOOR DUNNAGE APPLICATION.
- O. PORTIONS OF THE TRAILERS, SUCH AS SIDEWALLS, ENDWALLS, AND ROOFS, HAVE NOT BEEN SHOWN IN THE LOAD VIEWS FOR CLARITY PURPOSES.
- P. THE UNBLOCKED SPACE ACROSS THE WIDTH OF A LOAD BAY IS NOT TO EXCEED 6". EXCESSIVE SLACK CAN BE ELIMINATED FROM A LOAD BY LAMINATING ADDITIONAL PIECES OF APPROPRIATE THICKNESS TO THE ANTI-SWAY BRACES. NAIL EACH ADDITIONAL PIECE TO THE BUFFER PIECE W/1 APPROPRIATELY SIZED NAIL EVERY 12". ADDITIONALLY, THE THICKNESS AND QUANTITY OF THE LUMBER USED IN THESE ASSEMBLIES MAY BE ADJUSTED AS REQUIRED TO FACILITATE VARIANCE IN THE SIZE OF THE PALLET UNIT.
- Q. IF THE SPACE AT THE REAR OF THE LOAD, BETWEEN THE PALLET UNITS AND THE REAR DOOR MEASURES 1-1/2" OR LESS REAR BLOCKING IS NOT REQUIRED. IF THE SPACE AT THE REAR OF THE LOAD IS GREATER THAN 1-1/2" BUT LESS THE 9". USE THE "REAR BLOCKING ASSEMBLY B" AS DEPICTED ON PAGE 21. IF THE VOID AT THE REAR OF THE LOAD IS 9" OR GREATER, USE THE "REAR BLOCKING ASSEMBLY A", AS SHOWN ON PAGE 21. NOTE: REAR BLOCKING ASSEMBLIES MAY BE REPLACED WITH NAILED HEADERS AT THE REAR OF THE LOAD, PROVIDED THE TRAILER IS CONFIGURED SUCH AS TO ALLOW NAILING IN THE AREA IN QUESTION. REFER TO PIECE MARKED ③ ON PAGE 10 AND THE HEADER NAILING CHARTS ON PAGE 7 FOR GUIDANCE. CAUTION: THE NAILED HEADER METHOD IS REQUIRED WHEN LOADING VAN TRAILERS EQUIPPED WITH ROLL-UP TYPE DOORS.
- R. CAUTION: WHEN POWER OR PNEUMATIC NAILERS ARE BEING USED IN THE APPLICATION OF NAILED FLOORLINE BLOCKING OR BRACING, PALLET UNITS BEING LOADED INTO THE CONVEYANCE MUST BE POSITIONED TO ALLOW A CLEAR PATH OF EXIT FOR THE OPERATOR AT ALL TIMES, SHOULD AN EMERGENCY EXIT BECOME NECESSARY.

(CONTINUED ON PAGE 3)

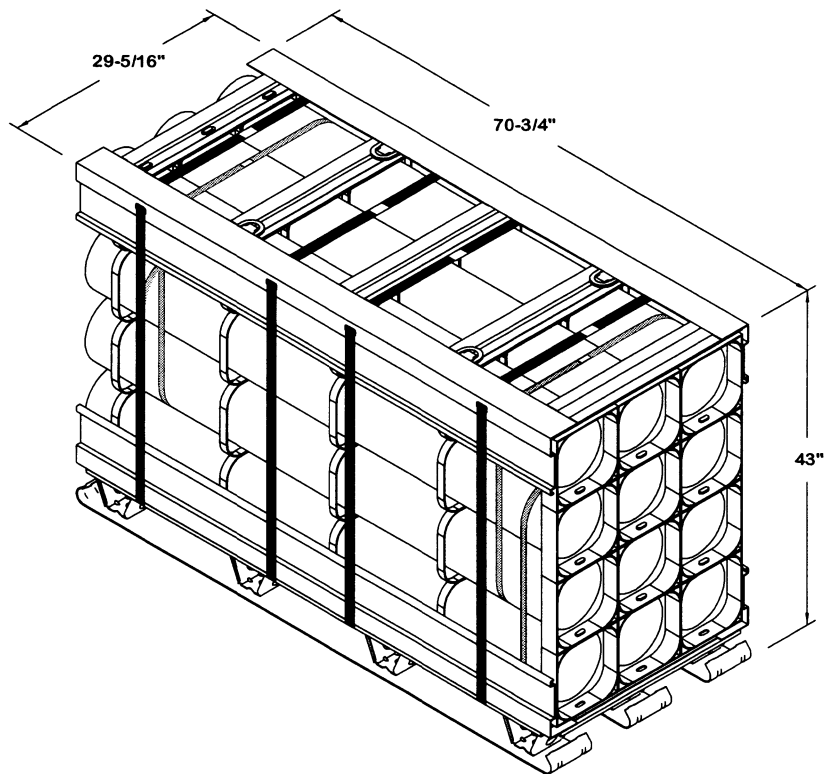

PALLET UNIT DETAIL

GROSS WEIGHT ----- 2,029 LBS (APPROX)
CUBE ----- 51.6 CUBIC FEET (APPROX)

(GENERAL NOTES CONTINUED FROM PAGE 2)

- S. PALLET UNITS WHICH DO NOT CONTAIN A FULL QUANTITY OF ITEMS CAN BE TRANSPORTED. SEE THE "SHIPMENT OF A PARTIAL PALLET UNIT" DETAILS ON PAGE 26. FOR "SHIPMENT OF LEFTOVER CONTAINERS" SEE THE DETAILS ON PAGE 25.
- T. THESE PROCEDURES CAN ALSO BE UTILIZED FOR THE SHIPMENT OF PALLET UNITS OF PA151 CONTAINERS WHEN THEY ARE LOADED WITH AN ITEM OTHER THAN THE SPECIFIED ROCKET, OR WHEN THEY ARE EMPTY.
- U. CONVERSION TO METRIC EQUIVALENTS: DIMENSIONS WITHIN THIS DOCUMENT ARE EXPRESSED IN INCHES, AND WEIGHTS ARE EXPRESSED IN POUNDS. WHEN NECESSARY, THE METRIC EQUIVALENTS MAY BE COMPUTED ON THE BASIS OF ONE INCH EQUALS 25.4MM AND ONE POUND EQUALS 0.454 KG.

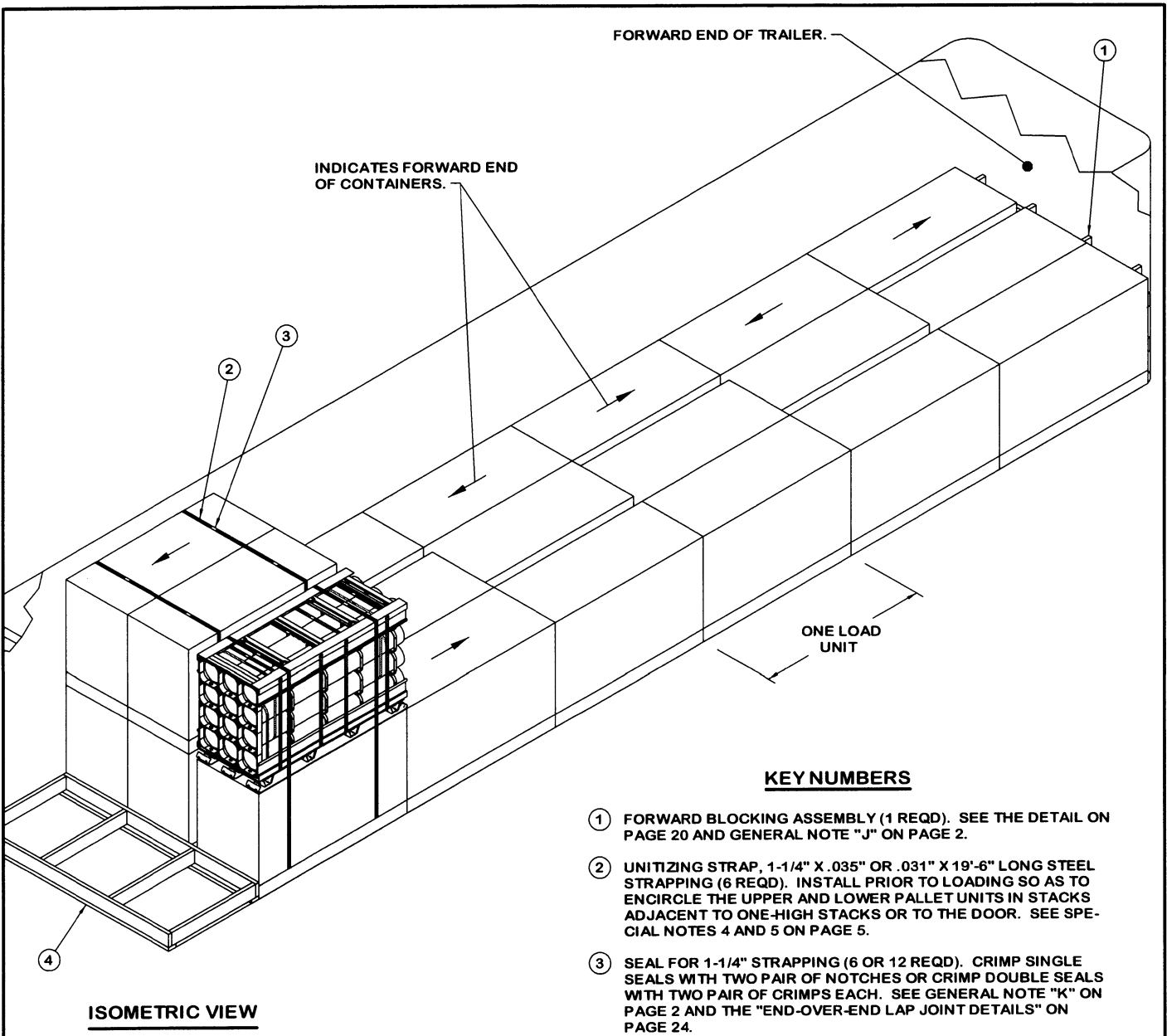

KEY NUMBERS

- ① FORWARD BLOCKING ASSEMBLY (1 REQD). SEE THE DETAIL ON PAGE 20 AND GENERAL NOTE "J" ON PAGE 2.
- ② UNITIZING STRAP, 1-1/4" X .035" OR .031" X 19'-6" LONG STEEL STRAPPING (6 REQD). INSTALL PRIOR TO LOADING SO AS TO ENIRCLE THE UPPER AND LOWER PALLET UNITS IN STACKS ADJACENT TO ONE-HIGH STACKS OR TO THE DOOR. SEE SPECIAL NOTES 4 AND 5 ON PAGE 5.
- ③ SEAL FOR 1-1/4" STRAPPING (6 OR 12 REQD). CRIMP SINGLE SEALS WITH TWO PAIR OF NOTCHES OR CRIMP DOUBLE SEALS WITH TWO PAIR OF CRIMPS EACH. SEE GENERAL NOTE "K" ON PAGE 2 AND THE "END-OVER-END LAP JOINT DETAILS" ON PAGE 24.
- ④ REAR BLOCKING ASSEMBLY A (1 REQD). SEE THE DETAIL ON PAGE 21 AND SPECIAL NOTE 3 ON PAGE 5.

SPECIAL NOTES:

1. A 40'-0" LONG BY 7'-8" WIDE (INSIDE DIMENSION) CONVENTIONAL VAN TRAILER IS SHOWN. TRAILERS OF OTHER DIMENSIONS CAN BE USED.
2. ANTI-SWAY BRACES ARE REQUIRED WHEN THE SPACE BETWEEN LATERALLY ADJACENT UNITS EXCEEDS 6", AS MEASURED FROM PALLET ADAPTER TO PALLET ADAPTER.
3. IF THE SPACE AT THE REAR OF THE LOAD BETWEEN THE PALLET UNITS AND THE REAR DOOR IS 9" OR GREATER, USE THE "REAR BLOCKING ASSEMBLY A" AS SHOWN. IF THE SPACE AT THE REAR OF THE LOAD IS GREATER THAN 1-1/2" BUT LESS THAN 9", USE THE "REAR BLOCKING ASSEMBLY B" AS DETAILED ON PAGE 21. IF THE SPACE AT THE REAR OF THE LOAD IS 1-1/2" OR LESS, REAR BLOCKING IS NOT REQUIRED. NOTE: REAR BLOCKING ASSEMBLIES MAY BE REPLACED WITH NAILED HEADERS AT THE REAR OF THE LOAD, PROVIDED THE TRAILER IS CONFIGURED SUCH AS TO ALLOW NAILING IN THE AREA IN QUESTION. REFER TO PIECE MARKED ③ ON PAGE 10 AND THE HEADER NAILING CHARTS ON PAGE 7 FOR GUIDANCE.
4. UNITIZING STRAPS, PIECE MARKED ②, MUST BE APPLIED AROUND THE TWO-HIGH STACKS WHICH ARE IMMEDIATELY ADJACENT EITHER LATERALLY OR LONGITUDINALLY TO THE ONE-HIGH UNITS. THE UNITIZING STRAPS MUST BE INSTALLED PRIOR TO FINAL POSITIONING OF THE STACK.
5. IF A STACK AT THE REAR OF THE LOAD IS MORE THAN ONE UNIT HIGH, AS IN THE DEPICTED LOAD, UNITIZING STRAPS, PIECE MARKED ②, MUST BE INSTALLED AROUND EACH OF THE REARMOST STACKS IN EACH APPLICABLE ROW.
6. ALTERNATE THE POSITION OF THE LATERAL VOID IN THE LOAD TO ENSURE A UNIFORM LOAD, AS DEPICTED IN THE LOAD ON PAGE 4.
7. THE DEPICTED LOAD CAN BE ADJUSTED TO SUIT THE QUANTITY TO BE SHIPPED, OR TO SUIT THE WEIGHT OF THE UNIT BEING LOADED. A 2-TIER LOAD CAN BE REDUCED BY A MULTIPLE OF SIX UNITS BY OMITTING ONE OR MORE FULL LOAD UNITS FROM THE LOAD; OR, THE ENTIRE TOP TIER CAN BE LEFT OFF; OR, ONE OR MORE UNITS CAN BE ADDED TO OR OMITTED FROM THE TOP TIER.
8. LEFTOVER CONTAINERS IN AN AMOUNT NOT TO EXCEED TWO CONTAINERS MAY BE SECURED TO THE TOP OF A FULL PALLET UNIT FOR SHIPMENT. REFER TO THE "PROCEDURES FOR SHIPMENT OF LEFTOVER CONTAINERS" ON PAGE 25 FOR GUIDANCE.
9. REFER TO PAGE 26 FOR GUIDANCE IN THE SHIPMENT OF PARTIAL PALLET UNITS.

BILL OF MATERIAL		
LUMBER	LINEAR FEET	BOARD FEET
2" X 4"	44	30
2" X 6"	85	85
NAILS	NO. REQD	POUNDS
10d (3")	102	1-3/4
STEEL STRAPPING, 1-1/4" ---- 117' REQD ----- 16.72 LBS		
SEAL FOR 1-1/4" STRAPPING --- 12 REQD ----- 0.55 LBS		

LOAD AS SHOWN

<u>ITEM</u>	<u>QUANTITY</u>	<u>WEIGHT (APPROX)</u>
PALLET UNIT -----	21 -----	42,609 LBS
DUNNAGE -----		250 LBS
TOTAL WEIGHT -----		42,859 LBS (APPROX)

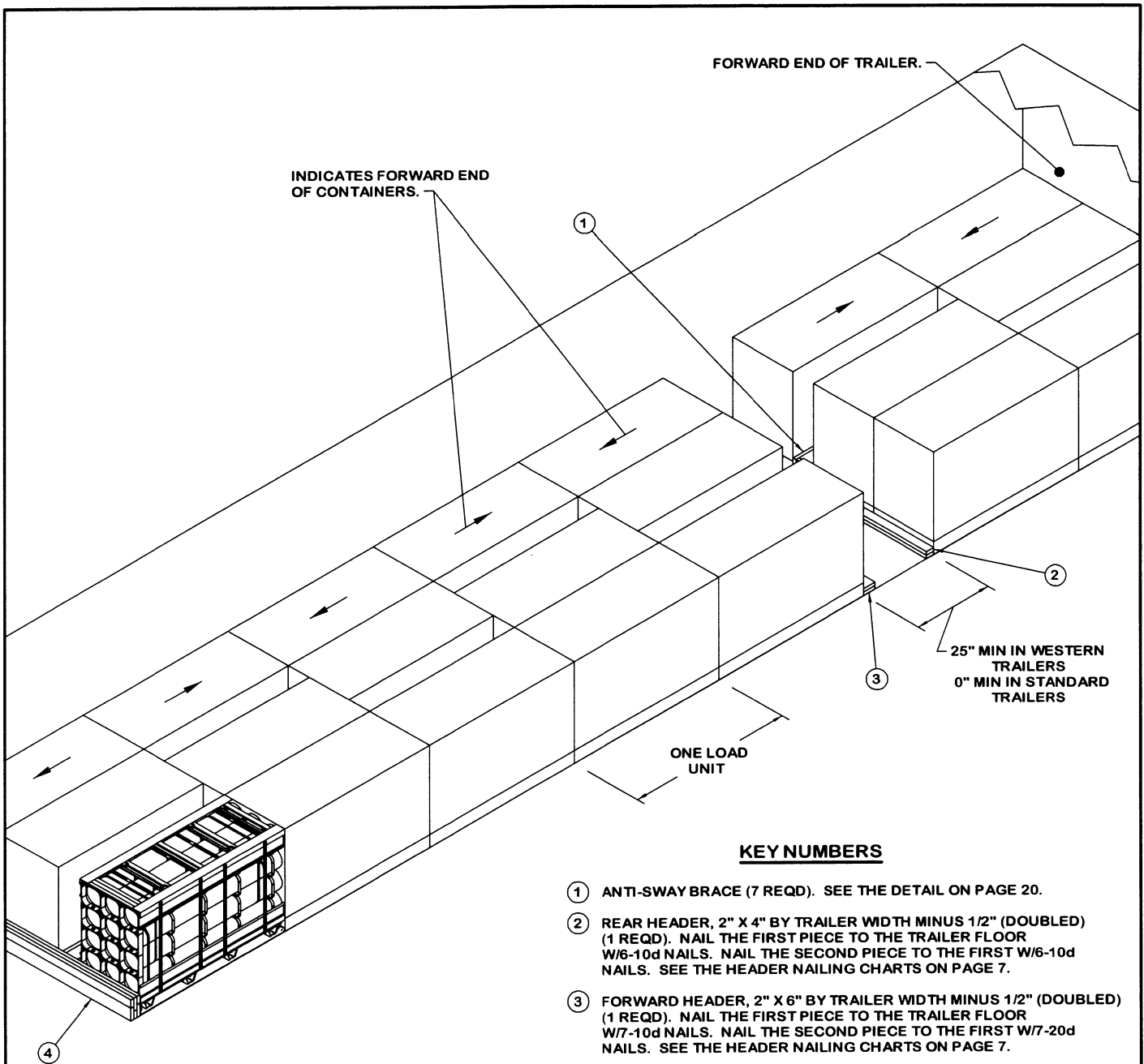

ISOMETRIC VIEW

KEY NUMBERS

- ① ANTI-SWAY BRACE (7 REQD). SEE THE DETAIL ON PAGE 20.
- ② REAR HEADER, 2" X 4" BY TRAILER WIDTH MINUS 1/2" (DOUBLED) (1 REQD). NAIL THE FIRST PIECE TO THE TRAILER FLOOR W/6-10d NAILS. NAIL THE SECOND PIECE TO THE FIRST W/6-10d NAILS. SEE THE HEADER NAILING CHARTS ON PAGE 7.
- ③ FORWARD HEADER, 2" X 6" BY TRAILER WIDTH MINUS 1/2" (DOUBLED) (1 REQD). NAIL THE FIRST PIECE TO THE TRAILER FLOOR W/7-10d NAILS. NAIL THE SECOND PIECE TO THE FIRST W/7-20d NAILS. SEE THE HEADER NAILING CHARTS ON PAGE 7.
- ④ REAR BLOCKING ASSEMBLY B (1 REQD). SEE THE DETAIL ON PAGE 21 AND SPECIAL NOTE 3 ON PAGE 7.

SPECIAL NOTES:

1. A 45'-0" LONG BY 8'-2" WIDE (INSIDE DIMENSION) CONVENTIONAL VAN TRAILER IS SHOWN. TRAILERS OF OTHER DIMENSIONS CAN BE USED. THE LOAD ON PAGE 6 IS DEPICTED IN A VAN TRAILER EQUIPPED WITH A SQUARE FRONT OR WITH AN INSTALLED BULKHEAD. IF A TRAILER HAVING ROUNDED CORNERS IS TO BE LOADED, A FORWARD BLOCKING ASSEMBLY, AS DEPICTED ON PAGE 20, WILL BE REQUIRED.
2. ANTI-SWAY BRACES MAY BE OMITTED WHEN THE SPACE BETWEEN LATERALLY ADJACENT UNITS IS 6" OR LESS, AS MEASURED FROM PALLET ADAPTER TO PALLET ADAPTER.
3. IF THE SPACE AT THE REAR OF THE LOAD BETWEEN THE PALLET UNITS AND THE REAR DOOR IS GREATER THAN 1-1/2" BUT LESS THAN 9", USE THE "REAR BLOCKING ASSEMBLY B" AS SHOWN. IF THE SPACE AT THE REAR OF THE LOAD IS 9" OR GREATER, USE THE "REAR BLOCKING ASSEMBLY A" AS DETAILED ON PAGE 21. IF THE SPACE AT THE REAR OF THE LOAD IS 1-1/2" OR LESS, REAR BLOCKING IS NOT REQUIRED. **NOTE:** REAR BLOCKING ASSEMBLIES MAY BE REPLACED WITH NAILED HEADERS AT THE REAR OF THE LOAD, PROVIDED THE TRAILER IS CONFIGURED SUCH AS TO ALLOW NAILING IN THE AREA IN QUESTION. REFER TO PIECE MARKED ③ ON PAGE 10 AND THE HEADER NAILING CHARTS AT RIGHT FOR GUIDANCE.
4. ALTERNATE THE POSITION OF THE LATERAL VOID IN THE LOAD TO ENSURE A UNIFORM LOAD, AS DEPICTED IN THE LOAD ON PAGE 6.
5. THE DEPICTED LOAD CAN BE ADJUSTED TO SUIT THE QUANTITY TO BE SHIPPED, OR TO SUIT THE WEIGHT OF THE UNIT BEING LOADED. A LOAD CAN BE REDUCED BY A MULTIPLE OF THREE UNITS BY OMITTING ONE OR MORE FULL LOAD UNITS FROM THE LOAD; OR, ONE OR MORE UNITS CAN BE ADDED TO THE TOP TIER.
6. LEFTOVER CONTAINERS IN AN AMOUNT NOT TO EXCEED TWO CONTAINERS MAY BE SECURED TO THE TOP OF A FULL PALLET UNIT FOR SHIPMENT. REFER TO THE "PROCEDURES FOR SHIPMENT OF LEFTOVER CONTAINERS" ON PAGE 25 FOR GUIDANCE.
7. REFER TO PAGE 26 FOR GUIDANCE IN THE SHIPMENT OF PARTIAL PALLET UNITS.

FORWARD HEADER NAILING CHART •	
# NAILS	MAX. LOAD WEIGHT (LBS)
3	15,000
4	20,000
5	25,000
6	30,000
7	35,000
8	40,000
9	45,000

• HEADERS AT THE FRONT END OF A LOAD OR AT THE FRONT END OF A DIVIDED LOAD WILL BE DOUBLED 2" X 6" MATERIAL. THE NUMBER OF NAILS INDICATED ABOVE REFERS TO THE NUMBER OF NAILS USED IN EACH LAMINATION OF A HEADER, FOR EXAMPLE 8 NAILS MEANS THE FIRST BOARD IS NAILED TO THE TRAILER FLOOR W/8-10d NAILS, AND THE SECOND BOARD IS LAMINATED TO THE FIRST W/8-20d NAILS, FOR A TOTAL OF 8-10d AND 8-20d NAILS PER HEADER.

REAR HEADER NAILING CHART *	
# NAILS	MAX. LOAD WEIGHT (LBS)
6	15,000
7	17,500
8	20,000
9	22,500
10	25,000
11	27,500
12	30,000
13	32,500
14	35,000
15	37,500
16	40,000
17	42,500
18	45,000

* HEADERS AT THE REAR OF A FULL LOAD OR AT THE REAR END OF A DIVIDED LOAD WILL BE DOUBLED 2" X 4" MATERIAL. THE NUMBER OF NAILS INDICATED ABOVE REFERS TO THE NUMBER OF NAILS USED IN EACH LAMINATION OF A HEADER, FOR EXAMPLE 8 NAILS MEANS THE FIRST BOARD IS NAILED TO THE TRAILER FLOOR W/8-10d NAILS, AND THE SECOND BOARD IS LAMINATED TO THE FIRST W/8-10d NAILS, FOR A TOTAL OF 16-10d NAILS. **NOTE:** REAR HEADERS MAY BE HANDLED IN THE SAME MANNER AS FORWARD HEADERS, USING 2" X 6" MATERIAL WITH 10d AND 20d NAILS, IF DESIRED.

BILL OF MATERIAL		
LUMBER	LINEAR FEET	BOARD FEET
2" X 4"	41	28
2" X 6"	143	143
NAILS	NO. REQD	POUNDS
10d (3")	207	3-1/2
20d (4")	7	1/4

LOAD AS SHOWN

ITEM	QUANTITY	WEIGHT (APPROX)
PALLET UNIT -----	21	42,609 LBS
DUNNAGE -----		346 LBS

TOTAL WEIGHT ----- 42,955 LBS (APPROX)

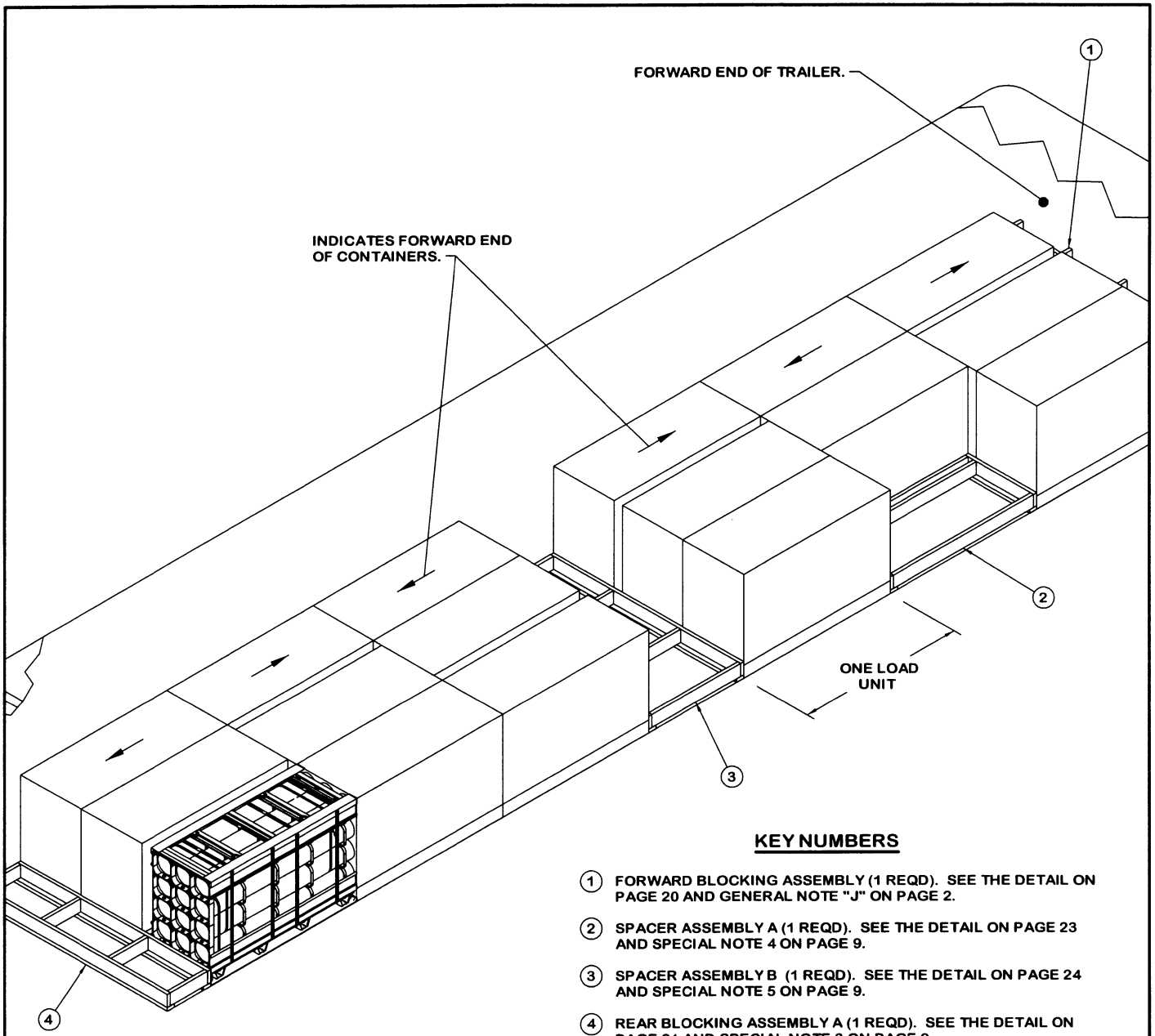

ISOMETRIC VIEW

KEY NUMBERS

- ① FORWARD BLOCKING ASSEMBLY (1 REQD). SEE THE DETAIL ON PAGE 20 AND GENERAL NOTE "J" ON PAGE 2.
- ② SPACER ASSEMBLY A (1 REQD). SEE THE DETAIL ON PAGE 23 AND SPECIAL NOTE 4 ON PAGE 9.
- ③ SPACER ASSEMBLY B (1 REQD). SEE THE DETAIL ON PAGE 24 AND SPECIAL NOTE 5 ON PAGE 9.
- ④ REAR BLOCKING ASSEMBLY A (1 REQD). SEE THE DETAIL ON PAGE 21 AND SPECIAL NOTE 3 ON PAGE 9.

SPECIAL NOTES:

1. A 42'-0" LONG BY 7'-8" WIDE (INSIDE DIMENSION) CONVENTIONAL VAN TRAILER IS SHOWN. TRAILERS OF OTHER DIMENSIONS CAN BE USED.
2. ANTI-SWAY BRACES ARE REQUIRED WHEN THE SPACE BETWEEN LATERALLY ADJACENT UNITS EXCEEDS 6", AS MEASURED FROM PALLET ADAPTER TO PALLET ADAPTER.
3. IF THE SPACE AT THE REAR OF THE LOAD BETWEEN THE PALLET UNITS AND THE REAR DOOR IS 9" OR GREATER, USE THE "REAR BLOCKING ASSEMBLY A" AS SHOWN. IF THE SPACE AT THE REAR OF THE LOAD IS GREATER THAN 1-1/2" BUT LESS THAN 9", USE THE "REAR BLOCKING ASSEMBLY B" AS DETAILED ON PAGE 21. IF THE SPACE AT THE REAR OF THE LOAD IS 1-1/2" OR LESS, REAR BLOCKING IS NOT REQUIRED. NOTE: REAR BLOCKING ASSEMBLIES MAY BE REPLACED WITH NAILED HEADERS AT THE REAR OF THE LOAD, PROVIDED THE TRAILER IS CONFIGURED SUCH AS TO ALLOW NAILING IN THE AREA IN QUESTION. REFER TO PIECE MARKED ③ ON PAGE 10 AND THE HEADER NAILING CHARTS ON PAGE 7 FOR GUIDANCE.
4. SPACER ASSEMBLY "A", SHOWN AS PIECE MARKED ② IN THE LOAD ON PAGE 8, IS ONLY SHOWN TO DEPICT A TYPICAL INSTALLATION. IF A PALLET UNIT IS LOADED IN PLACE OF THE SPACER ASSEMBLY "A", PIECE MARKED ② WILL NOT BE REQUIRED. NOTE THAT A SPACER ASSEMBLY "A" MUST BE POSITIONED WHERE THERE WILL BE A PALLET UNIT AT EACH END. A SPACER ASSEMBLY "A" MUST NOT BE POSITIONED ADJACENT TO THE FORWARD BLOCKING ASSEMBLY, PIECE MARKED ①.
5. SPACER ASSEMBLY "B", SHOWN AS PIECE MARKED ③ IN THE LOAD ON PAGE 8, IS TO BE USED FOR THE PURPOSE OF PROVIDING FOR PROPER WEIGHT DISTRIBUTION, AND IS SHOWN AS TYPICAL ONLY. IF THE TRAILER TO BE LOADED IS LONGER THAN 42', THE LOCATION OF THE ASSEMBLY, AND/OR THE STRUT LENGTHS, MAY BE DIFFERENT FROM WHAT IS SHOWN. IF A SHORTER TRAILER IS USED FOR THE DEPICTED LOAD, THIS ASSEMBLY MAY NOT BE REQUIRED. NOTE THAT A SPACER ASSEMBLY "B" MUST NOT BE POSITIONED ADJACENT TO THE FORWARD BLOCKING ASSEMBLY, PIECE MARKED ①.
6. ALTERNATE THE POSITION OF THE LATERAL VOID IN THE LOAD TO ENSURE A UNIFORM LOAD, AS DEPICTED IN THE LOAD ON PAGE 8.
7. THE DEPICTED LOAD CAN BE ADJUSTED TO SUIT THE QUANTITY TO BE SHIPPED, OR TO SUIT THE WEIGHT OF THE UNIT BEING LOADED. A LOAD CAN BE REDUCED BY A MULTIPLE OF THREE UNITS BY OMITTING ONE OR MORE FULL LOAD UNITS FROM THE LOAD; OR, ONE OR MORE UNITS CAN BE ADDED TO OR OMITTED FROM THE LOAD.
8. LEFTOVER CONTAINERS IN AN AMOUNT NOT TO EXCEED TWO CONTAINERS MAY BE SECURED TO THE TOP OF A FULL PALLET UNIT FOR SHIPMENT. REFER TO THE "PROCEDURES FOR SHIPMENT OF LEFTOVER CONTAINERS" ON PAGE 25 FOR GUIDANCE.
9. REFER TO PAGE 26 FOR GUIDANCE IN THE SHIPMENT OF PARTIAL PALLET UNITS.

BILL OF MATERIAL		
LUMBER	LINEAR FEET	BOARD FEET
2" X 4"	51	34
2" X 6"	101	101
NAILS	NO. REQD	POUNDS
10d (3")	134	2-1/4

LOAD AS SHOWN

<u>ITEM</u>	<u>QUANTITY</u>	<u>WEIGHT (APPROX)</u>
PALLET UNIT -----	17 -----	34,493 LBS
DUNNAGE -----		273 LBS
TOTAL WEIGHT -----		34,766 LBS (APPROX)

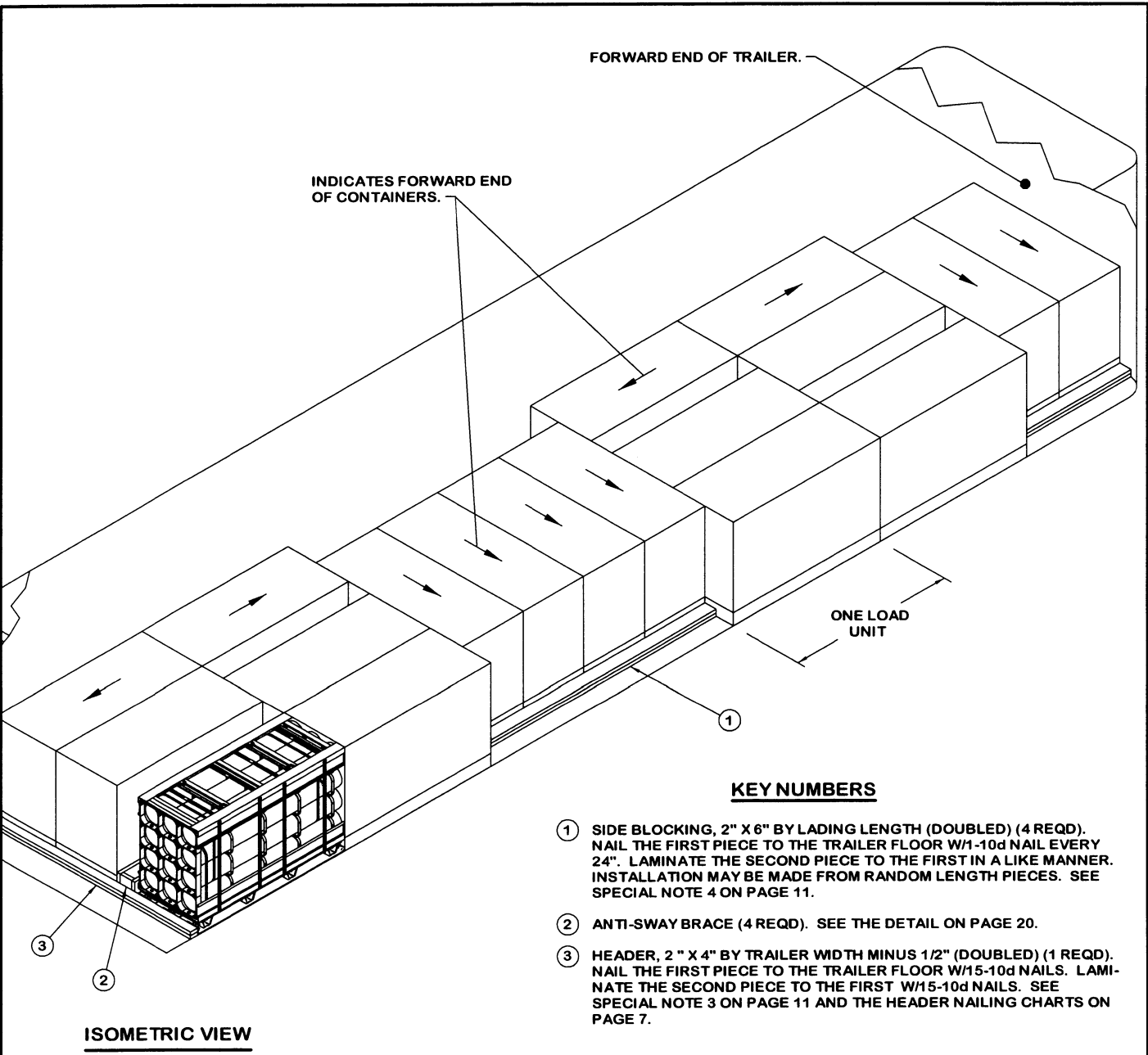

ISOMETRIC VIEW

KEY NUMBERS

- ① SIDE BLOCKING, 2" X 6" BY LADING LENGTH (DOUBLED) (4 REQD). NAIL THE FIRST PIECE TO THE TRAILER FLOOR W/1-10d NAIL EVERY 24". LAMINATE THE SECOND PIECE TO THE FIRST IN A LIKE MANNER. INSTALLATION MAY BE MADE FROM RANDOM LENGTH PIECES. SEE SPECIAL NOTE 4 ON PAGE 11.
- ② ANTI-SWAY BRACE (4 REQD). SEE THE DETAIL ON PAGE 20.
- ③ HEADER, 2" X 4" BY TRAILER WIDTH MINUS 1/2" (DOUBLED) (1 REQD). NAIL THE FIRST PIECE TO THE TRAILER FLOOR W/15-10d NAILS. LAMINATE THE SECOND PIECE TO THE FIRST W/15-10d NAILS. SEE SPECIAL NOTE 3 ON PAGE 11 AND THE HEADER NAILING CHARTS ON PAGE 7.

SPECIAL NOTES:

1. A 40'-0" LONG BY 8'-2" WIDE (INSIDE DIMENSION) CONVENTIONAL VAN TRAILER IS SHOWN. TRAILERS OF OTHER DIMENSIONS CAN BE USED.
2. ANTI-SWAY BRACES MAY BE OMITTED WHEN THE SPACE BETWEEN LATERALLY ADJACENT UNITS IS 6" OR LESS, AS MEASURED FROM PALLET ADAPTER TO PALLET ADAPTER.
3. IF THE SPACE AT THE REAR OF THE LOAD, BETWEEN THE PALLET UNITS AND THE REAR DOOR IS 1-1/2" OR LESS, REAR BLOCKING IS NOT REQUIRED. IF THE SPACE AT THE REAR OF THE LOAD IS GREATER THAN 1-1/2" BUT LESS THAN 9", USE THE "REAR BLOCKING ASSEMBLY B" AS DETAILED ON PAGE 21 OR A NAILED HEADER, AS SHOWN. IF THE SPACE AT THE REAR OF THE LOAD IS 9" OR GREATER, USE THE "REAR BLOCKING ASSEMBLY A" AS DETAILED ON PAGE 21 OR A NAILED HEAD, AS SHOWN. IF THE TRAILER IS EQUIPPED WITH A METAL THRESHOLD PLATE AND IT INTERFERES WITH THE NAILING OF PIECE MARKED ③, ONE OF THE REAR BLOCKING ASSEMBLIES DESCRIBED ABOVE MUST BE INSTALLED.
4. IF DESIRED, SIDE SPACERS "A" AND/OR "B", AS DEPICTED ON PAGES 22 AND 23, MAY BE USED IN LIEU OF THE SIDE BLOCKING, PIECE MARKED ①. SEE THE LOAD ON PAGE 12 FOR DETAILS.
5. ALTERNATE THE POSITION OF THE LATERAL VOID IN THREE-WIDE LOAD UNITS TO ENSURE A UNIFORM LOAD, AS DEPICTED IN THE LOAD ON PAGE 10.
6. THE LOADING PROCEDURES SHOWN ON PAGE 10 ARE LIMITED TO 1-LAYER LOADS; PALLET UNITS WILL NOT BE STACKED.
7. THE DEPICTED LOAD CAN BE ADJUSTED TO SUIT THE QUANTITY TO BE SHIPPED, OR TO SUIT THE WEIGHT OF THE UNIT BEING LOADED. A LOAD CAN BE INCREASED BY REPLACING SOME OF THE 1-WIDE UNITS WITH 3-WIDE UNITS, OR THE LOAD CAN BE REDUCED BY REPLACING 3-WIDE PORTIONS WITH SINGLE UNITS.
8. LEFTOVER CONTAINERS IN AN AMOUNT NOT TO EXCEED TWO CONTAINERS MAY BE SECURED TO THE TOP OF A FULL PALLET UNIT FOR SHIPMENT. REFER TO THE "PROCEDURES FOR SHIPMENT OF LEFTOVER CONTAINERS" ON PAGE 25 FOR GUIDANCE.
9. REFER TO PAGE 26 FOR GUIDANCE IN THE SHIPMENT OF PARTIAL PALLET UNITS.

BILL OF MATERIAL		
LUMBER	LINEAR FEET	BOARD FEET
2" X 4"	17	12
2" X 6"	118	118
NAILS	NO. REQD	POUNDS
10d (3")	138	2-1/4

LOAD AS SHOWN

ITEM	QUANTITY	WEIGHT (APPROX)
PALLET UNIT	18	36,522 LBS
DUNNAGE		263 LBS
TOTAL WEIGHT		36,785 LBS (APPROX)

**COMBINATION 1-WIDE AND 3-WIDE
18-UNIT LOAD IN A 40'-0" LONG BY 8'-2" WIDE CONVENTIONAL VAN TRAILER**

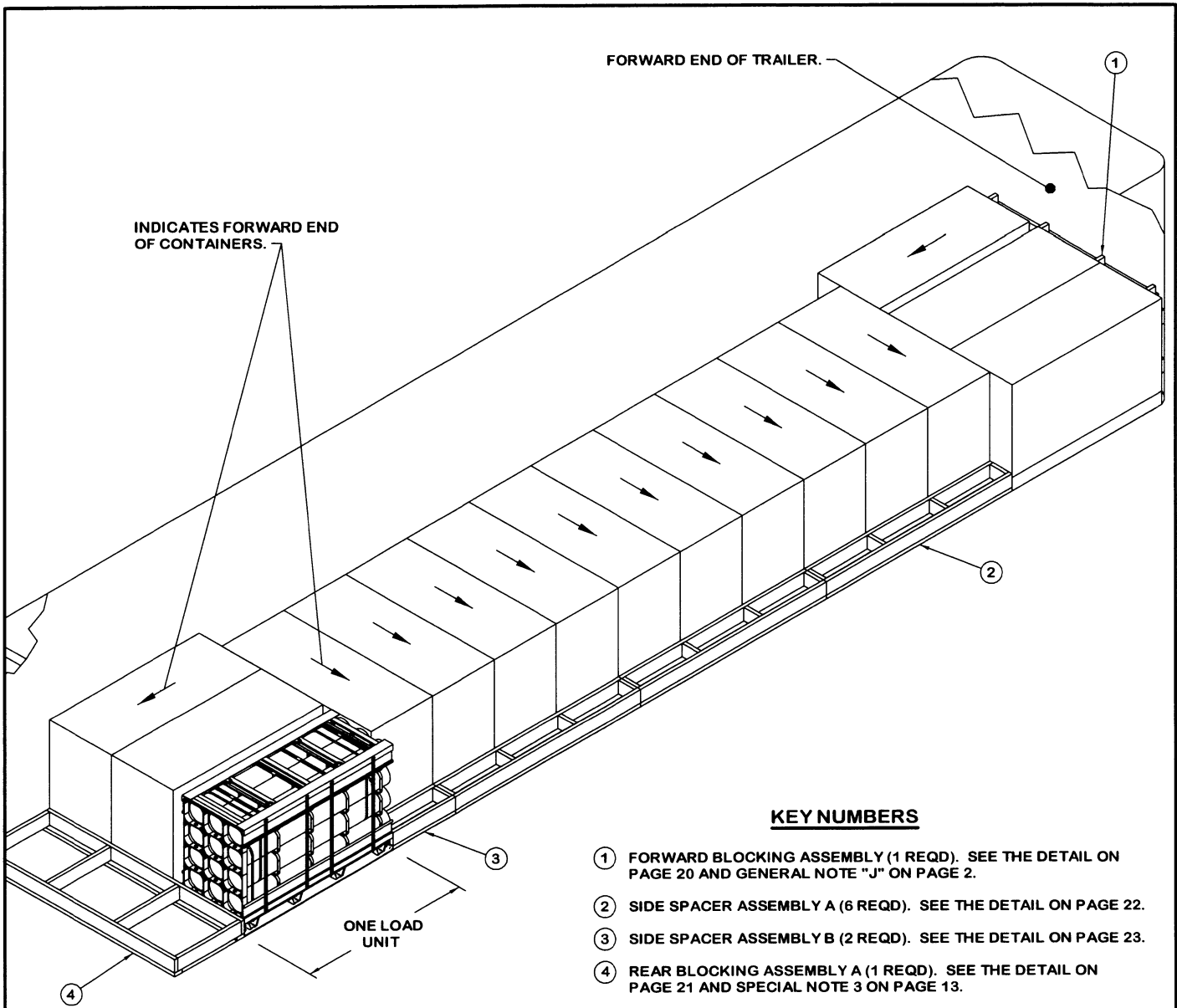

ISOMETRIC VIEW

SPECIAL NOTES:

1. A 40'-0" LONG BY 7'-8" WIDE (INSIDE DIMENSION) CONVENTIONAL VAN TRAILER IS SHOWN. TRAILERS OF OTHER DIMENSIONS CAN BE USED.
2. ANTI-SWAY BRACES ARE REQUIRED WHEN THE SPACE BETWEEN Laterally adjacent units exceeds 6", as measured from pallet adapter to pallet adapter.
3. IF THE SPACE AT THE REAR OF THE LOAD BETWEEN THE PALLET UNITS AND THE REAR DOOR IS 9" OR GREATER, USE THE "REAR BLOCKING ASSEMBLY A" AS SHOWN. IF THE SPACE AT THE REAR OF THE LOAD IS GREATER THAN 1-1/2" BUT LESS THAN 9", USE THE "REAR BLOCKING ASSEMBLY B" AS DETAILED ON PAGE 21. IF THE SPACE AT THE REAR OF THE LOAD IS 1-1/2" OR LESS, REAR BLOCKING IS NOT REQUIRED. NOTE: REAR BLOCKING ASSEMBLIES MAY BE REPLACED WITH NAILED HEADERS AT THE REAR OF THE LOAD, PROVIDED THE TRAILER IS CONFIGURED SUCH AS TO ALLOW NAILING IN THE AREA IN QUESTION. REFER TO PIECE MARKED ③ ON PAGE 10 AND THE HEADER NAILING CHARTS ON PAGE 7 FOR GUIDANCE.
4. IF THE TRAILER BEING LOADED IS EQUIPPED WITH A WOOD OR WOOD AND METAL FLOOR, AND IF DESIRED, NAILED SIDE BLOCKING MAY BE USED IN LIEU OF THE SIDE SPACERS, PIECES MARKED ② AND ③. SIDE BLOCKING SHOULD BE DOUBLED 2" X 6" MATERIAL. SEE THE LOAD ON PAGE 10 FOR DETAILS.
5. ALTERNATE THE POSITION OF THE LATERAL VOID IN THREE-WIDE LOAD UNITS TO ENSURE A UNIFORM LOAD, AS DEPICTED IN THE LOAD ON PAGE 12.
6. THE LOADING PROCEDURES SHOWN ON PAGE 12 ARE LIMITED TO 1-LAYER LOADS; PALLET UNITS WILL NOT BE STACKED.
7. THE DEPICTED LOAD CAN BE ADJUSTED TO SUIT THE QUANTITY TO BE SHIPPED, OR TO SUIT THE WEIGHT OF THE UNIT BEING LOADED. A LOAD CAN BE INCREASED BY REPLACING SOME OF THE 1-WIDE UNITS WITH 3-WIDE UNITS, OR THE LOAD CAN BE REDUCED BY REPLACING 3-WIDE PORTIONS WITH SINGLE UNITS.
8. LEFTOVER CONTAINERS IN AN AMOUNT NOT TO EXCEED TWO CONTAINERS MAY BE SECURED TO THE TOP OF A FULL PALLET UNIT FOR SHIPMENT. REFER TO THE "PROCEDURES FOR SHIPMENT OF LEFTOVER CONTAINERS" ON PAGE 25 FOR GUIDANCE.
9. REFER TO PAGE 26 FOR GUIDANCE IN THE SHIPMENT OF PARTIAL PALLET UNITS.

BILL OF MATERIAL		
LUMBER	LINEAR FEET	BOARD FEET
2" X 4"	126	84
2" X 6"	169	169
NAILS	NO. REQD	POUNDS
10d (3")	338	5-1/4

LOAD AS SHOWN

<u>ITEM</u>	<u>QUANTITY</u>	<u>WEIGHT (APPROX)</u>
PALLET UNIT -----	16 -----	32,464 LBS
DUNNAGE -----		512 LBS
TOTAL WEIGHT -----		36,976 LBS (APPROX)

**COMBINATION 1-WIDE AND 3-WIDE
16-UNIT LOAD IN A 40'-0" LONG BY 7'-8" WIDE CONVENTIONAL VAN TRAILER**

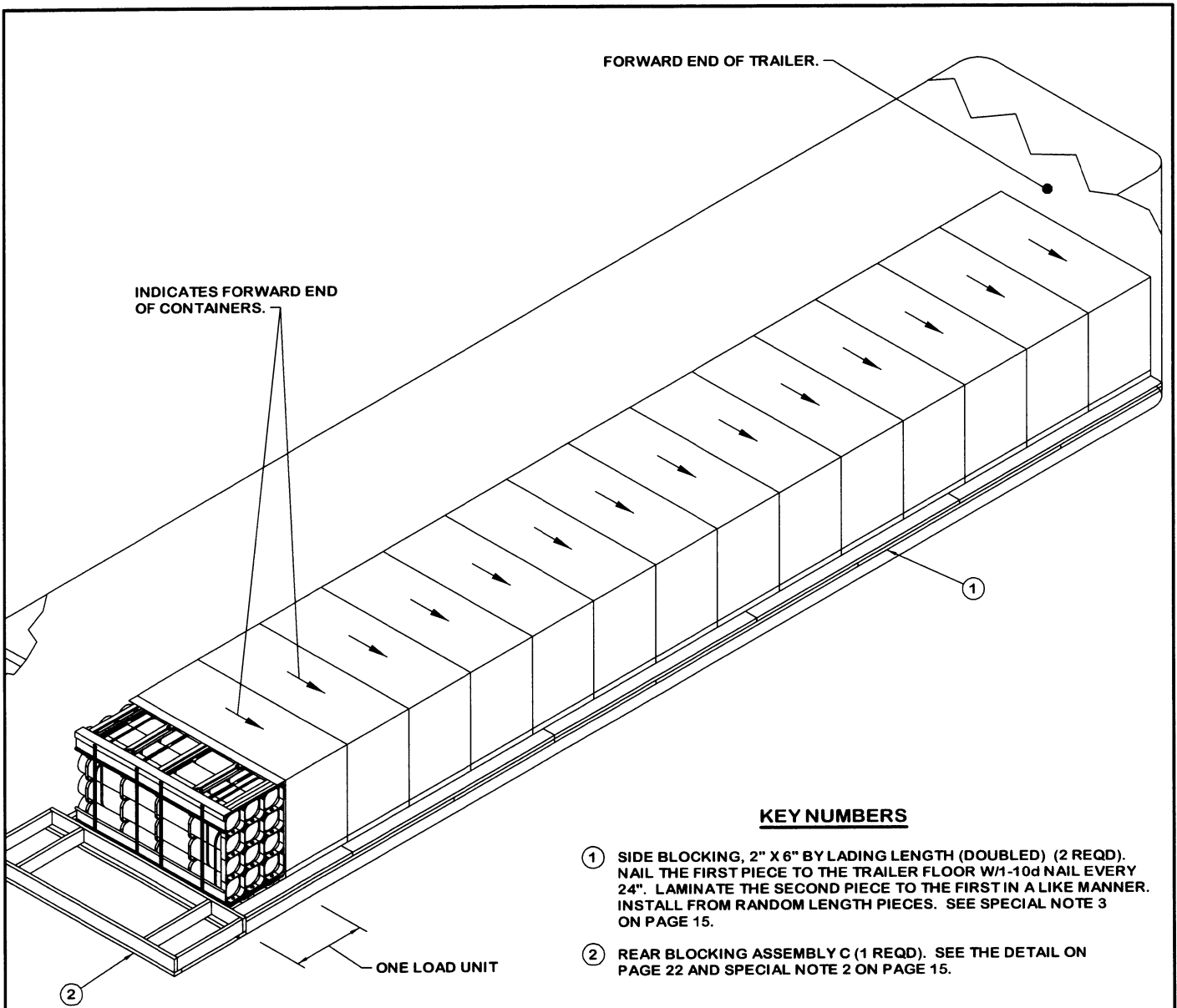

KEY NUMBERS

- ① SIDE BLOCKING, 2" X 6" BY LADING LENGTH (DOUBLED) (2 REQD). NAIL THE FIRST PIECE TO THE TRAILER FLOOR W/1-10d NAIL EVERY 24". LAMINATE THE SECOND PIECE TO THE FIRST IN A LIKE MANNER. INSTALL FROM RANDOM LENGTH PIECES. SEE SPECIAL NOTE 3 ON PAGE 15.
- ② REAR BLOCKING ASSEMBLY C (1 REQD). SEE THE DETAIL ON PAGE 22 AND SPECIAL NOTE 2 ON PAGE 15.

SPECIAL NOTES:

1. A 40'-0" LONG BY 7'-8" WIDE (INSIDE DIMENSION) CONVENTIONAL VAN TRAILER IS SHOWN. TRAILERS OF OTHER DIMENSIONS CAN BE USED.
2. IF THE SPACE AT THE REAR OF THE LOAD BETWEEN THE PALLET UNITS AND THE REAR DOOR IS 9" OR GREATER, USE THE "REAR BLOCKING ASSEMBLY C" AS SHOWN. IF THE SPACE AT THE REAR OF THE LOAD IS GREATER THAN 1-1/2" BUT LESS THAN 9", USE THE "REAR BLOCKING ASSEMBLY B" AS DETAILED ON PAGE 21. IF THE SPACE AT THE REAR OF THE LOAD IS 1-1/2" OR LESS, REAR BLOCKING IS NOT REQUIRED. NOTE: REAR BLOCKING ASSEMBLIES MAY BE REPLACED WITH NAILED HEADERS AT THE REAR OF THE LOAD, PROVIDED THE TRAILER IS CONFIGURED SUCH AS TO ALLOW NAILING IN THE AREA IN QUESTION. REFER TO PIECE MARKED ③ ON PAGE 10 AND THE HEADER NAILING CHARTS ON PAGE 7 FOR GUIDANCE.
3. IF DESIRED, SIDE SPACERS "A" AND/OR "B", AS DEPICTED ON PAGES 22 AND 23, MAY BE USED IN LIEU OF THE SIDE BLOCKING, PIECE MARKED ①. SEE THE LOAD ON PAGE 12 FOR DETAILS.
4. THE LOADING PROCEDURES SHOWN ON PAGE 14 ARE LIMITED TO 1-LAYER LOADS; PALLET UNITS WILL NOT BE STACKED.
5. THE DEPICTED LOAD CAN BE ADJUSTED TO SUIT THE QUANTITY TO BE SHIPPED, OR TO SUIT THE WEIGHT OF THE UNIT BEING LOADED.
6. LEFTOVER CONTAINERS IN AN AMOUNT NOT TO EXCEED TWO CONTAINERS MAY BE SECURED TO THE TOP OF A FULL PALLET UNIT FOR SHIPMENT. REFER TO THE "PROCEDURES FOR SHIPMENT OF LEFTOVER CONTAINERS" ON PAGE 25 FOR GUIDANCE.
7. REFER TO PAGE 26 FOR GUIDANCE IN THE SHIPMENT OF PARTIAL PALLET UNITS.

BILL OF MATERIAL		
LUMBER	LINEAR FEET	BOARD FEET
2" X 4"	16	11
2" X 6"	173	173
NAILS	NO. REQD	POUNDS
10d (3")	110	1-3/4

LOAD AS SHOWN

<u>ITEM</u>	<u>QUANTITY</u>	<u>WEIGHT (APPROX)</u>
PALLET UNIT -----	15 -----	30,435 LBS
DUNNAGE -----		370 LBS
TOTAL WEIGHT -----		30,805 LBS (APPROX)

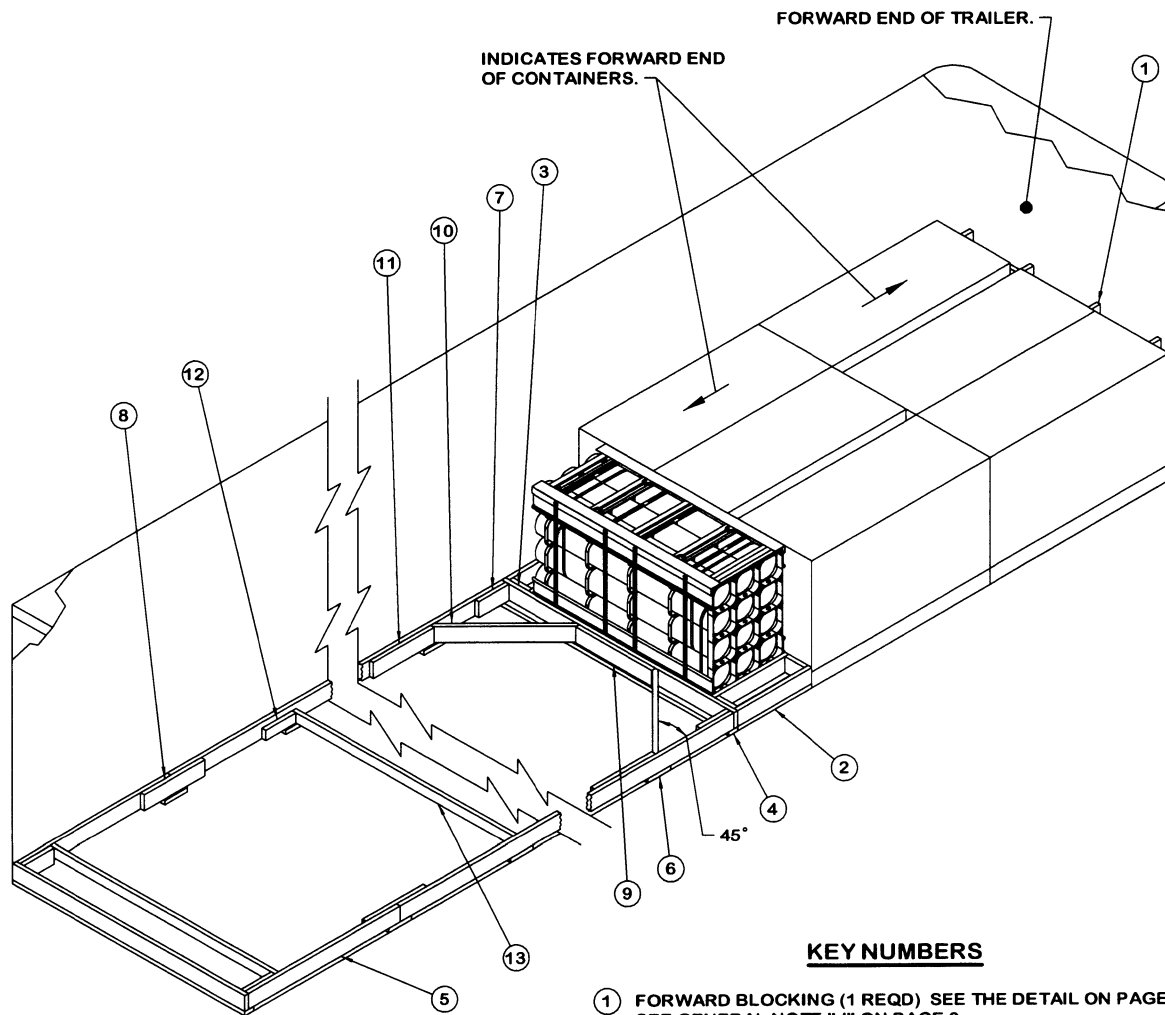

ISOMETRIC VIEW

(KEY NUMBERS CONTINUED)

- ⑩ DIAGONAL BRACE, 2" X 6" BY CUT TO FIT (2 REQD). DOUBLE BEVEL EACH END WITH 45° CUTS. INSTALL AT A 45° ANGLE AS SHOWN AND TOENAIL TO THE ADJACENT HEADER AND SIDE STRUT, PIECES MARKED ③ AND ⑤, W/2-16d NAILS AT EACH END.
- ⑪ BACK-UP CLEAT, 2" X 6" X 24" (2 REQD). NAIL TO A SIDE STRUT, PIECE MARKED ⑤, W/8-10d NAILS.
- ⑫ STRUT BRACE RETAINING CLEAT, 2" X 4" X 12" (AS REQD). NAIL TO A SIDE STRUT, PIECE MARKED ⑤, W/3-10d NAILS. SEE SPECIAL NOTE 5 ON PAGE 17.
- ⑬ STRUT BRACE, 2" X 4" BY TRAILER WIDTH MINUS 3" IN LENGTH (MINIMUM OF ONE REQUIRED). NAIL TO THE POCKET CLEATS, PIECES MARKED ⑦, AND/OR TO THE STRUT BRACE RETAINING CLEATS, PIECES MARKED ⑫, W/2-12d NAILS AT EACH END. SEE SPECIAL NOTE 5 ON PAGE 17.

KEY NUMBERS

- ① FORWARD BLOCKING (1 REQD) SEE THE DETAIL ON PAGE 20. SEE GENERAL NOTE "J" ON PAGE 2.
- ② SIDE SPACER ASSEMBLY B (2 REQD). SEE THE DETAIL ON PAGE 23. SEE SPECIAL NOTE 3 ON PAGE 17.
- ③ HEADER, 2" X 6" BY TRAILER WIDTH MINUS 1/2" IN LENGTH (2 REQD). SEE SPECIAL NOTE 7 ON PAGE 17.
- ④ HEADER AND SIDE STRUT SUPPORT, 2" X 4" BY TRAILER WIDTH MINUS 1/2" IN LENGTH (2 REQD). NAIL TO THE BOTTOM EDGE OF A HEADER, PIECE MARKED ③, W/1-10d NAIL EVERY 8".
- ⑤ SIDE STRUT, 2" X 6" BY CUT TO FIT BETWEEN THE FORWARD AND REAR HEADERS, PIECES MARKED ③ (2 REQD). SEE SPECIAL NOTE 4 ON PAGE 17.
- ⑥ RISER PIECE, 2" X 4" X 9" (AS REQD). CENTER UNDER THE JOINTS OF PIECES MARKED ⑩ AND ⑪, ⑫ AND ⑬, AND UNDER THE SPLICE OF PIECES MARKED ⑤ IF APPLICABLE. NAIL TO SIDE STRUT MARKED ⑤ W/2-10d NAILS.
- ⑦ POCKET CLEAT, 2" X 6" X 12" (4 REQD). NAIL TO A SIDE STRUT, PIECE MARKED ⑤, W/3-10d NAILS. TOENAIL TO THE ADJACENT HEADER, PIECE MARKED ③, W/3-12d NAILS.
- ⑧ SPLICE PIECE, 2" X 6" X 24" (AS REQD). CENTER ON JOINT OF PIECES MARKED ⑤ AND NAIL TO SIDE STRUT MARKED ⑤ W/4-10d NAILS AT EACH END. SEE SPECIAL NOTE 4 ON PAGE 17.
- ⑨ CENTER CLEAT, 2" X 6" X 30" (1 REQD). NAIL TO A HEADER, PIECE MARKED ③, W/6-10d NAILS.

(CONTINUED AT LEFT)

SPECIAL NOTES:

1. A 7'-8" WIDE (INSIDE DIMENSION) CONVENTIONAL VAN TRAILER IS SHOWN. TRAILERS OF OTHER WIDTHS CAN BE USED.
2. ANTI-SWAY BRACES ARE REQUIRED WHEN THE SPACE BETWEEN LATERALLY ADJACENT UNITS EXCEEDS 6", AS MEASURED FROM PALLET ADAPTER TO PALLET ADAPTER.
3. THE SIDE SPACER ASSEMBLIES, PIECES MARKED ②, ARE SHOWN ONLY TO DEPICT A TYPICAL INSTALLATION. SIDE SPACER ASSEMBLIES WILL BE USED WHEN A PALLET UNIT IS LOADED WITH THE CONTAINERS PARALLEL TO THE TRAILER WIDTH. THEY MAY OR MAY NOT BE REQUIRED, DEPENDING ON THE QUANTITY OF PALLET UNITS TO BE SHIPPED.
4. DEPENDING ON THE NUMBER OF UNITS BEING LOADED, EACH OF THE SIDE STRUTS, PIECES MARKED ⑤, MAY NEED TO BE FORMED FROM MORE THAN ONE PIECE OF MATERIAL. IF SUCH IS THE CASE, THE SIDE STRUTS MUST BE SPLICED. SPLICING CAN BE ACCOMPLISHED BY CENTERING A 2" X 6" X 24" PIECE ON THE JOINT OF THE SIDE STRUTS AND NAILING IT TO THE SIDE STRUTS W/4-10d NAILS AT EACH END. CAUTION: A RISER PIECE, PIECE MARKED ⑥, MUST BE POSITIONED UNDER EACH SPLICE JOINT. IF DESIRED, THE STRUT BRACE PIECE(S), PIECE MARKED ⑬, MAY BE NAILED TO THE SPLICE PIECES IN LIEU OF USING ADDITIONAL STRUT BRACE RETAINING CLEATS, PIECE MARKED ⑫.
5. ALL LTL LOADS, REGARDLESS OF THEIR SIZE, REQUIRE ONE STRUT BRACE POSITIONED AT THE REAR OF THE TRAILER AND NAILED TO PIECE MARKED ⑦. IF THE SIDE STRUTS, PIECE MARKED ⑤, ARE LONGER THAN 7'-0", AN ADDITIONAL STRUT BRACE, PIECE MARKED ⑬, AND TWO STRUT BRACE RETAINING CLEATS, PIECE MARKED ⑫, AND TWO RISER PIECES MARKED ⑥, MUST BE APPLIED FOR EVERY 7'-0" OF SIDE STRUT LENGTH.
6. THE "K-BRACE" BLOCKING, SHOWN AS PIECES MARKED ③ THRU ⑬, IS ADEQUATE FOR RETAINING A MAXIMUM LTL LOAD OF 20,000 POUNDS.
7. TRAILERS EQUIPPED WITH ROLL-UP TYPE DOORS MAY BE USED; HOWEVER, THE NAILED-HEADER METHOD OF REAR BLOCKING MUST BE INSTALLED IN LIEU OF THE "K-BRACE" TYPE BLOCKING. REFER TO PIECE MARKED ③ ON PAGE 10 AND THE HEADER NAILING CHARTS ON PAGE 7 FOR GUIDANCE. NOTE THAT THE NAILED-HEADER METHOD OF REAR BLOCKING MAY ALSO BE USED IN TRAILERS EQUIPPED WITH HINGED DOORS AND NAILABLE FLOORS, AND MAY BE USED IN LIEU OF PIECES MARKED ③ THRU ⑬ WHICH APPLY TO TRAILERS HAVING NON-NAILABLE FLOORS.
8. LEFTOVER CONTAINERS IN AN AMOUNT NOT TO EXCEED TWO CONTAINERS MAY BE SECURED TO THE TOP OF A FULL PALLET UNIT FOR SHIPMENT. REFER TO THE "PROCEDURES FOR SHIPMENT OF LEFTOVER CONTAINERS" ON PAGE 25 FOR GUIDANCE.
9. REFER TO PAGE 26 FOR GUIDANCE IN THE SHIPMENT OF PARTIAL PALLET UNITS.

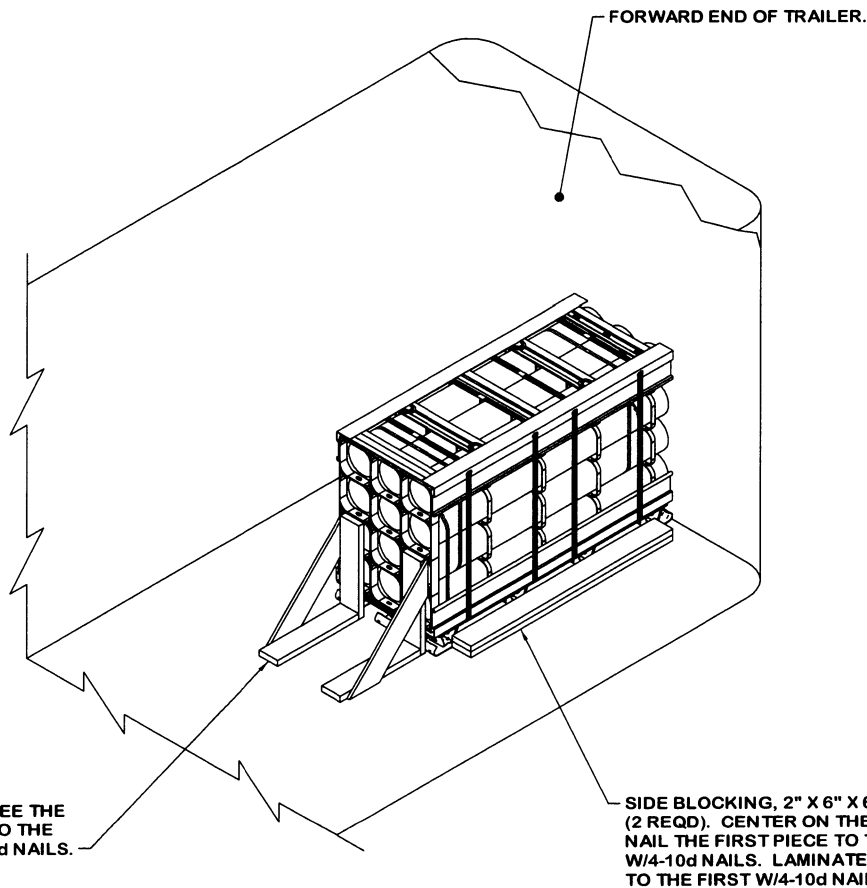

ISOMETRIC VIEW

SPECIAL NOTES:

1. A 7'-8" WIDE (INSIDE DIMENSION) CONVENTIONAL VAN TRAILER WHICH HAS A NAILABLE FLOOR IS SHOWN. TRAILERS OF OTHER WIDTHS CAN BE USED.
2. THE POSITIONING OF A UNIT IS OPTIONAL. LTL BRACES MUST CONTACT EITHER THE AFT OR FORWARD END OF THE UNIT, NOT THE SIDES. UNITS MAY ALSO BE LOCATED IN THE CORNER OF THE TRAILER, IF DESIRED. IF THE TRAILER DOES NOT HAVE A SQUARE FRONT, A FORWARD BLOCKING ASSEMBLY MUST BE INSTALLED WHEN POSITIONING A UNIT IN THE CORNER OF THE TRAILER. SEE THE DETAIL ON PAGE 20.
3. MORE THAN ONE PALLET UNIT CAN BE SHIPPED, PROVIDING THE CAPACITY OF THE LTL BRACES IS NOT EXCEEDED. THE LOAD SHOULD BE FORMED IN ROWS, WITH THE UNITS POSITIONED AGAINST OPPOSITE SIDEWALLS. THE PROPER ANTI-SWAY BRACES, IF REQUIRED, WILL BE INSTALLED BETWEEN THE LATERALLY ADJACENT UNITS. SEE THE DETAIL ON PAGE 20.
4. EACH LTL BRACE AS APPLIED FOR LONGITUDINAL BRACING WILL SUPPORT 2,000 POUNDS OF LADING; HOWEVER, NOT LESS THAN TWO BRACES WILL BE USED AGAINST EACH PALLET UNIT ACROSS THE WIDTH OF THE TRAILER.

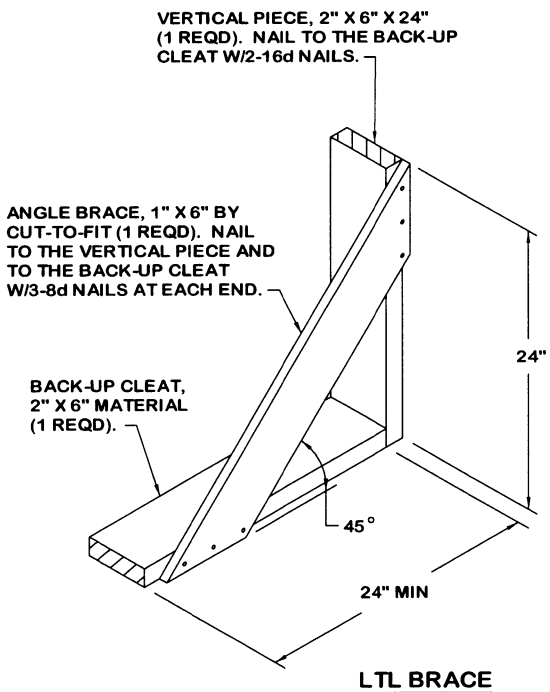

TYPICAL LTL (1-UNIT) LOAD IN A CONVENTIONAL VAN TRAILER

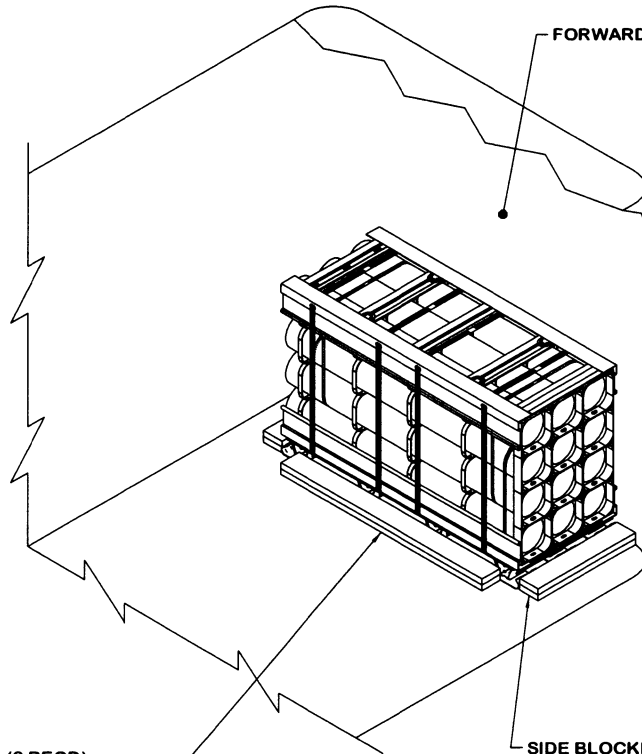

HEADER, 2" X 6" X 60" (DOUBLED) (2 REQD). ALIGN WITH THE PALLET SKIDS. NAIL THE FIRST PIECE TO THE TRAILER FLOOR W/4-10d NAILS. LAMINATE THE SECOND PIECE TO THE FIRST W/4-10d NAILS. SEE SPECIAL NOTE 4 BELOW.

SIDE BLOCKING, 2" X 6" X 29" (DOUBLED) (2 REQD). ALIGN WITH THE PALLET SKID. NAIL THE FIRST PIECE TO THE TRAILER FLOOR W/4-10d NAILS. LAMINATE THE SECOND PIECE TO THE FIRST W/4-10d NAILS.

ISOMETRIC VIEW

SPECIAL NOTES:

1. A 8'-2" WIDE (INSIDE DIMENSION) CONVENTIONAL VAN TRAILER WHICH HAS A NAILABLE FLOOR IS SHOWN. TRAILERS OF OTHER WIDTHS CAN BE USED.
2. THE POSITIONING OF A UNIT IS OPTIONAL. UNITS MAY BE LOCATED IN THE CORNER OF THE TRAILER. IF THE TRAILER DOES NOT HAVE A SQUARE FRONT, A FORWARD BLOCKING ASSEMBLY MUST BE INSTALLED WHEN POSITIONING A UNIT IN THE CORNER OF THE TRAILER. SEE THE DETAIL ON PAGE 20.
3. MORE THAN ONE PALLET UNIT CAN BE SHIPPED. THE LOAD SHOULD BE FORMED IN ROWS, WITH THE UNITS POSITIONED AGAINST OPPOSITE SIDEWALLS. THE PROPER ANTI-SWAY BRACES, IF REQUIRED, WILL BE INSTALLED BETWEEN THE LATERALLY ADJACENT UNITS. SEE THE DETAIL ON PAGE 20.
4. THE HEADER AS APPLIED ABOVE FOR LONGITUDINAL BRACING WILL SUPPORT 10,000 POUNDS OF LADING; A TRAILER WIDTH HEADER WILL SUPPORT UP TO A FULL TRAILER LOAD OF PALLET UNITS. SEE THE HEADER NAILING CHARTS ON PAGE 7.

BUFFER PIECE, 2" X 6" X 70-1/2"
(2 REQD). NAIL TO THE STRUTS
W/3-10d NAILS AT EACH END.

FABRICATE TO FIT BETWEEN
LATERALLY ADJACENT
PALLET UNITS.

RISER PIECE, 2" X 6" BY CUT-TO-FIT
(2 REQD). NAIL TO THE BUFFER PIECES
W/1-10d NAIL EACH AND TO THE STRUTS
W/2-10d NAILS.

STRUT, 2" X 6" BY CUT-
TO-FIT (2 REQD).

ANTI-SWAY BRACE

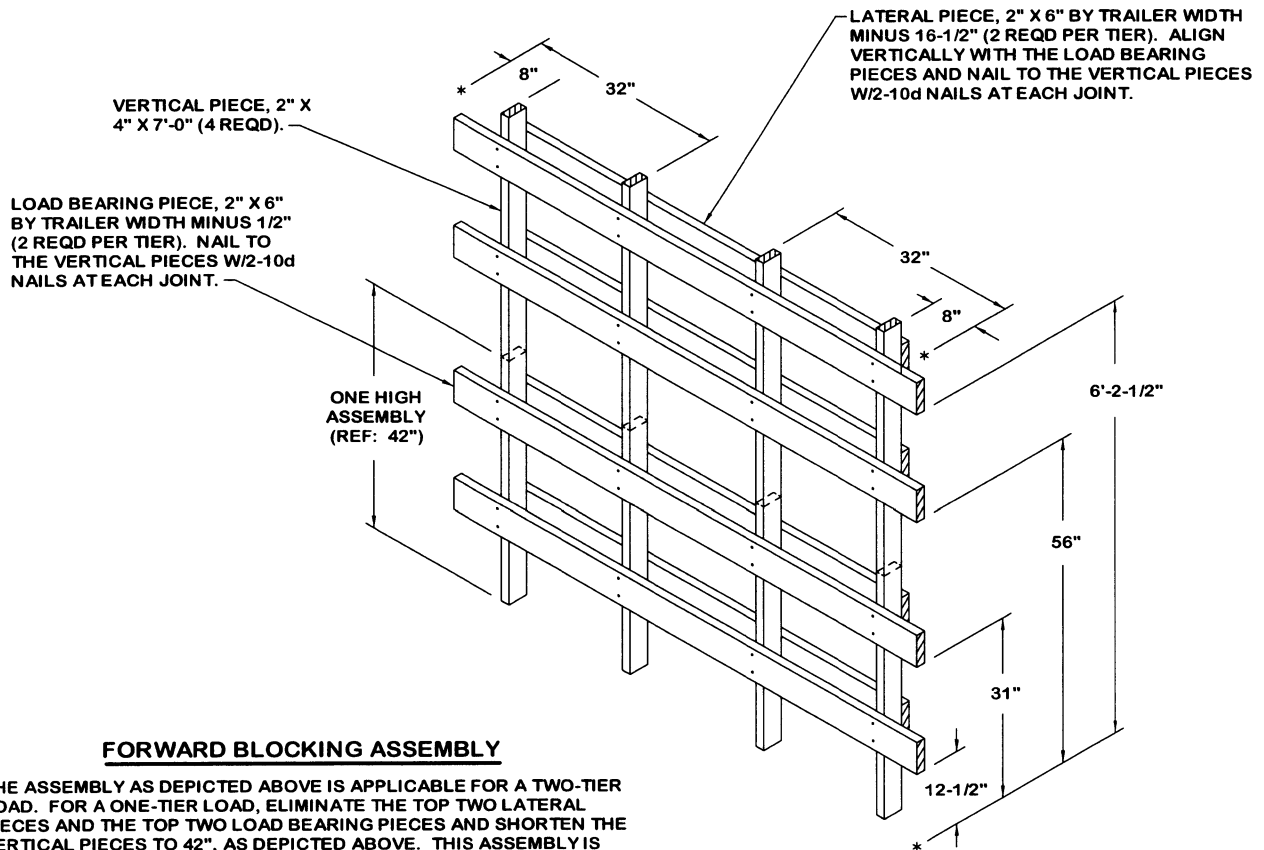

FORWARD BLOCKING ASSEMBLY

THE ASSEMBLY AS DEPICTED ABOVE IS APPLICABLE FOR A TWO-TIER LOAD. FOR A ONE-TIER LOAD, ELIMINATE THE TOP TWO LATERAL PIECES AND THE TOP TWO LOAD BEARING PIECES AND SHORTEN THE VERTICAL PIECES TO 42", AS DEPICTED ABOVE. THIS ASSEMBLY IS DESIGNED FOR USE AT THE FRONT END OF A TRAILER HAVING ROUNDED CORNERS, AND IS APPLICABLE FOR A CORNER RADIUS OF NOT MORE THAN 6-1/2". IF THE RADIUS IS FROM 6-1/2" TO 8", 2" X 6" VERTICAL PIECES WILL BE USED IN LIEU OF THE 2" X 4" PIECES. IF THE TRAILER TO BE LOADED HAS LARGE-ANGLED CORNERS AT THE FORWARD END, REFER TO PAGE 27 FOR GUIDANCE.

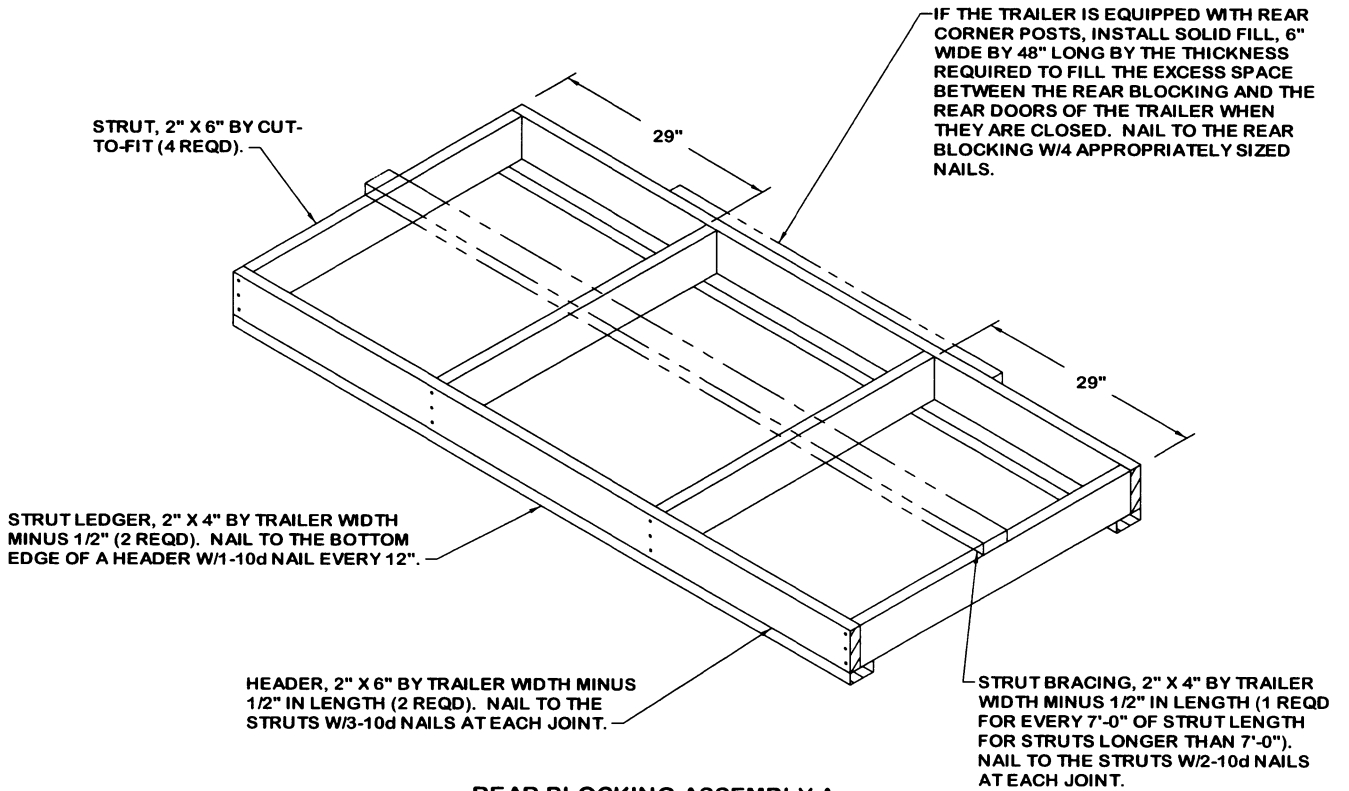

REAR BLOCKING ASSEMBLY A

THIS ASSEMBLY IS DESIGNED FOR USE AT THE REAR OF A LOAD WHEN THE SPACE BETWEEN THE LADING AND THE TRAILER DOOR IS MORE THAN 9" AND THREE ROWS OF PALLET UNITS ARE LOADED ADJACENT TO THE TRAILER DOORS. NOTE THAT THE ABOVE VIEW IS ROTATED 180° FROM THE POSITION IN WHICH IT WILL BE INSTALLED.

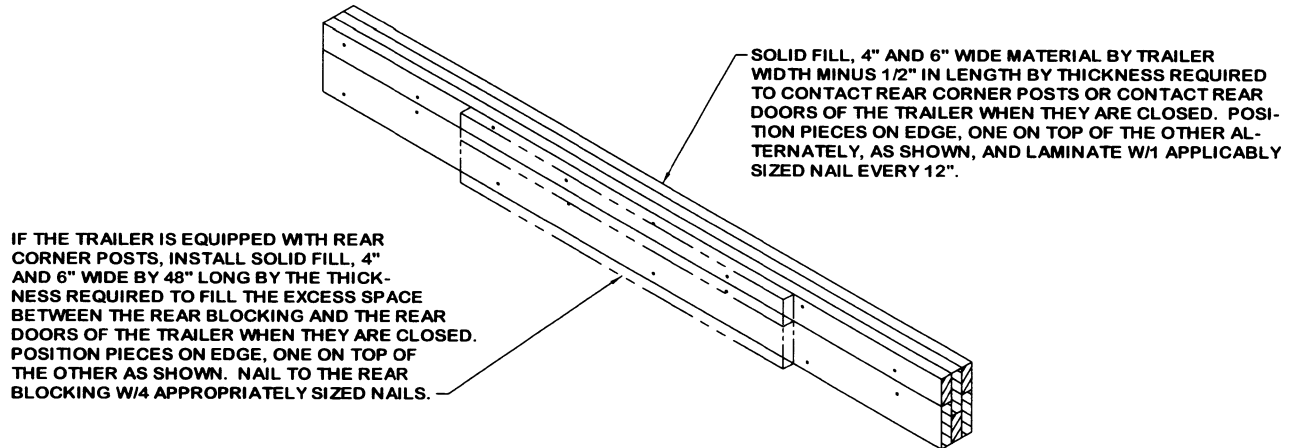

REAR BLOCKING ASSEMBLY B

THIS REAR BLOCKING ASSEMBLY IS DESIGNED FOR USE AT THE REAR OF A LOAD WHEN THE SPACE BETWEEN THE LADING AND THE TRAILER DOORS IS GREATER THAN 1-1/2" BUT LESS THAN 9".

STRUT, 2" X 6" BY CUT-TO-FIT (4 REQD).

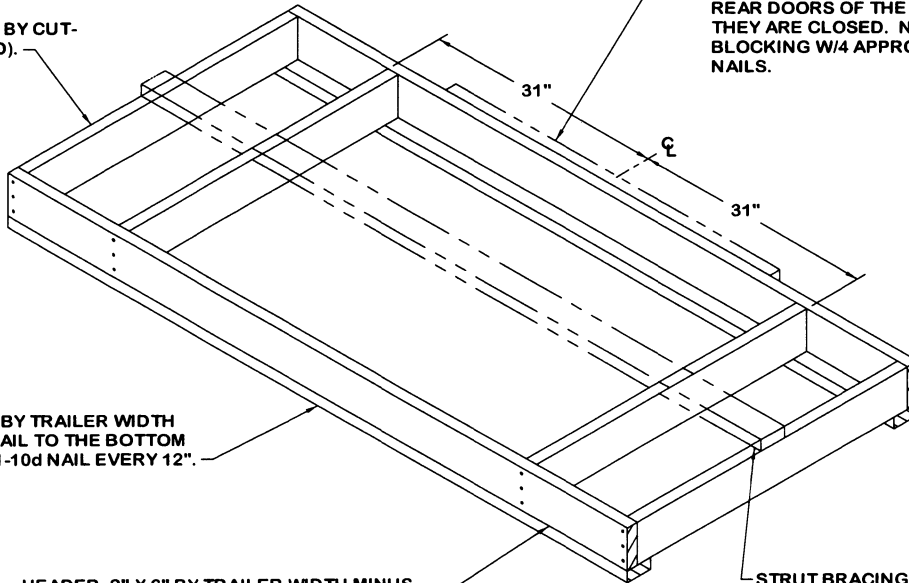

IF THE TRAILER IS EQUIPPED WITH REAR CORNER POSTS, INSTALL SOLID FILL, 6" WIDE BY 48" LONG BY THE THICKNESS REQUIRED TO FILL THE EXCESS SPACE BETWEEN THE REAR BLOCKING AND THE REAR DOORS OF THE TRAILER WHEN THEY ARE CLOSED. NAIL TO THE REAR BLOCKING W/4 APPROPRIATELY SIZED NAILS.

STRUT LEDGER, 2" X 4" BY TRAILER WIDTH MINUS 1/2" (2 REQD). NAIL TO THE BOTTOM EDGE OF A HEADER W/1-10d NAIL EVERY 12".

HEADER, 2" X 6" BY TRAILER WIDTH MINUS 1/2" IN LENGTH (2 REQD). NAIL TO THE STRUTS W/3-10d NAILS AT EACH JOINT.

STRUT BRACING, 2" X 4" BY TRAILER WIDTH MINUS 1/2" IN LENGTH (1 REQD FOR EVERY 7'-0" OF STRUT LENGTH FOR STRUTS LONGER THAN 7'-0"). NAIL TO THE STRUTS W/2-10d NAILS AT EACH JOINT.

REAR BLOCKING ASSEMBLY C

THIS ASSEMBLY IS DESIGNED FOR USE AT THE REAR OF A LOAD WHEN THE SPACE BETWEEN THE LADING AND THE TRAILER DOOR IS MORE THAN 9" AND ONE ROW OF PALLET UNITS IS LOADED ADJACENT TO THE TRAILER DOORS. NOTE THAT THE ABOVE VIEW IS ROTATED 180° FROM THE POSITION IN WHICH IT WILL BE INSTALLED.

SEE BELOW.

BUFFER, 2" X 6" X 7'-3-1/2" (2 REQD). NAIL TO THE STRUTS W/3-10d NAILS AT EACH JOINT.

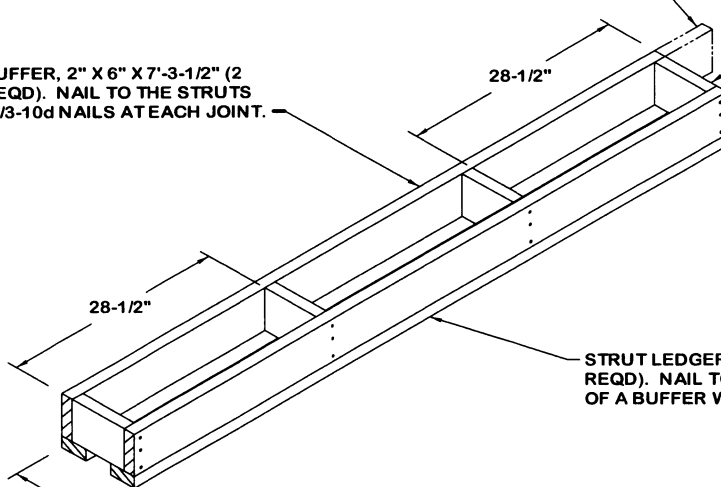

STRUT, 2" X 6" BY CUT-TO-FIT (4 REQD).

STRUT LEDGER, 2" X 4" X 7'-3-1/2" (2 REQD). NAIL TO THE BOTTOM EDGE OF A BUFFER W/7-10d NAILS.

FABRICATE TO FIT BETWEEN THE PALLET UNITS AND THE TRAILER SIDEWALL.

SIDE SPACER ASSEMBLY A

THIS ASSEMBLY IS THREE PALLET UNITS LONG. IF THE TRAILER BEING LOADED HAS ROUNDED CORNERS, AND THE ASSEMBLY IS TO BE USED ADJACENT TO THE FORWARD WALL, LENGTHEN ONE END OF ONE BUFFER PIECE BY 7", AS DEPICTED ABOVE.

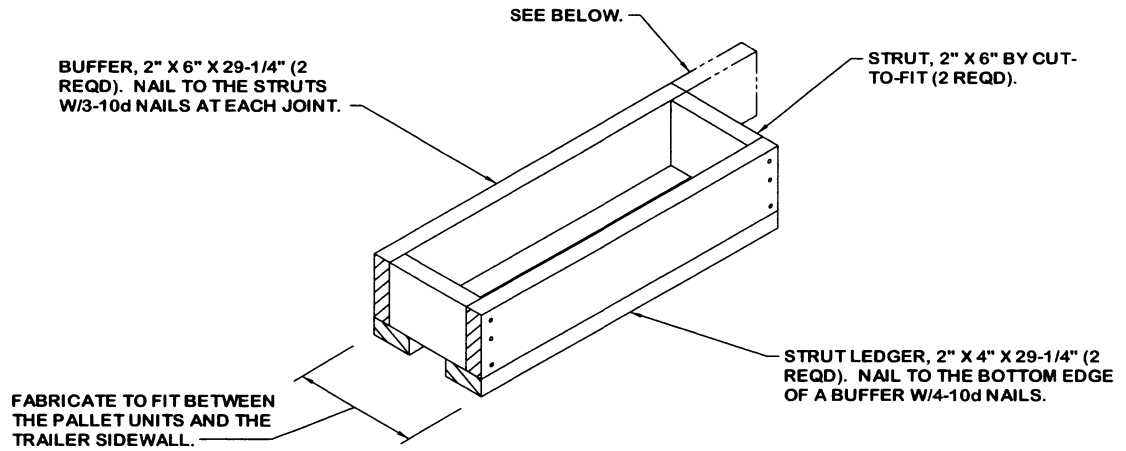

SIDE SPACER ASSEMBLY B

THIS ASSEMBLY IS ONE PALLET UNIT LONG. IF THE TRAILER BEING LOADED HAS ROUNDED CORNERS, AND THE ASSEMBLY IS TO BE USED ADJACENT TO THE FORWARD WALL, LENGTHEN ONE END OF ONE BUFFER PIECE BY 7", AS DEPICTED ABOVE.

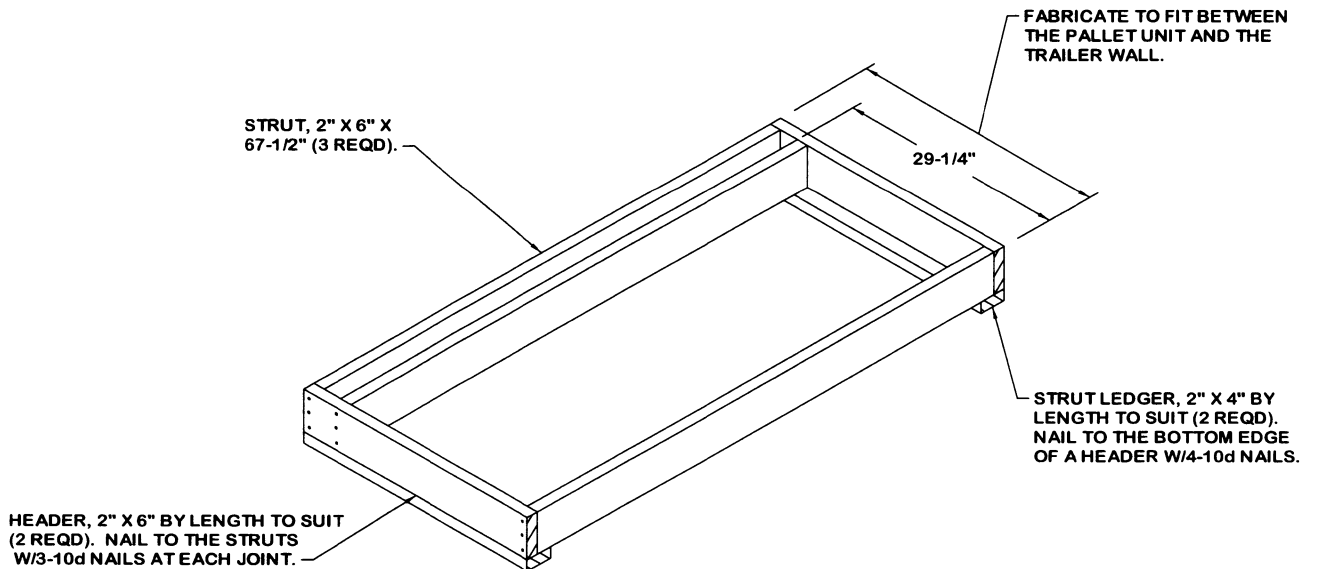

SPACER ASSEMBLY A

THIS ASSEMBLY IS DESIGNED TO REPLACE ONE PALLET UNIT.

STRUT, 2" X 6" BY CUT-TO-FIT (4 REQD).

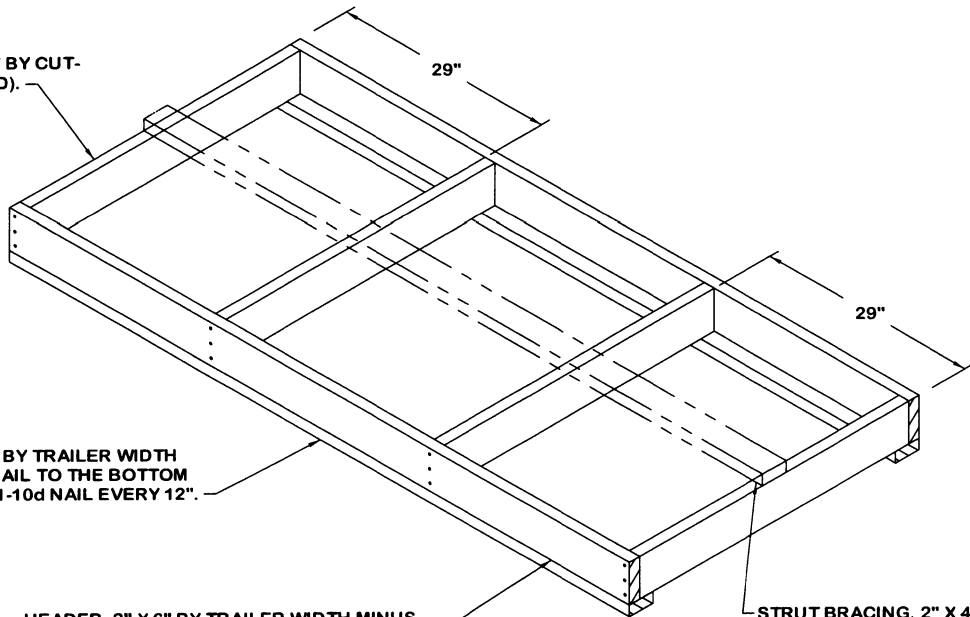

STRUT LEDGER, 2" X 4" BY TRAILER WIDTH MINUS 1/2" (2 REQD). NAIL TO THE BOTTOM EDGE OF A HEADER W/1-10d NAIL EVERY 12".

HEADER, 2" X 6" BY TRAILER WIDTH MINUS 1/2" IN LENGTH (2 REQD). NAIL TO THE STRUTS W/3-10d NAILS AT EACH JOINT.

STRUT BRACING, 2" X 4" BY TRAILER WIDTH MINUS 1/2" IN LENGTH (1 REQD FOR EVERY 7'-0" OF STRUT LENGTH FOR STRUTS LONGER THAN 7'-0"). NAIL TO THE STRUTS W/2-10d NAILS AT EACH JOINT.

SPACER ASSEMBLY B



ONE SEAL WITH TWO PAIR OF NOTCHES.

STRAP JOINT A

METHOD OF SECURING A STRAP JOINT WHEN USING A NOTCH-TYPE SEALER.



TWO SEALS, BUTTED TOGETHER, WITH TWO PAIR OF CRIMPS EACH SEAL.

STRAP JOINT B

METHOD OF SECURING A STRAP JOINT WHEN USING A CRIMP-TYPE SEALER.

END-OVER-END LAP JOINT DETAILS

SEAL FOR 1-1/4" STRAPPING
(2 REQD). CRIMP EACH SEAL
WITH TWO PAIR OF NOTCHES.

UNITIZING STRAP, 1-1/4" X .035"
OR .031" X 9'-0" LONG STEEL
STRAPPING (2 REQD).

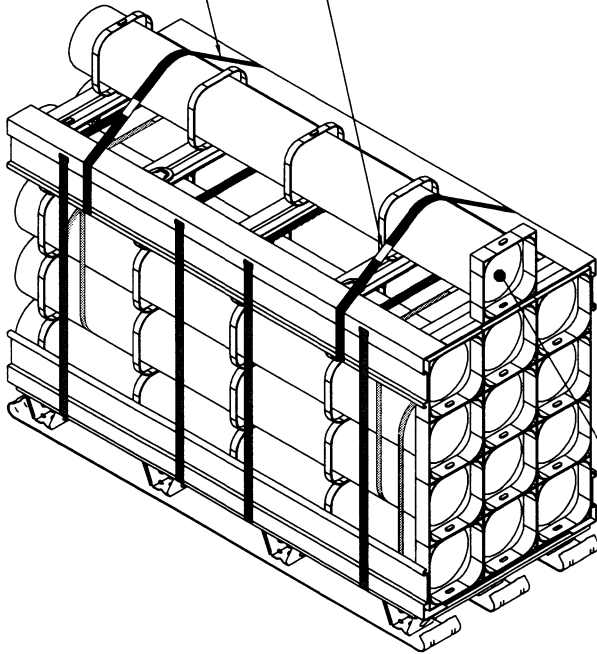

POSITION CONTAINER SO
AS TO BE CENTERED ON
THE LENGTH OF THE UNIT
AS NEAR AS PRACTICABLE.

SECUREMENT OF ONE CONTAINER

UNITIZING STRAP, 1-1/4" X .035"
OR .031" X 9'-6" LONG STEEL
STRAPPING (2 REQD).

SEAL FOR 1-1/4" STRAPPING
(2 REQD). CRIMP EACH SEAL
WITH TWO PAIR OF NOTCHES.

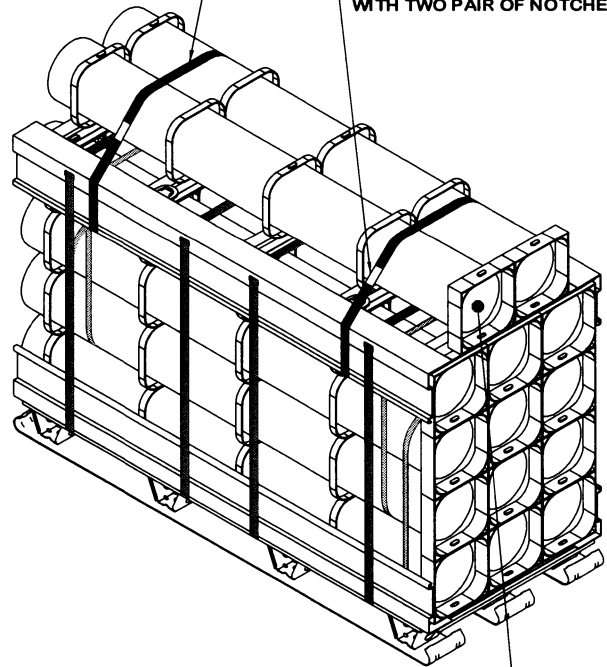

POSITION CONTAINERS SO
AS TO BE CENTERED ON
THE LENGTH OF THE UNIT
AS NEAR AS PRACTICABLE.

SECUREMENT OF TWO CONTAINERS

SPECIAL NOTES:

1. SHIPMENTS OF PALLET UNITS OF 2.75 INCH HYDRA ROCKETS SHOULD CONSIST OF FULL-HEIGHT UNITS TO THE MAXIMUM EXTENT POSSIBLE. HOWEVER, THE END OF A LOT OR THE QUANTITY OF ITEMS NEEDED TO FILL A REQUISITION MAY NECESSITATE THE SHIPMENT OF ONE OR MORE LEFTOVER CONTAINERS. LEFTOVER CONTAINERS ARE DESCRIBED AS ANY QUANTITY OF CONTAINERS BETWEEN ONE AND FIVE.
2. SHIPMENT OF LEFTOVER CONTAINERS IS APPLICABLE FOR CONUS AND OCONUS MOTOR CARRIER SHIPMENTS FROM DEPOT TO DEPOT OR FROM DEPOTS TO POSTS, CAMPS, AND STATIONS, OR, UPON APPROVAL FROM HIGHER HEADQUARTERS, FOR SHIPMENTS FROM LOAD, ASSEMBLE, AND PACK PLANTS TO DEPOTS. CAUTION: A LOAD CONTAINING LEFTOVER CONTAINERS IN AN AMOUNT WHICH IS LESS THAN A FULL LAYER, AND SECURED TO THE TOP OF A FULL OR PARTIAL UNIT, MUST NOT BE DESTINED FOR SHIPMENT OVERSEAS BY WATER CARRIER.
3. THE PROCEDURES ON THIS PAGE ARE PRESENTED AS GUIDANCE IN THE SECUREMENT OF LEFTOVER CONTAINERS FOR SHIPMENT. THE PROCEDURES ARE ALSO APPLICABLE FOR SECUREMENT OF LEFTOVER CONTAINERS TO PARTIAL PALLET UNITS FOR SHIPMENT ON TOP OF A LOAD. SEE SPECIAL NOTE 6 ON PAGE 26 FOR LIMITATIONS. IN ADDITION, THE PROCEDURES ARE APPLICABLE FOR SECURING LEFTOVER CONTAINERS TO A PARTIAL UNIT FOR SHIPMENT WITHIN A TIER.
4. THE PROCEDURES DEPICTED ON THIS PAGE ARE APPLICABLE FOR THE SHIPMENT OF LEFTOVER CONTAINERS IN ANY OF THE LOADS DEPICTED HEREIN.

UNITIZING STRAP, 1-1/4" X .035" OR .031" X 18'-0" LONG STEEL STRAPPING (2 REQD). INSTALL SO AS TO ENCIRCLE BOTH PALLETS. THREAD STRAPS THROUGH THE PALLET POSTS OF THE LOWER PALLET.

INDICATES A BUNDLING STRAP ON THE PARTIAL PALLET UNIT.

SEAL FOR 1-1/4" STRAPPING (2 REQD). CRIMP EACH SEAL WITH TWO PAIR OF NOTCHES.

INDICATES A TYPICAL 3-LAYER PARTIAL PALLET UNIT.

INDICATES A UNITIZING STRAP ON THE FULL PALLET UNIT.

INDICATES A TYPICAL PALLET UNIT AS SHOWN ON PAGE 3 OF THIS DRAWING.

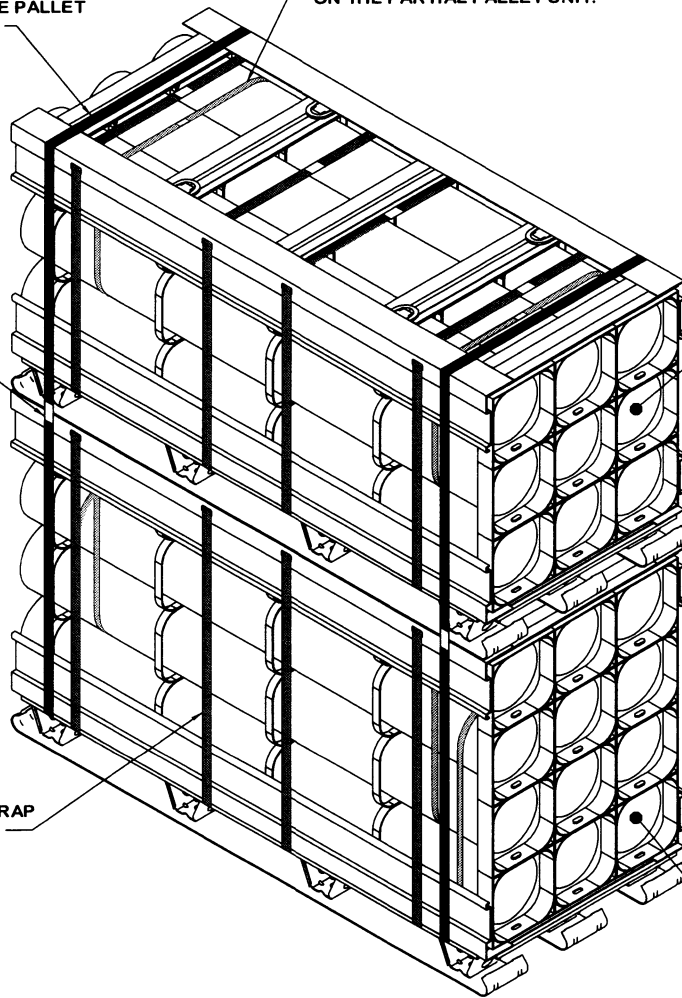

SECUREMENT OF A PARTIAL PALLET UNIT ON TOP OF A FULL PALLET UNIT

SPECIAL NOTES:

1. SHIPMENTS OF PALLET UNITS OF 2.75 INCH HYDRA ROCKETS SHOULD CONSIST OF FULL-HEIGHT AND FULL-LAYER UNITS TO THE MAXIMUM EXTENT POSSIBLE. HOWEVER, THE END OF A LOT OR THE QUANTITY OF ITEMS NEEDED TO FILL A REQUIREMENT MAY NECESSITATE THE SHIPMENT OF ONE OR MORE LESS-THAN-FULL PALLET UNITS WITHIN A LOAD. THE PROCEDURES ON THIS PAGE ARE PRESENTED AS GUIDANCE IN THE SHIPMENT OF THESE PARTIAL UNITS.
2. A PARTIAL PALLET UNIT MUST CONSIST OF EITHER TWO OR THREE FULL LAYERS IN ORDER FOR THE TOP AND BOTTOM PALLET ADAPTER ASSEMBLIES TO PROPERLY FUNCTION. A LAYER MAY CONSIST OF EMPTY CONTAINERS, THOUGH, AS DESCRIBED IN THE GENERAL NOTES OF AMC DRAWING 19-48-4231-20PM1006.
3. ELIMINATE THE TWO LOWER BUNDLING STRAPS WHEN UNITIZING A THREE-HIGH PARTIAL PALLET, AND ELIMINATE ALL FOUR BUNDLING STRAPS WHEN UNITIZING A TWO-HIGH PARTIAL PALLET UNIT.

(SPECIAL NOTES CONTINUED AT RIGHT)

SPECIAL NOTES (CONT.)

4. A LESS-THAN-FULL HEIGHT PALLET UNIT CAN BE SHIPPED BY POSITIONING IT EITHER ON THE TOP TIER OF A LOAD OR ON THE TOP OF A LOWER PORTION OF A LOAD WHEN THE LOAD CONTAINS A PARTIAL TIER IN THE END OF THE TRAILER. THE PARTIAL UNIT WILL BE STRAPPED TO THE PALLET UNIT DIRECTLY BELOW WITH TWO VERTICAL UNITIZING STRAPS. SEE THE "SECUREMENT OF A PARTIAL UNIT ON TOP OF A FULL PALLET UNIT" VIEW ABOVE FOR GUIDANCE.
5. A PARTIAL PALLET UNIT MUST NOT BE POSITIONED ON THE REARMOST PALLET UNIT IN THE LOAD.
6. LEFTOVER CONTAINERS, IN AN AMOUNT WHICH IS LESS THAN THE QUANTITY IN ONE LAYER OF A UNIT, CAN BE SECURED TO THE TOP OF A PARTIAL UNIT FOR SECUREMENT ON TOP OF A LOAD. THE LEFTOVER CONTAINERS MUST BE SECURED TO THE PARTIAL UNIT WITH THEIR OWN STRAPPING, SEPARATE FROM THE STRAPS FOR THE PARTIAL UNIT. SEE THE DETAILS ON PAGE 25 FOR GUIDANCE IN STRAP APPLICATION.

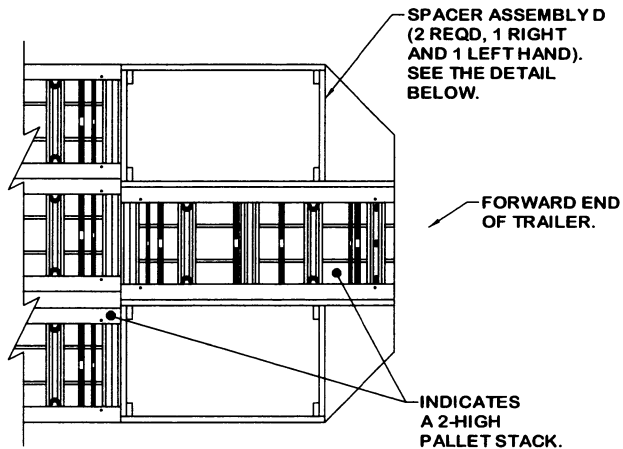
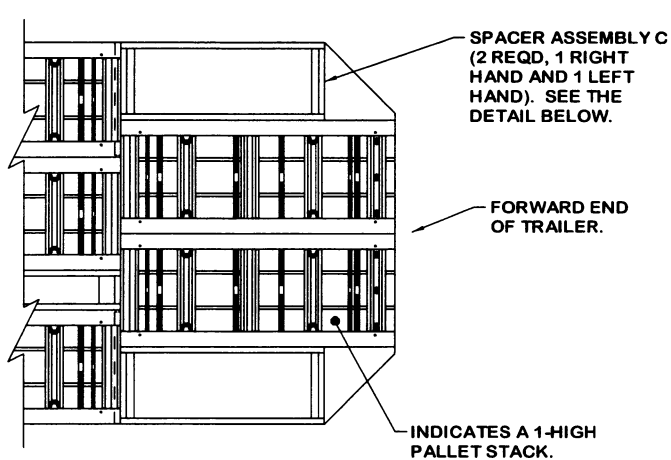

ALTERNATIVE FORWARD LOADING PATTERN A

THIS PROCEDURE IS APPLICABLE TO THE LOADING OF TWO PALLET UNITS (2-WIDE, 1-HIGH) IN THE FORWARD END OF A VAN TRAILER HAVING LARGE-ANGLED FRONT CORNERS (REF: 18"). THE PROCEDURES MAY ALSO BE USED IN TRAILERS HAVING SQUARE CORNERS, OR ROUNDED FRONT CORNERS, OR ANGLED CORNERS OF ANOTHER SIZE. A 98" WIDE TRAILER IS SHOWN, NARROW TRAILERS CAN BE USED, AND ONE PALLET UNIT MAY LOADED IN THE FORWARD END OF THE TRAILER IN PLACE OF TWO.

ALTERNATIVE FORWARD LOADING PATTERN B

THIS PROCEDURE IS APPLICABLE TO THE LOADING OF A STACK OF TWO (1-WIDE, 2-HIGH) PALLET UNITS IN THE FORWARD END OF A VAN TRAILER HAVING LARGE-ANGLED FRONT CORNERS (REF: 18"). THE PROCEDURES MAY ALSO BE USED IN TRAILERS HAVING SQUARE CORNERS, OR ROUNDED FRONT CORNERS, OR ANGLED CORNERS OF ANOTHER SIZE. NOTE THAT IF THE LOAD UNIT BEHIND THE STACKED PALLET UNITS IN THE FRONT IS ONLY ONE HIGH, TWO UNITIZING STRAPS MUST BE INSTALLED AROUND THOSE PALLET UNITS IN THE FRONT STACK.

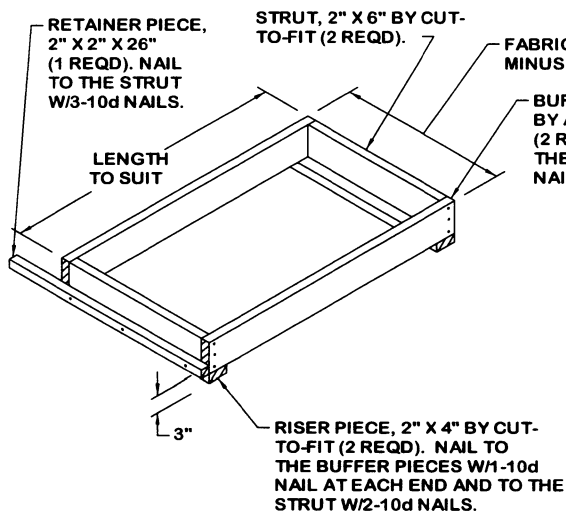

SPACER ASSEMBLY C

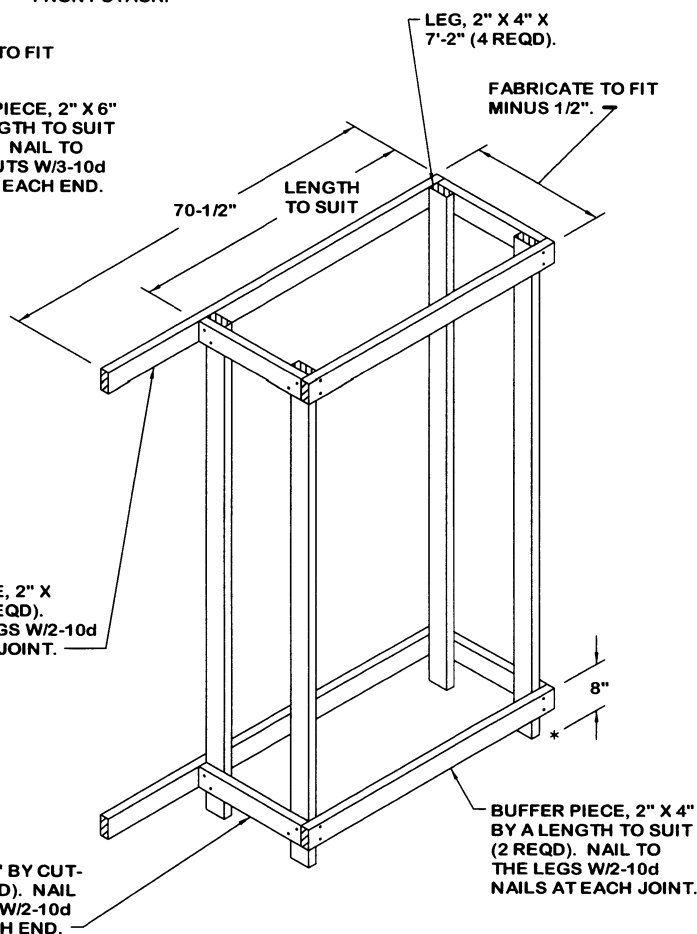

SPACER ASSEMBLY D

THIS ASSEMBLY IS DESIGNED FOR LATERAL BRACING OF A 2-HIGH PALLET STACK LOCATED IN THE FRONT OF AN ANGLED-CORNER CONVENTIONAL VAN TRAILER AS SHOWN IN THE "ALTERNATIVE FORWARD LOADING PATTERN B" VIEW ABOVE. NOTE THAT THIS VIEW DEPICTS THE ASSEMBLY POSITIONED 180° FROM THE POSITION IN WHICH IT WILL BE INSTALLED IN A LOAD. RIGHT HAND AND LEFT HAND SPACER ASSEMBLIES ARE REQUIRED.

