

VOLCANO

UNITIZATION PROCEDURES FOR VOLCANO MINE SYSTEM HARDWARE, LAUNCHER ASSEMBLY, PACKED IN FIBERGLASS REINFORCED PLASTIC CONTAINERS

DISTRIBUTION STATEMENT A.

APPROVED FOR PUBLIC RELEASE:
DISTRIBUTION IS UNLIMITED.

U.S. ARMY MATERIEL COMMAND DRAWING					
APPROVED, U.S. ARMY INDUSTRIAL OPERATIONS COMMAND <i>NH</i> <i>David A. P. Schenk</i> AMSTA-AR-ESK	DRAFTSMAN ENGINEER BETTY J. KUNDERT SANDRA M. SCHULTZ				
<i>David A. P. Schenk</i> AMSTA-AR-ESK	<i>David E. Stachurski</i> AMSIO-TMJ	SUPPLY ENGINEERING DIVISION <i>T. J. Mullen</i>	TRANSPORTATION ENGINEERING DIVISION <i>W. Eric</i>	VALIDATION ENGINEERING DIVISION <i>W. Eric</i>	
APPROVED BY ORDER OF COMMANDING GENERAL, U.S. ARMY MATERIEL COMMAND <i>James W. Kelly</i>		LOGISTICS ENGINEERING OFFICE <i>William F. Ernst</i>			
U.S. ARMY DEFENSE AMMUNITION CENTER AND SCHOOL		SEPTEMBER 1988			
REVISION NO. 3	MARCH 1996	CLASS	DIVISION	DRAWING	FILE
SEE THE REVISION LISTING ON PAGE 2		19	48	4240/1	20PM 1009

DO NOT SCALE

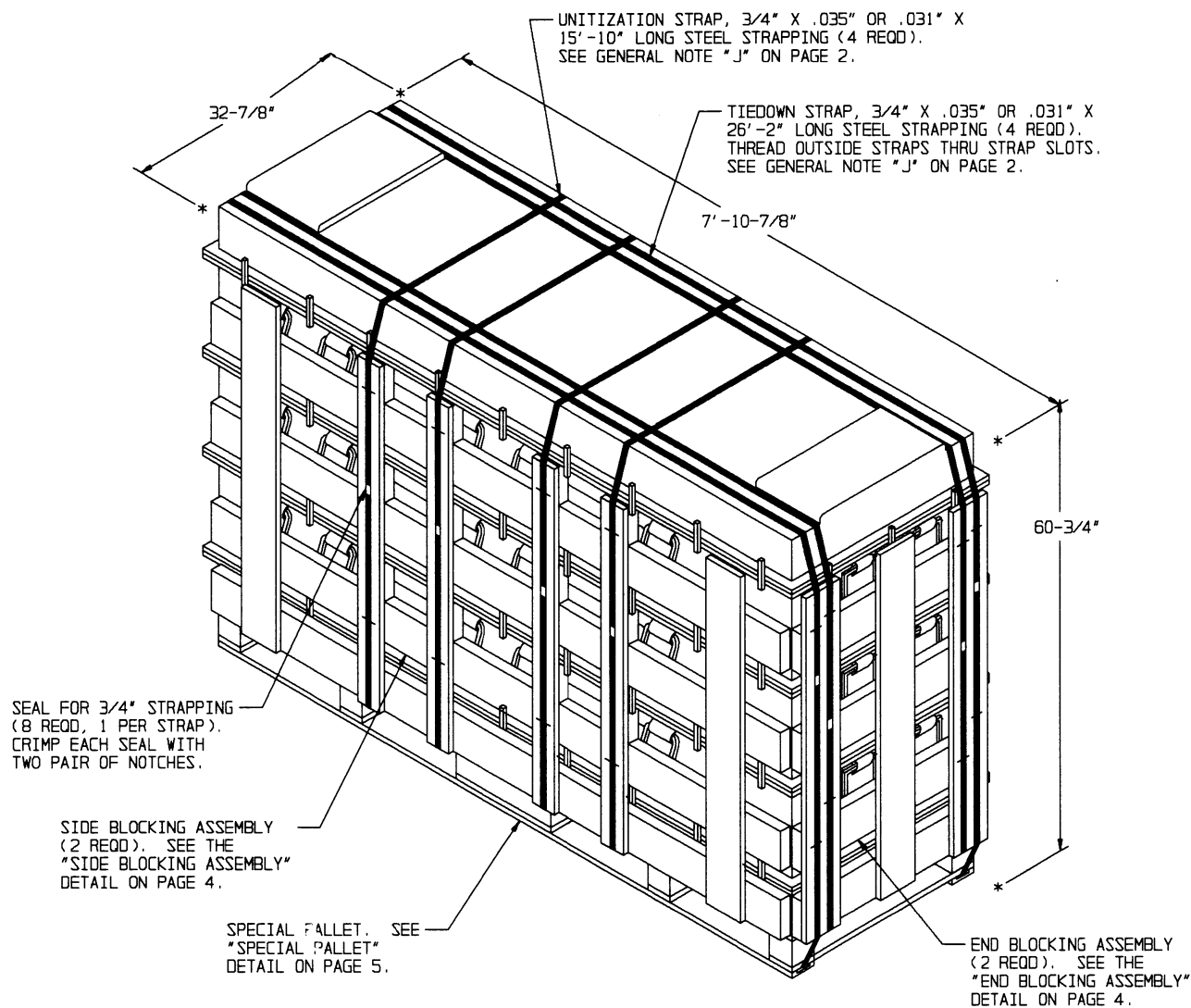

UNIT LOAD

4 CONTAINERS OF LAUNCHER RACK @ 512 LBS	-----	2,048 LBS
DUNNAGE	-----	322 LBS
TOTAL WEIGHT	-----	2,370 LBS
CUBE	-----	109.7 CU FT

BILL OF MATERIAL

LUMBER	LINEAR FEET	BOARD FEET / LBS
1" X 4"	83.57	27.85 / 55.70
1" X 6"	15.73	7.87 / 15.74
2" X 4"	14.00	9.33 / 18.66
2" X 6"	79.42	79.42 / 158.84
4" X 4"	4.83	6.44 / 12.88
NAILS	NO. REQD	POUNDS
6d (2")	312	1.84
8d (2-1/2")	34	0.36
10d (3")	34	0.52
PLYWOOD, 3/4"	20.34 SQ FT REQD	41.96 LBS
STEEL STRAPPING, 3/4"	168.00' REQD	15.00 LBS
SEAL FOR 3/4" STRAPPING	8 REQD	NIL
STAPLE, 15/16" X 3/4"	32 REQD	NIL
ANTI-CHAFING MATERIAL	AS REQD	NIL

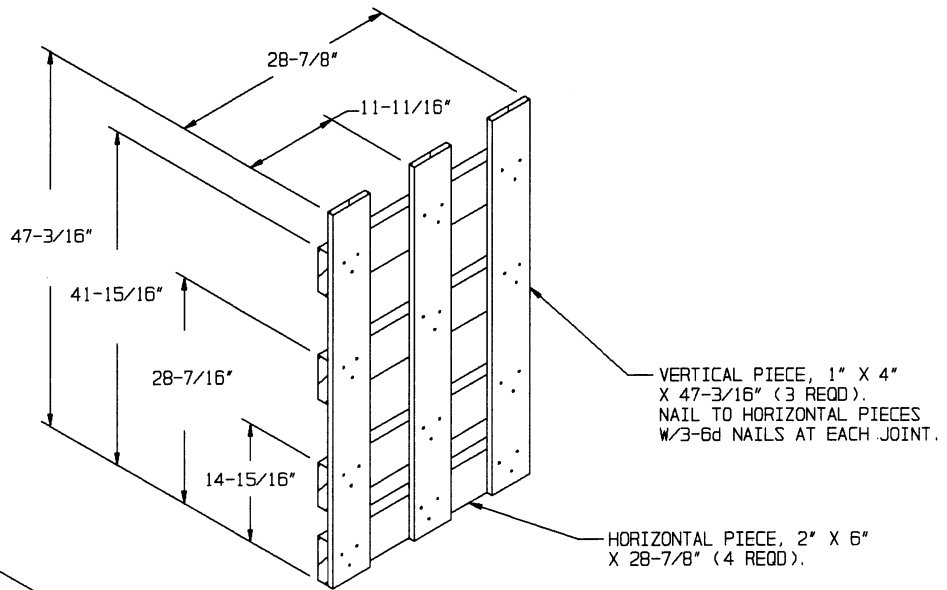

END BLOCKING ASSEMBLY

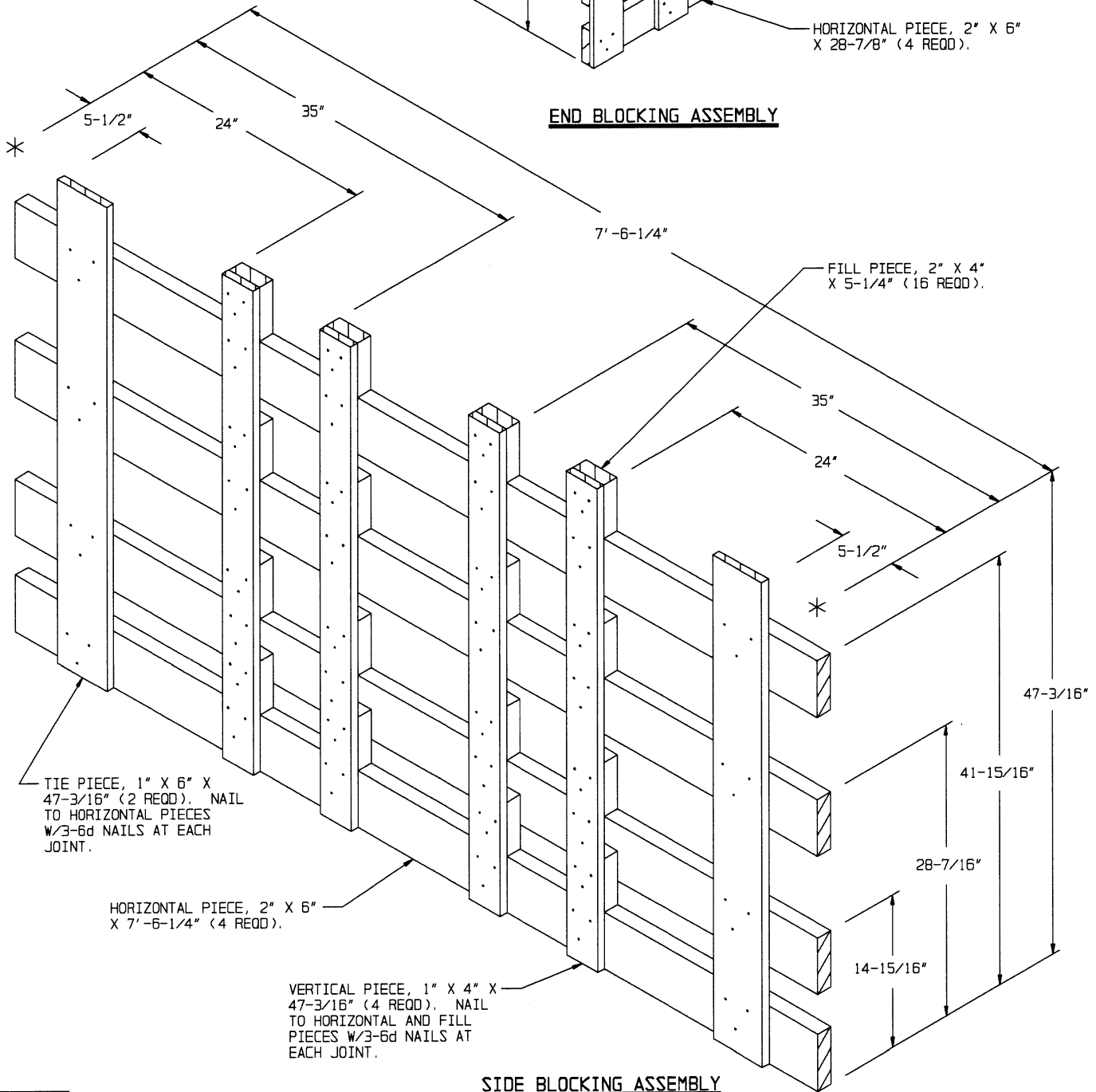

SIDE BLOCKING ASSEMBLY

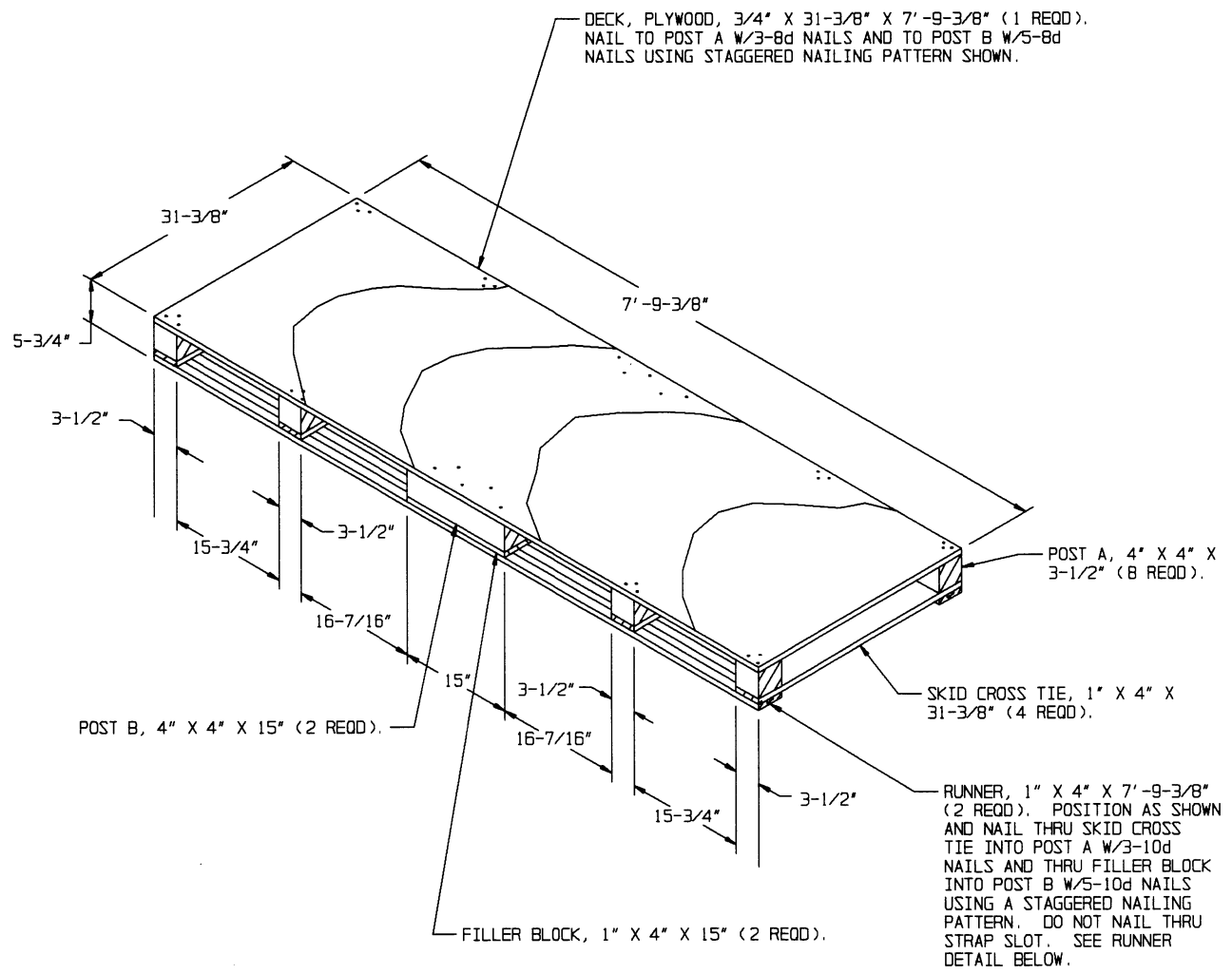

SPECIAL PALLET

