

UNITIZATION PROCEDURES FOR ARMOR TILE, M7 SERIES, PACKED 4 PER WOODEN BOX, UNITIZED 10 BOXES PER 35" X 45-1/2" PALLET; APPROX BOX SIZE 36-1/4" L X 9-7/8" W X 14-3/4" H

DISTRIBUTION STATEMENT A:

APPROVED FOR PUBLIC RELEASE;
DISTRIBUTION IS UNLIMITED.

U.S. ARMY MATERIEL COMMAND DRAWING

<p>APPROVED, U.S. ARMY RESEARCH, DEVELOPMENT AND ENGINEERING COMMAND <i>Travis</i></p> <p style="text-align: center;"><i>David A. Redmond</i> AMSRD-AAR-AIL-TP</p>	<p>CAUTION: VERIFY PRIOR TO USE AT WWW.DAC.ARMY.MIL THAT THIS IS THE MOST CURRENT VERSION OF THIS DOCUMENT. THIS IS PAGE 1 OF 4.</p>												
<p>APPROVED, U.S. ARMY JOINT MUNITIONS COMMAND</p> <p style="text-align: center;"><i>[Signature]</i> AMSJM-LIT</p>	<p>DO NOT SCALE</p>		<p>AUGUST 1987</p>										
<p>*APPROVED BY ORDER OF COMMANDING GENERAL, U.S. ARMY MATERIAL COMMAND</p> <p style="text-align: center;"><i>Charles R. Stro</i></p> <p>U.S. ARMY DEFENSE AMMUNITION CENTER</p>	<p>TRANSPORTATION ENGINEERING DIVISION</p> <p>VALIDATION ENGINEERING DIVISION</p> <p>ENGINEERING DIRECTORATE</p>	<p>BASIC REV. <i>[Signature]</i></p> <p>LAURA FIEFFER</p> <p>PATRICK DOUGHERTY</p> <p><i>[Signature]</i></p> <p><i>[Signature]</i> TESTED</p> <p><i>[Signature]</i></p>	<table border="1" style="width: 100%; border-collapse: collapse;"> <tr> <td style="text-align: center;">REVISION NO. 3</td> <td style="text-align: center;">NOVEMBER 2006</td> </tr> <tr> <td style="text-align: center;">CLASS</td> <td style="text-align: center;">DIVISION</td> <td style="text-align: center;">DRAWING</td> <td style="text-align: center;">FILE</td> </tr> <tr> <td style="text-align: center;">19</td> <td style="text-align: center;">48</td> <td style="text-align: center;">4221/6</td> <td style="text-align: center;">20PA1009</td> </tr> </table>	REVISION NO. 3	NOVEMBER 2006	CLASS	DIVISION	DRAWING	FILE	19	48	4221/6	20PA1009
REVISION NO. 3	NOVEMBER 2006												
CLASS	DIVISION	DRAWING	FILE										
19	48	4221/6	20PA1009										

PALLET UNIT DATA				
ITEMS INCLUDED		*HAZARD CLASS AND DIVISION	*COMPATIBILITY GROUP	APPROX WEIGHT (LBS)
NSN	DODIC			
1375-				
01-257-3985	ML99	1.4	D	1,303
01-410-7417	ML99	1.4	D	1,353
01-530-5633	ML99	1.2.3	D	1,353

*HAZARD AND CLASSIFICATION DATA CONTAINED IN THE ABOVE CHART IS FOR GUIDANCE AND INFORMATIONAL PURPOSES ONLY. VERIFICATION OF THE SPECIFIED DATA SHOULD BE MADE BY CONSULTING THE MOST RECENT JOINT HAZARD CLASSIFICATION SYSTEM LISTING OR OTHER APPROVED LISTING(S).

REVISIONS

REVISION NO. 1, DATED OCTOBER 1987, CONSISTS OF:

ADDING GENERAL NOTE (STYLE 1A PALLET).

REVISION NO. 2, DATED MARCH 1996, CONSISTS OF:

1. CHANGING THE TITLE FROM XM7 TO M7.
2. CHANGING THE DATA ON "PALLET UNIT DATA" CHART.
3. DELETING GENERAL NOTE RELATING TO STRAP CUTTER AND RE-LETTERING OTHER GENERAL NOTES.

REVISION NO. 3, DATED NOVEMBER 2006, CONSISTS OF:

1. CHANGING THE TITLE FROM M7 TO M7 SERIES.
2. ADDING ITEM BY NATIONAL STOCK NUMBER (NSN) TO "PALLET UNIT DATA CHART".
3. UPDATING STRAPPING SPECIFICATION TO ALLOW .029" THICKNESS.
4. UPDATING DRAWING FORMAT.

GENERAL NOTES

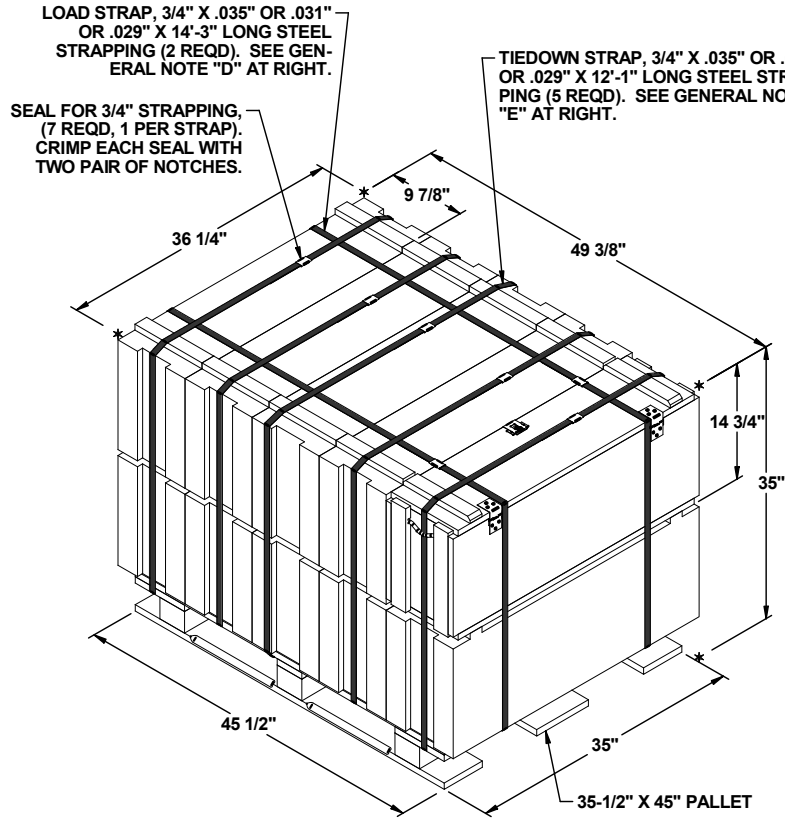

PALLET UNIT

SEE GENERAL NOTE "B" AT RIGHT.

10 BOXES OF ARMOR TILES (4 PER BOX) @ 128 LBS	-----	1,280 LBS
DUNNAGE	-----	8 LBS
PALLET	-----	65 LBS
TOTAL WEIGHT		1,353 LBS (APPROX)
CUBE		36.3 CU FT (APPROX)

BILL OF MATERIAL

PALLET, 35" X 45-1/2"	-----	1 REQD	-----	65 LBS
STEEL STRAPPING, 3/4"	-----	88.92' REQD	-----	7.94 LBS
SEAL FOR 3/4" STRAPPING	-----	7 REQD	-----	NIL

- A. THIS DOCUMENT HAS BEEN PREPARED AND ISSUED IN ACCORDANCE WITH AR 740-1, AND AUGMENTS TM 743-200-1 (CHAPTER 5) AND CONFORMS TO MIL-STD-1660.
- B. DIMENSIONS, CUBE AND WEIGHT OF A PALLET UNIT WILL VARY SLIGHTLY DEPENDING UPON THE ACTUAL DIMENSIONS OF THE BOXES AND THE WEIGHT OF THE SPECIFIC ITEM BEING UNITIZED.
- C. FOR DETAILS OF THE MIL-B-2427 BOX SEE ARDEC DRAWING 12590323.
- D. THE LOAD STRAPS MAY BE THREADED THROUGH THE STRAP SLOTS OF A PALLET OR PRE-POSITIONED ON THE PALLET DECK PRIOR TO PLACING THE BOXES ON THE PALLET. LOAD STRAPS MUST BE TENSIONED AND SEALED PRIOR TO APPLICATION OF TIEDOWN STRAPS.
- E. INSTALL EACH TIEDOWN STRAP TO PASS UNDER THE DECK/STRINGER BOARDS OF THE PALLET AND TO BE LOCATED AS SHOWN. TIEDOWN STRAPS ALSO MAY BE THREADED THROUGH THE ROPE HANDLES OF THE BOXES TO PREVENT DAMAGE TO THE HANDLES. TIEDOWN STRAPS WILL NOT BE APPLIED UNTIL THE LOAD STRAPS HAVE BEEN TENSIONED AND SEALED.
- F. THE FOLLOWING AMC DRAWINGS ARE APPLICABLE FOR UNLOADING AND STORAGE OF THE ITEMS COVERED BY THIS APPENDIX.

CARLOADING	-----	19-48-4115-5PA1002
TRUCKLOADING	-----	19-48-4117-11PA1003
STORAGE	-----	19-48-4118-1-2-3-4-14-22PA1002
END OPENING ISO CONTAINER	-----	19-48-4153-15PA1002
MILVAN	-----	19-48-4166-15PA1003
SIDE OPENING ISO CONTAINER	-----	19-48-4267-15PA1009
- G. IF ITEMS COVERED HEREIN ARE UNITIZED PRIOR TO ISSUANCE OF THIS REVISION TO THIS DRAWING, THE CONTAINERS NEED NOT BE REUNITIZED SOLELY TO CONFORM TO THIS REVISION..
- H. THE STYLE 1A PALLET DELINEATED IN THE DETAIL AT LEFT NEED NOT HAVE CHAMFERS OR STRAP SLOTS AS SPECIFIED WITHIN MILITARY SPECIFICATION MIL-P-15011 WHEN USED FOR THE UNITIZATION OF ITEMS COVERED BY THIS APPENDIX.
- J. WHEN APPLYING ANY STRAP, CARE MUST BE EXERCISED TO ASSURE THAT THE END OF THE STRAP ON THE UNDERSIDE OF THE JOINT EXTENDS AT LEAST 6" BEYOND THE SEAL. THIS EXTRA MINIMUM LENGTH OF STRAP IS REQUIRED TO PERMIT SUBSEQUENT TIGHTENING OF LOOSENED STRAPPING. RETENSIONING CAN BE ACCOMPLISHED WITH OUT REPLACING STRAPPING OR SPLICING STRAPPING THROUGH THE USE OF A MANUAL OR PNEUMATIC FEEDWHEEL TYPE TENSIONING TOOL AND THE APPLICATION OF ONE ADDITIONAL SEAL.
- K. IN ORDER TO OBTAIN COMPACT (SOUND) UNITS, ALL STRAPS SHALL BE LOCATED IN PROPER ALIGNMENT AND TENSIONED UNTIL THE CUT INTO THE EDGE OF THE PALLET DECK. AFTER TENSIONING, ALL STRAPS WILL BE SECURED USING ONE SEAL AND TWO PAIR OF NOTCHES.
- L. A PLUS OR MINUS 1/4" IS ALLOWED ON OVERALL DIMENSIONS OF ANY DUNNAGE ASSEMBLY. HOWEVER, SIMILAR PIECES IN AN ASSEMBLY MUST BE WITHIN 1/8" OF THE SAME DIMENSION.
- M. DIMENSIONAL LUMBER SPECIFIED THROUGHOUT THIS PROCEDURAL DRAWING IS OF A NOMINAL SIZE UNLESS OTHERWISE SPECIFIED, FOR EXAMPLE, 1" X 4" MATERIAL IS ACTUALLY 3/4" THICK BY 3-1/2" WIDE.
- N. COOLER NAILS MAY BE SUBSTITUTED FOR THE COMMON NAILS AS SPECIFIED BY APPLYING THE FOLLOWING GUIDANCE: THE NUMBER OF COOLER NAILS TO BE USED WILL BE THE NUMBER OF COMMON NAILS MULTIPLIED BY 1.2 AND ROUNDED UP TO THE NEXT WHOLE NUMBER. THE SIZE OF THE COOLER NAILS TO BE USED WILL BE THE SAME AS SPECIFIED FOR THE COMMON NAILS (4d, 6d, 10d, ETC.) BUT WILL CONFORM TO THE SIZE AND WEIGHT TOLERANCE SPECIFIED WITHIN ASTM F1667 FOR COOLER NAILS.
- O. UNIT LOAD MARKINGS WILL BE ACCOMPLISHED IN ACCORDANCE WITH DAC DRAWING ACV00561, UNIT LOAD MARKING FOR SHIPMENT AND STORAGE, AMMUNITION AND EXPLOSIVES.

(CONTINUED ON PAGE 4)

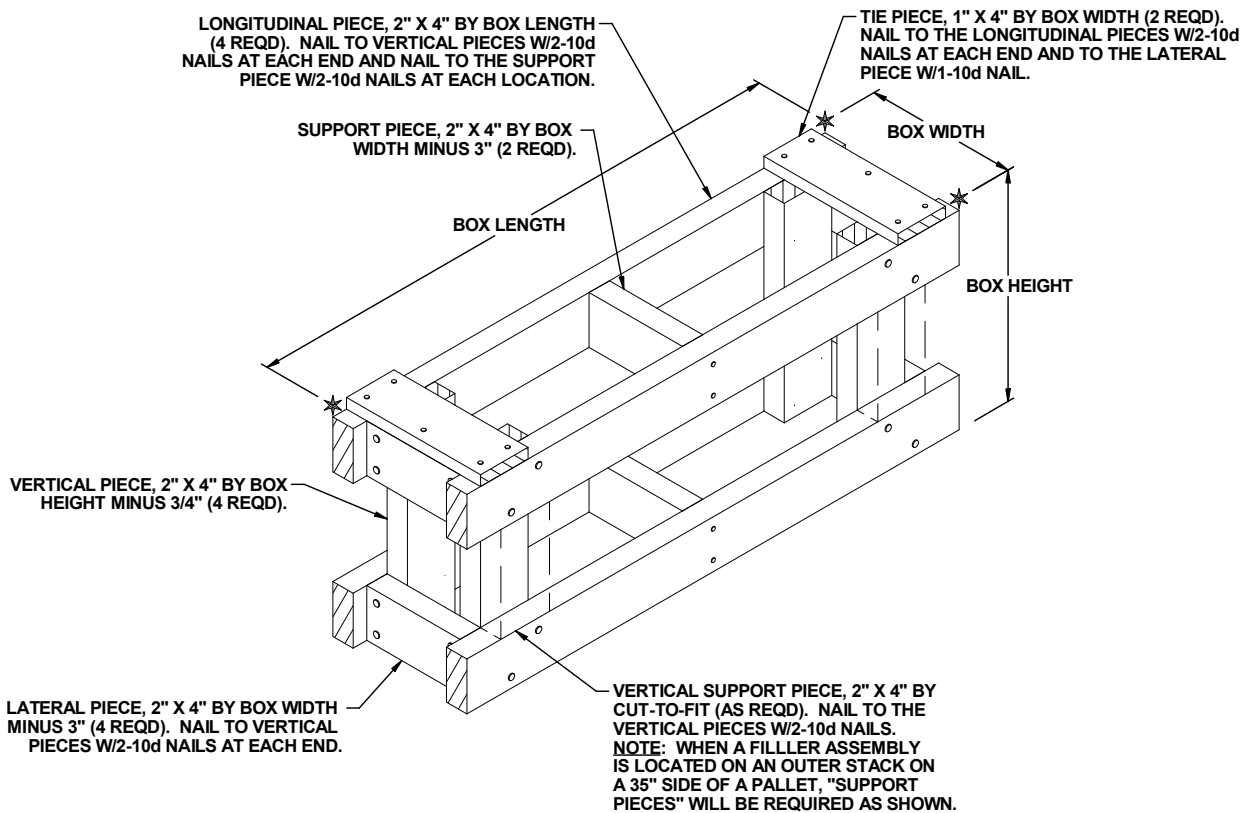

FILLER ASSEMBLY
(FOR MINUS ONE BOX)

(GENERAL NOTES CONTINUED FROM PAGE 3)

- P. DIMENSIONS GIVEN FOR DUNNAGE ASSEMBLIES WILL BE FIELD CHECKED PRIOR TO THEIR ASSEMBLY. THIS GUIDANCE MUST BE APPLIED PRIOR TO BEGINNING A PALLETIZATION OPERATION. ALSO, DUE TO VARIATIONS OF PACKAGE DIMENSIONS, ADJUSTMENTS MAY BE REQUIRED AS TO THE LOCATION OF CERTAIN PIECES ON DUNNAGE ASSEMBLIES. THESE ASSEMBLIES SHALL NOT PROTRUDE PAST THE TOP AND/OR SIDES OF THE BOXES.
- Q. ALL WOODEN DUNNAGE AND PALLETS MUST BE PRESERVATIVE TREATED IN ACCORDANCE WITH THE PROCEDURES SPECIFIED IN MIL-B-2427 FOR CLEATED WOODEN BOXES. IF THE DUNNAGE CONSISTS OF MORE THAN ONE COMPONENT, IT MUST BE ASSEMBLED PRIOR TO TREATMENT. THE LETTERS PA DENOTING PQ56 (COPPER-8-QUINOLINOLATE), PB DENOTING M-GARD W550 (ZINC NAPHTHANATE EMULSIFIABLE) OR PC DENOTING M-GARD W510 OR CUNAPOL 5 (COPPER NAPHTHANATE) MUST BE APPLIED TO THE WOOD DUNNAGE IN LETTERS AT LEAST ONE-INCH HIGH.
- R. ALL NON-MANUFACTURED WOOD USED IN THE PALLETIZED LOAD SHALL BE HEAT TREATED TO A CORE TEMPERATURE OF 56 DEGREES CELSIUS FOR A MINIMUM OF 30 MINUTES. THE PALLET MANUFACTURER AND THE MANUFACTURER OF WOOD TO BUILD FILLER ASSEMBLIES AND DUNNAGE ASSEMBLIES FOR THE PALLETIZED LOAD SHALL BE AFFILIATED WITH AN INSPECTION AGENCY ACCREDITED BY THE U.S. DEPARTMENT OF AGRICULTURE. THE PALLET MANUFACTURER AND THE MANUFACTURER OF WOOD USED TO BUILD FILLER ASSEMBLIES AND DUNNAGE ASSEMBLIES FOR THE PALLETIZED LOAD SHALL ENSURE TRACEABILITY TO THE ORIGINAL SOURCE OF HEAT TREATMENT. EACH PALLET, FILLER ASSEMBLY, OR DUNNAGE ASSEMBLY SHALL BE MARKED TO SHOW THE CONFORMANCE TO THE INTERNATIONAL PLANT PROTECTION CONVENTION STANDARD. PALLETS, FILLER ASSEMBLIES, AND DUNNAGE ASSEMBLIES MADE OF NON-MANUFACTURED WOOD SHALL BE HEAT TREATED AND MARKED APPROPRIATELY. THE QUALITY MARK FOR THE PALLET SHALL BE PLACED ON TWO OPPOSITE END POST ON THE SAME SIDE AS THE PRESERVATIVE MARKING. THE QUALITY MARK FOR THE FILLER ASSEMBLIES AND DUNNAGE ASSEMBLIES SHALL BE PLACED ON TWO OPPOSITE SIDES.

MATERIAL SPECIFICATIONS

- LUMBER** - - - - - : SEE TM 743-200-1 (DUNNAGE LUMBER) AND VOLUNTARY PRODUCT STANDARD PS 20 FOR FILLER ASSEMBLIES. ASTM D 6199; CLASS 2, GROUP II, III, OR IV, PRESERVATIVE AND HEAT TREATED FOR OTHER DUNNAGE ASSEMBLIES. **NOTE:** ONLY GROUP IV LUMBER IN ACCORDANCE WITH ASTM D 6199 WILL BE ACCEPTABLE FOR THE CONSTRUCTION OF THE PALLET.
- PALLET** - - - - - : MIL SPEC MIL-P-15011; 4-WAY ENTRY, STYLE 1A, TYPE I, CLASS 1, PRESERVATIVE AND HEAT TREATED
- NAILS** - - - - - : ASTM F1667; COMMON STEEL NAIL (NLCMS OR NLCMMS). ALT: UNDERLAYMENT NAIL (NLUL), PALLET NAIL (NLPL), OR COOLER NAIL (NLCL) OF SAME SIZE.
- STRAPPING, STEEL** - - : ASTM D3953; FLAT STRAPPING, TYPE 1, HEAVY DUTY, FINISH B (GRADE 2), SIZE 3/4" X .035" OR .031" OR .029". ALTERNATIVE SIZE 1-1/4" X 0.35" OR .031" OR .029". **NOTE:** IF EDGES DO NOT MEET THE PREECE TEST FOR GRADE 2, ANY BRITTE OR SLIT EDGES MUST HAVE FINISH A OVERLAY APPLIED.
- SEAL, STRAP** - - - - : ASTM D3953; CLASS H, FINISH B (GRADE 2), DOUBLE NOTCH TYPE, STYLE I, II, III, OR IV. ALTERNATIVE SEAL FINISH: SIGNODE OR DELTA PAINTED SEALS MAY BE USED AS AN ALTERNATIVE IF ALL SURFACES ARE PAINTED. GRITTED BACKING IS NOT PERMITTED.