

# UNITIZATION PROCEDURES FOR ABRAMS ARMOR TILE SPARE PARTS ON 4-WAY ENTRY PALLETS

**ARBAMS REACTIVE ARMOR TILE II (ARAT II), XM32,  
PACKED ONE PER WOODEN BOX, UNITIZED 20  
BOXES PER 35" X 45-1/2" PALLET; APPROX BOX  
SIZE 24-5/8" L X 18-7/8" W X 8-3/16" H**

**DISTRIBUTION STATEMENT A:**

APPROVED FOR PUBLIC RELEASE  
DISTRIBUTION IS UNLIMITED.

## U.S. ARMY MATERIEL COMMAND DRAWING

<b>APPROVED, U.S. ARMY RESEARCH, DEVELOPMENT AND ENGINEERING COMMAND</b> <b>PISKORIK.DAVID.</b> A.1229069167 <small>Digitally signed by PISKORIK.DAVID. A.1229069167 DN: cn=PISKORIK.DAVID.A.1229069167, c=US, o=U.S. Government, ou=DoD, PKI, USA Date: 2008.03.03 15:14:48 -0500</small> AMSRD-AAR-AIL-TP(R)		<b>CAUTION: VERIFY PRIOR TO USE AT WWW.DAC.ARMY.MIL THAT THIS IS THE MOST CURRENT VERSION OF THIS DOCUMENT. THIS IS PAGE 1 OF 4.</b>			
<b>APPROVED, U.S. ARMY JOINT MUNITIONS COMMAND</b> <b>CASILLAS.GILBERT.</b> J.1230393644 <small>Digitally signed by CASILLAS.GILBERT. J.1230393644 DN: c=US, o=U.S. Government, ou=DoD, ou=PKI, cn=CASILLAS.GILBERT. J.1230393644 Date: 2008.03.05 06:57:29 -0500</small> AMSJM-LIT		<b>DO NOT SCALE</b>		<b>FEBRUARY 2008</b>	
		<b>ENGINEER OR TECHNICIAN</b>	<b>BASIC</b>	<b>MELVIN SIX</b>	
		<b>REV.</b>			
<b>APPROVED BY ORDER OF COMMANDING GENERAL, U.S. ARMY MATERIEL COMMAND</b> <b>CARNEY.</b> <b>GARY.</b> <b>BURTON.1038</b> <b>708038</b> U.S. ARMY DEFENSE AMMUNITION CENTER <small>Digitally signed by CARNEY.GARY.BURTON.1038708038 DN: c=US, o=U.S. Government, ou=DoD, ou=PKI, ou=USA, cn=CARNEY.GARY.BURTON.1038708038 Date: 2008.03.19 16:06:49 -0500</small>		<b>TRANSPORTATION ENGINEERING DIVISION</b>	<b>FIEFFER.LAURA.</b> A.1230375727 <small>Digitally signed by FIEFFER.LAURA. A.1230375727 DN: cn=FIEFFER.LAURA.A.1230375727, c=US, o=U.S. Government, ou=DoD, PKI, USA Reason: I am approving this document Date: 2008.03.03 14:06:58 -0500</small>		
		<b>VALIDATION ENGINEERING DIVISION</b>	<b>BEAVER.JERRY.</b> W.1230949952 <small>Digitally signed by BEAVER.JERRY. W.1230949952 DN: cn=BEAVER.JERRY. W.1230949952, c=US, o=U.S. Government, ou=DoD, PKI, USA Reason: I am approving this document Date: 2008.03.03 14:07:00 -0500</small>		<b>TESTED</b>
		<b>ENGINEERING DIRECTORATE</b>	<b>NORTUNEN.LARRY.</b> R.1230549628 <small>Digitally signed by NORTUNEN.LARRY. R.1230549628 DN: cn=NORTUNEN.LARRY.R.1230549628, c=US, o=U.S. Government, ou=DoD, PKI, USA Reason: I have reviewed this document Date: 2008.03.03 14:34:03 -0500</small>		
		<b>CLASS</b>	<b>DIVISION</b>	<b>DRAWING</b>	<b>FILE</b>
		<b>19</b>	<b>48</b>	<b>4221/26</b>	<b>20PA1009</b>

PALLET UNIT DATA				
ITEMS INCLUDED		*HAZARD CLASS AND DIVISION	*COMPATIBILITY GROUP	APPROX WEIGHT (LBS)
NSN	DODIC			
1375-01-557-1607	MP22	1.2.3	D	1,253

\*HAZARD AND CLASSIFICATION DATA CONTAINED IN THE ABOVE CHART IS FOR GUIDANCE AND INFORMATIONAL PURPOSES ONLY. VERIFICATION OF THE SPECIFIED DATA SHOULD BE MADE BY CONSULTING THE MOST RECENT JOINT HAZARD CLASSIFICATION SYSTEM LISTING OR OTHER APPROVED LISTING(S).

**MATERIAL SPECIFICATIONS**

- LUMBER** - - - - - : SEE TM 743-200-1 (DUNNAGE LUMBER) AND VOLUNTARY PRODUCT STANDARD PS 20 FOR FILLER ASSEMBLIES. ASTM D6199; CLASS 2, GROUP II, III, OR IV, PRESERVATIVE AND HEAT TREATED FOR OTHER DUNNAGE ASSEMBLIES. NOTE: ONLY GROUP IV LUMBER IN ACCORDANCE WITH ASTM D6199 WILL BE ACCEPTABLE FOR THE CONSTRUCTION OF THE PALLET.
- PALLET** - - - - - : MIL SPEC MIL-P-15011; 4-WAY ENTRY, STYLE 1A, TYPE I, CLASS 1, PRESERVATIVE AND HEAT TREATED
- NAILS** - - - - - : ASTM F1667; COMMON STEEL NAIL (NLCMS OR NLCMMS). ALT: UNDERLAYMENT NAIL (NLUL), PALLET NAIL (NLPL), OR COOLER NAIL (NLCL) OF THE SAME SIZE.
- STRAPPING, STEEL** - - : ASTM D3953; FLAT STRAPPING, TYPE 1, HEAVY DUTY, FINISH B (GRADE 2), SIZE 3/4" X .035" OR .031" OR .029". ALTERNATIVE SIZE 1-1/4" X 035" OR .031" OR .029". NOTE: IF EDGES DO NOT MEET THE PREECE TEST FOR GRADE 2, ANY BRITE OR SLIT EDGES SHALL HAVE A FINISH A OVERLAY APPLIED.
- SEAL, STRAP** - - - - : ASTM D3953; CLASS H, FINISH B (GRADE 2), DOUBLE NOTCH TYPE, STYLE I, II, III, OR IV. ALTERNATIVE SEAL FINISH: SIGNODE OR DELTA PAINTED SEALS MAY BE USED AS AN ALTERNATIVE IF ALL SURFACES ARE PAINTED. GRITTED BACKING IS NOT PERMITTED.

**GENERAL NOTES**

- A. THIS DOCUMENT HAS BEEN PREPARED AND ISSUED IN ACCORDANCE WITH AR 740-1, AND AUGMENTS TM 743-200-1 (CHAPTER 5) AND CONFORMS TO MIL-STD-1660.
- B. DIMENSIONS, CUBE AND WEIGHT OF A PALLET UNIT WILL VARY SLIGHTLY DEPENDING UPON THE ACTUAL DIMENSIONS OF THE BOXES AND THE WEIGHT OF THE SPECIFIC ITEM BEING UNITIZED.
- C. FOR DETAILS OF THE MIL-B-2427 BOX SEE ARDEC DRAWING 13018660.
- D. THE LOAD STRAPS MAY BE THREADED THROUGH THE STRAP SLOTS OF A PALLET OR PRE-POSITIONED ON THE PALLET DECK PRIOR TO PLACING THE BOXES ON THE PALLET. LOAD STRAPS MUST BE TENSIONED AND SEALED AFTER THE APPLICATION OF TIEDOWN STRAPS.
- E. INSTALL EACH TIEDOWN STRAP TO PASS UNDER THE TOP DECK BOARDS OF THE PALLET AND TO BE LOCATED AS SHOWN. TIEDOWN STRAPS MUST BE TENSIONED AND SEALED PRIOR TO THE LOAD STRAPS.
- F. THE FOLLOWING AMC DRAWINGS ARE APPLICABLE FOR UNLOADING AND STORAGE OF THE ITEMS COVERED BY THIS APPENDIX.

- CARLOADING - - - - 19-48-4115-5PA1002
- TRUCKLOADING - - - - 19-48-4117-11PA1003
- STORAGE - - - - 19-48-4118-1-2-3-4-14-22PA1002
- END OPENING ISO CONTAINER - - - - 19-48-4153-15PA1002
- MILVAN - - - - 19-48-4166-15PA1003
- SIDE OPENING ISO CONTAINER - - - - 19-48-4267-15PA1009

- G. IF ITEMS COVERED HEREIN ARE UNITIZED PRIOR TO ISSUANCE OF THIS DRAWING, THE BOXES NEED NOT BE REUNITIZED SOLELY TO CONFORM TO THIS DRAWING.
- H. THE UNITIZATION PROCEDURES DEPICTED HEREIN MAY ALSO BE USED FOR UNITIZING ARMOR TILES WHEN IDENTIFIED BY DIFFERENT NATIONAL STOCK NUMBERS (NSN) THAN WHAT IS SHOWN ON PAGE 2, PROVIDED THE BOX PACK DOES NOT VARY FROM WHAT IS DELINEATED HEREIN. THE EXPLOSIVE CLASSIFICATION OF OTHER ITEMS MAY BE DIFFERENT THAN WHAT IS SHOWN.
- J. THE STYLE 1A PALLET DELINEATED IN THE DETAIL AT LEFT NEED NOT HAVE CHAMFERS OR STRAP SLOTS AS SPECIFIED WITHIN MILITARY SPECIFICATION MIL-P-15011 WHEN USED FOR THE UNITIZATION OF ITEMS COVERED BY THIS APPENDIX.
- K. WHEN APPLYING ANY STRAP, CARE MUST BE EXERCISED TO ASSURE THAT THE END OF THE STRAP ON THE UNDERSIDE OF THE JOINT EXTENDS AT LEAST 6" BEYOND THE SEAL. THIS EXTRA MINIMUM LENGTH OF STRAP IS REQUIRED TO PERMIT SUBSEQUENT TIGHTENING OF LOOSENED STRAPPING. RETENSIONING CAN BE ACCOMPLISHED WITHOUT REPLACING STRAPPING OR SPLICING STRAPPING THROUGH THE USE OF A MANUAL OR PNEUMATIC FEEDWHEEL TYPE TENSIONING TOOL AND THE APPLICATION OF ONE ADDITIONAL SEAL.
- L. IN ORDER TO OBTAIN COMPACT (SOUND) UNITS, ALL STRAPS SHALL BE LOCATED IN PROPER ALIGNMENT AND TENSIONED UNTIL THE CUT INTO THE EDGE OF THE PALLET DECK. AFTER TENSIONING, ALL STRAPS WILL BE SECURED USING ONE SEAL AND TWO PAIR OF NOTCHES.
- M. A PLUS OR MINUS 1/4" IS ALLOWED ON OVERALL DIMENSIONS OF ANY DUNNAGE ASSEMBLY. HOWEVER, SIMILAR PIECES IN AN ASSEMBLY MUST BE WITHIN 1/8" OF THE SAME DIMENSION.
- N. DIMENSIONAL LUMBER SPECIFIED THROUGHOUT THIS PROCEDURAL DRAWING IS OF A NOMINAL SIZE UNLESS OTHERWISE SPECIFIED, FOR EXAMPLE, 1" X 4" MATERIAL IS ACTUALLY 3/4" THICK BY 3-1/2" WIDE.

- O. UNIT LOAD MARKINGS WILL BE ACCOMPLISHED IN ACCORDANCE WITH DAC DRAWING ACV00561, UNIT LOAD MARKING FOR SHIPMENT AND STORAGE, AMMUNITION AND EXPLOSIVES.
- P. DIMENSIONS GIVEN FOR DUNNAGE ASSEMBLIES WILL BE FIELD CHECKED PRIOR TO THEIR ASSEMBLY. THIS GUIDANCE MUST BE APPLIED PRIOR TO BEGINNING A PALLETIZATION OPERATION. ALSO, DUE TO VARIATIONS OF PACK-AGE DIMENSIONS, ADJUSTMENTS MAY BE REQUIRED AS TO THE LOCATION OF CERTAIN PIECES ON DUNNAGE ASSEMBLIES. THESE ASSEMBLIES SHALL NOT PROTRUDE PAST THE TOP AND/OR SIDES OF THE BOXES.

(CONTINUED ON PAGE 4)

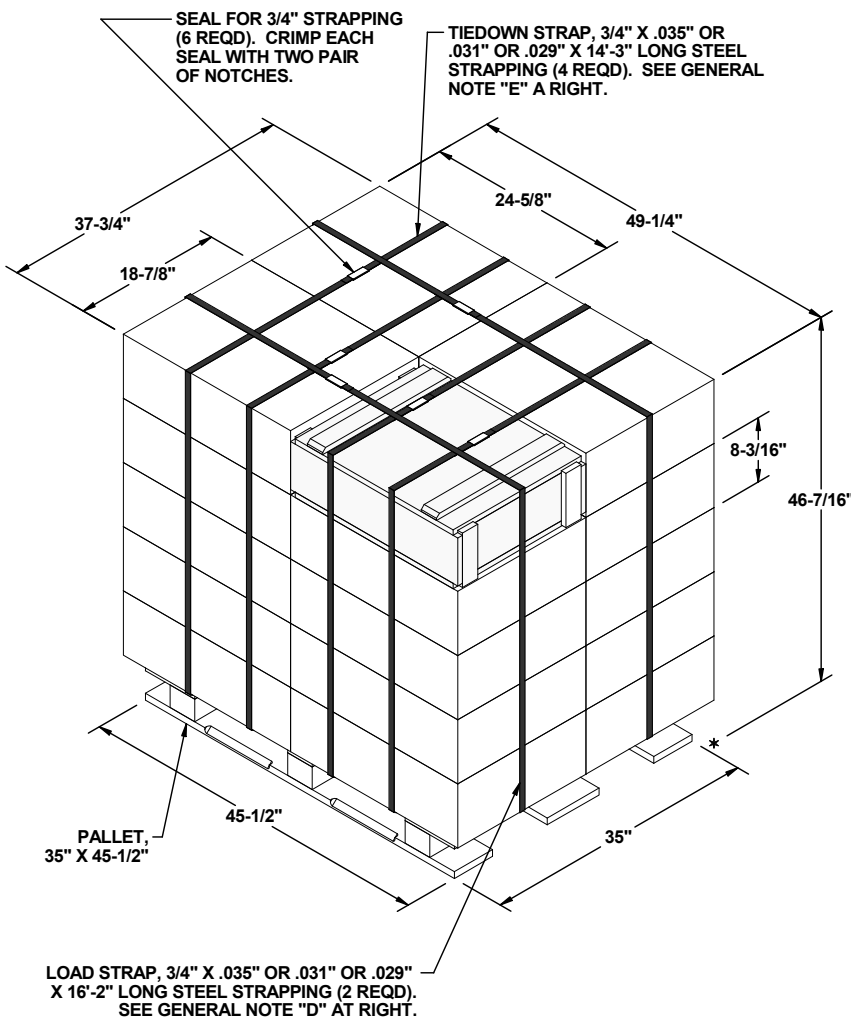

**PALLET UNIT**  
SEE GENERAL NOTE "B" AT RIGHT.

20 BOXES OF ARMOR TILES (1 PER BOX) @ 59 LBS	-----	1,180 LBS	
DUNNAGE	-----	8 LBS	
PALLET	-----	65 LBS	
<b>TOTAL WEIGHT</b>		-----	<b>1,253 LBS (APPROX)</b>
<b>CUBE</b>		-----	<b>50.0 CU FT (APPROX)</b>

<b>BILL OF MATERIAL</b>				
PALLET, 35" X 45-1/2"	-----	1 REQD	-----	65 LBS
STEEL STRAPPING, 3/4"	-----	89.33' REQD	-----	7.98 LBS
SEAL FOR 3/4" STRAPPING	-----	6 REQD	-----	NIL

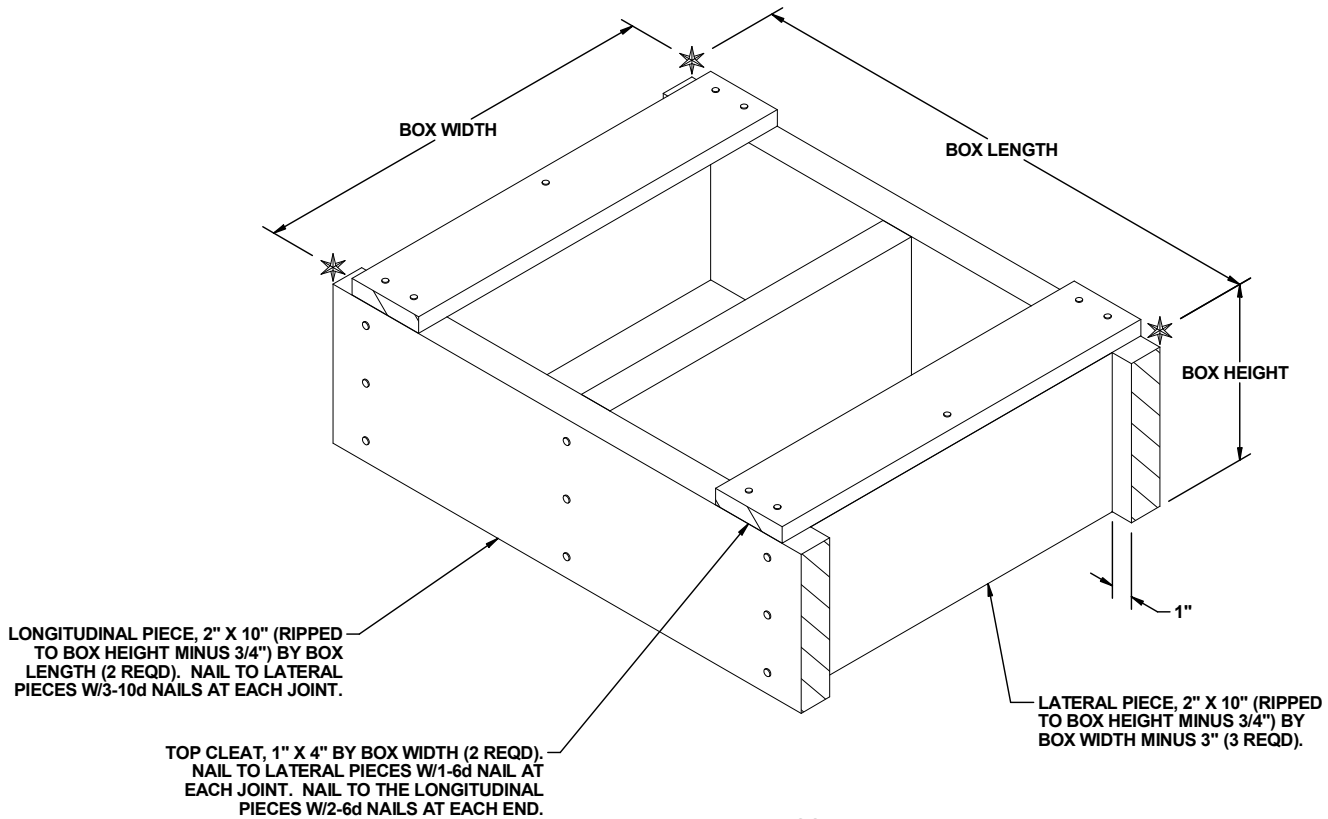

LONGITUDINAL PIECE, 2" X 10" (RIPPED TO BOX HEIGHT MINUS 3/4") BY BOX LENGTH (2 REQD). NAIL TO LATERAL PIECES W/3-10d NAILS AT EACH JOINT.

TOP CLEAT, 1" X 4" BY BOX WIDTH (2 REQD). NAIL TO LATERAL PIECES W/1-6d NAIL AT EACH JOINT. NAIL TO THE LONGITUDINAL PIECES W/2-6d NAILS AT EACH END.

LATERAL PIECE, 2" X 10" (RIPPED TO BOX HEIGHT MINUS 3/4") BY BOX WIDTH MINUS 3" (3 REQD).

**FILLER ASSEMBLY**  
(FOR MINUS ONE BOX)

(GENERAL NOTES CONTINUED FROM PAGE 3)

- Q. ALL WOODEN DUNNAGE AND PALLETS MUST BE PRESERVATIVE TREATED IN ACCORDANCE WITH THE PROCEDURES SPECIFIED IN MIL-B-2427 FOR CLEATED WOODEN BOXES. IF THE DUNNAGE CONSISTS OF MORE THAN ONE COMPONENT, IT MUST BE ASSEMBLED PRIOR TO TREATMENT. THE LETTERS PA DENOTING PQ56 (COPPER-8-QUINOLINOLATE), PB DENOTING M-GARD W550 (ZINC NAPHTHANATE EMULSIFIABLE) OR PC DENOTING M-GARD W510, CUNAPSOL 5 (COPPER NAPHTHANATE) MUST BE APPLIED TO THE WOOD DUNNAGE IN LETTERS AT LEAST ONE-INCH HIGH.
- R. COOLER NAILS MAY BE SUBSTITUTED FOR THE COMMON NAILS AS SPECIFIED WITHIN EACH APPENDIX BY APPLYING THE FOLLOWING GUIDANCE. THE NUMBER OF COOLER NAILS TO BE USED WILL BE THE NUMBER OF COMMON NAILS MULTIPLIED BY 1.2 AND ROUNDED UP TO THE NEXT WHOLE NUMBER. THE SIZE OF THE COOLER NAILS TO BE USED WILL BE THE SAME AS SPECIFIED FOR THE COMMON NAILS (4d, 6d, 10d, ETC.) BUT WILL CONFORM TO THE SIZE AND WEIGHT TOLERANCES SPECIFIED WITHIN ASTM F1667 FOR COOLER NAILS.
- S. ALL NON-MANUFACTURED WOOD USED IN THE PALLETIZED LOAD SHALL BE HEAT TREATED TO A CORE TEMPERATURE OF 56 DEGREES CELSIUS FOR A MINIMUM OF 30 MINUTES. THE PALLET MANUFACTURER AND THE MANUFACTURER OF WOOD TO BUILD FILLER ASSEMBLIES AND DUNNAGE ASSEMBLIES FOR THE PALLETIZED LOAD SHALL BE AFFILIATED WITH AN INSPECTION AGENCY ACCREDITED BY THE U.S. DEPARTMENT OF AGRICULTURE. THE PALLET MANUFACTURER AND THE MANUFACTURER OF WOOD USED TO BUILD FILLER ASSEMBLIES AND DUNNAGE ASSEMBLIES FOR THE PALLETIZED LOAD SHALL ENSURE TRACEABILITY TO THE ORIGINAL SOURCE OF HEAT TREATMENT. EACH PALLET, FILLER ASSEMBLY, OR DUNNAGE ASSEMBLY SHALL BE MARKED TO SHOW THE CONFORMANCE TO THE INTERNATIONAL PLANT PROTECTION CONVENTION STANDARD. PALLETS, FILLER ASSEMBLIES, AND DUNNAGE ASSEMBLIES MADE OF NON-MANUFACTURED WOOD SHALL BE HEAT TREATED AND MARKED APPROPRIATELY. THE QUALITY MARK FOR THE PALLET SHALL BE PLACED ON TWO OPPOSITE END POST ON THE SAME SIDE AS THE PRESERVATIVE MARKING. THE QUALITY MARK FOR THE FILLER ASSEMBLIES AND DUNNAGE ASSEMBLIES SHALL BE PLACED ON TWO OPPOSITE SIDES.