

UNITIZATION PROCEDURES FOR STRYKER ARMOR TILE SET SPARE PARTS ON 4-WAY ENTRY PALLETS

ARMOR TILE, M20 (UPPER GLACIS, L-BOX, TOP MODULE), M21 (UPPER GLACIS, L-BOX, BOTTOM MODULE), M25 (UPPER GLACIS, LARGE BOX, TOP MODULE), M26 (UPPER GLACIS, LARGE BOX, BOTTOM MODULE) PACKED ONE PER WOODEN BOX, UNITIZED 20 BOXES PER 35" X 45-1/2" PALLET; APPROX BOX SIZE 23-5/16" L X 18-11/16" W X 7-1/2" H

DISTRIBUTION STATEMENT A:

APPROVED FOR PUBLIC RELEASE
DISTRIBUTION IS UNLIMITED.

U.S. ARMY MATERIEL COMMAND DRAWING

APPROVED, U.S. ARMY RESEARCH, DEVELOPMENT
AND ENGINEERING COMMAND *Trovis*

David A. Pedroni
AMSJD-AAR-AIL-TP

APPROVED, U.S. ARMY
JOINT MUNITIONS COMMAND
Scott ...
AMSJM-LIT

APPROVED BY ORDER OF COMMANDING
GENERAL, U.S. ARMY MATERIEL COMMAND

Charles P. Spoo
U.S. ARMY DEFENSE AMMUNITION CENTER

CAUTION: VERIFY PRIOR TO USE AT WWW.DAC.ARMY.MIL THAT THIS IS THE MOST CURRENT VERSION OF THIS DOCUMENT. THIS IS PAGE 1 OF 4.

DO NOT SCALE

OCTOBER 2006

ENGINEER OR TECHNICIAN	BASIC REV.	PATRICK DOUGHERTY
------------------------	------------	-------------------

TRANSPORTATION ENGINEERING DIVISION *Kevin A. ...*

VALIDATION ENGINEERING DIVISION *Philip W. ...* TESTED

ENGINEERING DIRECTORATE *Debra W. ...*

CLASS	DIVISION	DRAWING	FILE
19	48	4221/19	20PA1009

PALLET UNIT DATA				
ITEMS INCLUDED		*HAZARD CLASS AND DIVISION	*COMPATI- BILITY GROUP	APPROX WEIGHT (LBS)
NSN	DODIC			
2540-				
01-523-4520	----	---- I NERT	----	1,966
01-523-4528	----	---- I NERT	----	1,966
01-523-4529	----	---- I NERT	----	1,966
01-523-4530	----	---- I NERT	----	1,966

*HAZARD AND CLASSIFICATION DATA CONTAINED IN THE ABOVE CHART IS FOR GUIDANCE AND INFORMATIONAL PURPOSES ONLY. VERIFICATION OF THE SPECIFIED DATA SHOULD BE MADE BY CONSULTING THE MOST RECENT JOINT HAZARD CLASSIFICATION SYSTEM LISTING OR OTHER APPROVED LISTING(S).

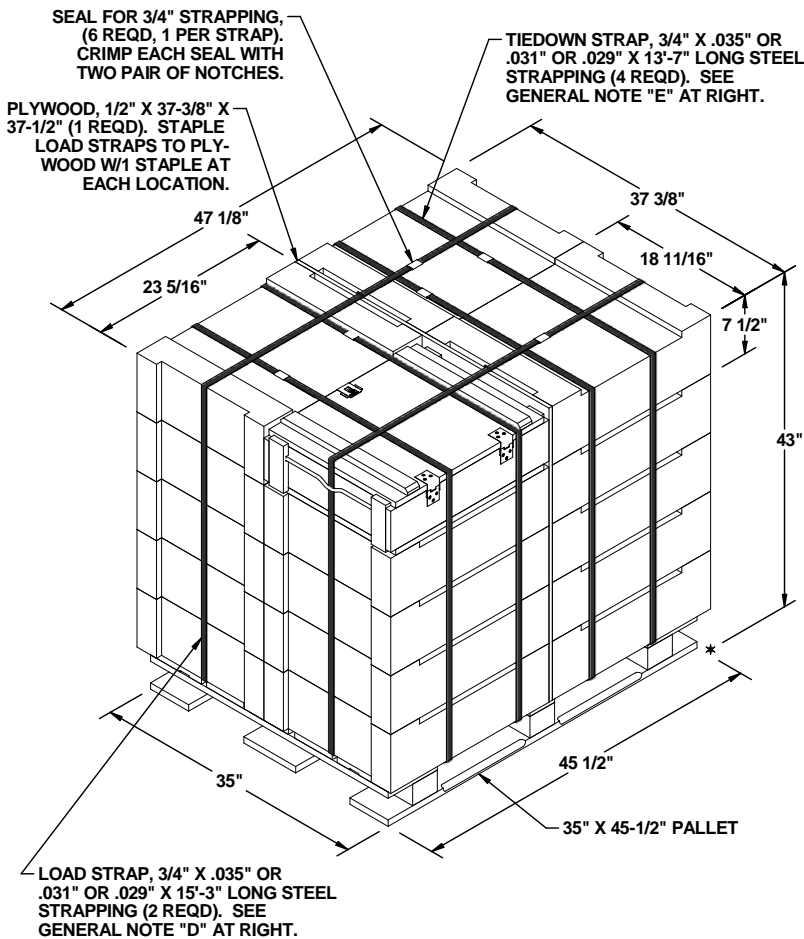

PALLET UNIT
SEE GENERAL NOTE "B" AT RIGHT.

20 BOXES OF ARMOR TILES (1 PER BOX) @ 94 LBS	1,880 LBS
DUNNAGE	21 LBS
PALLET	65 LBS
<hr/>	
TOTAL WEIGHT	1,966 LBS (APPROX)
CUBE	43.8 CU FT (APPROX)

BILL OF MATERIAL

PALLET, 35" X 45-1/2"	1 REQD	65 LBS
PLYWOOD, 1/2"	9.73 SQ FT REQD	13.38 LBS
STEEL STRAPPING, 3/4"	84.83' REQD	7.57 LBS
SEAL FOR 3/4" STRAPPING	6 REQD	NIL
STAPLE, 15/16" X 3/4"	2 REQD	NIL

GENERAL NOTES

- A. THIS DOCUMENT HAS BEEN PREPARED AND ISSUED IN ACCORDANCE WITH AR 740-1, AND AUGMENTS TM 743-200-1 (CHAPTER 5) AND CONFORMS TO MIL-STD-1660.
- B. DIMENSIONS, CUBE AND WEIGHT OF A PALLET UNIT WILL VARY SLIGHTLY DEPENDING UPON THE ACTUAL DIMENSIONS OF THE BOXES AND THE WEIGHT OF THE SPECIFIC ITEM BEING UNITIZED.
- C. FOR DETAILS OF THE MIL-B-2427 BOX SEE ARDEC DRAWING 13005869-5.
- D. THE LOAD STRAPS MAY BE THREADED THROUGH THE STRAP SLOTS OF A PALLET OR PRE-POSITIONED ON THE PALLET DECK PRIOR TO PLACING THE BOXES ON THE PALLET. LOAD STRAPS ALSO MAY BE THREADED THROUGH THE ROPE HANDLES OF THE BOXES TO PREVENT DAMAGE TO THE HANDLES. LOAD STRAPS WILL NOT BE APPLIED UNTIL THE TIEDOWN STRAPS HAVE BEEN TENSIONED AND SEALED.
- E. INSTALL EACH TIEDOWN STRAP TO PASS UNDER THE TOP DECK BOARDS OF THE PALLET AND TO BE LOCATED AS SHOWN. TIEDOWN STRAPS MUST BE TENSIONED AND SEALED PRIOR TO APPLICATION OF THE LOAD STRAPS.
- F. THE FOLLOWING AMC DRAWINGS ARE APPLICABLE FOR OUTLOADING AND STORAGE OF THE ITEMS COVERED BY THIS APPENDIX.

CARLOADING	19-48-4115-5PA1002
TRUCKLOADING	19-48-4117-11PA1003
STORAGE	19-48-4118-1-2-3-4-14-22PA1002
END OPENING ISO	
CONTAINER	19-48-4153-15PA1002
MILVAN	19-48-4166-15PA1003
SIDE OPENING ISO	
CONTAINER	19-48-4267-15PA1009
- G. IF ITEMS COVERED HEREIN ARE UNITIZED PRIOR TO ISSUANCE OF THIS DRAWING, THE BOXES NEED NOT BE REUNITIZED SOLELY TO CONFORM TO THIS DRAWING.
- J. THE STYLE 1A PALLET DELINEATED IN THE DETAIL AT LEFT NEED NOT HAVE CHAMFERS OR STRAP SLOTS AS SPECIFIED WITHIN MILITARY SPECIFICATION MIL-P-15011 WHEN USED FOR THE UNITIZATION OF ITEMS COVERED BY THIS APPENDIX.
- K. WHEN APPLYING ANY STRAP, CARE MUST BE EXERCISED TO ASSURE THAT THE END OF THE STRAP ON THE UNDERSIDE OF THE JOINT EXTENDS AT LEAST 6" BEYOND THE SEAL. THIS EXTRA MINIMUM LENGTH OF STRAP IS REQUIRED TO PERMIT SUBSEQUENT TIGHTENING OF LOOSENED STRAPPING. RETENSIONING CAN BE ACCOMPLISHED WITHOUT REPLACING STRAPPING OR SPLICING STRAPPING THROUGH THE USE OF A MANUAL OR PNEUMATIC FEEDWHEEL TYPE TENSIONING TOOL AND THE APPLICATION OF ONE ADDITIONAL SEAL.
- L. IN ORDER TO OBTAIN COMPACT (SOUND) UNITS, ALL STRAPS SHALL BE LOCATED IN PROPER ALIGNMENT AND TENSIONED UNTIL THE CUT INTO THE EDGE OF THE PALLET DECK. AFTER TENSIONING, ALL STRAPS WILL BE SECURED USING ONE SEAL AND TWO PAIR OF NOTCHES.
- M. A PLUS OR MINUS 1/4" IS ALLOWED ON OVERALL DIMENSIONS OF ANY DUNNAGE ASSEMBLY. HOWEVER, SIMILAR PIECES IN AN ASSEMBLY MUST BE WITHIN 1/8" OF THE SAME DIMENSION.
- N. DIMENSIONAL LUMBER SPECIFIED THROUGHOUT THIS PROCEDURAL DRAWING IS OF A NOMINAL SIZE UNLESS OTHERWISE SPECIFIED, FOR EXAMPLE, 1" X 4" MATERIAL IS ACTUALLY 3/4" THICK BY 3-1/2" WIDE.
- O. COOLER NAILS MAY BE SUBSTITUTED FOR THE COMMON NAILS AS SPECIFIED BY APPLYING THE FOLLOWING GUIDANCE: THE NUMBER OF COOLER NAILS TO BE USED WILL BE THE NUMBER OF COMMON NAILS MULTIPLIED BY 1.2 AND ROUNDED UP TO THE NEXT WHOLE NUMBER. THE SIZE OF THE COOLER NAILS TO BE USED WILL BE THE SAME AS SPECIFIED FOR THE COMMON NAILS (4d, 6d, 10d, ETC.) BUT WILL CONFORM TO THE SIZE AND WEIGHT TOLERANCE SPECIFIED WITHIN ASTM F1667 FOR COOLER NAILS.
- P. UNIT LOAD MARKING WILL BE ACCOMPLISHED IN ACCORDANCE WITH DAC DRAWING ACV00561, UNIT LOAD MARKING FOR SHIPMENT AND STORAGE, AMMUNITION AND EXPLOSIVES.

(CONTINUED ON PAGE 4)

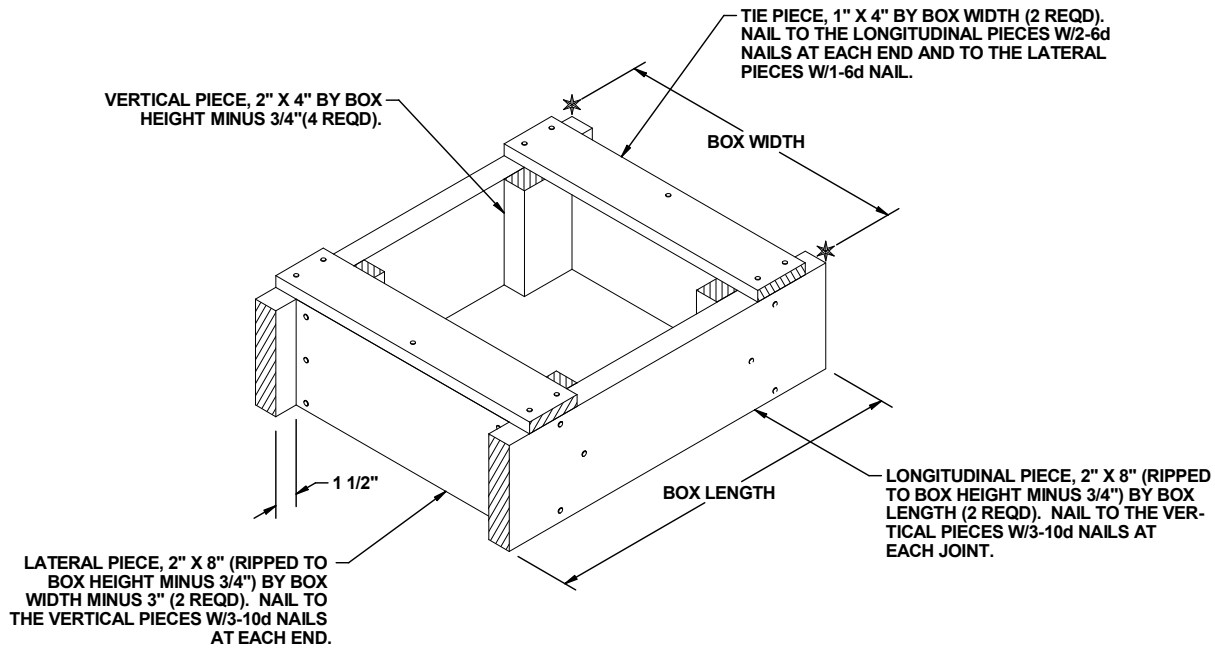

**FILLER ASSEMBLY
(FOR MINUS ONE BOX)**

MATERIAL SPECIFICATIONS

- LUMBER** - - - - - : SEE TM 743-200-1 (DUNNAGE LUMBER) AND VOLUNTARY PRODUCT STANDARD PS 20 FOR FILLER ASSEMBLIES. ASTM D 6199; CLASS 2, GROUP II, III, OR IV, PRESERVATIVE AND HEAT TREATED FOR OTHER DUNNAGE ASSEMBLIES. NOTE: ONLY GROUP IV LUMBER IN ACCORDANCE WITH ASTM D6199 WILL BE ACCEPTABLE FOR THE CONSTRUCTION OF THE PALLET.
- PALLET** - - - - - : MIL SPEC MIL-P-15011; 4-WAY ENTRY, STYLE 1A, TYPE I, CLASS 1, PRESERVATIVE AND HEAT TREATED
- NAILS** - - - - - : ASTM F1667; COMMON STEEL NAIL (NLCMS OR NLCMS). ALT: UNDERLAYMENT NAIL (NLUL), PALLET NAIL (NLPL), OR COOLER NAIL (NLCL) OF SAME SIZE.
- PLYWOOD** - - - - - : COMMERCIAL ITEM DESCRIPTION A-A-55057, INDUSTRIAL PLYWOOD, INTERIOR WITH EXTERIOR GLUE, GRADE C-D. IF SPECIFIED GRADE IS NOT AVAILABLE, A BETTER INTERIOR OR AN EXTERIOR GRADE MAY BE SUBSTITUTED.
- STRAPPING, STEEL** - - - - - : ASTM D3953; FLAT STRAPPING, TYPE 1, HEAVY DUTY, FINISH B (GRADE 2), SIZE 3/4" X .035" OR .031" OR .029". ALTERNATIVE SIZE 1-1/4" X 035" OR .031" OR .029". NOTE: IF EDGES DO NOT MEET THE PRECEE TEST FOR GRADE 2, ANY BRITE OR SLIT EDGES MUST HAVE FINISH A OVERLAY APPLIED.
- SEAL, STRAP** - - - - - : ASTM D3953; CLASS H, FINISH B (GRADE 2), DOUBLE NOTCH TYPE, STYLE I, II, III, OR IV. ALTERNATIVE SEAL FINISH: SIGNODE OR DELTA PAINTED SEALS MAY BE USED AS AN ALTERNATIVE IF ALL SURFACES ARE PAINTED. GRITTED BACKING IS NOT PERMITTED.
- STAPLE** - - - - - : ASTM F1667; STFCs-189, STFCs-198, STFCs-207, OR STFCs-216, 15/16" OR 1" CROWN WIDTH X 3/4" LEG LENGTH FOR 3/4" STRAPPING OR STFCs-224, 1-17/32" CROWN WIDTH X 3/4" LEG LENGTH FOR 1-1/4" STRAPPING.

(GENERAL NOTES CONTINUED FROM PAGE 3)

- Q. DIMENSIONS GIVEN FOR DUNNAGE ASSEMBLIES WILL BE FIELD CHECKED PRIOR TO THEIR ASSEMBLY. THIS GUIDANCE MUST BE APPLIED PRIOR TO BEGINNING A PALLETIZATION OPERATION. ALSO, DUE TO VARIATIONS OF PACKAGE DIMENSIONS, ADJUSTMENTS MAY BE REQUIRED AS TO THE LOCATION OF CERTAIN PIECES ON DUNNAGE ASSEMBLIES. THESE ASSEMBLIES SHALL NOT PROTRUDE PAST THE TOP AND/OR SIDES OF THE BOXES.**
- R. ALL WOODEN DUNNAGE AND PALLETS MUST BE PRESERVATIVE TREATED IN ACCORDANCE WITH THE PROCEDURES SPECIFIED IN MIL-B-2427 FOR CLEATED WOODEN BOXES. IF THE DUNNAGE CONSISTS OF MORE THAN ONE COMPONENT, IT MUST BE ASSEMBLED PRIOR TO TREATMENT. THE LETTERS PA DENOTING P056 (COPPER-8-QUINOLINOLATE), PB DENOTING M-GARD W550 (ZINC NAPHTHANATE EMULSIFIABLE) OR PC DENOTING M-GARD W510 OR CUNAPSOL 5 (COPPER NAPHTHANATE) MUST BE APPLIED TO THE WOOD DUNNAGE IN LETTERS AT LEAST ONE-INCH HIGH.**
- S. ALL NON-MANUFACTURED WOOD USED IN THE PALLETIZED LOAD SHALL BE HEAT TREATED TO A CORE TEMPERATURE OF 56 DEGREES CELSIUS FOR A MINIMUM OF 30 MINUTES. THE PALLET MANUFACTURER AND THE MANUFACTURER OF WOOD TO BUILD FILLER ASSEMBLIES AND DUNNAGE ASSEMBLIES FOR THE PALLETIZED LOAD SHALL BE AFFILIATED WITH AN INSPECTION AGENCY ACCREDITED BY THE U.S. DEPARTMENT OF AGRICULTURE. THE PALLET MANUFACTURER AND THE MANUFACTURER OF WOOD USED TO BUILD FILLER ASSEMBLIES AND DUNNAGE ASSEMBLIES FOR THE PALLETIZED LOAD SHALL ENSURE TRACEABILITY TO THE ORIGINAL SOURCE OF HEAT TREATMENT. EACH PALLET, FILLER ASSEMBLY, OR DUNNAGE ASSEMBLY SHALL BE MARKED TO SHOW THE CONFORMANCE TO THE INTERNATIONAL PLANT PROTECTION CONVENTION STANDARD. PALLETS, FILLER ASSEMBLIES, AND DUNNAGE ASSEMBLIES MADE OF NON-MANUFACTURED WOOD SHALL BE HEAT TREATED AND MARKED APPROPRIATELY. THE QUALITY MARK FOR THE PALLET SHALL BE PLACED ON TWO OPPOSITE END POST ON THE SAME SIDE AS THE PRESERVATIVE MARKING. THE QUALITY MARK FOR THE FILLER ASSEMBLIES AND DUNNAGE ASSEMBLIES SHALL BE PLACED ON TWO OPPOSITE SIDES.**