

APPROVED BY
BUREAU OF EXPLOSIVES

dan healy Digitally signed by dan healy
DN: cn=dan healy, o, ou,
email=dan_healy@aar.com,
c=US
Date: 2011.10.28 12:25:00 -05'00'

LOADING AND BRACING[⊕] IN END OPENING ISO CONTAINERS OF 105MM APFSDS-T M833 CAR- TRIDGE, PACKED IN PA117 CYLIN- DRICAL CONTAINERS, PALLETIZED

INDEX

ITEM	PAGE(S)
TYPICAL LOADING PROCEDURES - - - - -	2
GENERAL NOTES AND MATERIAL SPECIFICATIONS - - - - -	3
PALLET UNIT DETAILS - - - - -	4
DETAILS - - - - -	5-7
LESS-THAN-FULL-LOAD PROCEDURES - - - - -	8

DISTRIBUTION STATEMENT A:

APPROVED FOR PUBLIC RELEASE
DISTRIBUTION IS UNLIMITED.

⊕ THE PROCEDURES SHOWN HEREIN ARE APPLICABLE TO LOADS THAT ARE TO BE SHIPPED BY TRAILER/CONTAINER-ON-FLATCAR (T/COFC) RAIL, MOTOR, OR WATER CARRIERS.

U.S. ARMY MATERIEL COMMAND DRAWING

<p>APPROVED, U.S. ARMY JOINT MUNITIONS COMMAND</p> <p>RUS.ALLEN.J .1230354282 <small>Digitally signed by RUS.ALLEN.J.1230354282 DN: cn=US, ou=U.S. Government, ou=DoD, ou=PKI, ou=USA, cn=RUS.ALLEN.J.1230354282 Date: 2012.02.01 16:39:51 -06'00'</small></p>		<p>CAUTION: VERIFY PRIOR TO USE AT WWW.DAC.ARMY.MIL THAT THIS IS THE MOST CURRENT VERSION OF THIS DOCUMENT. THIS IS PAGE 1 OF 8.</p>			
		<p>DO NOT SCALE</p>		<p>OCTOBER 1991</p>	
		<p>ENGINEER OR TECHNICIAN</p>	<p>BASIC REV.</p>	<p>LAURA FIEFFER SPENCER HOVEY</p>	
<p>APPROVED BY ORDER OF COMMANDING GENERAL, U.S. ARMY MATERIEL COMMAND</p> <p>CARNEY.GARY.BURTON.1038708038 <small>Digitally signed by CARNEY.GARY.BURTON.1038708038 DN: cn=US, ou=U.S. Government, ou=DoD, ou=PKI, ou=USA, cn=CARNEY.GARY.BURTON.1038708038 Date: 2012.02.02 09:47:53 -06'00'</small></p>		<p>TRANSPORTATION ENGINEERING DIVISION</p>	<p>FIEFFER.LAUR A.A.1230375727 <small>Digitally signed by FIEFFER.LAURA.A.1230375727 DN: cn=US, ou=U.S. Government, ou=DoD, ou=PKI, ou=USA, cn=FIEFFER.LAURA.A.1230375727 Date: 2011.10.25 14:52:22 -05'00'</small></p>	<p>REVISION NO. 1</p>	<p>NOVEMBER 2011</p>
		<p>VALIDATION ENGINEERING DIVISION</p>	<p>BARICKMAN .PHILIP.W.12 30202202 <small>Digitally signed by BARICKMAN.PHILIP.W.1230202202 DN: cn=US, ou=U.S. Government, ou=DoD, ou=PKI, ou=USA, cn=BARICKMAN.PHILIP.W.1230202202 Date: 2011.10.25 16:32:02 -05'00'</small></p>	<p>SEE THE REVISION LISTING ON PAGE 3</p>	
<p>U.S. ARMY DEFENSE AMMUNITION CENTER</p>		<p>ENGINEERING DIRECTORATE</p>	<p>BEAVER.JERRY .W.1230949952 <small>Digitally signed by BEAVER.JERRY.W.1230949952 DN: cn=US, ou=U.S. Government, ou=DoD, ou=PKI, ou=USA, cn=BEAVER.JERRY.W.1230949952 Date: 2011.10.28 08:58:01 -05'00'</small></p>	<p>CLASS</p>	<p>DIVISION</p>
				<p>19</p>	<p>48</p>
				<p>4215/9A</p>	<p>15PM1013</p>

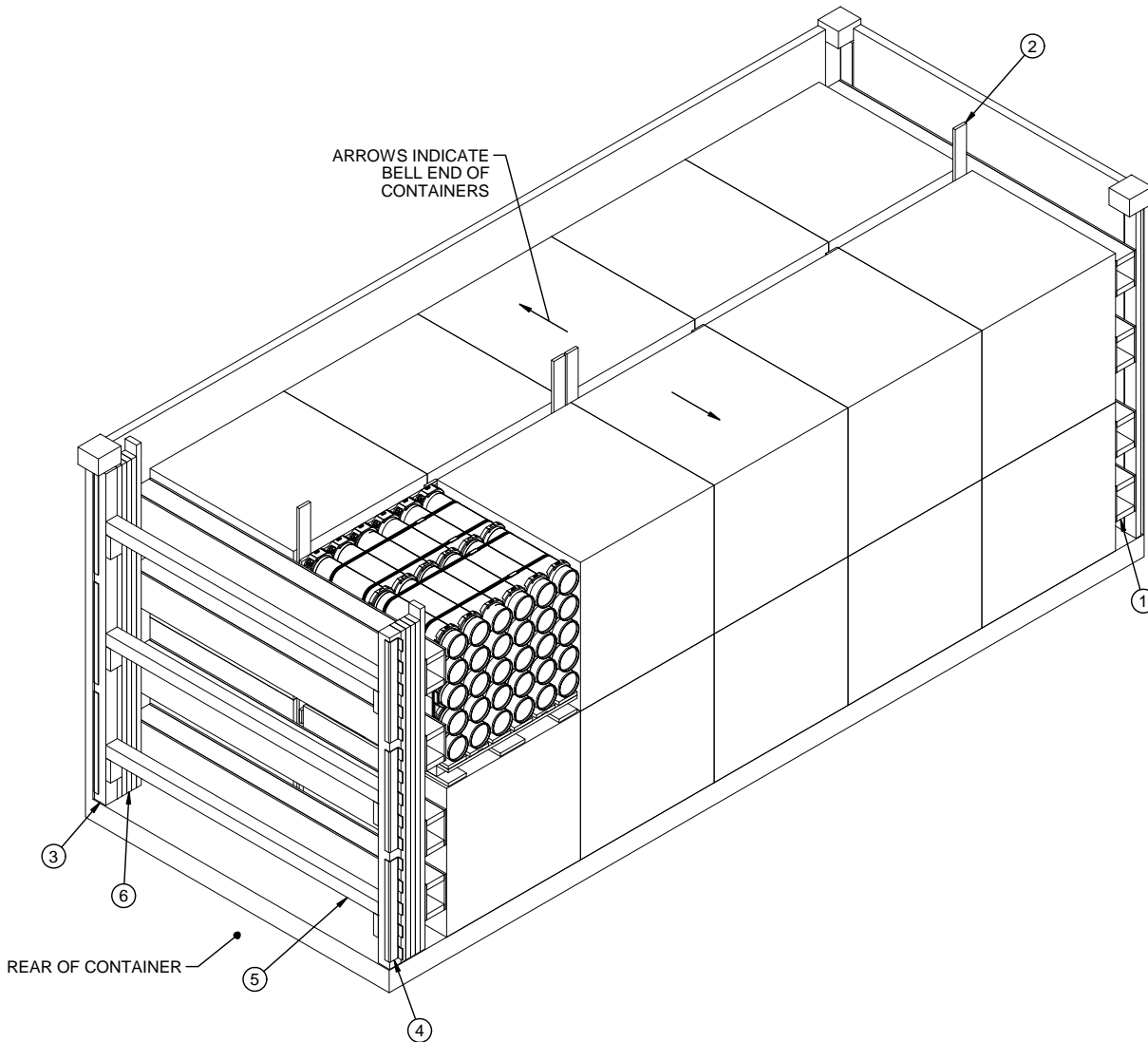

ISOMETRIC VIEW

KEY NUMBERS

- ① FORWARD/REAR BLOCKING ASSEMBLY (2 REQD). SEE THE DETAIL ON PAGE 5.
- ② CENTER FILL ASSEMBLY (2 REQD). SEE THE DETAIL ON PAGE 6.
- ③ DOOR POST VERTICAL (2 REQD). SEE THE "DOOR POST VERTICAL" DETAIL AND "DETAIL A" ON PAGE 7.
- ④ UNIVERSAL LOAD RETAINER (6 REQD, 3 PER SIDE). NAIL THROUGH THE HOLES INTO THE DOOR POST VERTICAL W/2-10d NAILS. SEE THE DEPARTMENT OF ARMY DRAWING DA-116, "DETAIL A" ON PAGE 7, AND GENERAL NOTE "Q" ON PAGE 3.
- ⑤ DOOR SPANNER, 4" X 4" MATERIAL CUT TO A LENGTH THAT WILL PROVIDE A DRIVE FIT (REF: 7'-1-3/8") (3 REQD). TOENAIL TO THE DOOR POST VERTICAL W/2-12d NAILS AT EACH END. SEE THE "BEVEL-CUT" DETAIL ON PAGE 6.
- ⑥ FILL MATERIAL, 4" WIDE BY 7'-0" LONG MATERIAL (AS REQD). NAIL THE FIRST PIECE TO THE REAR BLOCKING ASSEMBLY W/6 NAILS OF A SUITABLE SIZE (10d FOR 2" THICK MATERIAL). NAIL EACH ADDITIONAL PIECE TO THE PREVIOUS PIECE IN A SIMILAR MANNER. NOTE: MULTIPLE PIECES MAY BE LAMINATED TOGETHER FIRST AND THEN TOENAILED TO THE REAR BLOCKING ASSEMBLY. SEE "DETAIL A" ON PAGE 7.

BILL OF MATERIAL

LUMBER	LINEAR FEET	BOARD FEET
1" x 4"	119	40
2" x 4"	89	59
2" x 6"	123	123
4" x 4"	36	49
NAI LS	NO. REQD	POUNDS
4d (1-1/2")	56	1/4
6d (2")	384	2 3/8
10d (3")	216	3 3/8
12d (3-1/4")	12	1/4
PLYWOOD, 1/2" - - 97.11 SQ FT REQD - 133.53 LBS		
UNIVERSAL LOAD RETAINER - - 6 REQD - - - 39 LBS		

LOAD AS SHOWN

ITEM	QUANTITY	WEIGHT (APPROX)
PALLET UNIT	20	36,080 LBS
DUNNAGE		681 LBS
CONTAINER		4,700 LBS
TOTAL WEIGHT		41,461 LBS

GENERAL NOTES

- A. THIS DOCUMENT HAS BEEN PREPARED AND ISSUED IN ACCORDANCE WITH AR 740-1 AND AUGMENTS TM 743-200-1 (CHAPTER 5).
- B. THE SPECIFIED OUTLOADING PROCEDURES ARE APPLICABLE TO LOADS OF 105MM CARTRIDGES IN PA117 CONTAINERS, PALLETIZED. SUBSEQUENT REFERENCE TO PALLET UNIT HEREIN MEANS THE PALLET UNIT WITH AMMUNITION ITEMS. SEE PAGE 4 AND AMC DRAWING 19-48-4079/8A-20PM1002 FOR DETAILS OF THE PALLET UNIT. **CAUTION:** REGARDLESS OF THE QUANTITY OF CONTAINERS TO BE SHIPPED, THE "MAXIMUM GROSS WEIGHT" OF THE END OPENING ISO CONTAINER MUST NOT BE EXCEEDED.
- C. THE LOAD AS SHOWN IS BASED ON A 4,700 POUND 20' LONG BY 8' WIDE BY 8'-6" HIGH END OPENING ISO CONTAINER WITH INSIDE DIMENSIONS OF 19'-4" LONG BY 92" WIDE BY 93" HIGH, WITH A MAXIMUM GROSS WEIGHT OF 52,910 POUNDS. OLDER/OTHER CONTAINERS MAY HAVE A TOTAL INSIDE HEIGHT OF 95", BUT A CLEAR HEIGHT UNDER THE ROOF BOWS OF 93". VERIFY INSIDE CONTAINER HEIGHT PRIOR TO FABRICATING DUNNAGE. THE LOAD IS DESIGNED FOR TRAILER/CONTAINER-ON-FLATCAR (T/COFC) SHIPMENT, HOWEVER, THE LOAD AS DESIGNED CAN ALSO BE MOVED BY OTHER SURFACE MODES OF TRANSPORT. **NOTICE:** OTHER CONTAINERS OF THE SAME DESIGN CONFIGURATION CAN BE USED.
- D. WHEN LOADING PALLET UNITS, THEY ARE TO BE POSITIONED SO AS TO ACHIEVE A TIGHT LOAD (TIGHT AGAINST THE DUNNAGE ASSEMBLIES). THE UNBLOCKED SPACE ACROSS THE WIDTH OF A LOAD BAY IS NOT TO EXCEED 1-1/2". EXCESSIVE SLACK CAN BE ELIMINATED FROM A LOAD BY LAMINATING ADDITIONAL PIECES OF APPROPRIATE THICKNESS TO THE LONGITUDINAL PIECES ON THE CENTER FILL ASSEMBLIES. NAIL EACH ADDITIONAL PIECE W/ APPROPRIATELY SIZED NAIL EVERY 12". ADDITIONALLY, THE THICKNESS OF THE PIECES IN THE CENTER FILL ASSEMBLIES MAY BE ADJUSTED AS REQUIRED TO FACILITATE VARIANCE IN THE SIZE OF THE PALLET UNIT.
- E. DUNNAGE LUMBER SPECIFIED IS OF NOMINAL SIZE. FOR EXAMPLE, 1" X 4" MATERIAL IS ACTUALLY 3/4" THICK BY 3-1/2" WIDE AND 2" X 6" MATERIAL IS ACTUALLY 1-1/2" THICK BY 5-1/2" WIDE.
- F. A STAGGERED NAILING PATTERN WILL BE USED WHENEVER POSSIBLE WHEN NAILS ARE DRIVEN INTO JOINTS OF DUNNAGE ASSEMBLIES OR WHEN LAMINATING DUNNAGE. ADDITIONALLY, THE NAILING PATTERN FOR AN UPPER PIECE OF LAMINATED DUNNAGE WILL BE ADJUSTED AS REQUIRED SO THAT A NAIL FOR THAT PIECE WILL NOT BE DRIVEN THROUGH ONTO OR RIGHT BESIDE A NAIL IN A LOWER PIECE.
- G. IN SOME CONTAINERS THERE IS A SLOT AT THE CORNERS OF THE FORWARD WALL. PIECES OF DUNNAGE MATERIAL MUST BE LAMINATED TO THE BUFFER PIECES ON THE FORWARD BLOCKING ASSEMBLY TO PROVIDE A FLAT SURFACE FOR THE BUFFER PIECES. A PIECE OF 2" X 4", 2" X 3" OR A SPECIAL WIDTH PIECE CUT-TO-FIT CAN BE USED. THIS FILL PIECE WILL BE NAILED WITH ONE APPROPRIATELY SIZED NAIL EVERY 12". NOTE THAT SOME CONTAINERS ARE EQUIPPED WITH "TIE-BARS" IN THE CORNER SLOT, WHICH PRECLUDE THE USE OF A FULL HEIGHT FILL PIECE. WHEN "TIE-BARS" ARE PRESENT, THE FILL PIECE MUST BE INSTALLED IN SEGMENTS DESIGNED TO FIT BETWEEN THE "TIE-BARS" VERTICALLY. THE FILL PIECE(S) IS NOT REQUIRED WHEN THE CORNER PORTIONS OF THE CONTAINER FORWARD WALL ARE SMOOTH AND FLAT. DO NOT ALLOW ANY DUNNAGE ASSEMBLY TO CONTACT THE CONTAINER FORWARD WALL, ONLY THE CORNER POSTS OF THE CONTAINER SHOULD BE USED FOR FORWARD LONGITUDINAL BLOCKING.
- H. WHETHER A CONTAINER IS FULL OR IS LOADED WITH A REDUCED QUANTITY OF LADING UNITS, THE LENGTHWISE CENTER OF GRAVITY OF THE LOAD MUST BE WITHIN 12", IN EITHER DIRECTION, OF THE MID-POINT OF THE CONTAINER.
- J. **CAUTION:** DO NOT NAIL DUNNAGE MATERIAL TO THE CONTAINER WALLS OR FLOOR. ALL NAILING WILL BE WITHIN THE DUNNAGE.
- K. PORTIONS OF THE CONTAINER DEPICTED WITHIN THIS DRAWING, SUCH AS THE SIDEWALL, HAVE NOT BEEN SHOWN IN THE LOAD VIEWS FOR CLARITY PURPOSES.
- L. **MAXIMUM LOAD WEIGHT CRITERIA:**
- THE MAXIMUM LOAD WEIGHTS ARE CONTROLLED BY EQUIPMENT CAPABILITY FACTORS. ALTHOUGH THE HEAVIEST MAXIMUM LOADS ARE DELINEATED IN THE LOAD VIEWS, PROVISIONS ARE INCLUDED WITHIN THIS DRAWING SO THAT THE BASIC LOADS CAN BE ADJUSTED TO SATISFY A LESSER QUANTITY OF LADING UNITS. DEPENDING ON TRANSPORTATION ROUTING, IT MAY BE NECESSARY TO REDUCE THE LOAD WEIGHT TO SATISFY "WEIGHT LAWS" OF CERTAIN STATES. ALSO, IT MAY BE NECESSARY TO REDUCE THE LOAD WEIGHT TO SATISFY OTHER WEIGHT RESTRICTIONS IMPOSED ON THE INTERMODAL CONTAINER SYSTEM.
- M. REQUIREMENTS CITED WITHIN THE ASSOCIATION OF AMERICAN RAILROADS (AAR) INTERMODAL LOADING GUIDE APPLY WHEN THE SHIPMENT MOVES BY TRAILER/CONTAINER-ON-FLATCAR (T/COFC). SPECIAL T/COFC NOTES FOLLOW:
1. A LOADED CONTAINER MUST BE ON A CHASSIS EQUIPPED WITH TWO BOGIE ASSEMBLIES WHEN BEING MOVED IN TOFC SERVICE.
 2. THE LOAD LIMIT OF A T/COFC RAILCAR MUST NOT BE EXCEEDED, NOR WILL A CAR BE LOADED SO THAT THE TRUCK UNDER ONE END OF THE CAR CARRIES MORE THAN ONE-HALF OF THE LOAD LIMIT FOR THAT CAR.

(CONTINUED AT RIGHT)

(GENERAL NOTES CONTINUED)

- N. DURING INTRASTATE AND/OR INTERSTATE MOVES BY MOTOR CARRIER, A PROPER CHASSIS OR MODIFIED FLATBED TRAILER MUST BE USED TO PRECLUDE VIOLATION OF ONE OR MORE "WEIGHT LAWS" APPLICABLE TO THE STATE OR STATES INVOLVED.
- O. CONVERSION TO METRIC EQUIVALENTS: DIMENSIONS WITHIN THIS DOCUMENT ARE EXPRESSED IN INCHES AND WEIGHTS ARE EXPRESSED IN POUNDS. WHEN NECESSARY, THE METRIC EQUIVALENTS MAY BE COMPUTED ON THE BASIS OF ONE INCH EQUALS 25.4MM AND ONE POUND EQUALS 0.454 KG.
- P. THE QUANTITY OF PALLET UNITS SHOWN IN THE LOAD ON PAGE 2 MAY BE REDUCED FOR SHIPMENT, IF DESIRED. SEE THE "LESS THAN FULL LOAD PROCEDURE" ON PAGE 8.
1. IF A LOAD IS REDUCED BY ONLY A SMALL AMOUNT (ONE, TWO OR THREE LADING UNITS), LADING UNITS NORMALLY MAY BE ELIMINATED FROM THE CENTER OF THE LOAD.
 2. IF A LOAD IS REDUCED BY A LARGE AMOUNT (MORE THAN THREE LADING UNITS), LADING UNITS SHOULD BE ELIMINATED AS REQUIRED AND THE TOTAL LOAD SHIFTED FORE OR AFT, AS NECESSARY, TO ACHIEVE A SYMMETRICAL WEIGHT DISTRIBUTION. THE DEPICTED PROCEDURES WILL BE FOLLOWED AS CLOSELY AS POSSIBLE, MAKING ONLY THOSE ADJUSTMENTS TO THE DUNNAGE WHICH ARE REQUIRED TO ACCOMMODATE THE NUMBER OF UNITS TO BE SHIPPED.
- Q. SIX UNIVERSAL LOAD RETAINERS, AS DEPICTED IN THE LOADS ON PAGE 2 AND 8, ARE REQUIRED WHEN LOADING TWO-HIGH LOADS, AND FOUR ARE REQUIRED WHEN LOADING ONE-HIGH LOADS. REFER TO DAC DRAWING ACV00682 FOR DETAILS OF THE UNIVERSAL LOAD RETAINER CONSTRUCTION, AND TO DEPARTMENT OF THE ARMY DRAWING DA-116 FOR DETAILS FOR INSTALLATION TO THE DOOR POST VERTICAL, PLACEMENT INTO THE CONTAINER, AND FOR OTHER METHODS OF REAR-OF-LOAD RESTRAINT.
- R. ANTI-CHAFING MATERIAL MAY BE ADDED BETWEEN PALLET UNITS OR BETWEEN PALLET UNITS AND THE END OPENING CONTAINER, IF DESIRED, TO PREVENT CHAFING DAMAGE TO THE PALLET UNIT.
- S. RECOMMENDED SEQUENTIAL LOADING PROCEDURES:
1. PREFABRICATE TWO FORWARD/REAR BLOCKING ASSEMBLIES, TWO CENTER FILL ASSEMBLIES (ONE THREE PALLET UNITS LONG AND ONE TWO PALLET UNITS LONG), AND TWO DOOR POST VERTICALS.
 2. INSTALL THE TWO VERTICAL PIECES TO THE FORWARD BLOCKING ASSEMBLY.
 3. INSTALL THE FORWARD BLOCKING ASSEMBLY.
 4. LOAD TWELVE PALLET UNITS.
 5. INSTALL ONE CENTER FILL ASSEMBLY.
 6. LOAD EIGHT PALLET UNITS.
 7. INSTALL ONE CENTER FILL ASSEMBLY.
 8. INSTALL THE REAR BLOCKING ASSEMBLY.
 9. INSTALL THE DOOR POST VERTICALS, UNIVERSAL LOAD RETAINERS, DOOR SPANNERS, AND FILLER PIECES.

REVISION

REVISION NO. 1, DATED NOVEMBER 2011, CONSISTS OF:
ADDING AN ALTERNATE LOADING PROCEDURE.

MATERIAL SPECIFICATIONS

- LUMBER** - - - - - : SEE TM 743-200-1 (DUNNAGE LUMBER) AND VOLUNTARY PRODUCT STANDARD PS 20.
- NAILS** - - - - - : ASTM F1667; COMMON STEEL NAIL (NLCMS OR NLCMMS).
- PLYWOOD** - - - - - : COMMERCIAL ITEM DESCRIPTION A-A-55057, INDUSTRIAL PLYWOOD, INTERIOR WITH EXTERIOR GLUE, GRADE C-D. IF SPECIFIED GRADE IS NOT AVAILABLE, A BETTER INTERIOR OR AN EXTERIOR GRADE MAY BE SUBSTITUTED.
- WIRE, CARBON STEEL** - - - - - : ASTM A853; ANNEALED AT FINISH, BLACK OXIDE FINISH, 0.0800" DIA, GRADE 1006 OR BETTER.
- ANTI-CHAFING MATERIAL** - - - - - : MIL-PRF-121 (OR EQUAL); NEUTRAL BARRIER MATERIAL.
- STEEL, STRUCTURAL** - - - - - : ASTM A36; 36,000 PSI MINIMUM YIELD OR BETTER.

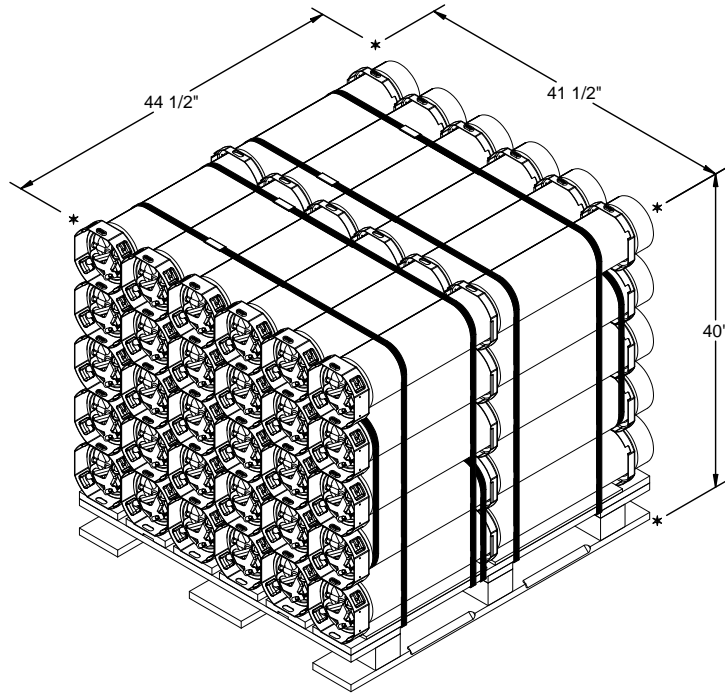

PALLET UNIT

GROSS WEIGHT - - - - - 1,804 LBS (APPROX)
 CUBE - - - - - 42.8 CU FT (APPROX)

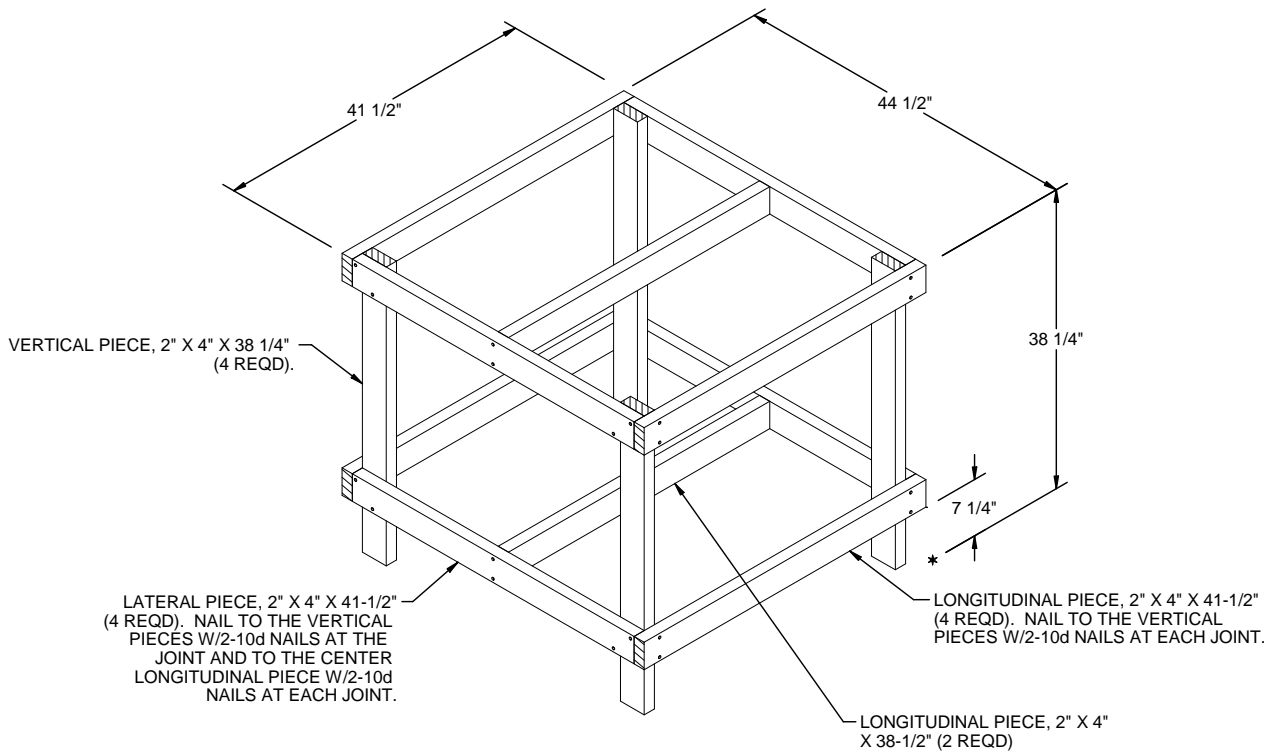

FILLER ASSEMBLY

FOR MINUS ONE PALLET UNIT

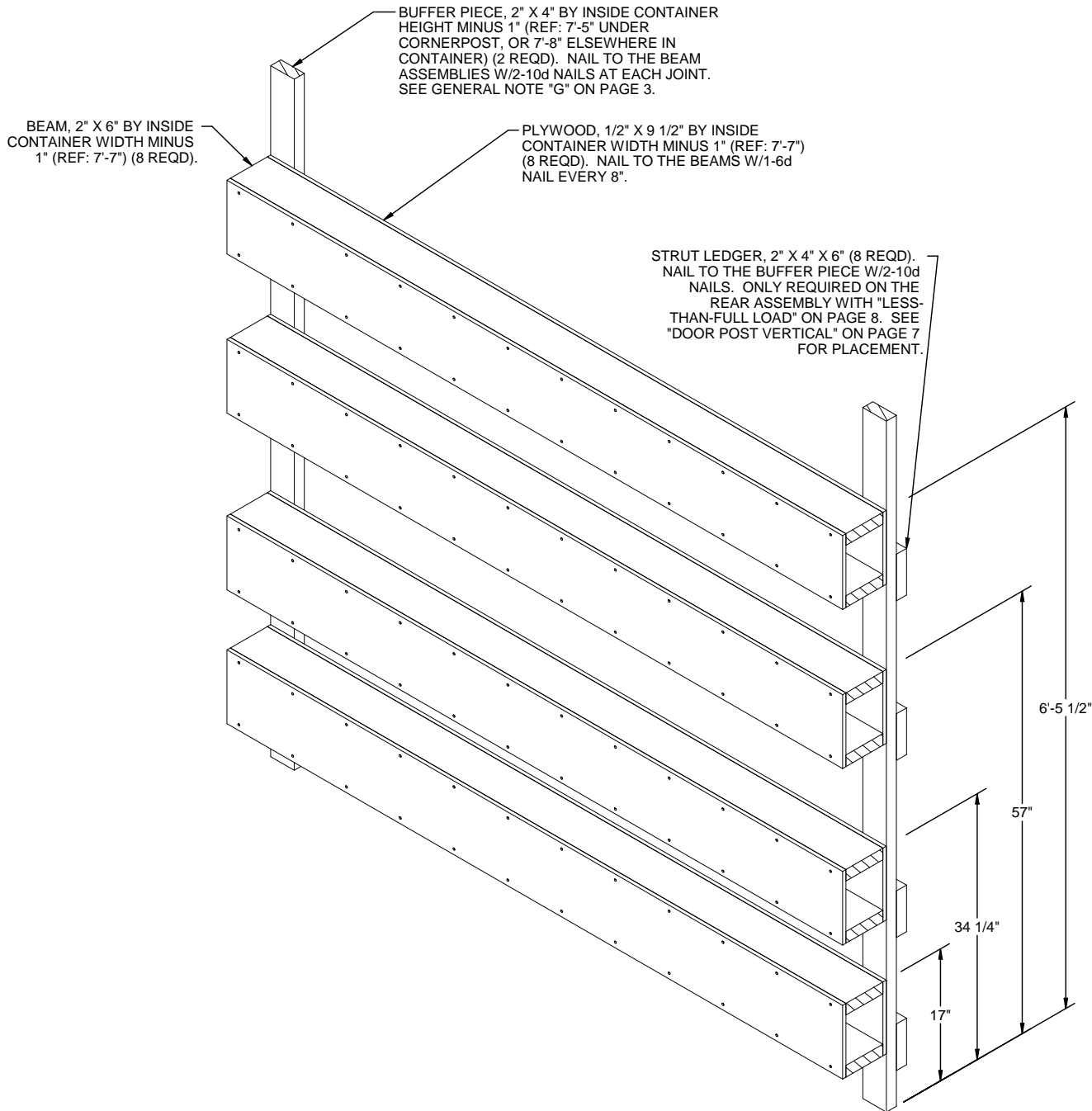

FORWARD/REAR BLOCKING ASSEMBLY

NOTE: FOR A ONE LAYER LOAD, ELIMINATE THE TOP TWO BEAM ASSEMBLIES.

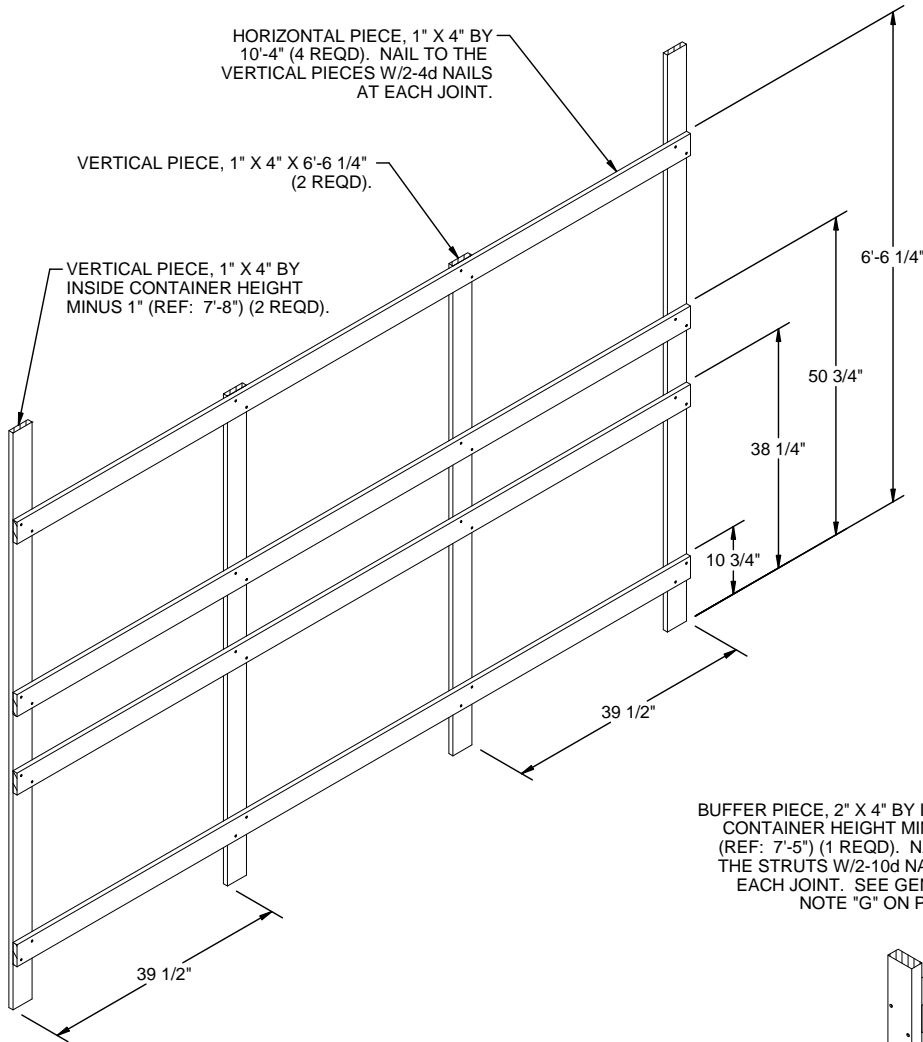

CENTER FILL ASSEMBLY

NOTE: THE ASSEMBLY DEPICTED ABOVE IS FOR USE IN A THREE PALLET UNIT LONG, TWO PALLET UNIT HIGH LOAD BAY. FOR A ONE HIGH LOAD, ELIMINATE THE TOP TWO HORIZONTAL PIECES AND REDUCE THE HEIGHT OF INNER VERTICAL PIECE(S) TO 45". FOR A TWO PALLET UNIT LONG LOAD BAY, ELIMINATE ONE INNER VERTICAL PIECE, AND REDUCE THE LENGTH OF THE HORIZONTAL PIECES TO 6'-10 1/2". FOR A ONE PALLET UNIT LONG LOAD BAY, ELIMINATE BOTH INNER VERTICAL PIECES, AND REDUCE THE LENGTH OF THE HORIZONTAL PIECES TO 41".

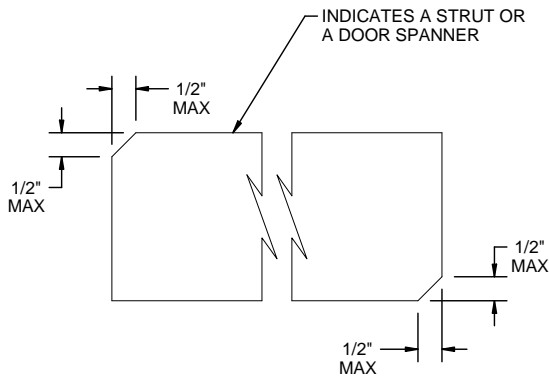

BEVEL CUT

IF DESIRED, EACH END OF A STRUT OR DOOR SPANNER MAY BE BEVEL-CUT AS SHOWN ABOVE TO FACILITATE INSTALLING THE STRUTS OR DOOR SPANNERS WITH A "DRIVE" FIT.

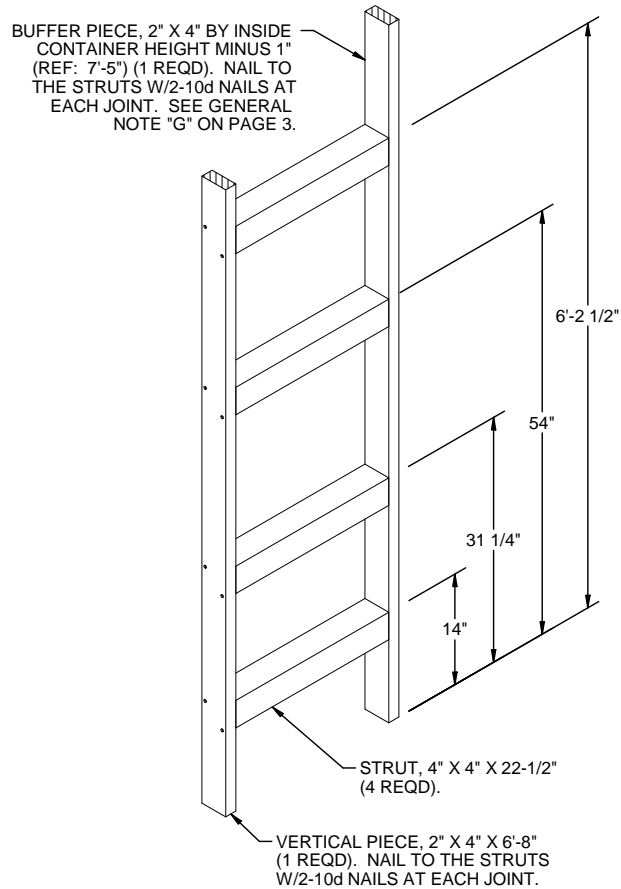

STRUT ASSEMBLY

NOTE: FOR A ONE HIGH LOAD, ELIMINATE THE TOP TWO STRUTS. REDUCE THE HEIGHT OF THE VERTICAL PIECE FROM 6'-8" TO 37".

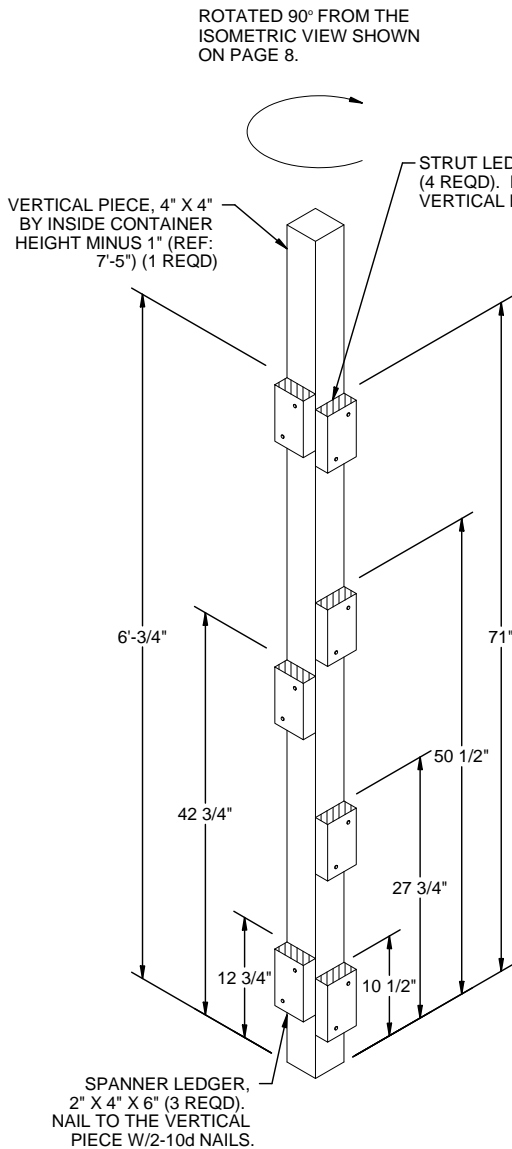

DOOR POST VERTICAL

A LEFT-HAND ASSEMBLY IS DEPICTED ABOVE, A RIGHT-HAND ASSEMBLY IS ALSO REQUIRED. FOR A ONE HIGH LOAD ELIMINATE THE TOP TWO STRUT LEDGERS AND THE TOP DOOR SPANNER LEDGER.

NOTE: THE STRUT LEDGERS ARE REQUIRED ONLY FOR THE "LESS-THAN-FULL LOAD PROCEDURE" ON PAGE 8.

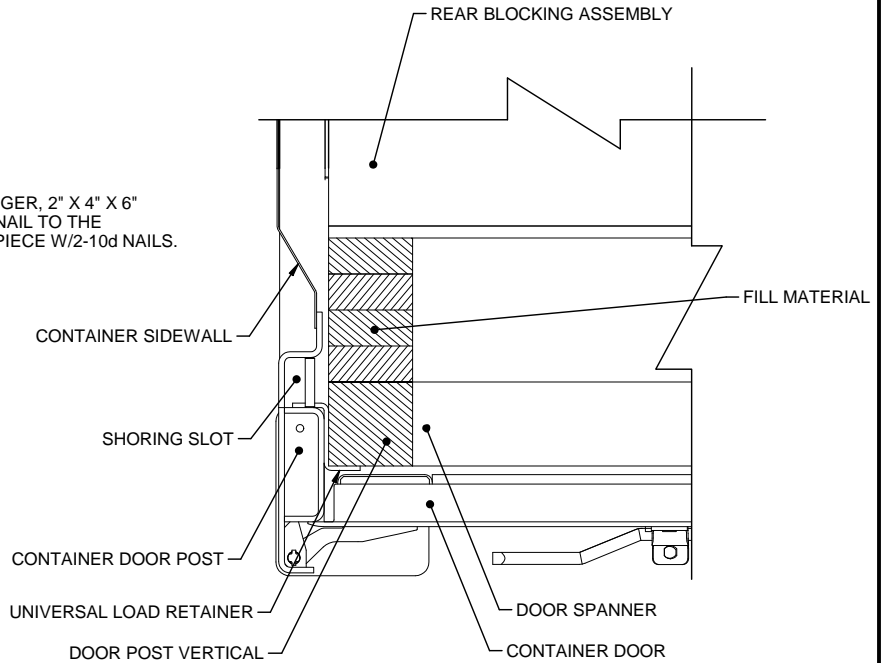

DETAIL A

A PARTIAL PLAN VIEW OF THE LEFT REAR PORTION OF THE CONTAINER ON PAGE 2 IS SHOWN DEPICTING THE PROPER POSITION OF THE DOOR POST VERTICAL, UNIVERSAL LOAD RETAINER, AND ADJACENT DUNNAGE PIECES.

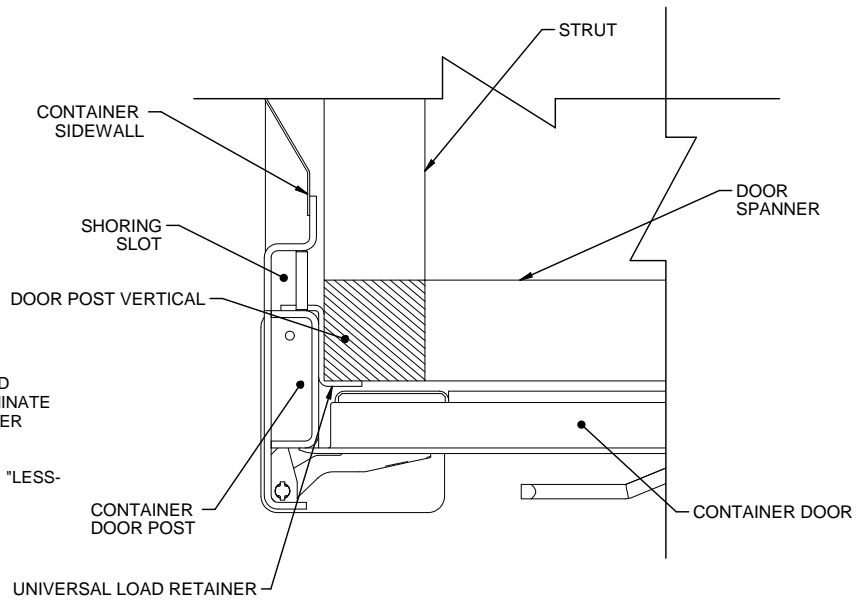

DETAIL B

A PARTIAL PLAN VIEW OF THE LEFT REAR PORTION OF THE CONTAINER ON PAGE 8 IS SHOWN DEPICTING THE PROPER POSITION OF THE DOOR POST VERTICAL, UNIVERSAL LOAD RETAINER, AND ADJACENT DUNNAGE PIECES.

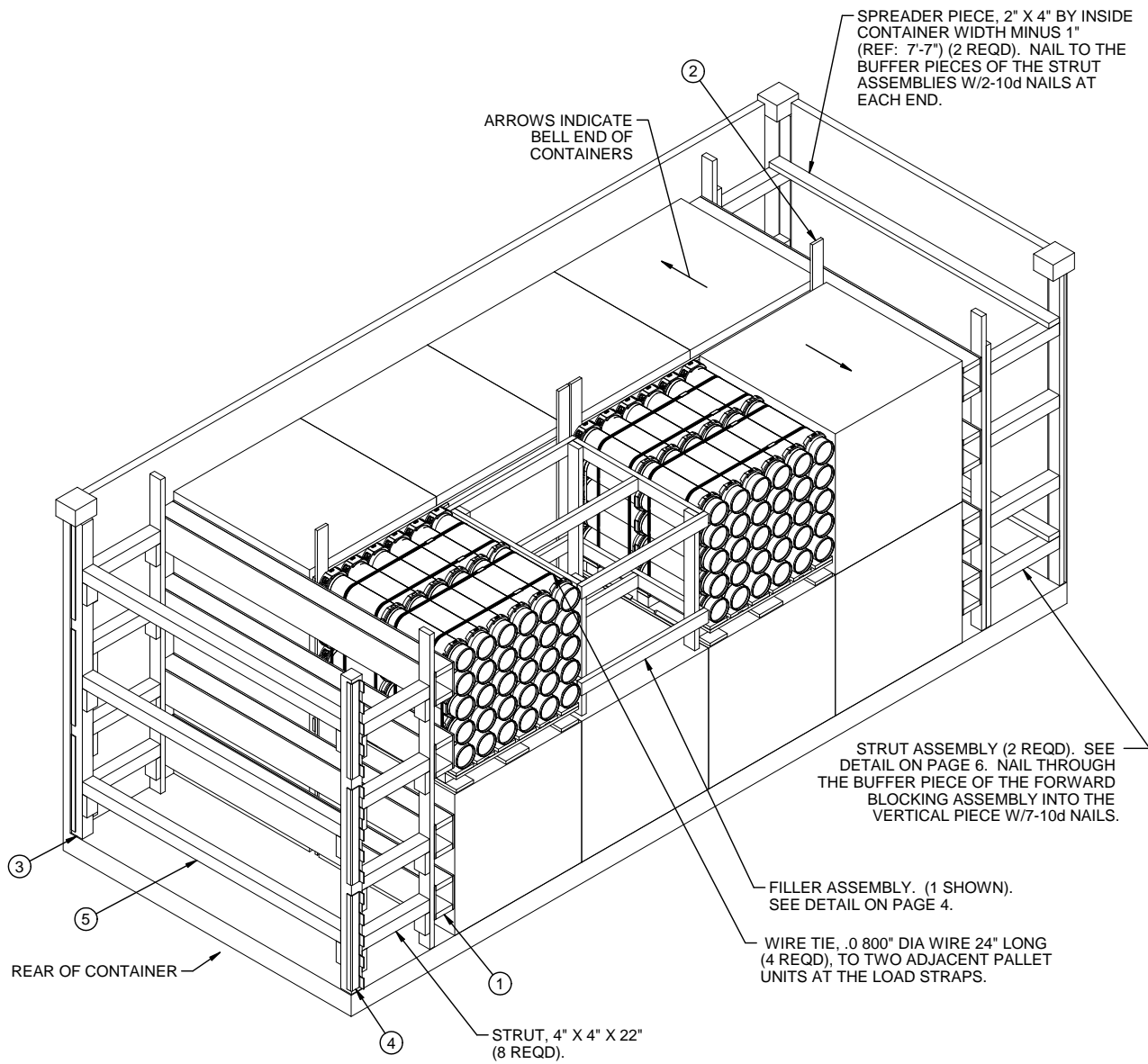

LESS-THAN-FULL LOAD PROCEDURE

KEY NUMBERS REFER TO THE KEY NUMBERS ON PAGE 2.
SEE GENERAL NOTES "H" AND "P" ON PAGE 3.