

APPROVED BY U.S. COAST GUARD <i>M.D. M...th</i> DATE <u>6/12/86</u>	APPROVED BY BUREAU OF EXPLOSIVES <i>f. W. Heshman</i> SUPERVISOR, MILITARY & INTERMODAL SERVICES DATE <u>4/29/86</u>
--	--

LOADING AND BRACING^① IN MILVAN CONTAINERS[⊕] OF COMPLETE ROUNDS PACKED IN PA98 CYLINDRICAL METAL CONTAINERS

- ① LOADING AND BRACING SPECIFICATIONS SET FORTH WITHIN THIS DRAWING ARE APPLICABLE TO LOADS THAT ARE TO BE SHIPPED BY TRAILER/CONTAINER-ON-FLAT-CAR (T/COFC) RAIL CARRIER SERVICE. THESE SPECIFICATIONS MAY ALSO BE USED FOR LOADS THAT ARE TO BE MOVED BY MOTOR OR WATER CARRIER. SEE GENERAL NOTE "M" ON PAGE 3.
- ⊕ ONLY MILVAN CONTAINERS WHICH HAVE BEEN MODIFIED TO INCLUDE A MECHANICAL LOAD-BRACING SYSTEM THAT SATISFIES THE REQUIREMENTS OF THE BUREAU OF EXPLOSIVES PAMPHLET 6C WILL BE USED FOR THE MOVEMENT OF AMMUNITION BY T/COFC SERVICE. CAUTION: OTHER REQUIREMENTS OF PAMPHLET 6C ALSO APPLY.

<u>ITEM</u>	<u>INDEX</u>	<u>PAGE (S)</u>
TYPICAL LOADING PROCEDURE -----		2
GENERAL NOTES & MATERIAL SPECIFICATIONS-----		3
PALLET UNIT DETAILS -----		4
DETAILS-----		4-6
ALTERNATIVE LOADING PROCEDURE-----		5

DO NOT SCALE

REVISIONS		DRAFTSMAN	PROJ. ENG.
		<i>dh</i>	<i>LDF/WRF</i>
		CHECKER <i>GRG</i>	LOG. ENG. OFFICE <i>W.F. Ernst</i>
APPROVED, U.S. ARMY ARMAMENT, MUNITIONS AND CHEMICAL COMMAND <i>B. J. Jackson</i>			
APPROVED BY ORDER OF COMMANDING GENERAL, U.S. ARMY MATERIEL COMMAND (AMC) <i>William S. Ernst</i> U.S. ARMY DEFENSE AMMUNITION CENTER AND SCHOOL			
U.S. ARMY AMC DRAWING			
JUNE 1986			
CLASS	DIVISION	DRAWING	FILE
19	48	4214/5	15PM 1006

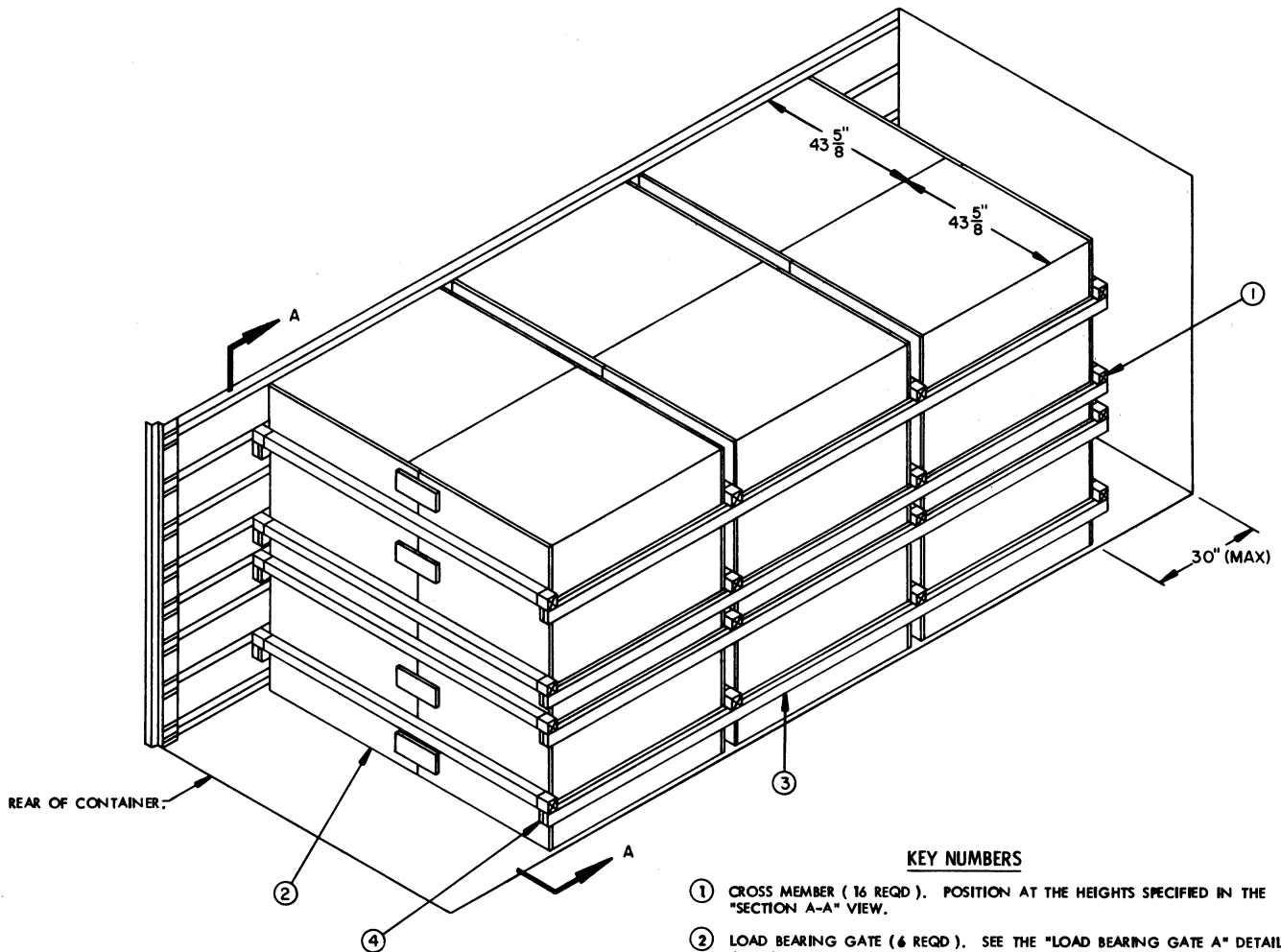

KEY NUMBERS

- ① CROSS MEMBER (16 REQD). POSITION AT THE HEIGHTS SPECIFIED IN THE "SECTION A-A" VIEW.
- ② LOAD BEARING GATE (6 REQD). SEE THE "LOAD BEARING GATE A" DETAIL ON PAGE 5.
- ③ SIDE FILL, 2" X 4" BY LADING LENGTH (8 REQD). INSTALLATION MAY BE MADE FROM RANDOM LENGTH PIECES. WITH THE SIDE FILL, PIECE MARKED ④, WIRE TIE TO THE 16", 38", 48", AND 72" HIGH BELT RAILS ON EACH SIDE OF THE CONTAINER. SEE THE "SIDE FILL" DETAIL ON PAGE 5 AND GENERAL NOTE "N" ON PAGE 3.
- ④ SIDE FILL, 1" X 4" BY LADING LENGTH (8 REQD). LAMINATE TO SIDE FILL, PIECE MARKED ③, W/1-6d NAIL EVERY 12", THEN WIRE TIE TO THE 16", 38", 48", AND 72" HIGH BELT RAILS ON EACH SIDE OF THE CONTAINER. INSTALLATION MAY BE MADE FROM RANDOM LENGTH PIECES. SEE THE "SIDE FILL" DETAIL ON PAGE 5 AND GENERAL NOTE "N" ON PAGE 3.

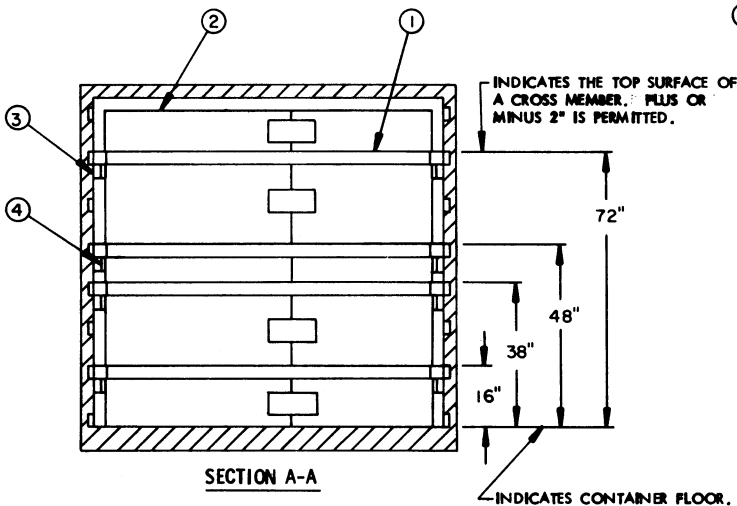

(GENERAL NOTES CONTINUED)

GENERAL NOTES

K. TO MAKE LOADING EASIER, TO HELP ACHIEVE A TIGHT LOAD ACROSS A CONTAINER, AND TO PREVENT UNACCEPTABLE DAMAGE TO LADING UNITS WHEN LOADING A MILVAN, A SLIP-SHEET CAN BE USED EFFECTIVELY AS A "SHOE-HORN" TYPE DEVICE. THE SLIP-SHEET WILL PROVIDE A SMOOTH SURFACE THAT WILL PREVENT UNIT STRAPS AND/OR CONTAINERS FROM INTERLOCKING OR CATCHING ON OTHER PROJECTIONS WHEN LATERALLY ADJACENT LADING UNITS ARE BEING LOADED. A SLIP-SHEET WILL BE USED AFTER ONE-HALF OF A STACK IS LOADED WITH ONE OF ITS SIDES IN TIGHT CONTACT AT ONE SIDE OF THE MILVAN. THE SLIP-SHEET IS TO BE PLACED AGAINST THE OTHER SIDE OF THE HALF-STACK BEFORE THE LAST HALF OF THE STACK IS LOADED. AFTER A STACK IS COMPLETED, THE SLIP-SHEET IS TO BE REMOVED FOR SUBSEQUENT USE WITH THE NEXT STACK. A SLIP-SHEET OF SUITABLE SIZE CAN BE MADE FROM A SHEET OF 1/8" TEMPERED HARDBOARD (MASONITE) OR FROM A SHEET OF ANY OTHER MATERIAL THAT WILL SATISFY THE REQUIREMENTS.

L. MAXIMUM LOAD WEIGHT CRITERIA:

THE ITEMIZED LOAD WEIGHTS ARE CONTROLLED BY EQUIPMENT CAPABILITY FACTORS. ALSO, THESE LISTED LOAD WEIGHTS IDENTIFY THE COMBINED WEIGHT OF AMMUNITION LADING UNITS AND DUNNAGE THAT CAN BE PLACED INTO ONE MILVAN CONTAINER WITHOUT VIOLATING ONE OR MORE OF THE "CAPABILITY FACTORS". SEE NOTES 1 AND 2.

39,100 LBS IN 20-FT CONTAINER (W/O CHASSIS) ABOARD CONTAINERSHIP.
39,100 LBS IN CONTAINER ON 20-FT CHASSIS WITH DOUBLE BOGIE. SEE NOTE 3.
25,300 LBS IN CONTAINER ON 20-FT CHASSIS WITH SINGLE BOGIE. SEE NOTE 4.
21,300 LBS IN EACH CONTAINER ON 40-FT CHASSIS (COUPLED WITH DOUBLE BOGIE). SEE NOTE 3.

NOTE 1: DUNNAGE INCLUDES MATERIALS, OTHER THAN COMPONENTS OF THE MECHANICAL LOAD-BRACING SYSTEM, USED TO BLOCK AND BRACE A LOAD.

NOTE 2: ALTHOUGH THE HEAVIEST MAXIMUM LOADS ARE DELINEATED IN THE LOAD VIEWS, PROVISIONS ARE INCLUDED WITHIN THIS DRAWING SO THAT THE BASIC LOADS CAN BE ADJUSTED TO SATISFY A LESSER QUANTITY OF LADING UNITS.

NOTE 3: DEPENDING ON TRANSPORTATION ROUTING, IT MAY BE NECESSARY TO REDUCE THE LOAD WEIGHT TO SATISFY "WEIGHT LAWS" OF CERTAIN STATES. ALSO, IT MAY BE NECESSARY TO REDUCE THE LOAD WEIGHT TO SATISFY OTHER WEIGHT RESTRICTIONS IMPOSED ON THE MILVAN SYSTEM.

NOTE 4: BY SPECIAL AUTHORITY, IT MAY BE POSSIBLE TO MOVE HEAVIER LOADS ON SINGLE BOGIE CHASSIS WITHIN AN INSTALLATION.

M. SPECIAL T/COFC NOTES:

1. CAUTION: LOADED CONTAINERS MUST BE ON CHASSIS EQUIPPED WITH TWO BOGIE ASSEMBLIES WHEN BEING MOVED IN TOFC SERVICE, REGARDLESS OF LOAD WEIGHT WITHIN THE CONTAINERS.

2. LOAD LIMITS OF T/COFC RAIL CARS MUST NOT BE EXCEEDED, NOR WILL A CAR BE LOADED SO THAT THE TRUCK UNDER ONE END OF THE CAR CARRIES MORE THAN ONE-HALF OF THE LOAD LIMIT FOR THAT CAR.

3. CHASSIS/CONTAINERS COUPLED INTO A 40-FOOT TRAILER CONFIGURATION MUST BE PLACED AT THE B-END OF A TOFC RAIL CAR. THE REAR END OF THE 40-FOOT UNIT WILL OVERHANG THE END OF THE CAR IF IT IS PLACED AT THE A-END. TWENTY-FOOT AND 40-FOOT UNITS CAN BE LOADED ON THE SAME CAR.

N. THE THICKNESS OF THE SIDE FILL PIECES AS DEPICTED ON EACH SIDE OF THE LOAD MUST BE ADJUSTED, AS REQUIRED TO COMPLY WITH THE DIMENSIONAL VARIANCE OF THE PALLET UNIT, SO AS TO NOT ALLOW MORE THAN ONE AND ONE-HALF INCH (1-1/2") VOID ACROSS THE WIDTH OF A BRACED LOAD. ADJUSTMENTS CAN BE MADE BY USING A DIFFERENT THICKNESS FILL PIECE OR BY LAMINATING ADDITIONAL PIECES TO THE SPECIFIED FILL PIECES ON ONE OR BOTH SIDES OF THE LOAD.

- A. THIS DOCUMENT HAS BEEN PREPARED AND ISSUED IN ACCORDANCE WITH AR 740-1 AND AUGMENTS TM 743-200-1 (CHAPTER 5).
- B. THE OUTLOADING PROCEDURE SPECIFIED HEREIN IS APPLICABLE TO PALLETIZED UNITS OF COMPLETE ROUNDS PACKED IN PA98 SERIES CYLINDRICAL METAL CONTAINERS. SUBSEQUENT REFERENCE TO PALLET UNIT MEANS THE PALLETIZED UNIT WITH AMMUNITION ITEMS. SEE PAGE 4 OF THIS DRAWING AND U.S. AMC DRAWING NO. 19-48-4079/5-20PM1002 FOR DETAIL OF THE PALLETIZED UNIT. CAUTION: REGARDLESS OF THE QUANTITY OF UNITS TO BE SHIPPED, THE "MAXIMUM GROSS WEIGHT" OF 44,800 POUNDS MUST NOT BE EXCEEDED.
- C. THE LOADS AS SHOWN ARE BASED ON A 20' LONG BY 8' WIDE BY 8' HIGH MILVAN CONTAINER WITH INSIDE DIMENSIONS OF 19'-4" LONG BY 92" WIDE BY 87" HIGH. THE LOADS ARE DESIGNED FOR TRAILER/CONTAINER-ON-FLAT-CAR (T/COFC) SHIPMENT.
- D. THE SPECIFIED OUTLOADING PROCEDURES ARE FOR CONTAINERS EQUIPPED WITH SELF-CONTAINED MECHANICAL BRACING DEVICES AS DESCRIBED WITHIN BUREAU OF EXPLOSIVES PAMPHLET 6C. CROSS MEMBER ATTACHMENT FACILITIES WITHIN THESE CONTAINERS MUST PROVIDE FOR THE INSTALLATION OF LOAD BLOCKING CROSS MEMBERS AT THE HEIGHTS SPECIFIED. THE HEIGHT DIMENSIONS SPECIFIED WITHIN THIS DRAWING FOR THE INSTALLATION OF CROSS MEMBERS CONFORM WITH BUREAU OF EXPLOSIVES PAMPHLET 6C, WITH THE EXCEPTION THAT TWO (2) ADDITIONAL BELT RAILS HAVE BEEN SHOWN: ONE AT 72" AND ONE AT 88" HIGH FROM THE CONTAINER FLOOR. VOIDS LENGTHWISE WITHIN THE LOAD MUST BE HELD TO A MINIMUM. CROSS MEMBERS MUST BE PLACED AGAINST THE LADING AS TIGHTLY AS THE HOLE SPACING IN THE CROSS MEMBER ATTACHMENT FACILITY PERMITS. EACH CROSS MEMBER WILL BE INSTALLED WITH THE ENDS ATTACHED AS NEARLY AS POSSIBLE IN "MATED" POSITIONS (AT EQUAL HEIGHTS AND AT EQUAL DISTANCES FROM THE END OF THE CONTAINER). CROSS MEMBERS IN EMPTY CONTAINERS AND THOSE NOT USED IN LOADED CONTAINERS MUST BE FASTENED INTO BELT RAILS FOR SHIPMENT. COMPONENTS ASSIGNED TO EACH CONTAINER MUST REMAIN THEREWITH EVEN THOUGH UNUSED DURING SOME SHIPMENTS. SEE THE "FILL DETAIL" ON PAGE 4 FOR THE DUNNAGING METHOD REQUIRED TO ELIMINATE AN EXCESSIVE LENGTHWISE VOID WITHIN A LOAD. THE LOAD BLOCKING COMPONENT DESIGNATED AS "CROSS MEMBER" HEREIN, IS IDENTIFIED AS "BEAM ASSEMBLY" WITHIN TM 55-8115-200-23 & P, DATED DECEMBER 1979. THE BEAM ASSEMBLY IS FURTHER IDENTIFIED AS NSN 8115-00-165-6623 (FSN 8115-165-6623).
- E. DUNNAGE LUMBER SPECIFIED IS OF A NOMINAL SIZE. FOR EXAMPLE, 1" X 4" MATERIAL IS ACTUALLY 3/4" THICK BY 3-1/2" WIDE AND 2" X 6" MATERIAL IS ACTUALLY 1-1/2" THICK BY 5-1/2" WIDE.
- F. CAUTION: DO NOT NAIL DUNNAGE MATERIAL TO THE CONTAINER WALLS OR FLOOR. ALL NAILING WILL BE WITHIN THE DUNNAGE.
- G. A STAGGERED NAILING PATTERN WILL BE USED WHEREVER POSSIBLE WHEN NAILS ARE DRIVEN INTO JOINTS OF DUNNAGE ASSEMBLIES OR WHEN LAMINATING DUNNAGE. ADDITIONALLY, THE NAILING PATTERN FOR AN UPPER PIECE OF LAMINATED DUNNAGE WILL BE ADJUSTED AS REQUIRED SO THAT A NAIL FOR THAT PIECE WILL NOT BE DRIVEN THROUGH ONTO OR RIGHT BESIDE A NAIL IN A LOWER PIECE.
- H. PORTIONS OF THE CONTAINER DEPICTED WITHIN THIS DRAWING, SUCH AS ONE OF THE SIDEWALLS, HAVE NOT BEEN SHOWN IN THE LOAD VIEWS FOR CLARITY PURPOSES.
- J. CONVERSION TO METRIC EQUIVALENTS: DIMENSIONS WITHIN THIS DOCUMENT ARE EXPRESSED IN INCHES, AND WEIGHTS ARE EXPRESSED IN POUNDS. WHEN NECESSARY, THE METRIC EQUIVALENTS MAY BE COMPUTED ON THE BASIS OF ONE INCH EQUALS 25.4MM AND ONE POUND EQUALS 0.454KG.

(CONTINUED AT LEFT)

BILL OF MATERIAL		
LUMBER	LINEAR FEET	BOARD FEET
1" X 4"	115	39
1" X 6"	24	12
2" X 4"	115	77
NAILS	NO. REQD	POUNDS
6d (2")	256	1-1/2
10d (3")	32	1/2
WIRE, NO. 14 GAGE	60' REQD	1 LB
PLYWOOD, 1/2"	301 SQ FT REQD	414 LBS
CROSS MEMBER		16 REQD

MATERIAL SPECIFICATIONS

LUMBER: SEE TM 743-200-1, DUNNAGE LUMBER: FED SPEC MM-L-751.

NAILS: FED SPEC FF-N-105; COMMON.

WIRE: FED SPEC QQ-W-461.

STAPLE, STRAP: COMMERCIAL GRADE.

PLYWOOD: GROUP B, CONSTRUCTION AND INDUSTRIAL PLYWOOD, INTERIOR WITH EXTERIOR GLUE, GRADE C-D, IF SPECIFIED GRADE IS NOT AVAILABLE, A BETTER INTERIOR OR AN EXTERIOR GRADE MAY BE SUBSTITUTED; FED SPEC MM-P-530.

LOAD AS SHOWN

ITEM	QUANTITY	WEIGHT (APPROX)
PALLET UNIT	12	33,540 LBS
DUNNAGE		673 LBS
CONTAINER		5,700 LBS
TOTAL WEIGHT		39,913 LBS

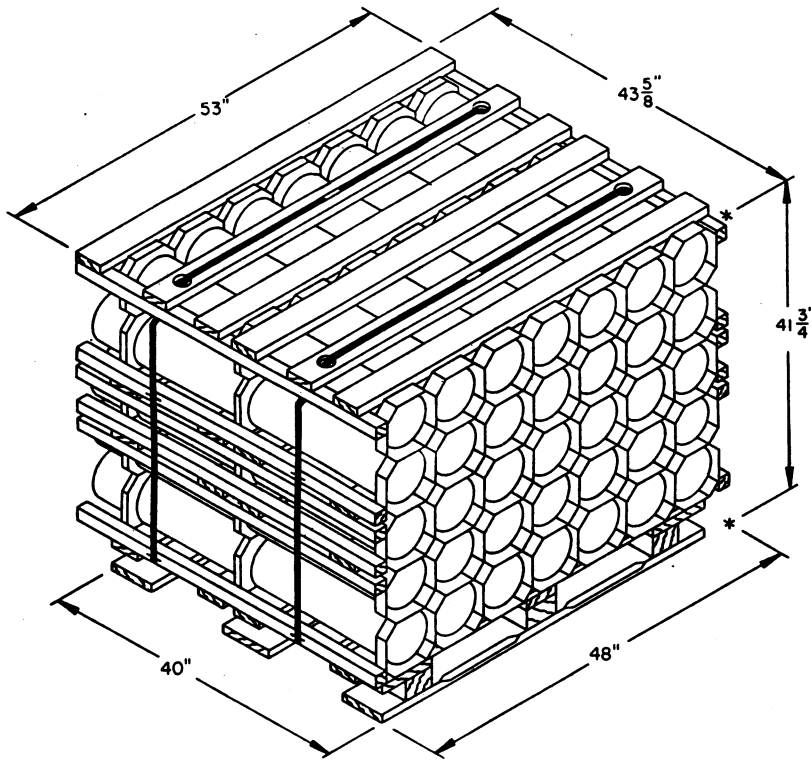

PALLET UNIT

UNIT WEIGHT-----2,795 LBS (APPROX)
 CUBE-----55.9 CU FT

RETAINER PIECE, 2" X 4" BY CUT-TO-FIT IN LENGTH (2 REQD). NAIL TO THE STRUTS W/1-10d NAIL AT EACH JOINT AND TO THE BUFFER PIECE W/4-10d NAILS.

FABRICATE TO FIT BETWEEN CONTAINER SIDE WALL AND PALLET UNIT.

STRUT, 2" X 4" BY CUT-TO-FIT IN LENGTH (2 REQD).

BUFFER PIECE, 2" X 4" BY CUT-TO-FIT IN LENGTH (2 REQD). NAIL TO THE STRUTS W/2-10d NAILS AT EACH JOINT.

FABRICATE TO FIT BETWEEN INSTALLED CROSS MEMBERS.

FILL MATERIAL, 1" X 4" OR 2" X 4" MATERIAL BY CONTAINER WIDTH MINUS 1" (AS REQD).

TIE WIRE, NO. 14 GAGE WIRE 18" LONG (3 REQD/CROSS MEMBER). INSTALL TO FORM A COMPLETE LOOP AROUND FILL MATERIAL AND CROSS MEMBER. BRING THE ENDS TOGETHER AND TWIST TAUT. SECURE TO THE FILL MATERIAL WITH A PARTIALLY DRIVEN 10d NAIL BENT OVER THE WIRE, OR WITH A STRAP STAPLE.

INDICATES CROSS MEMBER.

SPACER ASSEMBLY

FILL DETAIL

THIS DETAIL DEPICTS METHOD OF POSITIONING FILL MATERIAL BETWEEN CROSS MEMBER AND LADING, WHEN THE VOID BETWEEN THE TWO IS GREATER THAN ONE INCH (1") FOR LONGITUDINAL BRACING.

TIE WIRE, NO. 14 GAGE WIRE 18" LONG (16 REQD). INSTALL TO FORM A COMPLETE LOOP AROUND CROSS MEMBER AND SPACER ASSEMBLY, BRING ENDS TOGETHER AND TWIST TAUT. SECURE TO THE SPACER ASSEMBLY WITH A PARTIALLY DRIVEN 10d NAIL BENT OVER THE WIRE, OR WITH A STRAP STAPLE.

LOAD BEARING GATE (2 REQD). SEE THE "LOAD BEARING GATE C" DETAIL ON PAGE 6.

LOAD BEARING GATE (2 REQD). SEE THE "LOAD BEARING GATE B" DETAIL ON PAGE 6.

SPACER ASSEMBLY (4 REQD). SEE THE "SPACER ASSEMBLY" DETAIL ON PAGE 4.

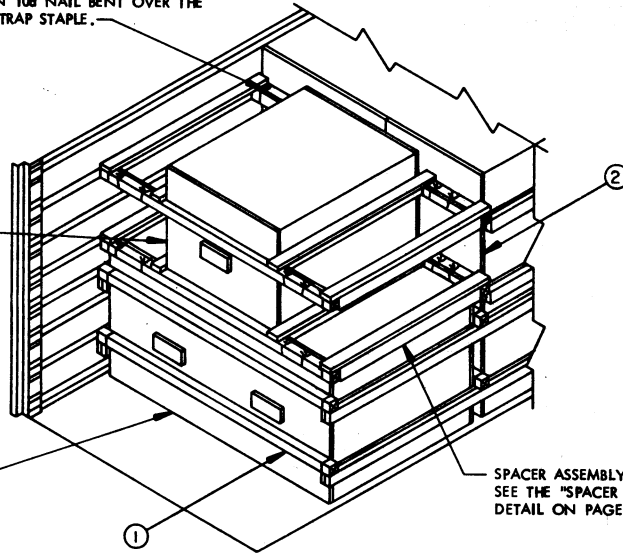

ALTERNATIVE LOADING PATTERN

THE DETAIL ABOVE DEPICTS A BLOCKING METHOD TO BE USED IN A "REDUCED LOAD" CONTAINER LOAD.

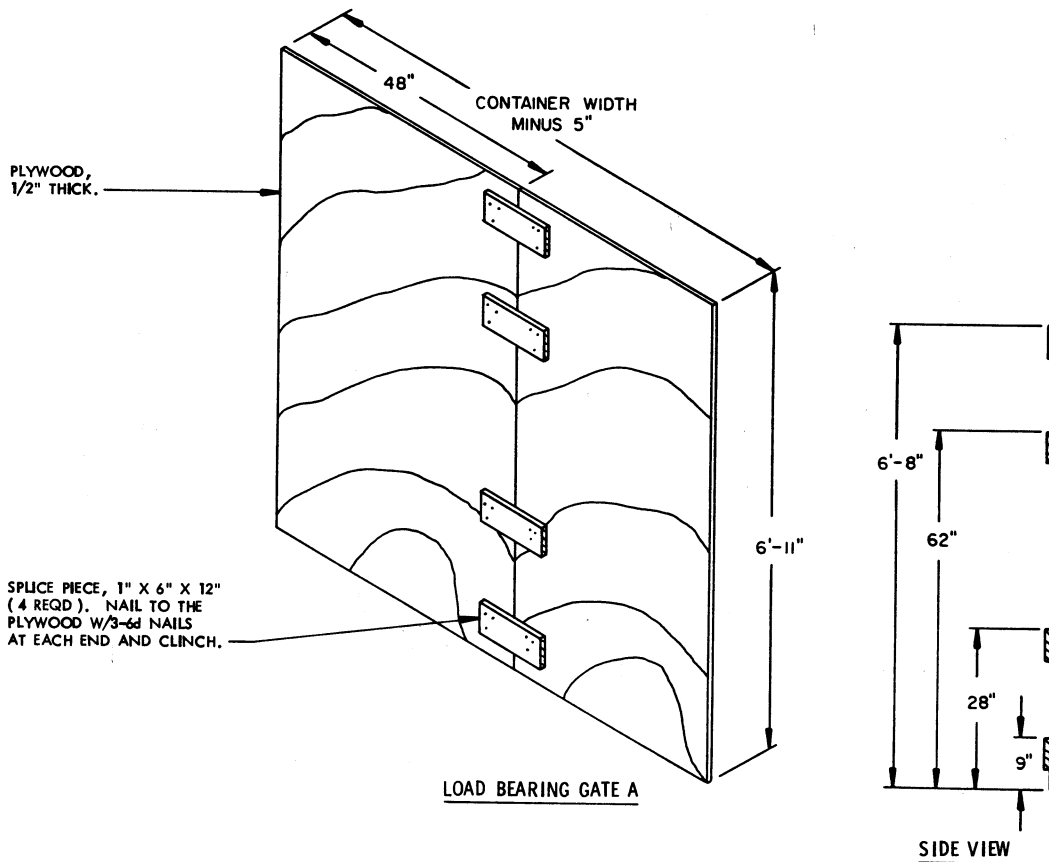

PLYWOOD, 1/2" THICK.

SPLICE PIECE, 1" X 6" X 12" (4 REQD). NAIL TO THE PLYWOOD W/3-6d NAILS AT EACH END AND CLINCH.

LOAD BEARING GATE A

SIDE VIEW

TIE WIRE, NO. 14 GAGE WIRE 18" LONG. WIRE TO FORM A COMPLETE LOOP THRU HOLE IN BELT RAIL AND AROUND FILL PIECE, BRING ENDS TOGETHER AND TWIST TAUT. REQUIRED NEAR EACH END OF FILL PIECE AND EVERY 48" OF FILL PIECE LENGTH AS SHOWN.

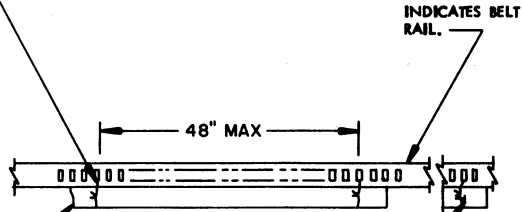

SIDE FILL DETAIL

FILL PIECE, 1" AND 2" X 4" BY LADING LENGTH, RANDOM LENGTH PIECES MAY BE USED (8 REQD). REQUIRED AT THE 16", 38", 48", AND 72" HIGH BELT RAILS.

RETAINER NAIL. PARTIALLY DRIVEN 10d NAIL BENT OVER THE WIRE TO PREVENT LONGITUDINAL MOVEMENT OF FILL PIECES (1 REQD NEAR EACH END OF EACH LENGTH OF SIDE FILL PIECE). A STRAP STAPLE MAY BE USED IN LIEU OF A RETAINER NAIL.

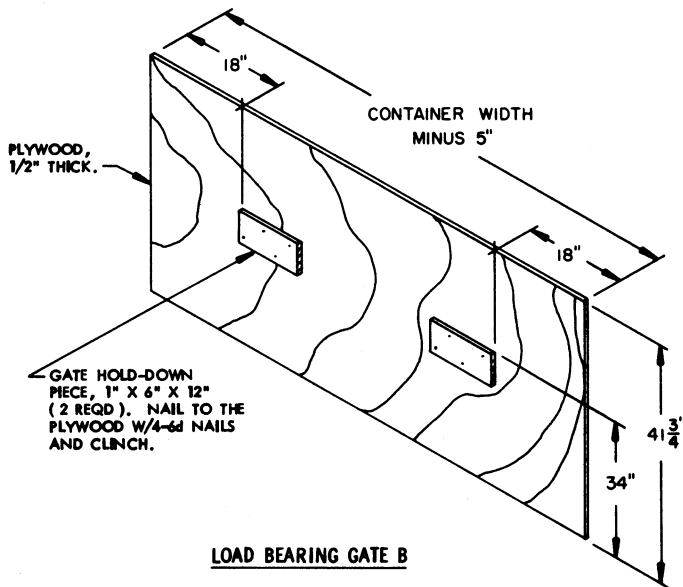

LOAD BEARING GATE B

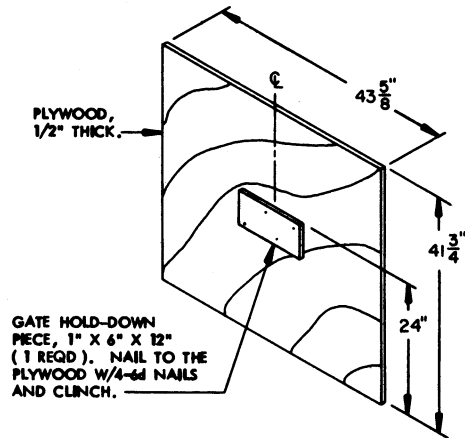

LOAD BEARING GATE C