

# LOADING AND BRACING (TL & LTL) IN CLOSED OR OPEN TOP VAN TRAILERS OF COMPLETE ROUNDS PACKED IN CYLINDRICAL METAL CONTAINERS AND UNITIZED ON A 35" X 45-1/2" WOODEN PALLET

## MI52 SERIES CONTAINER

### INDEX

<u>ITEM</u>	<u>PAGE (S)</u>
GENERAL NOTES AND MATERIAL SPECIFICATIONS-----	2
PALLET UNIT DETAIL-----	3
TYPICAL FULL LOAD PROCEDURES-----	4-9
TYPICAL LTL PROCEDURES-----	10-13
PROCEDURES FOR SHIPMENT OF LEFTOVER CONTAINERS-----	14
PROCEDURES FOR SHIPMENT OF PARTIAL PALLET UNIT-----	15
DETAILS-----	16-19
PROCEDURES FOR CONVENTIONAL VAN TRAILERS EQUIPPED WITH ROLL-UP TYPE DOORS-----	20, 21
PROCEDURES FOR CONVENTIONAL VAN TRAILERS EQUIPPED WITH LARGE-ANGLED CORNERS-----	22

THIS DOCUMENT INCLUDES OUTLOADING PROCEDURES FOR CONVENTIONAL TYPE TRAILERS AND FOR TRAILERS EQUIPPED WITH MECHANICAL BRACING DEVICES AS APPROVED BY THE BUREAU OF EXPLOSIVES, ASSOCIATION OF AMERICAN RAILROADS. CAUTION: THE PROCEDURES SHOWN HEREIN, FOR BOTH TYPES OF TRAILERS, ARE ONLY APPLICABLE FOR HIGHWAY MOVEMENTS; NOT FOR TRAILER-ON-FLAT-CAR MOVEMENTS.

**DO NOT SCALE**

REVISIONS		DRAWN	TYPE	CHECKER	TECHNICIAN	ENGINEER
		<i>Dew</i>	PT	<i>PJE</i>	<i>PB</i>	
				SMCAC-DEV	SMCAC-DEG	SMCAC-DE
				APPROVED BY ORDER OF COMMANDER GENERAL, U.S. ARMY MATERIEL COMMAND		
				<i>William L. Bryant</i> MATERIEL COMMAND (AMC)		
				U.S. ARMY DEFENSE AMMUNITION CENTER AND SCHOOL		
				U.S. ARMY MATERIEL COMMAND		
				FEBRUARY 1990		
				CLASS	DIVISION	DRAWING
				19	48	4213/4
						FILE
						11PM 1003

GENERAL NOTES

(GENERAL NOTES CONTINUED)

- A. THIS DOCUMENT HAS BEEN PREPARED AND ISSUED IN ACCORDANCE WITH AR 740-1, AND AUGMENTS TM 43-200-1 (CHAPTER 5).
- B. THE OUTLOADING PROCEDURES SPECIFIED IN THIS DRAWING ARE APPLICABLE FOR THE M152 COMPLETE ROUND CONTAINER ASSEMBLED ON THE 35" X 45-1/2" 4-WAY ENTRY PALLET. SEE THE PICTORIAL VIEW ON PAGE 3 FOR SIZE AND WEIGHT. REFER TO U.S. ARMY AMC DRAWING 19-48-4079/4-20PM1002 FOR UNITIZATION PROCEDURES FOR THE M152 SERIES CONTAINERS.
- C. THE OUTLOADING PROCEDURES DEPICTED WITHIN THIS DOCUMENT ARE APPLICABLE FOR SHIPMENTS IN CONVENTIONAL TYPE VAN TRAILERS, AND FOR SHIPMENTS IN VAN TRAILERS EQUIPPED WITH VARIOUS TYPES OF SELF-CONTAINED MECHANICAL BRACING DEVICES (CROSS MEMBERS AND WALL MEMBERS) AND APPLY TO TRAILERS HAVING WOOD, OR WOOD AND METAL, OR ALL METAL FLOORS. VAN TRAILERS WHICH ARE 40'-0" LONG BY 7'-6" TO 7'-8-1/2" WIDE (INSIDE DIMENSION) HAVE BEEN SHOWN, HOWEVER, THE PROCEDURES ARE ALSO APPLICABLE FOR TRAILERS WHICH ARE EIGHTY-NINE INCHES (89") THRU NINETY-NINE INCHES (99") IN WIDTH AND FOR TRAILERS OF OTHER LENGTHS FROM THE SHORTEST TO THE LONGEST AVAILABLE (REF: 24' TO 53'), AND FOR STRAIGHT TRUCK VANS. THE LOADING AND BRACING PROCEDURES SPECIFIED HEREIN ARE ALSO ADEQUATE (CONFIGURATION WISE AND STRENGTH WISE) FOR LOADS IN SHORTER OR LONGER VANS AND IN NARROWER OR WIDER VANS THAN SHOWN. THE SPECIFIED BRACING IS ADEQUATE FOR LOADS WEIGHING UP TO AND INCLUDING THE MAXIMUM WEIGHTS PERMITTED BY LAW.
- D. THE OUTLOADING PROCEDURES DEPICTED WITHIN THIS DOCUMENT FOR TRAILERS EQUIPPED WITH VARIOUS TYPES OF SELF-CONTAINED MECHANICAL BRACING DEVICES ARE LIMITED TO HIGHWAY MOVEMENTS ONLY. THE HEIGHT REQUIREMENTS SPECIFIED WITHIN THIS DRAWING FOR THE INSTALLATION OF CROSS MEMBERS ARE IDENTICAL WITH THOSE RECOMMENDED BY THE BUREAU OF EXPLOSIVES PAMPHLET 6C, AND APPENDICES THERETO. CAUTION: TRAILERS EQUIPPED WITH WALL MEMBERS WHICH DO NOT MEET THE LOCATION REQUIREMENTS MUST NOT BE USED.
  - 1. PALLET UNITS SHOULD BE LOADED TIGHTLY AGAINST EACH OTHER AND/OR AGAINST INSTALLED CROSS MEMBERS. Voids LENGTHWISE WITHIN A LOAD SHOULD BE MINIMUM. CROSS MEMBERS MUST BE PLACED AGAINST THE LADING AS TIGHTLY AS THE WALL MEMBER LOCKING HOLE SPACING PERMITS. EACH CROSS MEMBER WILL BE INSTALLED WITH EACH END ATTACHED AS NEARLY AS POSSIBLE IN A "MATED" POSITION (AT EQUAL HEIGHTS, AND AT EQUAL DISTANCES FROM THE END OF THE TRAILER).
  - 2. CROSS MEMBERS IN EMPTY TRAILERS AND THOSE UNUSED IN LOADED TRAILERS MUST BE "SECURED" FOR SHIPMENT. COMPONENTS ASSIGNED TO EACH TRAILER MUST REMAIN THERewith EVEN THOUGH UNUSED DURING SOME SHIPMENTS.
  - 3. ONE (1) CROSS MEMBER WILL BE REQUIRED FOR EACH 10,000 POUNDS OF LADING AND SHOULD NOT BE RELIED UPON TO RETAIN A GREATER WEIGHT. CROSS MEMBERS WILL NOT BE DOUBLED, THAT IS, TWO CROSS MEMBERS AT THE SAME HEIGHT LOCATION WILL NOT BE PLACED SIDE BY SIDE.
- E. SELECTION OF A VEHICLE TO BE USED TO TRANSPORT THE DESIGNATED ITEM MUST COMPLY WITH AR 55-255, CHAPTER 29, FOR EXPLOSIVES AND OTHER DANGEROUS ARTICLES, IN FULL.
- F. THE GROSS WEIGHT AND AXLE DISTRIBUTION OF WEIGHT FOR A LOAD WILL BE THE RESPONSIBILITY OF THE CARRIER. THE CARRIER WILL ADVISE THE SHIPPER OF THE APPLICABLE LOADING REQUIREMENTS, AND THE SHIPPER WILL LOAD ACCORDINGLY. THE TOTAL WEIGHT OF THE LADING, OF THE DUNNAGE, OF THE TRACTOR, AND OF THE SEMI-TRAILER CARRYING THE LADING MUST NOT EXCEED THE MAXIMUM GROSS WEIGHT ALLOWED FOR THE STATE OR STATES THRU WHICH THE LOAD IS TO BE TRANSPORTED BY MOTOR CARRIER. LIKEWISE, THE GROSS WEIGHT ON A SINGLE OR TANDEM AXLE MUST NOT EXCEED THE MAXIMUM ALLOWABLE WEIGHT. IF THERE IS ANY DOUBT AS TO WHETHER THE TOTAL GROSS WEIGHT OR AXLE WEIGHT EXCEEDS THE MAXIMUM ALLOWED, WEIGHT SHOULD BE VERIFIED BY ACTUALLY WEIGHING THE LOADED VEHICLE.

- G. NOTICE: A SHIPMENT WILL BE POSITIONED IN THE TRAILER CONSISTENT WITH STATE WEIGHT LAWS. THE NUMBER OF LADING UNITS MAY BE ADJUSTED TO FIT THE SIZE OF THE TRAILER TO BE LOADED OR THE QUANTITY TO BE SHIPPED. COMBINATIONS OF THE OUTLOADING PROCEDURES SPECIFIED MAY BE USED; HOWEVER, THE APPROVED METHODS SHOWN MUST BE FOLLOWED AS CLOSELY AS POSSIBLE FOR BLOCKING, BRACING, AND STAYING OF THE DESIGNATED ITEMS.
- H. THE "LOAD AS SHOWN" FOR MOST OF THE FULL LOADS DEPICTED HEREIN IS BASED ON AN APPROXIMATE LADING WEIGHT OF 42,000 POUNDS. THE SPECIFIED BLOCKING AND BRACING FOR THE FULL LOADS IS ADEQUATE FOR THE RETENTION OF HEAVIER LOADS, IF IT IS DESIRED TO INCREASE THE LADING WEIGHT.
- J. OTHER TYPES OF LADING ITEMS MAY BE LOADED INTO TRAILERS WHICH ARE PARTIALLY LOADED WITH PALLET UNITS OF COMPLETE ROUNDS, PROVIDING THE TOTAL LOAD IS COMPATIBLE, EXISTING DIRECTIVES ARE NOT VIOLATED, AND THE OTHER LADING ITEMS ARE BLOCKED AND BRACED TO EQUAL THE BLOCKING AND BRACING CRITERIA SPECIFIED HEREIN.
- K. SOME LOADS ARE SHOWN IN TRAILERS HAVING ROUNDED CORNERS AT THE FORWARD END. IF THE CONVENTIONAL VAN TRAILER BEING USED IS EQUIPPED WITH A SQUARE FRONT OR WITH AN INSTALLED BULKHEAD, OMIT THE FORWARD BLOCKING ASSEMBLY, PIECE-MARKED (1), AND POSITION THE PALLET UNITS DIRECTLY AGAINST THE FORWARD PORTION OF THE TRAILER; OMIT CROSS MEMBERS IN THE FORWARD END OF MECHANICAL VAN TRAILERS HAVING A SQUARE FRONT.
- L. PALLET UNITS WHICH DO NOT CONTAIN A FULL QUANTITY OF ITEMS CAN BE TRANSPORTED. SEE THE "SHIPMENT OF A PARTIAL PALLET UNIT" DETAIL AND SPECIAL NOTES ON PAGE 15. FOR "SHIPMENT OF LEFTOVER CONTAINERS", SEE THE DETAILS AND SPECIAL NOTES ON PAGE 14.
- M. WHEN STEEL STRAPPING IS SEALED AT AN END-OVER-END LAP JOINT, A MINIMUM OF ONE (1) SEAL WITH TWO (2) PAIR OF NOTCHES WILL BE USED TO SEAL THE JOINT WHEN A NOTCH-TYPE SEALER IS BEING USED. A MINIMUM OF TWO (2) SEALS, BUTTED TOGETHER, WITH TWO (2) PAIR OF CRIMPS PER SEAL WILL BE USED TO SEAL THE JOINT WHEN A CRIMP-TYPE SEALER IS BEING USED. REFER TO THE "STRAP JOINT A" AND "STRAP JOINT B" DETAILS ON PAGE 3 FOR GUIDANCE.
- N. DUNNAGE LUMBER SPECIFIED THROUGHOUT THIS PROCEDURAL DRAWING IS OF NOMINAL SIZE. FOR EXAMPLE, 2" X 4" MATERIAL IS ACTUALLY 1-1/2" THICK BY 3-1/2" WIDE AND 2" X 6" MATERIAL IS ACTUALLY 1-1/2" THICK BY 5-1/2" WIDE.
- O. NOTICE: A STAGGERED NAILING PATTERN WILL BE USED WHEREVER POSSIBLE WHEN NAILS ARE DRIVEN INTO JOINTS OF DUNNAGE ASSEMBLIES. ALSO, A STAGGERED NAILING PATTERN WILL BE USED WHEN DUNNAGE IS NAILED TO THE FLOOR OF THE TRANSPORTING VEHICLE, OR WHEN LAMINATING DUNNAGE. THE NAILING PATTERN WILL BE ADJUSTED AS REQUIRED SO THAT A NAIL DOES NOT PENETRATE INTO OR NEAR A CRACK BETWEEN FLOOR BOARDS. ADDITIONALLY, THE NAILING PATTERN FOR AN UPPER PIECE OF LAMINATED DUNNAGE WILL BE ADJUSTED AS REQUIRED SO THAT A NAIL FOR THAT PIECE WILL NOT BE DRIVEN THROUGH, ON TO, OR RIGHT BESIDE A NAIL IN A LOWER PIECE.
- P. POWER DRIVEN STAPLES MAY BE USED AS ALTERNATIVE FASTENERS FOR NAILS WHEN CONSTRUCTING DUNNAGE ASSEMBLIES WHICH ARE TO BE USED IN THE DELINEATED TRAILER LOADS SHOWN THROUGHOUT THIS DRAWING. THE STAPLES TO BE USED MUST BE EQUAL IN LENGTH TO THE SPECIFIED NAIL SIZE AND MUST BE SUBSTITUTED ON A ONE STAPLE FOR ONE NAIL BASIS. STAPLES WHICH ARE 2-1/2" OR LESS IN LENGTH SHOULD BE IN ACCORDANCE WITH FEDERAL SPECIFICATION FF-N-105 AS NEARLY AS PRACTICABLE. STAPLES WHICH ARE LONGER THAN 2-1/2" WILL BE A COMMERCIAL GRADE, OF A QUALITY EQUIVALENT TO THOSE MANUFACTURED BY Senco PRODUCTS INCORPORATED. NOTE: STAPLES WILL NOT BE SUBSTITUTED FOR NAILS IN ANY LOAD RESTRAINING FLOOR DUNNAGE APPLICATION.
- Q. PORTIONS OF THE TRAILERS, SUCH AS SIDEWALLS, END WALLS, AND ROOFS, HAVE NOT BEEN SHOWN IN THE LOAD VIEWS FOR CLARITY PURPOSES.
- R. FOR ADDITIONAL GUIDANCE, ATTENTION IS DIRECTED TO THE "SPECIAL NOTES" SECTIONS WHICH ARE IMMEDIATELY ADJACENT TO THE DEPICTED OUTLOADING METHODS.
- S. CONVERSION TO METRIC EQUIVALENTS: DIMENSIONS WITHIN THIS DOCUMENT ARE EXPRESSED IN INCHES, AND WEIGHTS ARE EXPRESSED IN POUNDS. WHEN NECESSARY, THE METRIC EQUIVALENTS MAY BE COMPUTED ON THE BASIS OF ONE INCH EQUALS 25.4MM AND ONE POUND EQUALS 0.454KG.

(CONTINUED AT RIGHT)

MATERIAL SPECIFICATIONS

- LUMBER-----: SEE TM 743-200-1, DUNNAGE LUMBER; FED SPEC MM-L-751.
- NAILS-----: FED SPEC FF-N-105; COMMON.
- STRAPPING, STEEL-----: FED SPEC QQ-S-781, CLASS 1, TYPE I OR IV, HEAVY DUTY, FINISH A, B (GRADE 2), OR C.
- SEAL, STRAP-----: FED SPEC QQ-S-781, TYPE D, STYLE I, II, OR IV, CLASS H, FINISH A, B (GRADE 2), OR C.
- PLYWOOD-----: GROUP B, CONSTRUCTION AND INDUSTRIAL PLYWOOD, INTERIOR WITH EXTERIOR GLUE, GRADE C-D, FED SPEC NN-P-530. IF SPECIFIED GRADE IS NOT AVAILABLE, A BETTER INTERIOR OR AN EXTERIOR GRADE MAY BE SUBSTITUTED.
- WIRE-----: FED SPEC QQ-W-461.
- TYGARD-----: POLYESTER YARN, 1,100 POUNDS/INCH OF WIDTH STRENGTH.
- ADHESIVE-----: TYGARD ADHESIVE.

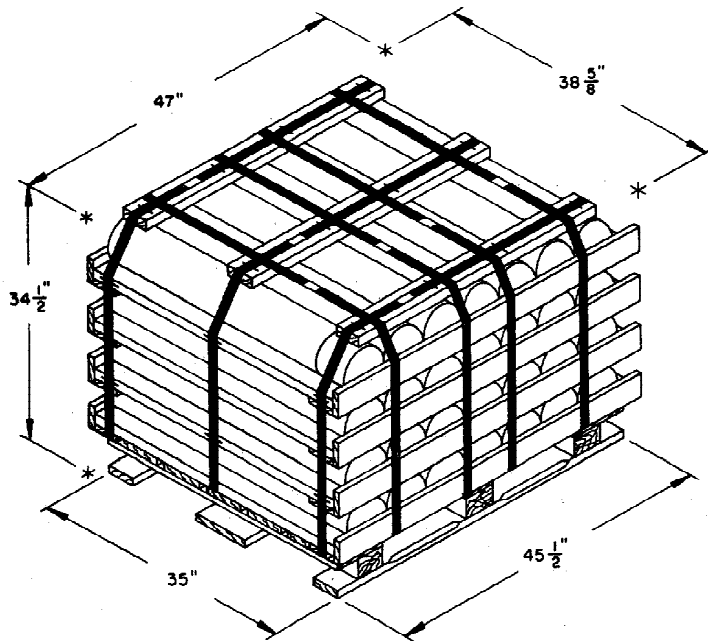

**PALLET UNIT**

CONTAINER-----28 EACH @ 71 LBS (APPROX)  
 CUBE-----36.2 CUBIC FEET (APPROX)  
 GROSS WEIGHT-----2,147 LBS (APPROX)



ONE SEAL WITH  
TWO PAIR OF  
NOTCHES.

**STRAP JOINT A**

METHOD OF SECURING A  
STRAP JOINT WHEN USING  
A NOTCH-TYPE SEALER.



TWO SEALS, BUTTED  
TOGETHER, WITH  
TWO PAIR OF CRIMPS  
EACH SEAL.

**STRAP JOINT B**

METHOD OF SECURING A  
STRAP JOINT WHEN USING  
A CRIMP-TYPE SEALER.

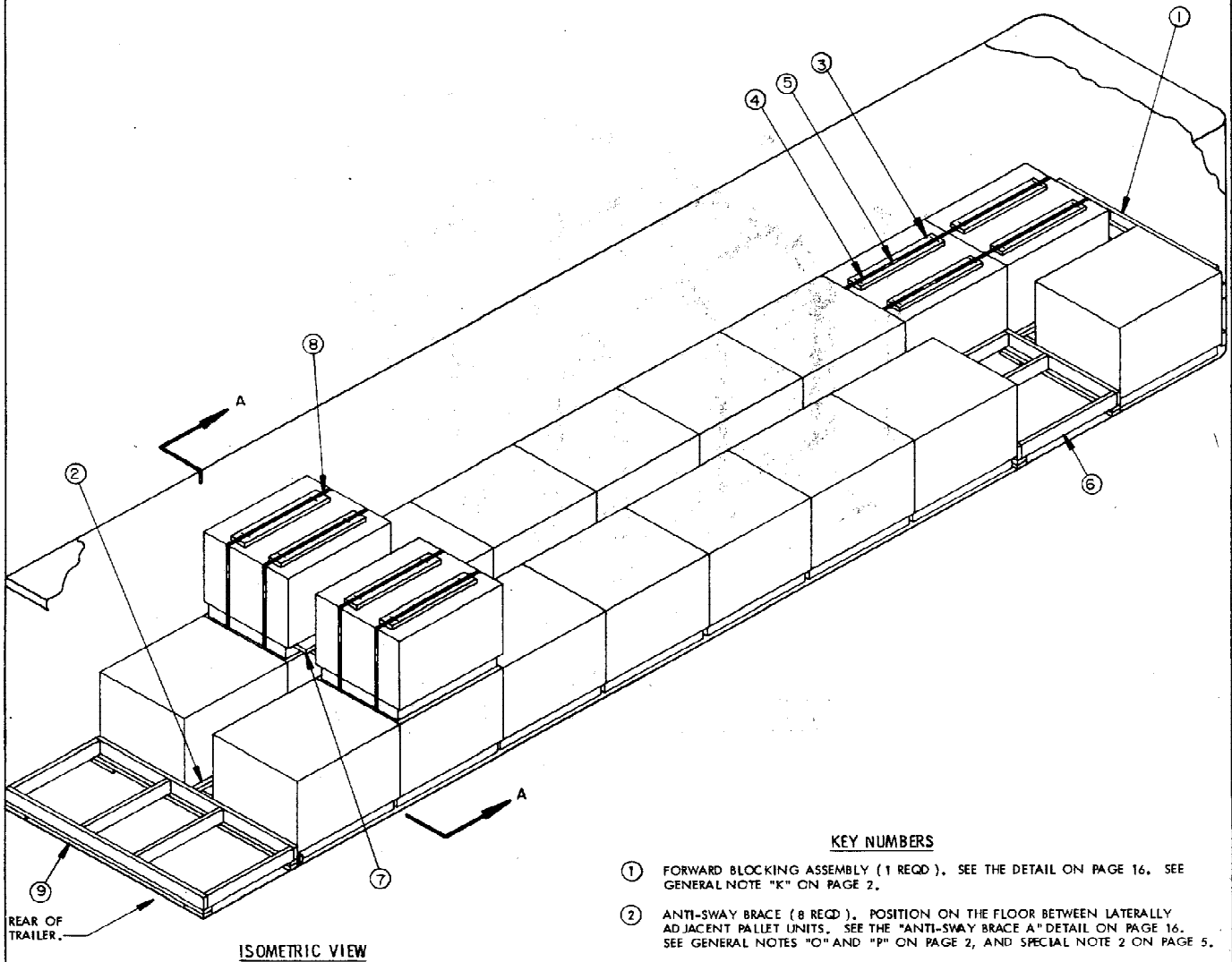

ISOMETRIC VIEW

**KEY NUMBERS**

- ① FORWARD BLOCKING ASSEMBLY (1 REQD). SEE THE DETAIL ON PAGE 16. SEE GENERAL NOTE "K" ON PAGE 2.
- ② ANTI-SWAY BRACE (8 REQD). POSITION ON THE FLOOR BETWEEN LATERALLY ADJACENT PALLET UNITS. SEE THE "ANTI-SWAY BRACE A" DETAIL ON PAGE 16. SEE GENERAL NOTES "O" AND "P" ON PAGE 2, AND SPECIAL NOTE 2 ON PAGE 5.
- ③ STRAPPING BOARD, 2" X 6" X 39" (8 REQD). PLACE UNDER THE TIEDOWN STRAPS ON THE UNIT. THESE STRAPPING BOARDS ONLY REQUIRED WHEN BUNDLING STRAPS OR UNITIZING STRAPS ARE TO BE USED.
- ④ BUNDLING STRAP, 1-1/4" X .035" OR .031" X 22'-6" LONG STEEL STRAPPING (2 REQD). INSTALL SO AS TO ENCIRCLE TWO (2) PALLET UNITS. SEE SPECIAL NOTE 3 ON PAGE 5.
- ⑤ SEAL FOR 1-1/4" STRAPPING (12 REQD, 2 PER STRAP). DOUBLE CRIMP EACH SEAL. SEE GENERAL NOTE "M" ON PAGE 2.
- ⑥ SPACER ASSEMBLY (1 REQD). SEE THE "SPACER ASSEMBLY A" DETAIL ON PAGE 16. SEE SPECIAL NOTE 4 ON PAGE 5.
- ⑦ ANTI-SWAY BRACE (1 REQD). SEE THE "ANTI-SWAY BRACE B" DETAIL ON PAGE 16. INSTALL BETWEEN LATERALLY ADJACENT PALLET UNITS IN THE SECOND STACK.
- ⑧ STACK UNITIZING STRAP, 1-1/4" X .035" OR .031" X 20'-6" LONG STEEL STRAPPING (4 REQD). INSTALL SO AS TO ENCIRCLE A TOP-LAYER PALLET UNIT AND THE UNIT DIRECTLY BELOW. SEE SPECIAL NOTE 5 ON PAGE 5.
- ⑨ REAR BLOCKING ASSEMBLY (1 REQD). SEE THE "REAR BLOCKING ASSEMBLY A" DETAIL ON PAGE 18. SEE SPECIAL NOTES 6 AND 10 ON PAGE 5.

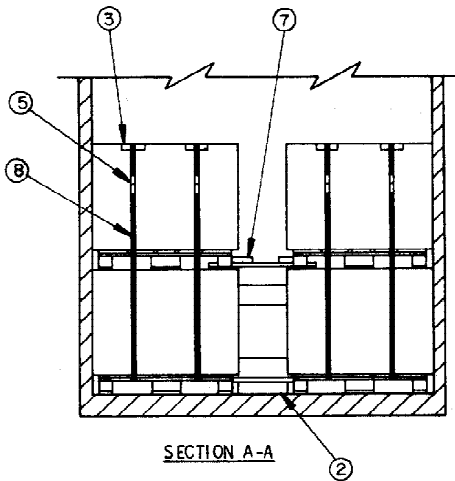

SECTION A-A

**SPECIAL NOTES:**

1. A 19-UNIT LOAD IS SHOWN IN A 40'-0" LONG BY 7'-6" WIDE (INSIDE DIMENSION) CONVENTIONAL TYPE VAN TRAILER. TRAILERS OF OTHER DIMENSIONS CAN BE USED. SEE SPECIAL NOTE 7.
2. ANTI-SWAY BRACES, SHOWN AS PIECES MARKED ② AND ⑦, IN THE LOAD ON PAGE 4 ARE TO BE POSITIONED BETWEEN ALL Laterally ADJACENT PALLET UNITS. IF SPACE PERMITS, ANTI-SWAY BRACE "B" SHOWN AS PIECE MARKED ② MAY BE USED THROUGHOUT THE LENGTH OF THE LOAD IN LIEU OF ANTI-SWAY BRACES "A", PIECE MARKED ⑦.
3. A PALLET UNIT THAT DOES NOT HAVE A PALLET UNIT DIRECTLY OPPOSITE MUST BE SECURED BY INSTALLING BUNDLING STRAPS, SHOWN AS PIECE MARKED ④ IN THE LOAD ON PAGE 4, AROUND THAT PALLET UNIT AND THE PALLET UNIT IMMEDIATELY ADJACENT.
4. THE SPACER ASSEMBLY SHOWN AS PIECE MARKED ⑥ IN THE LOAD VIEW, IS ONLY SHOWN TO DEPICT A TYPICAL INSTALLATION. IF A PALLET UNIT IS LOADED IN PLACE OF THE SPACER ASSEMBLY, BUNDLING STRAPS, PIECES MARKED ④ WILL NOT BE REQUIRED. NOTE THAT A SPACER ASSEMBLY MUST BE POSITIONED WHERE THERE WILL BE A PALLET UNIT AT EACH END; A SPACER ASSEMBLY MUST NOT BE POSITIONED ADJACENT TO THE FORWARD BLOCKING ASSEMBLY, PIECE MARKED ①.
5. A PALLET UNIT AT EACH END OF THE SECOND LAYER PORTION OF THE LOAD MUST BE UNITIZED TO A PALLET UNIT IN THE FIRST LAYER, UNLESS THE STACKED UNITS ARE AGAINST THE FRONT WALL OF A SQUARE-FRONT TRAILER, AGAINST THE FORWARD BLOCKING ASSEMBLY, OR AT THE VERY REAR OF THE LOAD. THE UNITIZING STRAPS PIECE MARKED ⑧, MUST BE INSTALLED PRIOR TO FINAL POSITIONING OF THE STACK.
6. IF THE VOID AT THE REAR OF THE LOAD BETWEEN THE PALLET UNITS AND THE REAR DOOR MEASURES 1-1/2" OR LESS REAR BLOCKING IS NOT REQUIRED. IF THE VOID AT THE REAR OF THE LOAD IS GREATER THAN 1-1/2" BUT LESS THAN 9", USE "REAR BLOCKING ASSEMBLY C" AS DETAILED ON PAGE 18. IF THE VOID AT THE REAR OF THE LOAD IS 9" OR GREATER, USE "REAR BLOCKING ASSEMBLY A" AS SHOWN.
7. IF A TRAILER WHICH IS LONGER THAN 40' IS FURNISHED FOR LOADING, OR IF THE LOAD QUANTITY IS LESS THAN SHOWN IN THE LOAD VIEW ON PAGE 4, A SPACER ASSEMBLY MAY BE REQUIRED FOR THE PURPOSE OF PROVIDING FOR PROPER WEIGHT DISTRIBUTION. SEE PIECE MARKED ② ON PAGE 6 AND SPECIAL NOTE 2 ON PAGE 7 FOR INSTALLATION GUIDANCE.
8. REFER TO PAGE 15 FOR GUIDANCE IN THE SHIPMENT OF PARTIAL PALLET UNITS.
9. LEFTOVER CONTAINERS IN AN AMOUNT NOT TO EXCEED SIX (6) MAY BE SECURED TO THE TOP OF A FULL PALLET UNIT FOR SHIPMENT. REFER TO "PROCEDURES FOR SHIPMENT OF LEFTOVER CONTAINERS" ON PAGE 14 FOR GUIDANCE.
10. TRAILERS EQUIPPED WITH ROLL-UP TYPE DOORS MAY BE USED, HOWEVER, SPECIAL REAR BLOCKING MUST BE INSTALLED. SEE THE "PROCEDURES FOR CONVENTIONAL VAN TRAILERS EQUIPPED WITH ROLL-UP TYPE DOORS" ON PAGE 20 AND 21 FOR GUIDANCE. THE NAILED-HEADER METHOD IS SHOWN ON PAGE 20 AND THE TYGARD METHOD IS SHOWN ON PAGE 21. NOTE THAT THE SPECIAL REAR BLOCKING FOR TRAILERS EQUIPPED WITH ROLL-UP TYPE DOORS MAY ALSO BE USED IN TRAILERS EQUIPPED WITH HINGED DOORS.

BILL OF MATERIAL		
LUMBER	LINEAR FEET	BOARD FEET
1" X 4"	2	1
2" X 3"	2	1
2" X 4"	147	98
2" X 6"	105	105
NAILS	NO. REQD	POUNDS
6d (2")	8	1/4
10d (3")	266	4-1/4
STEEL STRAPPING, 1-1/4" X .035" OR .031"---127' REQD---18 LBS		
SEAL FOR 1-1/4" STRAPPING---12 REQD--- 1/2 LB		

**LOAD AS SHOWN**

ITEM	QUANTITY	WEIGHT (APPROX)
PALLET UNIT	19	40,793 LBS
DUNNAGE		439 LBS
TOTAL WEIGHT		41,226 LBS (APPROX)

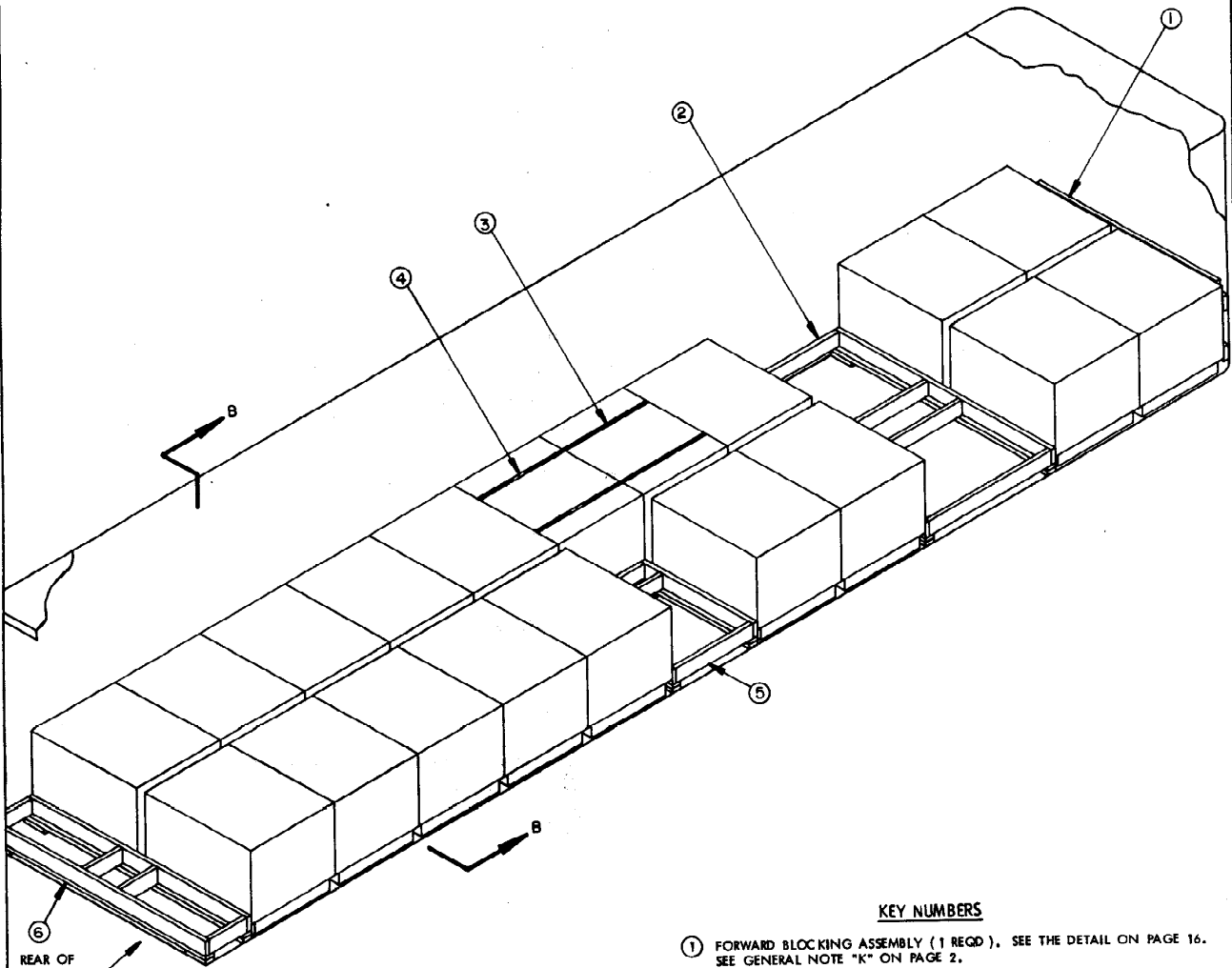

**ISOMETRIC VIEW**

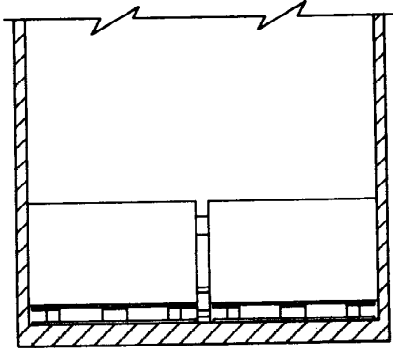

**SECTION B-B**

**KEY NUMBERS**

- ① FORWARD BLOCKING ASSEMBLY (1 REQD). SEE THE DETAIL ON PAGE 16. SEE GENERAL NOTE "K" ON PAGE 2.
- ② SPACER ASSEMBLY (1 REQD). SEE THE "SPACER ASSEMBLY B" DETAIL ON PAGE 17. SEE SPECIAL NOTE 2 ON PAGE 7.
- ③ BUNDLING STRAP, 1-1/4" X .035" OR .031" X 20'-0" LONG STEEL STRAPPING (2 REQD). INSTALL SO AS TO ENCIRCLE TWO (2) PALLET UNITS. SEE SPECIAL NOTE 3 ON PAGE 7.
- ④ SEAL FOR 1-1/4" STRAPPING (4 REQD, 2 PER STRAP). DOUBLE CRIMP EACH SEAL. SEE GENERAL NOTE "M" ON PAGE 2.
- ⑤ SPACER ASSEMBLY (1 REQD). SEE THE "SPACER ASSEMBLY A" DETAIL ON PAGE 16. SEE SPECIAL NOTE 4 ON PAGE 7.
- ⑥ REAR BLOCKING ASSEMBLY (1 REQD). SEE THE "REAR BLOCKING ASSEMBLY B" DETAIL ON PAGE 18. SEE SPECIAL NOTES 5 AND 8 ON PAGE 7.

**SPECIAL NOTES:**

1. A 19-UNIT LOAD IS SHOWN IN A 40'-0" LONG BY 8'-2" WIDE (INSIDE DIMENSION) CONVENTIONAL VAN TYPE TRAILER. TRAILERS OF OTHER DIMENSIONS CAN BE USED.
2. SPACER ASSEMBLY "B" SHOWN AS PIECE MARKED ② IN THE LOAD ON PAGE 6 IS USED FOR THE PURPOSE OF PROVIDING FOR PROPER WEIGHT DISTRIBUTION, AND IS SHOWN AS TYPICAL ONLY. IF THE TRAILER TO BE LOADED IS LONGER THAN 40' THE LOCATION OF THE ASSEMBLY, AND/OR THE STRUT LENGTHS, MAY BE DIFFERENT FROM WHAT IS SHOWN. IF A SHORTER TRAILER IS USED FOR THE DEPICTED LOAD, THIS ASSEMBLY MAY NOT BE REQUIRED. NOTE THAT A SPACER ASSEMBLY MUST NOT BE POSITIONED ADJACENT TO THE FORWARD BLOCKING ASSEMBLY, PIECE MARKED ①.
3. A PALLET UNIT THAT DOES NOT HAVE A PALLET UNIT DIRECTLY OPPOSITE MUST BE SECURED BY INSTALLING BUNDLING STRAPS, SHOWN AS PIECE MARKED ③ IN THE LOAD ON PAGE 6, AROUND THAT PALLET UNIT AND THE PALLET UNIT IMMEDIATELY ADJACENT.
4. THE SPACER ASSEMBLY SHOWN AS PIECE MARKED ⑤ IN THE LOAD VIEW IS ONLY SHOWN TO DEPICT A TYPICAL INSTALLATION. IF A PALLET UNIT IS LOADED IN PLACE OF THE SPACER ASSEMBLY, BUNDLING STRAPS, SHOWN AS PIECE MARKED ③, WILL NOT BE REQUIRED. NOTE THAT A SPACER ASSEMBLY MUST BE POSITIONED WHERE THERE WILL BE A PALLET UNIT AT EACH END. A SPACER ASSEMBLY MUST NOT BE POSITIONED ADJACENT TO THE FORWARD BLOCKING ASSEMBLY, PIECE MARKED ①.
5. IF THE SPACE AT THE REAR OF THE LOAD BETWEEN THE PALLET UNITS AND THE REAR DOOR IS GREATER THAN 1-1/2" BUT LESS THAN 9", USE REAR BLOCKING ASSEMBLY "C" AS DETAILED ON PAGE 18. IF THE VOID AT THE REAR OF THE LOAD IS 9" OR GREATER, USE THE REAR BLOCKING ASSEMBLY "B" AS SHOWN. IF THE VOID AT THE REAR OF THE LOAD MEASURES 1-1/2" OR LESS REAR BLOCKING IS NOT REQUIRED.
6. REFER TO PAGE 15 FOR GUIDANCE IN THE SHIPMENT OF PARTIAL PALLET UNITS.
7. LEFTOVER CONTAINERS IN AN AMOUNT NOT TO EXCEED SIX (6) MAY BE SECURED TO THE TOP OF A FULL PALLET UNIT FOR SHIPMENT. REFER TO THE "PROCEDURES FOR SHIPMENT OF LEFTOVER CONTAINERS" ON PAGE 14 FOR GUIDANCE.
8. TRAILERS EQUIPPED WITH ROLL-UP TYPE DOORS MAY BE USED; HOWEVER, SPECIAL REAR BLOCKING MUST BE INSTALLED. SEE THE "PROCEDURES FOR CONVENTIONAL VAN TRAILERS EQUIPPED WITH ROLL-UP TYPE DOORS" ON PAGES 20 AND 21 FOR GUIDANCE. THE NAILED HEADER METHOD IS SHOWN ON PAGE 20 AND THE TYGARD METHOD IS SHOWN ON PAGE 21. NOTE THAT THE SPECIAL REAR BLOCKING FOR TRAILERS EQUIPPED WITH ROLL-UP TYPE DOORS MAY ALSO BE USED IN TRAILERS EQUIPPED WITH HINGED DOORS.

BILL OF MATERIAL		
LUMBER	LINEAR FEET	BOARD FEET
2" X 3"	3	2
2" X 4"	62	42
2" X 6"	107	107
NAILS	NO. REQD	POUNDS
10d (3")	180	3
STEEL STRAPPING, 1-1/4" X .035" OR .031"---40' REQD		6 LBS
SEAL FOR 1-1/4" STRAPPING		4 REQD NIL

**LOAD AS SHOWN**

ITEM	QUANTITY	WEIGHT (APPROX)
PALLET UNIT	19	40,793 LBS
DUNNAGE		307 LBS
TOTAL WEIGHT		41,100 LBS (APPROX)

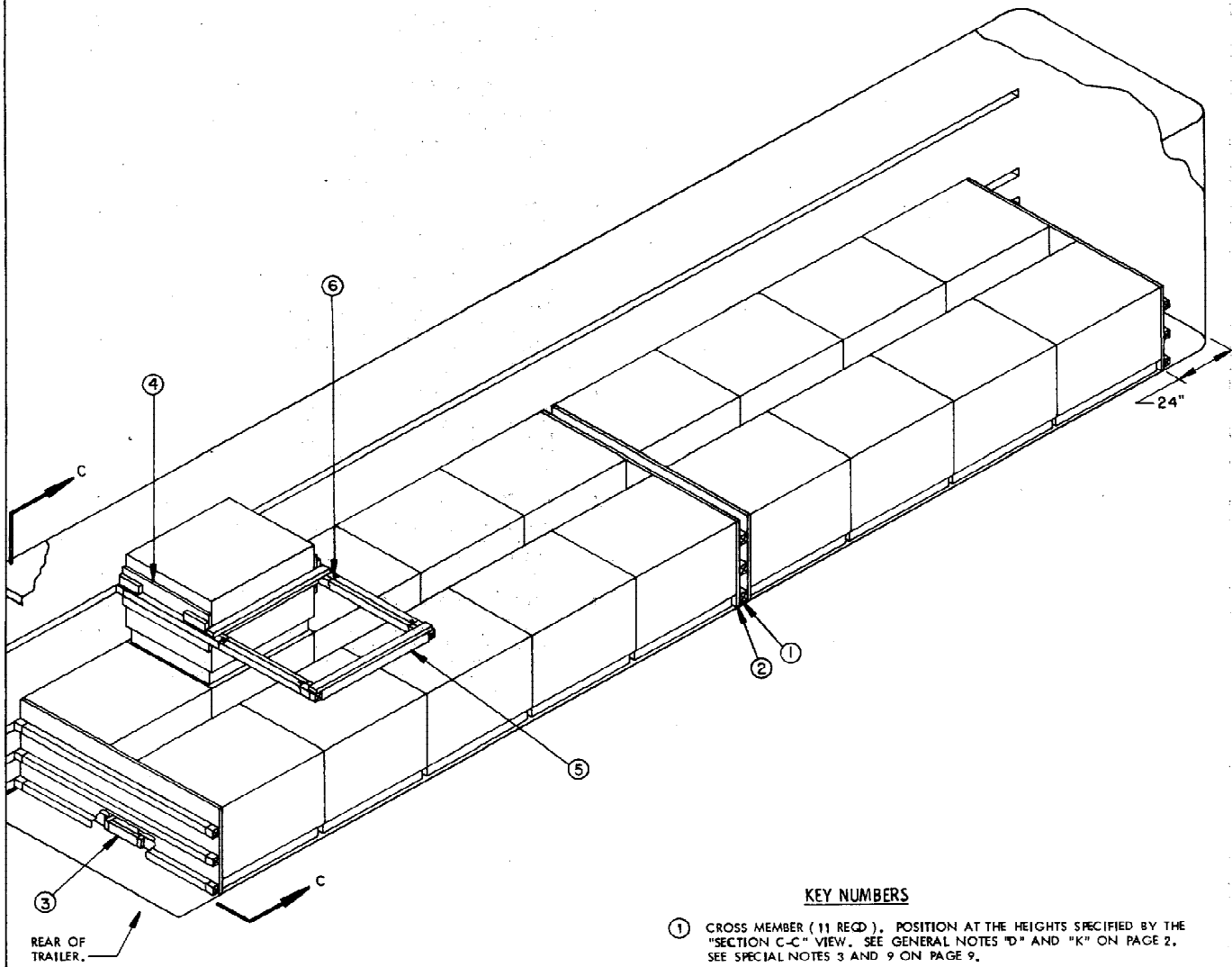

ISOMETRIC VIEW

THESE DIMENSIONED HEIGHTS SPECIFY THE DISTANCE THE TOP SURFACE OF A CROSS MEMBER IS TO BE ABOVE THE TRAILER FLOOR. EXCEPT FOR THE BOTTOM CROSS MEMBER, PLUS OR MINUS 2" IS PERMITTED.

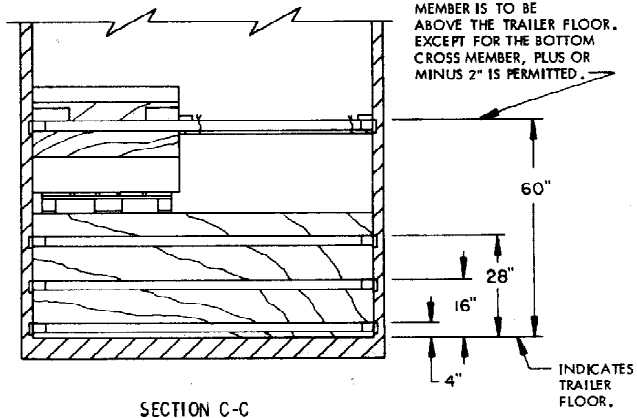

SECTION C-C

KEY NUMBERS

- ① CROSS MEMBER (11 REQD). POSITION AT THE HEIGHTS SPECIFIED BY THE "SECTION C-C" VIEW. SEE GENERAL NOTES "D" AND "K" ON PAGE 2. SEE SPECIAL NOTES 3 AND 9 ON PAGE 9.
- ② LOAD BEARING GATE (4 REQD). SEE THE "LOAD BEARING GATE A" DETAIL ON PAGE 19. SEE SPECIAL NOTE 2 ON PAGE 9.
- ③ ANTI-SWAY BRACE (9 REQD). POSITION ON THE FLOOR BETWEEN LATERALLY ADJACENT PALLET UNITS. SEE THE "ANTI-SWAY BRACE A" DETAIL ON PAGE 16. SEE GENERAL NOTES "O" AND "P" ON PAGE 2, AND SPECIAL NOTE 4 ON PAGE 9.
- ④ LOAD BEARING GATE FOR 1 PALLET WIDE (2 REQD). SEE THE "LOAD BEARING GATE B" DETAIL ON PAGE 19.
- ⑤ SPACER ASSEMBLY (1 REQD). SEE THE "SPACER ASSEMBLY C" DETAIL ON PAGE 17.
- ⑥ TIE WIRE, NO. 14 GAGE WIRE 24" LONG (4 REQD). SECURE TO THE SPACER ASSEMBLY WITH A PARTIALLY DRIVEN 10d NAIL BENT OVER THE WIRE, OR WITH A STRAP STAPLE.



SPECIAL NOTES:

1. A 19-UNIT LOAD IS SHOWN IN A 40'-0" LONG BY 7'-6" (INSIDE DIMENSION) VAN TRAILER EQUIPPED WITH MECHANICAL BRACING DEVICES. TRAILERS OF OTHER DIMENSIONS CAN BE USED.
2. IF PLYWOOD IS NOT AVAILABLE FOR THE CONSTRUCTION OF LOAD BEARING GATES, OR IF DESIRED, PIECES MARKED ② AND ④ MAY BE CONSTRUCTED FROM 1" AND/OR 2" LUMBER. SEE THE ALTERNATIVE LOAD BEARING GATE "A" AND "B" DETAILS ON PAGE 19.
3. IF THE CROSS MEMBERS, SHOWN AS PIECE MARKED ① IN THE LOAD VIEW CONTACT THE DUNNAGE ASSEMBLIES OF A UNIT BY AT LEAST ONE-HALF THE SURFACE OF THE HEIGHT OF THE CROSS MEMBERS, LOAD BEARING GATES, PIECES MARKED ② AND ④ WILL NOT BE REQUIRED. NOTE THAT A 1" X 5" BY TRAILER WIDTH MINUS 1" (ACTUAL SIZE) FILL PIECE, MUST BE POSITIONED ON EDGE BETWEEN THE PALLET AND THE CROSS MEMBER LOCATED AT THE 4" HEIGHT TO PROVIDE A BEARING SURFACE FOR PIECE MARKED ①. ALSO, THE LENGTH OF PIECES MARKED ③ WHICH ARE ADJACENT TO A CROSS MEMBER, WILL BE 3/4" SHORTER.
4. ANTI-SWAY BRACE, SHOWN AS PIECE MARKED ⑤ IN THE LOAD ON PAGE 8 IS TO BE POSITIONED BETWEEN ALL Laterally ADJACENT PALLET UNITS. IF SPACE PERMITS, ANTI-SWAY BRACE "B" MAY BE USED IN LIEU OF ANTI-SWAY BRACE "A".
5. A SPACER ASSEMBLY "C", PIECE MARKED ⑥, IS ONLY REQUIRED WHEN A PALLET UNIT DOES NOT HAVE A PALLET UNIT DIRECTLY OPPOSITE IN THE SECOND LAYER. IF THE LOAD IS EITHER INCREASED OR DECREASED BY ONE PALLET UNIT THE SPACER ASSEMBLY WILL BE OMITTED.
6. REFER TO PAGE 15 FOR GUIDANCE IN THE SHIPMENT OF PARTIAL PALLET UNITS.
7. LEFTOVER CONTAINERS IN AN AMOUNT NOT TO EXCEED SIX (6) MAY BE SECURED TO THE TOP OF A FULL PALLET UNIT FOR SHIPMENT. REFER TO THE "PROCEDURES FOR SHIPMENT OF LEFTOVER CONTAINERS" ON PAGE 14 FOR GUIDANCE.
8. FOR SHIPMENT OF LESS THAN FULL LOADS, REFER TO THE APPLICABLE GUIDANCE ON PAGE 13.
9. IF THE TRAILER BEING LOADED IS EQUIPPED ONLY WITH SHORT WALL MEMBERS AT THE REAR FOR ATTACHMENT OF THE CROSS MEMBERS, THE CROSS MEMBERS AND LOAD BEARING GATE, PIECES MARKED ① AND ② LOCATED AT THE FRONT OF THE TRAILER WILL BE OMITTED. UNLESS THE TRAILER HAS A SQUARE FRONT, FORWARD BLOCKING WILL BE REQUIRED.

**BILL OF MATERIAL**

LUMBER	LINEAR FEET	BOARD FEET
2" X 4"	138	92
NAILS	NO. REQD	POUNDS
6d (2")	12	1/4
10d (3")	164	2-1/2
PLYWOOD, 1/2"-----	93 SQ FT REQD-----	128 LBS
WIRE, NO. 14 GAGE-----	8' REQD-----	NIL
CROSS MEMBER-----		11 REQD

LOAD AS SHOWN

<u>ITEM</u>	<u>QUANTITY</u>	<u>WEIGHT (APPROX)</u>
PALLET UNIT-----	19-----	40,793 LBS
DUNNAGE-----		315 LBS
TOTAL WEIGHT-----		41,108 LBS (APPROX)

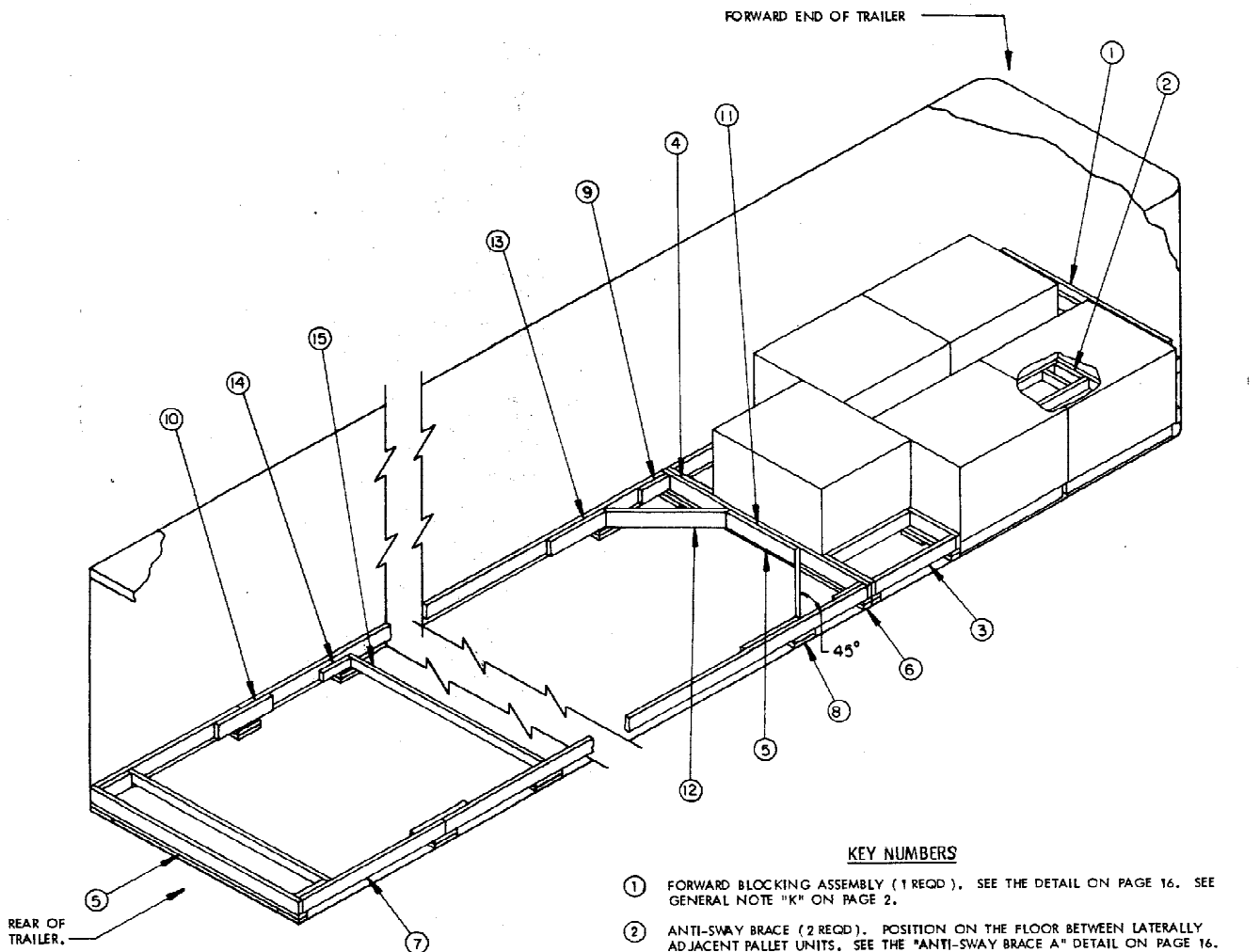

ISOMETRIC VIEW

(KEY NUMBERS CONTINUED)

- ⑬ BACK-UP CLEAT, 2" X 6" X 24" (2 REQD). NAIL TO A SIDE STRUT, PIECE MARKED ⑦, W/8-10d NAILS.
- ⑭ STRUT BRACE RETAINING CLEAT, 2" X 4" X 12" (AS REQD). NAIL TO A SIDE STRUT, PIECE MARKED ⑦, W/3-10d NAILS. SEE SPECIAL NOTE 4 ON PAGE 11.
- ⑮ STRUT BRACE, 2" X 4" BY TRAILER WIDTH MINUS 3" IN LENGTH (MINIMUM OF ONE REQUIRED). NAIL TO THE POCKET CLEATS, PIECES MARKED ⑨ AND/OR TO THE STRUT BRACE RETAINING CLEATS, PIECES MARKED ⑭, W/2-12d NAILS AT EACH END. SEE SPECIAL NOTE 4 ON PAGE 11.

KEY NUMBERS

- ① FORWARD BLOCKING ASSEMBLY (1 REQD). SEE THE DETAIL ON PAGE 16. SEE GENERAL NOTE "K" ON PAGE 2.
- ② ANTI-SWAY BRACE (2 REQD). POSITION ON THE FLOOR BETWEEN LATERALLY ADJACENT PALLET UNITS. SEE THE "ANTI-SWAY BRACE A" DETAIL ON PAGE 16.
- ③ SPACER ASSEMBLY (2 REQD). SEE THE "SPACER ASSEMBLY D" DETAIL ON PAGE 17. NAIL TO A HEADER, PIECE MARKED ④, W/2-10d NAILS. SEE SPECIAL NOTE 2 ON PAGE 11.
- ④ HEADER, 2" X 6" BY TRAILER WIDTH MINUS 1/2" IN LENGTH (2 REQD). SEE SPECIAL NOTES 6 THRU 8 ON PAGE 11.
- ⑤ HEADER AND SIDE STRUT SUPPORT, 2" X 4" BY TRAILER WIDTH MINUS 1/2" IN LENGTH (2 REQD). NAIL TO THE BOTTOM EDGE OF A HEADER, PIECE MARKED ④ W/1-10d NAIL EVERY 8".
- ⑥ RISER PIECE, 2" X 4" X 9" (4 REQD). POSITION UNDER EACH END OF HEADER AND SIDE STRUT SUPPORT PIECES MARKED ⑤. NAIL TO PIECE MARKED ⑤ W/2-10d NAIL NAILS.
- ⑦ SIDE STRUT, 2" X 6" BY CUT-TO-FIT BETWEEN THE FORWARD AND REAR HEADERS, PIECES MARKED ④ (2 REQD). SEE SPECIAL NOTE 3 ON PAGE 11.
- ⑧ RISER PIECE, 2" X 4" X 9" (DOUBLED) (AS REQD). LAMINATE W/2-10d NAILS. CENTER UNDER THE JOINTS OF PIECES MARKED ⑬ AND ⑭, ⑮ AND ⑯ AND UNDER THE SPLICE OF PIECES MARKED ⑩ IF APPLICABLE. NAIL TO SIDE STRUT MARKED ⑦ W/2-10d NAILS.
- ⑨ POCKET CLEAT, 2" X 6" X 12" (4 REQD). NAIL TO A SIDE STRUT, PIECE MARKED ⑦, W/3-10d NAILS. TOENAIL TO THE ADJACENT HEADER, PIECE MARKED ④, W/3-12d NAILS.
- ⑩ SPLICE PIECE, 2" X 6" X 24" (AS REQD). CENTER ON JOINT OF PIECES MARKED ⑦ AND NAIL TO SIDE STRUT MARKED ⑦ W/4-10d NAILS AT EACH END. SEE SPECIAL NOTE 3 ON PAGE 11.
- ⑪ CENTER CLEAT, 2" X 6" X 30" (1 REQD). NAIL TO A HEADER, PIECE MARKED ④, W/6-10d NAILS.
- ⑫ DIAGONAL BRACE, 2" X 6" BY CUT-TO-FIT (2 REQD). DOUBLE BEVEL EACH END WITH 45° CUTS. INSTALL AT A 45° ANGLE AS SHOWN AND TOENAIL TO THE ADJACENT HEADER AND SIDE STRUT, PIECES MARKED ④ AND ⑦, W/2-16d NAILS AT EACH END.

(CONTINUED AT LEFT)

SPECIAL NOTES:

1. A 7'-6" WIDE (INSIDE DIMENSION) CONVENTIONAL VAN TRAILER IS SHOWN. TRAILERS OF OTHER WIDTHS CAN BE USED.
2. THE SPACER ASSEMBLIES, PIECE MARKED ③, ARE SHOWN ONLY TO DEPICT A TYPICAL INSTALLATION. SPACER ASSEMBLIES WILL BE USED WHEN A PALLET UNIT IS OMITTED. THEY MAY OR MAY NOT BE REQUIRED, DEPENDING ON THE QUANTITY OF PALLET UNITS TO BE SHIPPED.
3. DEPENDING ON THE NUMBER OF UNITS BEING LOADED, EACH OF THE SIDE STRUTS, PIECES MARKED ⑦, MAY NEED TO BE FORMED FROM MORE THAN ONE PIECE OF MATERIAL. IF SUCH IS THE CASE, THE SIDE STRUTS MUST BE SPLICED. SPLICING CAN BE ACCOMPLISHED BY CENTERING A 2" X 6" X 24" PIECE ON THE JOINT OF THE SIDE STRUTS AND NAILING IT TO THE SIDE STRUTS W/4-10# NAILS AT EACH END. CAUTION: A RISER PIECE, PIECE MARKED ⑧, MUST BE POSITIONED UNDER EACH SPLICE JOINT. NOTE: IF DESIRED, THE STRUT BRACING PIECE (S), PIECE MARKED ⑬, MAY BE NAILED TO THE SPLICE PIECES IN LIEU OF USING ADDITIONAL STRUT BRACE RETAINING CLEATS, PIECES MARKED ⑭.
4. ALL LTL LOADS, REGARDLESS OF THEIR SIZE, REQUIRE ONE STRUT BRACE POSITIONED AT THE REAR OF THE TRAILER AND NAILED TO PIECE MARKED ⑨ IF THE SIDE STRUTS, PIECES MARKED ⑦, ARE LONGER THAN 7'-0". AN ADDITIONAL STRUT BRACE, PIECE MARKED ⑮, AND TWO (2) STRUT BRACE RETAINING CLEATS, PIECES MARKED ⑭, AND TWO (2) RISER PIECES MARKED ⑧, MUST BE APPLIED FOR EVERY 7'-0" OF SIDE STRUT LENGTH.
5. THE "K-BRACE" BLOCKING, SHOWN AS PIECES MARKED ④ THRU ⑮, IS ADEQUATE FOR RETAINING A MAXIMUM LTL LOAD OF 20,000 POUNDS.
6. TRAILERS EQUIPPED WITH ROLL-UP TYPE DOORS MAY BE USED, HOWEVER, SPECIAL REAR BLOCKING MUST BE INSTALLED IN LIEU OF THE "K-BRACE TYPE BLOCKING". SEE THE "PROCEDURES FOR CONVENTIONAL VAN TRAILERS EQUIPPED WITH ROLL-UP TYPE DOORS" ON PAGES 20 AND 21 FOR GUIDANCE. A NAILED-HEADER METHOD AND A TYGARD METHOD ARE SHOWN. NOTE THAT THE SPECIAL REAR BLOCKING FOR TRAILERS EQUIPPED WITH ROLL-UP TYPE DOORS MAY ALSO BE USED IN TRAILERS EQUIPPED WITH HINGED DOORS, AND MAY BE USED IN LIEU OF PIECES MARKED ④ THRU ⑮ WHICH APPLY TO TRAILERS HAVING NON-NAILABLE FLOORS.
7. WHEN THE NAILED-HEADER METHOD OF BRACING SHOWN ON PAGE 20 IS APPLIED FOR THE BRACING OF THE DEPICTED 5-UNIT LOAD OR ANY ODD NUMBERED QUANTITY, OMIT THE REAR BLOCKING ASSEMBLY AND SUBSTITUTE 2" X 6" MATERIAL FOR THE 2" X 4" HEADER MATERIAL TO FACILITATE NAILING; NOTE THAT THE LENGTH OF THE SPACER ASSEMBLY, PIECE MARKED ③, WILL HAVE TO BE ADJUSTED TO ACCOMMODATE THE HEADER. WHEN SHIPPING AN EVEN NUMBERED QUANTITY, THE NAILED-HEADER METHOD WILL APPLY AS SHOWN.
8. IF DESIRED, IN TRAILERS EQUIPPED WITH NAILABLE FLOORS, THE NAILED-HEADER METHOD OF REAR BLOCKING MAY BE USED IN LIEU OF THE K-BRACE BLOCKING SHOWN AS PIECES MARKED ④ THRU ⑮. REFER TO PAGE 20 FOR GUIDANCE. AS AN ALTERNATIVE IN NAILABLE FLOOR TRAILERS, OR IN TRAILERS HAVING NON-NAILABLE FLOORS, THE TYGARD METHOD DEPICTED ON PAGE 21 MAY BE USED.
9. REFER TO PAGE 15 FOR GUIDANCE IN THE SHIPMENT OF PARTIAL PALLET UNITS.
10. LEFTOVER CONTAINERS, IN AN AMOUNT NOT TO EXCEED SIX (6), MAY BE SECURED TO THE TOP OF A FULL PALLET UNIT FOR SHIPMENT. REFER TO THE "PROCEDURES FOR SHIPMENT OF LEFTOVER CONTAINERS" ON PAGE 14 FOR GUIDANCE.

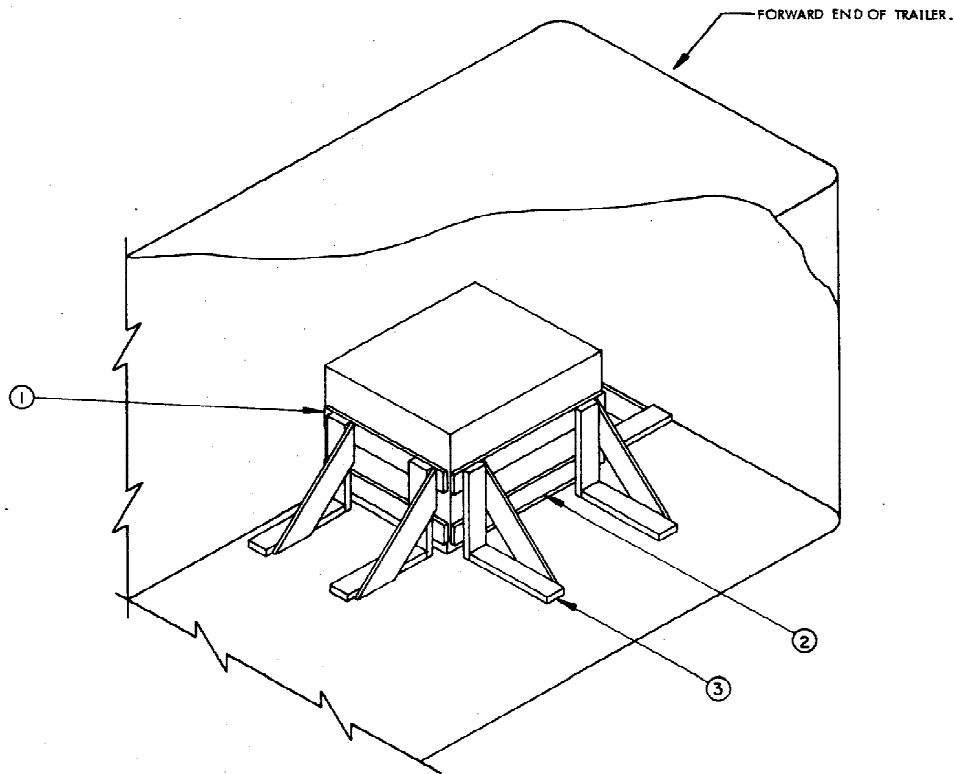

ISOMETRIC VIEW

KEY NUMBERS

SPECIAL NOTES:

1. A 7'-6" WIDE (INSIDE DIMENSION) TRAILER WHICH HAS A NAILABLE FLOOR IS SHOWN. TRAILERS OF OTHER WIDTHS CAN BE USED.
2. THE POSITIONING OF A SINGLE PALLET UNIT IS OPTIONAL. IF THE TRAILER HAS A SQUARE FRONT, THE TWO (2) FORWARD LTL BRACES MAY BE OMITTED AND THE UNIT POSITIONED AGAINST THE END WALL.
3. MORE THAN ONE PALLET UNIT CAN BE SHIPPED PROVIDING THE CAPACITY OF THE LTL BRACES IS NOT EXCEEDED, THE LOAD SHOULD BE FORMED IN ROWS, WITH THE UNITS POSITIONED AGAINST OPPOSITE SIDEWALLS. THE ANTI-SWAY BRACE "A" OR "B", DETAILED ON PAGE 16, MUST BE INSTALLED BETWEEN LATERALLY ADJACENT UNITS, HOWEVER, A DOUBLED 2" X 4" X 12" STOP PIECE MUST BE NAILED TO THE FLOOR AT EACH END OF "ANTI-SWAY BRACE A".
4. EACH LTL BRACE AS APPLIED FOR LONGITUDINAL BRACING WILL SUPPORT 2,000 POUNDS OF LADING, HOWEVER, NOT LESS THAN TWO (2) BRACES WILL BE USED AGAINST EACH PALLET UNIT ACROSS THE WIDTH OF THE TRAILER. ADDITIONAL BRACES MAY BE INSTALLED FOR THE RETENTION OF A HEAVIER LOAD.

- ① LOAD BEARING PIECE, 1" X 6" X 98" (4 REQD). LOCATE AT THE HEIGHTS AS SPECIFIED IN THE "LTL BRACE" DETAIL BELOW. NAIL TO THE LTL BRACES W/4-6d NAILS AT EACH JOINT. SEE GENERAL NOTE "O" ON PAGE 2.
- ② LOAD BEARING PIECE, 1" X 6" X 47" (2 REQD). LOCATE AT THE HEIGHTS AS SPECIFIED IN THE "LTL BRACE" DETAIL BELOW. NAIL TO THE LTL BRACES W/4-6d NAILS AT EACH JOINT.
- ③ LTL BRACE (6 REQD). SEE THE "LTL BRACE" DETAIL BELOW. NAIL TO THE TRAILER FLOOR W/10-10d NAILS.

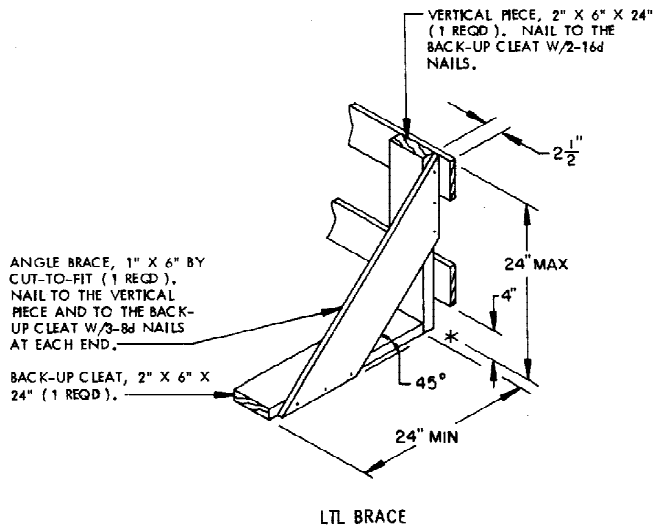

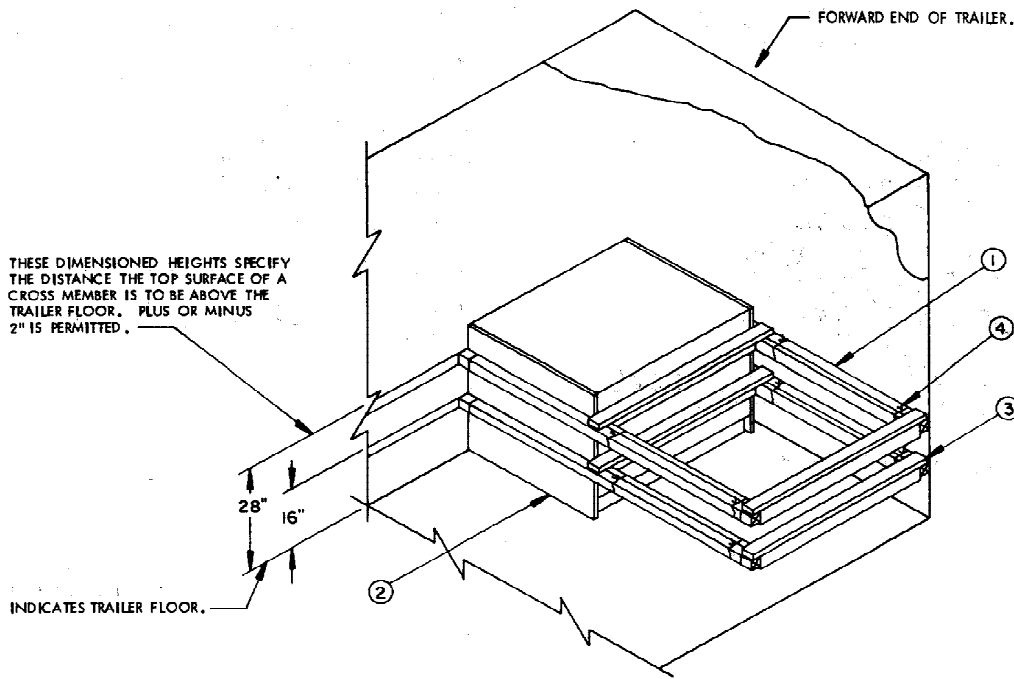

ISOMETRIC VIEW

**SPECIAL NOTES:**

1. A 7'-6" WIDE (INSIDE DIMENSION) VAN TRAILER EQUIPPED WITH MECHANICAL BRACING DEVICES IS SHOWN. TRAILERS OF OTHER WIDTHS MAY BE USED.
2. A TYPICAL LTL LOAD OF ONE (1) PALLETIZED UNIT IS SHOWN. IF TWO (2) PALLETIZED UNITS ARE TO BE TRANSPORTED, POSITION THE UNITS TWO ACROSS THE WIDTH OF THE TRAILER. OMIT THE SPACER ASSEMBLIES AND THE TIE WIRES SHOWN AS PIECES MARKED ③ AND ④. NOTE: WHEN LOADING TWO (2) PALLETIZED UNITS ACROSS THE WIDTH OF THE TRAILER, POSITION THE UNITS AGAINST THE FORWARD END WALL (UNLESS THE TRAILER HAS ROUNDED CORNERS) AND OMIT THE TWO CROSS MEMBERS AT THE FORWARD END. POSITION ONE ANTI-SWAY BRACE, SHOWN AS PIECE MARKED ⑤ ON PAGE 8, BETWEEN THE UNITS.

**KEY NUMBERS**

- ① CROSS MEMBER (4 REQD). POSITION AT THE HEIGHTS AS SPECIFIED BY THE ISOMETRIC VIEW ABOVE. SEE GENERAL NOTES "D" AND "K" ON PAGE 2.
- ② PLYWOOD, 1/2" X 38" X 34" (2 REQD). POSITION BETWEEN THE PALLET UNIT AND THE CROSS MEMBERS.
- ③ SPACER ASSEMBLY (2 REQD). SEE THE SPACER ASSEMBLY "C" DETAIL ON PAGE 17.
- ④ TIE WIRE, NO. 14 GAGE WIRE 30" LONG (8 REQD). INSTALL TO FORM A COMPLETE LOOP AROUND THE CROSS MEMBER AND THE SPACER ASSEMBLY. BRING ENDS TOGETHER AND TWIST TAUT. SECURE TO THE SPACER ASSEMBLY WITH A PARTIALLY DRIVEN 10d NAIL BENT OVER THE WIRE, OR WITH A STRAP STAPLE.

**SPECIAL NOTES:**

1. SHIPMENTS OF COMPLETE ROUNDS SHOULD CONSIST OF FULL-HEIGHT AND FULL-LAYER UNITS TO THE MAXIMUM EXTENT POSSIBLE, HOWEVER, THE END OF A LOT, OR THE QUANTITY OF ITEMS NEEDED TO FILL A REQUISITION, MAY NECESSITATE THE SHIPMENT OF ONE OR MORE LEFTOVER CONTAINERS. LEFTOVER CONTAINERS ARE DESCRIBED AS A QUANTITY OF CONTAINERS WHICH IS INSUFFICIENT TO FORM A FULL-LAYERED PARTIAL UNIT FOR SECUREMENT ON TOP OF A FULL PALLET UNIT AS SHOWN ON PAGE 15.
2. SHIPMENT OF LEFTOVER CONTAINERS IS APPLICABLE FOR CONUS AND OCONUS MOTOR CARRIER SHIPMENTS FROM DEPOT TO DEPOT OR FROM DEPOT TO POSTS, CAMPS, AND STATIONS, OR UPON APPROVAL FROM HIGHER HEADQUARTERS, FOR SHIPMENTS FROM LOAD, ASSEMBLY, AND PACK PLANTS TO DEPOTS. **CAUTION:** A LOAD CONTAINING LEFTOVER CONTAINERS IN AN AMOUNT WHICH IS LESS THAN A FULL LAYER, AND SECURED TO THE TOP OF A FULL OR PARTIAL UNIT, MUST NOT BE DESTINED FOR SHIPMENT OVERSEAS BY WATER CARRIER.
3. THE PROCEDURES ON THIS PAGE ARE APPLICABLE FOR THE SHIPMENT OF LEFTOVER CONTAINERS IN ANY OF THE LOADS DEPICTED HEREIN.
4. NOTE THAT THE UNITIZING STRAP MAY BE THREADED UNDERNEATH THE PALLET BOARDS AS AN ALTERNATIVE TO GOING BETWEEN THE LAYERS OF CONTAINERS.

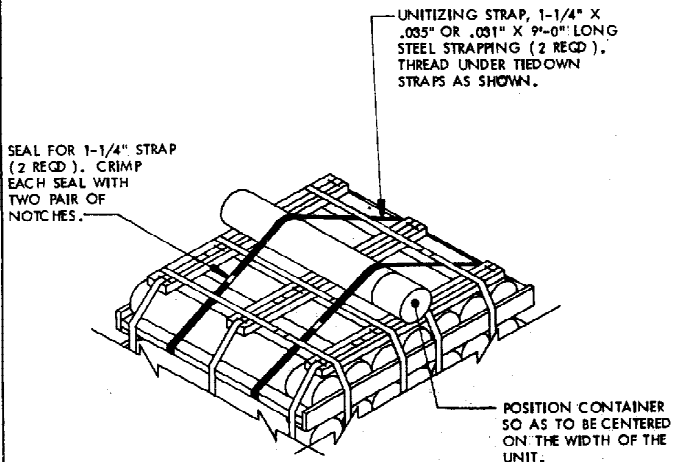

**SECUREMENT OF ONE CONTAINER**

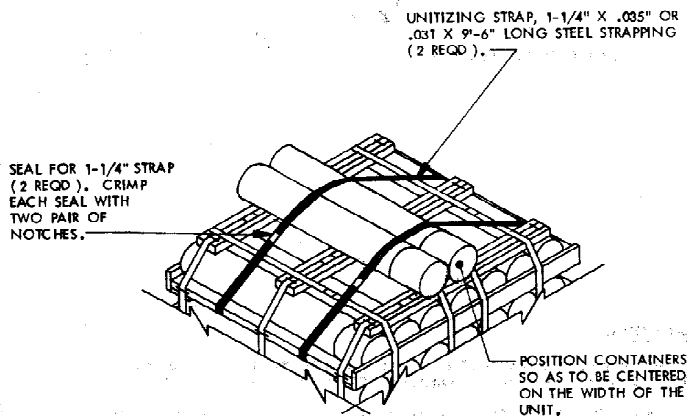

**SECUREMENT OF TWO CONTAINERS**

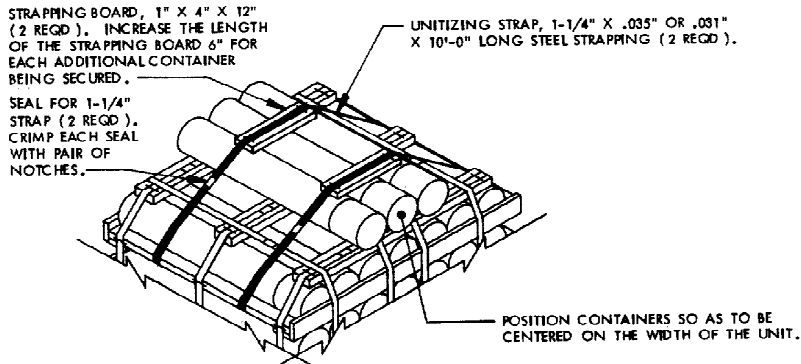

**SECUREMENT OF THREE CONTAINERS**

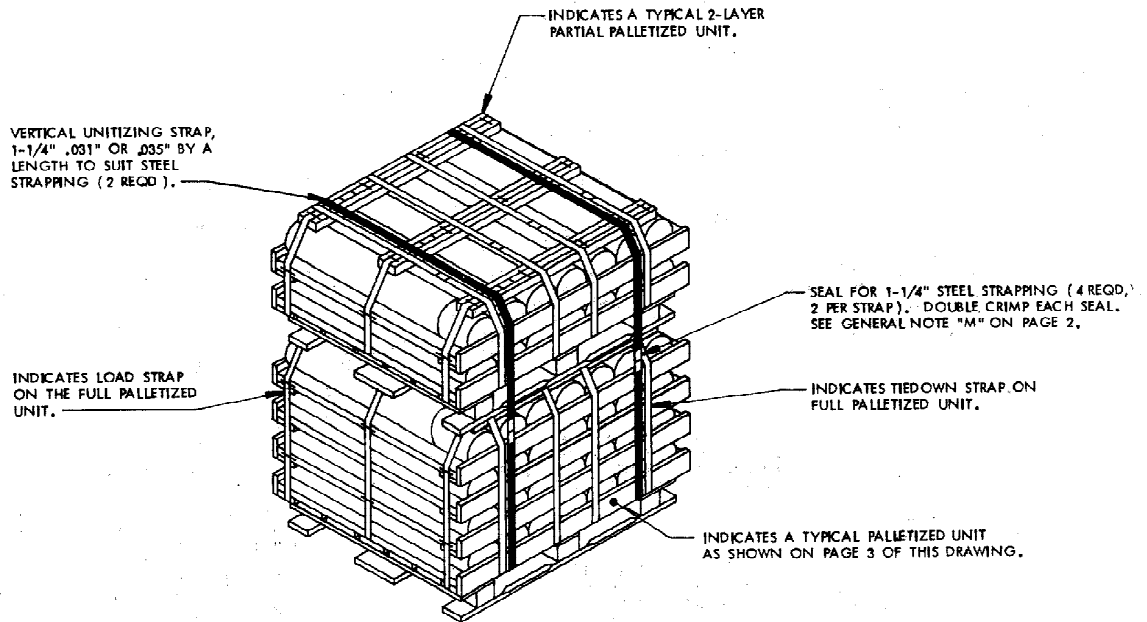

SECUREMENT OF A PARTIAL PALLET UNIT  
ON TOP OF A FULL PALLET UNIT

**SPECIAL NOTES:**

1. THE VIEW SHOWN ABOVE DEPICTS A PARTIAL 2-LAYER PALLET UNIT POSITIONED ON TOP OF A FULL-HEIGHT PALLET UNIT AND UNITIZED WITH TWO VERTICAL UNITIZING STRAPS. PLACEMENT WITHIN THE LOAD IS OPTIONAL, EXCEPT THAT IT WILL NOT BE POSITIONED ADJACENT TO SPACER ASSEMBLY MARKED ⑥ IN THE LOAD ON PAGE 4, AND MARKED ② AND ③ IN THE LOAD ON PAGE 6; IN THE REAR LOAD UNIT OR WITHIN A GROUP WHICH IS BUNDLED TOGETHER.
2. SHIPMENTS OF PALLET UNITS SHOULD CONSIST OF FULL-HEIGHT AND FULL-LAYER UNITS TO THE MAXIMUM EXTENT POSSIBLE, HOWEVER, THE END OF A LOT, OR THE QUANTITY OF ITEMS NEEDED TO FILL A REQUISITION MAY NECESSITATE THE SHIPMENT OF ONE OR MORE LESS-THAN-FULL PALLET UNITS WITHIN A LOAD. THE PROCEDURES ON THIS PAGE AND ON PAGE 14 ARE PRESENTED AS GUIDANCE IN THE SHIPMENT OF THESE PARTIAL UNITS.
3. THE "SHIPMENTS OF A PARTIAL PALLET UNIT" PROCEDURES ON THIS PAGE ARE APPLICABLE FOR LOADS IN CONVENTIONAL TYPE VAN TRAILERS AND IN TRAILERS EQUIPPED WITH MECHANICAL BRACING DEVICES.
4. FOR SHIPMENTS OF ONE THRU SIX "LEFTOVER" CONTAINERS, SEE THE PROCEDURES ON PAGE 14 OF THIS DRAWING.

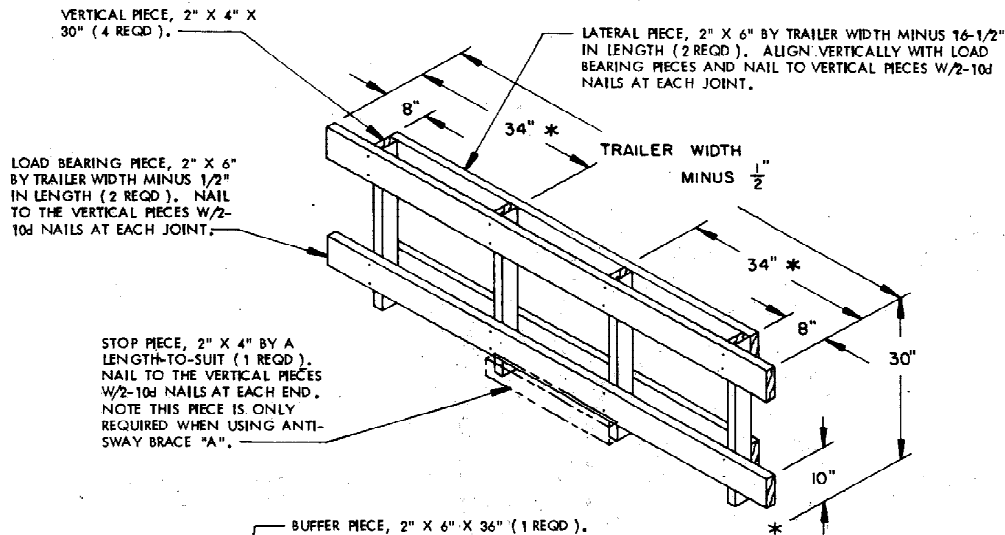

### FORWARD BLOCKING ASSEMBLY

THIS ASSEMBLY IS DESIGNED FOR USE AT THE FRONT END OF A TRAILER HAVING ROUNDED CORNERS, AND IS APPLICABLE FOR A CORNER RADIUS OF NOT MORE THAN 6-1/2". IF THE RADIUS IS FROM 6-1/2" TO 8", 2" X 6" VERTICAL PIECES WILL BE USED IN LIEU OF THE 2" X 4" PIECES. IF THE TRAILER TO BE LOADED HAS LARGE-ANGLED CORNERS AT THE FORWARD END, REFER TO PAGE 22 FOR GUIDANCE.

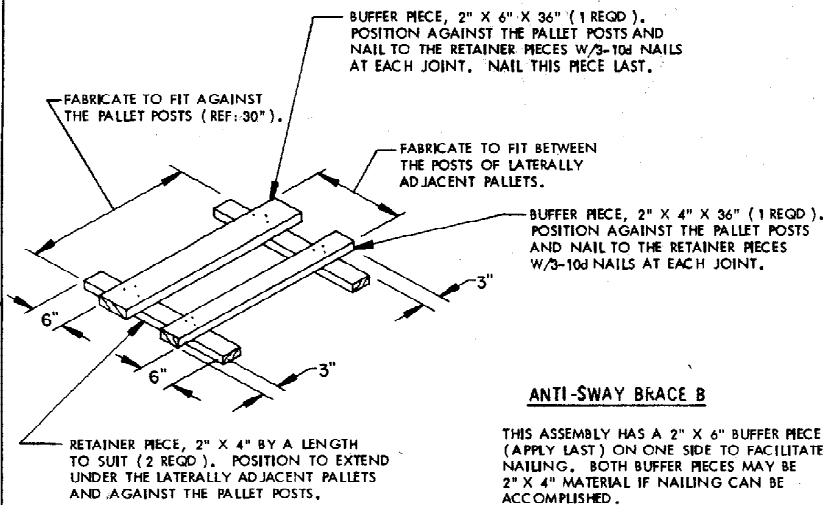

\* THIS DIMENSION WILL BE 42" IF THE CONTAINERS ARE POSITIONED LENGTHWISE.

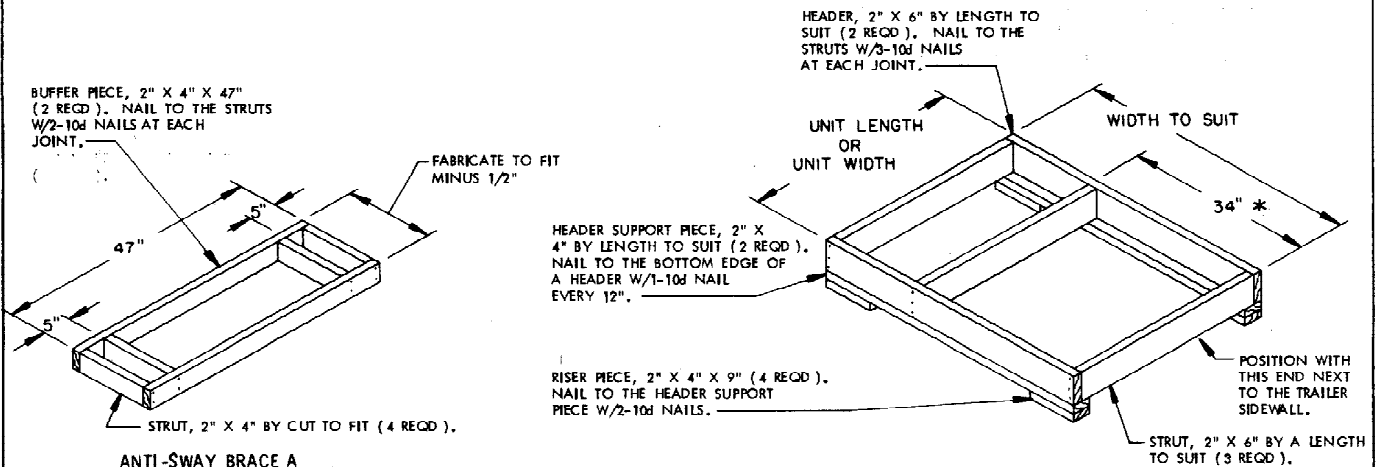



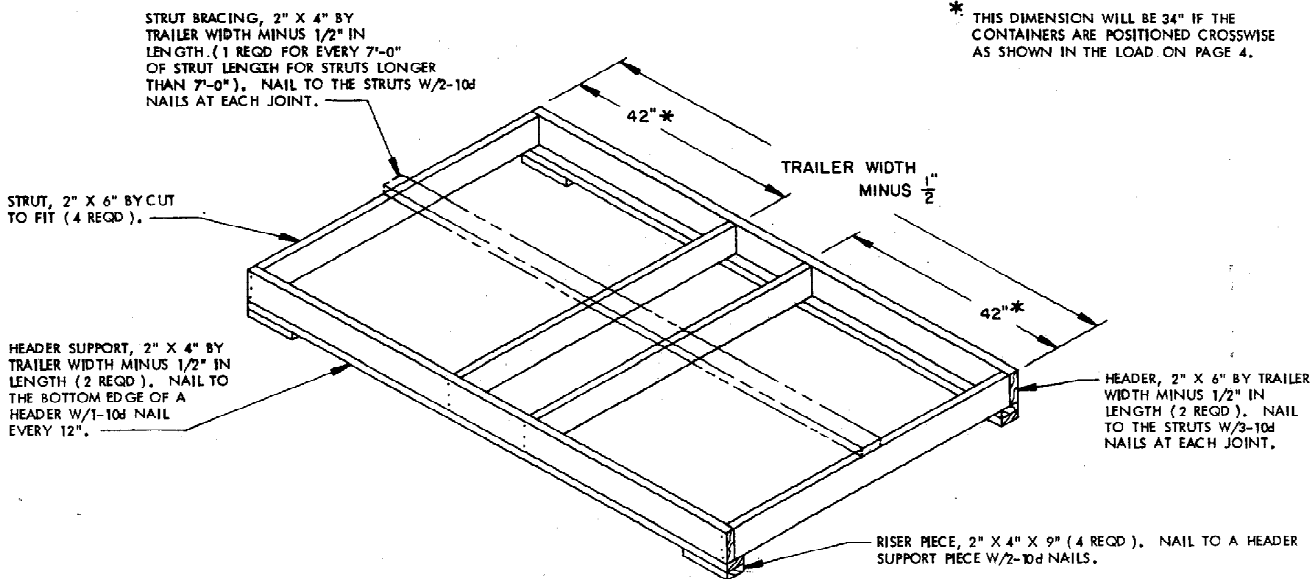

\* THIS DIMENSION WILL BE 34" IF THE CONTAINERS ARE POSITIONED CROSSWISE AS SHOWN IN THE LOAD ON PAGE 4.

**SPACER ASSEMBLY B**

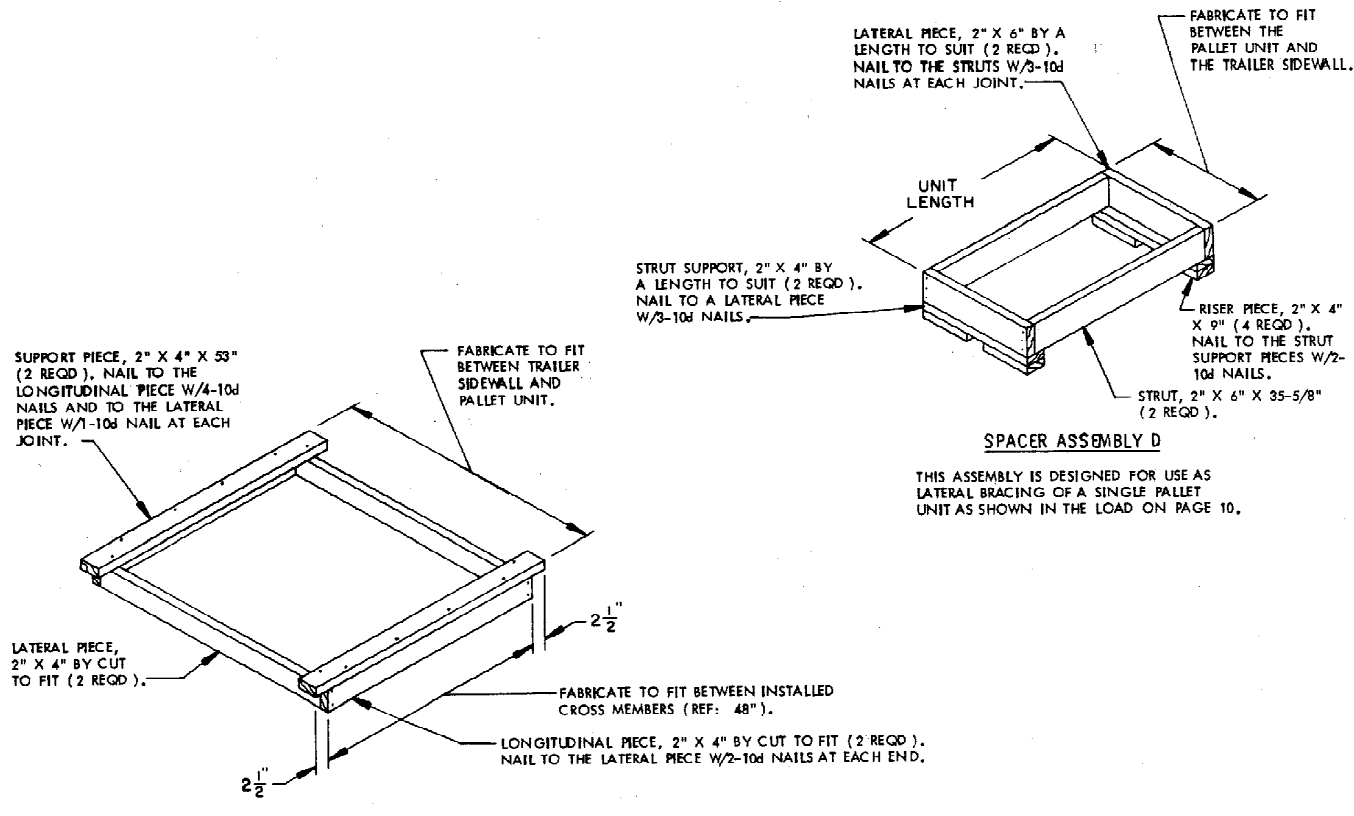

**SPACER ASSEMBLY D**

THIS ASSEMBLY IS DESIGNED FOR USE AS LATERAL BRACING OF A SINGLE PALLET UNIT AS SHOWN IN THE LOAD ON PAGE 10.

**SPACER ASSEMBLY C**

THIS ASSEMBLY IS DESIGNED FOR USE AS LATERAL BRACING IN A TRAILER EQUIPPED WITH MECHANICAL BRACING DEVICES.

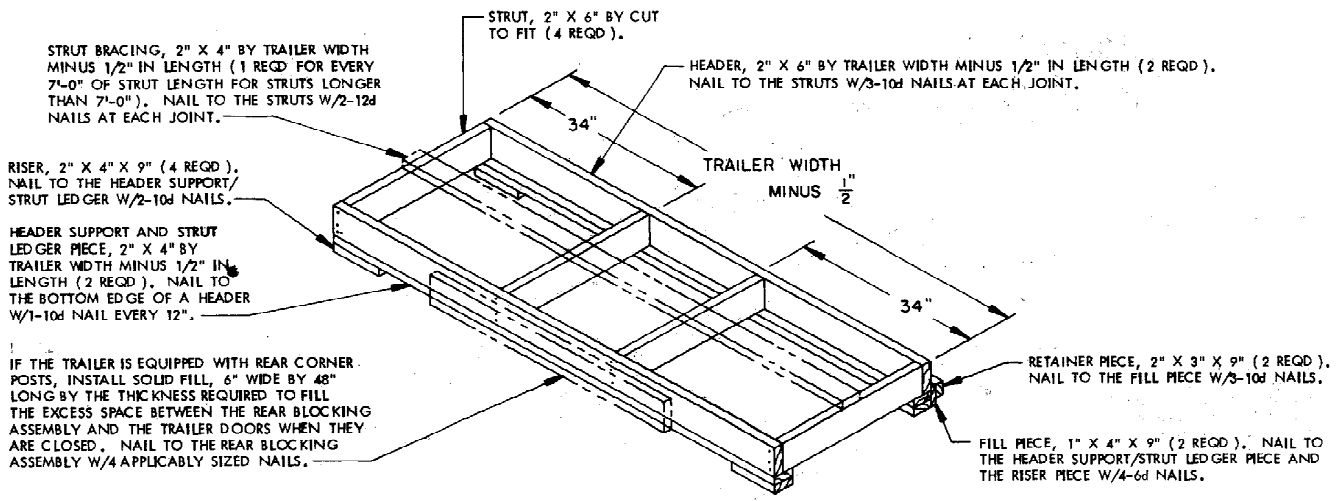

**REAR BLOCKING ASSEMBLY A**

THIS ASSEMBLY IS DESIGNED FOR USE AT THE REAR END OF CROSSWISE POSITIONED CONTAINERS WHEN THE SPACE BETWEEN THE LADING AND TRAILER DOORS IS GREATER THAN 9".

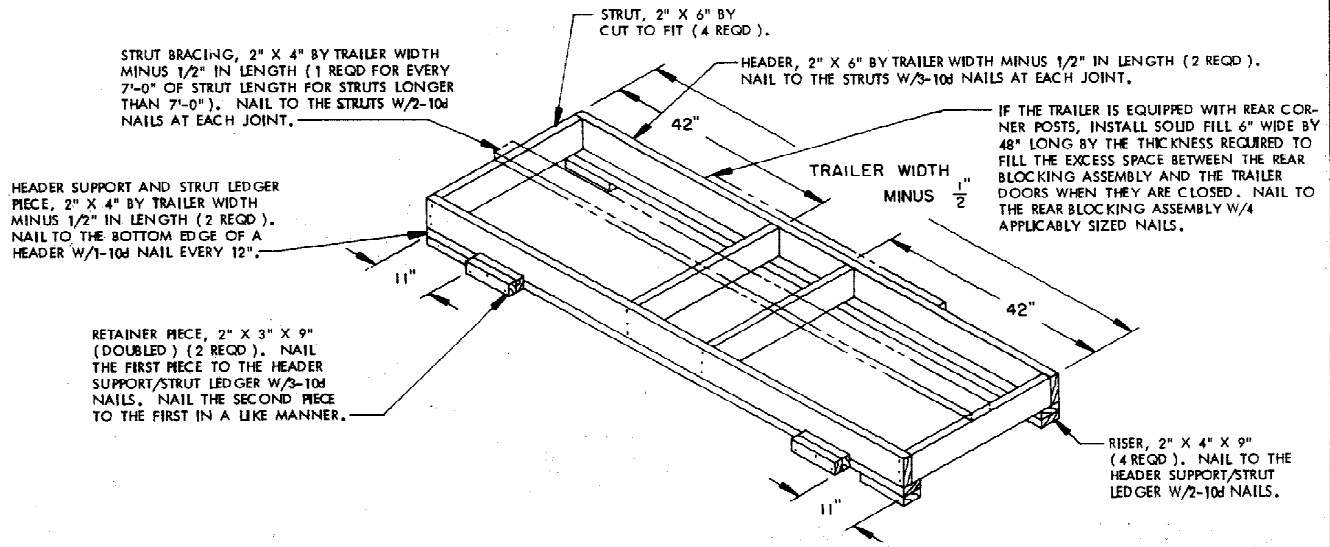

**REAR BLOCKING ASSEMBLY B**

THIS ASSEMBLY IS FOR USE AT THE REAR END OF LENGTHWISE POSITIONED CONTAINERS WHEN THE SPACE BETWEEN THE LADING AND THE TRAILER DOORS IS GREATER THAN 9". NOTE THAT THE ABOVE VIEW IS ROTATED 180° FROM THE POSITION IN WHICH IT WILL BE INSTALLED.

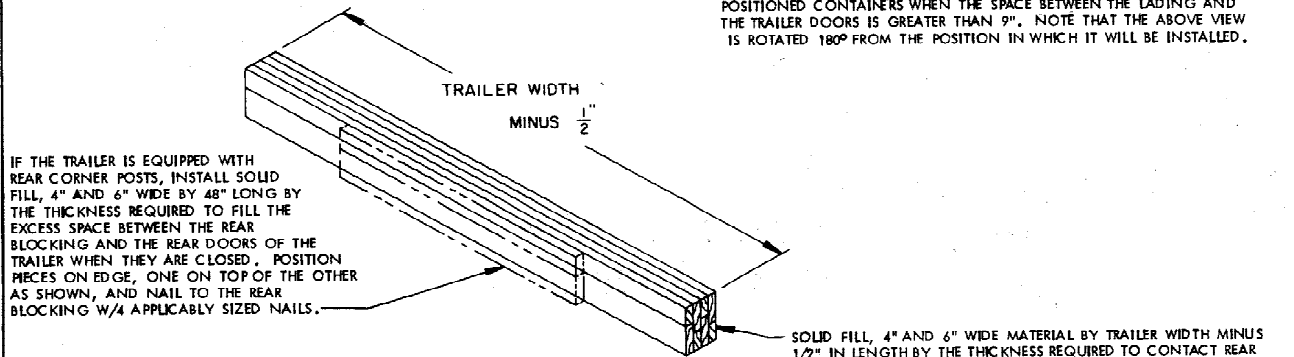

**REAR BLOCKING ASSEMBLY C**

THIS REAR BLOCKING IS DESIGNED FOR USE AT THE REAR END OF A LOAD WHEN THE SPACE BETWEEN THE LADING AND THE TRAILER DOORS IS LESS THAN 9".

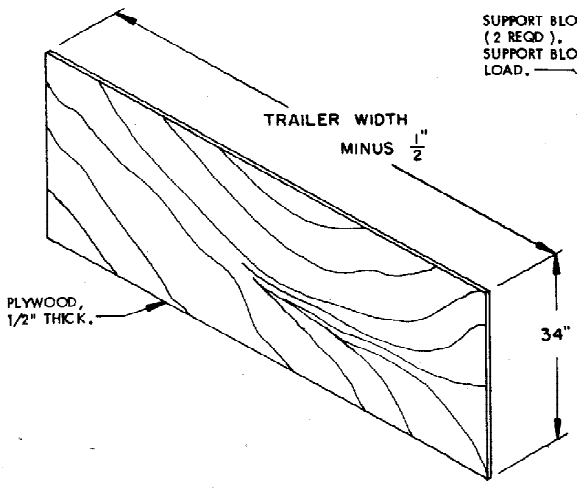

**LOAD BEARING GATE A**  
SEE "NOTE ●" BELOW.

SUPPORT BLOCK, 2" X 4" X 9"  
(2 REQD.). OMIT THE DOTTED  
SUPPORT BLOCK FOR A 2-WIDE  
LOAD.

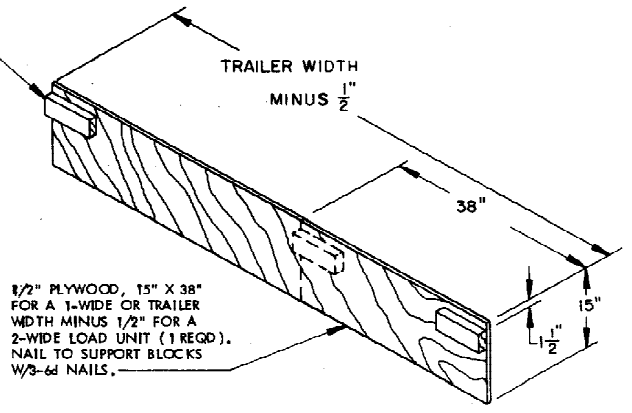

**LOAD BEARING GATE B**  
SEE "NOTE ●" BELOW.

**NOTE ●:**  
IF PLYWOOD IS NOT AVAILABLE, OR IF DESIRED, THE LOAD  
BEARING GATES MAY BE FABRICATED FROM NOMINAL ONE INCH AND/  
OR TWO INCH LUMBER. SEE THE ALTERNATIVE LOAD BEARING GATES  
BELOW.

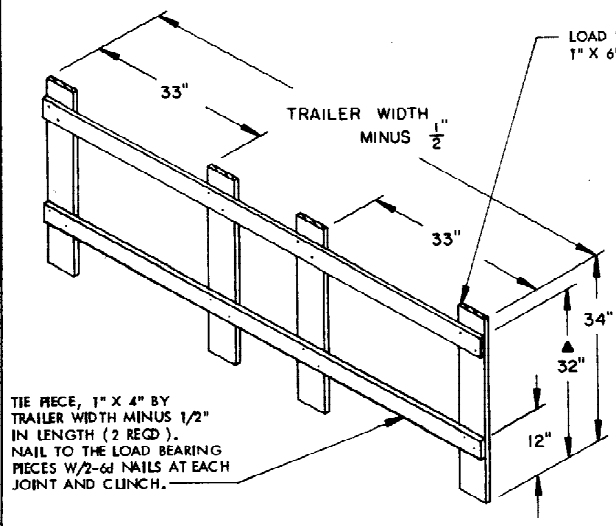

**ALTERNATIVE LOAD BEARING GATE A**

▲ THESE HEIGHTS MAY NEED TO BE ADJUSTED TO PROVIDE FOR CLEARANCE OF THE  
CROSS MEMBERS AT A MINUS TOLERANCE INSTALLATION.

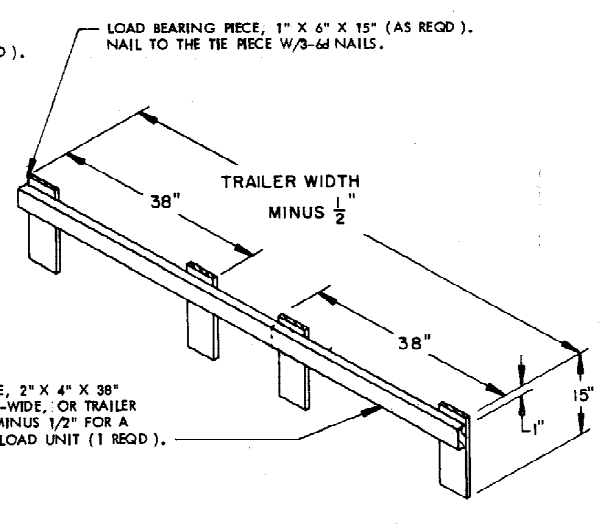

**ALTERNATIVE LOAD BEARING GATE B**

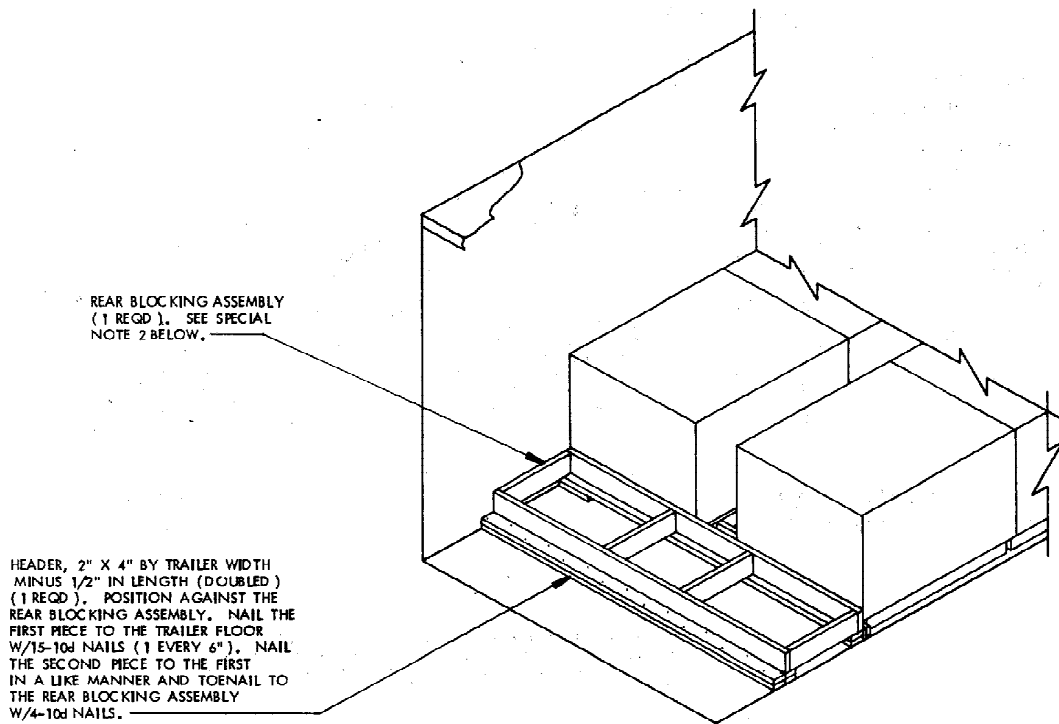

REAR BLOCKING ASSEMBLY  
(1 REQD). SEE SPECIAL  
NOTE 2 BELOW.

HEADER, 2" X 4" BY TRAILER WIDTH  
MINUS 1/2" IN LENGTH (DOUBLED)  
(1 REQD). POSITION AGAINST THE  
REAR BLOCKING ASSEMBLY. NAIL THE  
FIRST PIECE TO THE TRAILER FLOOR  
W/15-10d NAILS (1 EVERY 6"). NAIL  
THE SECOND PIECE TO THE FIRST  
IN A LIKE MANNER AND TOENAIL TO  
THE REAR BLOCKING ASSEMBLY  
W/4-10d NAILS.

#### NAILED-HEADER METHOD

#### SPECIAL NOTES:

1. THE NAILED-HEADER METHOD OF REAR BLOCKING DEPICTED ABOVE CAN ONLY BE USED IN TRAILERS HAVING A NAILABLE FLOOR AREA BETWEEN THE LADING AND THE METAL THRESHOLD, OR A THRESHOLD PLATE IF THE TRAILER IS SO EQUIPPED, OF AT LEAST FOURTEEN INCHES (14").
2. REAR BLOCKING ASSEMBLY "A" IS SHOWN FOR A TYPICAL INSTALLATION. CONSTRUCT THE ASSEMBLY USING 6" (MINIMUM) LONG STRUTS.
3. THE NAILED-HEADER METHOD OF REAR BLOCKING IS ADEQUATE FOR THE RETENTION OF THE MAXIMUM WEIGHT LOAD.
4. THE NAILED-HEADER METHOD, ALTHOUGH DESIGNED ESPECIALLY FOR TRAILERS HAVING ROLL-UP TYPE DOORS, MAY ALSO BE USED IN TRAILERS EQUIPPED WITH HINGED DOORS.

#### NAILED-HEADER METHOD

#### PROCEDURES FOR CONVENTIONAL VAN TRAILERS EQUIPPED WITH ROLL-UP TYPE DOORS

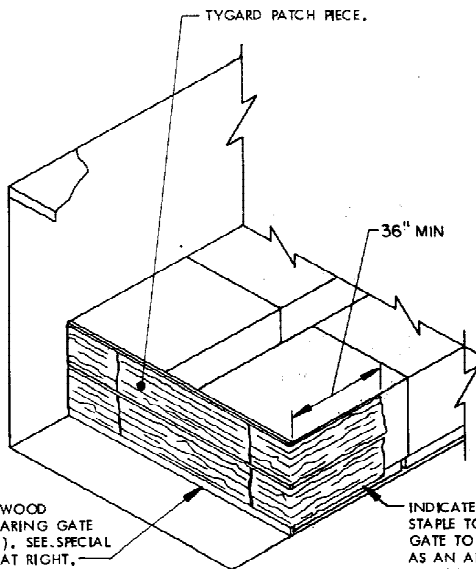

TYGARD METHOD A

RECOMMENDED EQUIPMENT/INSTALLATION PROCEDURES

EQUIPMENT REQUIRED

- PAINT ROLLER, LATEX
- PAINT ROLLER PAN
- TENSIONING ROD/TOOL
- PRESSURE ROLLER
- RATCHET WRENCH (12" TO 15" HANDLE)
- OPEN END OR BOX WRENCH (12" TO 15" HANDLE)
- SCISSORS OR KNIFE
- TYGARD (15" WIDE ROLL)
- TYGARD ADHESIVE

BASIC INSTALLATION GUIDANCE

1. CUT TO LENGTH THE REQUIRED NUMBER OF TYGARD PIECES (FROM 2 TO 8' DEPENDING UPON THE LOAD CONFIGURATION) FOR ATTACHMENT TO THE TRAILER SIDEWALL. PIECES WILL BE OF A LENGTH AS REQUIRED TO PROVIDE PROPER BONDING TO THE TRAILER SIDEWALL AND TO EXTEND 60" ACROSS THE REAR OF THE LOAD. ALSO, CUT 72" LONG "PATCH" PIECES OF TYGARD MATERIAL, ONE FOR EACH SET OF TWO PIECES PREVIOUSLY CUT.
2. PRIOR TO POSITIONING OF THE PALLETS IN THE REARMOST LOAD UNIT, APPLY TYGARD ADHESIVE TO THE PROPER PORTIONS OF THE TRAILER SIDEWALLS AND TO THE CORD SIDE OF A CORRESPONDING LENGTH OF EACH OF THE TYGARD PIECES THAT ARE TO BE ATTACHED TO THE SIDEWALLS OF THE TRAILER. ALLOW TIME FOR THE ADHESIVE TO "CURE" BEFORE PLACING A STRIP OF TYGARD ONTO A SIDEWALL (ADHESIVE WILL FEEL ALMOST DRY WHEN TOUCHED). NOTE: APPLICATION OF TYGARD IS SIMILAR TO THE APPLICATION OF "FORMICA".
3. APPLY THE TYGARD PIECES TO EACH SIDEWALL OF THE TRAILER SO THAT THE PIECES ARE PARALLEL OR NEARLY PARALLEL TO THE FLOOR. ROLL THE TYGARD WITH THE PRESSURE ROLLER TO ENSURE PROPER BONDING IS ACHIEVED. TEMPORARILY SECURE THE LOOSE ENDS TO THE TRAILER SIDEWALL OR TO AN OPEN HINGED TYPE DOOR OR TO THE OUTSIDE WALL, AS APPLICABLE.
4. POSITION THE PALLETS OF THE REARMOST LOAD UNIT INTO THE TRAILER AND INSTALL THE SPECIFIED ANTI-SWAY BRACES.
5. UNDO THE PREVIOUSLY SECURED LOOSE ENDS AND BRING A SET OF TWO PIECES TOGETHER ACROSS THE REAR OF THE LOAD. POSITION THE TENSIONING ROD SO THAT THE LOOSE ENDS OF THE TYGARD MATERIAL EXTEND THRU THE SLOT IN ROD. USING THE TWO WRENCHES, ROLL-UP THE TYGARD TO TENSION IT ACROSS REAR OF THE LOAD. POSITION A WRENCH SO AS TO MAINTAIN THE TENSION IN THE TYGARD PIECES. CUT OFF AND DISCARD EXCESS MATERIAL FROM ONE PIECE OF THE TYGARD.
6. APPLY TYGARD ADHESIVE TO THE TENSIONED TYGARD PIECES AND ALSO TO THE CORD SIDE OF THE PREVIOUSLY CUT "PATCH" PIECES. APPLY THE "PATCH" AND ROLL WITH THE PRESSURE ROLLER TO ENSURE PROPER BONDING.

SPECIAL NOTES:

1. THE TYGARD METHOD OF REAR BLOCKING DEPICTED, CAN ONLY BE USED IN TRAILERS WHICH HAVE REASONABLY SMOOTH AND ADEQUATELY SECURED SIDEWALL PANELS IN THE AREA WHERE THE TYGARD MATERIAL IS TO BE APPLIED. NOTE THAT TYGARD MATERIAL MUST BE INSTALLED AT TWO LEVELS ON THE REAR LOAD UNIT.
2. A 34" HIGH PLYWOOD GATE MUST BE INSTALLED AT THE REAR OF THE LOAD TO PROVIDE A SMOOTH SURFACE FOR THE TYGARD MATERIAL TO EXTEND AROUND. IF THE REAR LOAD UNIT IS 2-WIDE, INSTALL A GATE WHICH IS TRAILER WIDTH MINUS 1/2" IN LENGTH AS SHOWN BY THE "TYGARD METHOD A" DETAIL AT LEFT. IF THE REAR LOAD UNIT IS 1-WIDE, ROTATE THE PALLET, INSTALL ONE (1) PALLET WIDTH GATE, AND ONE (1) TRAILER WIDTH MINUS 1/2" IN LENGTH GATE, AS SHOWN BY THE "TYGARD METHOD B" DETAIL BELOW.
3. THE TYGARD MATERIAL AND THE ADHESIVE FOR ATTACHING IT ARE COMMERCIAL PRODUCTS. FOR A SOURCE OF SUPPLY, CONTACT WALNUT INDUSTRIES, INC., 1344 ADAMS ROAD, P.O. BOX "E", BENSALEM, PA 10920-0860, PHONE 1-800-523-6536. APPLICATION INSTRUCTIONS AND GUIDANCE CAN ALSO BE OBTAINED FROM THAT OFFICE.
4. THE TYGARD METHOD, ALTHOUGH ESPECIALLY FOR TRAILERS HAVING ROLL-UP TYPE DOORS, MAY ALSO BE USED IN TRAILERS EQUIPPED WITH HINGED DOORS.
5. NOTICE: IF THE AREA OF A SIDEWALL WHERE THE TYGARD SHOULD BE ATTACHED IS ROUGH AND/OR BROKEN, THE APPLICABLE PIECE (S) OF TYGARD CAN BE LENGTHENED A SUITABLE AMOUNT AND ATTACHED TO THE SIDEWALL AHEAD OF THE INDICATED PREFERRED LOCATION.

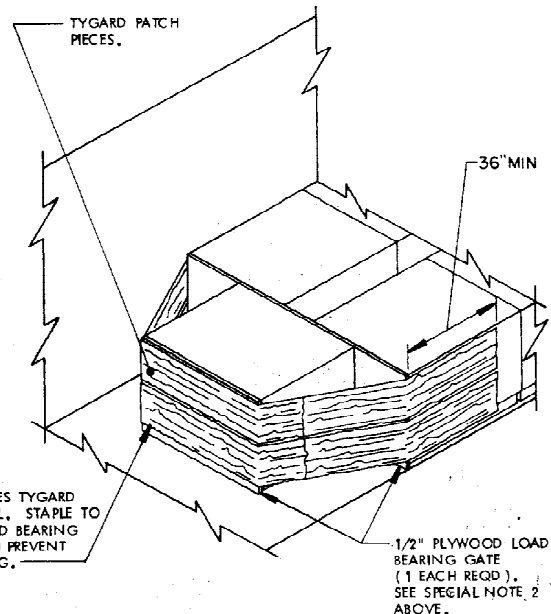

TYGARD METHOD B

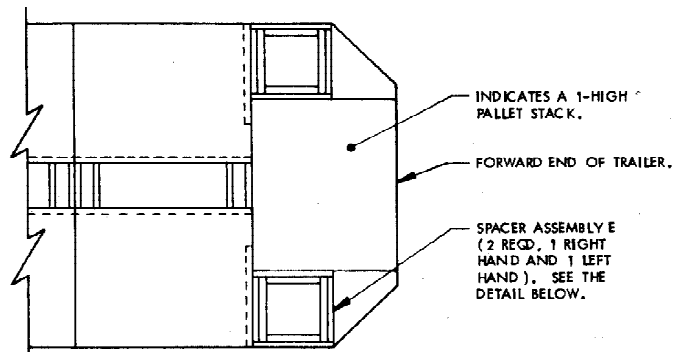

**ALTERNATIVE FORWARD LOADING PATTERN**

THIS PROCEDURE IS APPLICABLE TO THE LOADING OF ONE (1) PALLET UNIT IN THE FORWARD END OF A CONVENTIONAL VAN TRAILER HAVING LARGE ANGLED FRONT CORNERS (REF: 18"). THE PROCEDURES MAY ALSO BE USED IN TRAILERS HAVING SQUARE CORNERS, OR ROUNDED FRONT CORNERS, OR ANGLED CORNERS OF ANOTHER SIZE.

BUFFER PIECE, 2" X 6" BY A LENGTH TO SUIT (2 REQD). NAIL TO THE STRUTS W/3-10d NAILS AT EACH END.

RETAINER PIECE, 2" X 2" X 32" (1 REQD). NAIL TO THE RISER PIECE W/3-10d NAILS.

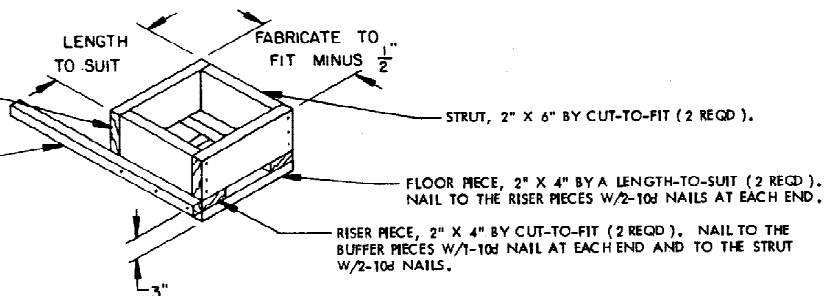

**SPACER ASSEMBLY E**

THIS ASSEMBLY IS DESIGNED FOR LATERAL BRACING OF A SINGLE PALLET UNIT WHICH IS TURNED 90° FROM THE NORMAL LOADING ORIENTATION AND POSITIONED IN THE FRONT OF AN ANGLED-CORNER CONVENTIONAL VAN TRAILER AS SHOWN IN THE "ALTERNATIVE LOADING PATTERN" VIEW ABOVE. RIGHT HAND AND LEFT HAND SPACER ASSEMBLIES ARE REQUIRED.