

APPENDIX 136

UNITIZATION PROCEDURES FOR MILITARY AMMUNITION AND COMPONENTS PACKED IN FIBERBOARD BOXES IN WIREBOUND OR FIBERBOARD 4-WAY ENTRY PALLET BOXES

INITIATOR, CARTRIDGE ACTUATED, PACKED 20 PER
FIBERBOARD BOX, UNITIZED 40 BOXES PER WIREBOUND
PALLET BOX (PALLET UNIT A) OR 48 BOXES PER
FIBERBOARD PALLET BOX (PALLET UNIT B);
APPROX BOX SIZE $8\frac{3}{8}$ " L X $8\frac{3}{8}$ " W X $14\frac{5}{8}$ " H

PALLET UNIT DATA								
ITEMS INCLUDED		HAZARD CLASSIFICATION (1)				WEIGHT (LBS)		
NSN	DODIC	DOT CLASS	CG CLASS	QD CLASS	COMP GROUP	UNIT A	UNIT B	
1377- 00-117-2795	M714	C	I	1.4	C	1,031	1,225	

(1) HAZARD CLASSIFICATION DATA CONTAINED IN THE ABOVE CHART IS FOR GUIDANCE AND INFORMATIONAL PURPOSES ONLY. VERIFICATION OF THE SPECIFIED DATA SHOULD BE MADE BY CONSULTING THE MOST RECENT JOINT HAZARD CLASSIFICATION SYSTEM LISTING OR OTHER APPROVED LISTING (S).

NOTICE: THIS APPENDIX CANNOT STAND ALONE BUT
MUST BE USED IN CONJUNCTION WITH THE BASIC
UNITIZATION PROCEDURES DRAWING 19-48-4169-20PA1006.

REVISIONS				DRAFTSMAN <i>dh</i>	PROJ ENG <i>LAF/WRE</i>
				CHECKER <i>[Signature]</i>	LOG BLDG OFFICE <i>[Signature]</i>
APPROVED, U.S. ARMY AMMUNITION, IDENTIFICATION AND OPERATIONAL DESIGNATION					
				<i>[Signature]</i>	<i>[Signature]</i>
DESIGN - SEE APPROVED BY OFFICE OF COMMANDING GENERAL, U.S. ARMY MATERIAL CENTER (AMC)					
				<i>William F. Ernst</i>	
U.S. ARMY DEFENSE AMMUNITION CENTER AND SCHOOL					
U.S. ARMY AMC DRAWING					
SEPTEMBER 1985					
CLASS	DIVISION	DRAWING	FILE		
19	48	4169/ 136	20PA 1006		

DO NOT SCALE

GENERAL NOTES

- A. THIS APPENDIX CANNOT STAND ALONE BUT MUST BE USED IN CONJUNCTION WITH THE BASIC UNITIZATION PROCEDURES DRAWING 19-48-4169-20PA1006. TO PRODUCE AN APPROVED UNIT LOAD, ALL PERTINENT PROCEDURES, SPECIFICATIONS AND CRITERIA SET FORTH WITHIN THE BASIC DRAWING WILL APPLY TO THE PROCEDURES DELINEATED IN THIS APPENDIX. ANY EXCEPTIONS TO THE BASIC PROCEDURES ARE SPECIFIED IN THIS APPENDIX.
- B. DIMENSIONS, CUBE AND WEIGHT OF A PALLET BOX UNIT WILL VARY SLIGHTLY DEPENDING UPON THE ACTUAL DIMENSIONS OF THE BOXES AND THE WEIGHT OF THE SPECIFIC ITEM BEING UNITIZED.
- C. OUTLOADING AND STORAGE OF THE ITEMS COVERED BY THIS APPENDIX SHALL BE ACCOMPLISHED IN ACCORDANCE WITH AMC (DARCOM) DRAWINGS IDENTIFIED WITHIN DA PAMPHLET 75-5.
- D. IF THE ITEMS COVERED HEREIN ARE UNITIZED PRIOR TO ISSUANCE OF THIS APPENDIX, THE BOXES NEED NOT BE REUNITIZED SOLELY TO CONFORM TO THIS APPENDIX.
- E. THE UNITIZATION PROCEDURES DEPICTED HEREIN MAY ALSO BE USED FOR UNITIZING CARTRIDGE ACTUATED INITIATORS WHEN IDENTIFIED BY DIFFERENT NATIONAL STOCK NUMBERS (NSN) THAN WHAT IS SHOWN ON THE TITLE PAGE, PROVIDED THE BOX PACK DOES NOT VARY FROM WHAT IS DELINEATED HEREIN. THE EXPLOSIVE CLASSIFICATION OF OTHER ITEMS MAY BE DIFFERENT THAN WHAT IS SHOWN.

LOAD STRAP, 3/4" X .035" OR .031" X 13'-4" LONG STEEL STRAPPING (1 REQD).
SEE SPECIAL NOTE 1 AT RIGHT.

SPECIAL NOTES:

1. THE LOAD STRAP MUST BE THREADED THROUGH THE STRAP SLOT OF THE PALLET. THE LOAD STRAP MUST BE TENSIONED AND SEALED PRIOR TO THE APPLICATION OF THE HORIZONTAL STRAP.
2. INSTALL THE HORIZONTAL STRAP TO ENIRCLE THE PALLET BOX UNIT AS SHOWN. THE HORIZONTAL STRAP MUST BE TENSIONED AND SEALED PRIOR TO APPLICATION OF TIEDOWN STRAPS.
3. INSTALL TIEDOWN STRAPS TO PASS UNDER THE TOP DECK BOARDS OF THE PALLET AND LOCATE AS SHOWN. TIEDOWN STRAPS MAY BE APPLIED BUT NOT TENSIONED UNTIL THE HORIZONTAL AND LOAD STRAPS HAVE BEEN INSTALLED, TENSIONED AND SEALED.

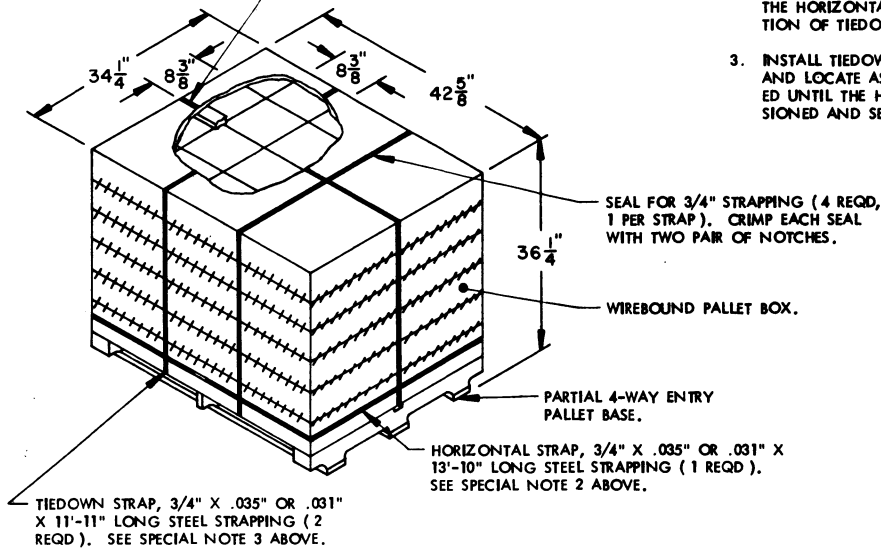

PALLET UNIT A

SEE GENERAL NOTE "B" ON PAGE 2.

40 BOXES OF INITIATORS (20 PER BOX) @ 23 LBS -----	920 LBS (APPROX)
DUNNAGE -----	4 LBS
WIREBOUND PALLET BOX -----	107 LBS

TOTAL WEIGHT ----- 1,031 LBS (APPROX)
CUBE ----- 30.6 CU FT (APPROX)

BILL OF MATERIAL (UNIT A)		
WIREBOUND PALLET BOX -----	1 REQD -----	107 LBS
STEEL STRAPPING, 3/4" -----	51.00' REQD -----	3.64 LBS
SEAL FOR 3/4" STRAPPING -----	4 REQD -----	NIL

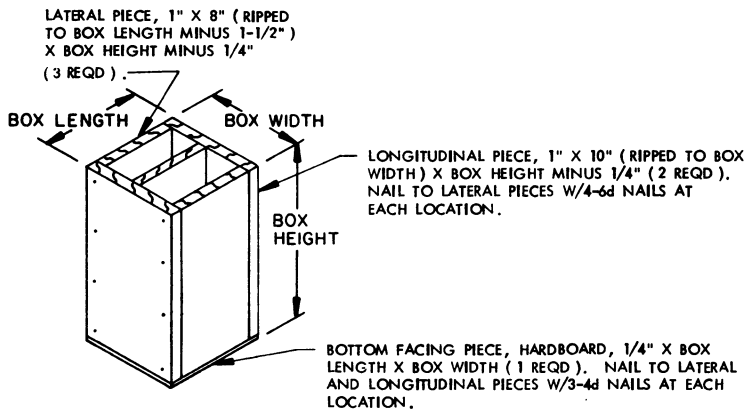

FILLER ASSEMBLY
(FOR MINUS ONE BOX)

FILLER PIECE, TRI-WALL FIBERBOARD,
1/2" X 16-3/4" X 33-1/2" (2 REQD).

FILLER PIECE, HARDBOARD,
1/4" X 44-1/2" X 33-1/2" (1 REQD).

TIEDOWN STRAP, 3/4" X .035" OR .031" X
12'-9" LONG STEEL STRAPPING (2 REQD).
SEE SPECIAL NOTE 2 AT RIGHT.

SEAL FOR 3/4" STRAPPING (4 REQD,
1 PER STRAP). CRIMP EACH SEAL
WITH TWO PAIR OF NOTCHES.

SPECIAL NOTES:

1. THE LOAD STRAPS MUST BE THREADED THROUGH THE STRAP SLOTS OF THE PALLET AS SHOWN. LOAD STRAPS MUST BE TENSIONED AND SEALED PRIOR TO APPLICATION OF TIEDOWN STRAPS.
2. INSTALL EACH TIEDOWN STRAP TO PASS UNDER THE TOP DECK BOARDS OF THE PALLET. TIEDOWN STRAPS MAY BE APPLIED BUT NOT TENSIONED UNTIL LOAD STRAPS HAVE BEEN INSTALLED, TENSIONED AND SEALED.

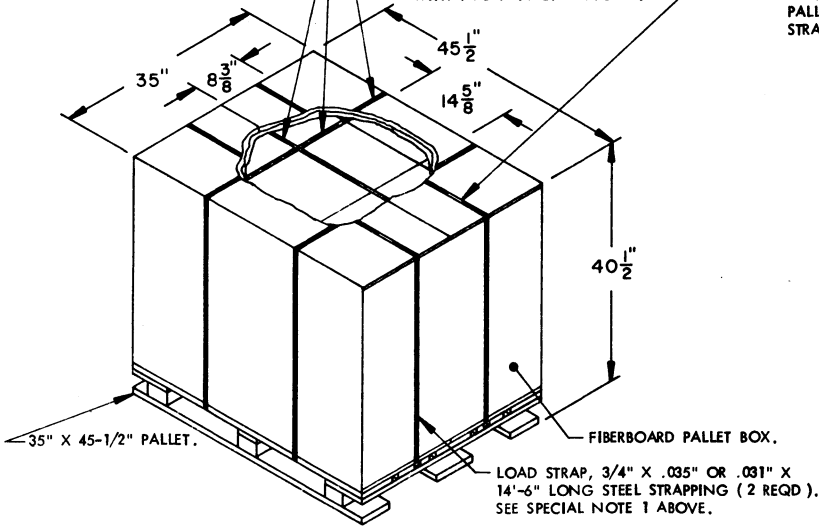

PALLET UNIT B

SEE GENERAL NOTE "B" ON PAGE 2.

48 BOXES OF INITIATORS (20 PER BOX) @ 23 LBS ----- 1,104 LBS (APPROX)
DUNNAGE ----- 17 LBS
FIBERBOARD PALLET BOX ----- 104 LBS

TOTAL WEIGHT ----- 1,225 LBS (APPROX)
CUBE ----- 37.3 CU FT (APPROX)

BILL OF MATERIAL (UNIT LOAD B)

FIBERBOARD PALLET BOX	1 REQD	104 LBS
STEEL STRAPPING, 3/4"	54.50' REQD	3.89 LBS
SEAL FOR 3/4" STRAPPING	4 REQD	NIL
HARDBOARD, 1/4"	10.35 SQ FT REQD	9.06 LBS
TRI-WALL FIBERBOARD, 1/2"	7.79 SQ FT REQD	3.52 LBS

