

APPENDIX 115

UNITIZATION PROCEDURES FOR MILITARY AMMUNITION AND COMPONENTS PACKED IN FIBERBOARD BOXES IN WIREBOUND OR FIBERBOARD 4-WAY ENTRY PALLET BOXES

ADAPTER KIT, FLARE DISPENSER, PACKED 4 PER
FIBERBOARD BOX, UNITIZED 60 BOXES PER
WIREBOUND PALLET BOX (PALLET UNIT A) OR 48
BOXES PER FIBERBOARD PALLET BOX (PALLET UNIT
B); APPROX BOX SIZE 11" L X 11" W X 10" H

PALLET UNIT DATA							
ITEMS INCLUDED		HAZARD CLASSIFICATION ①				WEIGHT (LBS)	WEIGHT (LBS)
NSN	DODIC	DOT CLASS	CG CLASS	QD CLASS	COMP GROUP	UNIT A	UNIT B
1370- 00-492-6920	LY15	—	—	—	—	609	510

REVISION

REVISION NO. 1, DATED AUGUST 1986, CONSISTS OF:
CHANGING BOX WEIGHT.

NOTICE: THIS APPENDIX CANNOT STAND ALONE BUT
MUST BE USED IN CONJUNCTION WITH THE BASIC
UNITIZATION PROCEDURES DRAWING 19-48-4169-20PA1006.

① HAZARD CLASSIFICATION DATA CONTAINED IN THE ABOVE CHART IS FOR GUIDANCE AND INFORMATIONAL PURPOSES ONLY. VERIFICATION OF THE SPECIFIED DATA SHOULD BE MADE BY CONSULTING THE MOST RECENT JOINT HAZARD CLASSIFICATION SYSTEM LISTING OR OTHER APPROVED LISTING (S).

NOTE: THIS DRAWING SUPERSEDES DRAWING 19-48-4116/118-20PA1002, DATED NOVEMBER 1981.

REVISIONS				DRAFTSMAN dh	PROJ ENG LAF/WJS	(MTR/LRT)
1	AUG 86	<i>[Signature]</i>	<i>[Signature]</i>	GEG	LOG ENGRG OFFICE W/IN of Base	
					APPROVED, U.S. ARMY ARMAMENT, MUNITIONS AND CHEMICAL COMMAND	
					APPROVED BY ORDER OF COMMANDING GENERAL, U.S. ARMY MUNITION COMMAND (AMC)	
					U.S. ARMY AMC DRAWING	
					SEPTEMBER 1985	
				CLASS	DIVISION	DRAWING
				19	48	4169/ 115
						FILE
						20PA 1006

DO NOT SCALE

GENERAL NOTES

- A. THIS APPENDIX CANNOT STAND ALONE BUT MUST BE USED IN CONJUNCTION WITH THE BASIC UNITIZATION PROCEDURES DRAWING 19-48-4169-20PA1006. TO PRODUCE AN APPROVED UNIT LOAD, ALL PERTINENT PROCEDURES, SPECIFICATIONS AND CRITERIA SET FORTH WITHIN THE BASIC DRAWING WILL APPLY TO THE PROCEDURES DELINEATED IN THIS APPENDIX. ANY EXCEPTIONS TO THE BASIC PROCEDURES ARE SPECIFIED IN THIS APPENDIX.
- B. DIMENSIONS, CUBE AND WEIGHT OF A PALLET BOX UNIT WILL VARY SLIGHTLY DEPENDING UPON THE ACTUAL DIMENSIONS OF THE BOXES AND THE WEIGHT OF THE SPECIFIC ITEM BEING UNITIZED.
- C. OUTLOADING AND STORAGE OF THE ITEMS COVERED BY THIS APPENDIX SHALL BE ACCOMPLISHED IN ACCORDANCE WITH AMC (DARCOM) DRAWINGS IDENTIFIED WITHIN DA PAMPHLET 75-5.
- D. IF THE ITEMS COVERED HEREIN ARE UNITIZED PRIOR TO ISSUANCE OF THIS APPENDIX, THE BOXES NEED NOT BE REUNITIZED SOLELY TO CONFORM TO THIS APPENDIX.
- E. THE UNITIZATION PROCEDURES DEPICTED HEREIN MAY ALSO BE USED FOR UNITIZING FLARE DISPENSER KITS WHEN IDENTIFIED BY DIFFERENT NATIONAL STOCK NUMBERS (NSN) THAN WHAT IS SHOWN ON THE TITLE PAGE, PROVIDED THE BOX PACK DOES NOT VARY FROM WHAT IS DELINEATED HEREIN. THE EXPLOSIVE CLASSIFICATION OF OTHER ITEMS MAY BE DIFFERENT THAN WHAT IS SHOWN.

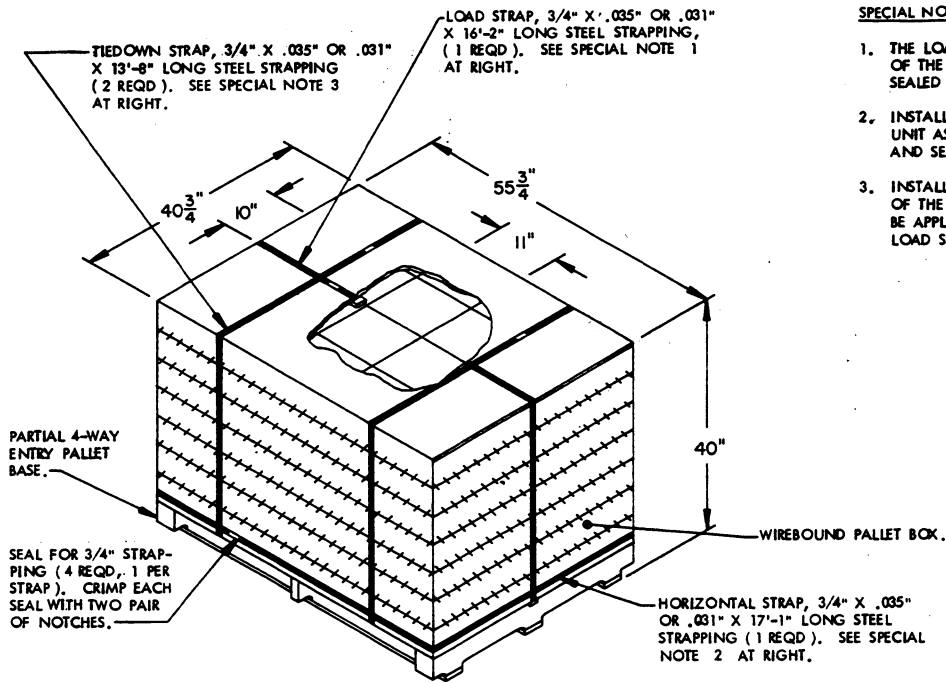

SPECIAL NOTES:

1. THE LOAD STRAP MUST BE THREADED THROUGH THE STRAP SLOT OF THE PALLET. THE LOAD STRAP MUST BE TENSIONED AND SEALED PRIOR TO THE APPLICATION OF THE HORIZONTAL STRAP.
2. INSTALL THE HORIZONTAL STRAP TO ENCIRCLE THE PALLET BOX UNIT AS SHOWN. THE HORIZONTAL STRAP MUST BE TENSIONED AND SEALED PRIOR TO APPLICATION OF TIEDOWN STRAPS.
3. INSTALL TIEDOWN STRAPS TO PASS UNDER THE TOP DECK BOARDS OF THE PALLET AND LOCATE AS SHOWN. TIEDOWN STRAPS MAY BE APPLIED BUT NOT TENSIONED UNTIL THE HORIZONTAL AND LOAD STRAPS HAVE BEEN INSTALLED, TENSIONED AND SEALED.

PALLET UNIT A

SEE GENERAL NOTE "B" ON PAGE 2.

60 BOXES OF FLARE DISPENSER KITS (4 PER BOX) @ 8 LBS	-----	480 LBS (APPROX)
DUNNAGE	-----	5 LBS
WIREBOUND PALLET BOX	-----	124 LBS
TOTAL WEIGHT	-----	609 LBS (APPROX)
CUBE	-----	52.6 CU FT (APPROX)

BILL OF MATERIAL (UNIT A)				
WIREBOUND PALLET BOX	-----	1 REQD	-----	124 LBS
STEEL STRAPPING, 3/4"	-----	60.58 REQD	-----	4.33 LBS
SEAL FOR 3/4" STRAPPING	-----	4 REQD	-----	NIL

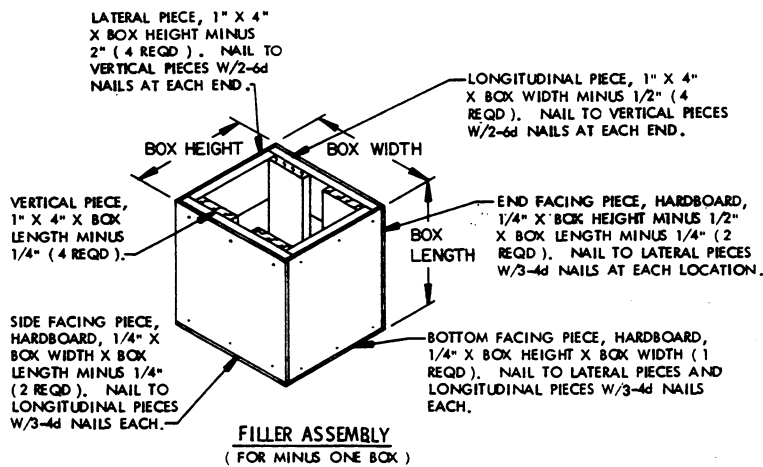

SPECIAL NOTES:

1. THE LOAD STRAPS MUST BE THREADED THROUGH THE STRAP SLOTS OF THE PALLET AS SHOWN. LOAD STRAPS MUST BE TENSIONED AND SEALED PRIOR TO APPLICATION OF TIEDOWN STRAPS.
2. INSTALL EACH TIEDOWN STRAP TO PASS UNDER THE TOP DECK BOARDS OF THE PALLET. TIEDOWN STRAPS MAY BE APPLIED BUT NOT TENSIONED UNTIL LOAD STRAPS HAVE BEEN INSTALLED, TENSIONED AND SEALED.

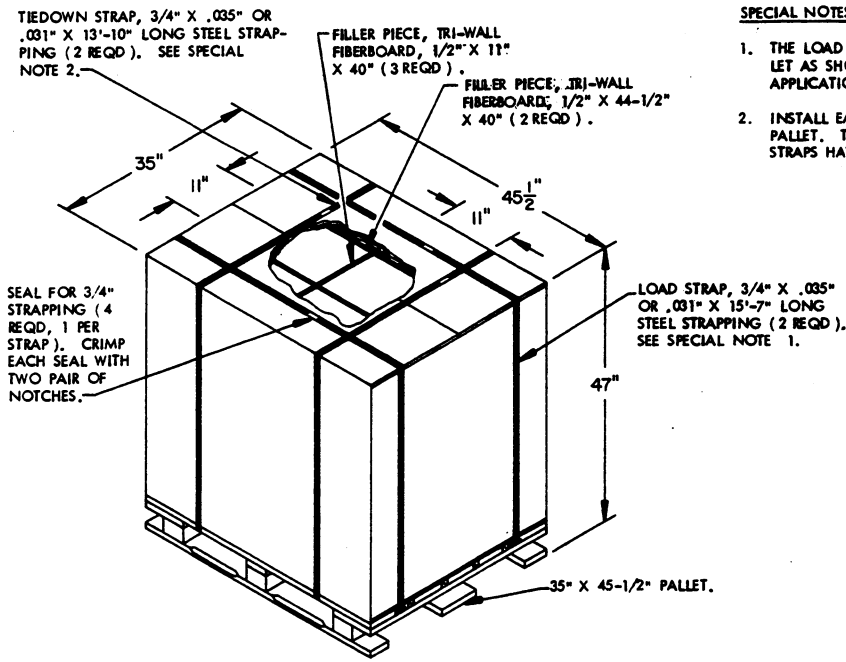

PALLET UNIT B

SEE GENERAL NOTE "B" ON PAGE 2.

48 BOXES OF FLARE DISPENSER KITS (4 PER BOX) @ 8 LBS -- 384 LBS. (APPROX)
 DUNNAGE ----- 20 LBS
 FIBERBOARD PALLET BOX ----- 106 LBS

TOTAL WEIGHT ----- 510 LBS (APPROX)
 CUBE ----- 43.3 CU FT. (APPROX)

BILL OF MATERIAL (UNIT B)

FIBERBOARD PALLET BOX	----- 1 REQD -----	106 LBS
STEEL STRAPPING, 3/4"	----- 58.83' REQD -----	4.20 LBS
SEAL FOR 3/4" STRAPPING	----- 4 REQD -----	N.L
TRI-WALLS, 1/2"	----- 33.89 SQ FT REQD --	15.32 LBS

