

REVISION NO. 2
 APPROVED BY
 BUREAU OF EXPLOSIVES

D. M. Hardy

DATE 1-11-96

LOADING AND BRACING WITH WOODEN DUNNAGE IN END OPENING ISO CONTAINERS OF PALLETIZED UNITS OF SEPARATE LOADING PROJECTILES

INDEX

ITEM	PAGE(S)
GENERAL NOTES AND MATERIAL SPECIFICATIONS	2,3
PALLET UNIT DETAILS	4,5
155MM SLP, 8/SMALL WOODEN PALLET CONTAINER LOAD	6,7
155MM SLP, 8/LARGE WOODEN PALLET CONTAINER LOAD	8,9
155MM SLP, 8 SHORT/METAL PALLET CONTAINER LOAD	10,11
155MM SLP, 8 TALL/METAL PALLET CONTAINER LOAD	12,13
8" SLP, 6 SHORT/WOODEN PALLET CONTAINER LOAD	14,15
8" SLP, 6 TALL/WOODEN PALLET CONTAINER LOAD	16-19
TYPICAL REDUCED LOAD PROVISIONS	20-21
DETAILS	22-27

- LOADING AND BRACING SPECIFICATIONS SET FORTH WITHIN THIS DRAWING ARE APPLICABLE TO LOADS THAT ARE TO BE SHIPPED BY TRAILER/CONTAINER-ON-FLATCAR (T/COFC) RAIL CARRIER SERVICE. THESE SPECIFICATIONS MAY ALSO BE USED FOR LOADS THAT ARE TO BE MOVED BY MOTOR OR WATER CARRIERS.

U.S. ARMY MATERIEL COMMAND DRAWING

APPROVED, U.S. ARMY INDUSTRIAL OPERATIONS COMMAND		DRAFTSMAN	TECHNICIAN	ENGINEER
<i>Daniel E. D'Archevick</i>		B. LEONARD		W. FRERICHS L. FIEFFER
APPROVED BY ORDER OF COMMANDING GENERAL, U.S. ARMY MATERIEL COMMAND		VALIDATION ENGINEERING DIVISION	TRANSPORTATION ENGINEERING DIVISION	LOGISTICS ENGINEERING OFFICE
<i>Angela C. King</i>		<i>J. K. ...</i>	<i>W. French</i>	<i>T. J. ...</i>
U.S. ARMY DEFENSE AMMUNITION CENTER AND SCHOOL		DECEMBER 1980		
REVISION NO. 2	DECEMBER 1995	CLASS	DIVISION	DRAWING
		19	48	4155
SEE THE REVISION LISTING ON PAGE 3				FILE
				15PE1001

DO NOT SCALE

GENERAL NOTES

(GENERAL NOTES CONTINUED)

- A. THIS DOCUMENT HAS BEEN PREPARED AND ISSUED IN ACCORDANCE WITH AR 740-1 AND AUGMENTS TM 743-200-1 (CHAPTER 5).
- B. THE SPECIFIED OUTLOADING PROCEDURES ARE APPLICABLE TO LOADS OF PALLETIZED SEPARATE LOADING PROJECTILES. SUBSEQUENT REFERENCE TO PALLET UNIT HEREIN MEANS THE PALLET UNIT WITH AMMUNITION ITEMS. SEE PAGES 4 AND 5 FOR DETAILS OF THE PALLET UNITS. CAUTION: REGARDLESS OF THE QUANTITY OF PALLET UNITS TO BE SHIPPED, THE "MAXIMUM GROSS WEIGHT" OF THE END OPENING ISO CONTAINER MUST NOT BE EXCEEDED.
- C. THE LOAD AS SHOWN IS BASED ON A 4,700 POUND 20' LONG BY 8' WIDE BY 8'-6" HIGH END OPENING ISO CONTAINER WITH INSIDE DIMENSIONS OF 19'-4" LONG BY 92" WIDE BY 93" HIGH, WITH A MAXIMUM GROSS WEIGHT OF 52,910 POUNDS. OLDER/OTHER CONTAINERS MAY HAVE A TOTAL INSIDE HEIGHT OF 95", BUT A CLEAR HEIGHT UNDER THE ROOF BOWS OF 93". VERIFY INSIDE CONTAINER HEIGHT PRIOR TO FABRICATING DUNNAGE. THE LOAD IS DESIGNED FOR TRAILER/CONTAINER-ON-FLATCAR (T/COFC) SHIPMENT, HOWEVER, THE LOAD AS DESIGNED CAN ALSO BE MOVED BY OTHER SURFACE MODES OF TRANSPORT. NOTICE: OTHER CONTAINERS OF THE SAME DESIGN CONFIGURATION CAN BE USED.
- D. WHEN LOADING PALLET UNITS, THEY ARE TO BE POSITIONED SO AS TO ACHIEVE A TIGHT LOAD (TIGHT AGAINST THE DUNNAGE ASSEMBLIES). THE UNBLOCKED SPACE ACROSS THE WIDTH OF A LOAD BAY IS NOT TO EXCEED 1-1/2". EXCESSIVE SLACK CAN BE ELIMINATED FROM A LOAD BY LAMINATING ADDITIONAL PIECES OF APPROPRIATE THICKNESS TO THE SPACER PIECES ON THE SIDE FILL ASSEMBLIES. NAIL EACH ADDITIONAL PIECE W/1 APPROPRIATELY SIZED NAIL EVERY 12". ADDITIONALLY, THE THICKNESS AND/OR QUANTITY OF THE PLYWOOD OR SPACER PIECES IN THE SIDE FILL ASSEMBLIES OR SEPARATOR GATES MAY BE ADJUSTED AS REQUIRED TO FACILITATE VARIANCE IN THE SIZE OF THE PALLET UNITS.
- E. DUNNAGE LUMBER SPECIFIED IS OF NOMINAL SIZE. FOR EXAMPLE, 1" X 4" MATERIAL IS ACTUALLY 3/4" THICK BY 3-1/2" WIDE AND 2" X 6" MATERIAL IS ACTUALLY 1-1/2" THICK BY 5-1/2" WIDE.
- F. A STAGGERED NAILING PATTERN WILL BE USED WHENEVER POSSIBLE WHEN NAILS ARE DRIVEN INTO JOINTS OF DUNNAGE ASSEMBLIES OR WHEN LAMINATING DUNNAGE. ADDITIONALLY, THE NAILING PATTERN FOR AN UPPER PIECE OF LAMINATED DUNNAGE WILL BE ADJUSTED AS REQUIRED SO THAT A NAIL FOR THAT PIECE WILL NOT BE DRIVEN THROUGH ONTO OR RIGHT BESIDE A NAIL IN A LOWER PIECE.

(CONTINUED AT RIGHT)

- G. IN SOME CONTAINERS THERE IS A SLOT AT THE CORNERS OF THE FORWARD WALL. PIECES OF DUNNAGE MATERIAL MUST BE LAMINATED TO THE BUFFER PIECES ON THE FORWARD BLOCKING ASSEMBLY TO PROVIDE A FLAT SURFACE FOR THE BUFFER PIECES. A PIECE OF 2" X 4", 2" X 3" OR A SPECIAL WIDTH PIECE CUT-TO-FIT CAN BE USED. THIS FILL PIECE WILL BE NAILED WITH ONE APPROPRIATELY SIZED NAIL EVERY 12". NOTE THAT SOME CONTAINERS ARE EQUIPPED WITH "TIE-BARS" IN THE CORNER SLOT, WHICH PRECLUDE THE USE OF A FULL HEIGHT FILL PIECE. WHEN "TIE-BARS" ARE PRESENT, THE FILL PIECE MUST BE INSTALLED IN SEGMENTS DESIGNED TO FIT BETWEEN THE "TIE-BARS" VERTICALLY. THE FILL PIECE(S) IS NOT REQUIRED WHEN THE CORNER PORTIONS OF THE CONTAINER FORWARD WALL ARE SMOOTH AND FLAT. DO NOT ALLOW ANY DUNNAGE ASSEMBLY TO CONTACT THE CONTAINER FORWARD WALL, ONLY THE CORNER POSTS OF THE CONTAINER SHOULD BE USED FOR FORWARD LONGITUDINAL BLOCKING.
- H. WHETHER A CONTAINER IS FULL OR IS LOADED WITH A REDUCED QUANTITY OF LADING UNITS, THE LENGTHWISE CENTER OF GRAVITY OF THE LOAD MUST BE WITHIN 12", IN EITHER DIRECTION, OF THE MID-POINT OF THE CONTAINER.
- J. CAUTION: DO NOT NAIL DUNNAGE MATERIAL TO THE CONTAINER WALLS OR FLOOR. ALL NAILING WILL BE WITHIN THE DUNNAGE.
- K. PORTIONS OF THE CONTAINER DEPICTED WITHIN THIS DRAWING, SUCH AS THE SIDEWALL, HAVE NOT BEEN SHOWN IN THE LOAD VIEWS FOR CLARITY PURPOSES.
- L. MAXIMUM LOAD WEIGHT CRITERIA:
 THE MAXIMUM LOAD WEIGHTS ARE CONTROLLED BY EQUIPMENT CAPABILITY FACTORS. ALTHOUGH THE HEAVIEST MAXIMUM LOADS ARE DELINEATED IN THE LOAD VIEWS, PROVISIONS ARE INCLUDED WITHIN THIS DRAWING SO THAT THE BASIC LOADS CAN BE ADJUSTED TO SATISFY A LESSER QUANTITY OF LADING UNITS. DEPENDING ON TRANSPORTATION ROUTING, IT MAY BE NECESSARY TO REDUCE THE LOAD WEIGHT TO SATISFY "WEIGHT LAWS" OF CERTAIN STATES. ALSO, IT MAY BE NECESSARY TO REDUCE THE LOAD WEIGHT TO SATISFY OTHER WEIGHT RESTRICTIONS IMPOSED ON THE INTERMODAL CONTAINER SYSTEM.
- M. REQUIREMENTS CITED WITHIN THE BUREAU OF EXPLOSIVES PAMPHLET 6C APPLY WHEN THE SHIPMENT MOVES BY TRAILER/CONTAINER-ON-FLATCAR (T/COFC). SPECIAL T/COFC NOTES FOLLOW:
 1. A LOADED CONTAINER MUST BE ON A CHASSIS EQUIPPED WITH TWO BOGIE ASSEMBLIES WHEN BEING MOVED IN TOFC SERVICE.
 2. THE LOAD LIMIT OF A T/COFC RAILCAR MUST NOT BE EXCEEDED, NOR WILL A CAR BE LOADED SO THAT THE TRUCK UNDER ONE END OF THE CAR CARRIES MORE THAN ONE-HALF OF THE LOAD LIMIT FOR THAT CAR.

- N. DURING INTRASTATE AND/OR INTERSTATE MOVES BY MOTOR CARRIER, A PROPER CHASSIS OR MODIFIED FLATBED TRAILER MUST BE USED TO PRECLUDE VIOLATION OF ONE OR MORE "WEIGHT LAWS" APPLICABLE TO THE STATE OR STATES INVOLVED.

- O. CONVERSION TO METRIC EQUIVALENTS: DIMENSIONS WITHIN THIS DOCUMENT ARE EXPRESSED IN INCHES AND WEIGHTS ARE EXPRESSED IN POUNDS. WHEN NECESSARY, THE METRIC EQUIVALENTS MAY BE COMPUTED ON THE BASIS OF ONE INCH EQUALS 25.4 MM AND ONE POUND EQUALS 0.454 KG.

- P. THE QUANTITY OF PALLET UNITS SHOWN IN THE LOADS MAY BE REDUCED FOR SHIPMENT, IF DESIRED. SEE THE OMITTED UNIT ASSEMBLY ON PAGE 24 AND THE "TYPICAL REDUCED LOAD PROVISIONS" ON PAGE 20.
 1. IF A LOAD IS REDUCED BY ONLY A SMALL AMOUNT, LADING UNITS NORMALLY MAY BE ELIMINATED FROM THE CENTER OF THE LOAD.
 2. IF A LOAD IS REDUCED BY A LARGE AMOUNT, LADING UNITS SHOULD BE ELIMINATED AS REQUIRED AND THE TOTAL LOAD SHIFTED FORE OR AFT, AS NECESSARY, TO ACHIEVE A SYMMETRICAL WEIGHT DISTRIBUTION. THE DEPICTED PROCEDURES WILL BE FOLLOWED AS CLOSELY AS POSSIBLE, MAKING ONLY THOSE ADJUSTMENTS TO THE DUNNAGE WHICH ARE REQUIRED TO ACCOMMODATE THE NUMBER OF UNITS TO BE SHIPPED.

(CONTINUED ON PAGE 3)

MATERIAL SPECIFICATIONS

- LUMBER - - - - - : SEE TM 743-200-1 (DUNNAGE LUMBER) AND FED SPEC MM-L-751.
- NAILS - - - - - : FED SPEC FF-N-105; COMMON.
- PLYWOOD - - - - - : COMMERCIAL ITEM DESCRIPTION A-A-55057, TYPE A, CONSTRUCTION AND INDUSTRIAL PLYWOOD, INTERIOR WITH EXTERIOR GLUE, GRADE C-D. IF SPECIFIED GRADE IS NOT AVAILABLE, A BETTER INTERIOR OR AN EXTERIOR GRADE MAY BE SUBSTITUTED.
- WIRE, CARBON STEEL - : ASTM A853; ANNEALED AT FINISH, BLACK OXIDE FINISH, .0800" DIA, GRADE 1006 OR BETTER.
- STRAPPING, STEEL - - : ASTM D3953; FLAT STRAPPING, TYPE 1, HEAVY DUTY, FINISH A, B (GRADE 2), OR C.
- SEAL, STRAP - - - - : ASTM D3953; CLASS H, FINISH A, B (GRADE 2), OR C, DOUBLE NOTCH TYPE, STYLE I, II, OR IV.
- STEEL, STRUCTURAL - : ASTM A501, STEEL STRUCTURAL TUBING; AND ASTM A570, STEEL, STRIP, HOT-ROLLED, GRADE 36 (MINIMUM).

REVISIONS

- Q. THE 4" X 4" STRUTS DEPICTED IN LOADS WITHIN THIS DRAWING ARE CAPABLE OF SUPPORTING 5,000 POUNDS EACH. FOR EXAMPLE, IF A LOAD OF 30 PALLET UNITS IS STRUTTED AT THE FORWARD END OF THE CONTAINER, AND EACH PALLET UNIT WEIGHS 1,250 POUNDS, EIGHT STRUTS ARE REQUIRED (37,500 POUNDS DIVIDED BY 5,000 POUNDS EQUATES TO EIGHT STRUTS). THE QUANTITY OF STRUTS REQUIRED IS NOT SOLELY DETERMINED BY THE WEIGHT OF THE LOAD. THE LADING UNITS MUST BE FULLY SUPPORTED AND BLOCKED ONLY AGAINST SECTIONS THAT ARE STRONG ENOUGH TO SUPPORT THE FULL LOAD. FOR EXAMPLE, DO NOT ALIGN ONE STRUT WITH A PALLET COVER ASSEMBLY WITHOUT HAVING A RESPECTIVE STRUT ALIGNED WITH THE PALLET BASE ASSEMBLY.
- R. LOAD-BLOCKING STRUTS WHICH ARE 48" OR LONGER MUST BE STIFFENED BY THE APPLICATION OF HORIZONTAL AND VERTICAL STRUT BRACING AS SHOWN BY KEY NUMBERS ③ AND ④ ON PAGE 20. BRACING IS NOT REQUIRED IF THE STRUTS FOR THE LOAD BEING SHIPPED ARE SHORTER THAN 48". THE LENGTH OF THE LOAD-BLOCKING STRUTS SHOULD BE KEPT AS SHORT AS POSSIBLE (APPROX 18" MINIMUM), BUT IN THE EVENT IT IS NECESSARY TO USE STRUTS WHICH ARE 8'-0" OR MORE IN LENGTH, IT WILL BE NECESSARY TO APPLY AN ADDITIONAL SET OF HORIZONTAL AND VERTICAL STRUT BRACING PIECES. STRUT BRACING SHOULD BE APPLIED SO AS TO PROVIDE NEARLY EQUAL SPACES BETWEEN THE BRACING PIECES AND THE ENDS OF THE STRUTS AND/OR BETWEEN ADJACENT STRUT BRACING PIECES.
- S. ALTHOUGH PROCEDURES FOR A 3-PROJECTILE PALLET UNIT OF 8" SEPARATE LOADING PROJECTILES HAVE NOT BEEN SHOWN, THE PROCEDURES DELINEATED ON PAGES 14 AND 15 FOR A 6-PROJECTILE PALLET UNIT MAY BE USED BY STRAPPING TWO OF THE 3-PROJECTILE PALLET UNITS TOGETHER USING TWO STRAPS, 1-1/4" WIDE, AND ONE OR TWO SEALS. SEE THE "END-OVER-END LAP JOINT DETAILS" BELOW.
- T. IF 2" X 3" DUNNAGE LUMBER IS NOT READILY AVAILABLE, TWO ACCEPTABLE SIZE 2" X 3" PIECES CAN BE MADE BY RIPPING (SAWING) A PIECE OF NOMINAL SIZE 2" X 6" LUMBER ONE THE CENTER LINE OF ITS 5-1/2" WIDTH.
- U. TO FACILITATE INSTALLATION, THE FINAL ASSEMBLY OF THE FORWARD OR REAR BLOCKING ASSEMBLIES MAY BE ACCOMPLISHED WITHIN THE END OPENING CONTAINER. THE BUFFER PIECES (AND FILL PIECES FOR THE FORWARD BLOCKING ASSEMBLY) MAY BE NAILED TO THE BOX BEAMS AFTER FIRST POSITIONING THE INDIVIDUAL BOX BEAMS WITHIN THE CONTAINER. CARE MUST BE EXERCISED TO ENSURE THAT THE BOX BEAMS ARE INSTALLED AT THE CORRECT HEIGHT AND THAT THE FORWARD AND REAR BLOCKING ASSEMBLIES ARE CENTERED ON THE LOAD. THE REAR BLOCKING ASSEMBLY MAY BE ASSEMBLED AFTER ALL PALLET UNITS ARE LOADED, OR AFTER PARTIAL LOADING IS COMPLETED (THE ASSEMBLY MAY BE POSITIONED ON TOP OF LOADED PALLET TEMPORARILY).

- REVISION NO. 1, DATED NOVEMBER 1984, CONSISTS OF:
1. ADDING PROCEDURES FOR AN ADDITIONAL PALLET UNIT.
 2. UPDATING THE DRAWING FORMAT.
- REVISION NO. 2, DATED DECEMBER 1995, CONSISTS OF:
1. ADDING PROCEDURES FOR TWO ADDITIONAL PALLET UNITS.
 2. DELETING PROCEDURES FOR TWO OBSOLESCENT PALLET UNITS.
 3. STREAMLINING/ECONOMIZING THE PROCEDURES.

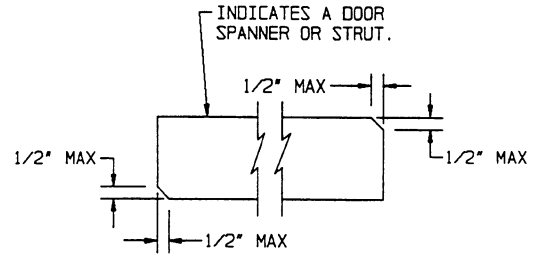

BEVEL-CUT

IF DESIRED, EACH END OF A DOOR SPANNER PIECE OR STRUT MAY BE BEVEL-CUT AS SHOWN ABOVE TO FACILITATE THE ACHIEVEMENT OF A TIGHT DOOR-POST-TO-DOOR-POST OR REAR OF LOAD FIT.

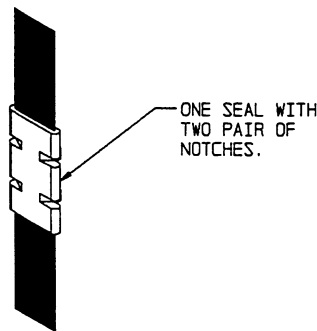

STRAP JOINT A

METHOD OF SECURING A STRAP JOINT WHEN USING A NOTCH-TYPE SEALER.

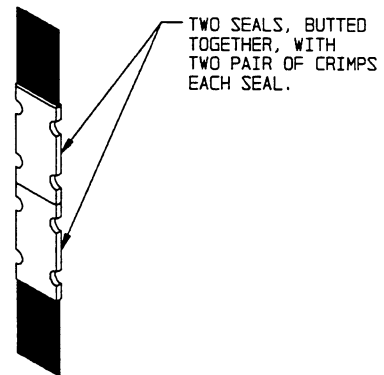

STRAP JOINT B

METHOD OF SECURING A STRAP JOINT WHEN USING A CRIMP-TYPE SEALER.

END-OVER-END LAP JOINT DETAILS

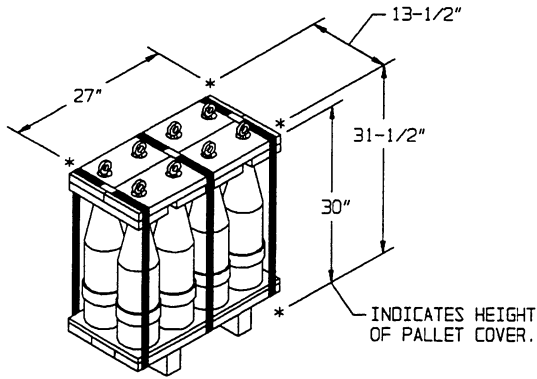

155MM SLP, 8/SMALL WOODEN PALLET

UNIT WEIGHT ----- 800 LBS (APPROX)
 CUBE ----- 6.6 CU FT

REFER TO THE LOAD ON PAGE 6

INCLUDES, BUT IS NOT LIMITED TO DODICS:
 D505, D506, D542, D544, D545, D547, D548, D549,
 D550, D551, D554, D561, D562, D568, AND D571

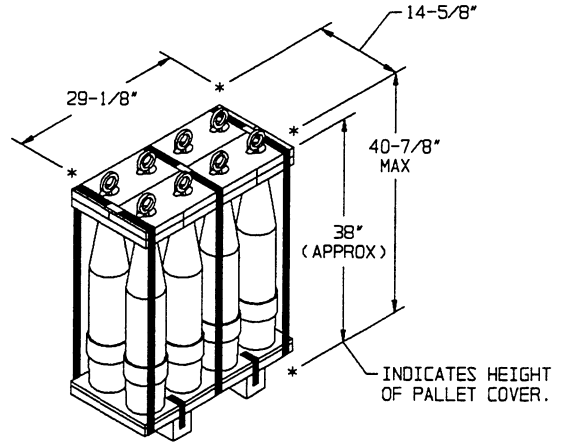

155MM SLP, 8/LARGE WOODEN PALLET

UNIT WEIGHT ----- 874 LBS (APPROX)
 CUBE ----- 9.7 CU FT

REFER TO THE LOAD ON PAGE 8

INCLUDES, BUT IS NOT LIMITED TO DODICS:
 D273, D501, D502, D503, D509, D514, D515, D528,
 D529, D563, D579, AND D864

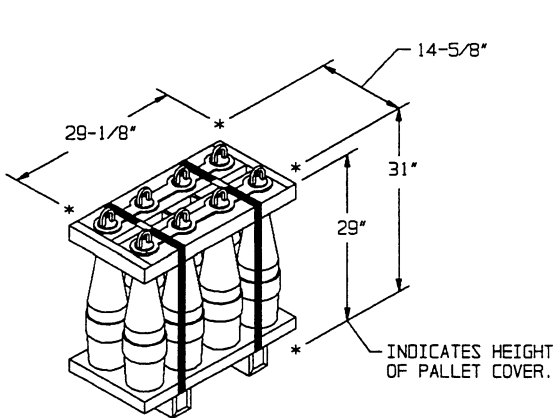

155MM SLP, 8 SHORT/METAL PALLET

UNIT WEIGHT ----- 857 LBS (APPROX)
 CUBE ----- 7.7 CU FT

REFER TO THE LOAD ON PAGE 10

INCLUDES, BUT IS NOT LIMITED TO DODICS:
 D513, D544, D550, AND D561

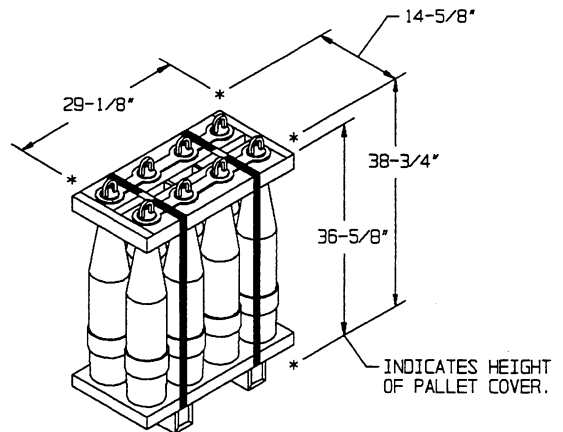

155MM SLP, 8 TALL/METAL PALLET

UNIT WEIGHT ----- 897 LBS (APPROX)
 CUBE ----- 9.6 CU FT

REFER TO THE LOAD ON PAGE 12

INCLUDES, BUT IS NOT LIMITED TO DODICS:
 D501, D502, D503, D505, D509, D514, D515, D528,
 D563, AND D864

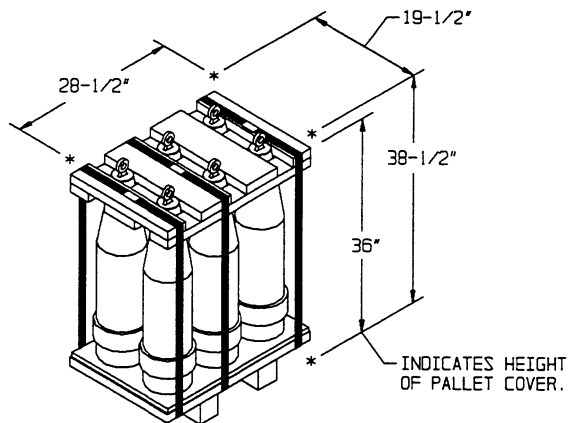

8" SLP, 6 SHORT/WOODEN PALLET

UNIT WEIGHT ----- 1,256 LBS (APPROX)
 CUBE ----- 12.4 CU FT

REFER TO THE LOAD ON PAGE 14

INCLUDES, BUT IS NOT LIMITED TO DODICS:
 D649, D651, D680, AND D684

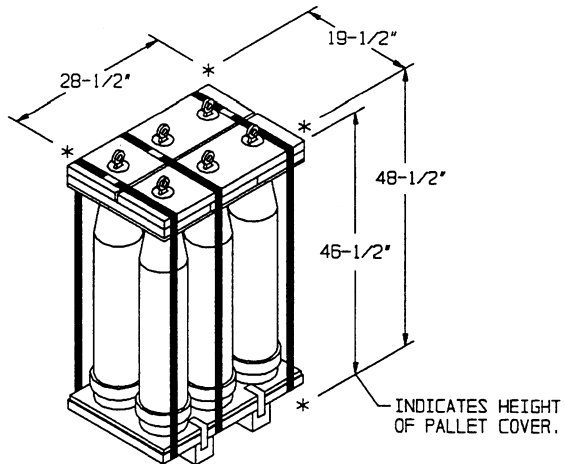

8" SLP, 6 TALL/WOODEN PALLET

UNIT WEIGHT ----- 1,296 LBS (APPROX)
 CUBE ----- 15.6 CU FT

REFER TO THE LOAD ON PAGE 16

INCLUDES, BUT IS NOT LIMITED TO DODICS:
 D624 AND D651

INDICATES BUNDLING STRAP. SEE SPECIAL NOTE 4 ON PAGE 7.

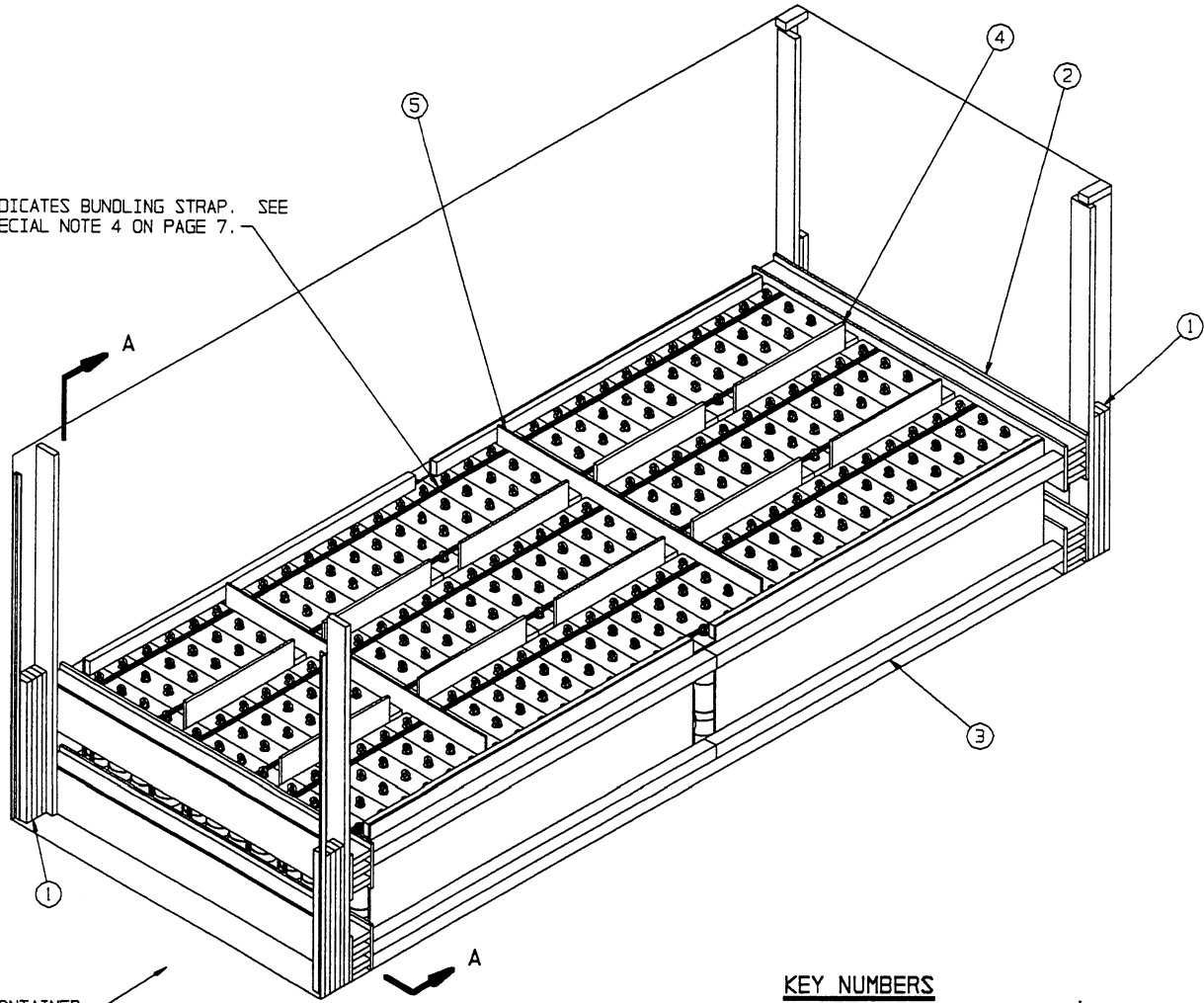

ISOMETRIC VIEW

KEY NUMBERS

- ① FILL MATERIAL, 4" WIDE BY 36" LONG MATERIAL (AS REQD). NAIL THE FIRST PIECE TO THE FORWARD/REAR BLOCKING ASSEMBLY W/4 NAILS OF A SUITABLE SIZE (10d FOR 2" THICK MATERIAL). NAIL EACH ADDITIONAL PIECE TO THE PREVIOUS PIECE IN A SIMILAR MANNER. NOTE: MULTIPLE PIECES MAY BE LAMINATED TOGETHER FIRST AND THEN TOENAILED TO THE REAR BLOCKING ASSEMBLY. SEE SPECIAL NOTE 2 ON PAGE 5 AND "DETAIL A" AND "DETAIL B" ON PAGE 25.
- ② FORWARD/REAR BLOCKING ASSEMBLY (2 REQD, TYPE "A"). SEE THE DETAIL ON PAGE 22, THE ALTERNATIVE FORWARD/REAR BLOCKING ASSEMBLY ON PAGE 19, AND SPECIAL NOTE 2 ON PAGE 7.
- ③ SIDE FILL ASSEMBLY A (4 REQD). SEE THE DETAIL AND SPECIAL NOTE 3 ON PAGE 7.
- ④ SEPARATOR GATE A (10 REQD, TYPE "G"). SEE THE DETAIL ON PAGE 23 AND SPECIAL NOTE 3 ON PAGE 5.
- ⑤ LOAD BEARING GATE A (2 REQD, TYPE "M"). SEE THE DETAIL ON PAGE 23.

SEE SPECIAL NOTE 5 ON PAGE 7.

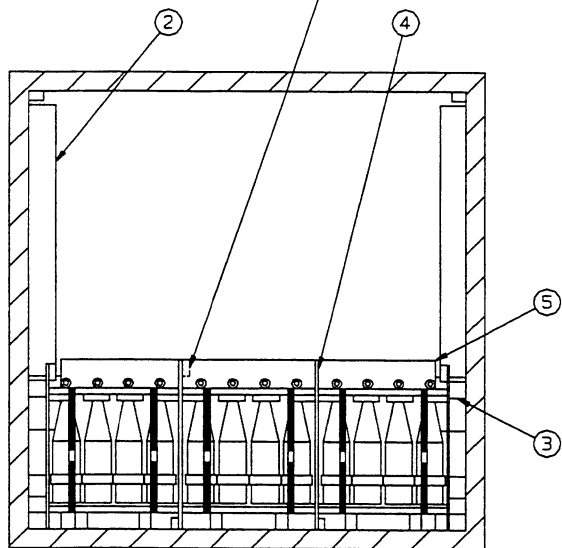

SECTION A-A

RECOMMENDED SEQUENTIAL LOADING PROCEDURES

1. PREFABRICATE TWO FORWARD/REAR BLOCKING ASSEMBLIES (TYPE "A"), NAIL FILL MATERIAL TO EACH BUFFER PIECE ON THE FORWARD BLOCKING ASSEMBLY, AND FABRICATE FOUR SIDE FILL ASSEMBLIES "A", 10 SEPARATOR GATES "A" (TYPE "G"), AND TWO LOAD BEARING GATES "A" (TYPE "M").
2. INSTALL THE FORWARD BLOCKING ASSEMBLY.
3. INSTALL TWO SIDE FILL ASSEMBLIES.
4. LOAD 18 PALLET UNITS AND INSTALL FOUR SEPARATOR GATES.
5. INSTALL ONE LOAD BEARING GATE AGAINST ALREADY LOADED PALLET UNITS.
6. REPEAT STEPS 3 THRU 5.
7. LOAD NINE PALLET UNITS AND INSTALL TWO SEPARATOR GATES.
8. INSTALL THE REAR BLOCKING ASSEMBLY.
9. INSTALL THE FILL MATERIAL BETWEEN THE REAR BLOCKING ASSEMBLY AND THE LOAD RETAINERS.

SPECIAL NOTES:

1. THE LOAD AS DEPICTED ON PAGE 6 IS FOR SMALL WOODEN PALLET UNITS OF 155MM SEPARATE LOADING PROJECTILES.
2. AT LEAST TWO PIECES OF FILL MATERIAL WILL BE LAMINATED TO BOTH BUFFER PIECES ON THE FORWARD BLOCKING ASSEMBLY BEFORE THE ASSEMBLY IS INSTALLED INTO THE CONTAINER. NAIL AS SPECIFIED IN KEY NUMBER ① ON PAGE 6.
3. THE THICKNESS OF THE PLYWOOD USED ON THE SIDE FILL ASSEMBLIES AND THE SEPARATOR GATES, PIECES MARKED ③ AND ④, MUST BE VARIED AS NECESSARY TO ENSURE NO MORE THAN 1-1/2" OF VOID ACROSS THE WIDTH OF THE LOAD.
4. PALLET UNITS WHICH ARE ALREADY BUNDLED TOGETHER WITH STEEL STRAPPING INTO GROUPS OF THREE MAY REMAIN BUNDLED FOR SHIPMENT. ONLY THE BUNDLING STRAPS HAVE BEEN SHOWN IN THE LOAD ON PAGE 6, UNITIZATION STRAPS HAVE BEEN OMITTED FOR CLARITY PURPOSES. BUNDLING STRAPS HAVE BEEN SHOWN AS TYPICAL ONLY, AND ARE NOT SPECIFICALLY REQUIRED WHEN LOADING IN ACCORDANCE WITH THE PROCEDURES DETAILED ON PAGE 6.
5. WHEN LOADING PALLET UNITS WITHOUT BUNDLING STRAPS, A RETAINER PIECE MUST BE APPLIED TO ONE OF THE TWO SEPARATOR GATES IN EACH LOAD BAY. SEE THE "SECTION A-A" VIEW ON PAGE 6 AND THE "SEPARATOR GATE A" DETAIL ON PAGE 23.

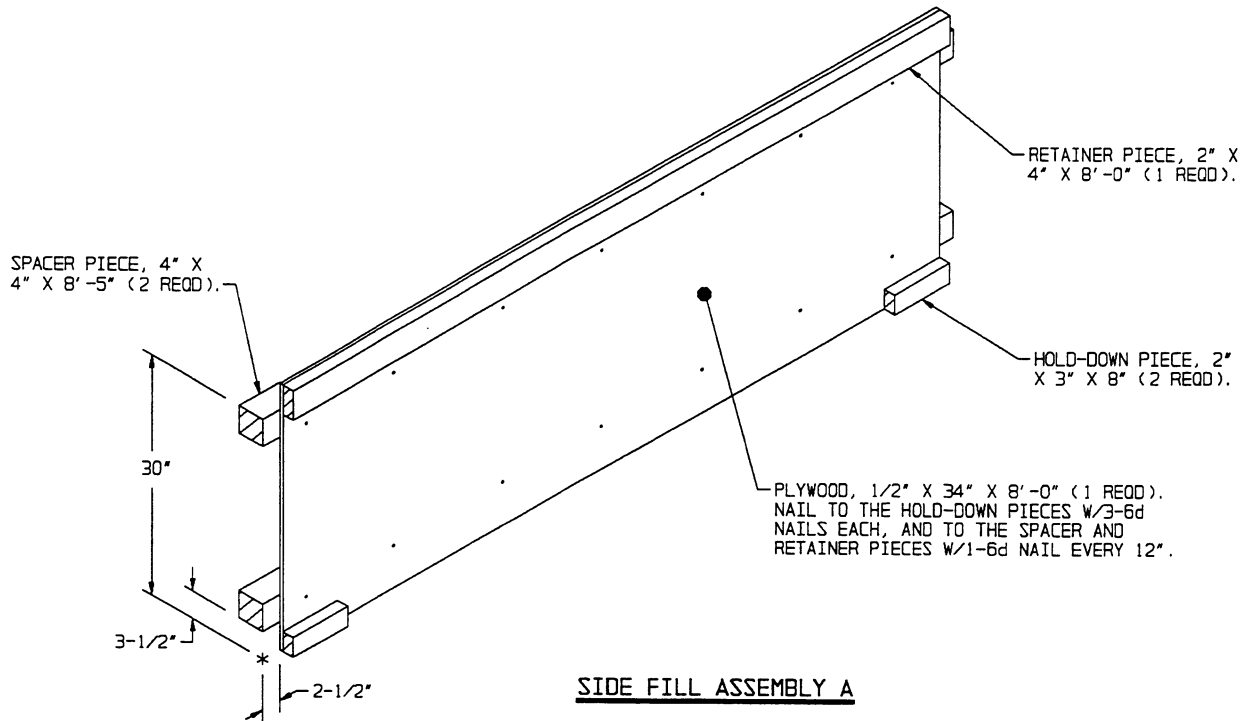

SIDE FILL ASSEMBLY A

BILL OF MATERIAL		
LUMBER	LINEAR FEET	BOARD FEET
2" X 3"	42	21
2" X 4"	74	50
2" X 6"	122	122
4" X 4"	68	91
NAILS	NO. REQD	POUNDS
6d (2")	386	2-1/2
10d (3")	104	1-3/4
PLYWOOD, 1/2" ---	129.56 SQ FT REQD	--- 178.15 LBS
PLYWOOD, 3/4" ---	133.70 SQ FT REQD	--- 275.76 LBS

LOAD AS SHOWN

ITEM	QUANTITY	WEIGHT (APPROX)
PALLET UNIT	45	36,000 LBS
DUNNAGE		1,027 LBS
CONTAINER		4,700 LBS
TOTAL WEIGHT		41,727 LBS (APPROX)

INDICATES BUNDLING STRAP. SEE SPECIAL NOTE 4 ON PAGE 9.

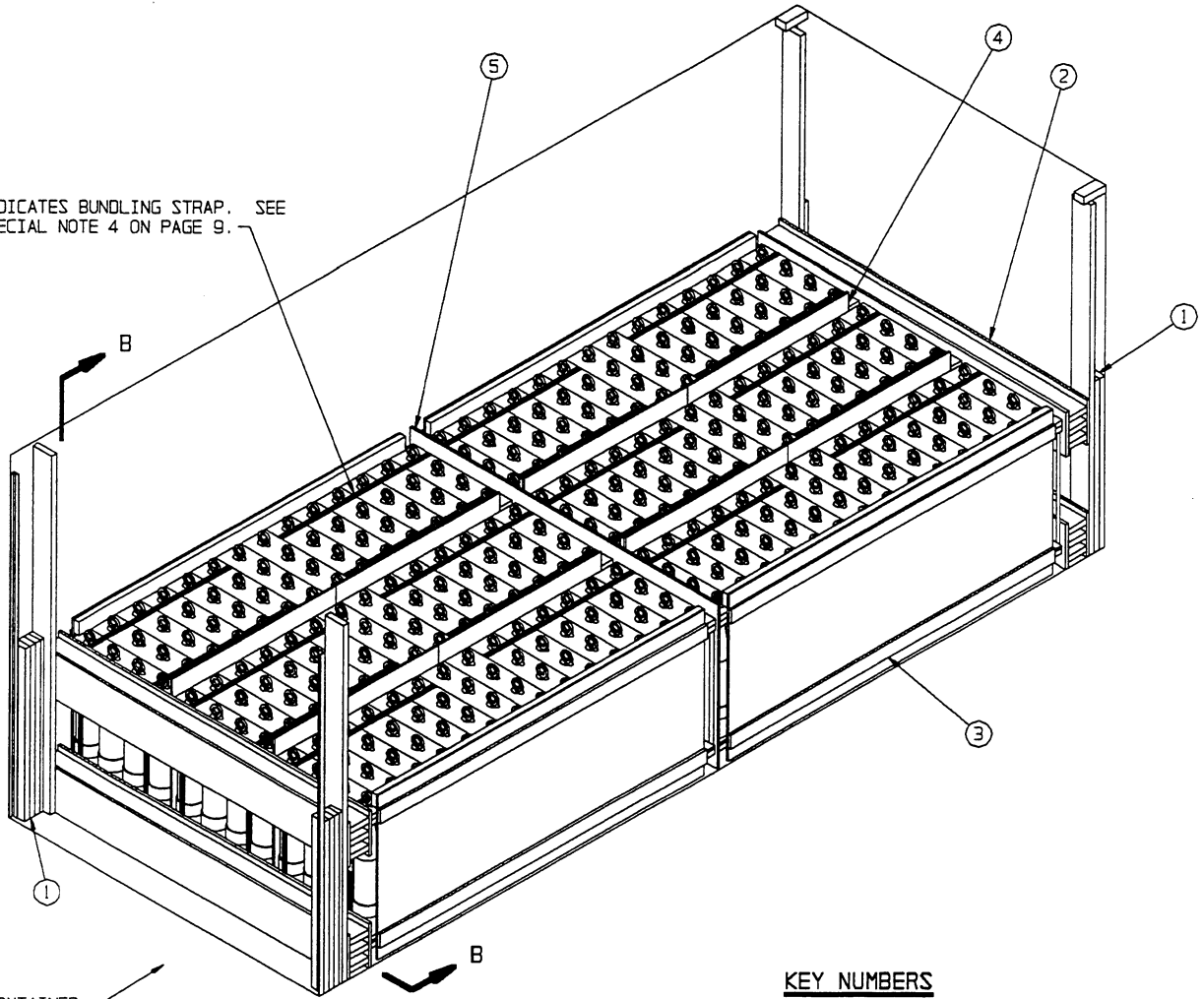

ISOMETRIC VIEW

KEY NUMBERS

- ① FILL MATERIAL, 4" WIDE BY 45" LONG MATERIAL (AS REQD). NAIL THE FIRST PIECE TO THE FORWARD/REAR BLOCKING ASSEMBLY W/5 NAILS OF A SUITABLE SIZE (10d FOR 2" THICK MATERIAL). NAIL EACH ADDITIONAL PIECE TO THE PREVIOUS PIECE IN A SIMILAR MANNER. NOTE: MULTIPLE PIECES MAY BE LAMINATED TOGETHER FIRST AND THEN TOENAILED TO THE REAR BLOCKING ASSEMBLY. SEE SPECIAL NOTE 2 ON PAGE 9 AND "DETAIL A" AND "DETAIL B" ON PAGE 25.
- ② FORWARD/REAR BLOCKING ASSEMBLY (2 REQD, TYPE "B"). SEE THE DETAIL ON PAGE 22 AND THE ALTERNATIVE FORWARD/REAR BLOCKING ASSEMBLY ON PAGE 19.
- ③ SIDE FILL ASSEMBLY B (4 REQD). SEE THE DETAIL ON PAGE 9 AND SPECIAL NOTE 3 ON PAGE 9.
- ④ SEPARATOR GATE B (8 REQD, TYPE "H"). SEE THE DETAIL ON PAGE 23 AND SPECIAL NOTES 3 AND 6 ON PAGE 9.
- ⑤ LOAD BEARING GATE A (1 REQD, TYPE "N"). SEE THE DETAIL ON PAGE 23.

SEE SPECIAL NOTE 5 ON PAGE 9.

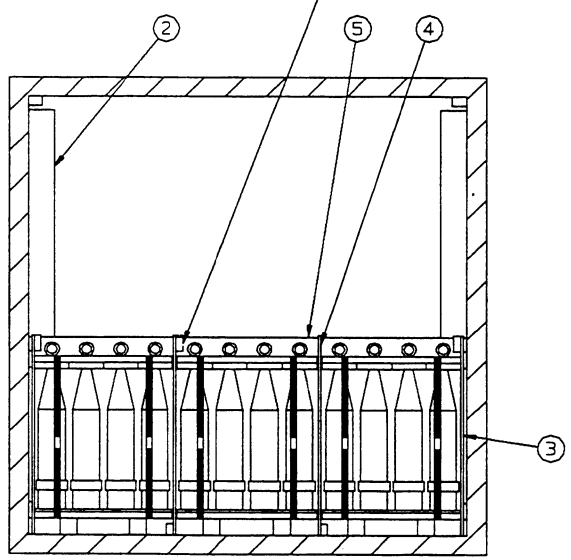

SECTION B-B

SPECIAL NOTES:

1. THE LOAD AS DEPICTED ON PAGE 8 IS FOR LARGE WOODEN PALLET UNITS OF 155MM SEPARATE LOADING PROJECTILES.
2. AT LEAST TWO PIECES OF FILL MATERIAL WILL BE LAMINATED TO BOTH BUFFER PIECES ON THE FORWARD BLOCKING ASSEMBLY BEFORE THE ASSEMBLY IS INSTALLED INTO THE CONTAINER. NAIL AS SPECIFIED IN KEY NUMBER ① ON PAGE 8.
3. THE THICKNESS OF THE PLYWOOD USED ON THE SIDE FILL ASSEMBLIES AND THE SEPARATOR GATES, PIECES MARKED ③ AND ④, MUST BE VARIED AS NECESSARY TO ENSURE NO MORE THAN 1-1/2" OF VOID ACROSS THE WIDTH OF THE LOAD.
4. PALLET UNITS WHICH ARE ALREADY BUNDLED TOGETHER WITH STEEL STRAPPING INTO GROUPS OF THREE MAY REMAIN BUNDLED FOR SHIPMENT, EXCEPT FOR THE TWO ROWS OF SINGLE PALLET UNITS REQUIRED IN THE LOAD ON PAGE 8. ONLY THE BUNDLING STRAPS HAVE BEEN SHOWN IN THE LOAD ON PAGE 8, UNITIZATION STRAPS HAVE BEEN OMITTED FOR CLARITY PURPOSES. BUNDLING STRAPS HAVE BEEN SHOWN AS TYPICAL ONLY, AND ARE NOT SPECIFICALLY REQUIRED WHEN LOADING IN ACCORDANCE WITH THE PROCEDURES DETAILED ON PAGE 8.
5. WHEN LOADING PALLET UNITS WITHOUT BUNDLING STRAPS, A RETAINER PIECE MUST BE APPLIED TO ONE OF THE TWO SEPARATOR GATES IN EACH ROW. SEE THE "SECTION B-B" VIEW ON PAGE 8 AND THE "SEPARATOR GATE B" DETAIL ON PAGE 23.
6. THE SEPARATOR GATES, PIECES MARKED ④, MAY BE REPLACED WITH ALTERNATIVE SEPARATOR GATES, IF DESIRED. THE ALTERNATIVE SEPARATOR GATES WILL BE CONSIST OF THE FOLLOWING TYPES: EIGHT SEPARATOR GATES "B" WITH DIMENSION "B" = 43-1/2", DIMENSION "C" = 42-1/2" AND DIMENSION "F" = 1/2" WILL BE LOCATED BETWEEN THE TWELVE BUNDLED GROUPS OF PALLET UNITS, AND FOUR SEPARATOR GATES "A" WITH DIMENSION "B" = 14-1/2", DIMENSION "C" = 42-1/2", DIMENSION "D" = 14-1/2", DIMENSION "E" = 0" AND DIMENSION "F" = 1/2" WILL BE LOCATED BETWEEN THE SIX SINGLE PALLET UNITS.

RECOMMENDED SEQUENTIAL LOADING PROCEDURES

1. PREFABRICATE TWO FORWARD/REAR BLOCKING ASSEMBLIES (TYPE "B"), NAIL FILL MATERIAL TO EACH BUFFER PIECE ON THE FORWARD BLOCKING ASSEMBLY, AND FABRICATE FOUR SIDE FILL ASSEMBLIES "B", EIGHT SEPARATOR GATES "B" (TYPE "H"), AND ONE LOAD BEARING GATE "A" (TYPE "N").
2. INSTALL THE FORWARD BLOCKING ASSEMBLY.
3. INSTALL TWO SIDE FILL ASSEMBLIES.
4. LOAD 21 PALLET UNITS AND INSTALL FOUR SEPARATOR GATES.
5. INSTALL ONE LOAD BEARING GATE AGAINST ALREADY LOADED PALLET UNITS.
6. REPEAT STEPS 3 THRU 5.
7. INSTALL THE REAR BLOCKING ASSEMBLY.
8. INSTALL THE FILL MATERIAL BETWEEN THE REAR BLOCKING ASSEMBLY AND THE LOAD RETAINERS.

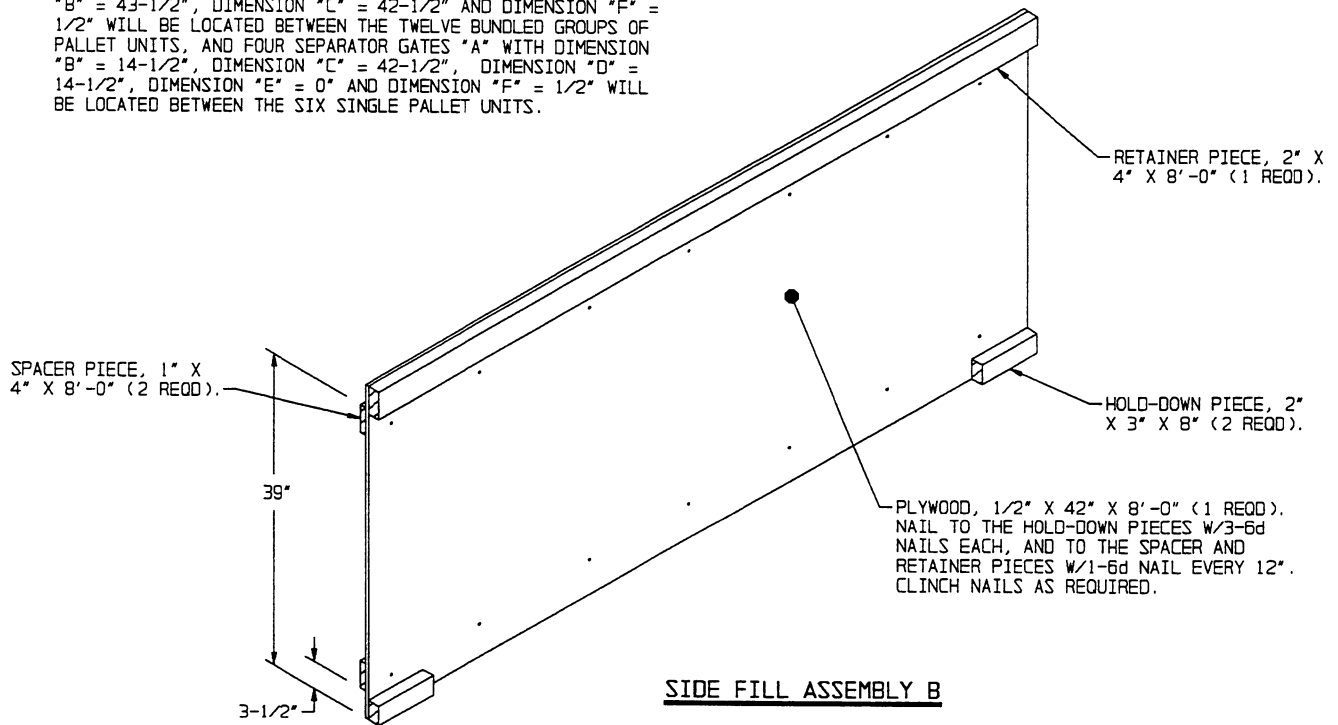

BILL OF MATERIAL		
LUMBER	LINEAR FEET	BOARD FEET
1" X 4"	72	24
2" X 3"	18	9
2" X 4"	70	47
2" X 6"	122	122
NAILS	NO. REQD	POUNDS
6d (2")	436	2-3/4
10d (3")	98	1-3/4
PLYWOOD, 1/2"	250.55 SQ FT REQD	344.51 LBS
PLYWOOD, 3/4"	58.14 SQ FT REQD	119.92 LBS

LOAD AS SHOWN

ITEM	QUANTITY	WEIGHT (APPROX)
PALLET UNIT	42	36,708 LBS
DUNNAGE		873 LBS
CONTAINER		4,700 LBS

TOTAL WEIGHT - - - - - 42,281 LBS (APPROX)

INDICATES BUNDLING STRAP. SEE SPECIAL NOTE 4 ON PAGE 11.

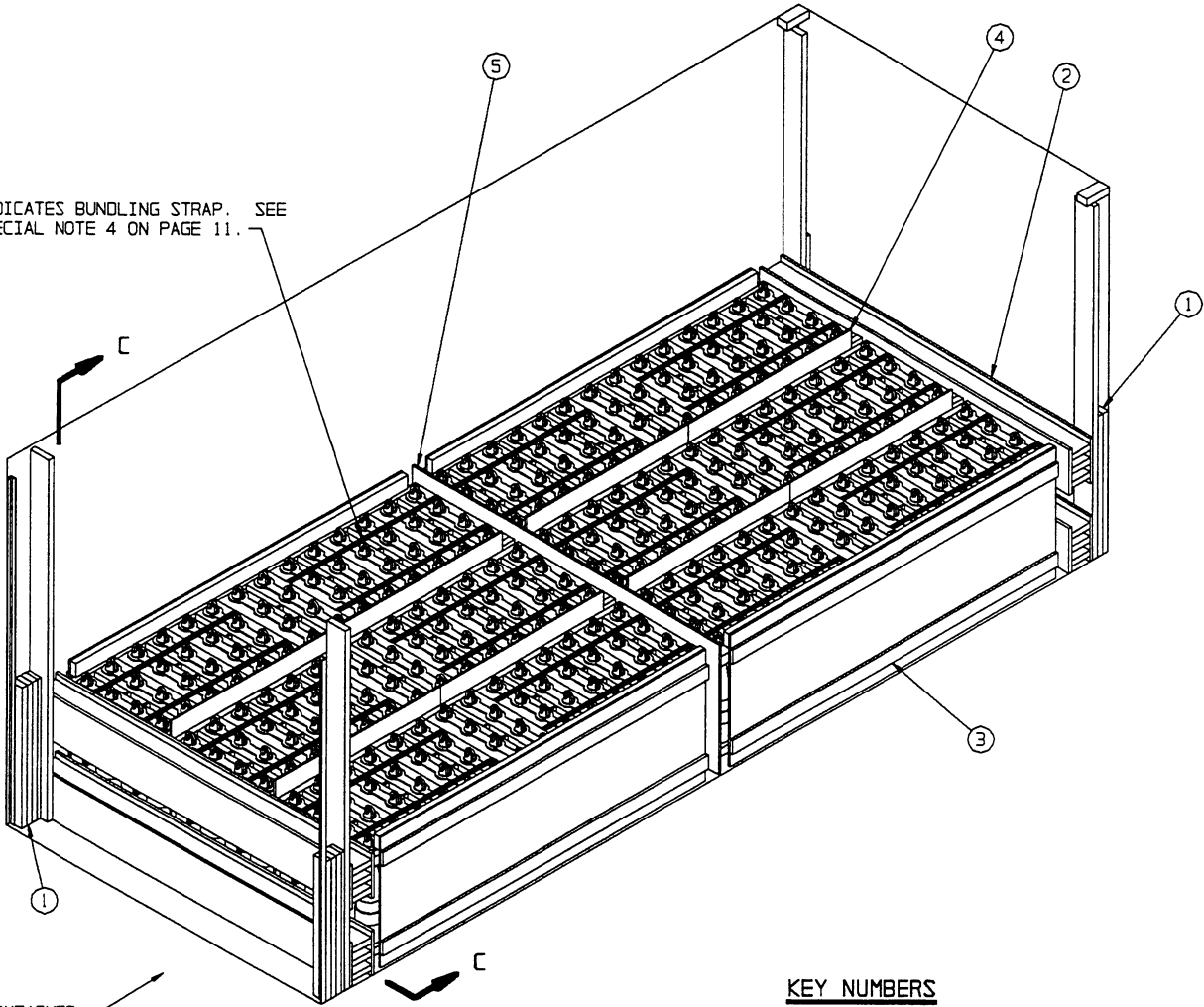

REAR OF CONTAINER.

ISOMETRIC VIEW

SEE SPECIAL NOTE 5 ON PAGE 11.

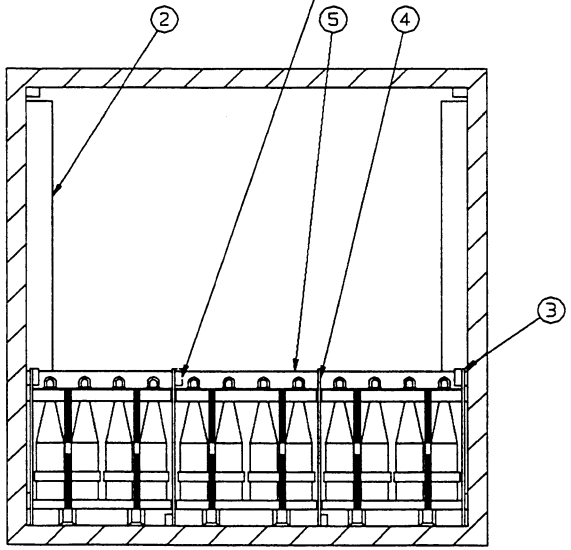

SECTION C-C

KEY NUMBERS

- ① FILL MATERIAL, 4" WIDE BY 36" LONG MATERIAL (AS REQD). NAIL THE FIRST PIECE TO THE FORWARD/REAR BLOCKING ASSEMBLY W/4 NAILS OF A SUITABLE SIZE (10d FOR 2" THICK MATERIAL). NAIL EACH ADDITIONAL PIECE TO THE PREVIOUS PIECE IN A SIMILAR MANNER. NOTE: MULTIPLE PIECES MAY BE LAMINATED TOGETHER FIRST AND THEN TOENAILED TO THE REAR BLOCKING ASSEMBLY. SEE SPECIAL NOTE 2 ON PAGE 11 AND "DETAIL A" AND "DETAIL B" ON PAGE 25.
- ② FORWARD/REAR BLOCKING ASSEMBLY (2 REQD, TYPE "C"). SEE THE DETAIL ON PAGE 22 AND THE ALTERNATIVE FORWARD/REAR BLOCKING ASSEMBLY ON PAGE 19.
- ③ SIDE FILL ASSEMBLY C (4 REQD). SEE THE DETAIL AND SPECIAL NOTE 3 ON PAGE 11.
- ④ SEPARATOR GATE B (8 REQD, TYPE "J"). SEE THE DETAIL ON PAGE 23 AND SPECIAL NOTES 3 AND 6 ON PAGE 11.
- ⑤ LOAD BEARING GATE A (1 REQD, TYPE "O"). SEE THE DETAIL ON PAGE 23.

SPECIAL NOTES:

1. THE LOAD AS DEPICTED ON PAGE 12 IS FOR METAL PALLET UNITS OF SHORT 155MM SEPARATE LOADING PROJECTILES.
2. AT LEAST TWO PIECES OF FILL MATERIAL WILL BE LAMINATED TO BOTH BUFFER PIECES ON THE FORWARD BLOCKING ASSEMBLY BEFORE THE ASSEMBLY IS INSTALLED INTO THE CONTAINER. NAIL AS SPECIFIED IN KEY NUMBER ① ON PAGE 10.
3. THE THICKNESS OF THE PLYWOOD USED ON THE SIDE FILL ASSEMBLIES AND THE SEPARATOR GATES, PIECES MARKED ③ AND ④, MUST BE VARIED AS NECESSARY TO ENSURE NO MORE THAN 1-1/2" OF VOID ACROSS THE WIDTH OF THE LOAD.
4. PALLET UNITS WHICH ARE ALREADY BUNDLED TOGETHER WITH STEEL STRAPPING INTO GROUPS OF THREE MAY REMAIN BUNDLED FOR SHIPMENT, EXCEPT FOR THE TWO ROWS OF SINGLE PALLET UNITS REQUIRED IN THE LOAD ON PAGE 10. ONLY THE BUNDLING STRAPS HAVE BEEN SHOWN IN THE LOAD ON PAGE 10, UNITIZATION STRAPS HAVE BEEN OMITTED FOR CLARITY PURPOSES. BUNDLING STRAPS HAVE BEEN SHOWN AS TYPICAL ONLY, AND ARE NOT SPECIFICALLY REQUIRED WHEN LOADING IN ACCORDANCE WITH THE PROCEDURES DETAILED ON PAGE 10.
5. WHEN LOADING THREE OR MORE CONSECUTIVE ROWS OF PALLET UNITS WITHOUT BUNDLING STRAPS, A RETAINER PIECE MUST BE APPLIED TO ONE OF THE TWO SEPARATOR GATES IN EACH ROW. SEE THE "SECTION C-C" VIEW ON PAGE 10 AND THE "SEPARATOR GATE B" DETAIL ON PAGE 23.
6. THE SEPARATOR GATES, PIECES MARKED ④, MAY BE REPLACED WITH ALTERNATIVE SEPARATOR GATES, IF DESIRED. THE ALTERNATIVE SEPARATOR GATES WILL BE CONSIST OF THE FOLLOWING TYPES: EIGHT SEPARATOR GATES "B" WITH DIMENSION "B" = 43-1/2", DIMENSION "C" = 33-1/2" AND DIMENSION "F" = 1/2" WILL BE LOCATED BETWEEN THE TWELVE BUNDLED GROUPS OF PALLET UNITS, AND FOUR SEPARATOR GATES "A" WITH DIMENSION "B" = 14-1/2", DIMENSION "C" = 33-1/2", DIMENSION "D" = 14-1/2", DIMENSION "E" = 0" AND DIMENSION "F" = 1/2" WILL BE LOCATED BETWEEN THE SIX SINGLE PALLET UNITS.

RECOMMENDED SEQUENTIAL LOADING PROCEDURES

1. PREFABRICATE TWO FORWARD/REAR BLOCKING ASSEMBLIES (TYPE "C"), NAIL FILL MATERIAL TO EACH BUFFER PIECE ON THE FORWARD BLOCKING ASSEMBLY, AND FABRICATE FOUR SIDE FILL ASSEMBLIES "C", EIGHT SEPARATOR GATES "B" (TYPE "J"), AND ONE LOAD BEARING GATE "A" (TYPE "O").
2. INSTALL THE FORWARD BLOCKING ASSEMBLY.
3. INSTALL TWO SIDE FILL ASSEMBLIES.
4. LOAD 21 PALLET UNITS AND INSTALL FOUR SEPARATOR GATES.
5. INSTALL ONE LOAD BEARING GATE AGAINST ALREADY LOADED PALLET UNITS.
6. REPEAT STEPS 3 THRU 5.
7. INSTALL THE REAR BLOCKING ASSEMBLY.
8. INSTALL THE FILL MATERIAL BETWEEN THE REAR BLOCKING ASSEMBLY AND THE LOAD RETAINERS.

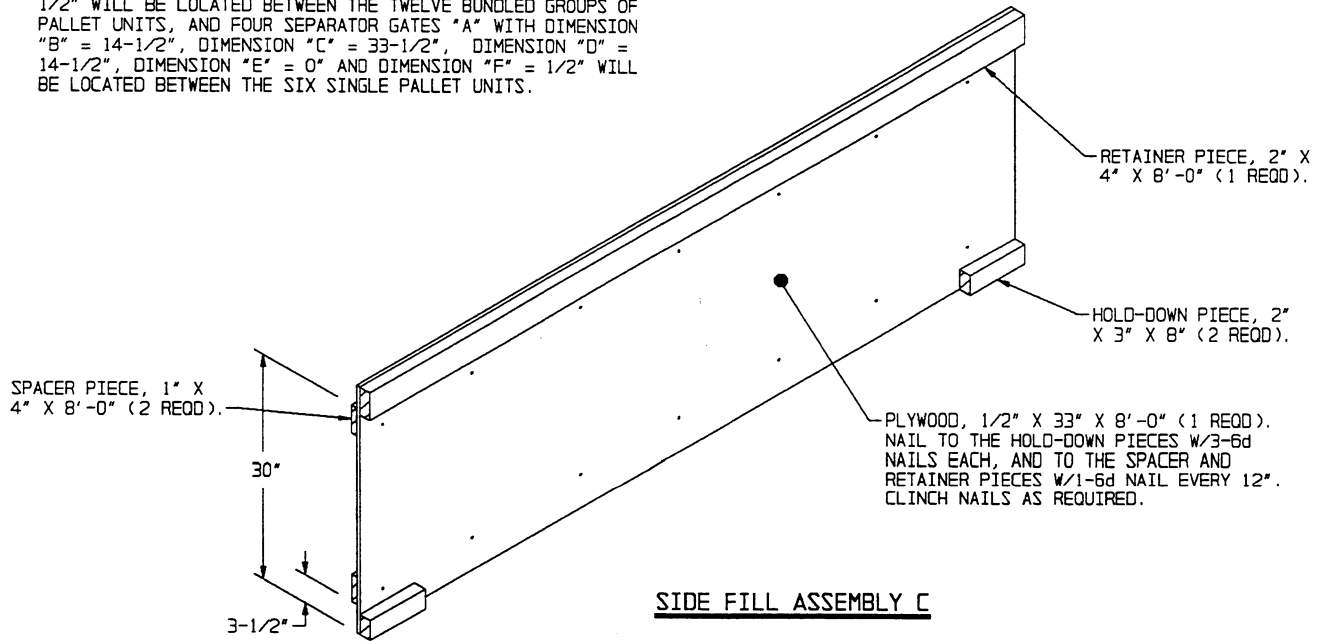

SIDE FILL ASSEMBLY C

BILL OF MATERIAL		
LUMBER	LINEAR FEET	BOARD FEET
1" X 4"	70	24
2" X 3"	18	9
2" X 4"	62	42
2" X 6"	122	122
NAILS	NO. REQD	POUNDS
6d (2")	434	2-3/4
10d (3")	88	1-1/2
PLYWOOD, 1/2" - - -	196.86 SQ FT REQD	- - - 270.69 LBS
PLYWOOD, 3/4" - - -	58.14 SQ FT REQD	- - - 119.92 LBS

LOAD AS SHOWN

ITEM	QUANTITY	WEIGHT (APPROX)
PALLET UNIT	42	35,994 LBS
DUNNAGE		789 LBS
CONTAINER		4,700 LBS

TOTAL WEIGHT - - - - - 41,483 LBS (APPROX)

INDICATES BUNDLING STRAP. SEE SPECIAL NOTE 4 ON PAGE 13.

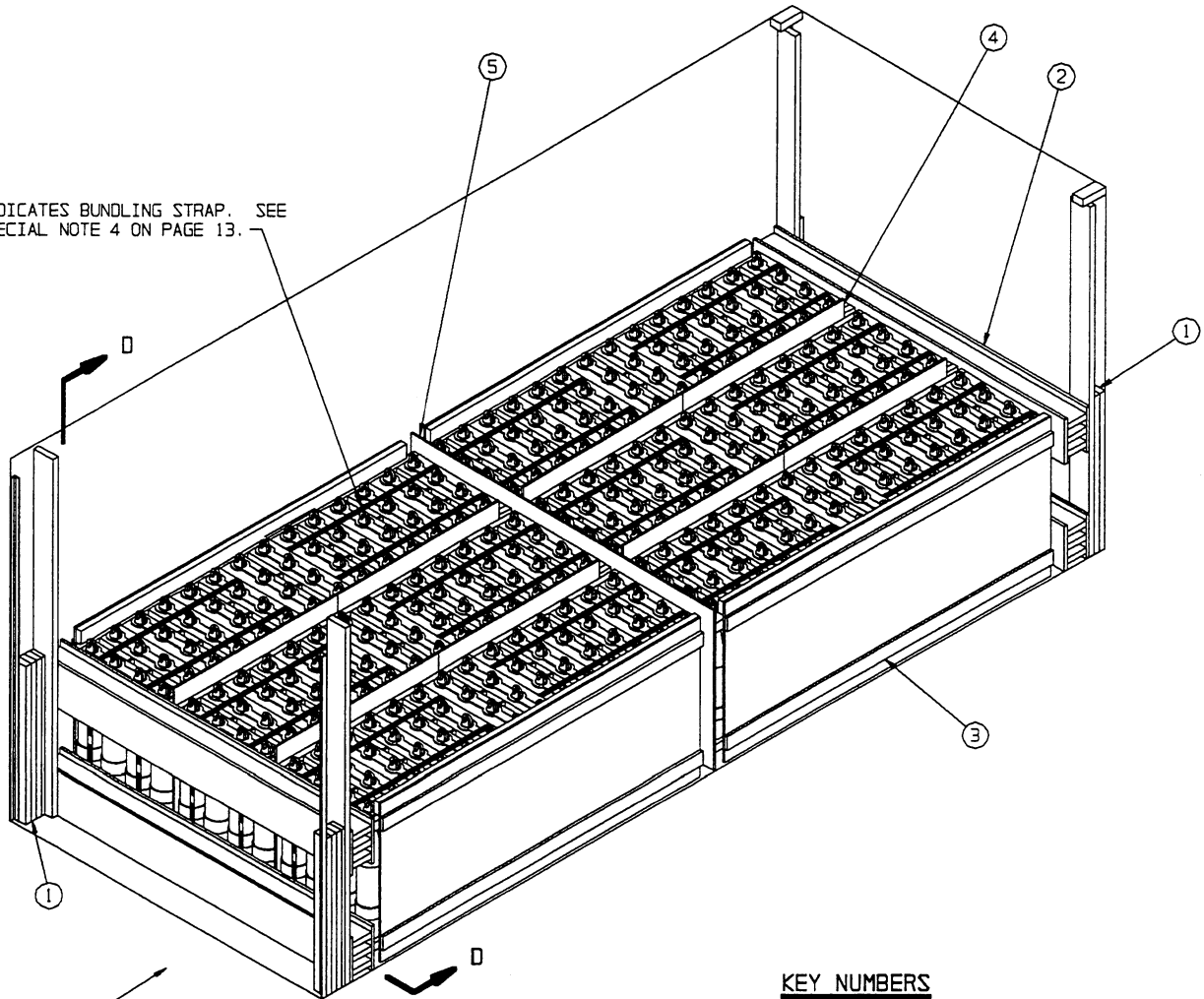

REAR OF CONTAINER.

ISOMETRIC VIEW

SEE SPECIAL NOTE 5 ON PAGE 13.

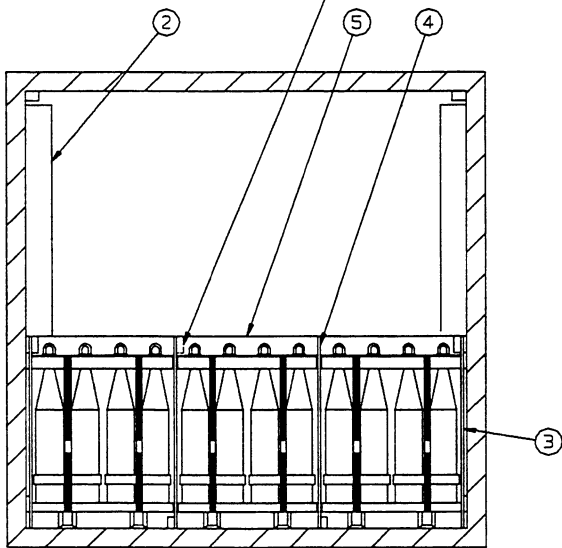

SECTION D-D

KEY NUMBERS

- ① FILL MATERIAL, 4" WIDE BY 43" LONG MATERIAL (AS REQD). NAIL THE FIRST PIECE TO THE FORWARD/REAR BLOCKING ASSEMBLY W/5 NAILS OF A SUITABLE SIZE (10d FOR 2" THICK MATERIAL). NAIL EACH ADDITIONAL PIECE TO THE PREVIOUS PIECE IN A SIMILAR MANNER. NOTE: MULTIPLE PIECES MAY BE LAMINATED TOGETHER FIRST AND THEN TO NAILED TO THE REAR BLOCKING ASSEMBLY. SEE SPECIAL NOTE 2 ON PAGE 13 AND "DETAIL A" AND "DETAIL B" ON PAGE 25.
- ② FORWARD/REAR BLOCKING ASSEMBLY (2 REQD, TYPE "D"). SEE THE DETAIL ON PAGE 22 AND THE ALTERNATIVE FORWARD/REAR BLOCKING ASSEMBLY ON PAGE 19.
- ③ SIDE FILL ASSEMBLY D (4 REQD). SEE THE DETAIL AND SPECIAL NOTE 3 ON PAGE 13.
- ④ SEPARATOR GATE B (8 REQD, TYPE "K"). SEE THE DETAIL ON PAGE 23 AND SPECIAL NOTES 3 AND 6 ON PAGE 13.
- ⑤ LOAD BEARING GATE A (1 REQD, TYPE "P"). SEE THE DETAIL ON PAGE 23.

SPECIAL NOTES:

1. THE LOAD AS DEPICTED ON PAGE 12 IS FOR METAL PALLET UNITS OF TALL 155MM SEPARATE LOADING PROJECTILES.
2. AT LEAST TWO PIECES OF FILL MATERIAL WILL BE LAMINATED TO BOTH BUFFER PIECES ON THE FORWARD BLOCKING ASSEMBLY BEFORE THE ASSEMBLY IS INSTALLED INTO THE CONTAINER. NAIL AS SPECIFIED IN KEY NUMBER ① ON PAGE 12.
3. THE THICKNESS OF THE PLYWOOD USED ON THE SIDE FILL ASSEMBLIES AND THE SEPARATOR GATES, PIECES MARKED ③ AND ④, MUST BE VARIED AS NECESSARY TO ENSURE NO MORE THAN 1-1/2" OF VOID ACROSS THE WIDTH OF THE LOAD.
4. PALLET UNITS WHICH ARE ALREADY BUNDLED TOGETHER WITH STEEL STRAPPING INTO GROUPS OF THREE MAY REMAIN BUNDLED FOR SHIPMENT, EXCEPT FOR THE TWO ROWS OF SINGLE PALLET UNITS REQUIRED IN THE LOAD ON PAGE 12. ONLY THE BUNDLING STRAPS HAVE BEEN SHOWN IN THE LOAD ON PAGE 12, UNITIZATION STRAPS HAVE BEEN OMITTED FOR CLARITY PURPOSES. BUNDLING STRAPS HAVE BEEN SHOWN AS TYPICAL ONLY, AND ARE NOT SPECIFICALLY REQUIRED WHEN LOADING IN ACCORDANCE WITH THE PROCEDURES DETAILED ON PAGE 12.
5. WHEN LOADING THREE OR MORE CONSECUTIVE ROWS OF PALLET UNITS WITHOUT BUNDLING STRAPS, A RETAINER PIECE MUST BE APPLIED TO ONE OF THE TWO SEPARATOR GATES IN EACH ROW. SEE THE "SECTION D-D" VIEW ON PAGE 12 AND THE "SEPARATOR GATE B" DETAIL ON PAGE 23.
6. THE SEPARATOR GATES, PIECES MARKED ④, MAY BE REPLACED WITH ALTERNATIVE SEPARATOR GATES, IF DESIRED. THE ALTERNATIVE SEPARATOR GATES WILL BE CONSIST OF THE FOLLOWING TYPES: EIGHT SEPARATOR GATES "B" WITH DIMENSION "B" = 43-1/2", DIMENSION "C" = 41" AND DIMENSION "F" = 1/2" WILL BE LOCATED BETWEEN THE TWELVE BUNDLED GROUPS OF PALLET UNITS, AND FOUR SEPARATOR GATES "A" WITH DIMENSION "B" = 14-1/2", DIMENSION "C" = 41", DIMENSION "D" = 14-1/2", DIMENSION "E" = 0" AND DIMENSION "F" = 1/2" WILL BE LOCATED BETWEEN THE SIX SINGLE PALLET UNITS.

RECOMMENDED SEQUENTIAL LOADING PROCEDURES

1. PREFABRICATE TWO FORWARD/REAR BLOCKING ASSEMBLIES (TYPE "D"), NAIL FILL MATERIAL TO EACH BUFFER PIECE ON THE FORWARD BLOCKING ASSEMBLY, AND FABRICATE FOUR SIDE FILL ASSEMBLIES "D", EIGHT SEPARATOR GATES "B" (TYPE "K"), AND ONE LOAD BEARING GATE "A" (TYPE "P").
2. INSTALL THE FORWARD BLOCKING ASSEMBLY.
3. INSTALL TWO SIDE FILL ASSEMBLIES.
4. LOAD 21 PALLET UNITS AND INSTALL FOUR SEPARATOR GATES.
5. INSTALL ONE LOAD BEARING GATE AGAINST ALREADY LOADED PALLET UNITS.
6. REPEAT STEPS 3 THRU 5.
7. INSTALL THE REAR BLOCKING ASSEMBLY.
8. INSTALL THE FILL MATERIAL BETWEEN THE REAR BLOCKING ASSEMBLY AND THE LOAD RETAINERS.

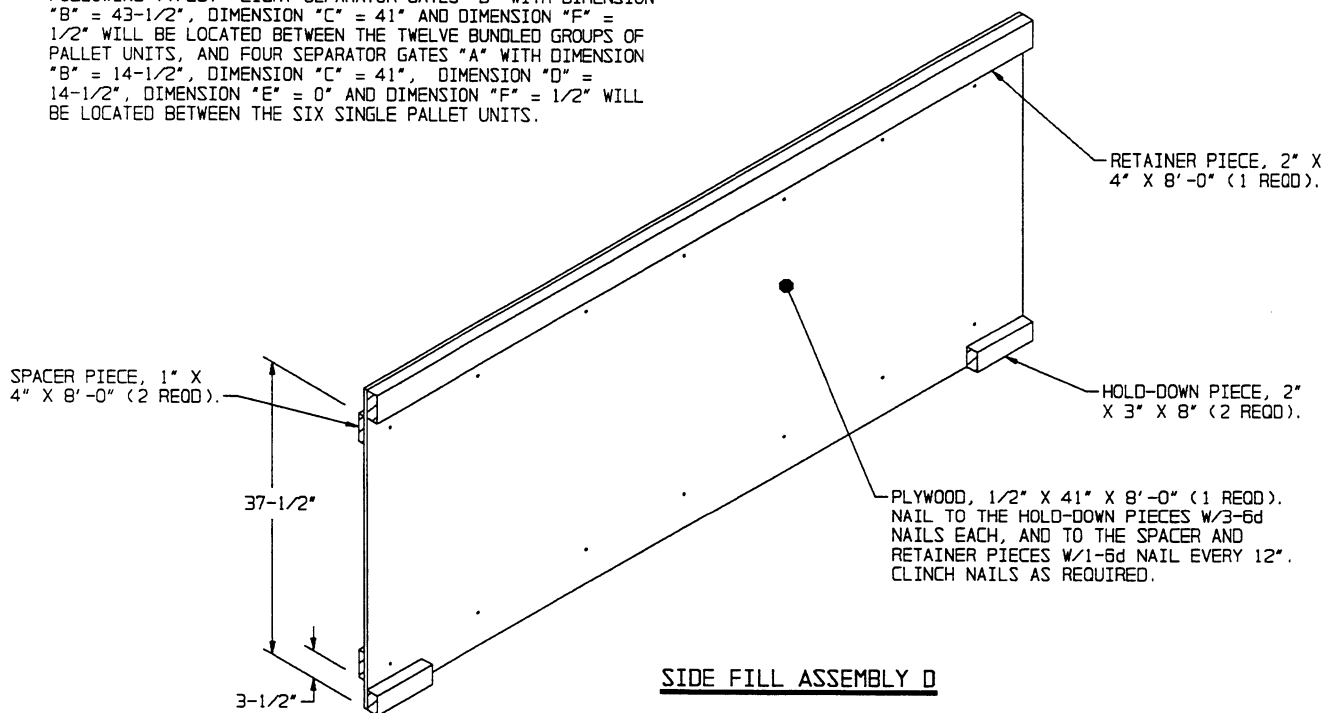

SIDE FILL ASSEMBLY D

BILL OF MATERIAL		
LUMBER	LINEAR FEET	BOARD FEET
1" X 4"	72	24
2" X 3"	18	9
2" X 4"	68	46
2" X 6"	122	122
NAILS	NO. REQD	POUNDS
6d (2")	436	2-3/4
10d (3")	98	1-3/4
PLYWOOD, 1/2" - - - -	244.57 SQ FT REQD	- - 336.28 LBS
PLYWOOD, 3/4" - - - -	58.14 SQ FT REQD	- - 119.92 LBS

LOAD AS SHOWN

ITEM	QUANTITY	WEIGHT (APPROX)
PALLET UNIT	42	37,674 LBS
DUNNAGE		863 LBS
CONTAINER		4,700 LBS
TOTAL WEIGHT		43,237 LBS (APPROX)

INDICATES BUNDLING STRAP. SEE SPECIAL NOTE 3 ON PAGE 15.

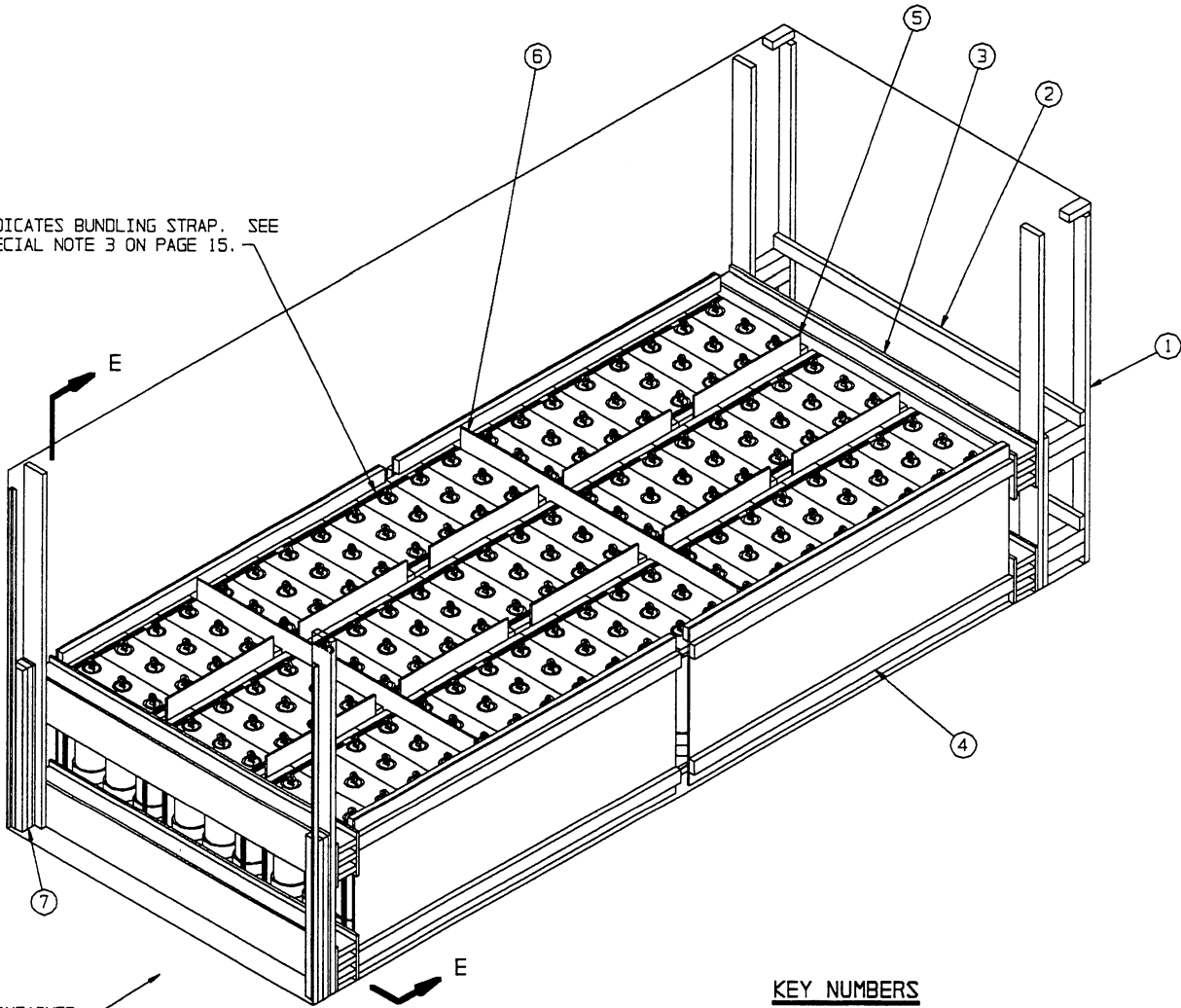

REAR OF CONTAINER.

ISOMETRIC VIEW

SEE SPECIAL NOTE 4 ON PAGE 15.

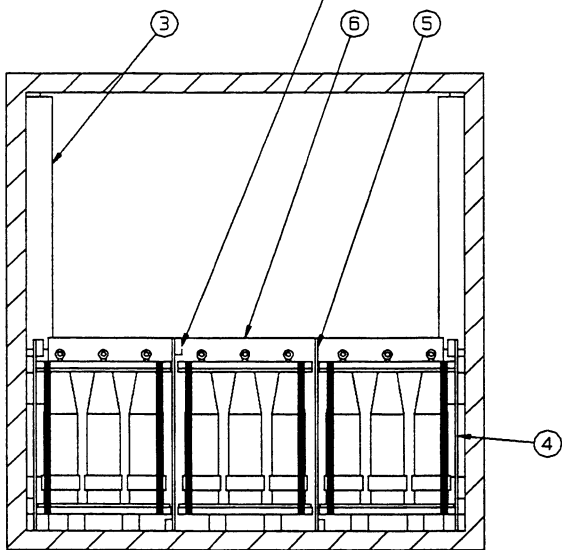

SECTION E-E

KEY NUMBERS

- ① FORWARD STRUT ASSEMBLY (2 REQD, W/11" STRUT LENGTH). SEE THE DETAIL ON PAGE 24.
- ② SPREADER PIECE, 2" X 4" BY INSIDE CONTAINER WIDTH MINUS 1" (REF: 7'-7") (2 REQD). NAIL TO THE BUFFER PIECES OF PIECE MARKED ① W/2-10d NAILS AT EACH END.
- ③ FORWARD/REAR BLOCKING ASSEMBLY (2 REQD, TYPE "E"). SEE THE DETAIL ON PAGE 22 AND THE ALTERNATIVE FORWARD/REAR BLOCKING ASSEMBLY ON PAGE 19. NAIL THROUGH THE BUFFER PIECES INTO THE VERTICAL PIECES OF PIECE MARKED ① W/6-10d NAILS.
- ④ SIDE FILL ASSEMBLY E (4 REQD). SEE THE DETAIL AND SPECIAL NOTE 2 ON PAGE 15.
- ⑤ SEPARATOR GATE A (10 REQD, TYPE "L"). SEE THE DETAIL ON PAGE 23 AND SPECIAL NOTE 2 ON PAGE 15.
- ⑥ LOAD BEARING GATE A (2 REQD, TYPE "O"). SEE THE DETAIL ON PAGE 23.
- ⑦ FILL MATERIAL, 4" WIDE BY 43" LONG MATERIAL (AS REQD). NAIL THE FIRST PIECE TO THE REAR BLOCKING ASSEMBLY W/S NAILS OF A SUITABLE SIZE (10d FOR 2" THICK MATERIAL). NAIL EACH ADDITIONAL PIECE TO THE PREVIOUS PIECE IN A SIMILAR MANNER. NOTE: MULTIPLE PIECES MAY BE LAMINATED TOGETHER FIRST AND THEN TOENAILED TO THE REAR BLOCKING ASSEMBLY. SEE "DETAIL A" AND "DETAIL B" ON PAGE 25.

RECOMMENDED SEQUENTIAL LOADING PROCEDURES

1. PREFABRICATE TWO FORWARD STRUT ASSEMBLIES W/11" STRUTS, TWO FORWARD/ REAR BLOCKING ASSEMBLIES (TYPE "E"), FOUR SIDE FILL ASSEMBLIES "E", 10 SEPARATOR GATES "A" (TYPE "L"), AND TWO LOAD BEARING GATES "A" (TYPE "O").
2. INSTALL THE TWO FORWARD STRUT ASSEMBLIES AND THE TWO SPREADER PIECES.
3. INSTALL THE FORWARD BLOCKING ASSEMBLY.
4. INSTALL TWO SIDE FILL ASSEMBLIES.
5. LOAD 12 PALLET UNITS AND INSTALL FOUR SEPARATOR GATES.
6. INSTALL ONE LOAD BEARING GATE AGAINST ALREADY LOADED PALLET UNITS.
7. REPEAT STEPS 4 THRU 6.
8. LOAD SIX PALLET UNITS AND INSTALL TWO SEPARATOR GATES.
9. INSTALL THE REAR BLOCKING ASSEMBLY.
10. INSTALL THE FILL MATERIAL BETWEEN THE REAR BLOCKING ASSEMBLY AND THE LOAD RETAINERS.

SPECIAL NOTES:

1. THE LOAD AS DEPICTED ON PAGE 14 IS FOR PALLET UNITS OF SHORT 8" SEPARATE LOADING PROJECTILES.
2. THE THICKNESS OF THE PLYWOOD USED ON THE SIDE FILL ASSEMBLIES AND THE SEPARATOR GATES, PIECES MARKED ④ AND ⑤, MUST BE VARIED AS NECESSARY TO ENSURE NO MORE THAN 1-1/2" OF VOID ACROSS THE WIDTH OF THE LOAD.
3. PALLET UNITS WHICH ARE ALREADY BUNDLED TOGETHER WITH STEEL STRAPPING INTO GROUPS OF TWO MAY REMAIN BUNDLED FOR SHIPMENT. ONLY THE BUNDLING STRAPS HAVE BEEN SHOWN IN THE LOAD ON PAGE 14, UNITIZATION STRAPS HAVE BEEN OMITTED FOR CLARITY PURPOSES. BUNDLING STRAPS HAVE BEEN SHOWN AS TYPICAL ONLY, AND ARE NOT SPECIFICALLY REQUIRED WHEN LOADING IN ACCORDANCE WITH THE PROCEDURES DETAILED ON PAGE 14.
4. WHEN LOADING TWO OR MORE CONSECUTIVE ROWS OF PALLET UNITS WITHOUT BUNDLING STRAPS, A RETAINER PIECE MUST BE APPLIED TO ONE OF THE TWO SEPARATOR GATES IN EACH ROW. SEE THE "SECTION E-E" VIEW ON PAGE 14 AND THE "SEPARATOR GATE A" DETAIL ON PAGE 23.

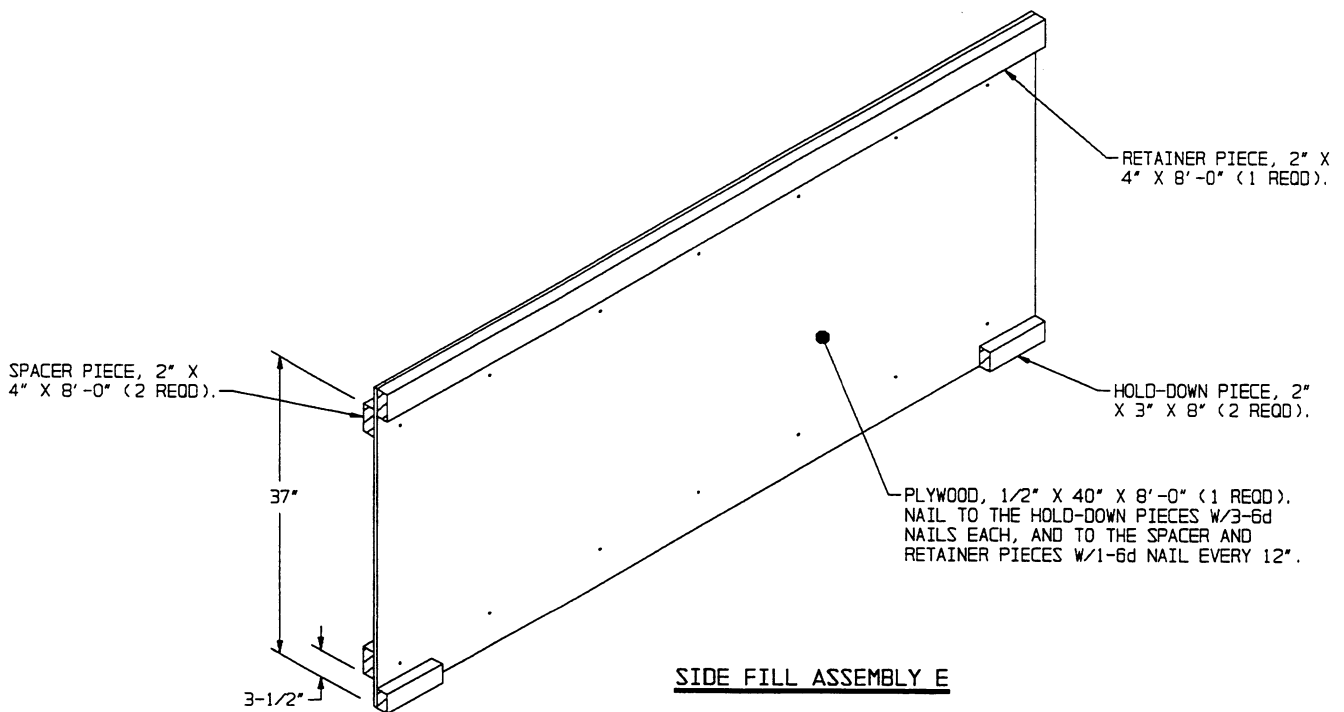

SIDE FILL ASSEMBLY E

BILL OF MATERIAL		
LUMBER	LINEAR FEET	BOARD FEET
1" X 4"	8	3
2" X 3"	41	21
2" X 4"	147	98
2" X 6"	122	122
4" X 4"	8	11
NAILS	NO. REOD	POUNDS
6d (2")	424	2-1/2
10d (3")	86	1-1/2
12d (3-1/4")	32	3/4
PLYWOOD, 1/2"	242.23 SQ FT REOD	333.07 LBS
PLYWOOD, 3/4"	58.14 SQ FT REOD	119.92 LBS

LOAD AS SHOWN

ITEM	QUANTITY	WEIGHT (APPROX)
PALLET UNIT	30	37,680 LBS
DUNNAGE		968 LBS
CONTAINER		4,700 LBS

TOTAL WEIGHT - - - - - 43,348 LBS (APPROX)

INDICATES BUNDLING STRAP, SEE SPECIAL NOTE 3 ON PAGE 17.

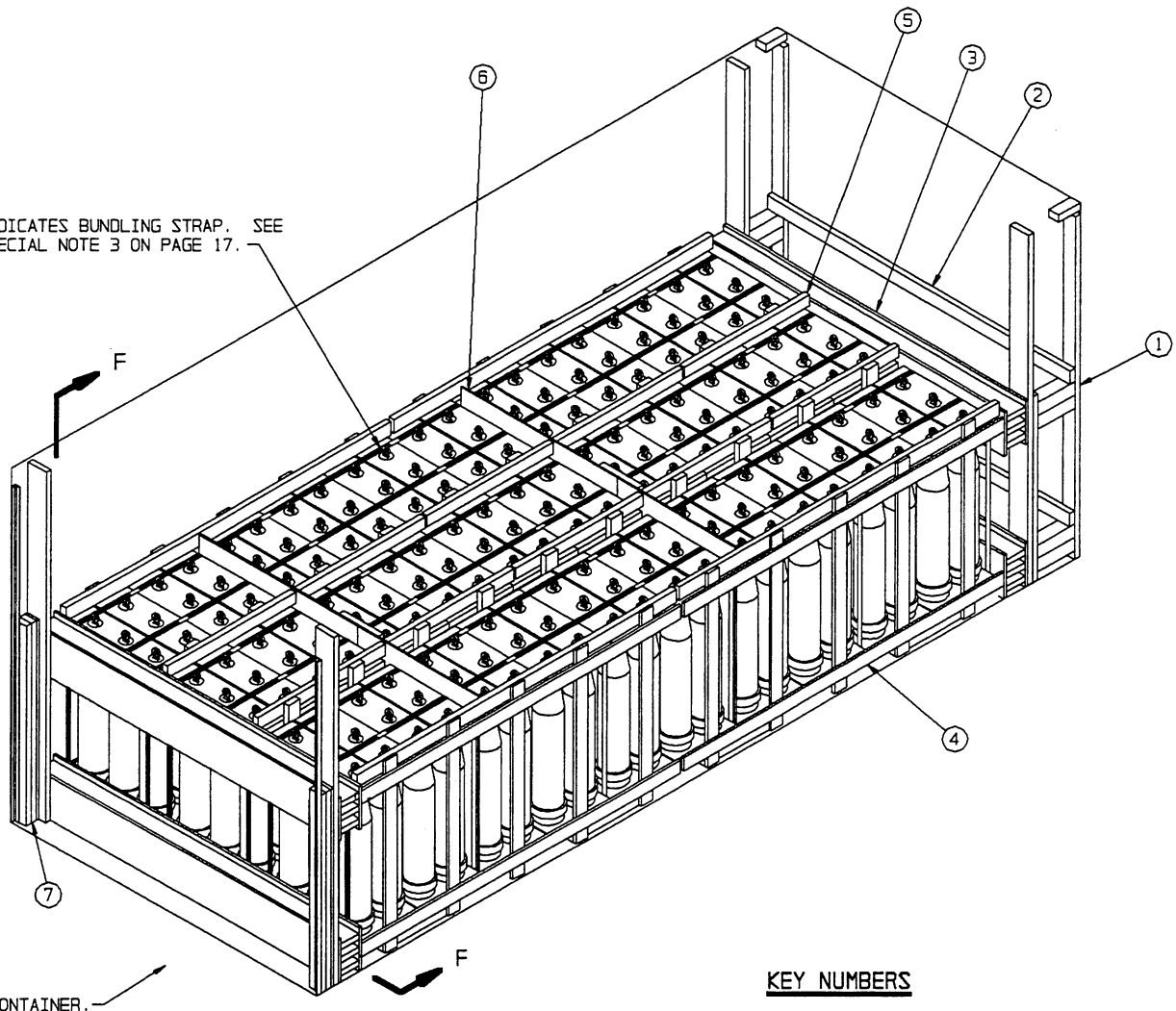

REAR OF CONTAINER.

ISOMETRIC VIEW

KEY NUMBERS

- ① FORWARD STRUT ASSEMBLY (2 REOD, W/11" STRUT LENGTH). SEE THE DETAIL ON PAGE 24.
- ② SPREADER PIECE, 2" X 4" BY INSIDE CONTAINER WIDTH MINUS 1" (REF: 7'-7") (2 REOD). NAIL TO THE BUFFER PIECES OF PIECE MARKED ① W/2-10d NAILS AT EACH END.
- ③ FORWARD/REAR BLOCKING ASSEMBLY (2 REOD, TYPE "F"). SEE THE DETAIL ON PAGE 22 AND THE ALTERNATIVE FORWARD/REAR BLOCKING ASSEMBLY ON PAGE 19. NAIL THROUGH THE BUFFER PIECES INTO THE VERTICAL PIECES OF PIECE MARKED ① W/5-10d NAILS.
- ④ SIDE FILL ASSEMBLY F (4 REOD). SEE THE DETAIL ON PAGE 18 AND SPECIAL NOTE 2 ON PAGE 17.
- ⑤ SEPARATOR GATE C (10 REOD). SEE THE DETAIL ON PAGE 18 AND SPECIAL NOTE 2 ON PAGE 17.
- ⑥ LOAD BEARING GATE B (2 REOD). SEE THE DETAIL ON PAGE 19.
- ⑦ FILL MATERIAL, 4" WIDE BY 53" LONG MATERIAL (AS REOD). NAIL THE FIRST PIECE TO THE REAR BLOCKING ASSEMBLY W/5 NAILS OF A SUITABLE SIZE (10d FOR 2" THICK MATERIAL). NAIL EACH ADDITIONAL PIECE TO THE PREVIOUS PIECE IN A SIMILAR MANNER. NOTE: MULTIPLE PIECES MAY BE LAMINATED TOGETHER FIRST AND THEN TO NAILED TO THE REAR BLOCKING ASSEMBLY. SEE "DETAIL A" AND "DETAIL B" ON PAGE 25.

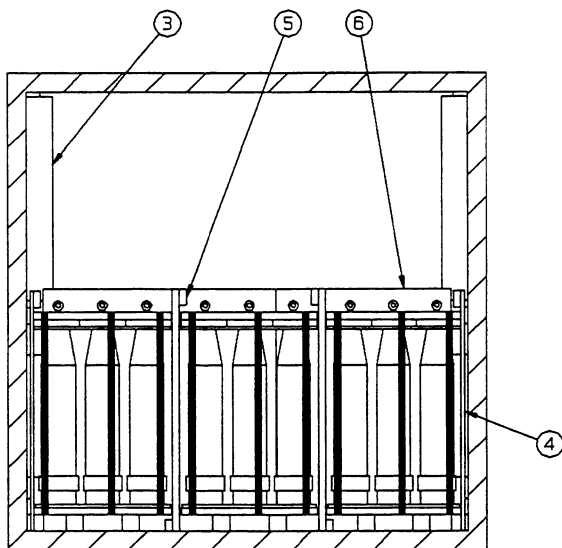

SECTION F-F

RECOMMENDED SEQUENTIAL LOADING PROCEDURES

1. PREFABRICATE TWO FORWARD STRUT ASSEMBLIES (W/11" STRUTS), TWO FORWARD/REAR BLOCKING ASSEMBLIES (TYPE "F"), FOUR SIDE FILL ASSEMBLIES "F", 10 SEPARATOR GATES "C", AND TWO LOAD BEARING GATES "B".
2. INSTALL THE TWO FORWARD STRUT ASSEMBLIES AND THE TWO SPREADER PIECES.
3. INSTALL THE FORWARD BLOCKING ASSEMBLY.
4. INSTALL TWO SIDE FILL ASSEMBLIES.
5. LOAD 12 PALLET UNITS AND INSTALL FOUR SEPARATOR GATES.
6. INSTALL ONE LOAD BEARING GATE AGAINST ALREADY LOADED PALLET UNITS.
7. REPEAT STEPS 4 THRU 6.
8. LOAD SIX PALLET UNITS AND INSTALL TWO SEPARATOR GATES.
9. INSTALL THE REAR BLOCKING ASSEMBLY.
10. INSTALL THE FILL MATERIAL BETWEEN THE REAR BLOCKING ASSEMBLY AND THE LOAD RETAINERS.

SPECIAL NOTES:

1. THE LOAD AS DEPICTED ON PAGE 16 IS FOR PALLET UNITS OF TALL 8" SEPARATE LOADING PROJECTILES.
2. THE THICKNESS OF THE VERTICAL AND SPACER PIECES USED ON THE SIDE FILL ASSEMBLIES AND THE VERTICAL PIECES USED IN THE SEPARATOR GATES, PIECES MARKED ④ AND ⑤, MUST BE VARIED AS NECESSARY TO ENSURE NO MORE THAN 1-1/2" OF VOID ACROSS THE WIDTH OF THE LOAD.
3. PALLET UNITS WHICH ARE ALREADY BUNDLED TOGETHER WITH STEEL STRAPPING INTO GROUPS OF TWO MAY REMAIN BUNDLED FOR SHIPMENT. ONLY THE BUNDLING STRAPS HAVE BEEN SHOWN IN THE LOAD ON PAGE 16. UNITIZATION STRAPS HAVE BEEN OMITTED FOR CLARITY PURPOSES. BUNDLING STRAPS HAVE BEEN SHOWN AS TYPICAL ONLY, AND ARE NOT SPECIFICALLY REQUIRED WHEN LOADING IN ACCORDANCE WITH THE PROCEDURES DETAILED ON PAGE 16.

BILL OF MATERIAL		
LUMBER	LINEAR FEET	BOARD FEET
1" X 4"	159	53
2" X 3"	51	26
2" X 4"	206	138
2" X 6"	122	122
4" X 4"	8	11
NAILS	NO. REQD	POUNDS
6d (2")	470	3
10d (3")	166	2-3/4
12d (3-1/4")	32	3/4
PLYWOOD, 1/2" - - -	60.21 SQ FT REQD - - -	82.79 LBS
PLYWOOD, 3/4" - - -	58.14 SQ FT REQD - - -	119.92 LBS

LOAD AS SHOWN

ITEM	QUANTITY	WEIGHT (APPROX)
PALLET UNIT - - - - -	30 - - - - -	38,880 LBS
DUNNAGE - - - - -	- - - - -	910 LBS
CONTAINER - - - - -	- - - - -	4,700 LBS
TOTAL WEIGHT - - - - -		44,490 LBS (APPROX)

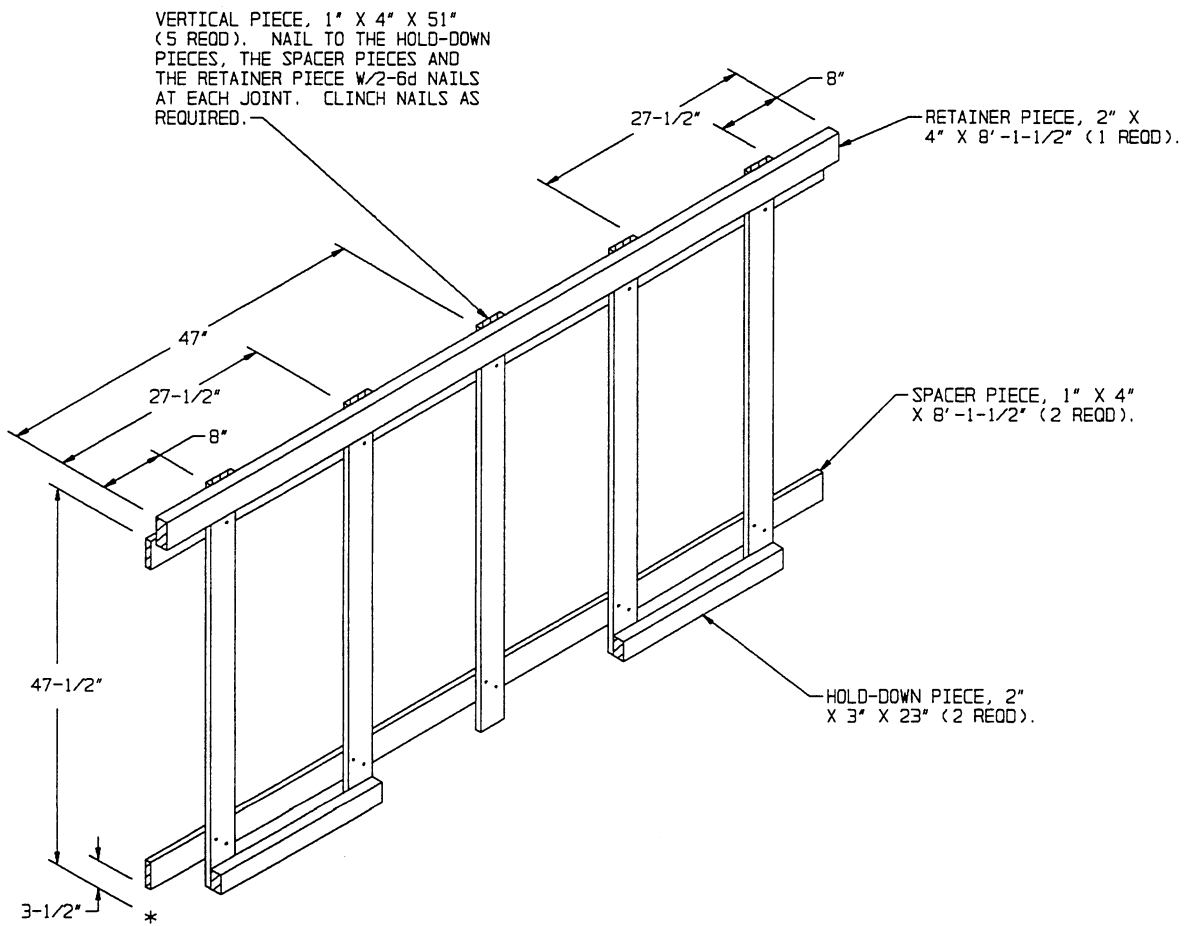

SIDE FILL ASSEMBLY F

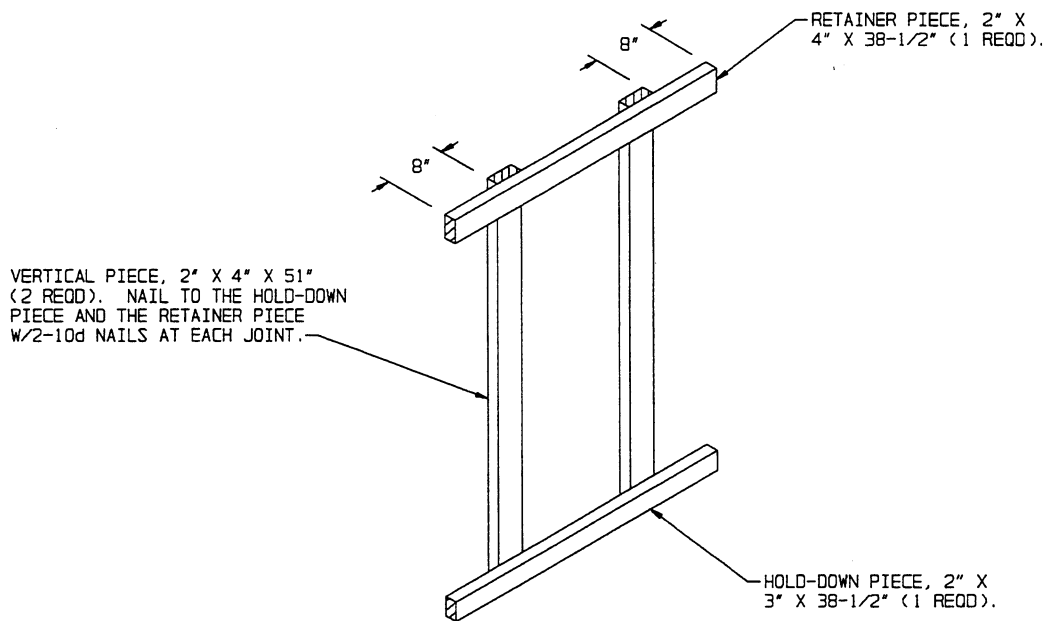

SEPARATOR GATE C

PLYWOOD, 1/2" X 48" X 51" (1 REOD). NAIL TO THE TIE PIECES AND THE HOLD-DOWN PIECE W/3-6d NAILS EACH.

TIE PIECE, 2" X 3" X 12" (2 REOD).

PLYWOOD, 1/2" X 37" X 51" (1 REOD). NAIL TO THE TIE PIECES AND THE HOLD-DOWN PIECE W/3-6d NAILS EACH.

HOLD-DOWN PIECE, 2" X 3" X 8" (2 REOD).

LOAD BEARING GATE B

BUFFER PIECE, 2" X 6" BY INSIDE CONTAINER HEIGHT MINUS 1" (REF: 7'-6" OR 7'-8") (2 REOD). NAIL TO THE BEAM ASSEMBLIES W/2-10d NAILS AT EACH JOINT.

BEAM ASSEMBLY, 2" OR 4" BY WIDTH REQUIRED BY INSIDE CONTAINER WIDTH MINUS 1" (REF: 7'-7") (TRIPLED SHOWN) (2 REOD). LAMINATE EACH PIECE TO THE PREVIOUS PIECE W/11-10d NAILS (UNLESS 4" X 4" MATERIAL IS USED).

LOAD BEARING PIECE, 2" X 6" BY HEIGHT OF THE TOP BEAM PLUS 6" (6 REOD) (DOUBLED). NAIL THE FIRST PIECE TO THE BEAM ASSEMBLIES W/3-10d NAILS AT EACH JOINT. LAMINATE THE SECOND PIECE TO THE FIRST W/4-10d NAILS.

ALTERNATIVE FORWARD/REAR BLOCKING ASSEMBLY

SIZE/WEIGHT OF BEAMS	
SIZE OF BEAM	WEIGHT PER BEAM
2" X 4"	890 LBS
2" X 6"	2,200 LBS
2" X 8"	3,850 LBS
2" X 10"	6,225 LBS
4" X 4"	2,080 LBS

SPECIAL NOTES:

1. THE ALTERNATIVE FORWARD/REAR BLOCKING ASSEMBLY MAY BE USED IN PLACE OF THE FORWARD/REAR BLOCKING ASSEMBLIES DEPICTED WITHIN THE LOADS ON PAGES 6 THRU 20, IF DESIRED.
2. BEAM ASSEMBLIES MUST BE LOCATED TO FULLY SUPPORT THE LADING UNITS. LOCATE THE UPPER BEAM ASSEMBLY AT DIMENSION "A" (FROM THE CHART ON PAGE 22) MINUS 2".
3. LOAD BEARING PIECES MUST BE LOCATED TO FULLY SUPPORT THE LADING UNITS, TWO PER LONGITUDINAL PALLET UNIT ROW.
4. THE QUANTITY AND SIZE OF BEAMS USED IN A BEAM ASSEMBLY WILL BE DETERMINED USING THE CHART AT ABOVE. FOR EXAMPLE, IF 45 LADING UNITS ARE TO BE LOADED, AND EACH UNIT WEIGHS 800 POUNDS, THE TOTAL LADING WEIGHT IS 36,000 POUNDS. TWO BEAM ASSEMBLIES ARE ALWAYS REQUIRED, SO EACH BEAM ASSEMBLY MUST BE CAPABLE OF SUPPORTING 18,000 POUNDS. THE BLOCKING ASSEMBLY MUST THEREFORE BE CONSTRUCTED USING EITHER NINE 2" X 6" BEAMS IN EACH ASSEMBLY, FIVE 2" X 8" BEAMS IN EACH ASSEMBLY, OR THREE 2" X 10" BEAMS IN EACH ASSEMBLY. IF MORE THAN FOUR BEAMS ARE USED IN AN ASSEMBLY, THE LOWER BEAM ASSEMBLY MUST BE REPOSITIONED UPWARD.
5. STRUT LEDGERS WILL BE ADDED AS DELINEATED IN THE SPECIAL NOTE ON PAGE 22.

INDICATES TYPICAL DUNNAGE ASSEMBLIES. REFER TO THE APPLICABLE LOAD PAGES FOR SPECIFIC DUNNAGE REQUIREMENTS.

INDICATES BUNDLING STRAP. SEE SPECIAL NOTE 5 ON PAGE 21.

ONE LOAD UNIT

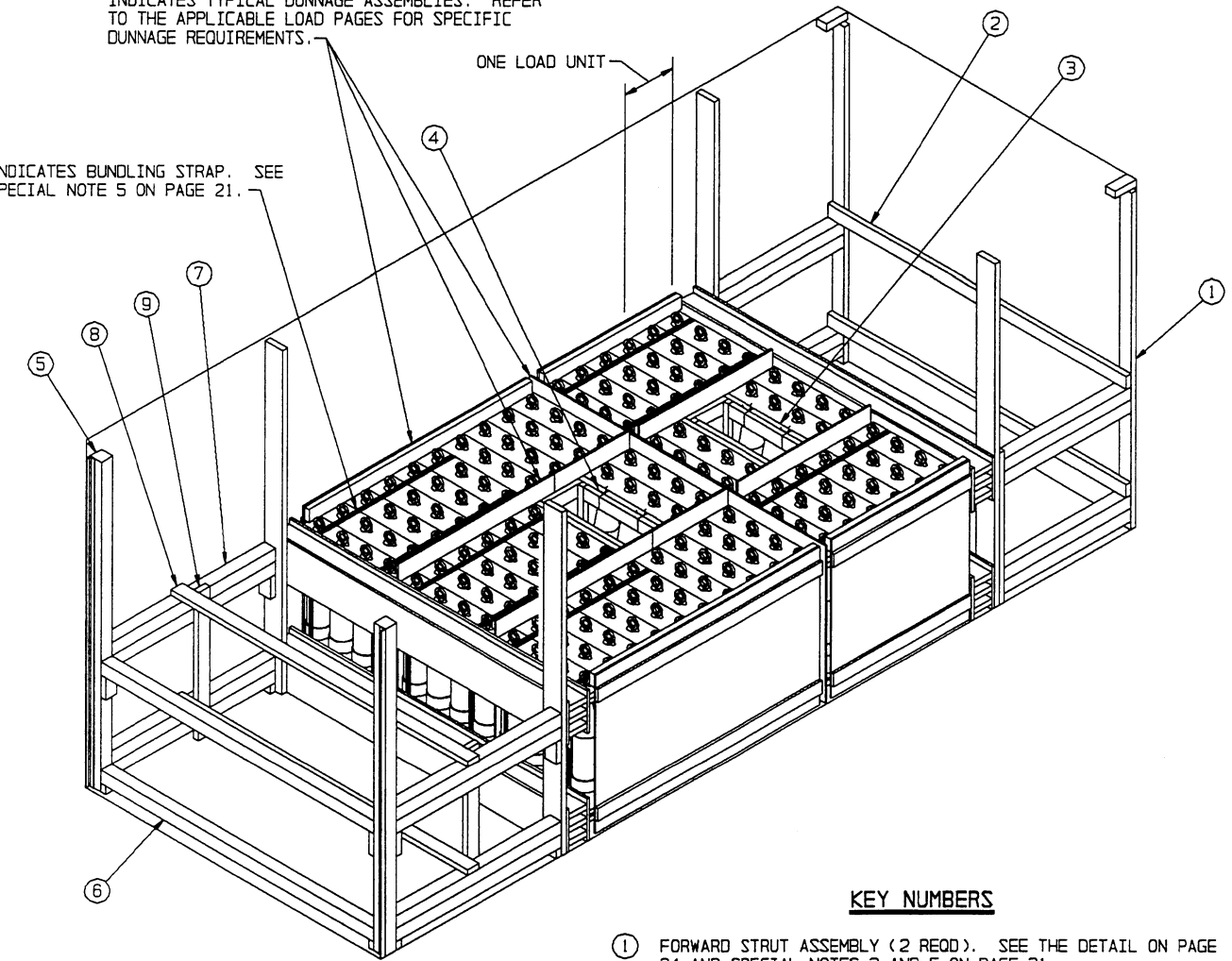

REAR OF CONTAINER.

ISOMETRIC VIEW

KEY NUMBERS

- ① FORWARD STRUT ASSEMBLY (2 REQD). SEE THE DETAIL ON PAGE 24 AND SPECIAL NOTES 2 AND 5 ON PAGE 21.
- ② SPREADER PIECE, 2" X 4" BY INSIDE CONTAINER WIDTH MINUS 1" (REF: 7'-7") (2 REQD). NAIL TO THE BUFFER PIECES OF PIECE MARKED ① W/2-10d NAILS AT EACH END.
- ③ OMITTED UNIT ASSEMBLY (AS REQD). SEE THE DETAIL AND SPECIAL NOTE 3 ON PAGE 21.
- ④ TIE WIRE, NO. 14 GAGE WIRE, 24" LONG (2 REQD PER OMITTED UNIT ASSEMBLY). INSTALL TO FORM A COMPLETE LOOP AROUND THE OMITTED UNIT ASSEMBLY AND THE PALLET UNITIZING STRAP. BRING ENDS TOGETHER AND TWIST TAUT. SECURE TO THE OMITTED UNIT ASSEMBLY WITH A PARTIALLY DRIVEN 10d NAIL BENT OVER THE WIRE OR WITH A STRAP STAPLE.
- ⑤ DOOR POST VERTICAL (2 REQD). SEE THE DETAIL ON PAGE 24, AND "DETAIL A" AND "DETAIL B" ON PAGE 25.
- ⑥ DOOR SPANNER, 4" X 4" MATERIAL, CUT TO A LENGTH THAT WILL PROVIDE FOR A DRIVE FIT (REF: 7'-1-3/8") (2 REQD). TOENAIL TO THE DOOR POST VERTICAL W/2-12d NAILS AT EACH END. SEE THE "BEVEL-CUT" DETAIL ON PAGE 3.
- ⑦ STRUT, 4" X 4" BY CUT-TO-FIT (4 REQD, DOUBLED). TOENAIL TO THE BUFFER PIECE OF THE REAR BLOCKING ASSEMBLY AND THE DOOR POST VERTICAL W/2-12d NAILS AT EACH END. SEE THE "BEVEL-CUT" DETAIL ON PAGE 3 AND SPECIAL NOTE 5 ON PAGE 21.
- ⑧ HORIZONTAL STRUT BRACING, 2" X 4" BY INSIDE CONTAINER WIDTH MINUS 1" (REF: 7'-7") (AS REQD, 2 SHOWN). NAIL TO THE STRUTS, PIECE MARKED ⑦, W/3-10d NAILS AT EACH END. SEE SPECIAL NOTE 6 ON PAGE 21.
- ⑨ VERTICAL STRUT BRACING, 2" X 4" BY A LENGTH TO EXTEND A MINIMUM OF 2" ABOVE THE TOP STRUT (AS REQD, 2 SHOWN). NAIL TO THE STRUTS, PIECE MARKED ⑦, W/2-10d NAILS AT EACH JOINT. SEE SPECIAL NOTE 6 ON PAGE 21.

(SPECIAL NOTES CONTINUED)

4. THE LENGTH OF THE DUNNAGE ASSEMBLIES USED AT THE SIDES OF THE LOADS AND BETWEEN PALLET UNITS Laterally must be modified as necessary when loading a container with a reduced quantity of pallet units. For example, the length of the two of the side fill assemblies depicted in the rear of load on page 20 have been reduced from 8'-0" to 72" to accommodate the reduction from seven to five load units within the rear load bay. When reducing the length of dunnage assemblies, care must be taken to ensure that more than one-half of each pallet unit is in contact with an adjacent dunnage assembly.
5. NOTE THAT THE QUANTITY OF STRUTS AT THE FORWARD AND REAR ENDS OF THE LOAD MAY BE REDUCED FROM EIGHT AT EACH END TO FOUR, DEPENDING ON THE TOTAL WEIGHT OF THE PALLET UNITS TO BE SHIPPED. DOUBLED STRUTS WERE SHOWN AS TYPICAL ONLY. SEE GENERAL NOTE "Q" ON PAGE 3.
6. STRUT BRACING IS ONLY REQUIRED FOR STRUTS WHICH ARE 48" OR LONGER IN LENGTH. STRUT BRACING SHOULD BE LOCATED AS NEAR AS POSSIBLE TO THE CENTER OF THE STRUTS, BUT SHOULD NOT BE LOCATED SUCH THAT ANY UNBRACED SPAN OF STRUT LENGTH EXCEEDS 48".
7. PALLET UNITS WHICH ARE ALREADY BUNDLED TOGETHER WITH STEEL STRAPPING INTO GROUPS OF TWO OR THREE MAY REMAIN BUNDLED FOR SHIPMENT, IF IT IS FEASIBLE FOR THE LOAD QUANTITY TO BE SHIPPED. ONLY THE BUNDLING STRAPS HAVE BEEN SHOWN IN THE LOAD ON PAGE 20, UNITIZATION STRAPS HAVE BEEN OMITTED FOR CLARITY PURPOSES. BUNDLING STRAPS HAVE BEEN SHOWN AS TYPICAL ONLY, AND ARE NOT SPECIFICALLY REQUIRED WHEN LOADING IN ACCORDANCE WITH THE PROCEDURES DETAILED ON PAGE 20.

SPECIAL NOTES:

1. THE LOAD AS SHOWN ON PAGE 20 DEPICTS LARGE WOODEN PALLET UNITS OF 155MM SEPARATE LOADING PROJECTILES. THIS LOAD IS SHOWN AS TYPICAL ONLY. THE PROCEDURES MAY BE ADAPTED TO LOAD REDUCED QUANTITIES OF ANY OF THE PALLET UNITS SHOWN ON PAGES 4 OR 5.
2. THE CENTER OF GRAVITY OF THE REDUCED LOAD MUST BE WITHIN 12" OF THE CENTER OF THE CONTAINER. ROUGHLY, THIS MEANS THAT THE DIFFERENCE BETWEEN THE VOID AT THE FRONT OF THE LOAD (FORWARD STRUT ASSEMBLY) AND THE VOID AT THE REAR OF THE LOAD (REAR STRUTS PLUS DOOR POST VERTICAL PLUS LOAD RETAINER) MUST NOT EXCEED 24". FOR EXAMPLE, THE FORWARD STRUT ASSEMBLY SHOWN IN THE TYPICAL LOAD ON PAGE 20 ARE 42" LONG, AND THE REAR STRUTS PLUS THE DOOR POST VERTICAL PLUS THE LOAD RETAINER ARE 55-1/2" LONG (50-3/4" PLUS 3-1/2" PLUS 1-1/4") THEREFORE THE LOAD IS BALANCED, SINCE THE DIFFERENCE IS LESS THAN 24" (13-1/2"). NOTE THAT IN THE IDEAL LOAD, THE VOID AT THE REAR OF THE LOAD WOULD BE EQUAL TO THE VOID AT THE FORWARD END OF THE LOAD. AN OFFSET LOAD WAS SHOWN ON PAGE 20 TO DISPLAY THE USE OF STRUT BRACING. THE LENGTHS OF THE STRUTS IN THE FORWARD BLOCKING ASSEMBLY AND AT THE REAR OF THE LOAD MUST BE VARIED AS NECESSARY TO ACHIEVE A BALANCED LOAD.
3. NO MORE THAN TWO OMITTED UNIT ASSEMBLIES WILL BE USED IN ANY REDUCED LOAD. OMITTED UNIT ASSEMBLIES MUST BE PLACED WITHIN THE MIDDLE ROW OF A LOAD. IF MORE THAN TWO PALLET UNITS ARE TO BE OMITTED, OMIT ONE OR MORE LOAD UNITS, AND SHIFT THE LOAD TOWARDS THE FORWARD OR REAR OF THE CONTAINER, AS REQUIRED IN SPECIAL NOTE 2 ABOVE.

(SPECIAL NOTES CONTINUED AT LEFT)

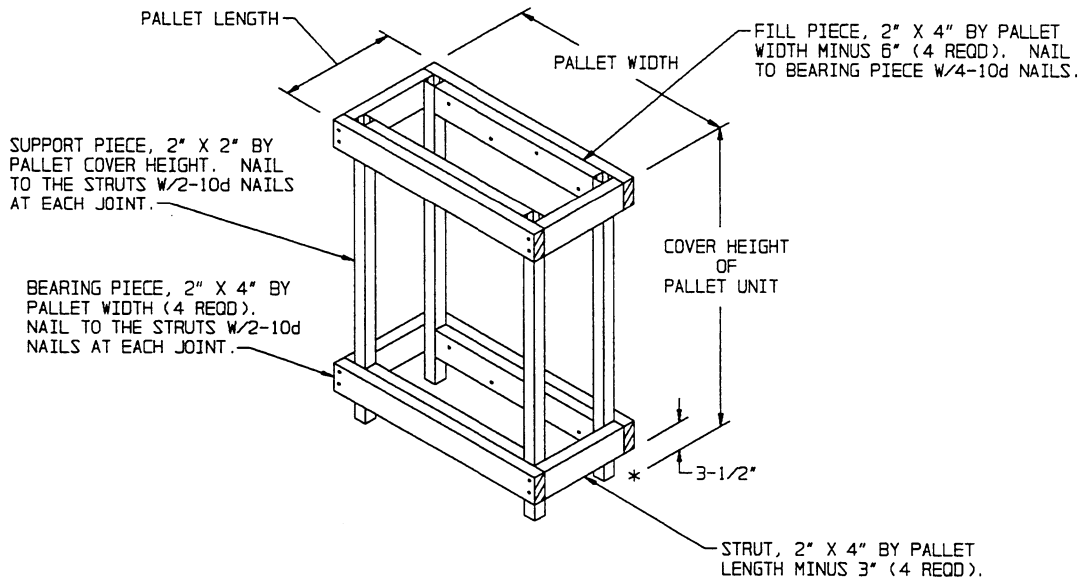

OMITTED UNIT ASSEMBLY

THE ASSEMBLY AS SPECIFIED ABOVE IS FOR USE IN PLACE OF AN OMITTED PALLET UNIT. IT WILL NEVER BE REQUIRED TO USE MORE THAN TWO ASSEMBLIES IN ANY ONE LOAD. CAUTION: AN ASSEMBLY OR ASSEMBLIES MUST ONLY BE PLACED WITHIN THE MIDDLE ROW OF A LOAD.

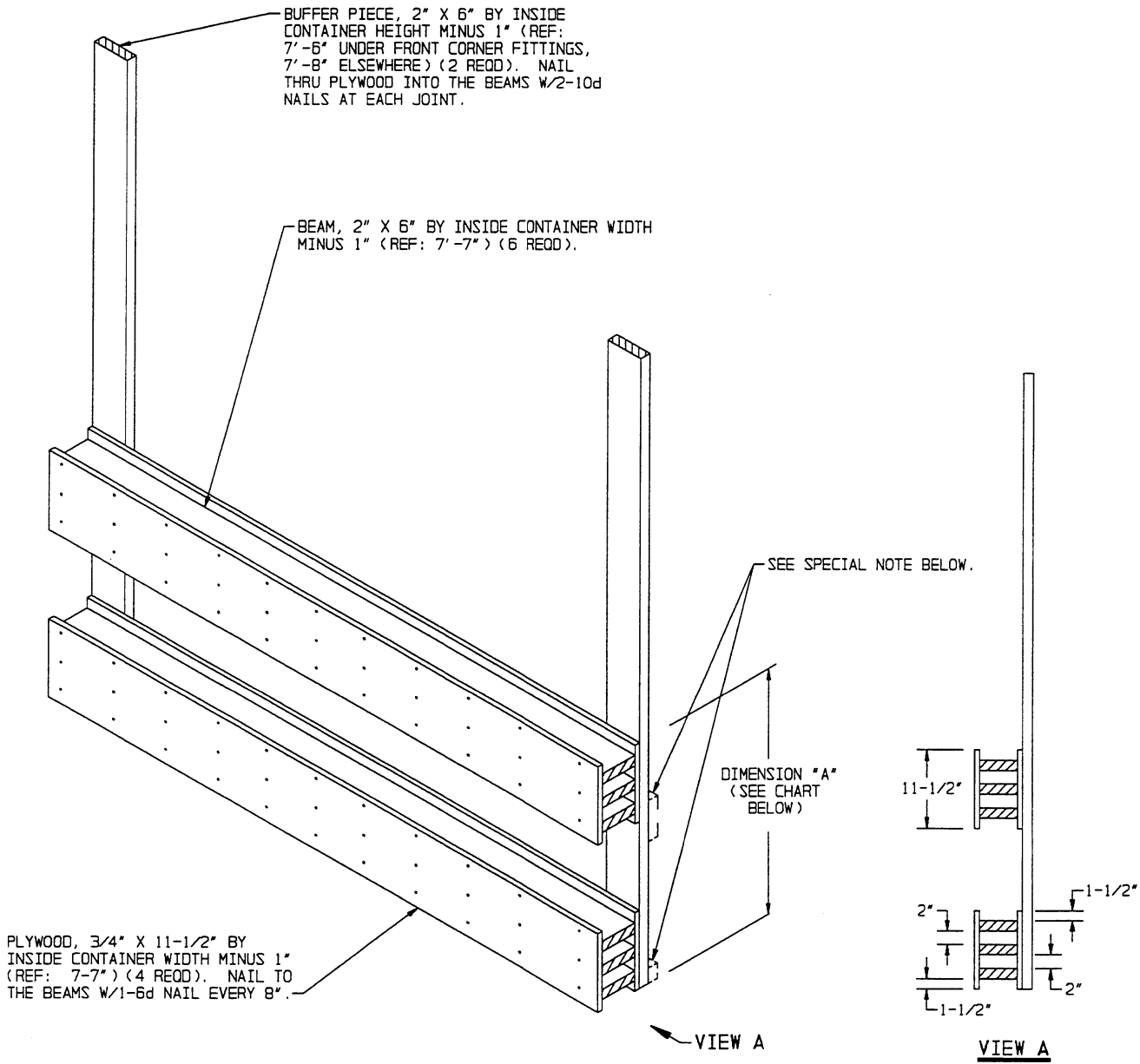

FORWARD/REAR BLOCKING ASSEMBLY

SPECIAL NOTE:

FOUR STRUT LEDGERS ARE REQUIRED ON REAR BLOCKING ASSEMBLIES USED IN LOADS WITH REAR STRUTS. THE LOWER STRUT LEDGERS WILL BE 2" X 4" X 2-1/4", AND THE UPPER STRUT LEDGERS WILL BE 2" X 4" X 6". LOCATE THE UPPER STRUT LEDGERS AT DIMENSION "A" MINUS 9-1/4". ALIGN THE STRUT LEDGERS WITH THE OUTER EDGES OF THE BUFFER PIECES AND NAIL W/2-10d NAILS EACH. THESE DIMENSIONS ARE FOR USE WITH DOUBLED STRUTS. IF SINGLE 4" X 4" STRUTS ARE USED, THE HEIGHT OF THE UPPER STRUT LEDGERS MUST BE INCREASED TO DIMENSION "A" MINUS 7-1/2" AND THE LENGTH OF THE LOWER STRUT LEDGERS MUST BE INCREASED TO 4".

FORWARD/REAR BLOCKING ASSEMBLY TYPE*	DIMENSION "A"
TYPE "A"	32-1/2"
TYPE "B"	40-1/2"
TYPE "C"	31-1/2"
TYPE "D"	39"
TYPE "E"	38-1/2"
TYPE "F"	49"

* THE "FORWARD/REAR BLOCKING ASSEMBLY TYPE" REFERS TO THE TYPES LISTED IN THE KEY NUMBERS FOR EACH LOAD. FOR EXAMPLE, THE LOAD ON PAGE 6 REQUIRES TYPE "A" ASSEMBLIES.

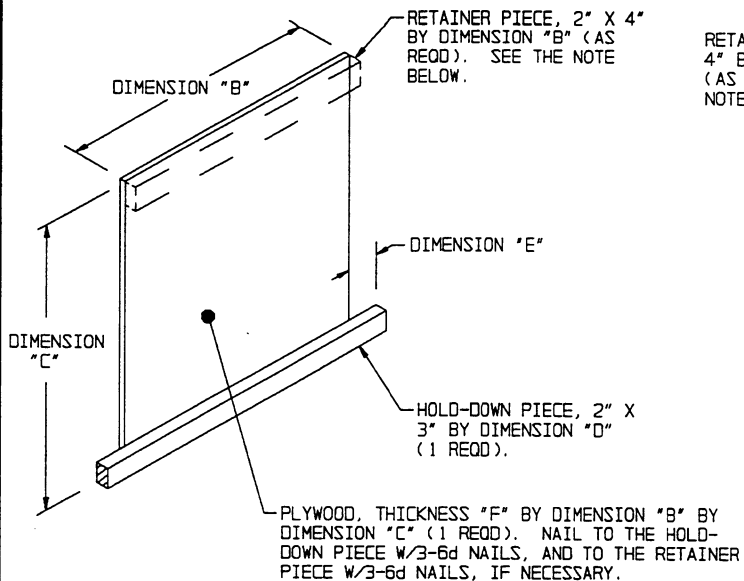

SEPARATOR GATE A

RETAINER PIECES ARE ONLY REQUIRED WHEN LOADING SINGLE (NOT BUNDLED) PALLET UNITS.

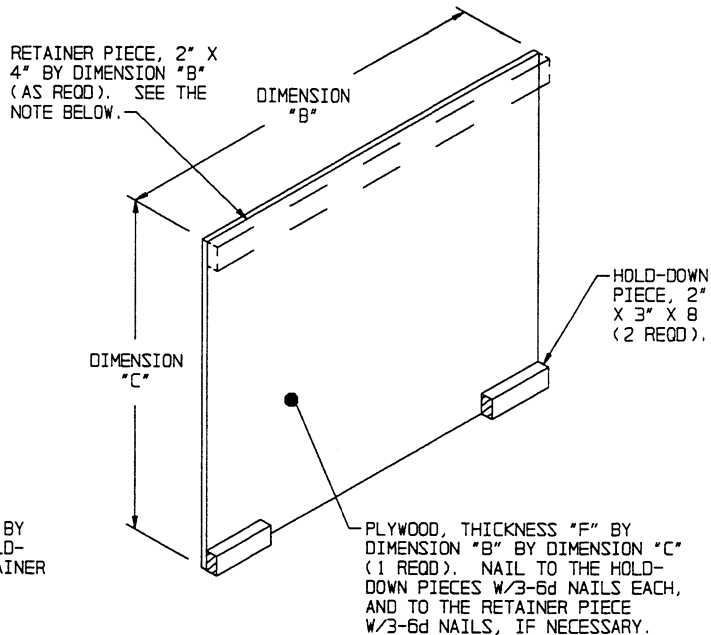

SEPARATOR GATE B

RETAINER PIECES ARE ONLY REQUIRED WHEN LOADING SINGLE (NOT BUNDLED) PALLET UNITS.

SEPARATOR GATE DIMENSION CHART					
SEPARATOR GATE TYPE *	DIMENSION "B"	DIMENSION "C"	DIMENSION "D"	DIMENSION "E"	THICKNESS "F"
TYPE "G"	32"	34"	40"	4"	3/4"
TYPE "H"	48"	42"	NA	NA	1/2"
TYPE "J"	48"	33"	NA	NA	1/2"
TYPE "K"	48"	41"	NA	NA	1/2"
TYPE "L"	32"	40"	38-1/2"	3-1/4"	1/2"

NA = NOT APPLICABLE

* THE "SEPARATOR GATE TYPE" REFERS TO THE TYPES LISTED IN THE KEY NUMBERS FOR EACH LOAD. FOR EXAMPLE, THE LOAD ON PAGE 8 REQUIRES SEPARATOR GATES "B", TYPE "H", WHICH MEANS DIMENSION "B" SHOULD BE 48", DIMENSION "C" SHOULD BE 42" AND THICKNESS "F" SHOULD BE 1/2".

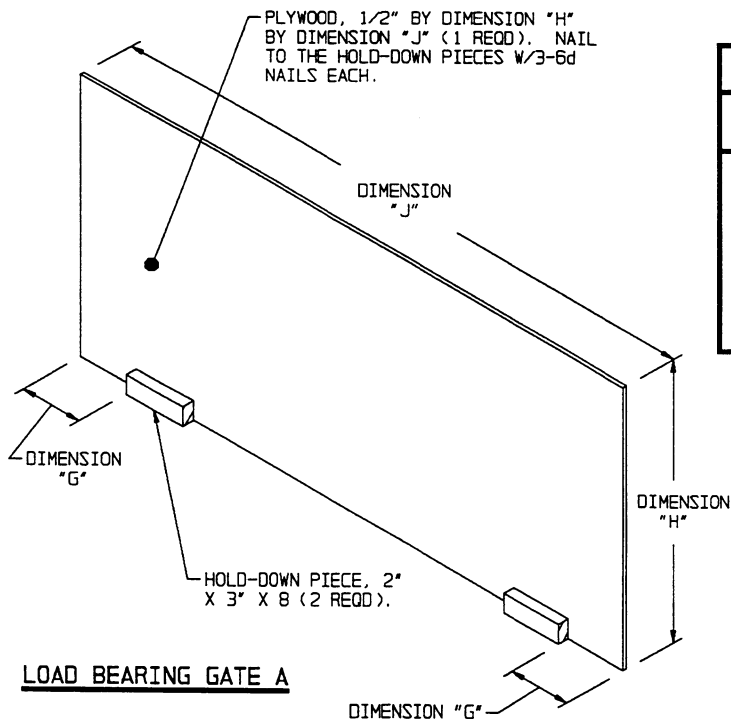

LOAD BEARING GATE A

LOAD BEARING GATE DIMENSION CHART			
LOAD BEARING GATE TYPE ⊗	DIMENSION "G"	DIMENSION "H"	DIMENSION "J"
TYPE "M"	8"	34"	6'-8"
TYPE "N"	11"	42"	7'-7"
TYPE "O"	11"	33"	7'-7"
TYPE "P"	11"	41"	7'-7"
TYPE "Q"	7-3/4"	40"	7'-0"

⊗ THE "LOAD BEARING GATE TYPE" REFERS TO THE TYPES LISTED IN THE KEY NUMBERS FOR EACH LOAD. FOR EXAMPLE, THE LOAD ON PAGE 6 REQUIRES TYPE "M" GATES, WHICH MEANS DIMENSION "G" SHOULD BE 8", DIMENSION "H" SHOULD BE 34", AND DIMENSION "J" SHOULD BE 6'-8".

BUFFER PIECE, 2" X 4" BY INSIDE CONTAINER HEIGHT MINUS 1" (REF: 7'-6" UNDER FRONT CORNER FITTINGS, 7'-8" ELSEWHERE) (1 REOD).

STRUT, 4" X 4" BY LENGTH TO SUIT OR AS SPECIFIED IN KEY NUMBERS (2 REOD) (DOUBLED). NOTE: STRUT LENGTHS WILL DEPEND ON THE VOID TO BE FILLED. SEE THE NOTE BELOW.

VERTICAL PIECE, 2" X 4" BY DIMENSION "K" PLUS 2-1/4" (1 REOD). NAIL TO THE STRUTS W/2-12d NAILS AT EACH JOINT.

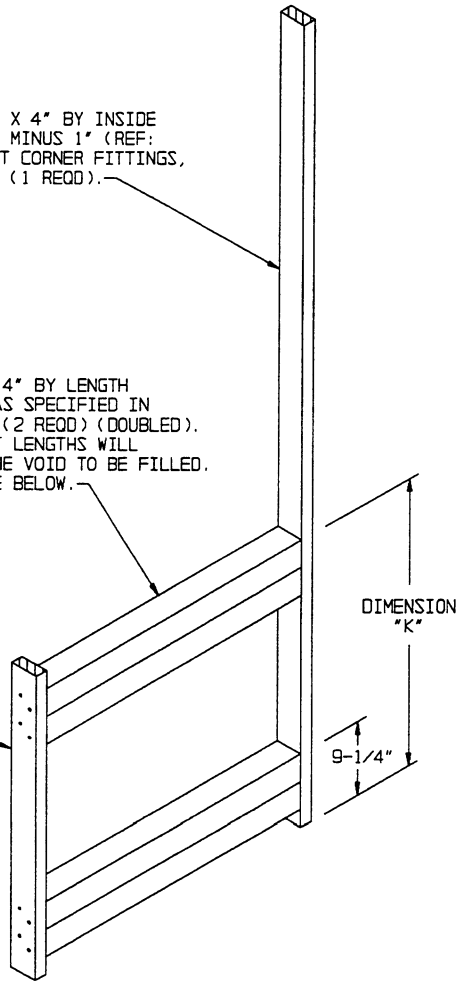

PALLET UNIT	DIMENSION "K"
155MM SLP, 8/SMALL WOODEN PALLET	30-1/4"
155MM SLP, 8/LARGE WOODEN PALLET	38-1/4"
155MM SLP, 8 SHORT/METAL PALLET	29-1/4"
155MM SLP, 8 TALL/METAL PALLET	36-3/4"
8" SLP, 6 SHORT/WOODEN PALLET	36-1/4"
8" SLP, 6 TALL/WOODEN PALLET	46-3/4"

FORWARD STRUT ASSEMBLY

IF THE TOTAL WEIGHT OF THE PALLET UNITS LOADED INTO A CONTAINER IS LESS THAN 20,000 POUNDS, SINGLE 4" X 4" STRUTS MAY BE USED INSTEAD OF DOUBLED STRUTS. RELOCATE THE LOWER STRUT AT 7-1/2".

VERTICAL PIECE, 4" X 4" BY INSIDE CONTAINER HEIGHT MINUS 1" (REF: 7'-4") (1 REOD).

STRUT LEDGER, 2" X 4" X 6" (2 REOD). NAIL TO THE VERTICAL PIECE W/2-10d NAILS.

STRUT LEDGER, 2" X 4" X 2-1/4" (2 REOD). NAIL TO THE VERTICAL PIECE W/2-10d NAILS.

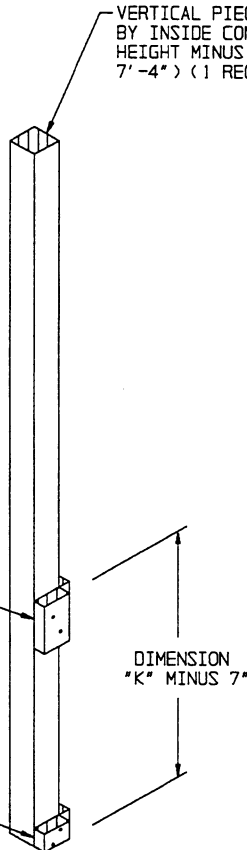

DOOR POST VERTICAL

IF SINGLE 4" X 4" STRUTS ARE USED IN THE FORWARD STRUT ASSEMBLY AND AT THE REAR OF THE LOAD AS DESCRIBED ABOVE AND ON PAGE 21, RELOCATE THE UPPER STRUT LEDGERS AT DIMENSION "K" MINUS 3-1/2" AND INCREASE THE LENGTH OF THE LOWER STRUT LEDGERS TO 4".

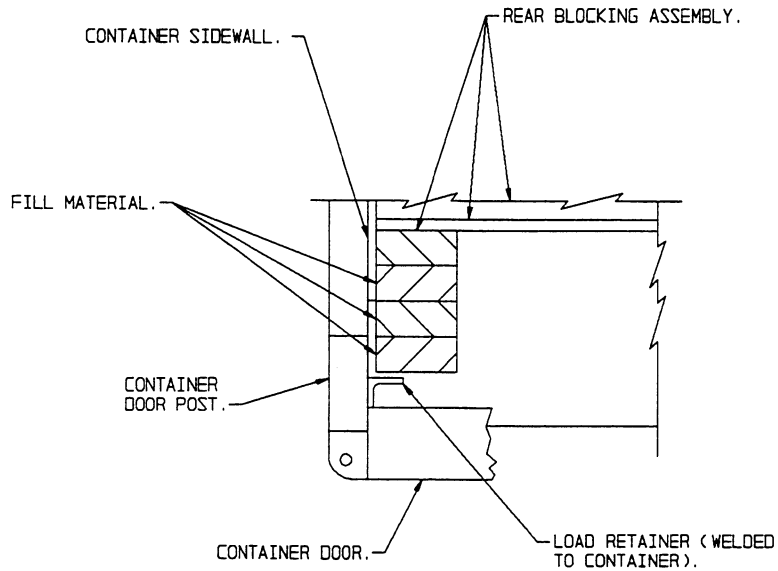

DETAIL A

A PARTIAL PLAN VIEW OF THE LEFT REAR PORTION OF THE CONTAINER IS SHOWN DEPICTING THE PROPER POSITION OF THE FILL MATERIAL AND ADJACENT DUNNAGE PIECES.

SPECIAL NOTE:

WHEN ISO CONTAINERS ARE NOT EQUIPPED WITH PRE-WELDED LOAD RETAINERS, AS DEPICTED IN "DETAIL A" ABOVE, DOOR POST VERTICALS, DOOR POST VERTICAL RETAINERS AND DOOR SPANNERS WILL BE REQUIRED FOR THE LOADS DEPICTED HEREIN. SEE VARIOUS LOADS WITHIN AMC DRAWING 19-48-4153-15PA1002 FOR EXAMPLES. SEE PAGE 26 FOR DETAILS OF THE METAL DOOR POST VERTICAL RETAINER.

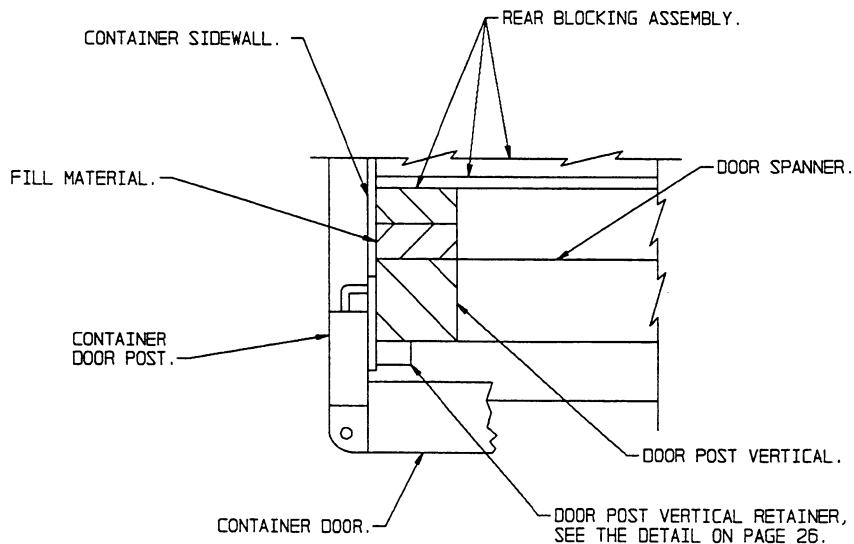

DETAIL B

A PARTIAL PLAN VIEW OF THE LEFT REAR PORTION OF THE CONTAINER IS SHOWN DEPICTING THE PROPER POSITION OF THE DOOR POST VERTICAL RETAINER AND ADJACENT DUNNAGE PIECES.

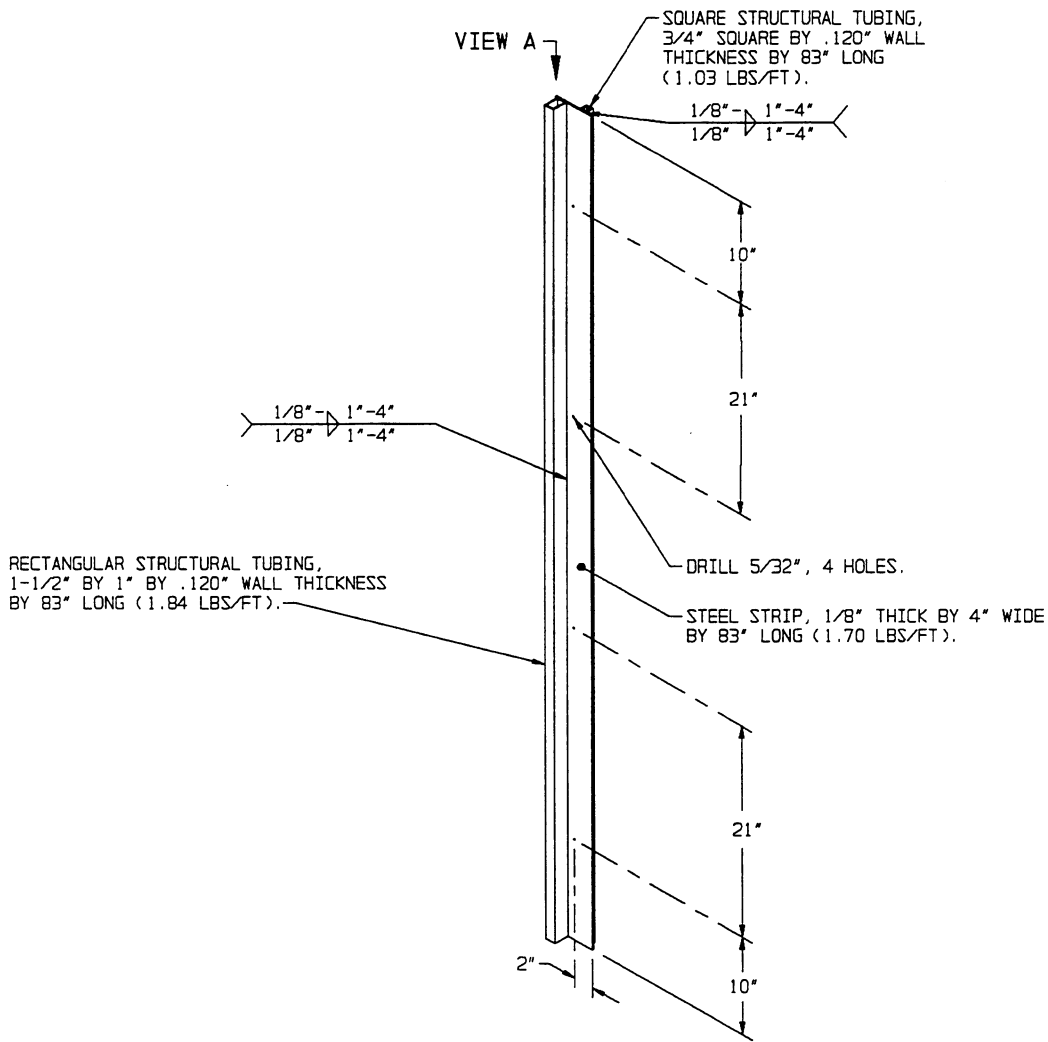
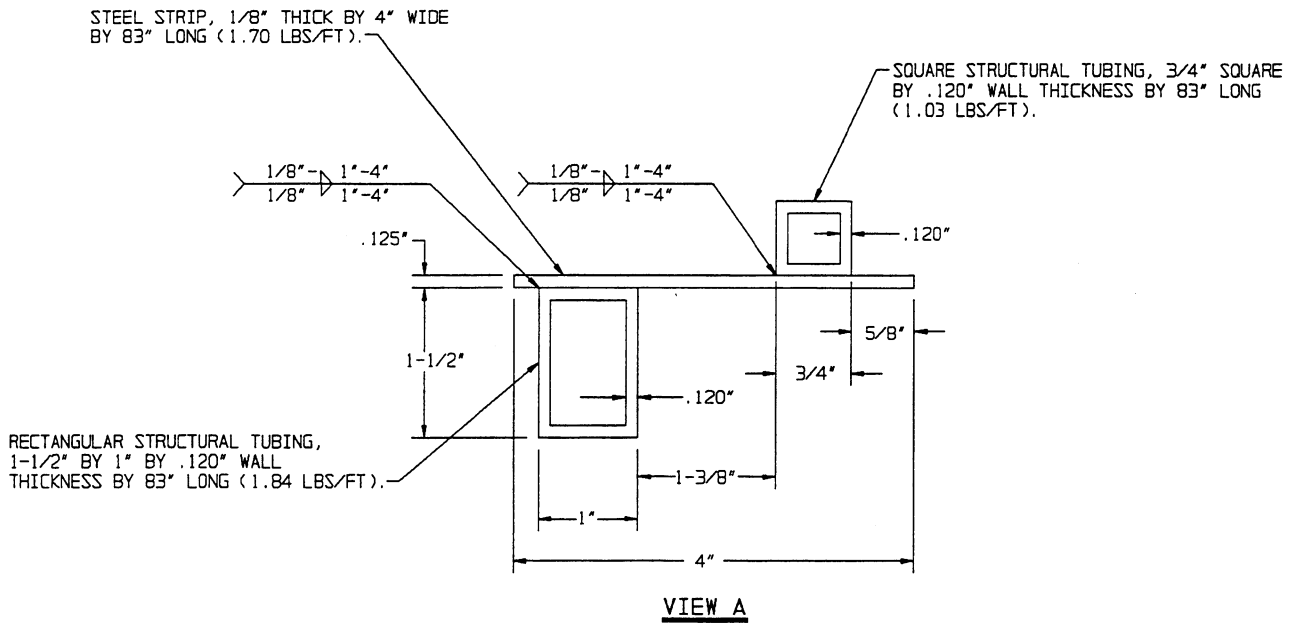

DOOR POST VERTICAL RETAINER

NOTE: THE ABOVE ASSEMBLY HAS BEEN SHOWN ROTATED 90° FROM THE ORIENTATION IN WHICH IT IS INSTALLED IN THE LEFT REAR CORNER OF THE CONTAINER. THE ASSEMBLY HAS BEEN ROTATED FOR HOLE LOCATION CLARITY.

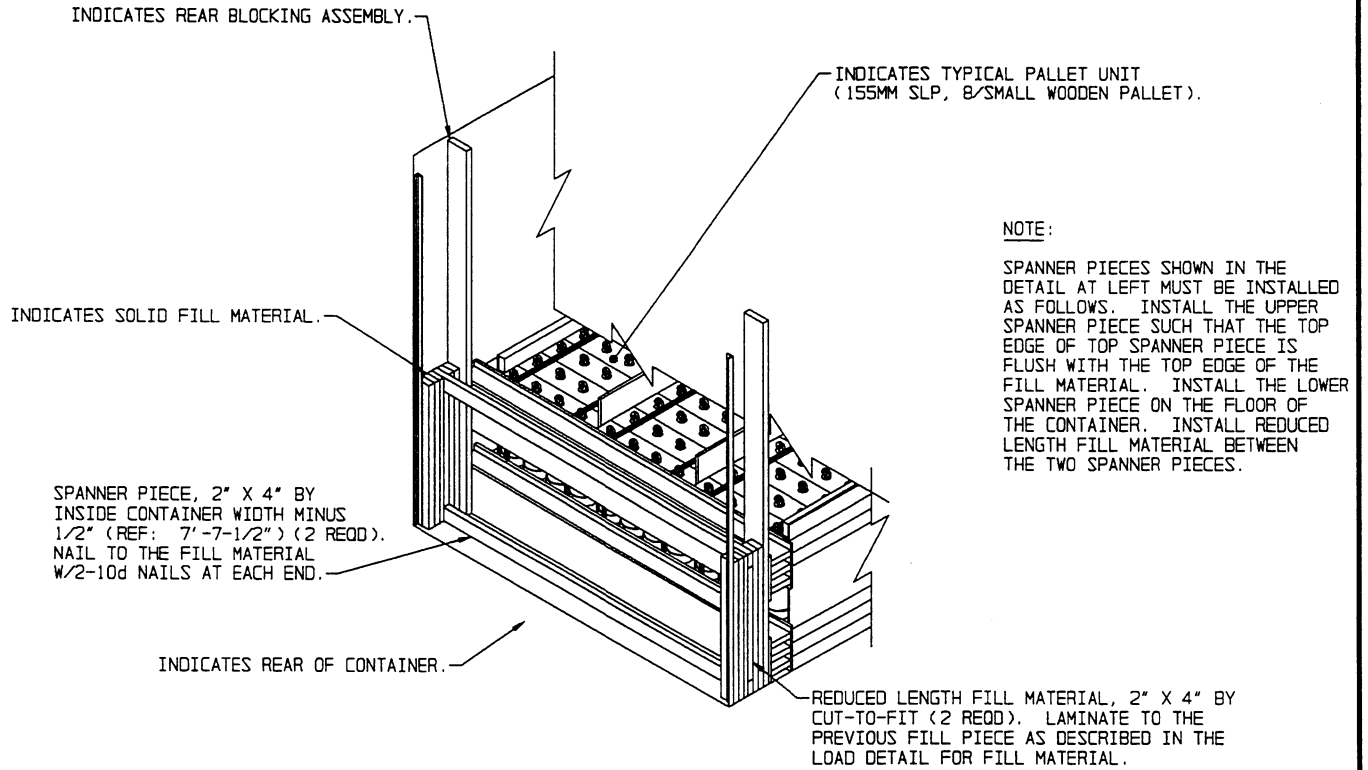

SPANNER/FILL INSTALLATION

THE DETAILS ABOVE AND BELOW DEPICT THE PROCEDURES TO BE USED WHEN INSTALLING MORE THAN 6" OF SOLID FILL MATERIAL AT THE REAR OF THE LOAD. ONE SET OF TWO SPANNER PIECES AND TWO REDUCED LENGTH FILL PIECES OR TWO DOOR SPANNER PIECES AND THE OPTIONAL STRUT LEDGERS MUST BE INSTALLED WHEN MORE THAN 6" OF SOLID FILL MATERIAL IS USED AT THE REAR OF THE LOAD. NOTE: THIS PROCEDURE APPLIES ONLY TO LOADS WITHOUT DOOR POST VERTICALS AND DOOR POST VERTICAL RETAINERS (AS DEPICTED IN "DETAIL A" ON PAGE 25).

