

STORAGE IN APPROVED MAGAZINES OF COMPLETE ROUNDS PACKED IN CYLINDRICAL METAL CONTAINERS AND UNITIZED ON A 39-1/2" X 44-1/2" METAL PALLET

PA116 SERIES CONTAINER

INDEX

ITEM

PAGE(S)

GENERAL NOTES AND MATERIAL SPECIFICATIONS-----	2
DETAILS-----	3
STORAGE PROCEDURES (EARTH COVERED MAGAZINES):	
81'-0", 60'-8" AND 40'-4" L X 26'-6" W X 12'-9" H IGLOO MAGAZINES --	4,5
81'-2" L X 26'-6" W X 12'-1-3/4" H ARCH TYPE MAGAZINE -----	6,7
80'-0" AND 40'-0" L X 25'-0" W X 12'-1-3/4" H ARCH TYPE MAGAZINES --	8,9
80'-0" AND 40'-0" L X 25'-0" W X 11'-0" H ARCH TYPE MAGAZINES ---	10,11
80'-0" AND 40'-0" L X 25'-0" W X 10'-0" H ARCH TYPE MAGAZINES ---	12,13
80'-0" L X 25'-0" W X 14'-0" H STRADLEY MAGAZINE -----	14,15
89'-0" L X 24'-10" W X 14'-4" H OVAL ARCH MAGAZINE -----	16,17
44'-7" AND 52'-0" DIA CORBETTA MAGAZINES -----	18,19
100'-8" L X 50'-0" W RECTANGULAR MAGAZINE -----	20,21
STORAGE IN 217'-0" L X 50'-0" W STANDARD ABOVE GROUND MAGAZINE ---	22,23
TYPICAL MULTIPLE-LOT STORAGE PROCEDURES:	
IGLOO AND ARCH TYPE MAGAZINES -----	24,25
STRADLEY AND OVAL-ARCH TYPE MAGAZINES -----	26,27
CORBETTA MAGAZINE -----	28,29
RECTANGULAR MAGAZINE -----	30

U.S. ARMY MATERIEL COMMAND DRAWING

APPROVED, U.S. ARMY ARMAMENT, MUNITIONS AND CHEMICAL COMMAND <i>David A. Prokoid</i> SMCAR-ESK	DRAFTSMAN	INGEBORG DEPPE			
	ENGINEER	M. DAEUMER			
APPROVED BY ORDER OF COMMANDING GENERAL, U.S. ARMY MATERIEL COMMAND <i>William F Ernst</i> U.S. ARMY DEFENSE AMMUNITION CENTER AND SCHOOL	SUPPLY ENGINEERING DIVISION	<i>Thomas J Michel</i>			
	LOGISTICS ENGINEERING OFFICE	<i>William F Ernst</i>			
JANUARY 1987					
REVISION NO. 2	AUGUST 1994	CLASS	DIVISION	DRAWING	FILE
SEE THE REVISION LISTING ON PAGE 2		19	48	4145/ 8A	1-2-3-4-14 22 PM1003

DO NOT SCALE

GENERAL NOTES

- A. THIS DOCUMENT HAS BEEN PREPARED AND ISSUED IN ACCORDANCE WITH AR 74D-1 AND AUGMENTS TM 743-200-1 (CHAPTER 5).
- B. THE STORAGE PROCEDURES DEPICTED WITHIN THIS DOCUMENT ARE APPLICABLE FOR STORAGE IN VARIOUS TYPES AND SIZES OF MAGAZINES. THE STORAGE PROCEDURES DEPICTED FOR THE SPECIFIC TYPES OF MAGAZINES MAY ALSO BE UTILIZED TO STORE COMPLETE ROUND PALLET UNITS IN OTHER TYPES OF APPROVED MAGAZINES. MINOR ADJUSTMENTS MAY BE MADE TO FACILITATE STORAGE IN OTHER TYPES OF MAGAZINES, HOWEVER, THE BASIC PRINCIPLES AS DEPICTED HEREIN WILL BE FOLLOWED.
- C. THE STORAGE PROCEDURES SPECIFIED HEREIN ARE APPLICABLE FOR THE 120MM COMPLETE ROUND PACKED IN THE PA116 SERIES CONTAINER AND UNITIZED ON A 39-1/2" LONG BY 44-1/2" WIDE PALLET WITH COVER. SUBSEQUENT REFERENCE TO PALLET UNIT MEANS THE PALLET UNIT WITH AMMUNITION ITEMS.
- D. FOR PALLET UNIT DETAILS, REFER TO U.S. ARMY AMC UNITIZATION DRAWING 19-48-4079/7A-20PM1002 AND THE PICTORIAL VIEW ON PAGE 3.
- E. CAUTION: THE ALLOWABLE "EXPLOSIVE LIMIT" ESTABLISHED FOR A MAGAZINE IS NOT TO BE EXCEEDED. THIS LIMITATION MAY REQUIRE A QUANTITY REDUCTION FROM THE STORAGE AS SHOWN.
- F. STORED PALLET UNITS MUST NOT CONTACT THE WALLS OF A MAGAZINE. TO PROVIDE FOR THIS MANDATORY CLEARANCE REQUIREMENT, UNITS MAY BE ELIMINATED FROM THE DEPICTED STORAGE PATTERN AS NECESSARY.
- G. AISLE DIMENSIONS SHOWN FOR STORAGE PROCEDURES IN MAGAZINES MAY BE ADJUSTED TO SUIT LOCAL CONDITIONS, VARIATIONS IN PALLET UNIT DIMENSIONS, AND/OR AVAILABLE MATERIALS HANDLING EQUIPMENT.
- H. THE MAXIMUM FLOOR LOAD FOR A MAGAZINE AS PRESCRIBED BY LOCAL STANDARDS WILL NOT BE EXCEEDED.
- J. THE HEIGHT OF THE PACKAGE GUARD ON SOME FORKLIFT TRUCKS MAY NOT PERMIT PLACEMENT OF SOME TOP LAYER UNITS IN THE STACKS SHOWN IN THE STORAGE VIEWS HEREIN, UNLESS TWO UPPER PALLET UNITS ARE HANDLED AS ONE LIFT OR THE PACKAGE GUARD IS REMOVED (TINE CARRIAGE WILL IN MOST INSTANCES PROVIDE ADEQUATE PACKAGE GUARD PROTECTION). ONLY A FORKLIFT TRUCK OF ADEQUATE CAPACITY WILL BE USED WHEN LIFTING TWO PALLET UNITS AS ONE LIFT.
- K. THE MATERIALS HANDLING EQUIPMENT (MHE) AREA SHOULD BE OF SUFFICIENT DIMENSION TO PERMIT "TURN-AROUND" OF MHE WHEN STORING IN MAGAZINE NOT EQUIPPED WITH PROPERLY SIZED APRONS FOR THAT PURPOSE. THE MHE AISLE IN ALL MAGAZINES IS BASED ON A FIGURE WHICH IS AT LEAST 7'-7" PLUS THE LENGTH OR WIDTH OF THE PALLET UNIT, AS APPLICABLE, OR THE LENGTH OF THE FORKLIFT TRUCK TINES (40") WHICHEVER IS THE GREATEST. IF THE AVAILABLE MHE PERMITS, ADDITIONAL PALLET UNITS MAY BE STORED WITHIN THE MHE AREA AND/OR OTHER AVAILABLE AREA OF THE MAGAZINE.
- L. THE USE OF "FLOOR DUNNAGE" UNDER METAL PALLETS IS OPTIONAL, ALTHOUGH THE USE OF THIS TYPE OF DUNNAGE IS DELINEATED WITHIN THIS STORAGE PROCEDURE DRAWING. THE PURPOSE OF FLOOR DUNNAGE IS TO HELP KEEP THE RUNNERS OF A PALLET DRY, THUS AIDING IN PREVENTING DETERIORATION DUE TO CORROSION. THEREFORE, FLOOR DUNNAGE SHOULD BE USED WHEN STORING IN A MAGAZINE THAT IS KNOWN TO HAVE A "DAMP" FLOOR. ALSO, IN LIEU OF USING ONE-INCH THICK FLOOR DUNNAGE AS SPECIFIED, THE USE OF THICKER FLOOR DUNNAGE MAY BE REQUIRED, AND SHOULD BE USED, TO ACHIEVE THE DESIRED OBJECTIVE. NOTE: ISOMETRIC VIEWS WITHIN THIS DRAWING DO NOT DEPICT ALL FLOOR DUNNAGE THAT IS REQUIRED WHEN DUNNAGE IS USED. FLOOR DUNNAGE IS SHOWN AT SOME LOCATIONS TO PROVIDE POSITIONING GUIDANCE.

MATERIAL SPECIFICATIONS

LUMBER - - - - - SEE TM 743-200-1, (DUNNAGE LUMBER)
AND FED SPEC MM-L-751.

(GENERAL NOTES CONTINUED)

- M. DUNNAGE LUMBER SPECIFIED THROUGHOUT THIS PROCEDURAL DRAWING IS OF NOMINAL SIZE. FOR EXAMPLE, 1" X 6" MATERIAL IS ACTUALLY 3/4" THICK BY 5-1/2" WIDE.
- N. STORAGE OF MULTIPLE LOTS IN A MAGAZINE WILL REQUIRE CAREFUL PRE-PLANNING SO AS TO INSURE MHE ACCESSIBILITY TO ANY LOT IN ACCORDANCE WITH REQUIREMENTS SET FORTH IN THE APPLICABLE "SPECIAL NOTES" SECTIONS OF THE MULTIPLE LOT STORAGE PROCEDURES TYPICALLY SHOWN ON PAGES 24 THRU 30.
- O. ALTHOUGH SPECIFIC PROCEDURES ARE INCLUDED IN THIS DRAWING FOR STORING MULTIPLE LOTS WITHIN ONE STRUCTURE, THE BASIC STORAGE PATTERNS AS SHOWN ON PAGES 4 THRU 23 CAN ALSO BE ADAPTED FOR THE STORING OF MORE THAN ONE LOT. LOTS WHEN STORED IN ACCORDANCE WITH A BASIC STORAGE PATTERN MAY BE STORED WITH ONE OR MORE ROWS USED FOR EACH LOT. A SPACE OF APPROXIMATELY 1" WILL HAVE TO BE LEFT BETWEEN ADJACENT ROWS CONTAINING DIFFERENT LOTS. IN BASIC STORAGE PATTERNS WHERE THE WIDTH OF A ROW IS ESTABLISHED BY THE 44-1/2" UNIT-DIMENSION, EACH ROW MAY BE A DIFFERENT LOT AND READILY REMOVABLE. IN BASIC STORAGE PATTERNS WHERE THE WIDTH OF A ROW IS ESTABLISHED BY THE 39-1/2" UNIT-DIMENSION, A LOT MUST CONSIST OF TWO OR MORE ROWS TO PROVIDE ADEQUATE SPACE TO ACCOMMODATE THE WIDTH OF A FORKLIFT TRUCK FOR STORING OR REMOVING THE LOT. HOWEVER, WHEN THE SIZE OF THE LOT REQUIRES THE SPACE OF ONLY ONE ROW, IT IS PERMISSIBLE TO STORE THAT LOT WITH THE 44-1/2" UNIT-DIMENSION ESTABLISHING THE WIDTH OF THAT ROW, PROVIDING THE STORAGE PRINCIPLES SPECIFIED ARE FOLLOWED AS CLOSELY AS POSSIBLE. THE 1" SPACE BETWEEN LOTS, AS STATED ABOVE WILL NOT BE EXCEEDED SOLELY TO ACCOMMODATE THE WIDTH OF A FORKLIFT TRUCK. FOR ADDITIONAL REQUIREMENTS AND GUIDANCE, SEE THE SPECIAL NOTES FOR MULTIPLE-LOT STORAGE ON PAGES 24 THRU 30.
- P. ANY "LIGHT" PALLET UNIT THAT DOES NOT CONTAIN A FULL QUANTITY OF COMPLETE ROUNDS WILL NOT BE BURIED IN STORAGE. IT MUST BE POSITIONED ADJACENT TO AN AISLE, PREFERABLY IN FRONT OF THE LOT.
- Q. PORTIONS OF THE MAGAZINES, SUCH AS SIDEWALLS, END WALLS, AND ROOFS, HAVE NOT BEEN SHOWN IN THE STORAGE VIEWS FOR CLARITY PURPOSES.
- R. A PRODUCTION OR STORAGE FACILITY IS AUTHORIZED TO HAVE ONE INCOMPLETE, UNBANDED PARTIAL UNIT LOAD PER LOT IN A STORAGE STRUCTURE. PRIOR TO SHIPMENT OF A PARTIAL UNIT, A LAYER MUST BE COMPLETED BY POSITIONING OF ONE OR MORE FILLER CONTAINERS AS DELINEATED BY DRAWING 19-48-4079/7A-20PM1002. THE UNIT MUST THEN BE REBANDED WITH THE SAME SIZE AND QUANTITY OF STRAPS AS THE ORIGINAL UNIT.
- S. WHEN STORING 120MM CARTRIDGES, DODAC'S 1315-C791 AND 1315-C792 THE OPENING END OF THE CONTAINERS FOR THE OUTER STACKS, SHALL BE LOCATED INWARD TO PROVIDE ADDITIONAL SECURITY WHILE IN STORAGE.

REVISIONS

REVISION NO. 1, DATED JANUARY 1990 CONSISTS OF:

1. ADDING GENERAL NOTE "S", AND NOTES REFERRING TO IT.

REVISION NO. 2, DATED AUGUST 1994 CONSISTS OF:

1. UPDATING DRAWING FORMAT AND GENERAL NOTES

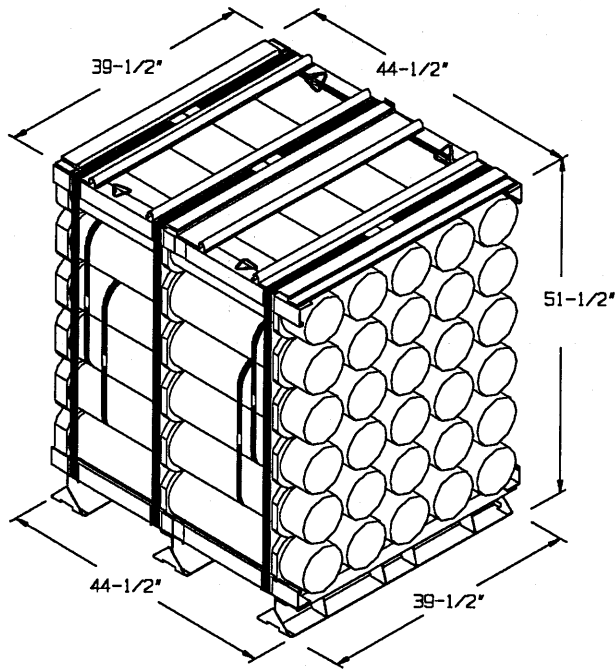

ISOMETRIC VIEW

30 CONTAINERS PER PALLET.
 UNIT WEIGHT - - - - 2,421 LBS (APPROX)
 CUBE - - - - - 52.4 CUBIC FEET

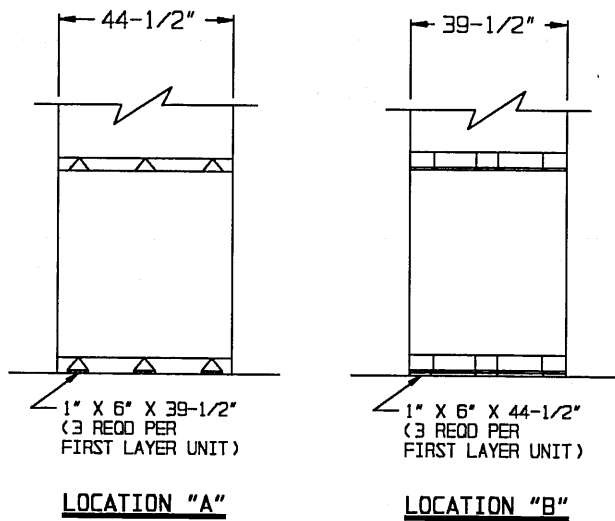

FLOOR DUNNAGE

SEE GENERAL NOTE
 L ON PAGE 2.

DETAILS

STORAGE IN 81'-0" IGLOO

(12'-9" HIGH)

ITEM	QUANTITY
PALLET UNITS - - - -	234
PA116 CONTAINERS - - -	7,020

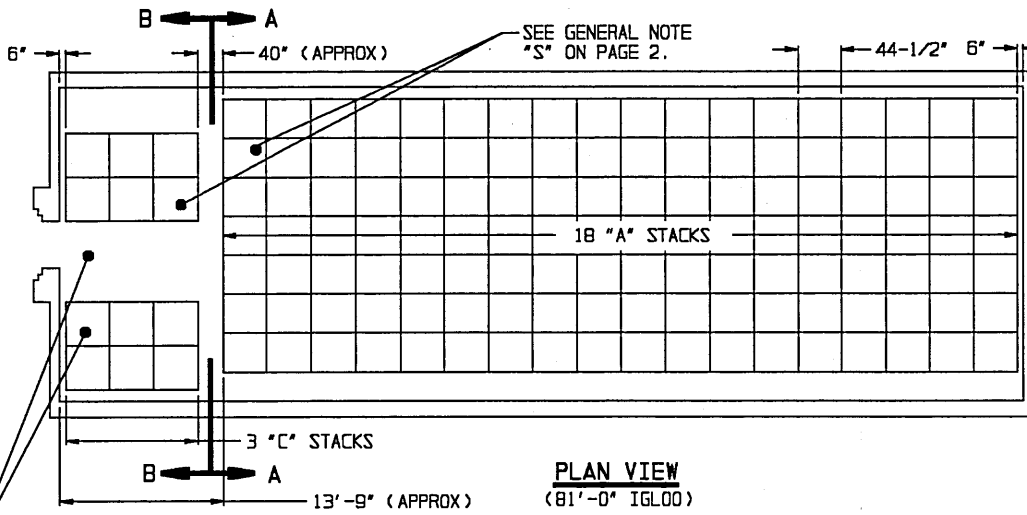

PLAN VIEW
(81'-0" IGLOO)

SEE GENERAL NOTE *K* ON PAGE 2.

SEE GENERAL NOTE *F* ON PAGE 2.

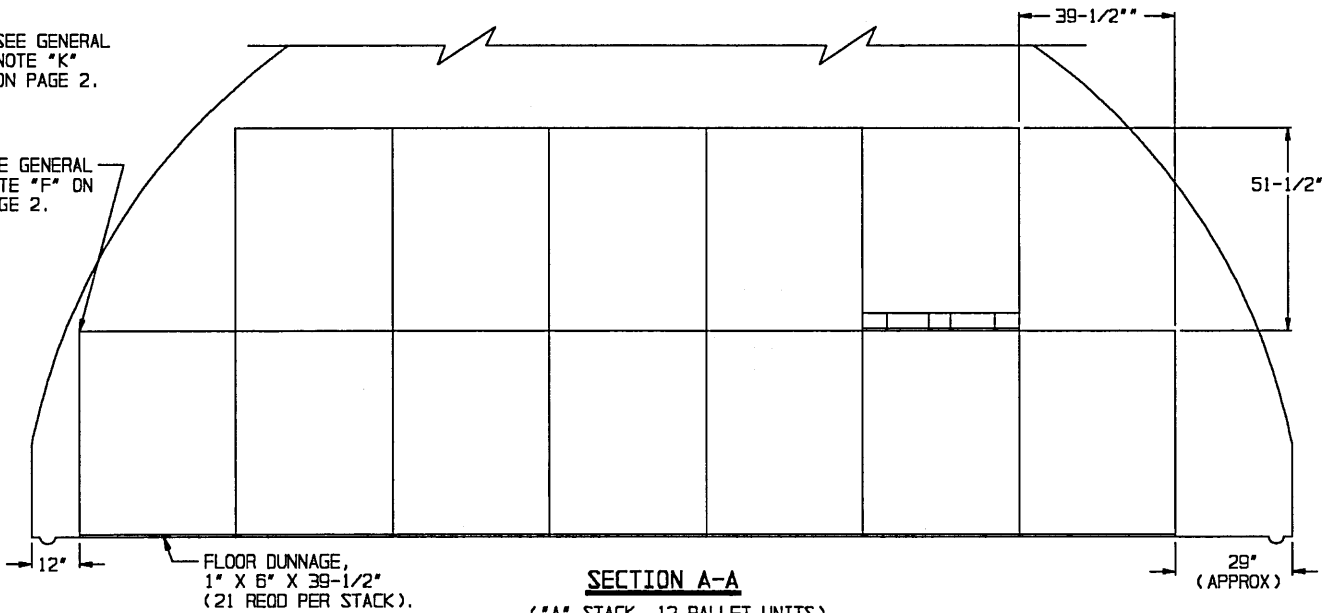

SECTION A-A
(*A* STACK, 12 PALLET UNITS)

INDICATES OUTLINE OF DOOR OPENING.

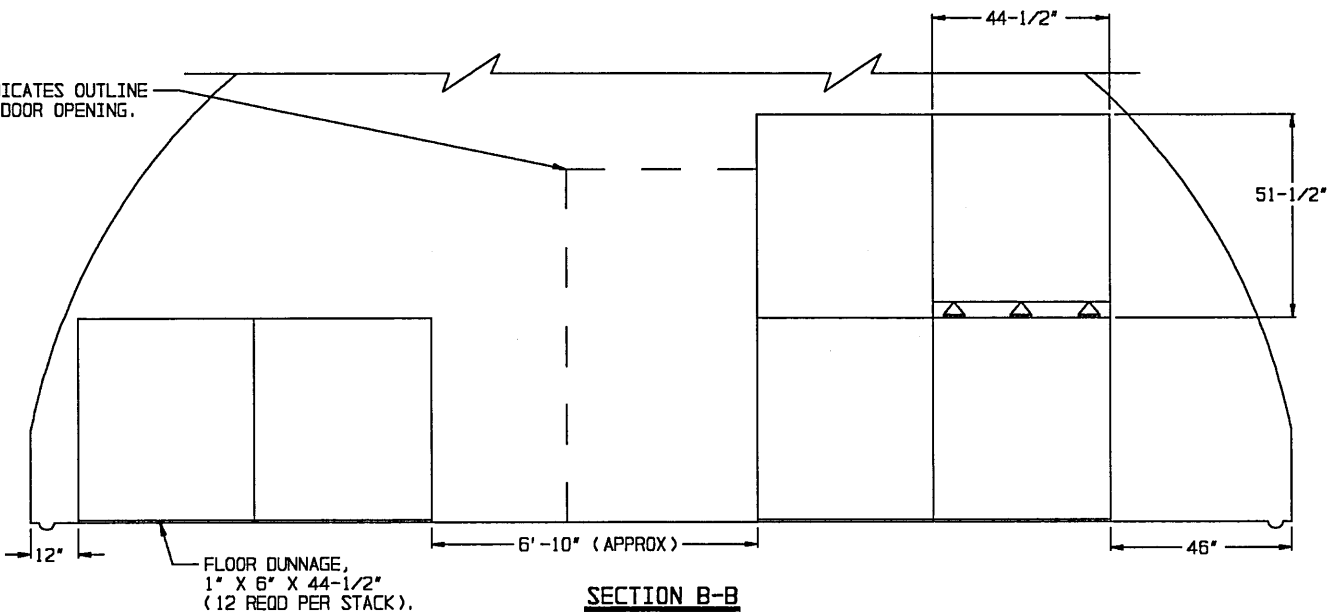

SECTION B-B
(*C* STACK, 6 PALLET UNITS)

STORAGE IN 60'-8" IGLOO

(12'-9" HIGH)

ITEM	QUANTITY
PALLET UNITS - - - - -	174
PA116 CONTAINERS - - - -	5,220

STORAGE IN 40'-4" IGLOO *

(12'-9" HIGH)

ITEM	QUANTITY
PALLET UNITS - - - - -	102
PA116 CONTAINERS - - - -	3,060

* 7 A-STACKS
3 C-STACKS

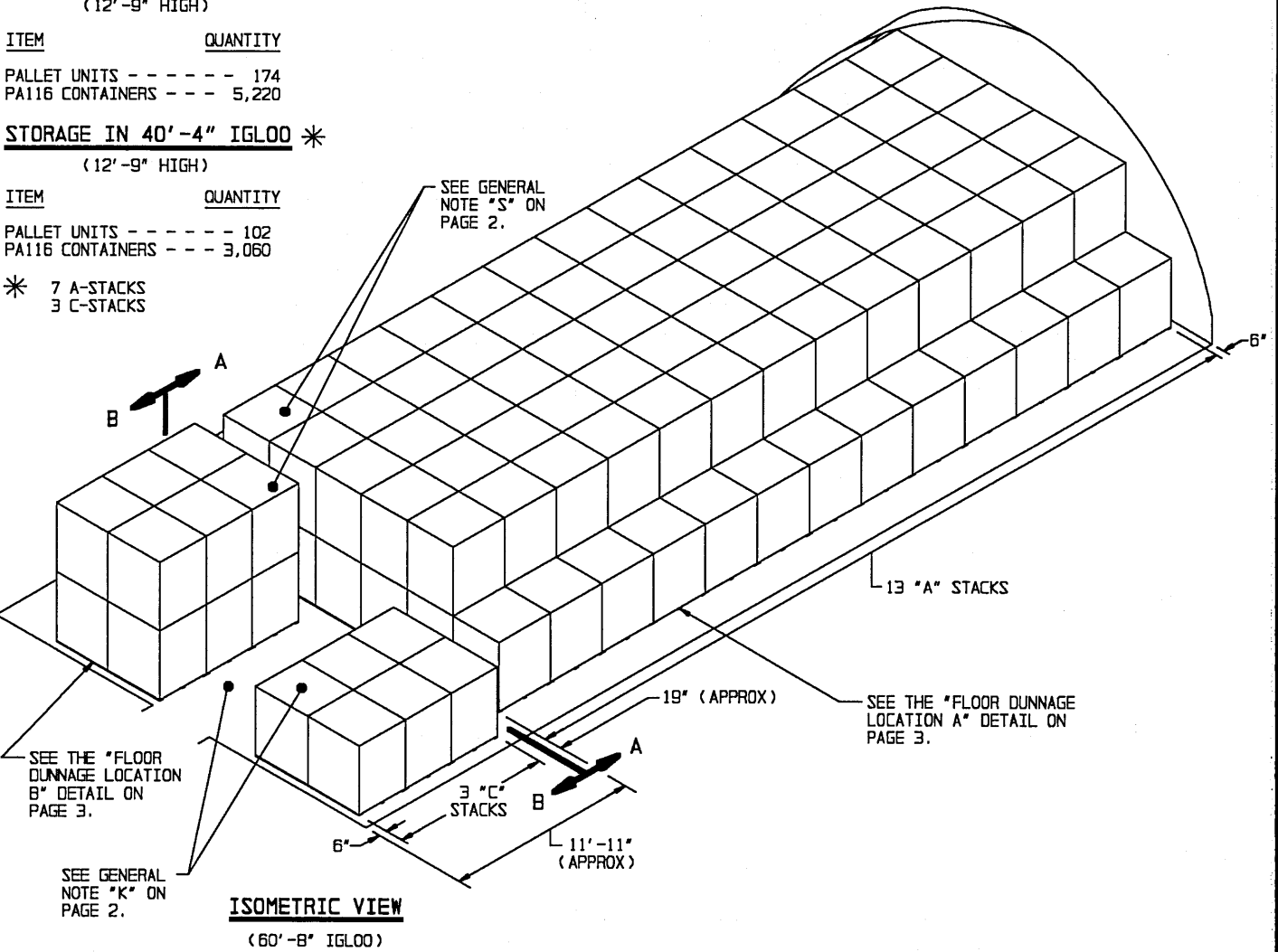

FOR "GENERAL NOTES", AND "MATERIAL SPECIFICATION" SEE PAGE 2.

BILL OF MATERIAL (PER STACK) * *		
TYPE STACK	1" X 6" DUNNAGE LUMBER	
	LINEAR FEET	BOARD FEET
A	70	35
C	45	23

* * SEE GENERAL NOTE "L" ON PAGE 2.

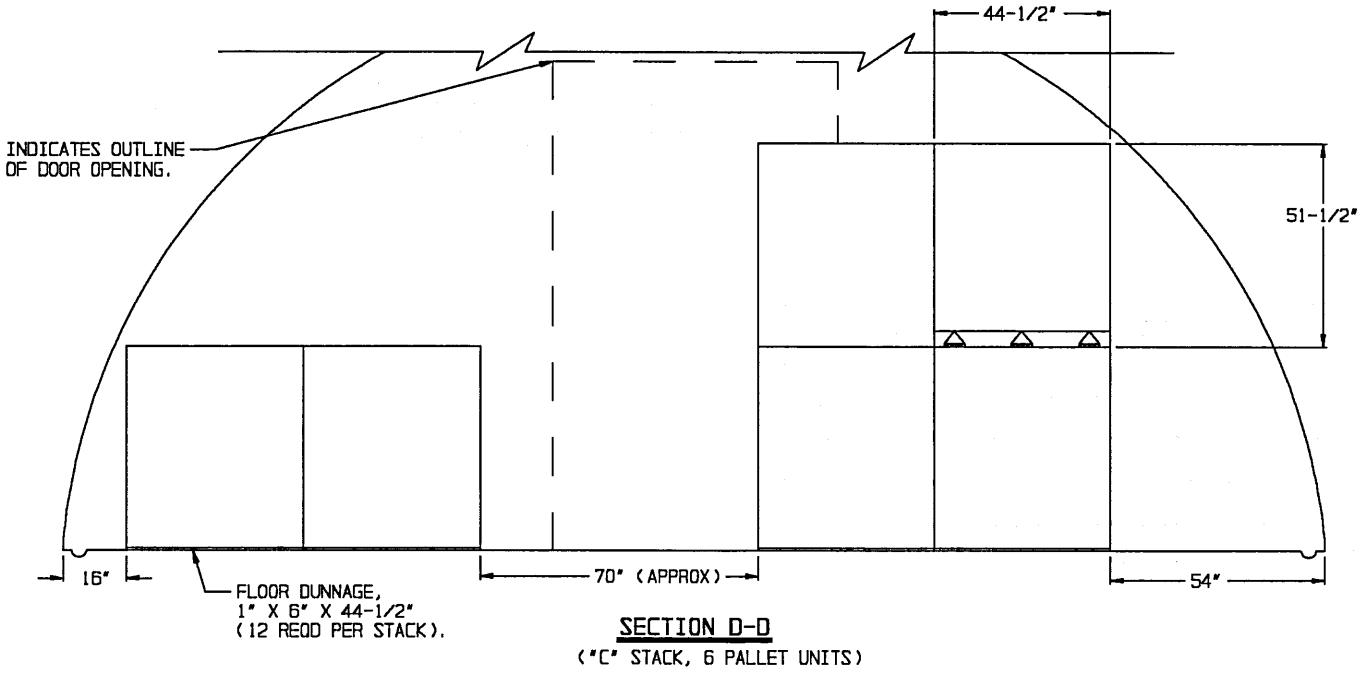
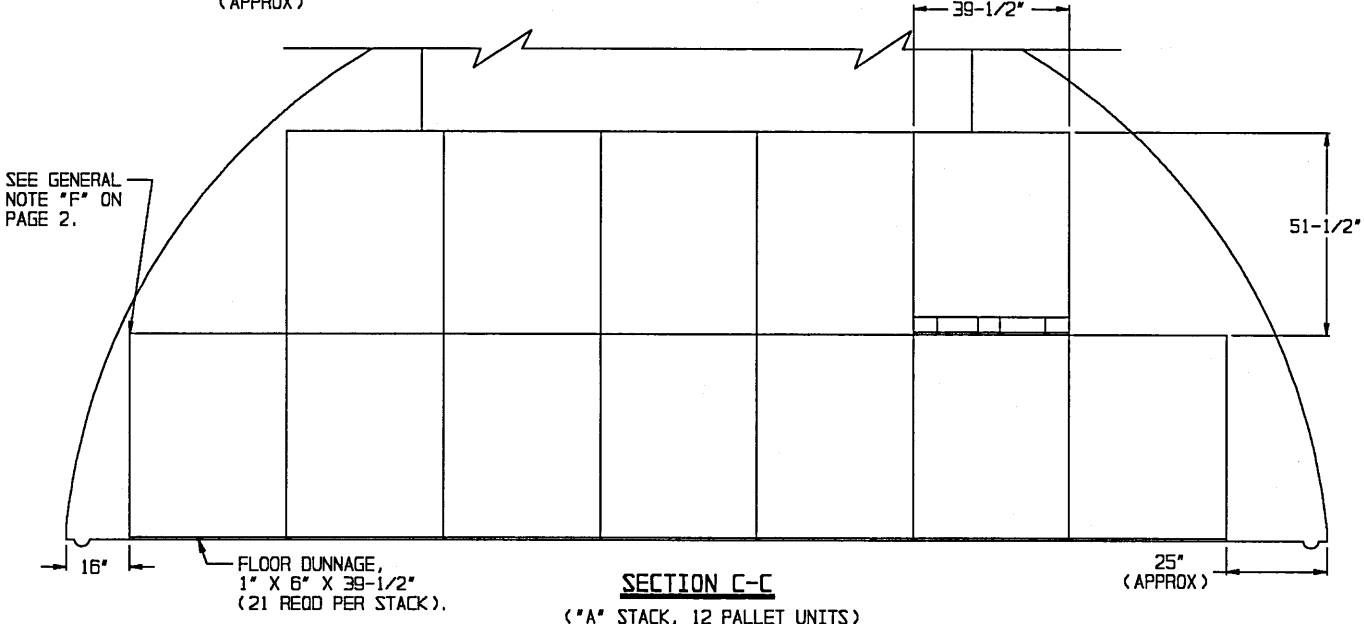
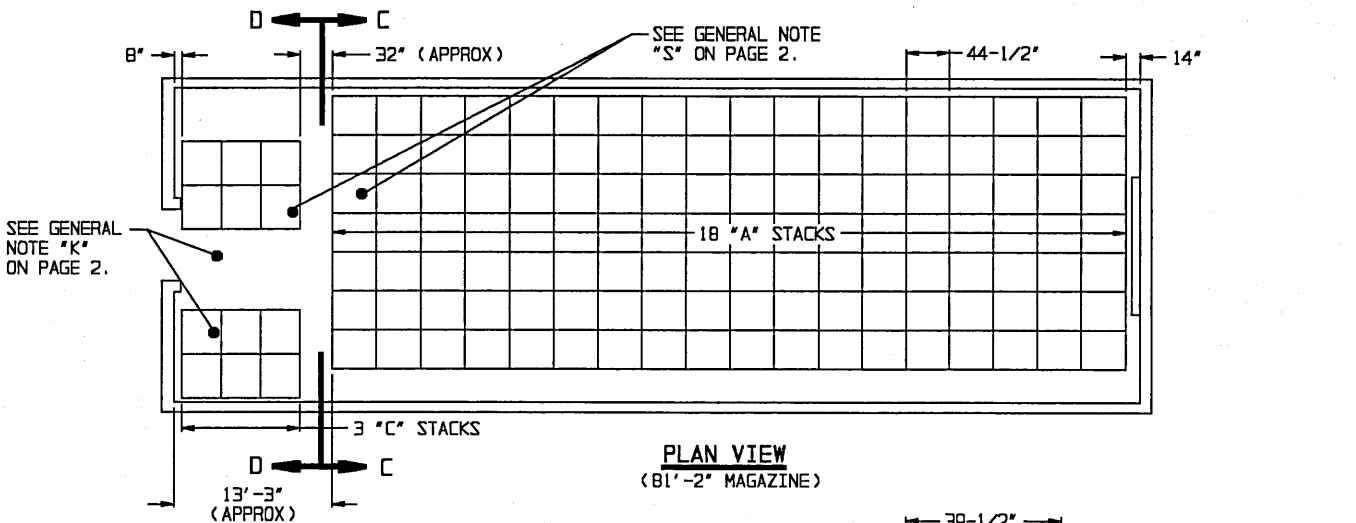

STORAGE IN 81'-2" MAGAZINE

(12'-1-3/4" HIGH)

ITEM	QUANTITY
PALLET UNITS - - - - -	234
PA116 CONTAINERS - - - - -	7,020

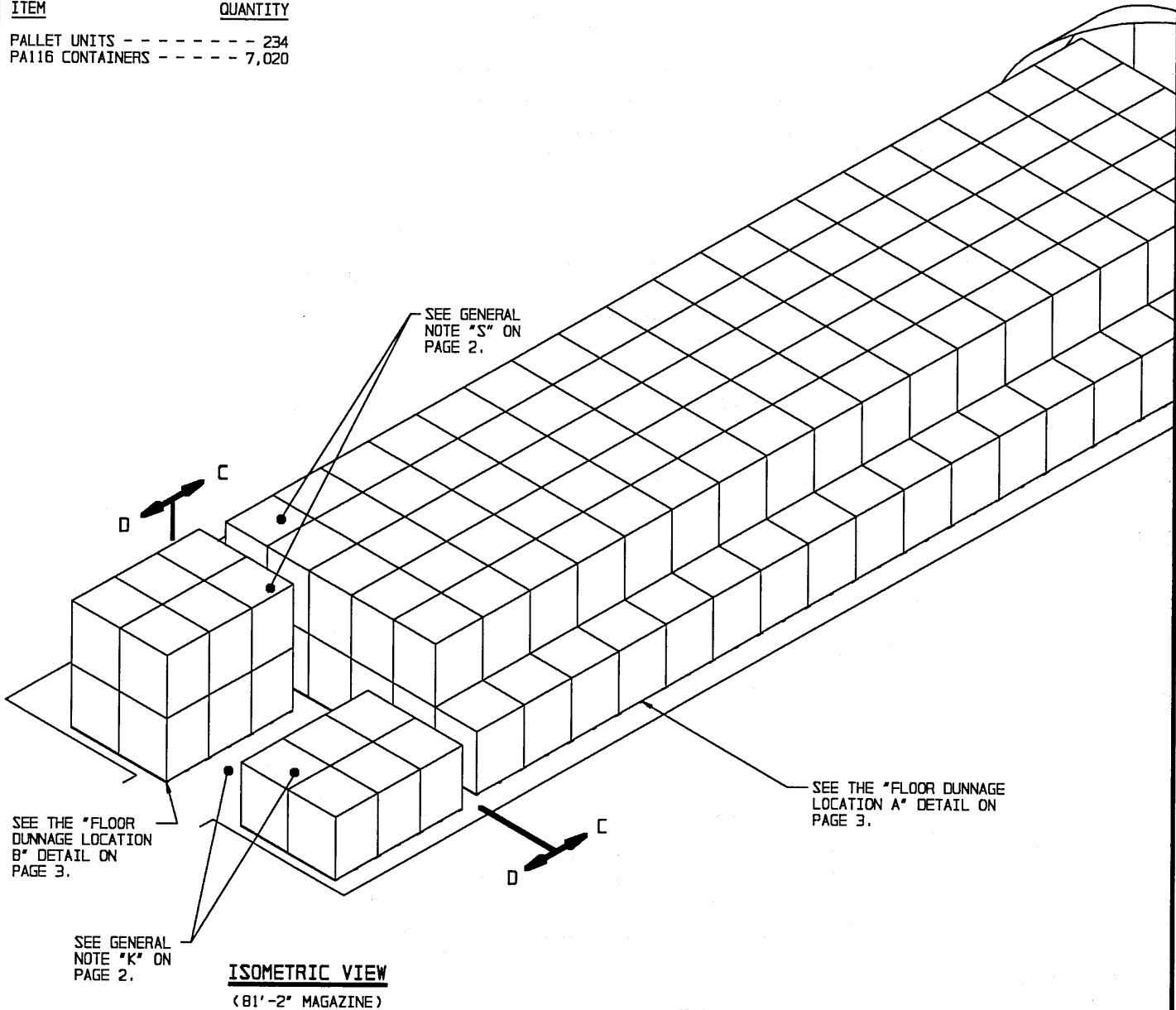

ISOMETRIC VIEW
(81'-2" MAGAZINE)

FOR "GENERAL NOTES", AND "MATERIAL SPECIFICATION" SEE PAGE 2.

BILL OF MATERIAL (PER STACK) *		
TYPE STACK	1" X 6" DUNNAGE LUMBER	
	LINEAR FEET	BOARD FEET
A	70	35
C	45	23

* SEE GENERAL NOTE "L" ON PAGE 2.

STORAGE IN 80'-0" MAGAZINE

(12'-1-3/4" HIGH)

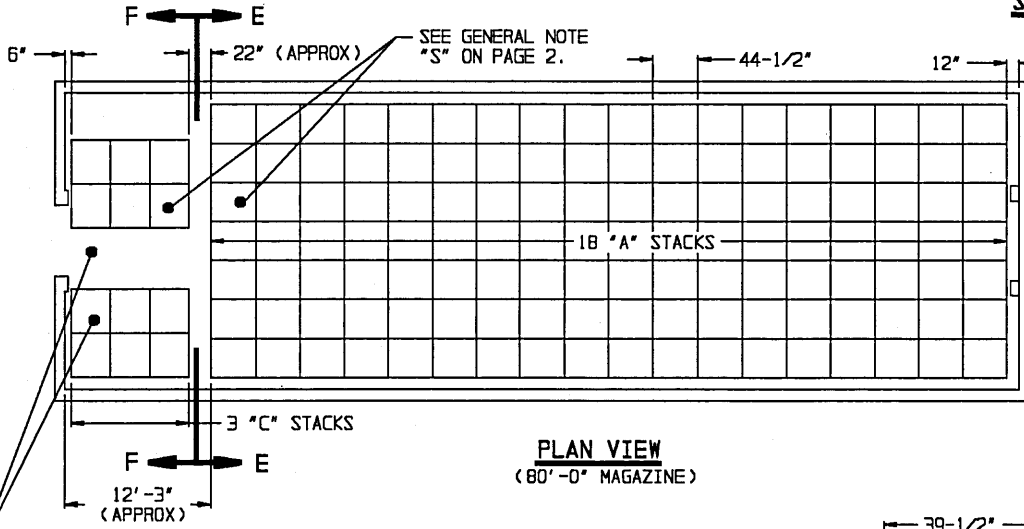

ITEM	QUANTITY
PALLET UNITS - - - -	234
PA116 CONTAINERS - - -	7,020

PLAN VIEW
(80'-0" MAGAZINE)

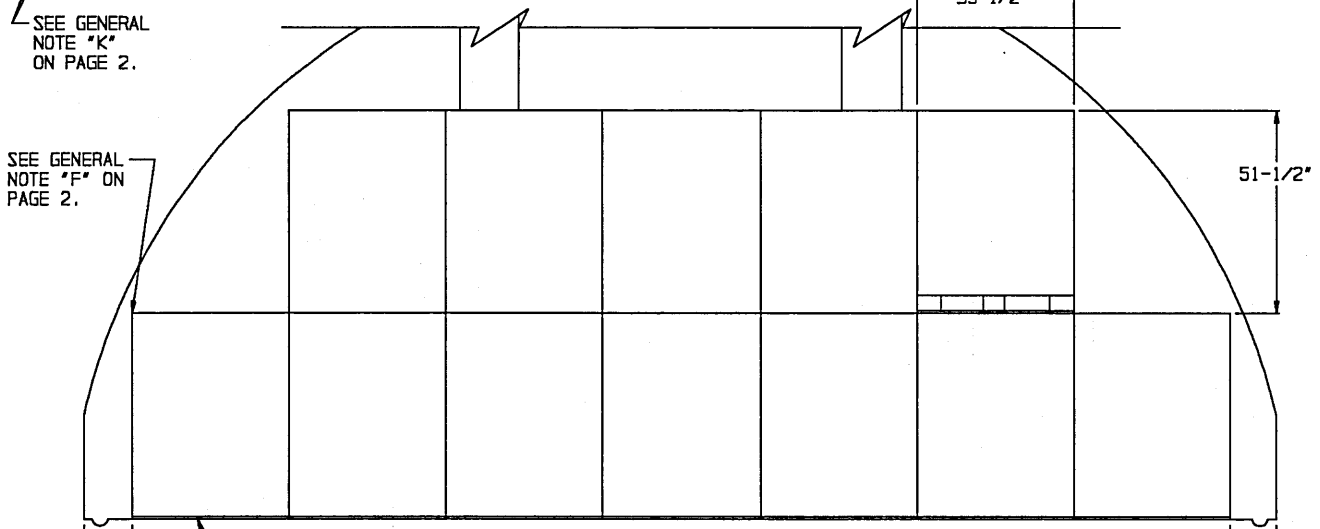

FLOOR DUNNAGE,
1" X 6" X 39-1/2"
(21 REOD PER STACK).

SECTION E-E
("A" STACK, 12 PALLET UNITS)

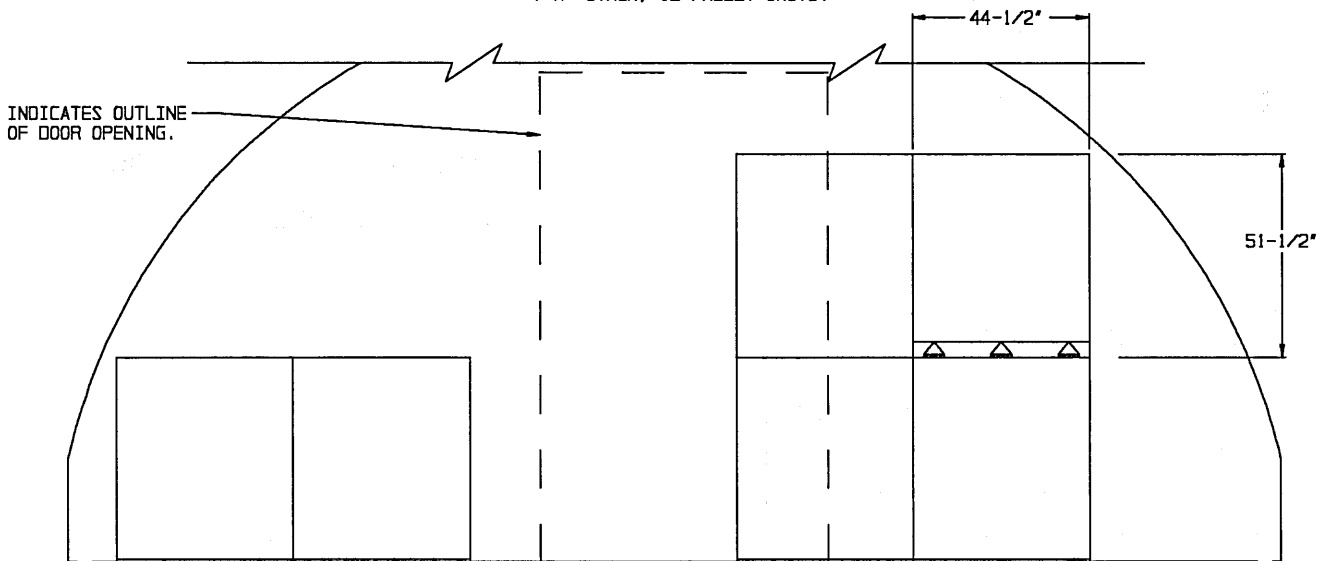

FLOOR DUNNAGE,
1" X 6" X 44-1/2"
(12 REOD PER STACK).

SECTION F-F
("C" STACK, 6 PALLET UNITS)

STORAGE IN 40'-0" MAGAZINE

(12'-1-3/4" HIGH)

ITEM	QUANTITY
PALLET UNITS - - - - -	102
PA116 CONTAINERS - - - - -	3,060

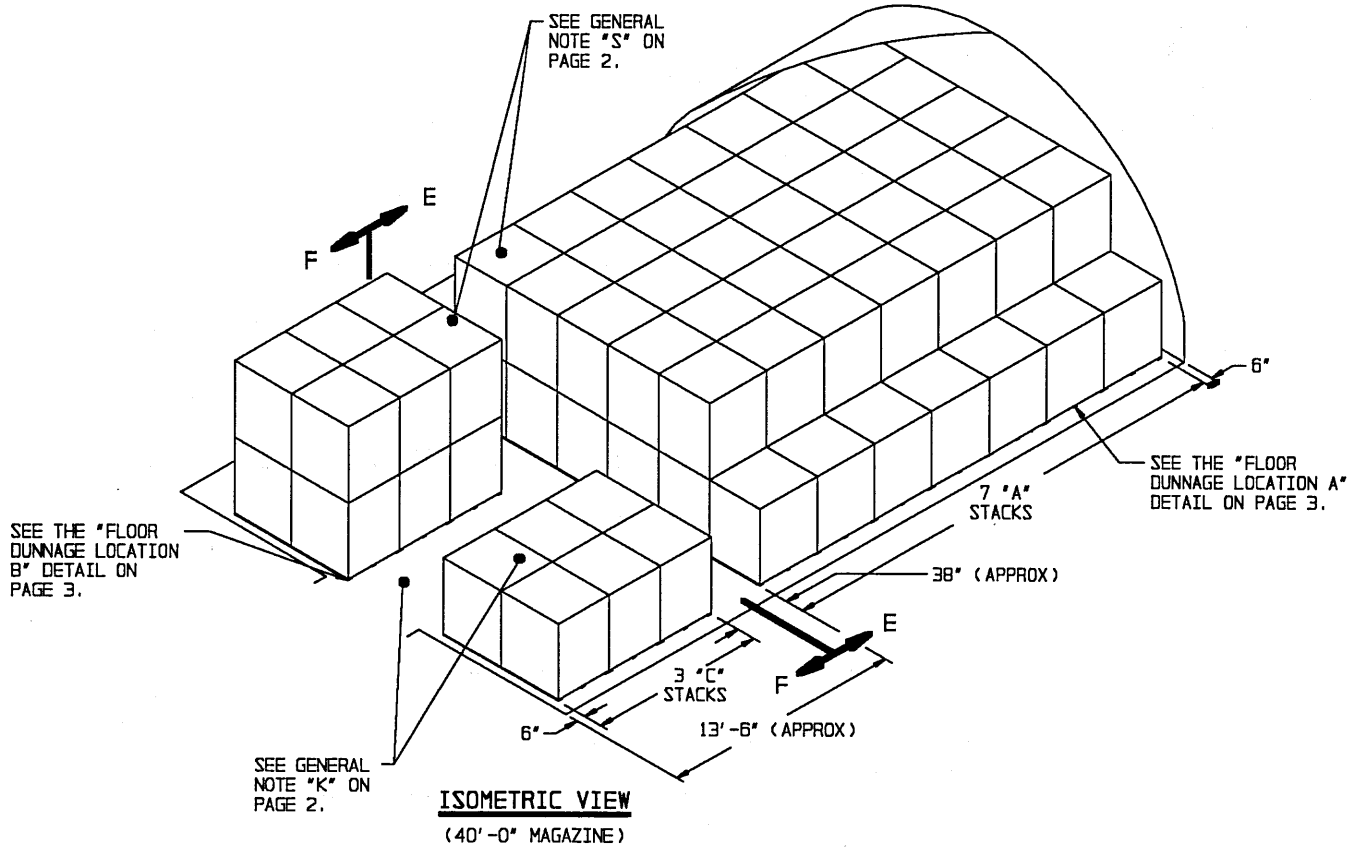

FOR "GENERAL NOTES", AND "MATERIAL SPECIFICATION" SEE PAGE 2.

BILL OF MATERIAL (PER STACK) *		
TYPE STACK	1" X 6" DUNNAGE LUMBER	
	LINEAR FEET	BOARD FEET
A	70	35
C	45	23

* SEE GENERAL NOTE "L" ON PAGE 2.

STORAGE IN 80'-0" MAGAZINE
(11'-0" HIGH)

ITEM	QUANTITY
PALLET UNITS - - - -	195
PA116 CONTAINERS - - -	5,850

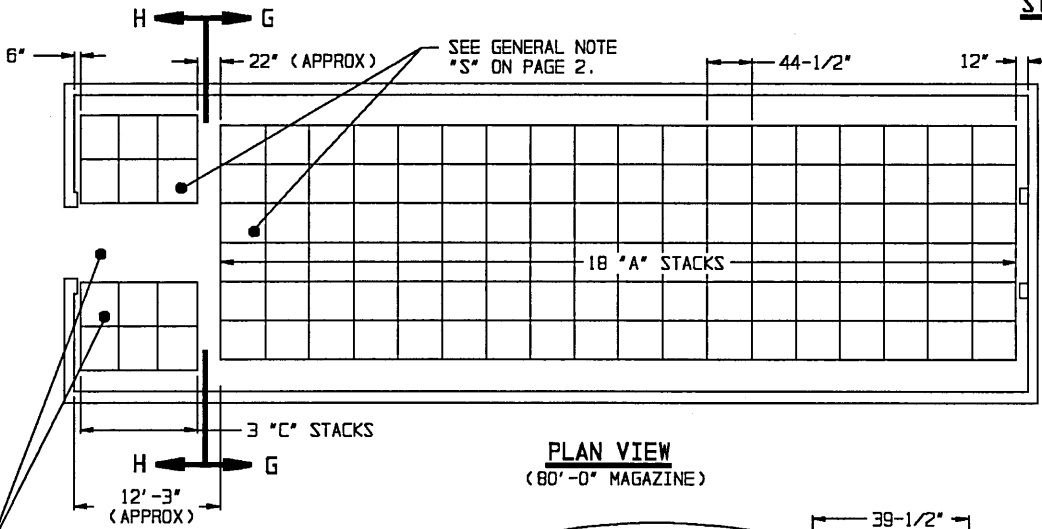

PLAN VIEW
(80'-0" MAGAZINE)

SEE GENERAL NOTE "K" ON PAGE 2.

SEE GENERAL NOTE "F" ON PAGE 2.

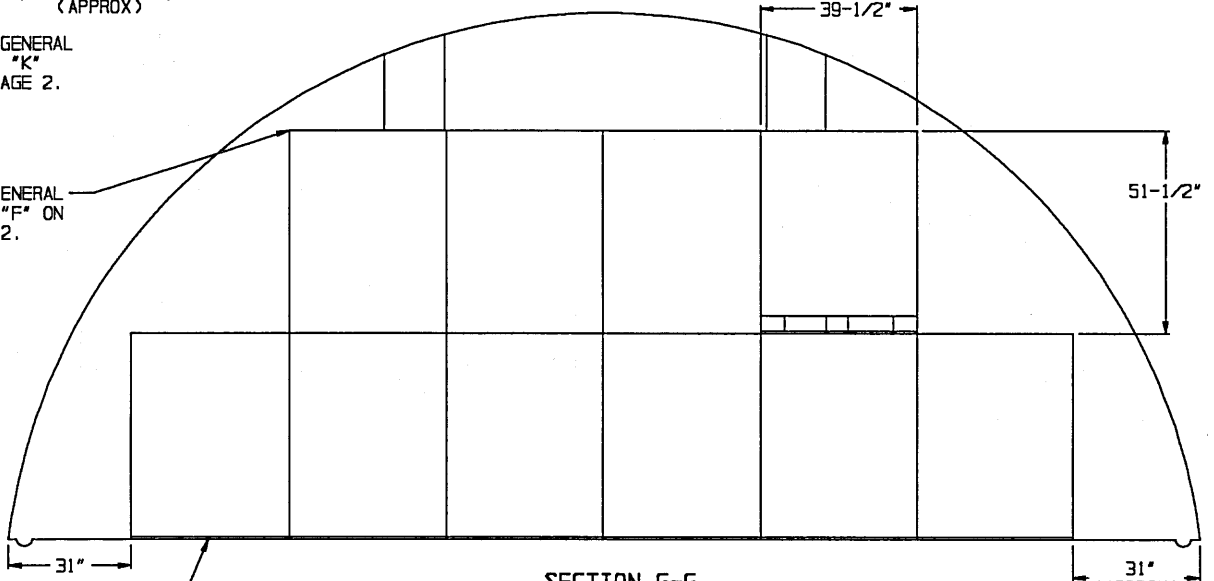

SECTION G-G
(*A* STACK, 10 PALLET UNITS)

FLOOR DUNNAGE,
1" X 6" X 39-1/2"
(18 REOD PER STACK).

INDICATES OUTLINE OF DOOR OPENING.

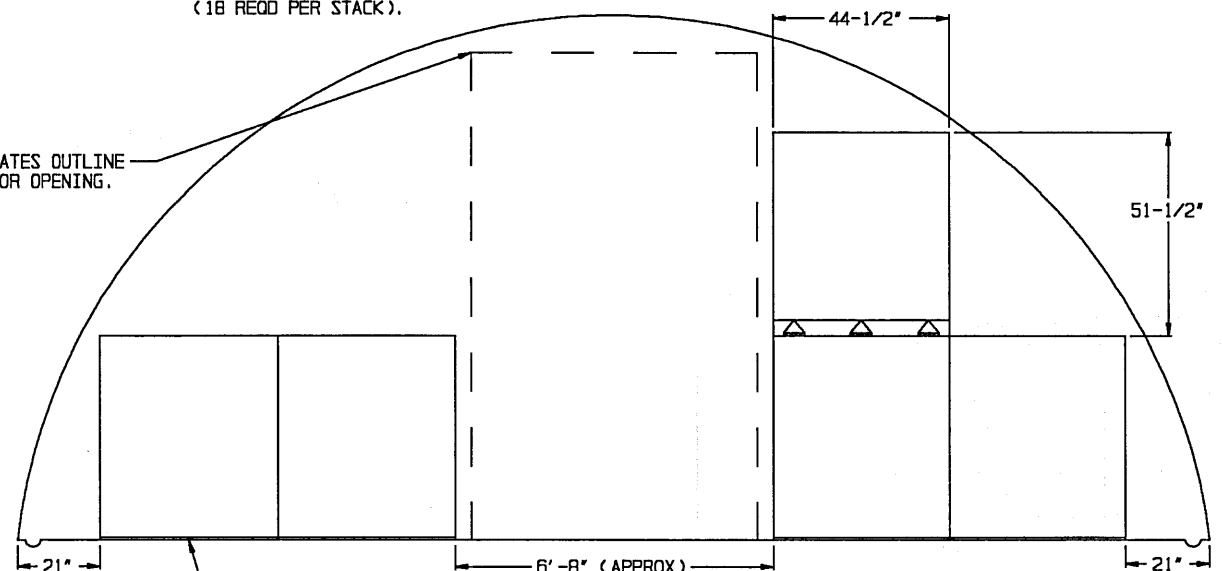

SECTION H-H
(*C* STACK, 5 PALLET UNITS)

FLOOR DUNNAGE,
1" X 6" X 44-1/2"
(12 REOD PER STACK).

STORAGE IN 40'-0" MAGAZINE

(11'-0" HIGH)

ITEM	QUANTITY
PALLET UNITS - - - - -	85
PA116 CONTAINERS - - - - -	2,550

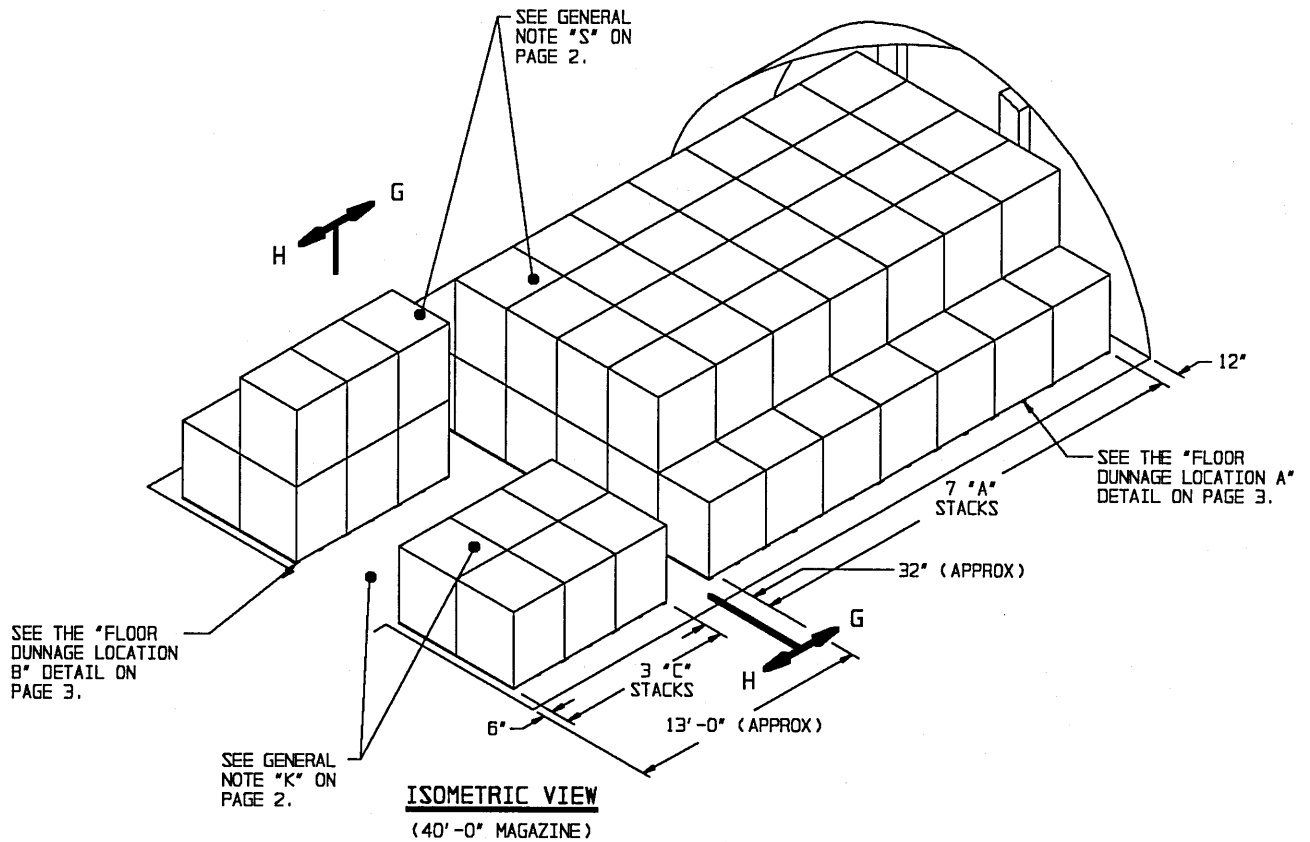

FOR "GENERAL NOTES", AND "MATERIAL SPECIFICATION" SEE PAGE 2.

BILL OF MATERIAL (PER STACK) *		
TYPE STACK	1" X 6" DUNNAGE LUMBER	
	LINEAR FEET	BOARD FEET
A	60	30
C	45	23

* SEE GENERAL NOTE "L" ON PAGE 2.

STORAGE IN 80'-0" MAGAZINE
(10'-0" HIGH)

ITEM	QUANTITY
PALLET UNITS - - - -	156
PA116 CONTAINERS - - -	4,680

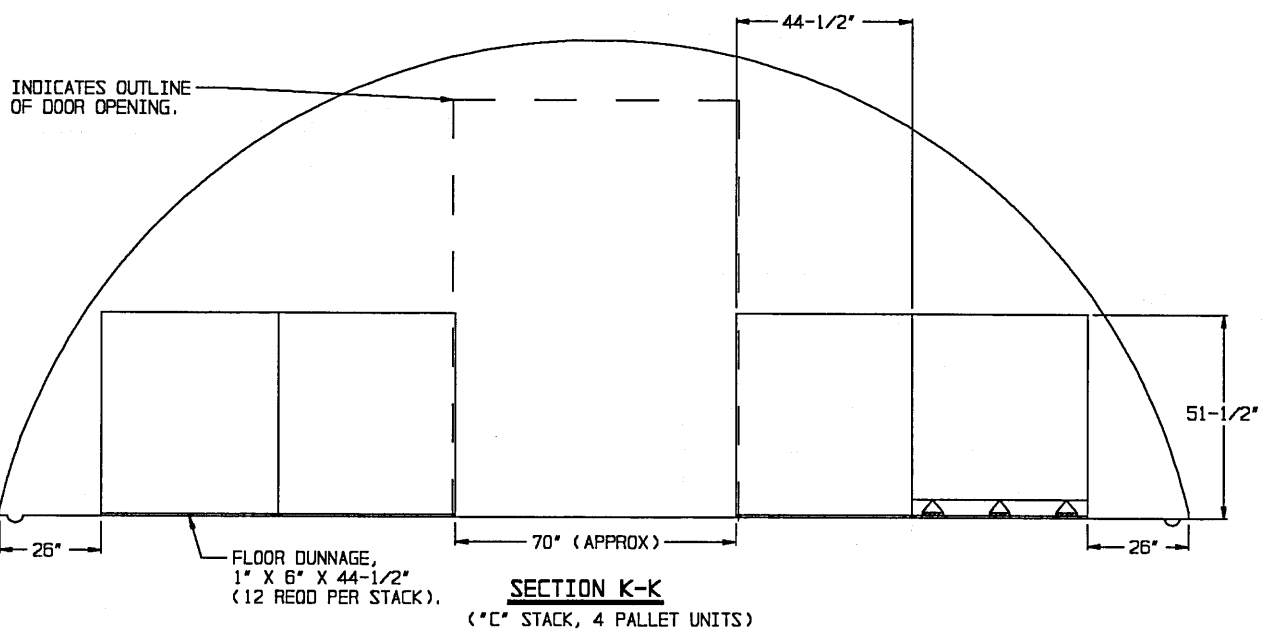
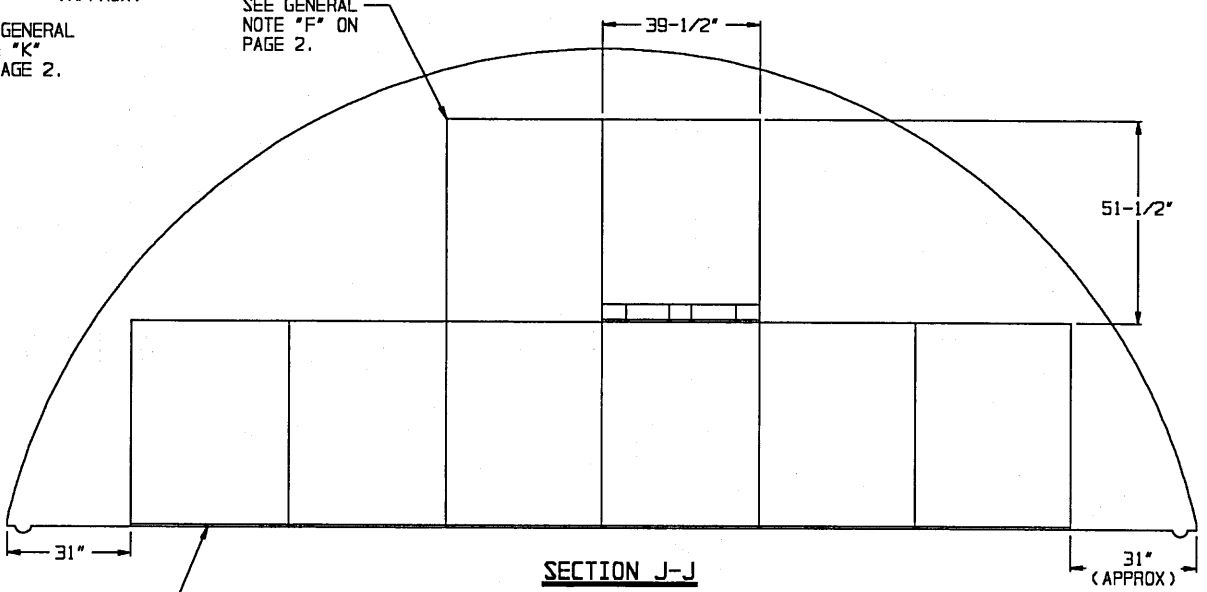
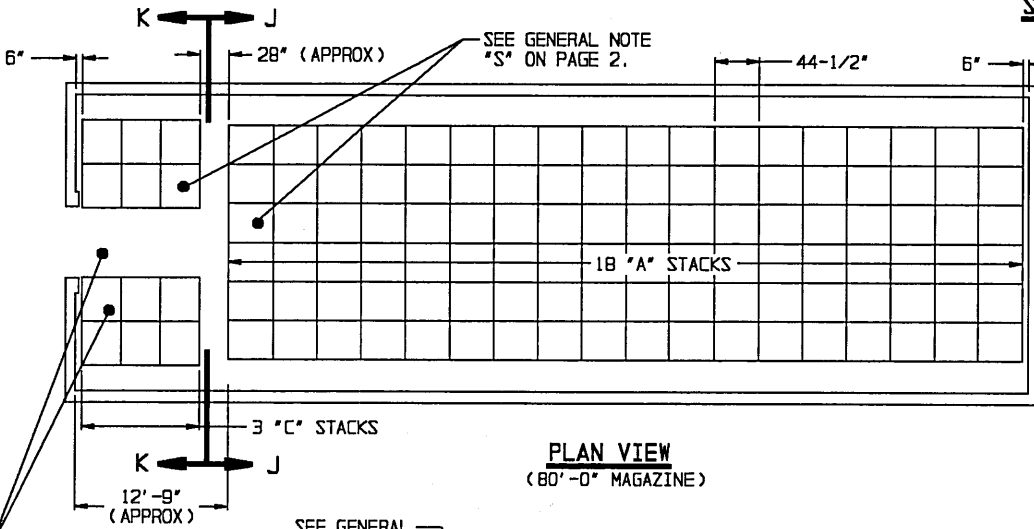

STORAGE IN 40'-0" MAGAZINE

(10'-0" HIGH)

ITEM	QUANTITY
PALLET UNITS - - - - -	68
PA116 CONTAINERS - - - - -	2,040

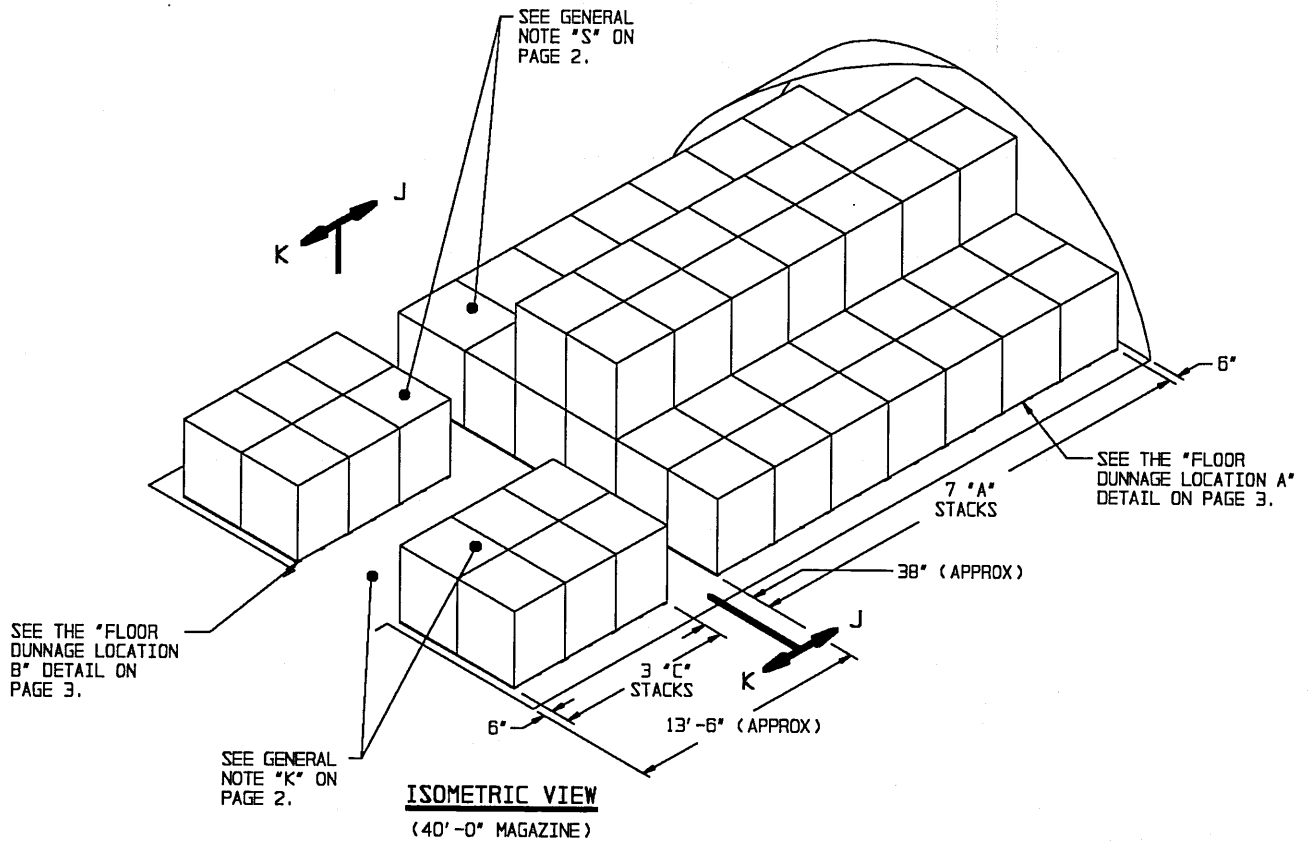

FOR "GENERAL NOTES", AND "MATERIAL SPECIFICATION" SEE PAGE 2.

BILL OF MATERIAL (PER STACK) *		
TYPE STACK	1" X 6" DUNNAGE LUMBER	
	LINEAR FEET	BOARD FEET
A	60	30
C	45	23

* SEE GENERAL NOTE "L" ON PAGE 2.

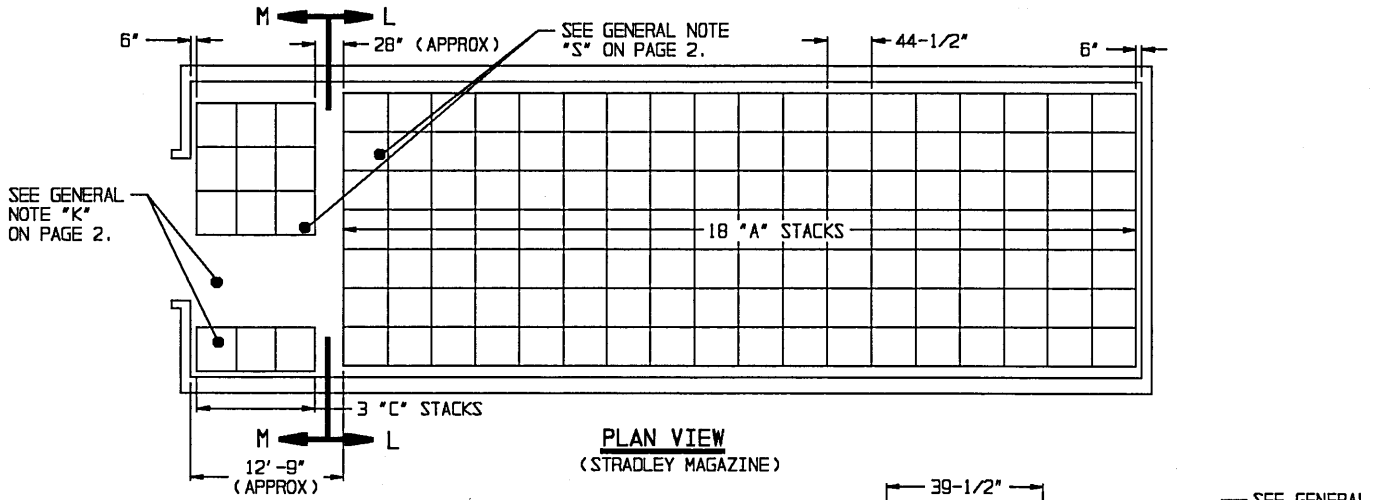

PLAN VIEW
(STRADLEY MAGAZINE)

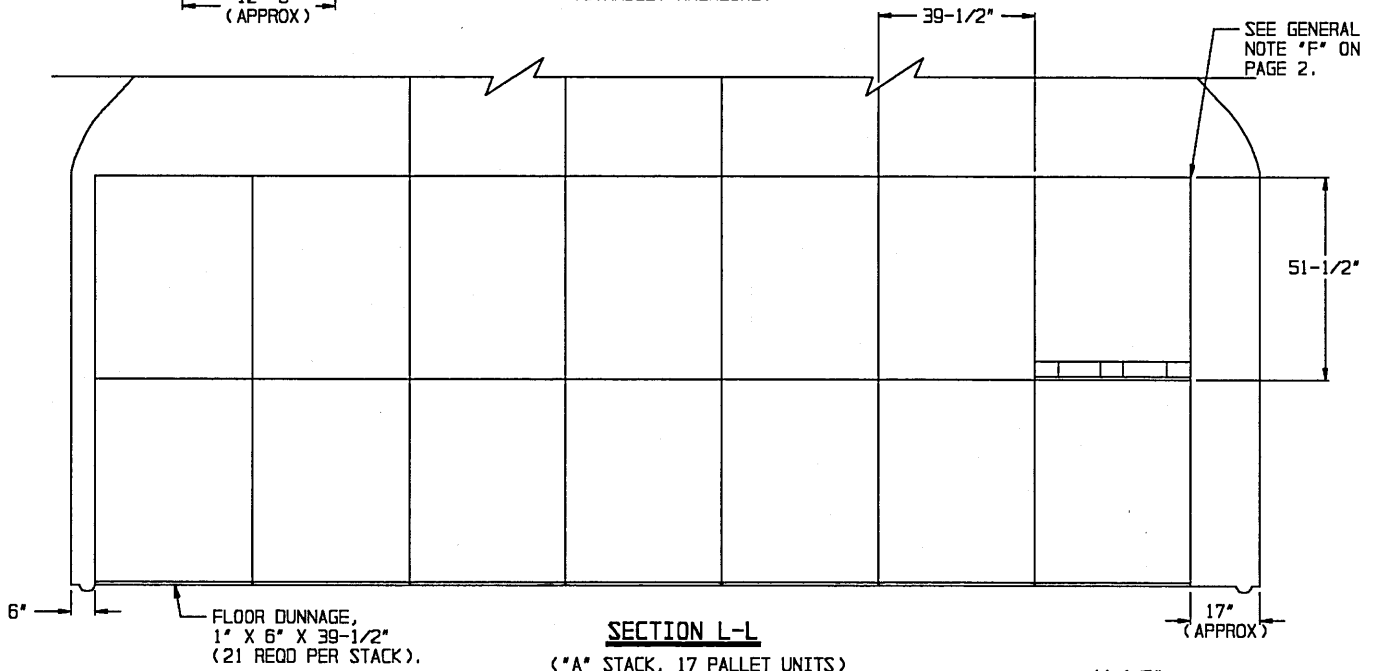

SECTION L-L
(*A* STACK, 17 PALLET UNITS)

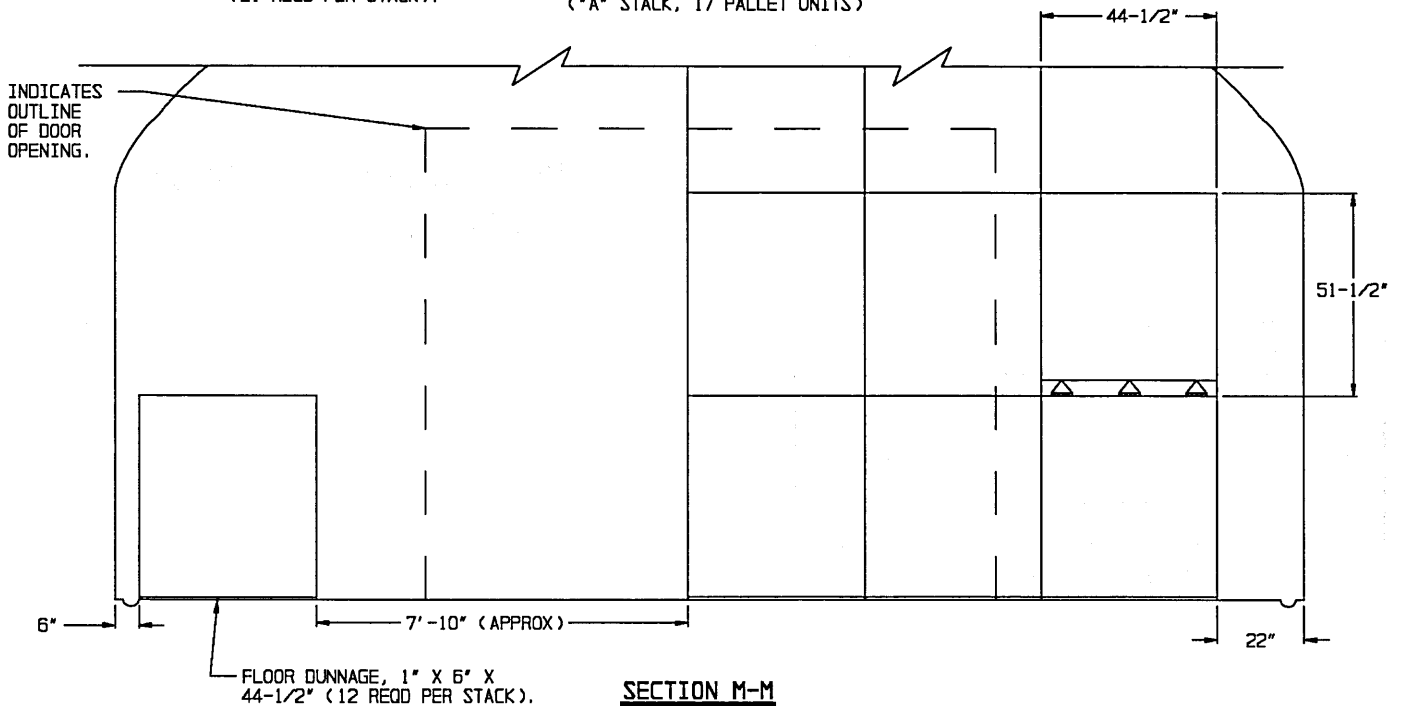

SECTION M-M
(*C* STACK, 9 PALLET UNITS)

STORAGE IN STRADLEY MAGAZINE

(14'-0" HIGH)

ITEM	QUANTITY
PALLET UNITS - - - - -	333
PA116 CONTAINERS - - - - -	9,990

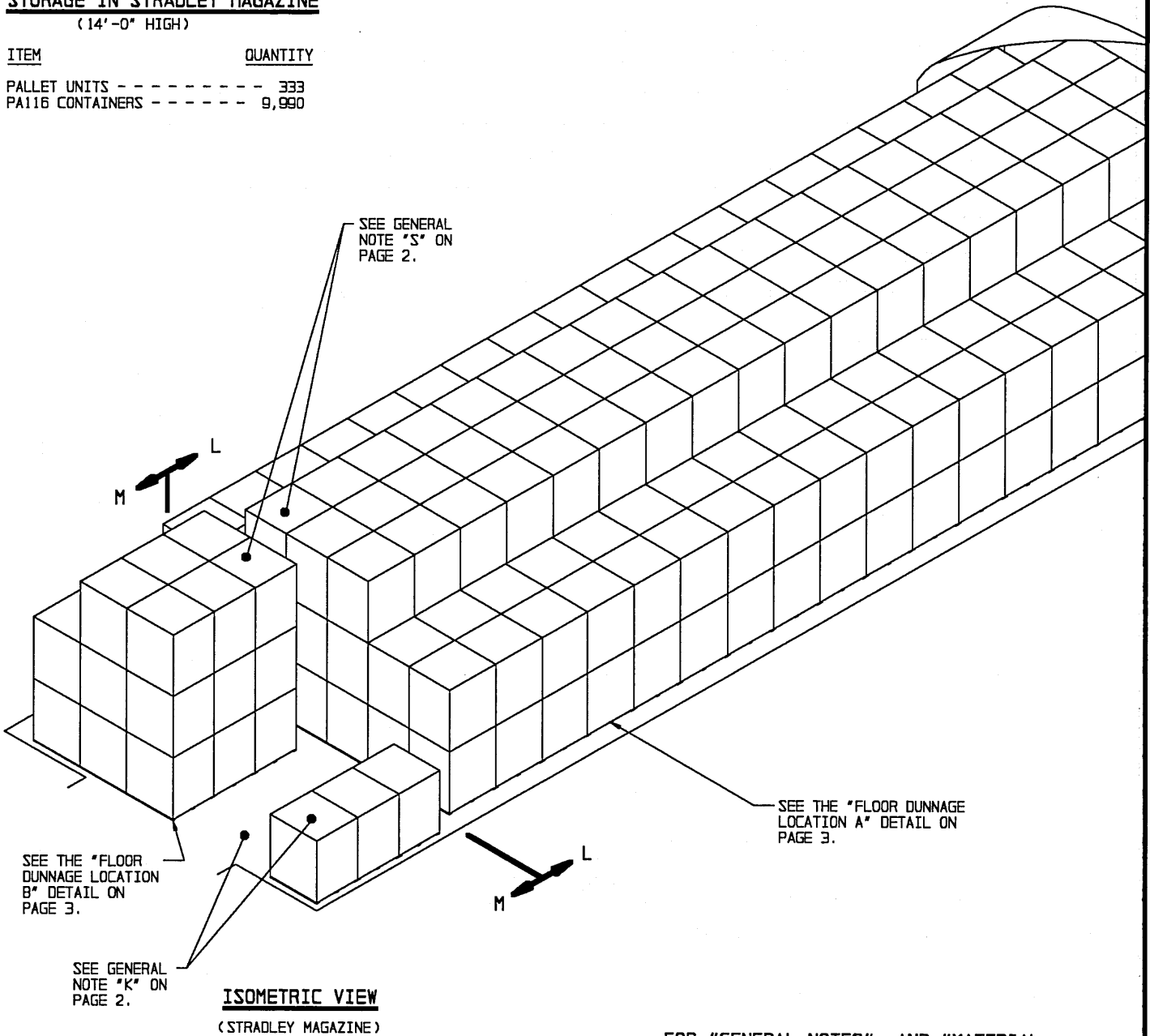

ISOMETRIC VIEW
(STRADLEY MAGAZINE)

FOR "GENERAL NOTES", AND "MATERIAL SPECIFICATION" SEE PAGE 2.

BILL OF MATERIAL (PER STACK) *		
TYPE STACK	1" X 6" DUNNAGE LUMBER	
	LINEAR FEET	BOARD FEET
A	70	35
C	45	23

* SEE GENERAL NOTE "L" ON PAGE 2.

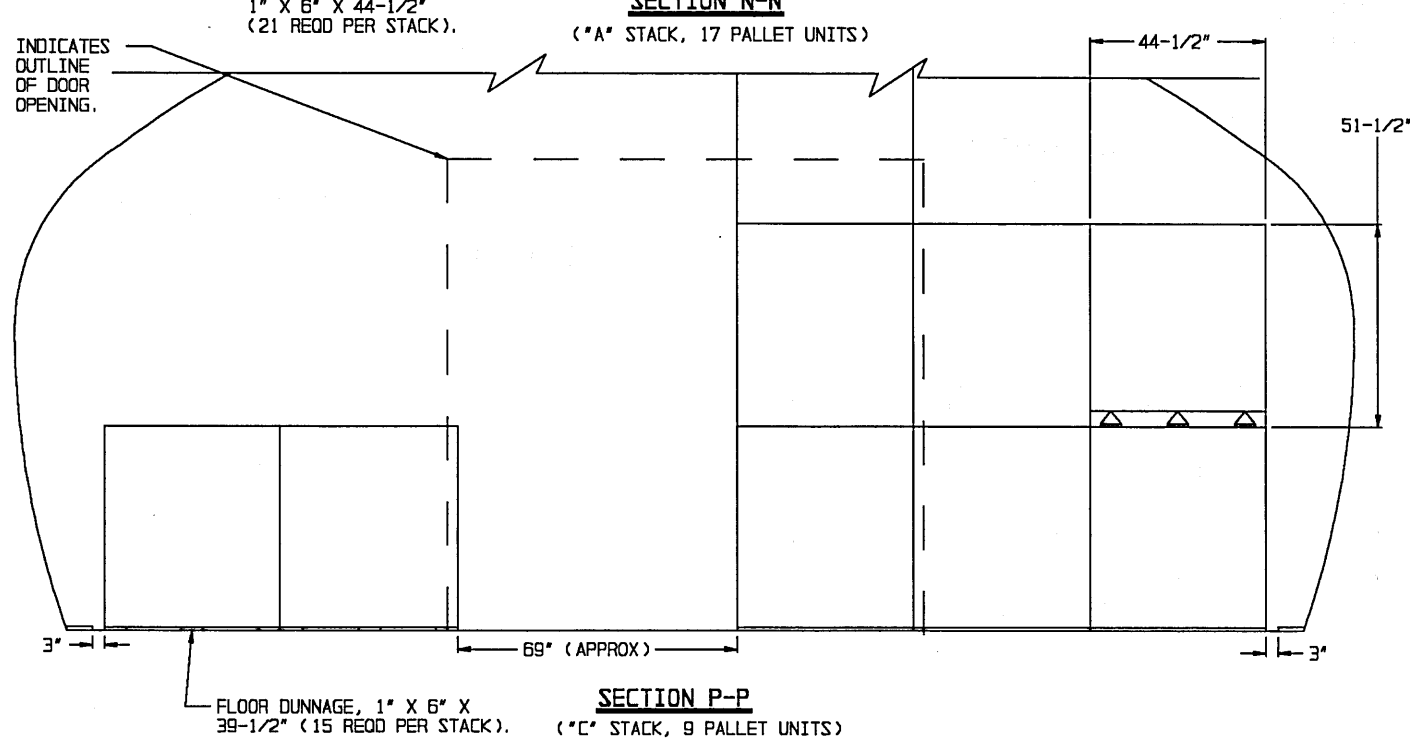
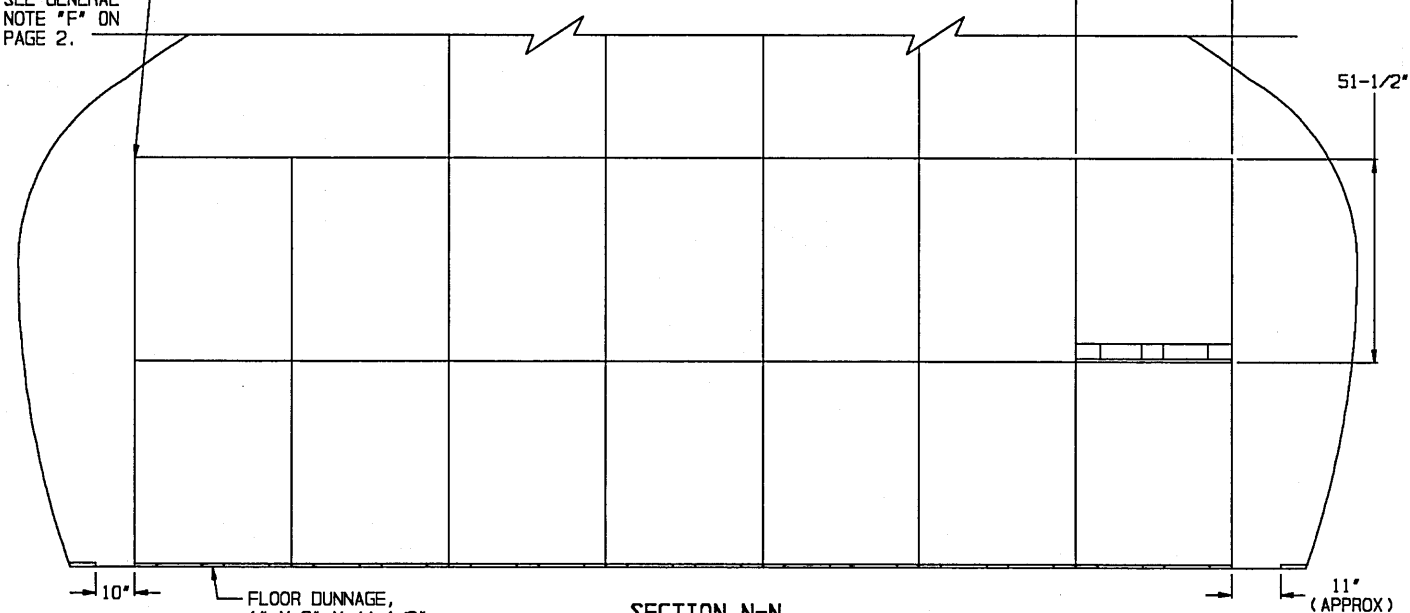
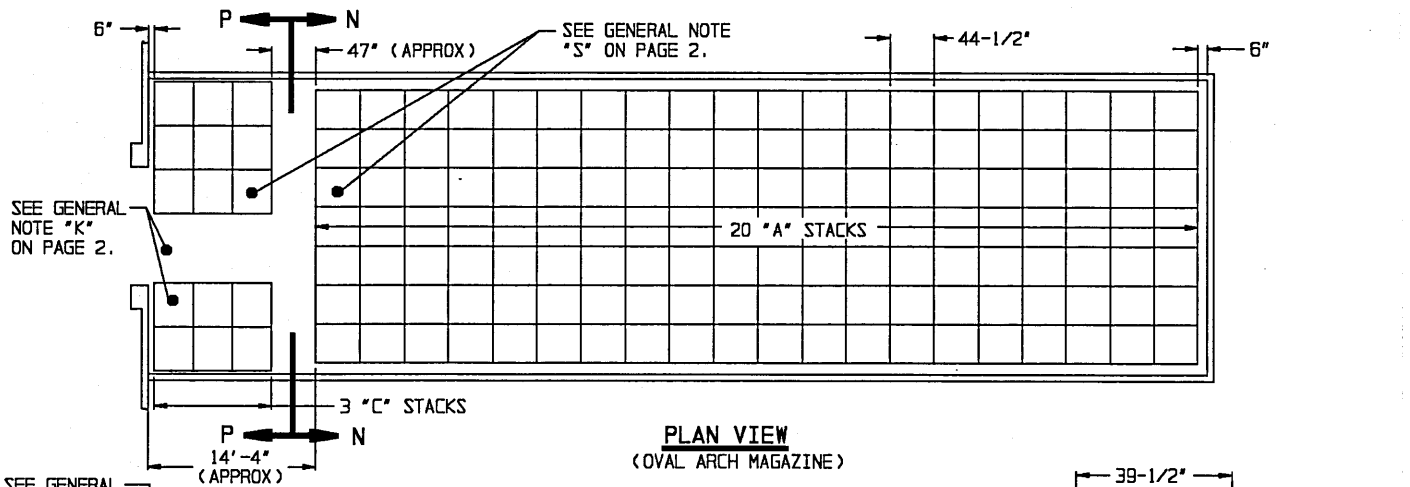

STORAGE IN OVAL ARCH MAGAZINE

(14'-4" HIGH)

ITEM	QUANTITY
PALLET UNITS - - - - -	367
PA116 CONTAINERS - - - - -	11,010

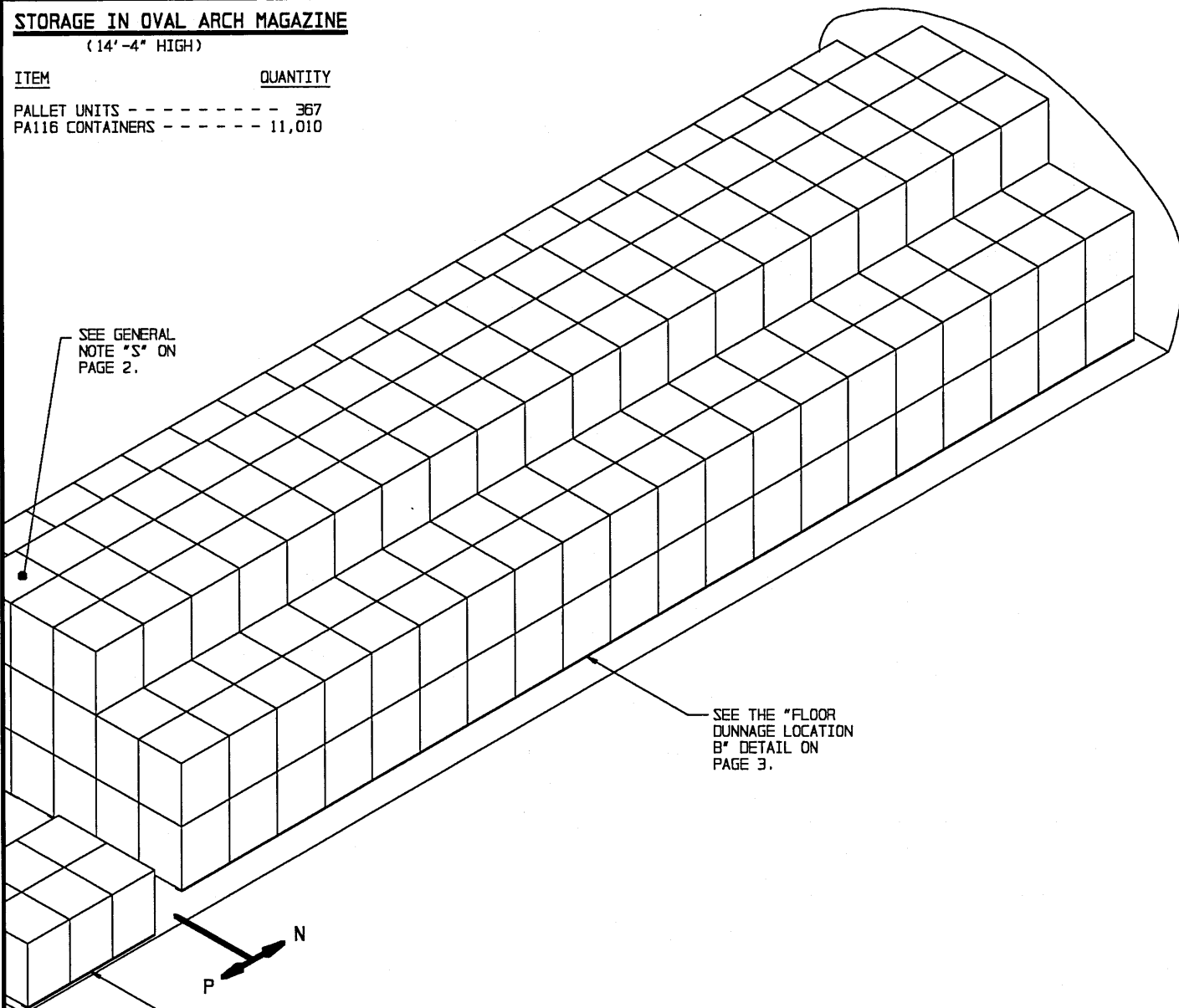

ISOMETRIC VIEW

(OVAL ARCH MAGAZINE)

SEE THE "FLOOR DUNNAGE LOCATION A" DETAIL ON PAGE 3.

SEE THE "FLOOR DUNNAGE LOCATION B" DETAIL ON PAGE 3.

FOR "GENERAL NOTES", AND "MATERIAL SPECIFICATION" SEE PAGE 2.

BILL OF MATERIAL (PER STACK) *		
TYPE STACK	1" X 6" DUNNAGE LUMBER	
	LINEAR FEET	BOARD FEET
A	78	39
C	50	25

* SEE GENERAL NOTE "L" ON PAGE 2.

STORAGE IN 52'-0" DIA MAGAZINE

ITEM	QUANTITY
PALLET UNITS - - - - -	232
PA116 CONTAINERS - - - - -	6,960

STORAGE IN 44'-7" DIA MAGAZINE

ITEM	QUANTITY
PALLET UNITS - - - - -	165
PA116 CONTAINERS - - - - -	4,950

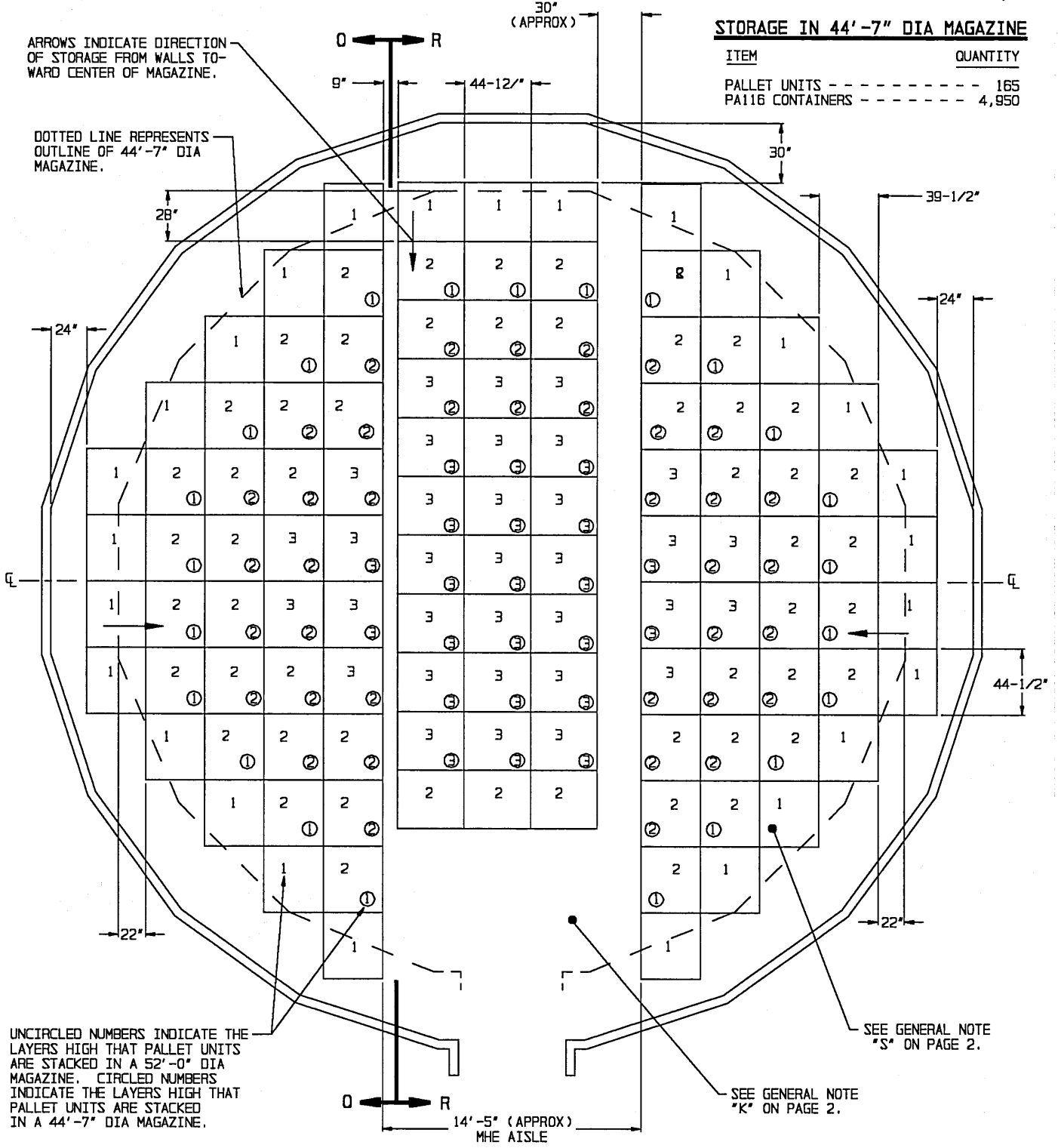

PLAN VIEW
(52'-0" DIA MAGAZINE)

SEE GENERAL NOTE "F" ON PAGE 2.

DOTTED LINE REPRESENTS
OUTLINE OF 44'-7" DIA
MAGAZINE.

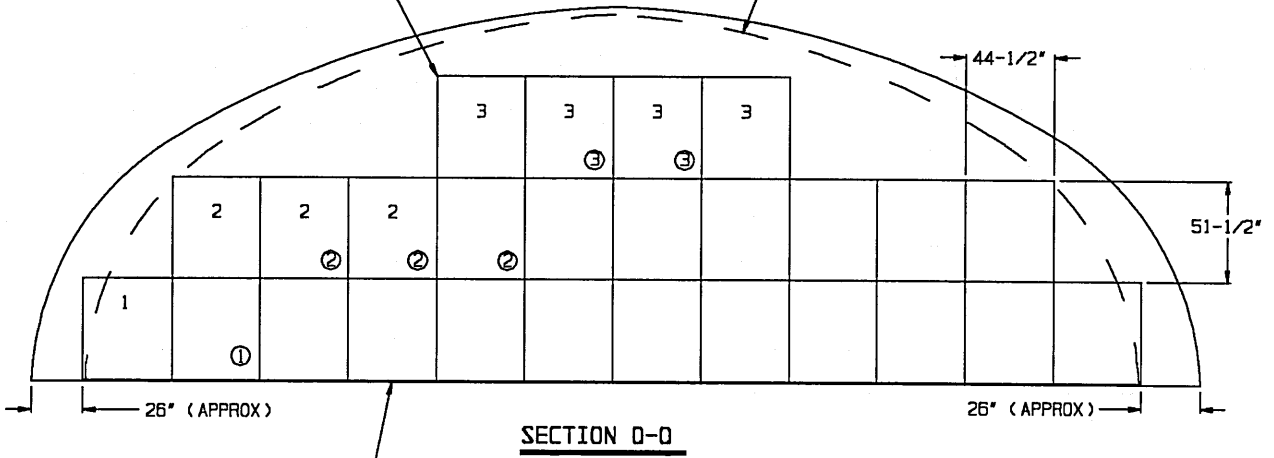

FLOOR DUNNAGE, 1" X 6"
X 39-1/2" (3 REQD PER
PALLET STACK). SEE THE
"FLOOR DUNNAGE LOCATION A"
DETAIL ON PAGE 3.

ONLY ONE OF THE ROWS OF PALLETS IS
SHOWN IN THIS SECTION. UNITS LOCA-
TED IN ADJACENT ROWS OR STACKS HAVE
BEEN OMITTED FOR CLARITY PURPOSES.

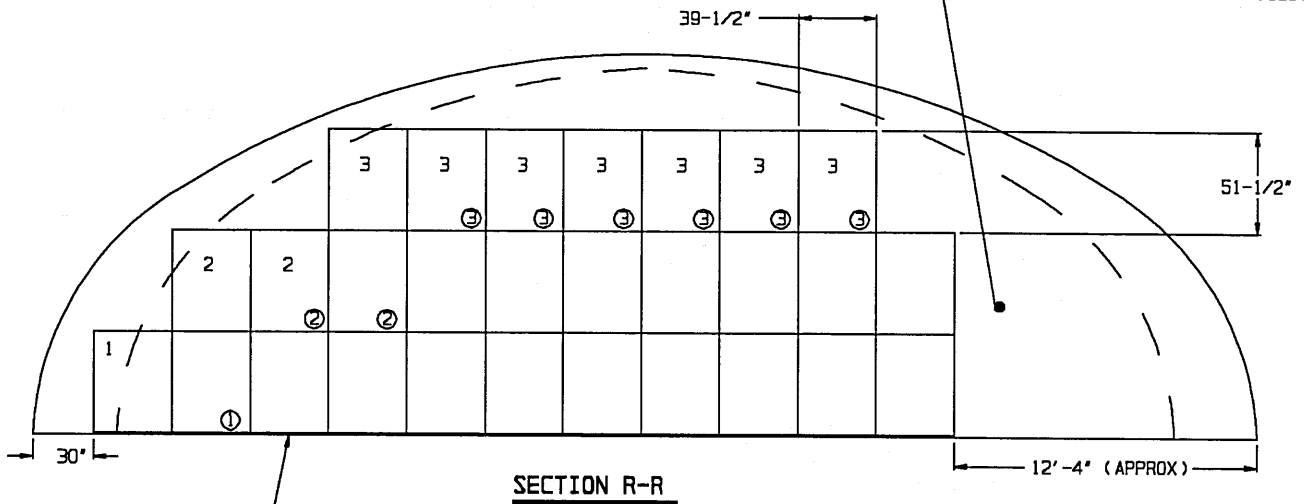

FLOOR DUNNAGE, 1" X 6"
X 39-1/2" (3 REQD PER
PALLET STACK). SEE THE
"FLOOR DUNNAGE LOCATION A"
DETAIL ON PAGE 3.

FOR "GENERAL NOTES", AND "MATERIAL
SPECIFICATION" SEE PAGE 2.

BILL OF MATERIAL (PER FIRST LAYER PALLET UNIT)*		
LUMBER	LINEAR FEET	BOARD FEET
1" X 6"	10	5

* SEE GENERAL NOTE "L" ON PAGE 2.

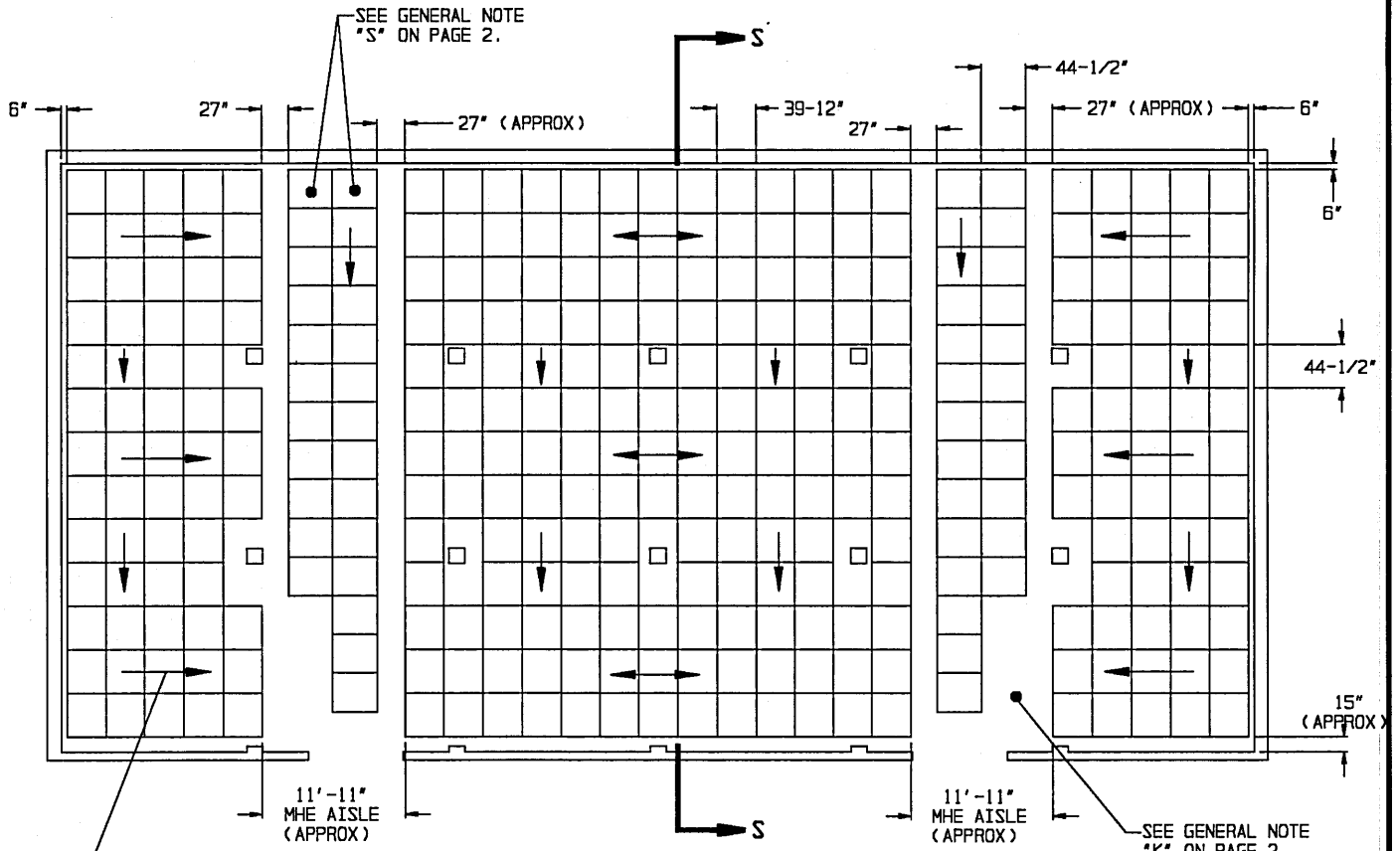

PLAN VIEW

(100'-8" L X 50'-0" W MAGAZINE)

ARROWS INDICATE DIRECTION OF STORAGE FROM WALLS TOWARD MHE AISLE.

PALLET UNITS IN TOP LAYER WILL BE OMITTED AS REQUIRED TO CLEAR ROOF SUPPORT CAPS AT TOP OF COLUMNS.

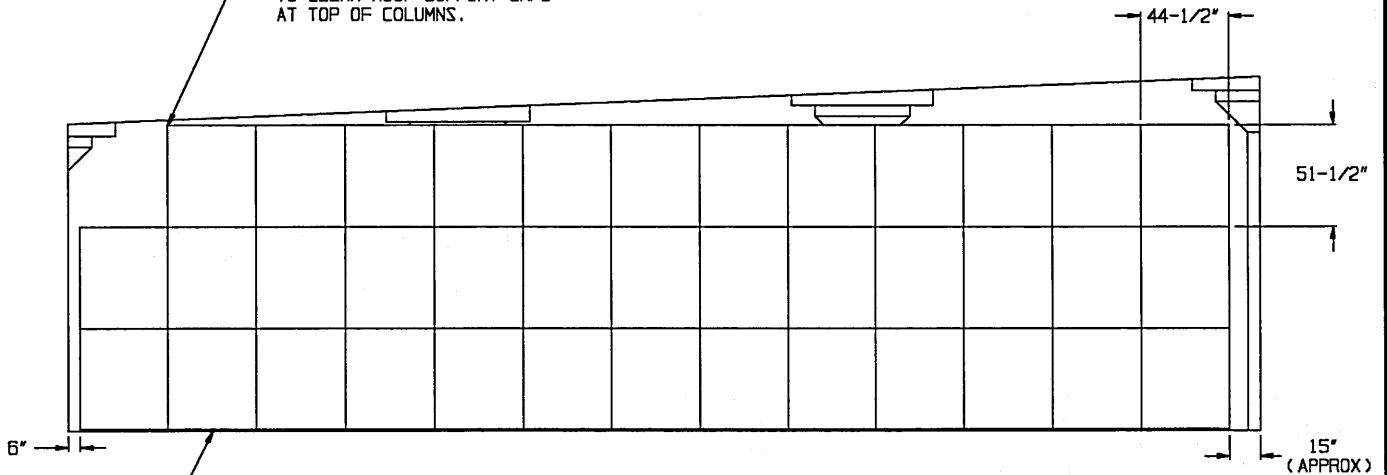

SECTION S-S

FLOOR DUNNAGE, 1' X 6' X 39-1/2" (3 REQD PER PALLET STACK). SEE THE "FLOOR DUNNAGE LOCATION A" DETAIL ON PAGE 3.

STORAGE IN 100'-8" X 50'-0" MAGAZINE

ITEM	QUANTITY
PALLET UNITS - - - - -	964
PA116 CONTAINERS - - - - -	28,920

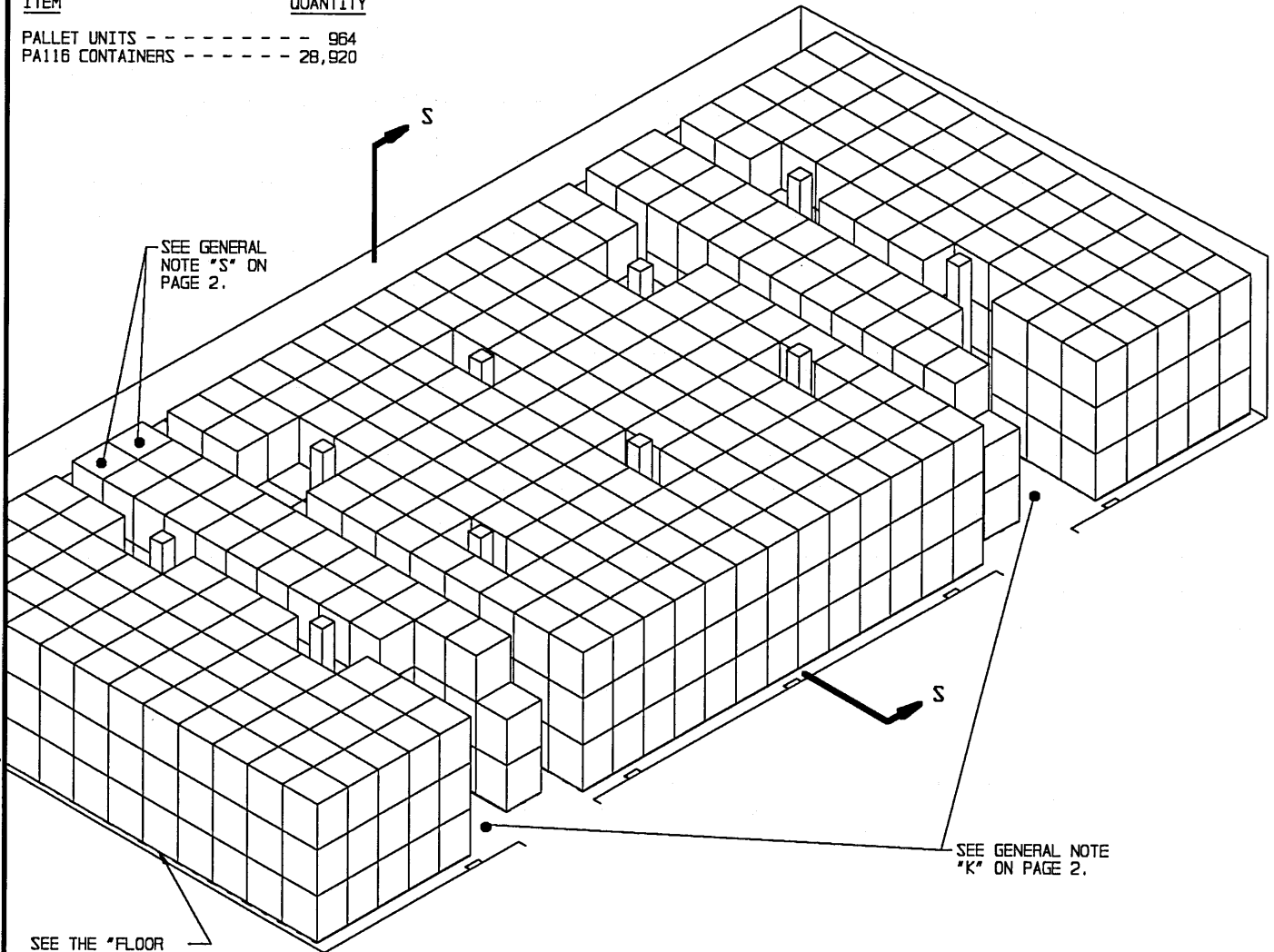

ISOMETRIC VIEW

(100'-8" L X 50'-0" W MAGAZINE)

FOR "GENERAL NOTES", AND "MATERIAL SPECIFICATION" SEE PAGE 2.

BILL OF MATERIAL (PER FIRST LAYER PALLET UNIT)*

LUMBER	LINEAR FEET	BOARD FEET
1" X 6"	10	5

* SEE GENERAL NOTE "L" ON PAGE 2.

SPECIAL NOTE:

- IF THE QUANTITY FOR A MAGAZINE IS TO BE REDUCED FROM WHAT IS SHOWN DUE TO THE PERMITTED "EXPLOSIVE LIMIT" OF FOR ANY OTHER REASON, SUCH AS A LIMITED QUANTITY TO BE STORED, THE DELINEATED PROCEDURES ARE TO BE ADJUSTED BY OMITTING STACKS RATHER THAN BY OMITTING LAYERS.

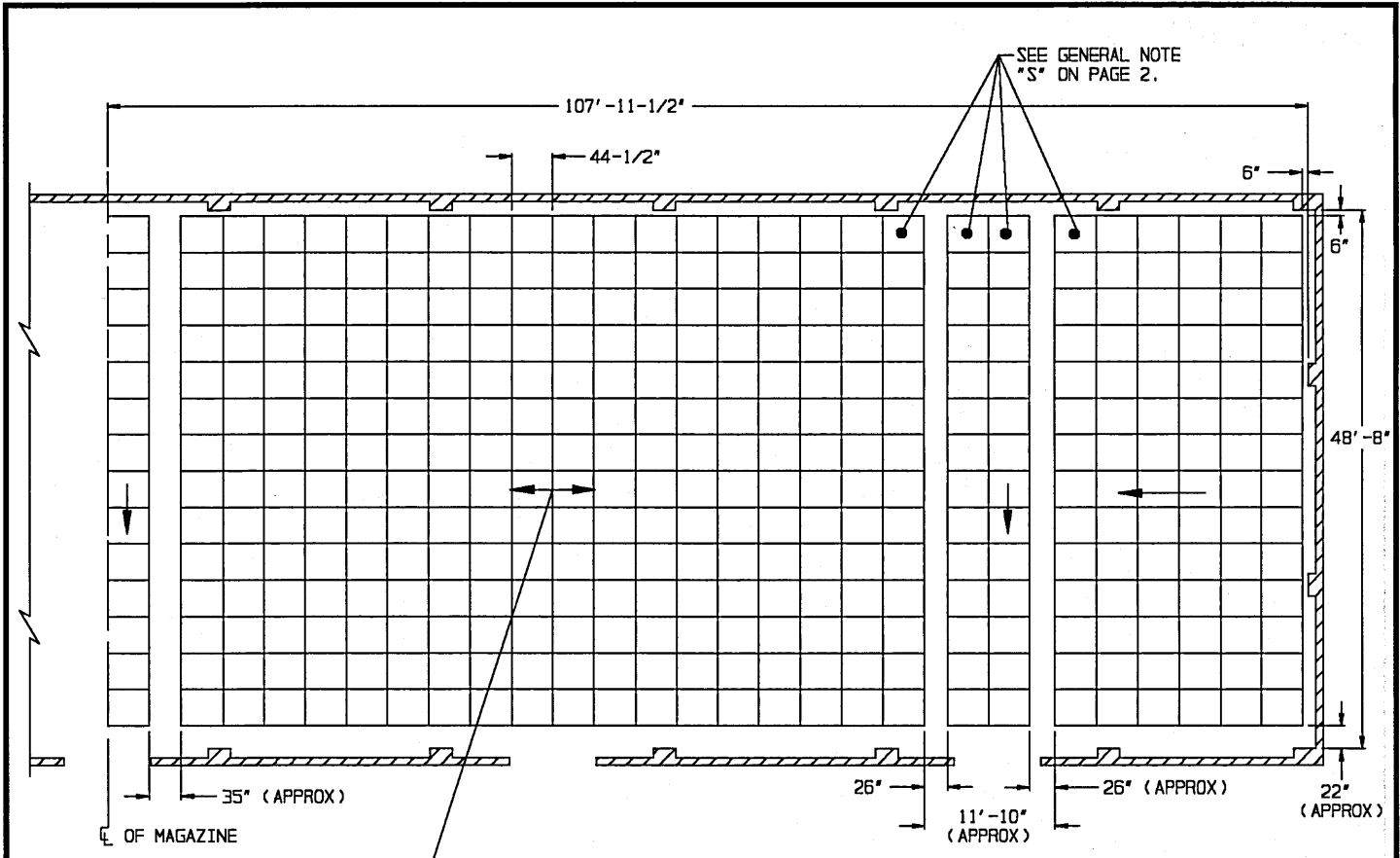

PLAN VIEW

ONE HALF OF A STANDARD MAGAZINE SHOWN.

STORAGE AS SHOWN

ONE HALF OF A STANDARD MAGAZINE.

ITEM	QUANTITY
PALLET UNITS - - - - -	1,099
PA116 CONTAINERS - - - - -	32,970

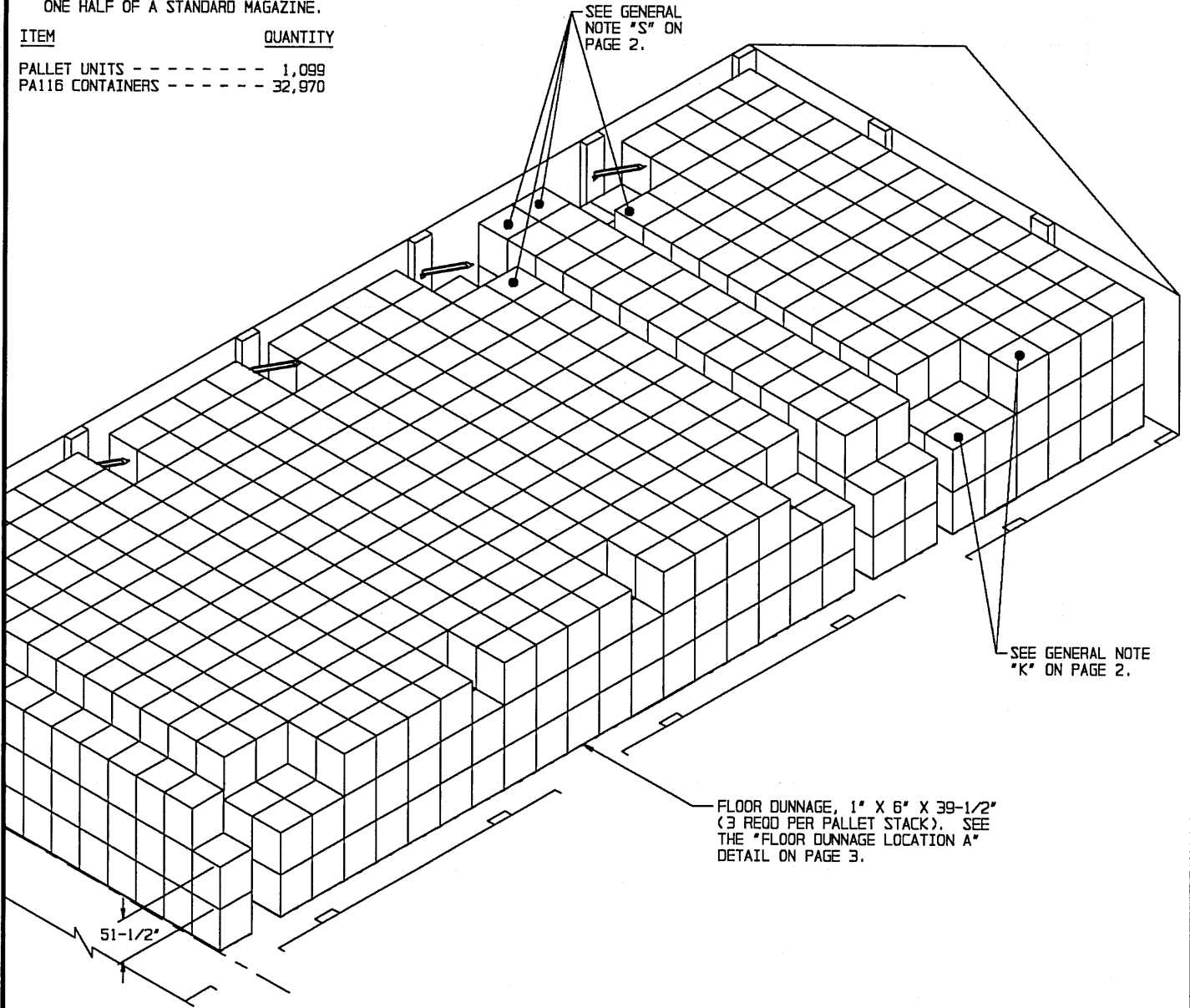

ISOMETRIC VIEW

(ONE-HALF OF A STANDARD MAGAZINE SHOWN)

FOR "GENERAL NOTES", AND "MATERIAL SPECIFICATION" SEE PAGE 2.

BILL OF MATERIAL (PER FIRST LAYER PALLET UNIT)*		
LUMBER	LINEAR FEET	BOARD FEET
1" X 6"	10	5

* SEE GENERAL NOTE "L" ON PAGE 2.

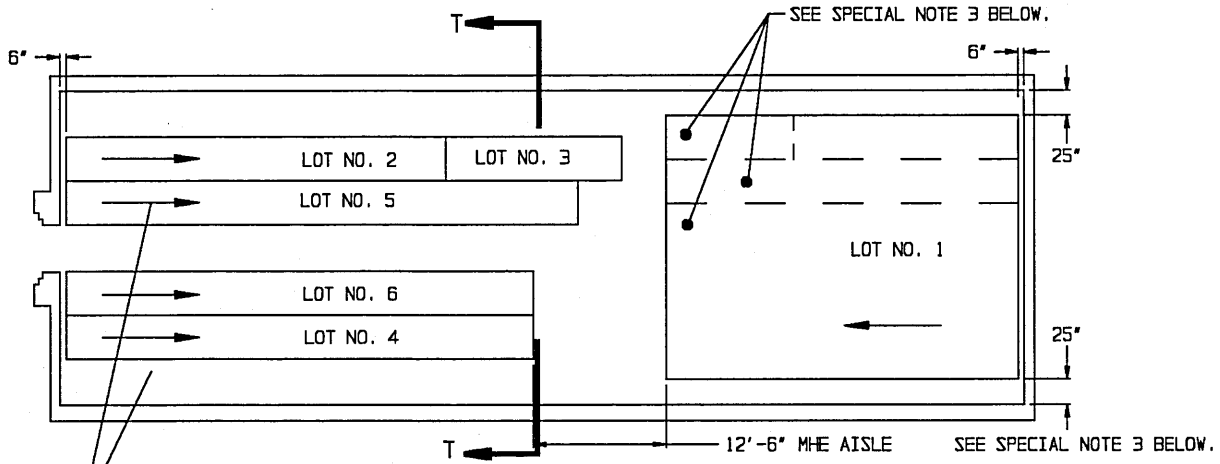

ARROWS INDICATE DIRECTION OF STORAGE FROM FRONT AND/OR REAR TOWARD CENTER OF THE LENGTH OF THE MAGAZINE.

PLAN VIEW
(81'-0" IGLOO MAGAZINE SHOWN)

INDICATES OUTLINE OF DOOR OPENING.

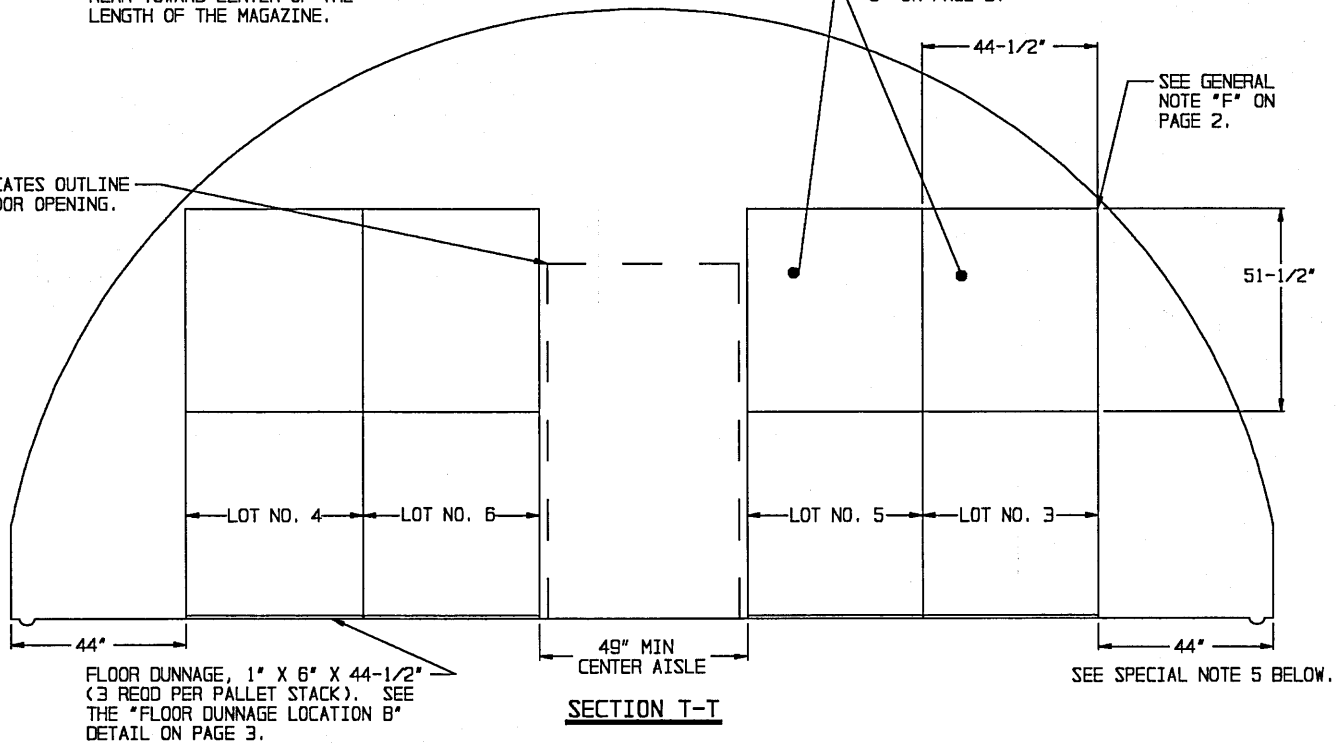

FLOOR DUNNAGE, 1" X 6" X 44-1/2"
(3 REOD PER PALLET STACK). SEE THE "FLOOR DUNNAGE LOCATION B" DETAIL ON PAGE 3.

SECTION T-T

SEE SPECIAL NOTE 5 BELOW.

SPECIAL NOTES:

1. THE STORAGE PLANS AND CONFIGURATIONS SHOWN ON THIS PAGE ARE TYPICAL ONLY AND APPLY TO RELATIVELY LARGE LOTS. ADAPTATIONS MAY BE MADE AS NUMBER AND SIZES OF LOTS TO BE STORED IN MAGAZINE REQUIRE.
2. AN INSPECTION/INVENTORY AISLE MUST BE PROVIDED AT ONE SIDE OR END OF EACH LOT.
3. GENERALLY, THE LARGEST LOT SHOULD BE STORED IN THE REAR OF THE MAGAZINE. HOWEVER, THE REAR AREA MAY BE USED TO STORE MORE THAN ONE LOT BY ERECTING ROWS SIMILAR TO THOSE SHOWN IN THE FRONTAL AREA. A CENTER AISLE WILL NOT BE REQUIRED IN THE REAR AREA AS LONG AS EACH LOT IS ACCESSIBLE FOR REMOVAL AND INSPECTION/INVENTORY IN ACCORDANCE WITH OTHER CRITERIA SPECIFIED IN THESE SPECIAL NOTES AND IN THE GENERAL NOTES ON PAGE 2.

(SPECIAL NOTES CONTINUED)

4. EACH LOT WITHIN THE MAGAZINE MUST BE ACCESSIBLE FOR MOVEMENT BY MHE. A SINGLE-LOT OF PALLET UNITS IS CONSIDERED "ACCESSIBLE" IF NO MORE THAN TWELVE (12) "LIFTS" OF ANOTHER LOT OR LOTS HAVE TO BE MADE TO GAIN ACCESS TO THAT LOT. A "LIFT" MAY CONSIST OF ONE (1) OR MORE PALLET UNITS, PROVIDING THE CAPACITY OF THE MHE PERMITS, AND SAFE HANDLING IS NOT JEOPARDIZED.
5. FOR STORAGE OF MULTIPLE-LOTS, THE DISTANCE FROM THE SIDE WALL WILL BE BASED ON THE OVERHEAD CLEARANCE REQUIRED FOR THE MHE.
6. WHEN TWO LOTS ARE STORED ADJACENT TO EACH OTHER, THEY SHOULD BE SEPARATED BY AT LEAST 1" TO PROVIDE CLEARANCE FOR REMOVAL OF EITHER LOT.

(CONTINUED AT RIGHT)

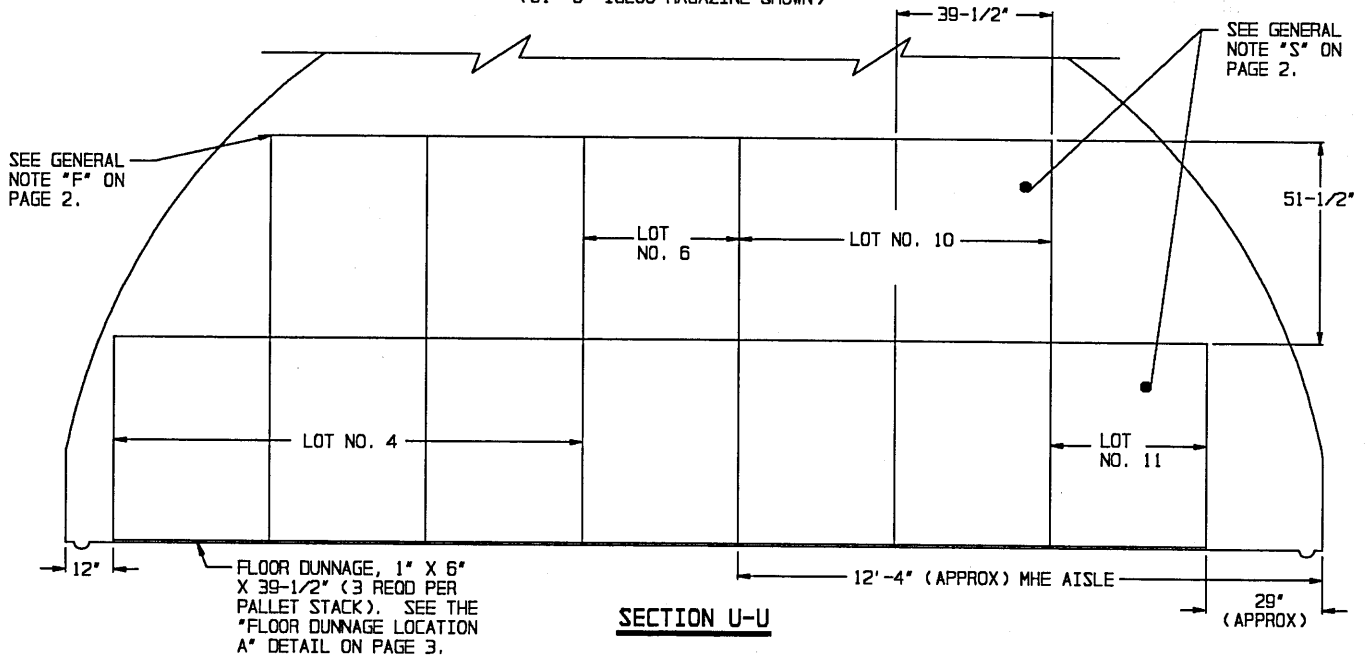
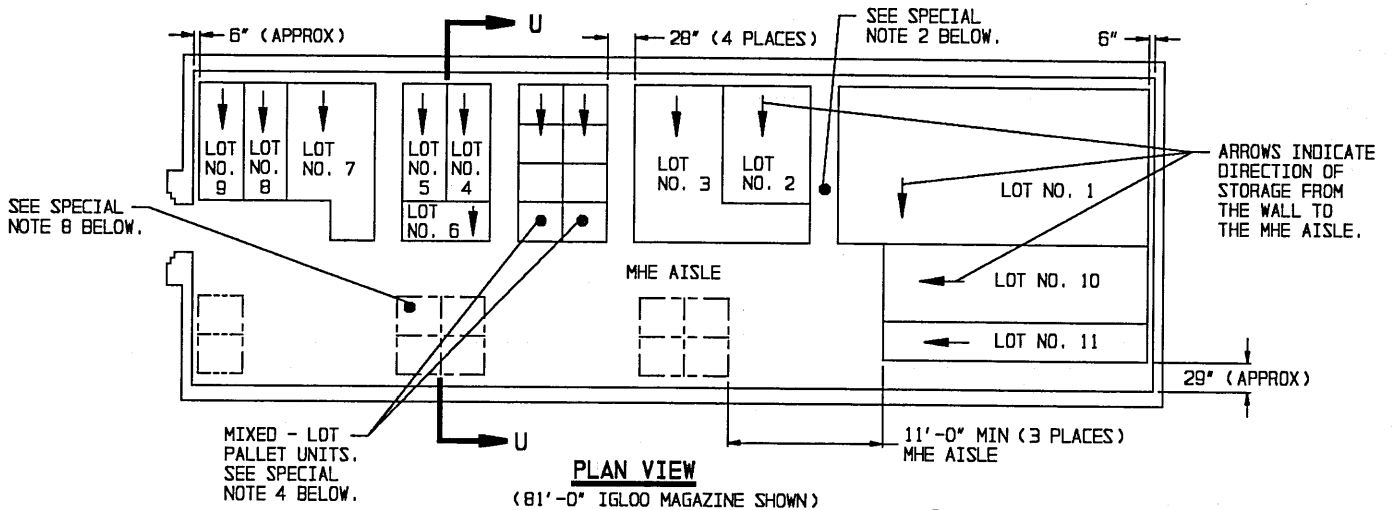

SPECIAL NOTES:

1. THE STORAGE PLANS AND CONFIGURATIONS SHOWN ON THIS PAGE ARE TYPICAL ONLY AND APPLY TO STORAGE OF NUMEROUS SMALL LOTS. ADAPTATIONS MAY BE MADE AS NUMBER AND SIZES OF LOTS TO BE STORED IN MAGAZINE REQUIRE.
2. AN INSPECTION/INVENTORY AISLE NOT LESS THAN 18" MUST BE PROVIDED AT ONE SIDE OF EACH "BURIED" LOT.
3. GENERALLY, THE LARGEST LOT SHOULD BE STORED IN THE REAR OF THE MAGAZINE. HOWEVER, THE REAR AREA MAY BE USED TO STORE MORE THAN ONE LOT BY ERECTING STACKS SIMILAR TO THOSE SHOWN IN THE FRONTAL AREA. AN MHE AISLE WILL BE REQUIRED ON ONE SIDE OF THE MAGAZINE, AND EACH LOT MUST BE ACCESSIBLE FOR REMOVAL AND INSPECTION/INVENTORY IN ACCORDANCE WITH OTHER CRITERIA SPECIFIED IN THESE SPECIAL NOTES AND IN THE GENERAL NOTES ON PAGE 2.
4. A MIXED-LOT PALLET UNIT MAY HAVE FORM TWO LOTS PER PALLET UNIT UPWARD TO AS MANY DIFFERENT LOTS AS COMPLETE ROUNDS WITHIN THAT UNIT. HOWEVER, ALL COMPLETE ROUNDS AND LOTS WITHIN THE PALLET UNIT MUST HAVE THE SAME NATIONAL STOCK NUMBER AND CONDITION CODE.
5. EACH LOT WITHIN THE MAGAZINE MUST BE ACCESSIBLE FOR MOVEMENT BY MHE. PALLET UNITS OF A SINGLE-LOT OR MIXED-LOT PALLET UNITS ARE CONSIDERED "ACCESSIBLE" IF NO MORE THAN TWELVE (12) "LIFTS" OF ANOTHER LOT OR LOTS HAVE TO BE MADE TO GAIN ACCESS TO THE SINGLE-LOT OR MIXED-LOT UNITS. A "LIFT" MAY CONSIST OF ONE (1) OR MORE PALLET UNITS, PROVIDING THE CAPACITY OF THE MHE PERMITS AND SAFE HANDLING IS NOT JEOPARDIZED.

(CONTINUED AT RIGHT)

(SPECIAL NOTES CONTINUED)

6. FOR STORAGE OF MULTIPLE LOTS, THE DISTANCE FROM THE SIDE-WALL WILL BE BASED ON THE OVERHEAD CLEARANCE REQUIRED FOR MHE.
7. WHEN TWO LOTS ARE STORED ADJACENT TO EACH OTHER, THEY SHOULD BE SEPARATED BY AT LEAST 1" TO PROVIDE CLEARANCE FOR REMOVABLE OF EITHER LOT.
8. AREAS INCLOSED BY DOTTED LINES INDICATE LOCATIONS WHERE ADDITIONAL LOTS MAY BE STORED OR WHERE ADDITIONAL ITEMS MAY BE STORED, THAT ARE FROM THE LOT OR LOTS WHICH ARE DIRECTLY OR ALMOST DIRECTLY ACROSS THE CENTER AISLE ON THE OTHER SIDE OF THE MAGAZINE. COMPLIANCE WITH ALL OF THE MULTIPLE-LOT CRITERIA AS SET FORTH ON THIS PAGE MUST BE OBSERVED. THE SIZE OF THE LOTS BEING STORED AND THE CRITERIA OF SPECIAL NOTE 5, RELATIVE TO "12" LIFTS" WILL BE MAJOR FACTORS IMPACTING ON THE NUMBER OF UNIT LOADS THAT CAN BE STORED IN AN "ADDITIONAL STORAGE LOCATION". MORE OR FEWER STACKS THAN SHOWN MAY BE STORED AT ANY ONE OF THE ADDITIONAL STORAGE LOCATIONS. AN 11-FOOT MHE OPERATING AREA HAS BEEN SPECIFIED FOR ACCESS TO EACH "ADDITIONAL LOCATION" BY FORKLIFT TRUCK. THIS OPERATING AREA IS BASED ON REQUIREMENTS OF FORKLIFT TRUCKS COMMONLY USED IN STORAGE MAGAZINES. THE MHE OPERATING AREA CAN BE ENLARGED AS REQUIRED TO SUIT AVAILABLE FORKLIFT TRUCKS, AND SHOULD BE MADE SMALLER IF AVAILABLE MHE PERMITS. A "CENTER AISLE" (SPACE BETWEEN STORAGE ON ONE SIDE OF A MAGAZINE AND AN "ADDITIONAL STORAGE LOCATION") IS TO BE AT LEAST 49 INCHES WIDE. AN AISLE SLIGHTLY WIDER THAN 49 INCHES WILL ENHANCE FORKLIFT TRUCK MOVEMENT WITHIN A MAGAZINE; HOWEVER, THIS AISLE SHOULD NOT BE MADE WIDER IF A LOSS IN STORAGE RESULTS.

TYPICAL MULTIPLE-LOT STORAGE IN IGLOO AND ARCH TYPE MAGAZINES

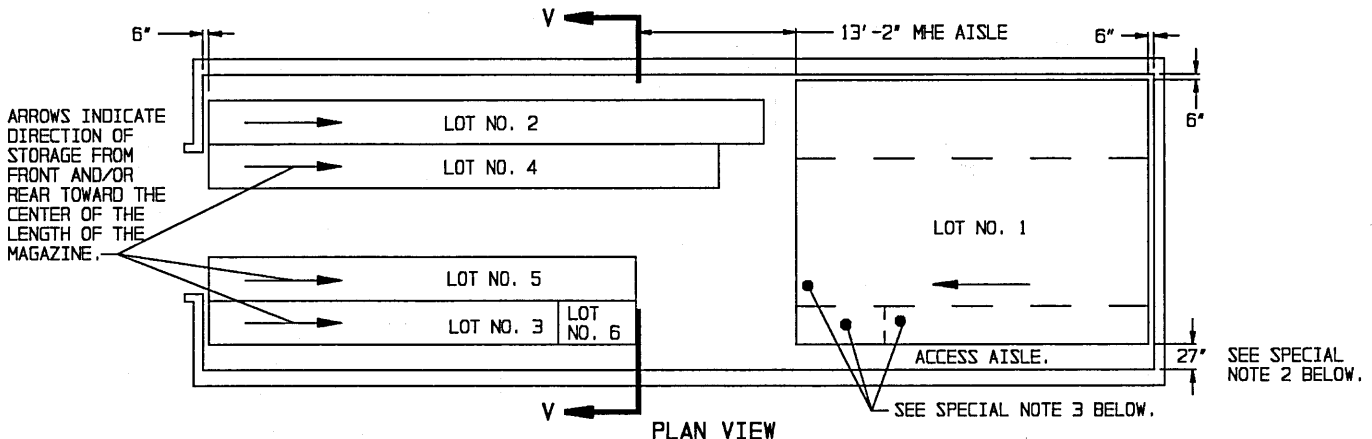

PLAN VIEW
(STRADLEY MAGAZINE)

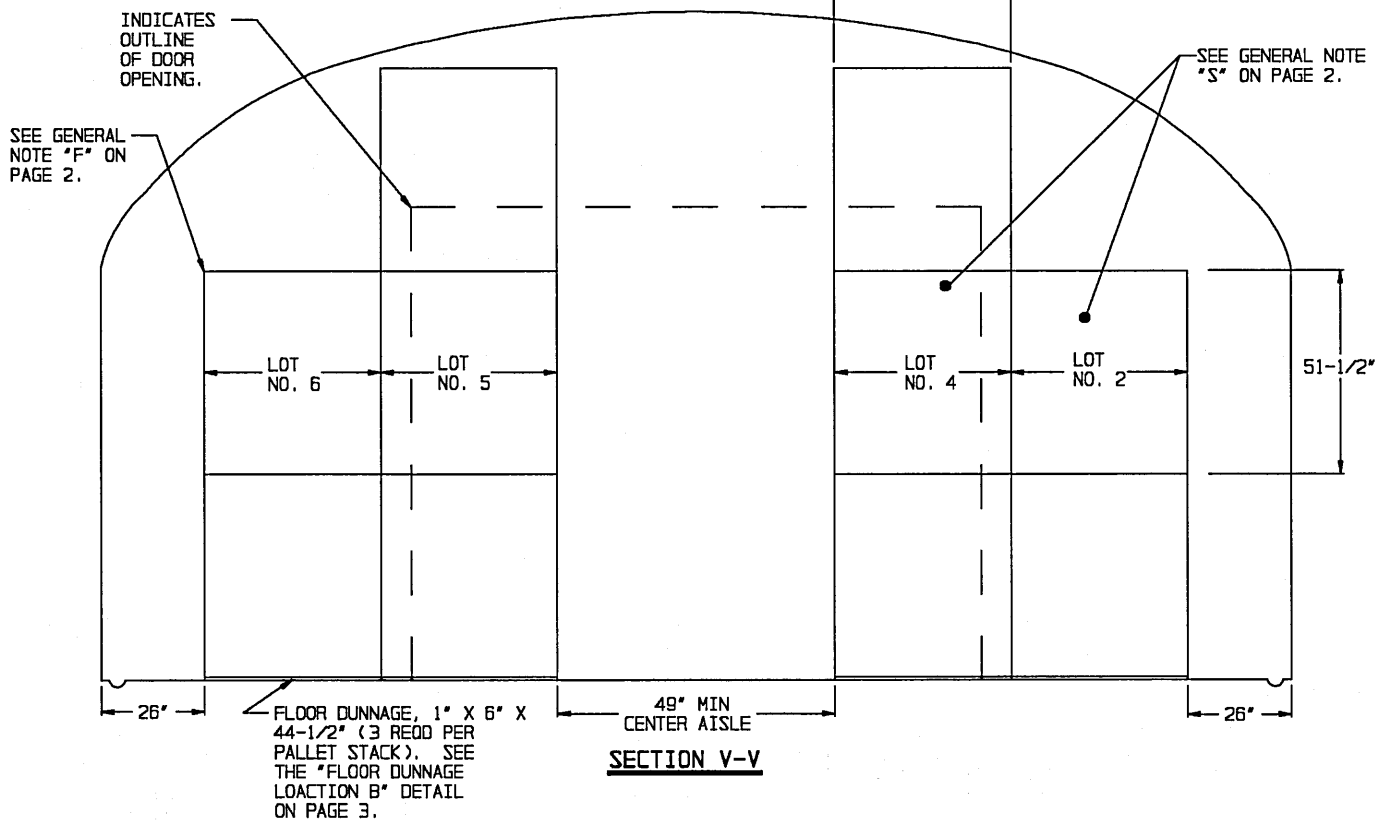

SECTION V-V

SPECIAL NOTES:

1. THE STORAGE PLANS AND CONFIGURATIONS SHOWN ON THIS PAGE ARE TYPICAL ONLY AND APPLY TO RELATIVELY LARGE LOTS. ADAPTATIONS MAY BE MADE AS NUMBER AND SIZES OF LOTS TO BE STORED IN MAGAZINE REQUIRE.
2. AN INSPECTION/INVENTORY AISLE MUST BE PROVIDED AT ONE SIDE OR END OF EACH LOT.
3. GENERALLY, THE LARGEST LOT SHOULD BE STORED IN THE REAR OF THE MAGAZINE. HOWEVER, THE REAR AREA MAY BE USED TO STORE MORE THAN ONE LOT BY ERECTING ROWS SIMILAR TO THOSE SHOWN IN THE FRONTAL AREA. A CENTER AISLE WILL NOT BE REQUIRED IN THE REAR AREA AS LONG AS EACH LOT IS ACCESSIBLE FOR REMOVAL AND INSPECTION/INVENTORY IN ACCORDANCE WITH OTHER CRITERIA SPECIFIED IN THESE SPECIAL NOTES AND IN THE GENERAL NOTES ON PAGE 2.

(SPECIAL NOTES CONTINUED)

4. EACH LOT WITHIN THE MAGAZINE MUST BE ACCESSIBLE FOR MOVEMENT BY MHE. A SINGLE-LOT OF PALLET UNITS IS CONSIDERED "ACCESSIBLE" IF NO MORE THAN TWELVE (12) "LIFTS" OF ANOTHER LOT OR LOTS HAVE TO BE MADE TO GAIN ACCESS TO THAT LOT. A "LIFT" MAY CONSIST OF ONE (1) OR MORE PALLET UNITS, PROVIDING THE CAPACITY OF THE MHE PERMITS, AND SAFE HANDLING IS NOT JEOPARDIZED.
5. FOR STORAGE OF MULTIPLE-LOTS, THE DISTANCE FROM THE SIDE WALL WILL BE BASED ON THE OVERHEAD CLEARANCE REQUIRED FOR THE MHE.
6. WHEN TWO LOTS ARE STORED ADJACENT TO EACH OTHER, THEY SHOULD BE SEPARATED BY AT LEAST 1" TO PROVIDE CLEARANCE FOR REMOVAL OF EITHER LOT.

(CONTINUED AT RIGHT)

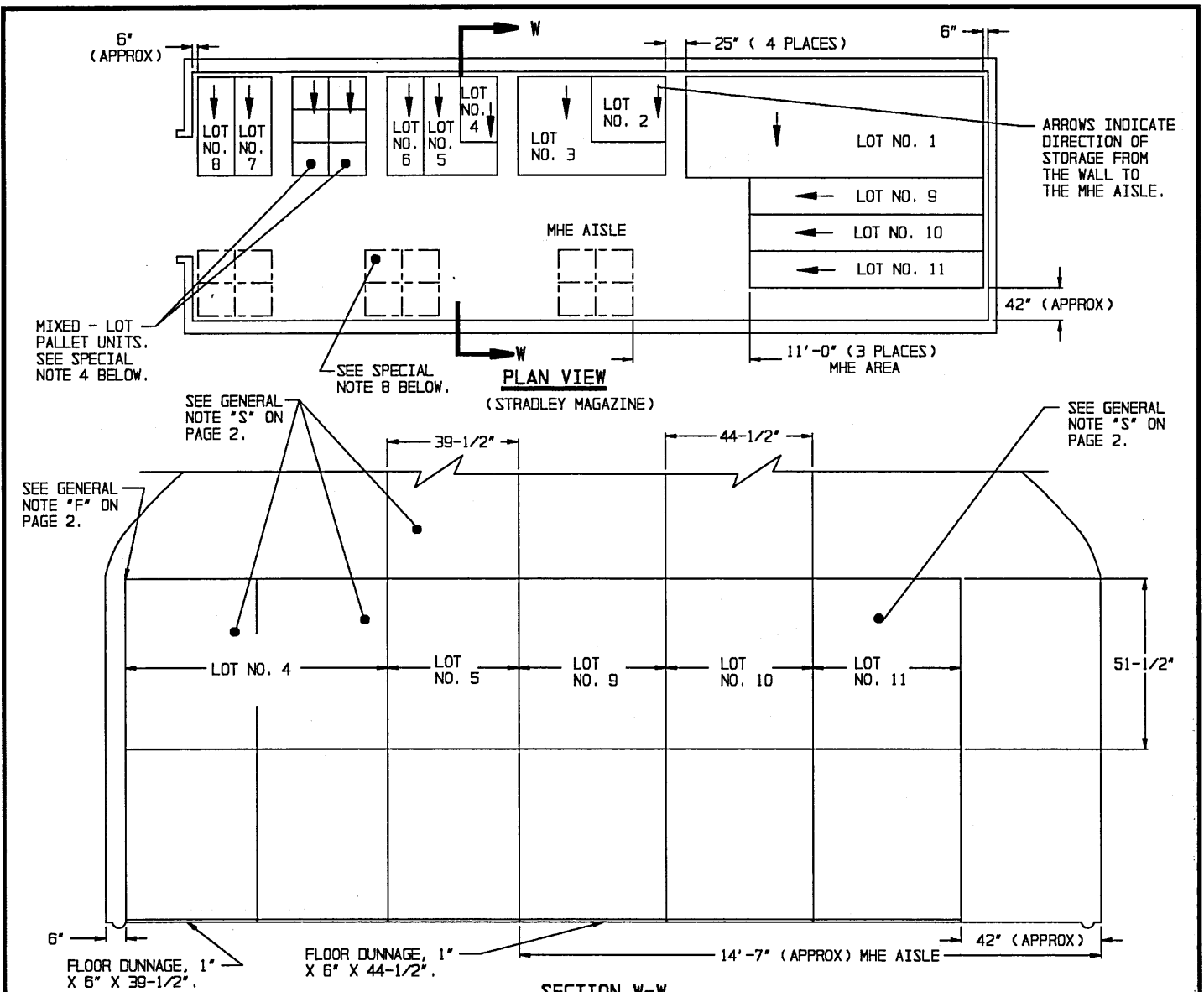

SECTION W-W

(SPECIAL NOTES CONTINUED)

SPECIAL NOTES:

1. THE STORAGE PLANS AND CONFIGURATIONS SHOWN ON THIS PAGE ARE TYPICAL ONLY AND APPLY TO STORAGE OF NUMEROUS LOTS. ADAPTATIONS MAY BE MADE AS NUMBER AND SIZES OF LOTS TO BE STORED IN MAGAZINE REQUIRE.
2. AN INSPECTION/INVENTORY AISLE NOT LESS THAN 18" MUST BE PROVIDED AT ONE SIDE OF EACH "BURIED" LOT.
3. GENERALLY, THE LARGEST LOT SHOULD BE STORED IN THE REAR OF THE MAGAZINE. HOWEVER, THE REAR AREA MAY BE USED TO STORE MORE THAN ONE LOT BY ERECTING STACKS SIMILAR TO THOSE SHOWN IN THE FRONTAL AREA. AN MHE AISLE WILL BE REQUIRED ON ONE SIDE OF THE MAGAZINE, AND EACH LOT MUST BE ACCESSIBLE FOR REMOVAL AND INSPECTION/INVENTORY IN ACCORDANCE WITH OTHER CRITERIA SPECIFIED IN THESE SPECIAL NOTES AND IN THE GENERAL NOTES ON PAGE 2.
4. A MIXED-LOT PALLET UNIT MAY HAVE FROM TWO LOTS PER PALLET UNIT UPWARD TO AS MANY DIFFERENT LOTS AS COMPLETE ROUNDS WITHIN THAT UNIT. HOWEVER, ALL COMPLETE ROUNDS AND LOTS WITHIN THE PALLET UNIT MUST HAVE THE SAME NATIONAL STOCK NUMBER AND CONDITION CODE.
5. EACH LOT WITHIN THE MAGAZINE MUST BE ACCESSIBLE FOR MOVEMENT BY MHE. PALLET UNITS OF A SINGLE-LOT OR MIXED-LOT PALLET UNITS ARE CONSIDERED "ACCESSIBLE" IF NO MORE THAN TWELVE (12) "LIFTS" OF ANOTHER LOT OR LOTS HAVE TO BE MADE TO GAIN ACCESS TO THE SINGLE-LOT OR MIXED-LOT UNITS. A "LIFT" MAY CONSIST OF ONE (1) OR MORE PALLET UNITS, PROVIDING THE CAPACITY OF THE MHE PERMITS AND SAFE HANDLING IS NOT JEOPARDIZED.
6. FOR STORAGE OF MULTIPLE LOTS, THE DISTANCE FROM THE SIDE-WALL WILL BE BASED ON THE OVERHEAD CLEARANCE REQUIRED FOR MHE.
7. WHEN TWO LOTS ARE STORED ADJACENT TO EACH OTHER, THEY SHOULD BE SEPARATED BY AT LEAST 1" TO PROVIDE CLEARANCE FOR REMOVAL OF EITHER LOT.
8. AREAS INCLUDED BY DOTTED LINES INDICATE LOCATIONS WHERE ADDITIONAL LOTS MAY BE STORED OR WHERE ADDITIONAL ITEMS MAY BE STORED, THAT ARE FROM THE LOT OR LOTS WHICH ARE DIRECTLY OR ALMOST DIRECTLY ACROSS THE CENTER AISLE ON THE OTHER SIDE OF THE MAGAZINE. COMPLIANCE WITH ALL OF THE MULTIPLE-LOT CRITERIA AS SET FORTH ON THIS PAGE MUST BE OBSERVED. THE SIZE OF THE LOTS BEING STORED AND THE CRITERIA OF SPECIAL NOTE 5, RELATIVE TO "12" LIFTS", WILL BE MAJOR FACTORS IMPACTING ON THE NUMBER OF UNIT LOADS THAT CAN BE STORED IN AN "ADDITIONAL STORAGE LOCATION". MORE OR FEWER STACKS THAN SHOWN MAY BE STORED AT ANY ONE OF THE ADDITIONAL STORAGE LOCATIONS. AN 11-FOOT MHE OPERATING AREA HAS BEEN SPECIFIED FOR ACCESS TO EACH "ADDITIONAL LOCATION" BY FORKLIFT TRUCK. THIS OPERATING AREA IS BASED ON REQUIREMENTS OF FORKLIFT TRUCKS COMMONLY USED IN STORAGE MAGAZINES. THE MHE OPERATING AREA CAN BE ENLARGED AS REQUIRED TO SUIT AVAILABLE FORKLIFT TRUCKS, AND SHOULD BE MADE SMALLER IF AVAILABLE MHE PERMITS. A "CENTER AISLE" (SPACE BETWEEN STORAGE ON ONE SIDE OF A MAGAZINE AND AN "ADDITIONAL STORAGE LOCATION") IS TO BE AT LEAST 49 INCHES WIDE. AN AISLE SLIGHTLY WIDER THAN 49 INCHES WILL ENHANCE FORKLIFT TRUCK MOVEMENT WITHIN A MAGAZINE; HOWEVER, THIS AISLE SHOULD NOT BE MADE WIDER IF A LOSS IN STORAGE RESULTS.

(CONTINUED AT RIGHT)

TYPICAL MULTIPLE-LOT STORAGE IN STRADLEY AND OVAL-ARCH TYPE MAGAZINES

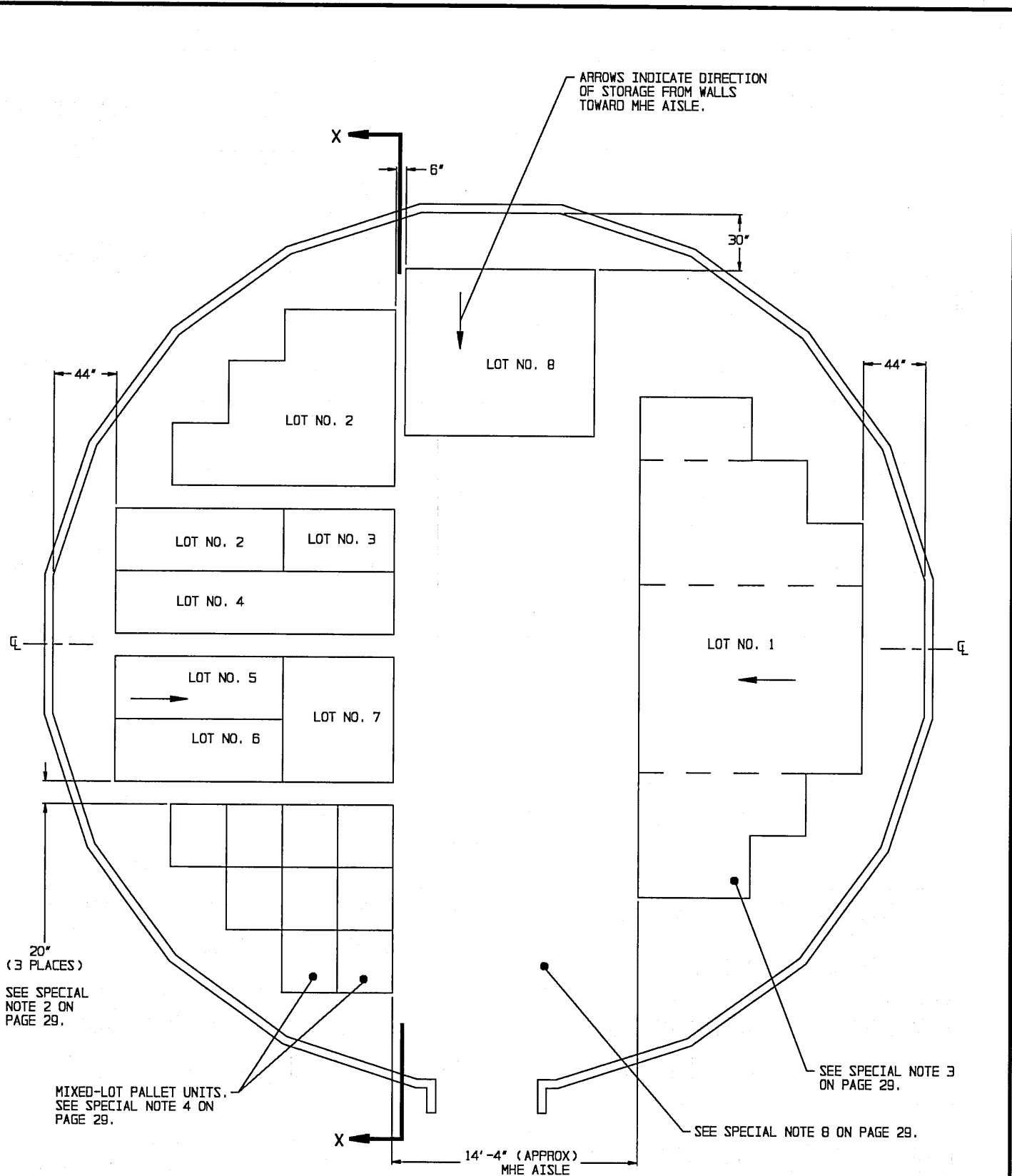

PLAN VIEW
(52'-0" DIA MAGAZINE)

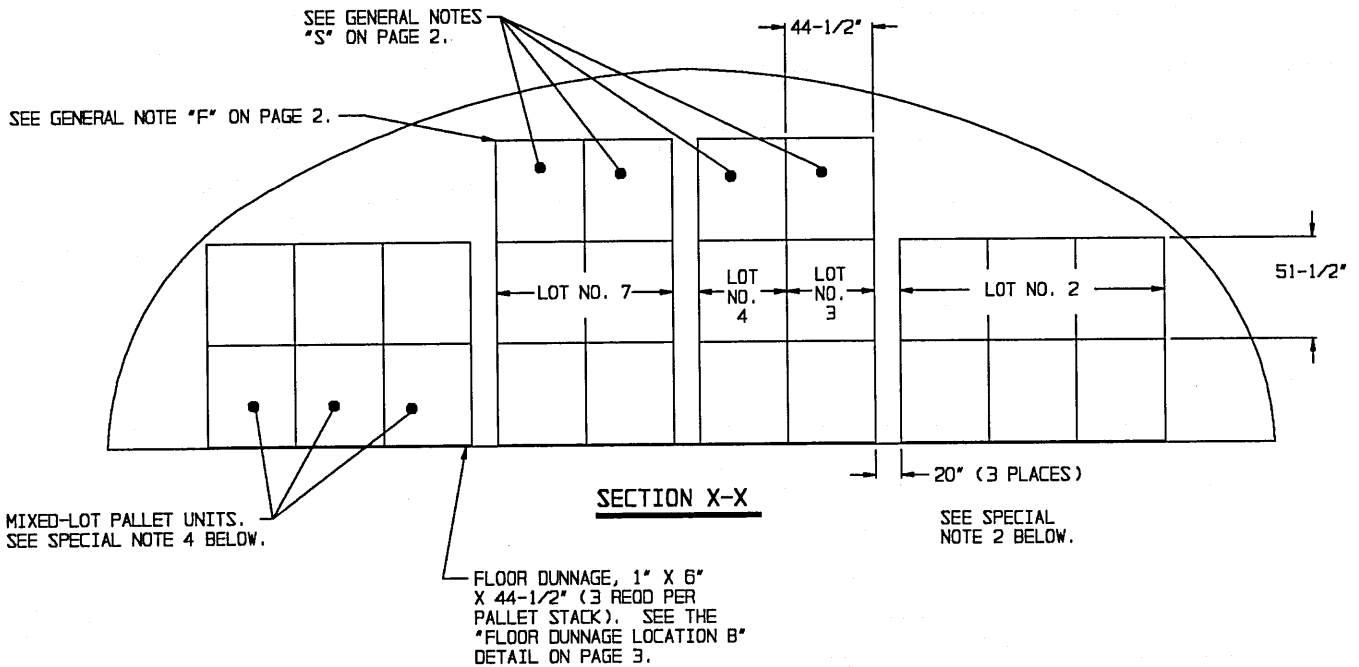

SPECIAL NOTES:

1. THE STORAGE PLANS SHOWN ARE TYPICAL ONLY. ADAPTATIONS MAY BE MADE AS NUMBER AND SIZES OF LOTS TO BE STORED IN MAGAZINE REQUIRE.
2. AN INSPECTION/INVENTORY AISLE NOT LESS THAN 18" WIDE MUST BE PROVIDED AT ONE SIDE OF EACH "BURIED" LOT.
3. GENERALLY, THE LARGEST LOT SHOULD BE STORED ON ONE SIDE OF THE MAGAZINE. HOWEVER, BOTH SIDES MAY BE USED TO STORE MORE THAN ONE LOT BY ERECTING ROWS SIMILAR TO THOSE SHOWN ON THE LEFT SIDE. EACH ADDITIONAL LOT MUST BE ACCESSIBLE FOR REMOVAL AND INSPECTION/INVENTORY IN ACCORDANCE WITH OTHER CRITERIA SPECIFIED IN THESE SPECIAL NOTES AND IN THE GENERAL NOTES ON PAGE 2.
4. A MIXED-LOT PALLET UNIT MAY HAVE FROM TWO LOTS PER PALLET UNIT UPWARDS TO AS MANY DIFFERENT LOTS AS COMPLETE ROUNDS WITHIN THAT UNIT. HOWEVER, ALL COMPLETE ROUNDS AND LOTS WITHIN THE PALLET UNIT MUST HAVE THE SAME NATIONAL STOCK NUMBER AND CONDITION CODE.
5. EACH LOT WITHIN THE MAGAZINE MUST BE ACCESSIBLE FOR MOVEMENT BY MHE. PALLET UNITS OF A SINGLE-LOT OR MIXED-LOT PALLET UNITS ARE CONSIDERED "ACCESSIBLE" IF NO MORE THAN TWELVE (12) "LIFTS" OF ANOTHER LOT OR LOTS HAVE TO BE MADE TO GAIN ACCESS TO THE SINGLE-LOT OR MIXED-LOT UNITS. A "LIFT" MAY CONSIST OF ONE (1) OR MORE PALLET UNITS, PROVIDING THE CAPACITY OF THE MHE PERMITS, AND SAFE HANDLING IS NOT JEOPARDIZED.
6. FOR STORAGE OF MULTIPLE-LOTS, THE DISTANCE FROM THE WALL WILL BE BASED ON THE OVERHEAD CLEARANCE REQUIRED FOR THE MHE.
7. WHEN TWO LOTS ARE STORED ADJACENT TO EACH OTHER, THEY SHOULD BE SEPARATED BY AT LEAST 1" TO PROVIDE CLEARANCE FOR REMOVAL OF EITHER LOT.
8. THE MHE AISLE MAY BE USED TO STORE ONE OR MORE STACKS OF ADDITIONAL LOTS OR ADDITIONAL ITEMS THAT ARE FROM A LOT ADJACENT TO THE MHE AISLE. THIS ADDITIONAL STORAGE IS TO BE ARRANGED IN A MANNER SIMILAR TO ARRANGEMENTS DEPICTED ON PAGES 25 AND 27 FOR THE "ADDITIONAL STORAGE LOCATIONS" SHOWN BY DOTTED LINES). ADEQUATE SPACE FOR MHE OPERATION, AS DESCRIBED ON PAGES 25 AND 27, MUST BE MADE AVAILABLE FOR THE ADDITIONAL STORAGE. ALSO COMPLIANCE WITH ALL OF THE MULTIPLE-LOT CRITERIA AS SET FORTH ON THIS PAGE MUST BE OBSERVED.

MIXED-LOT PALLET UNITS.
SEE SPECIAL NOTE 4 BELOW.

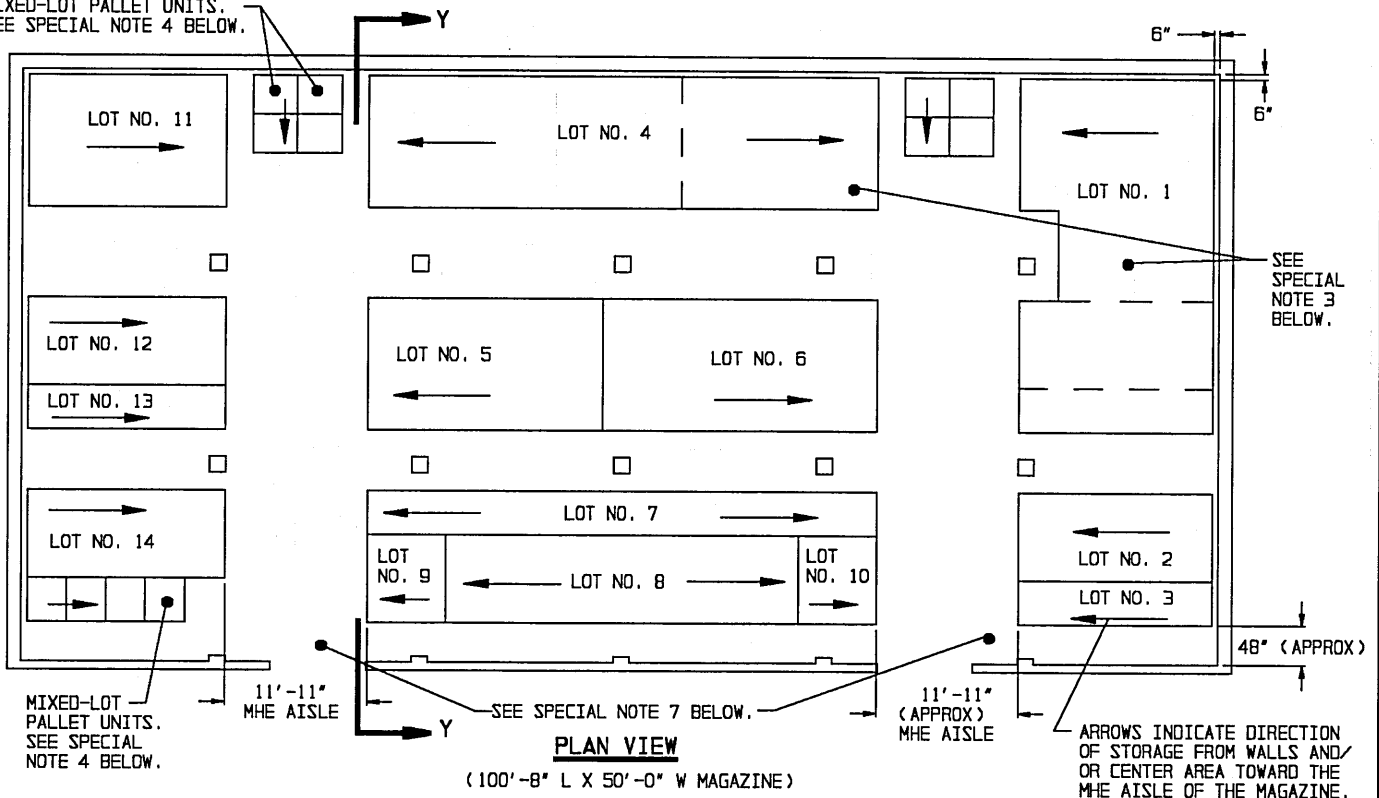

SEE GENERAL NOTE "S" ON PAGE 2.

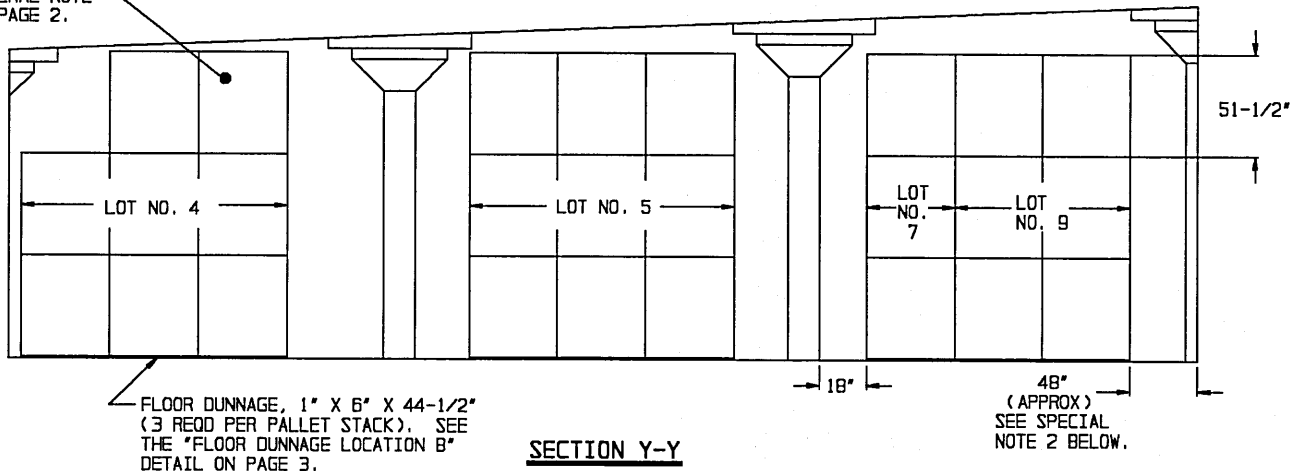

SPECIAL NOTES:

1. THE STORAGE PLANS SHOWN ARE TYPICAL ONLY. ADAPTATIONS MAY BE MADE AS NUMBER AND SIZES OF LOTS TO BE STORED IN MAGAZINE REQUIRE.
2. AN INSPECTION/INVENTORY AISLE NOT LESS THAN 18" WIDE MUST BE PROVIDED AT ONE SIDE OF EACH "BURIED" LOT.
3. GENERALLY, THE LARGEST LOT SHOULD BE STORED IN THE REAR OR ON ONE SIDE OF THE MAGAZINE. HOWEVER, THESE AREAS MAY BE USED TO STORE MORE THAN ONE LOT BY ERECTING ROWS SIMILAR TO THOSE SHOWN IN THE CENTER AREA OR AS TYPICALLY INDICATED BY DOTTED LINES. EACH ADDITIONAL LOT MUST BE ACCESSIBLE FOR REMOVAL AND INSPECTION/INVENTORY IN ACCORDANCE WITH OTHER CRITERIA SPECIFIED IN THESE SPECIAL NOTES AND IN THE GENERAL NOTES ON PAGE 2.
4. A MIXED-LOT PALLET UNIT MAY HAVE FROM TWO LOTS PER PALLET UNIT UPWARDS TO AS MANY DIFFERENT LOTS AS COMPLETE ROUNDS WITHIN THAT UNIT. HOWEVER, ALL COMPLETE ROUNDS AND LOTS WITHIN THAT UNIT MUST HAVE THE SAME NATIONAL STOCK NUMBER AND CONDITION CODE.
5. EACH LOT WITHIN THE MAGAZINE MUST BE ACCESSIBLE FOR MOVE-

(CONTINUED AT RIGHT)

(SPECIAL NOTES CONTINUED)

6. WHEN TWO LOTS ARE STORED ADJACENT TO EACH OTHER, THEY SHOULD BE SEPARATED BY AT LEAST 1" TO PROVIDE CLEARANCE FOR REMOVAL OF EITHER LOT.
7. THE MHE AISLE MAY BE USED TO STORE ONE OR MORE STACKS OF ADDITIONAL LOTS OR ADDITIONAL ITEMS THAT ARE FROM A LOT ADJACENT TO THE MHE AISLE. THIS ADDITIONAL STORAGE IS TO BE ARRANGED IN A MANNER SIMILAR TO THE ARRANGEMENTS DEPICTED ON PAGE 25 AND 27 FOR THE "ADDITIONAL STORAGE LOCATIONS" (SHOWN BY DOTTED LINES). ADEQUATE SPACE FOR MHE OPERATION, AS DESCRIBED ON PAGES 25 AND 27, MUST BE MADE AVAILABLE FOR THE ADDITIONAL STORAGE. ALSO COMPLIANCE WITH ALL OF THE MULTIPLE-LOT CRITERIA AS SET FORTH ON THIS PAGE MUST BE OBSERVED.