

STORAGE IN 81'-0", 60'-8", AND 40'-4" L X 26'-6" W X 12'-9" H IGLOO MAGAZINES OF PALLETIZED PROPELLING CHARGES

INDEX

ITEM	PAGE (S)
GENERAL NOTES, AND MATERIAL SPECIFICATIONS -----	2
ITEMIZED INDEX -----	3, 138
STORAGE DETAILS -----	4-121
TYPICAL MULTIPLE-LOT STORAGE PROCEDURES -----	122, 123
PALLET UNIT DETAILS -----	124-136

THIS DRAWING SUPERSEDES U.S. ARMY DARCOM DRAWING
19-48-4144/1-1PM1990 DATED OCTOBER 1979 AND REVISION NO. 1
THERETO.

REVISIONS		DRAFTSMAN	TYPIST	CHECKER	TECHNICIAN	ENGINEER
		63	68	01	PP	R. Arnold
2	MAY 91	RHA DAW WJF				
		David A. Pinkerik				
		William J. Ernst				
		DEV				
		DEO				
		DE				
		DEV				
		DEO				
		DE				
		DEV				
		DEO				
		DE				
		DEV				
		DEO				
		DE				
		DEV				
		DEO				
		DE				
		DEV				
		DEO				
		DE				
		DEV				
		DEO				
		DE				
		DEV				
		DEO				
		DE				
		DEV				
		DEO				
		DE				
		DEV				
		DEO				
		DE				
		DEV				
		DEO				
		DE				
		DEV				
		DEO				
		DE				
		DEV				
		DEO				
		DE				
		DEV				
		DEO				
		DE				
		DEV				
		DEO				
		DE				
		DEV				
		DEO				
		DE				
		DEV				
		DEO				
		DE				
		DEV				
		DEO				
		DE				
		DEV				
		DEO				
		DE				
		DEV				
		DEO				
		DE				
		DEV				
		DEO				
		DE				
		DEV				
		DEO				
		DE				
		DEV				
		DEO				
		DE				
		DEV				
		DEO				
		DE				
		DEV				
		DEO				
		DE				
		DEV				
		DEO				
		DE				
		DEV				
		DEO				
		DE				
		DEV				
		DEO				
		DE				
		DEV				
		DEO				
		DE				
		DEV				
		DEO				
		DE				
		DEV				
		DEO				
		DE				
		DEV				
		DEO				
		DE				
		DEV				
		DEO				
		DE				
		DEV				
		DEO				
		DE				
		DEV				
		DEO				
		DE				
		DEV				
		DEO				
		DE				
		DEV				
		DEO				
		DE				
		DEV				
		DEO				
		DE				
		DEV				
		DEO				
		DE				
		DEV				
		DEO				
		DE				
		DEV				
		DEO				
		DE				
		DEV				
		DEO				
		DE				
		DEV				
		DEO				
		DE				
		DEV				
		DEO				
		DE				
		DEV				
		DEO				
		DE				
		DEV				
		DEO				
		DE				
		DEV				
		DEO				
		DE				
		DEV				
		DEO				
		DE				
		DEV				
		DEO				
		DE				
		DEV				
		DEO				
		DE				
		DEV				
		DEO				
		DE				
		DEV				
		DEO				
		DE				
		DEV				
		DEO				
		DE				
		DEV				
		DEO				
		DE				
		DEV				
		DEO				
		DE				
		DEV				
		DEO				
		DE				
		DEV				
		DEO				
		DE				
		DEV				
		DEO				
		DE				
		DEV				
		DEO				
		DE				
		DEV				
		DEO				
		DE				
		DEV				
		DEO				
		DE				
		DEV				
		DEO				
		DE				
		DEV				
		DEO				
		DE				
		DEV				
		DEO				
		DE				
		DEV				
		DEO				
		DE				
		DEV				
		DEO				
		DE				
		DEV				
		DEO				
		DE				
		DEV				
		DEO				
		DE				
		DEV				
		DEO				
		DE				
		DEV				
		DEO				
		DE				
		DEV				
		DEO				
		DE				
		DEV				
		DEO				
		DE				
		DEV				
		DEO				
		DE				
		DEV				
		DEO				
		DE				
		DEV				
		DEO				
		DE				
		DEV				
		DEO				
		DE				
		DEV				
		DEO				
		DE				
		DEV				
		DEO				
		DE				
		DEV				
		DEO				
		DE				
		DEV				
		DEO				
		DE				
		DEV				
		DEO				
		DE				
		DEV				
		DEO				
		DE				
		DEV				
		DEO				
		DE				
		DEV				
		DEO				
		DE				
		DEV				
		DEO				
		DE				
		DEV				
		DEO				
		DE				
		DEV				
		DEO				
		DE				
		DEV				

GENERAL NOTES

- A. THIS DOCUMENT HAS BEEN PREPARED AND ISSUED IN ACCORDANCE WITH AR 740-1, AND AUGMENTS TM 743-200-1 (CHAPTER 5).
- B. THE STORAGE PROCEDURES DEPICTED WITHIN THIS DOCUMENT ARE APPLICABLE FOR STORAGE OF PALLETIZED PROPELLING CHARGES IN 81'-0", 60'-8", AND 40'-4" LONG BY 26'-6" WIDE BY 12'-9" HIGH IGLOO MAGAZINES. THE STORAGE PROCEDURES DEPICTED MAY ALSO BE UTILIZED TO STORE PALLET UNITS IN OTHER SIMILAR TYPES OF APPROVED MAGAZINES. MINOR ADJUSTMENTS MAY BE MADE TO FACILITATE STORAGE IN OTHER TYPES OF MAGAZINES, HOWEVER, THE BASIC PRINCIPLES AS DEPICTED HEREIN WILL BE FOLLOWED.
- C. **CAUTION:** THE ALLOWABLE "EXPLOSIVE LIMIT" ESTABLISHED FOR A MAGAZINE IS NOT TO BE EXCEEDED.
- D. STORED PALLET UNITS MUST NOT CONTACT THE WALLS OF A MAGAZINE. TO PROVIDE FOR THIS MANDATORY CLEARANCE REQUIREMENT, UNITS MAY BE ELIMINATED FROM THE DEPICTED STORAGE PATTERNS AS NECESSARY.
- E. AISLE DIMENSIONS SHOWN FOR STORAGE IN MAGAZINES MAY BE ADJUSTED TO SUIT LOCAL CONDITIONS, VARIATIONS IN PALLET DIMENSIONS, AND/OR AVAILABLE MATERIALS HANDLING EQUIPMENT.
- F. THE USE OF "FLOOR DUNNAGE" UNDER METAL PALLETS IS OPTIONAL, ALTHOUGH THE USE OF THIS TYPE OF DUNNAGE IS DELINEATED WITHIN THIS STORAGE PROCEDURE DRAWING. THE PURPOSE OF FLOOR DUNNAGE IS TO HELP KEEP THE RUNNERS OF A PALLET DRY, THUS AIDING IN PREVENTING DETERIORATION DUE TO OXIDATION (RUSTING). THEREFORE, FLOOR DUNNAGE SHOULD BE USED WHEN STORING IN A MAGAZINE THAT IS KNOWN TO HAVE A "DAMP" FLOOR. ALSO, IN LIEU OF USING ONE-INCH THICK FLOOR DUNNAGE AS SPECIFIED, THE USE OF THICKER FLOOR DUNNAGE MAY BE REQUIRED, AND SHOULD BE USED, TO ACHIEVE THE DESIRED OBJECTIVE. SEE THE "FLOOR DUNNAGE LOCATION DETAIL" ON PAGE 5 FOR A TYPICAL INSTALLATION.
- G. IF AVAILABLE MHE PERMITS, ADDITIONAL PALLETIZED UNITS MAY BE STORED WITHIN THE MHE AREA AND/OR OTHER AVAILABLE AREAS OF A MAGAZINE.
- H. THE HEIGHT OF THE PACKAGE GUARD ON SOME FORKLIFT TRUCKS MAY NOT PERMIT PLACEMENT OF SOME TOP LAYER UNITS IN THE STACKS SHOWN IN THE STORAGE VIEWS HEREIN, UNLESS TWO UPPER PALLET UNITS ARE HANDLED AS ONE LIFT OR THE PACKAGE GUARD IS REMOVED (TINE CARRIAGE WILL IN MOST INSTANCES PROVIDE ADEQUATE PACKAGE GUARD PROTECTION). ONLY A FORKLIFT OF ADEQUATE CAPACITY WILL BE USED WHEN LIFTING TWO PALLET UNITS AS ONE LIFT.
- J. STACK-STABILIZING DUNNAGE IN THE FORM OF "SHIMS" PROBABLY WILL BE REQUIRED TO ACHIEVE SOUND AND ACCEPTABLE STABLE STACKS. SHIM MATERIAL OF VARYING THICKNESSES WILL BE USED AS REQUIRED TO GAIN LEVEL OR NEARLY LEVEL STACKS AND SOLID BEARING WITHIN A STACK FROM THE FLOOR OF A MAGAZINE TO THE TOP OF THE STACK.
- K. THE PROCEDURES WITHIN THIS DRAWING DEPICT THE STORAGE OF ONLY ONE LOT PER MAGAZINE OF ONE PALLET UNIT ITEM. HOWEVER, MORE THAN ONE LOT OF AN ITEM MAY BE STORED, AS TYPICALLY SHOWN ON PAGES 122 AND 123, OR OTHER PROPELLING CHARGE ITEMS MAY BE STORED IN THE SAME MAGAZINE.
- L. STORAGE OF MULTIPLE LOTS IN A MAGAZINE WILL REQUIRE CAREFUL PREPLANNING SO AS TO INSURE MHE ACCESSIBILITY TO ANY LOT IN ACCORDANCE WITH REQUIREMENTS SET FORTH IN THE "SPECIAL NOTES" SECTION OF THE MULTIPLE-LOT STORAGE PROCEDURES TYPICALLY SHOWN ON PAGES 122 AND 123.

(CONTINUED AT RIGHT)

MATERIAL SPECIFICATIONS

LUMBER : SEE TM 743-200-1, DUNNAGE LUMBER, FED SPEC MM-L-751.

(GENERAL NOTES CONTINUED)

- M. ALTHOUGH SPECIFIC PROCEDURES ARE INCLUDED IN THIS DRAWING FOR STORING MULTIPLE-LOTS, THE BASIC STORAGE PATTERNS AS SHOWN ON PAGES 4 THRU 27 AND 36 THRU 115 CAN ALSO BE ADAPTED FOR THE STORING OF MORE THAN ONE LOT. LOTS WHEN STORED IN ACCORDANCE WITH A BASIC STORAGE PATTERN MAY BE STORED WITH ONE OR MORE ROWS USED FOR EACH LOT. A SPACE OF APPROXIMATELY 1" WILL HAVE TO BE LEFT BETWEEN ADJACENT ROWS CONTAINING DIFFERENT LOTS. IN BASIC STORAGE PATTERNS WHERE THE WIDTH OF A ROW IS ESTABLISHED BY THE 45-1/2" OR 48" WIDTH DIMENSION OF THE PALLET, EACH ROW MAY BE A DIFFERENT LOT AND BE READILY AVAILABLE. IN BASIC STORAGE PATTERNS WHERE THE WIDTH OF A ROW IS ESTABLISHED BY THE 35" OR 40" LENGTH DIMENSION OF THE PALLET, A LOT MUST CONSIST OF TWO OR MORE ROWS TO PROVIDE ADEQUATE SPACE TO ACCOMMODATE THE WIDTH OF A FORKLIFT TRUCK FOR STORING OR REMOVING THE LOT. AN EXCEPTION TO THIS WOULD BE UNITS NO. 40, 41, AND 42 WHICH ARE APPROXIMATELY 44" LONG AND THEREFORE EACH ROW CAN BE A DIFFERENT LOT. HOWEVER, WHEN THE SIZE OF A LOT REQUIRES THE SPACE OF ONLY ONE ROW, IT IS PERMISSIBLE TO STORE THAT LOT WITH THE 45-1/2" OR 48" LENGTH DIMENSION OF THE PALLET ESTABLISHING THE WIDTH OF THE ROW, PROVIDING THE STORAGE PRINCIPLES SPECIFIED ARE FOLLOWED AS CLOSELY AS POSSIBLE. THE 1" SPACE BETWEEN LOTS, AS STATED ABOVE, WILL NOT BE EXCEEDED SOLELY TO ACCOMMODATE THE WIDTH OF A FORKLIFT TRUCK. ALSO, WHEN A BASIC STORAGE PATTERN IS USED FOR STORING MULTIPLE-LOTS, IT IS REQUIRED AND PERMISSIBLE TO ELIMINATE THE USE OF A STAGGERED - LAYER STORAGE PATTERN AS SHOWN. FOR ADDITIONAL REQUIREMENTS AND GUIDANCE, SEE THE SPECIAL NOTES FOR MULTIPLE-LOT STORAGE ON PAGES 122 AND 123.
- N. ANY "LIGHT" PALLETIZED UNIT THAT DOES NOT CONTAIN A FULL QUANTITY OF PROPELLING CHARGES WILL NOT BE BURIED IN STORAGE. IT MUST BE POSITIONED ADJACENT TO AN AISLE, PREFERABLY IN FRONT OF THE LOT OR ON TOP OF THE LAST STACK ADJACENT TO OR NEAREST THE MHE AISLE.
- O. PROPELLING CHARGES PRESENTLY STORED IN ACCORDANCE WITH A PRIOR APPROVED DRAWING NEED NOT BE RE-STORED SOLELY TO CONFORM TO THE PROCEDURES SPECIFIED IN THIS DOCUMENT.
- P. THE PROCEDURES DEPICTED WITHIN THIS DRAWING MAY BE APPLIED FOR THE STORING OF PALLETIZED PROPELLING CHARGES OTHER THAN THOSE LISTED IN THE ITEMIZED INDEX ON PAGES 3 AND 138. SELECT FROM THE PALLET UNIT DIMENSION COLUMN OF THE INDEX THE PALLET UNIT WHICH HAS LENGTH AND WIDTH DIMENSIONS NEAREST THE LENGTH AND WIDTH OF THE UNIT TO BE STORED. APPLY THE STORAGE PRINCIPLES SHOWN FOR THAT UNIT ON THE DESIGNATED STORAGE DETAIL PAGE, ADJUSTING STACK HEIGHTS, AS REQUIRED.
- Q. STORAGE OF NON-STANDARD PALLET UNITS, SUCH AS FIELD RETURNS, SHOULD BE HANDLED ON A CASE BY CASE BASIS. GUIDANCE FOR STORAGE OF THESE NON-STANDARD PALLET UNITS SHOULD BE REQUESTED FROM THE U.S. ARMY ARMAMENT, RESEARCH, DEVELOPMENT AND ENGINEERING CENTER, ATTN: SMCAR-ESK, ROCK ISLAND, IL 61299-7300.
- R. DUNNAGE LUMBER SPECIFIED THROUGHOUT THIS PROCEDURAL DRAWING IS OF NOMINAL SIZE. FOR EXAMPLE, 1" X 6" MATERIAL IS ACTUALLY 3/4" THICK BY 5-1/2" WIDE.
- S. PORTIONS OF THE MAGAZINES, SUCH AS SIDEWALLS, END WALLS, AND ROOFS, HAVE NOT BEEN SHOWN IN THE STORAGE VIEWS FOR CLARITY PURPOSES.
- T. WHEN STORING PALLET UNITS IN A BLOCK PATTERN AS DEPICTED ON PAGES 4 THRU 121, THE FOLLOWING GUIDANCE IS TO BE FOLLOWED. WHEN THE SPECIFIED STORAGE PATTERN DEPICTS THE UNITS POSITIONED SO THE CONTAINERS IN THE UNITS ARE CROSSWISE IN THE MAGAZINE, THE UNITS AT THE END OF EACH STACK WILL BE POSITIONED SO THAT THE OPENING ENDS OF THE CONTAINERS FACE TOWARD THE SIDEWALL OF THE MAGAZINE. WHEN THE STORAGE PATTERN DEPICTS THE UNITS POSITIONED SO THE CONTAINERS IN THE UNIT ARE LENGTHWISE IN THE MAGAZINE, THE UNITS WILL BE POSITIONED SO THE OPENING ENDS FACE THE DOOR, IF APPLICABLE.
- U. WHEN LOCAL STORAGE CONDITIONS ARE SUCH THAT AN AMMUNITION STORAGE MAGAZINE NET EXPLOSIVE WEIGHT LIMIT WILL BE REACHED BEFORE ALL AVAILABLE STORAGE SPACE WILL BE UTILIZED A COMBINATION OF THE VARIOUS STORAGE PATTERNS DELINEATED HEREIN MAY BE USED IN LIEU OF BLOCK STORAGE PATTERN TO FACILITATE INVENTORY, INSPECTION, THE USE OF MATERIALS HANDLING EQUIPMENT, SURVEILLANCE, ETC., OF THE AMMUNITION TO BE STORED WITHIN THE MAGAZINE.
- V. A PRODUCTION OR STORAGE FACILITY IS AUTHORIZED TO HAVE ONE INCOMPLETE, UNBANDIED PARTIAL UNIT LOAD PER LOT IN A STORAGE STRUCTURE. PRIOR TO SHIPMENT OF A PARTIAL UNIT, A LAYER MUST BE COMPLETED, IF APPLICABLE, BY THE POSITIONING OF ONE OR MORE EMPTY CONTAINERS OR FILLERS AS DELINEATED BY THE APPLICABLE UNITIZATION PROCEDURES. THE UNIT MUST THEN BE RE-BANDIED WITH THE SAME SIZE AND QUANTITY OF STRAPS AS THE ORIGINAL UNIT.

REVISIONS

REVISION NO. 1, DATED NOVEMBER 1981 CONSISTS OF:

1. ADDING PALLET UNIT DETAILS AND STORAGE PROCEDURES FOR PALLET UNITS NOS. 62 THRU 70.

REVISION NO. 2, DATED MAY 1991, CONSISTS OF:

1. CHANGING DRAWING APPROVAL BLOCK FROM U.S. ARMY DARCOM TO U.S. ARMY MATERIEL COMMAND.
2. ADDING UNIT DETAILS AND STORAGE PROCEDURES FOR UNITS NO. 71, 72, AND 73.
3. CHANGING STORAGE PROCEDURES ON PAGES 38, 40, 48, 51, 71, 77, 111, 114, AND 116.
4. ADDING GENERAL NOTES "T", "U", AND "V".

ITEMIZED INDEX

LINE NO. *	ITEM IDENTIFICATION	PALLET UNIT DIMENSIONS L X W X H (INCHES)	UNIT WEIGHT (POUNDS)	UNIT NO.	UNIT DETAIL PAGE	STORAGE DETAIL PAGE
1	155MM M3 IN M14 CNTR, AMPHIBIOUS UNIT	41 X 48 X 37-1/8	1,275	1	124	4, 5
2	155MM M2 IN M16 CNTR, AMPHIBIOUS UNIT	42-3/4 X 50-3/4 X 41-1/2	1,456	2	124	6
3	5 1/8 IN MK9 MOD 1 AND MK15 MOD 1 CART TANK	35 X 50-1/2 X 51-7/8	1,890 (MAX)	3	124	7
4	5 1/8 IN MK9 AND MK15 CART TANK IN PALLET ADAPTER MK13 MOD 0	35 X 47-13/16 X 43-7/8	1,721 (MAX)	4	124	8
5	5 1/8 IN MK9 AND MK15 CART TANK IN WOOD FRAMES	35 X 50-1/2 X 39-3/4	1,484 (MAX)	5	124	9
6	5 1/4 IN MK14 CART TANK	36-3/8 X 50-1/2 X 51-5/8	1,943	6	124	10
7	5 1/4 IN MK14, MK14 MOD 1 AND MK21 MOD 0 CART TANK IN PALLET ADAPTER MK16 MOD 0	36-1/2 X 48 X 43-3/8	1,789 (MAX)	7	125	11
8	5 1/4 IN MK14 AND MK21 CART TANK IN WOOD FRAMES	36-3/8 X 50-1/2 X 39-3/4	1,508 (MAX)	8	125	12
9	6 1/4 IN MK14 CART TANK	40-1/2 X 45-1/2 X 49-5/8	1,685	9	125	13
10	6 1/4 IN MK4 CART TANK IN PALLET ADAPTER MK18 MOD 0	39-3/8 X 45-1/2 X 40-3/8	1,317	10	125	14
11	6 1/4 IN MK4 CART TANK IN WOOD FRAMES	40-1/2 X 45-1/2 X 41-7/8	1,356 (MAX)	11	125	15
12	8 1/5 IN MK10 MOD 1 POWDER TANK ON STEEL PALLET	35 X 56-1/4 X 46-3/4	1,479	12	125	16
13	8 1/5 IN MK10 MOD 1 POWDER TANK ON WOOD PALLET	40 X 48 X 36-3/4	1,029	13	126	17
14	8 1/5 IN MK13 MOD 0 POWDER TANK ON WOOD PALLET	40 X 51-5/8 X 33-3/4	916	14	126	18
15	8 1/5 IN MK11 AND MK13 MOD 0 CART TANK	42-1/8 X 54-5/8 X 45-5/8	1,633 (MAX)	15	126	19
16	8 1/5 IN MK10 MOD 1 POWDER TANK IN ADAPTER MK75 MOD 0	35 X 45-1/2 X 35-5/8	997	16	126	20
17	8 1/5 IN MK11 MOD 0 AND MK13 MOD 0 CART TANK IN ADAPTER MK76 MOD 0	41-3/8 X 55-1/2 X 43	1,712	17	126	21
18	8 IN MK13 MOD 0 POWDER TANK IN PALLET ADAPTER MK85 MOD 0	35 X 50-1/2 X 32-5/8	896	18	126	22
19	8 IN M1 IN M18 CNTR, AMPHIBIOUS UNIT	44 X 52-1/2 X 41-1/4	1,448	19	127	23
20	8 IN M2 IN M19 CNTR, AMPHIBIOUS UNIT	41-1/4 X 49-1/2 X 35-1/2	1,153	20	127	24
21	16 1/2 IN MK4 POWDER TANK ON PALLET ADAPTER MK87 MOD 0	40-1/2 X 60-3/4 X 60-7/8	2,916 (MAX)	21	127	25
22	16 1/2 IN MK8 MOD 0 POWDER TANK ON PALLET ADAPTER MK86 MOD 0	35-1/4 X 50 X 60-1/8	1,610	22	127	26
23	M67 CHARGE IN STEEL DRUM	40 X 52-1/2 X 32	767	23	127	27
24						
25						
26						
27						
28						
29						
30						
31	M10 CNTR, ALTERNATED CONTAINERS	40-3/4 X 55-3/8 X 35-1/2	1,632	31	129	36
32	M10 CNTR, ALTERNATED CONTAINERS (INCREASED-HEIGHT UNIT)	40-3/4 X 55-3/8 X 45-1/4	2,174	31	129	37
33	M10 CNTR, FLAT DUNNAGE METHOD	43 X 55-3/8 X 49	2,123	32	129	38
34	M10 CNTR, FLAT DUNNAGE METHOD (DECREASED-HEIGHT UNIT)	43 X 55-3/8 X 38-1/2	1,623	32	129	39
35	M10 CNTR, ROUTED DUNNAGE METHOD	42 X 55-3/8 X 48-5/8	2,119	33	129	40
36	M10 CNTR, ROUTED DUNNAGE METHOD (DECREASED-HEIGHT UNIT)	42 X 55-3/8 X 38	1,623	33	129	41
37	M13 CNTR, FLAT DUNNAGE METHOD	41-1/2 X 55 X 45-7/8	1,747	34	129	42
38	M13 CNTR, FLAT DUNNAGE METHOD (DECREASED-HEIGHT UNIT)	41-1/2 X 55 X 38-1/8	1,421	34	129	43
39	M13 CNTR, ROUTED DUNNAGE METHOD	40 X 55 X 44-7/8	1,761	35	129	44
40	M13 CNTR, ROUTED DUNNAGE METHOD (DECREASED-HEIGHT UNIT)	40 X 55 X 37-1/8	1,447	35	129	45
41	M14 CNTR, ALTERNATED CONTAINERS	37-1/2 X 49-1/2 X 36	1,304	36	129	46
42	M14 CNTR, ALTERNATED CONTAINERS (INCREASED-HEIGHT UNIT)	37-1/2 X 49-1/2 X 41-15/16	1,554	36	129	47
43	M14 CNTR, FLAT DUNNAGE METHOD	40-1/2 X 49-1/2 X 47-1/8	1,433	37	130	48
44	M14 CNTR, FLAT DUNNAGE METHOD (DECREASED-HEIGHT UNIT)	40-1/2 X 49-1/2 X 40-7/16	1,219	37	130	49
45	M14 CNTR, ROUTED DUNNAGE METHOD	40-1/2 X 48 X 47	1,435	38	130	50
46	M14 CNTR, ROUTED DUNNAGE METHOD (DECREASED-HEIGHT UNIT)	40-1/2 X 48 X 40-1/4	1,225	38	130	51
47	M16 CNTR, ALTERNATED CONTAINERS	42-5/8 X 49 X 36-1/4	1,472	39	130	52
48	M16 CNTR, ALTERNATED CONTAINERS (INCREASED-HEIGHT UNIT)	42-5/8 X 49 X 44	1,820	39	130	53
49	M16 CNTR, FLAT DUNNAGE METHOD	44-1/8 X 52-1/2 X 49	1,870	40	130	54
50	M16 CNTR, FLAT DUNNAGE METHOD (DECREASED-HEIGHT UNIT)	44-1/8 X 52-1/2 X 40-5/8	1,524	40	130	55
51	M16 CNTR, ROUTED DUNNAGE METHOD	44-1/8 X 50-1/2 X 48-3/4	1,848	41	130	56
52	M16 CNTR, ROUTED DUNNAGE METHOD (DECREASED-HEIGHT UNIT)	44-1/8 X 50-1/2 X 40-1/4	1,507	41	130	57
53	M18 CNTR, FLAT DUNNAGE METHOD	44 X 52-9/16 X 49	1,779	42	130	58
54	M18 CNTR, FLAT DUNNAGE METHOD (DECREASED-HEIGHT UNIT)	44 X 52-9/16 X 40-5/8	1,444	42	130	59
55	M18 CNTR, ROUTED DUNNAGE METHOD	42 X 52-9/16 X 48-3/4	1,792	43	131	60
56	M18 CNTR, ROUTED DUNNAGE METHOD (DECREASED-HEIGHT UNIT)	42 X 52-9/16 X 40-1/4	1,468	43	131	61
57	M19 CNTR, FLAT DUNNAGE METHOD	40-5/8 X 58-1/2 X 46-1/4	1,872	44	131	62
58	M19 CNTR, FLAT DUNNAGE METHOD (DECREASED-HEIGHT UNIT)	40-5/8 X 58-1/2 X 36-1/2	1,431	44	131	63
59	M19 CNTR, ROUTED DUNNAGE METHOD	40 X 58-1/2 X 45-7/8	1,873	45	131	64
60	M19 CNTR, ROUTED DUNNAGE METHOD (DECREASED-HEIGHT UNIT)	40 X 58-1/2 X 36	1,443	45	131	65
61	M460 CNTR, ALTERNATED CONTAINERS	40 X 55 X 42-5/8	1,965	46	131	66
62	M460 CNTR, ALTERNATED CONTAINERS (INCREASED-HEIGHT UNIT)	40 X 55 X 51-5/8	2,364	46	131	67
63	M460 CNTR, FLAT DUNNAGE METHOD	40-3/4 X 55 X 46-1/4	1,879	47	131	68
64	M460 CNTR, FLAT DUNNAGE METHOD (DECREASED-HEIGHT UNIT)	40-3/4 X 55 X 35-1/2	1,438	47	131	69
65	M460 CNTR, ROUTED DUNNAGE METHOD	40 X 55 X 45-7/8	1,875	48	131	70
66	M460 CNTR, ROUTED DUNNAGE METHOD (DECREASED-HEIGHT UNIT)	40 X 55 X 35-7/8	1,444	48	131	71
67	M460 CNTR, W/PROTECTIVE COVER	40 X 55 X 45-1/2	2,005	49	132	72
68	M460 CNTR, W/PROTECTIVE COVER (DECREASED-HEIGHT UNIT)	40 X 55 X 35-1/2	1,525	49	132	73
69	PA37 CNTR, ALTERNATED CONTAINERS	35-3/4 X 47-1/2 X 38-1/2	1,150	50	132	74
70	PA37 CNTR, ALTERNATED CONTAINERS (INCREASED-HEIGHT UNIT)	35-3/4 X 47-1/2 X 46-1/8	1,432	50	132	75
71	PA37 CNTR, FLAT DUNNAGE METHOD	35-3/4 X 52-1/2 X 49	1,452	51	132	76
72	PA37 CNTR, FLAT DUNNAGE METHOD (DECREASED-HEIGHT UNIT)	35-3/4 X 52-1/2 X 40-5/8	1,191	51	132	77
73	PA37 CNTR, ROUTED DUNNAGE METHOD	35-3/4 X 51 X 48-3/4	1,429	52	132	78
74	PA37 CNTR, ROUTED DUNNAGE METHOD (DECREASED-HEIGHT UNIT)	35-3/4 X 51 X 40-3/8	1,157	52	132	79
75	PA66 CNTR, ALTERNATED CONTAINER	37-3/4 X 50-1/2 X 35-5/8	1,273	53	132	80
76	PA66 CNTR, ALTERNATED CONTAINERS (INCREASED-HEIGHT UNIT)	37-3/4 X 50-1/2 X 45-3/8	1,677	53	132	81
77	PA66 CNTR, FLAT DUNNAGE METHOD	40-3/4 X 53-1/2 X 49	1,738	54	132	82
78	PA66 CNTR, FLAT DUNNAGE METHOD (DECREASED-HEIGHT UNIT)	40-3/4 X 53-1/2 X 38-1/2	1,322	54	132	83
79	PA66 CNTR, ROUTED DUNNAGE METHOD	40-3/4 X 52-1/2 X 48-1/2	1,736	55	133	84
80	PA66 CNTR, ROUTED DUNNAGE METHOD (DECREASED-HEIGHT UNIT)	40-3/4 X 52-1/2 X 37-7/8	1,337	55	133	85
81	PA68 CNTR, ALTERNATED CONTAINERS	38 X 48-1/2 X 36-3/4	1,333	56	133	86
82	PA68 CNTR, ALTERNATED CONTAINERS (INCREASED-HEIGHT UNIT)	38 X 48-1/2 X 44-3/8	1,652	56	133	87
83	PA68 CNTR, FLAT DUNNAGE METHOD	41 X 51-1/2 X 40-1/2	1,400	57	133	88
84	PA68 CNTR, FLAT DUNNAGE METHOD (INCREASED-HEIGHT UNIT)	41 X 51-1/2 X 48-7/8	1,726	57	133	89
85	PA68 CNTR, ROUTED DUNNAGE METHOD	41 X 50-1/2 X 40-3/8	1,385	58	133	90
86	PA68 CNTR, ROUTED DUNNAGE METHOD (INCREASED-HEIGHT UNIT)	41 X 50-1/2 X 48-3/4	1,704	58	133	91
87	PA75 CNTR, ALTERNATED CONTAINERS	35-1/4 X 45-1/2 X 41-1/2	1,238	59	133	92
88	PA75 CNTR, ALTERNATED CONTAINERS (INCREASED-HEIGHT UNIT)	35-1/4 X 45-1/2 X 48-1/2	1,475	59	133	93
89	PA75 CNTR, FLAT DUNNAGE METHOD	35-1/4 X 48-5/8 X 45-7/8	1,260	60	133	94
90	PA75 CNTR, FLAT DUNNAGE METHOD (DECREASED-HEIGHT UNIT)	35-1/4 X 45-5/8 X 38-1/8	1,026	60	133	95
91	PA75 CNTR, ROUTED DUNNAGE METHOD	35-1/4 X 46-3/4 X 45-5/8	1,260	61	134	96
92	PA75 CNTR, ROUTED DUNNAGE METHOD (DECREASED-HEIGHT UNIT)	35-1/4 X 46-3/4 X 37-3/4	1,033	61	134	97
93	PA91 CNTR, PALLET UNIT	36 X 47-3/4 X 51-1/4	2,025	62	134	98
94	PA91 CNTR, PALLET UNIT (DECREASED-HEIGHT)	36 X 47-3/4 X 43-3/4	1,597	62	134	99
95	PA92 CNTR, PALLET UNIT	36-5/8 X 48-3/4 X 52-1/2	1,930	63	134	100
96	PA92 CNTR, PALLET UNIT (DECREASED-HEIGHT)	36-5/8 X 48-3/4 X 43-1/4	1,558	63	134	101

* THE PALLET UNITS LISTED ON THE EVEN NUMBERED LINES 32 THRU 96 ARE ALTERNATIVE HEIGHT UNITS, EITHER INCREASED HEIGHT OR DECREASED HEIGHT, AS PERMITTED BY THE UNITIZATION DRAWINGS FOR EACH ITEM CONTAINER MODEL.

(CONTINUED ON PAGE 138)

DO NOT WRITE (STAMP) ON THIS PAGE

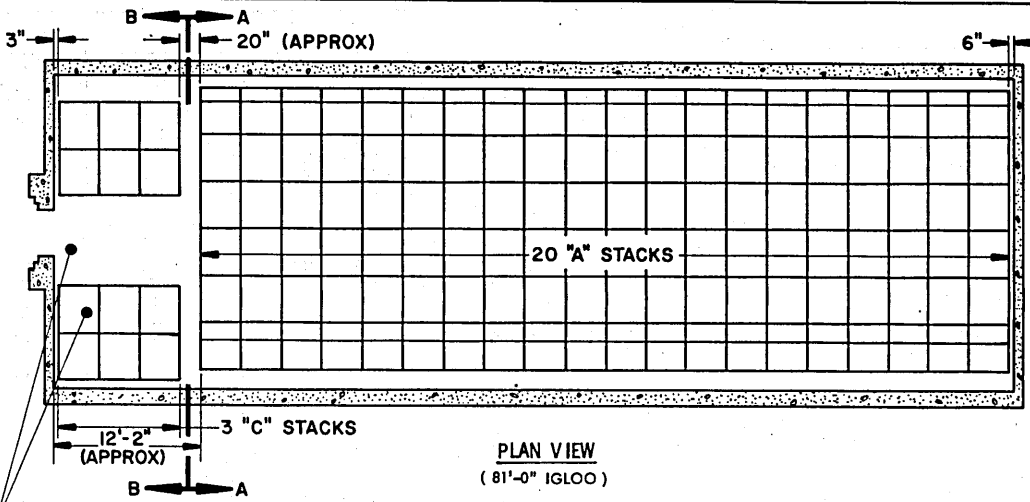

STORAGE IN 81'-0" IGLOO

ITEM	QUANTITY
PALLET UNITS	321

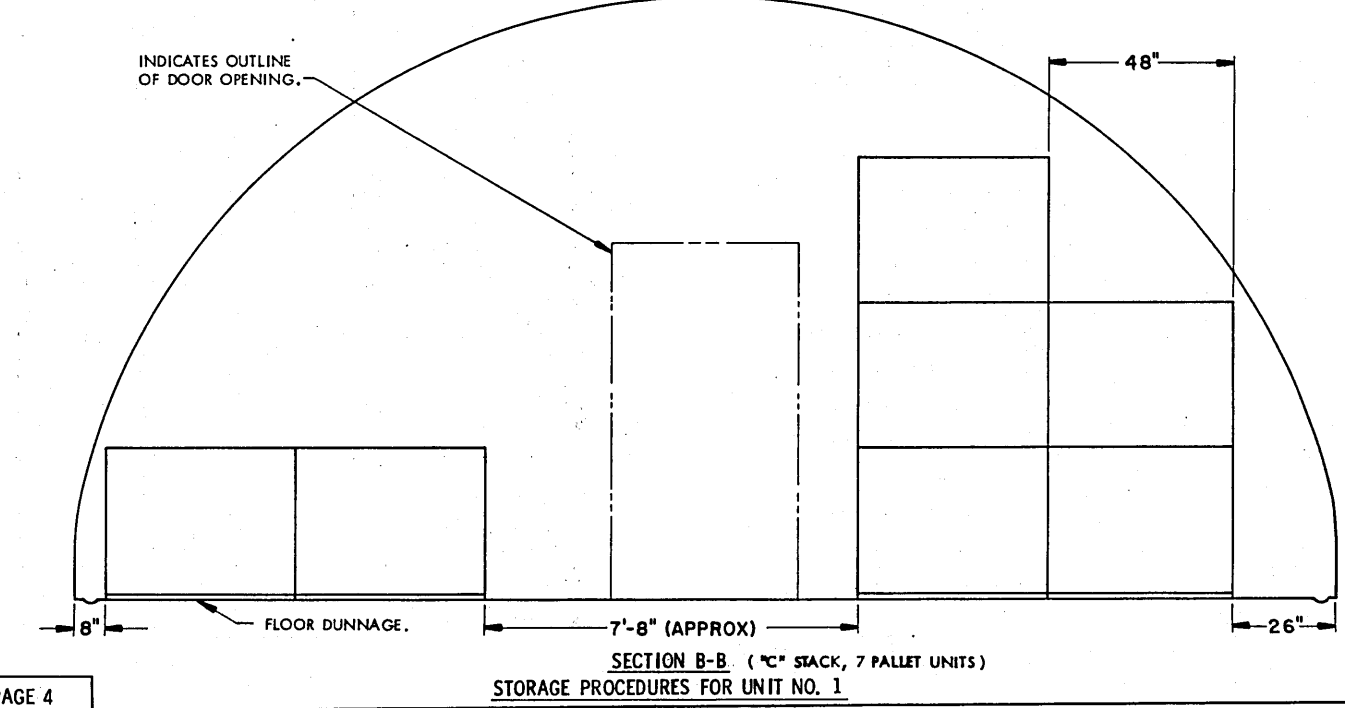
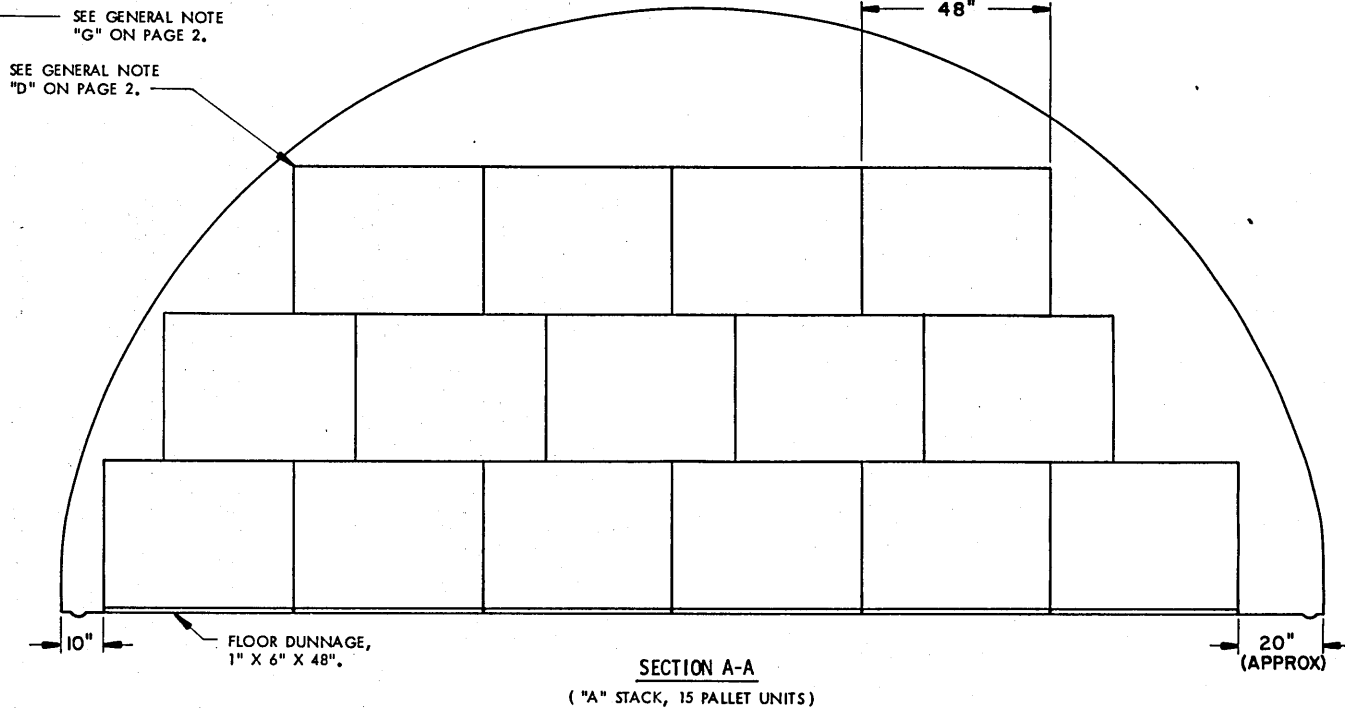

STORAGE IN 60'-8" IGLOO

ITEM QUANTITY
 PALLET UNITS ----- 231

*** STORAGE IN 40'-4" IGLOO**

ITEM QUANTITY
 PALLET UNITS ----- 141

* 8 A-STACKS
 3 C-STACKS

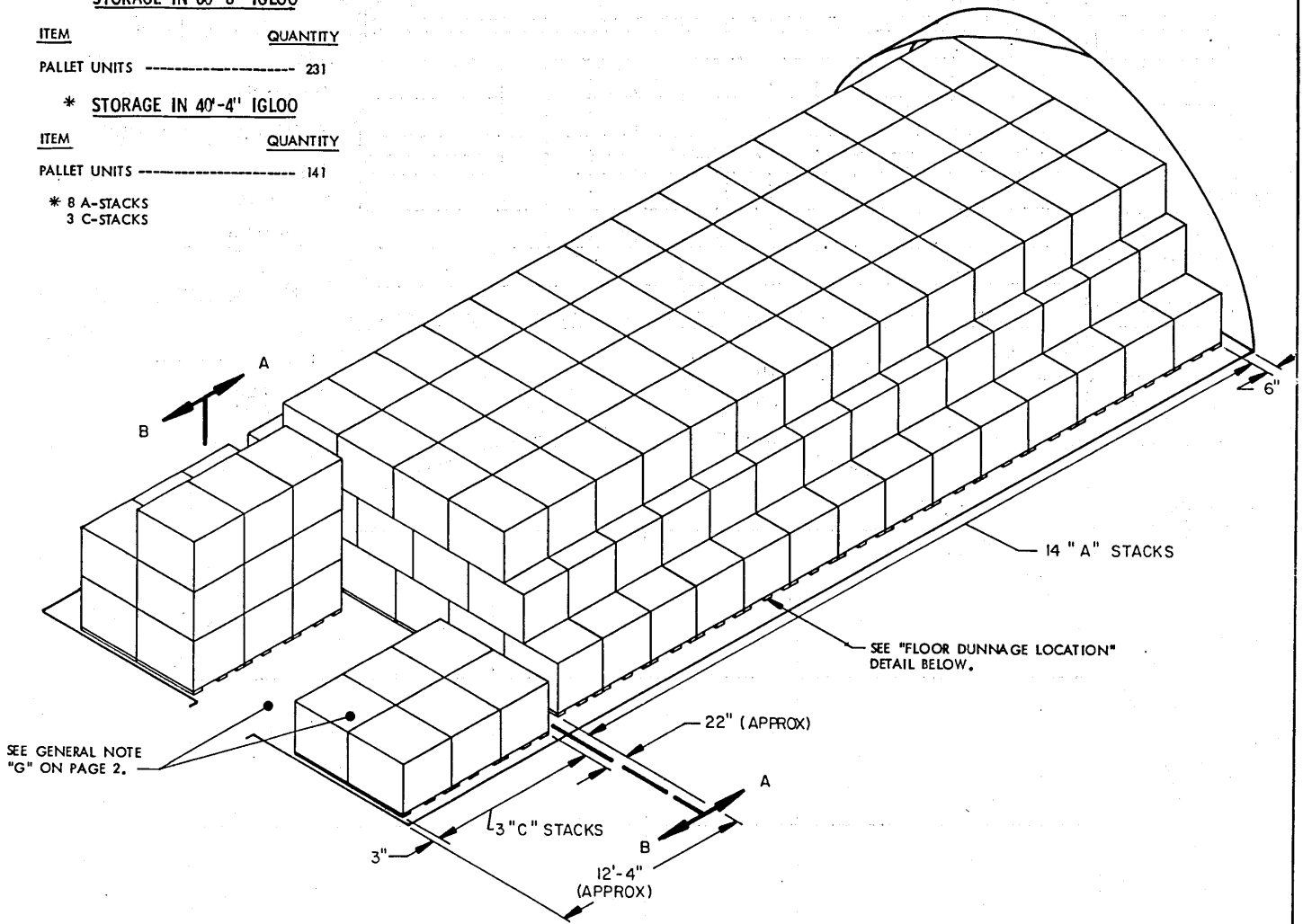

ISOMETRIC VIEW

(60'-8" IGLOO)

FOR "GENERAL NOTES" AND "MATERIAL SPECIFICATIONS",
 SEE PAGE 2.

**** BILL OF MATERIAL (PER FIRST LAYER PALLET UNIT)**

LUMBER	LINEAR FEET	BOARD FEET
1" X 6" X 42"	10,50	5,22
1" X 6" X 48"	12,00	6,00

** SEE GENERAL NOTES "F" AND "J" ON PAGE 2.

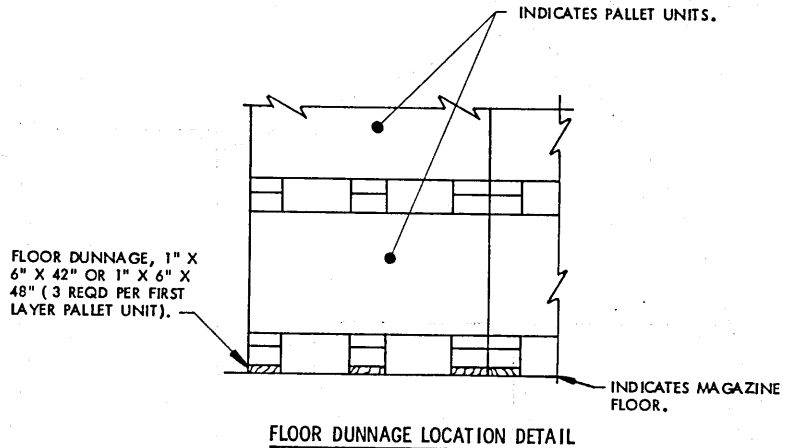

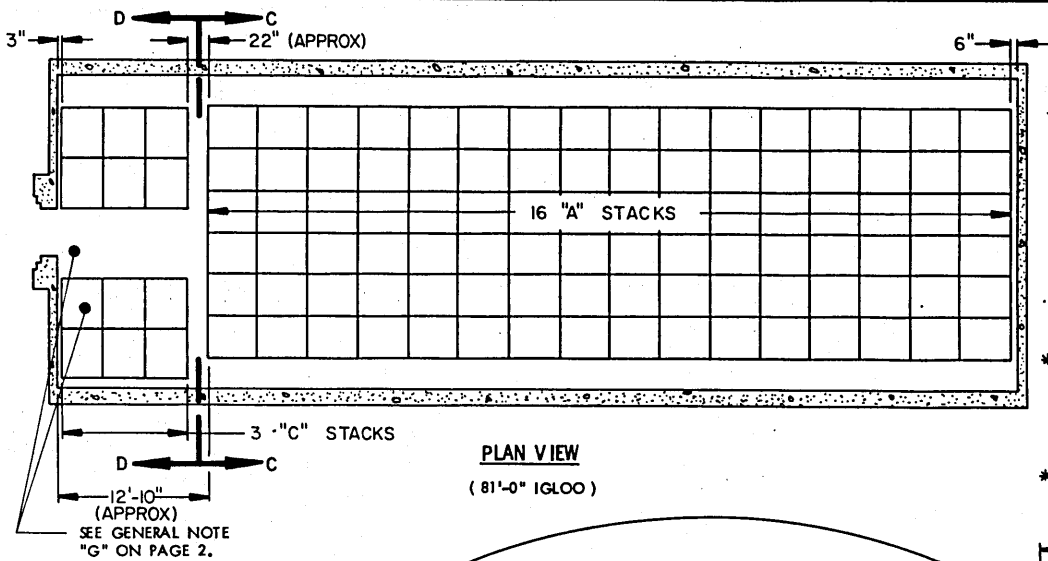

PLAN VIEW
(81'-0" IGLOO)

STORAGE IN 81'-0" IGLOO	
ITEM	QUANTITY
PALLET UNITS	277
* STORAGE IN 60'-8" IGLOO	
ITEM	QUANTITY
PALLET UNITS	197
* 11 A-STACKS	
3 C-STACKS	
** STORAGE IN 40'-4" IGLOO	
ITEM	QUANTITY
PALLET UNITS	117
* 6 A-STACKS	
3 C-STACKS	

SEE GENERAL NOTE "D" ON PAGE 2.

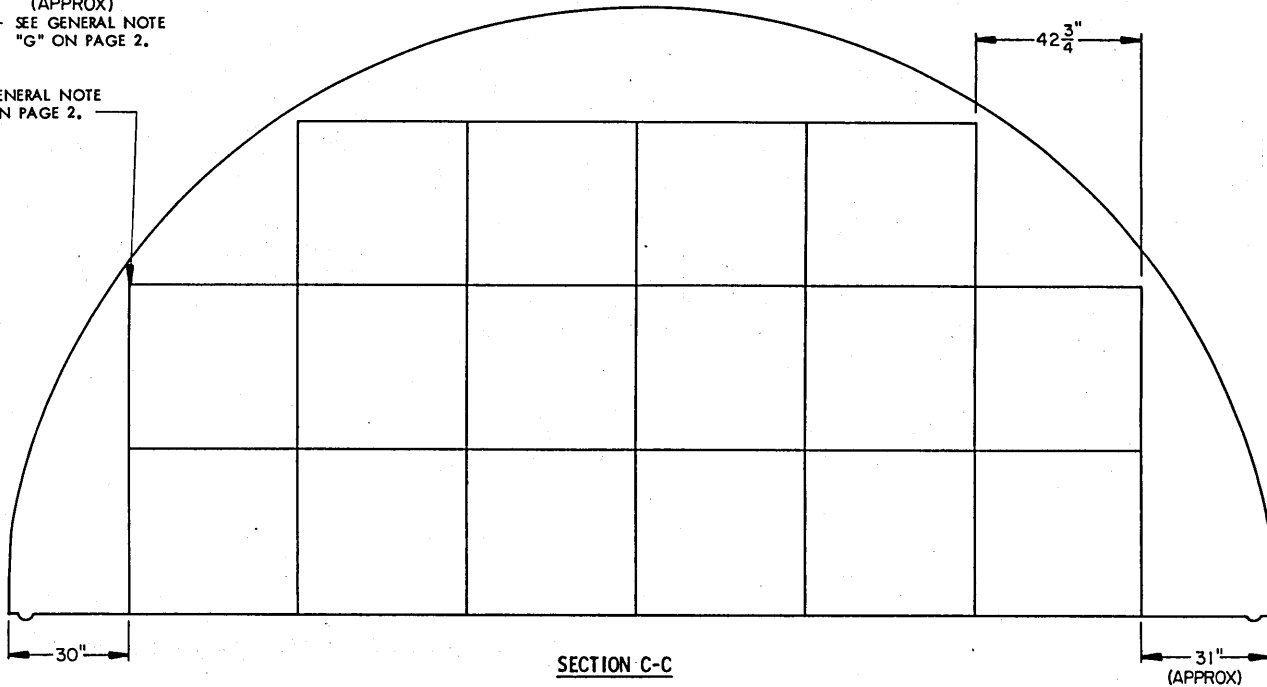

SECTION C-C
("A" STACK, 16 PALLET UNITS)

INDICATES OUTLINE OF DOOR OPENING.

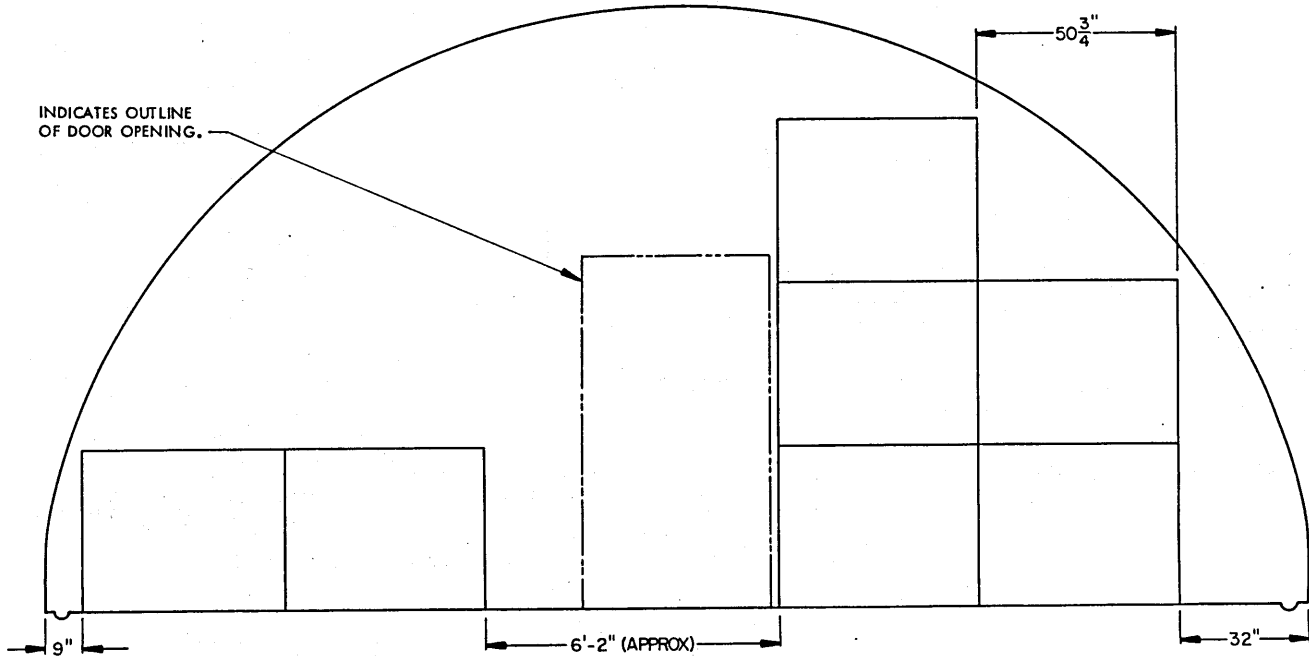

SECTION D-D ("C" STACK, 7 PALLET UNITS)
STORAGE PROCEDURES FOR UNIT NO. 2

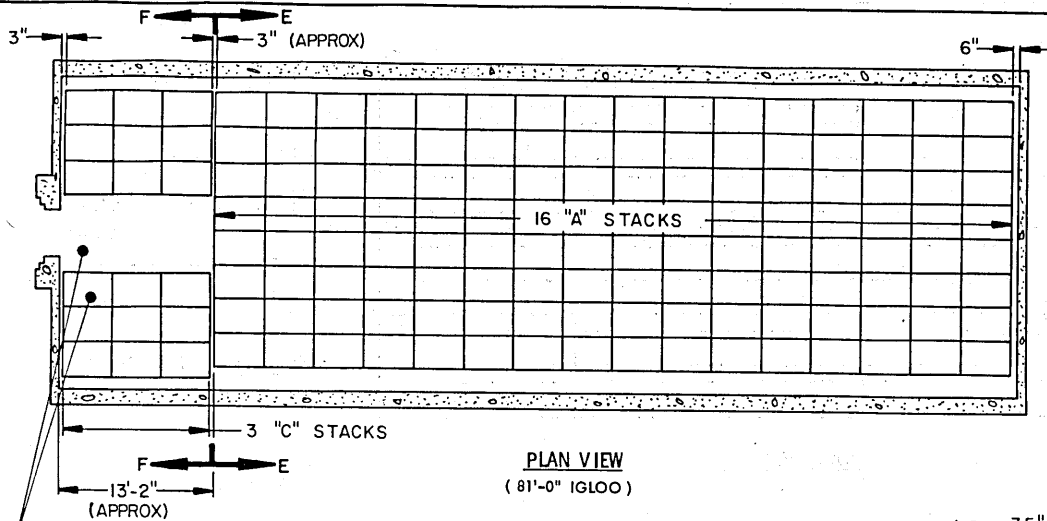

STORAGE IN 81'-0" IGLOO	
ITEM	QUANTITY
PALLET UNITS	248
* STORAGE IN 60'-8" IGLOO	
ITEM	QUANTITY
PALLET UNITS	178
* 11 A-STACKS	
3 C-STACKS	
** STORAGE IN 40'-4" IGLOO	
ITEM	QUANTITY
PALLET UNITS	108
** 6 A-STACKS	
3 C-STACKS	

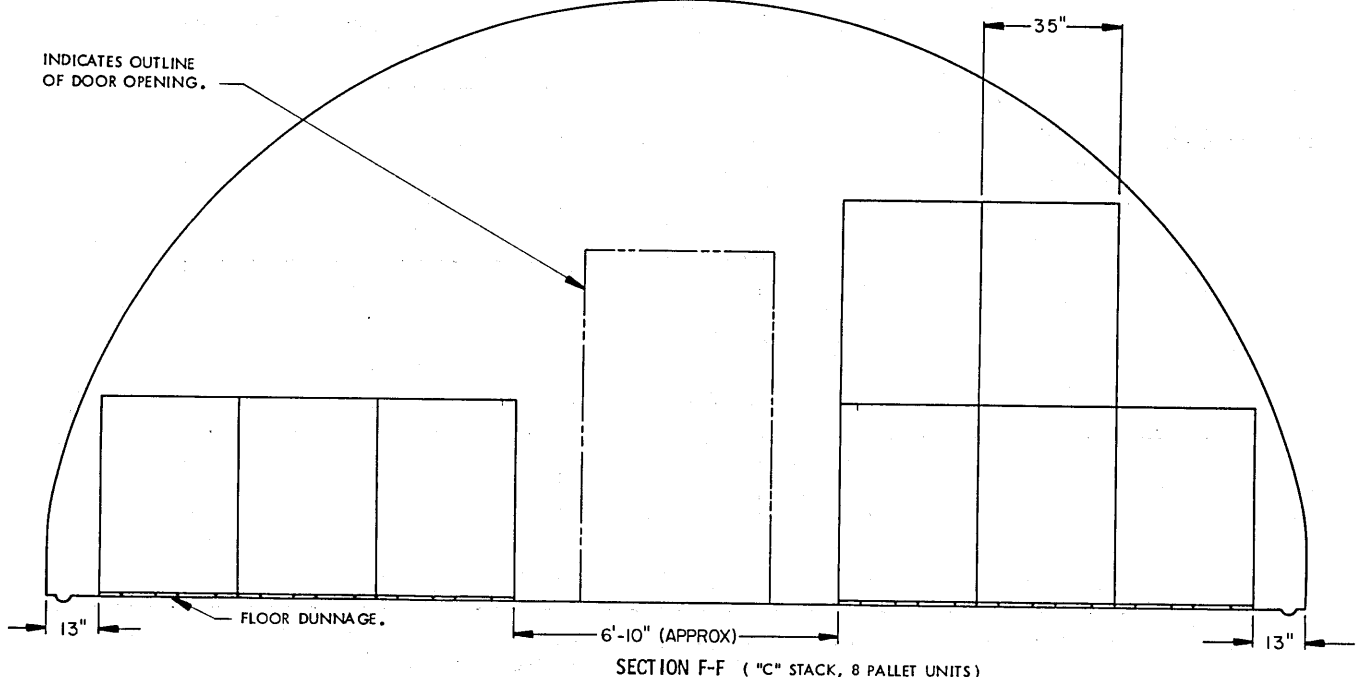
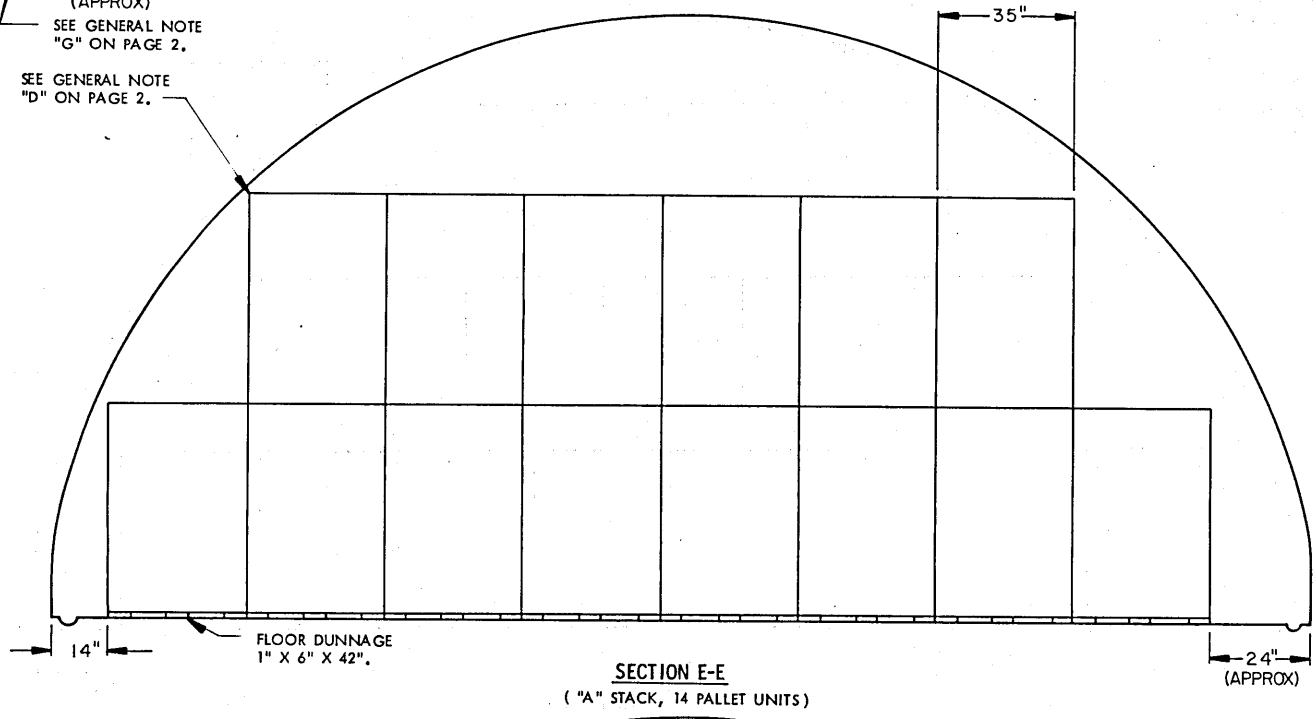

STORAGE PROCEDURES FOR UNIT NO. 3

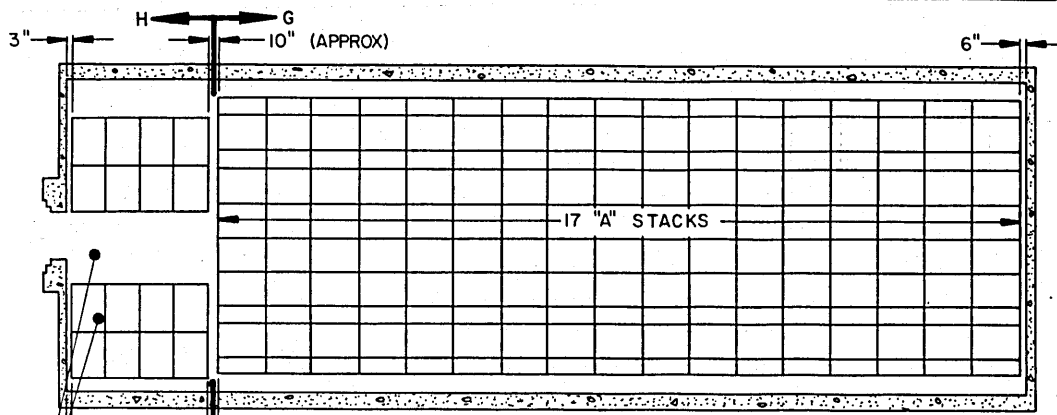

PLAN VIEW
(81'-0" IGLOO)

STORAGE IN 81'-0" IGLOO	
ITEM	QUANTITY
PALLET UNITS	351
* STORAGE IN 60'-8" IGLOO	
ITEM	QUANTITY
PALLET UNITS	256
* 12 A-STACKS	
4 C-STACKS	
** STORAGE IN 40'-4" IGLOO	
ITEM	QUANTITY
PALLET UNITS	161
* 7 A-STACKS	
4 C-STACKS	

SEE SPECIAL NOTE "G" ON PAGE 2.

SEE SPECIAL NOTE "D" ON PAGE 2.

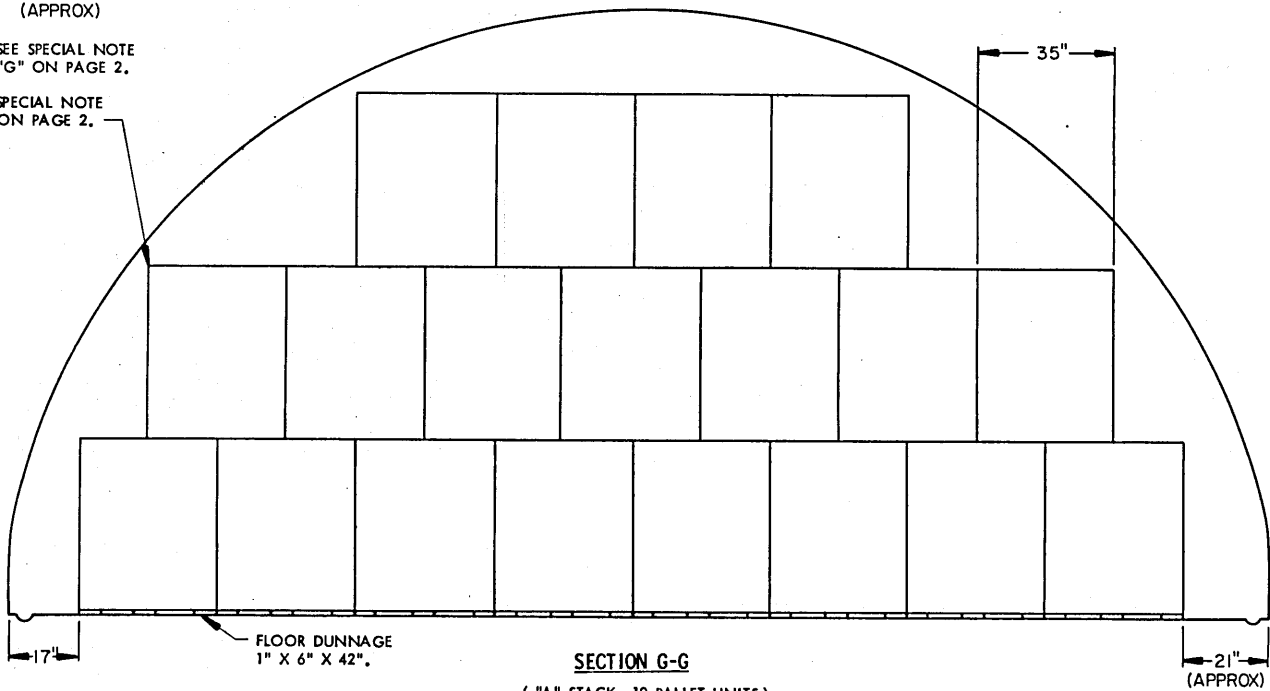

SECTION G-G
("A" STACK, 19 PALLET UNITS)

INDICATES OUTLINE OF DOOR OPENING.

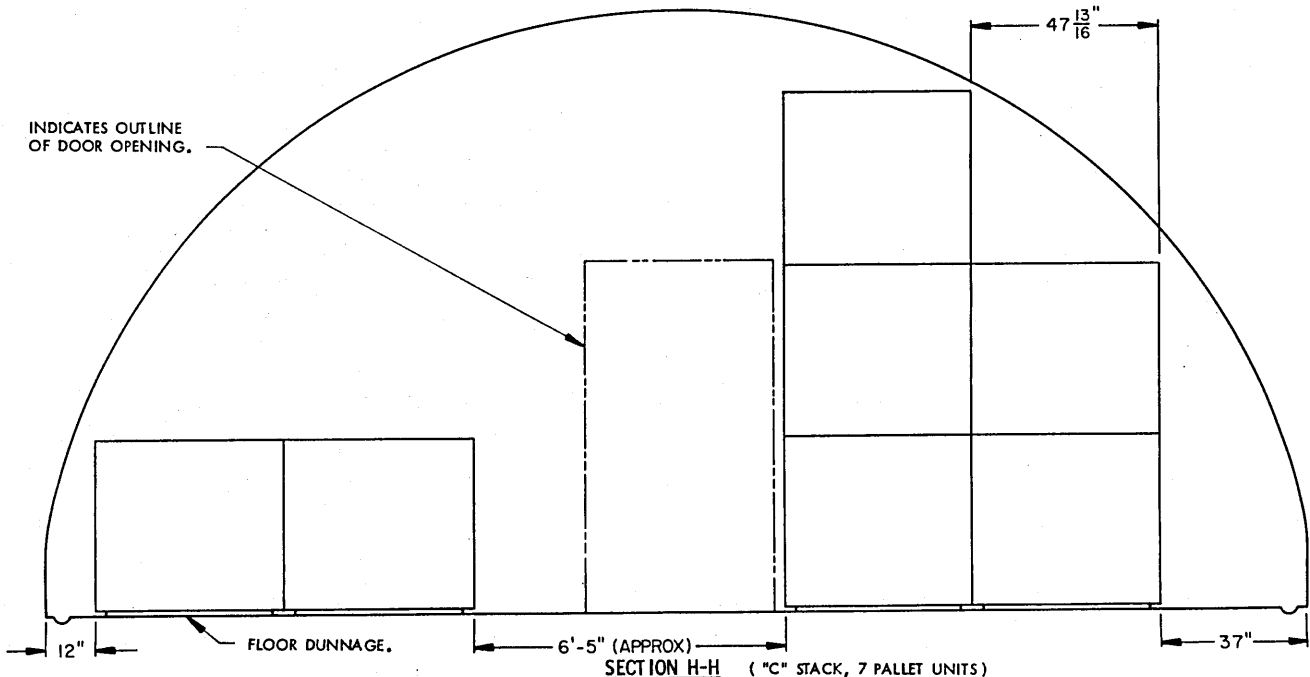

SECTION H-H ("C" STACK, 7 PALLET UNITS)

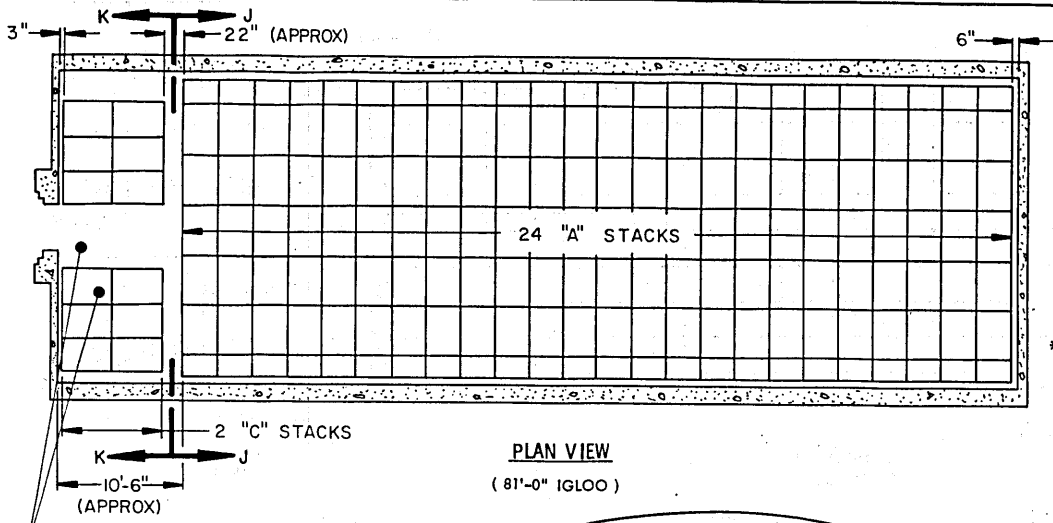

STORAGE IN 81'-0" IGLOO

ITEM	QUANTITY
PALLET UNITS	358

*** STORAGE IN 60'-8" IGLOO**

ITEM	QUANTITY
PALLET UNITS	260
* 17 A-STACKS	
2 C-STACKS	

**** STORAGE IN 40'-4" IGLOO**

ITEM	QUANTITY
PALLET UNITS	162
** 10 A-STACKS	
2 C-STACKS	

PLAN VIEW
(81'-0" IGLOO)

SEE GENERAL NOTE "G" ON PAGE 2.

SEE GENERAL NOTE "D" ON PAGE 2.

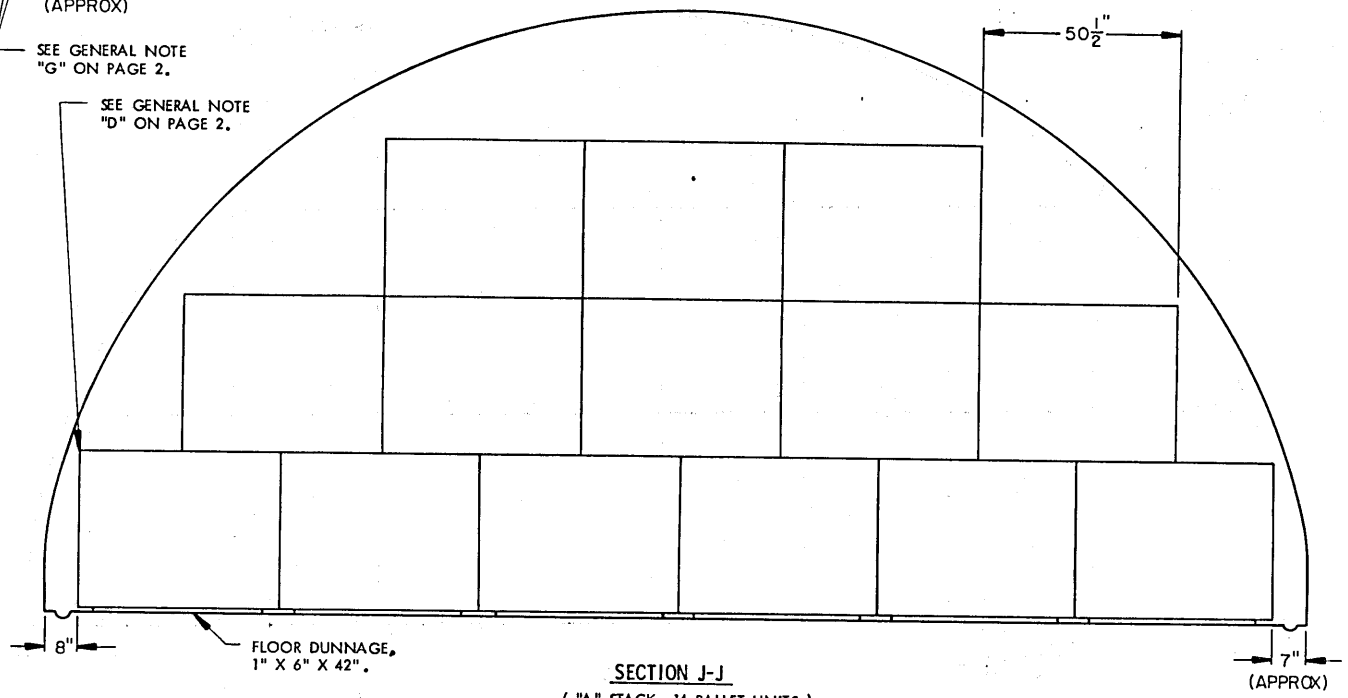

SECTION J-J
("A" STACK, 14 PALLET UNITS.)

INDICATES OUTLINE OF DOOR OPENING.

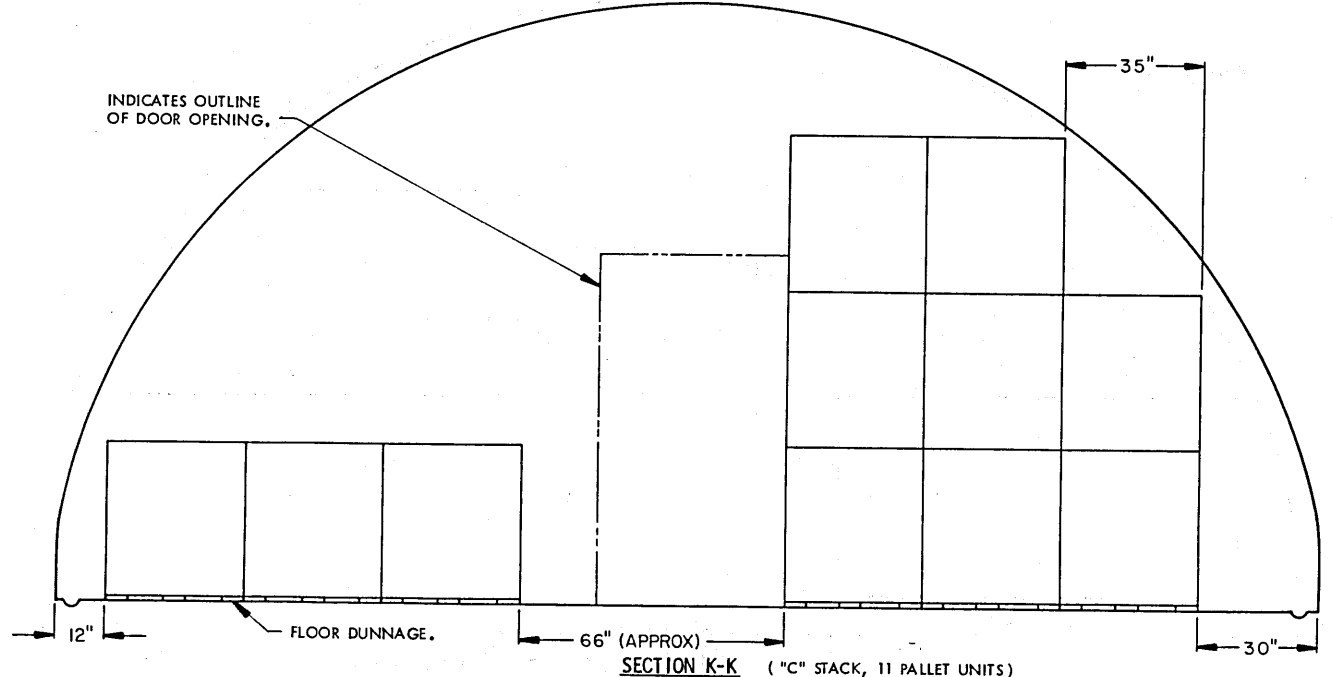

SECTION K-K ("C" STACK, 11 PALLET UNITS)

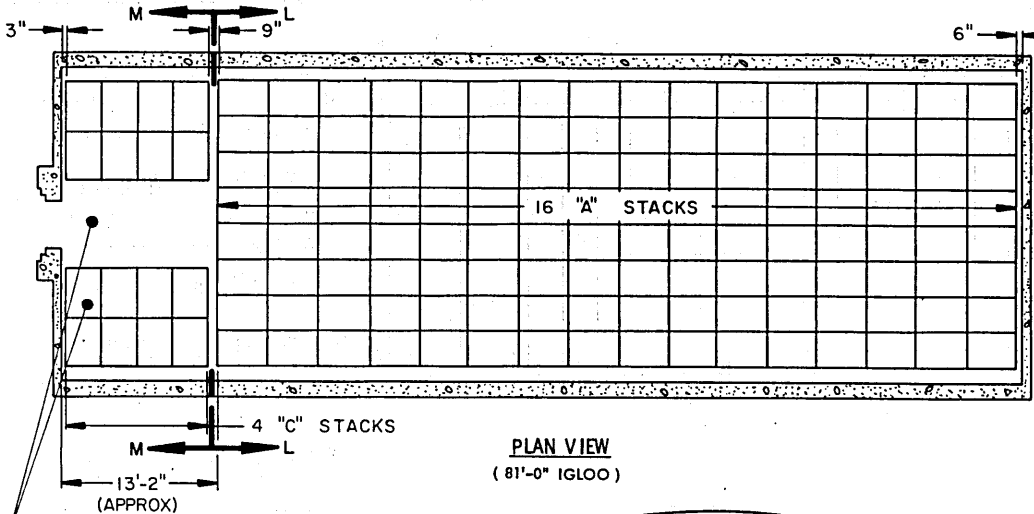

PLAN VIEW
(81'-0" IGLOO)

STORAGE IN 81'-0" IGLOO	
ITEM	QUANTITY
PALLET UNITS	244
* STORAGE IN 60'-8" IGLOO	
ITEM	QUANTITY
PALLET UNITS	174
* 11 A-STACKS	
4 C-STACKS	
** STORAGE IN 40'-4" IGLOO	
ITEM	QUANTITY
PALLET UNITS	113
** 7 A-STACKS	
3 C-STACKS	

SEE GENERAL NOTE "G" ON PAGE 2.
SEE GENERAL NOTE "D" ON PAGE 2.

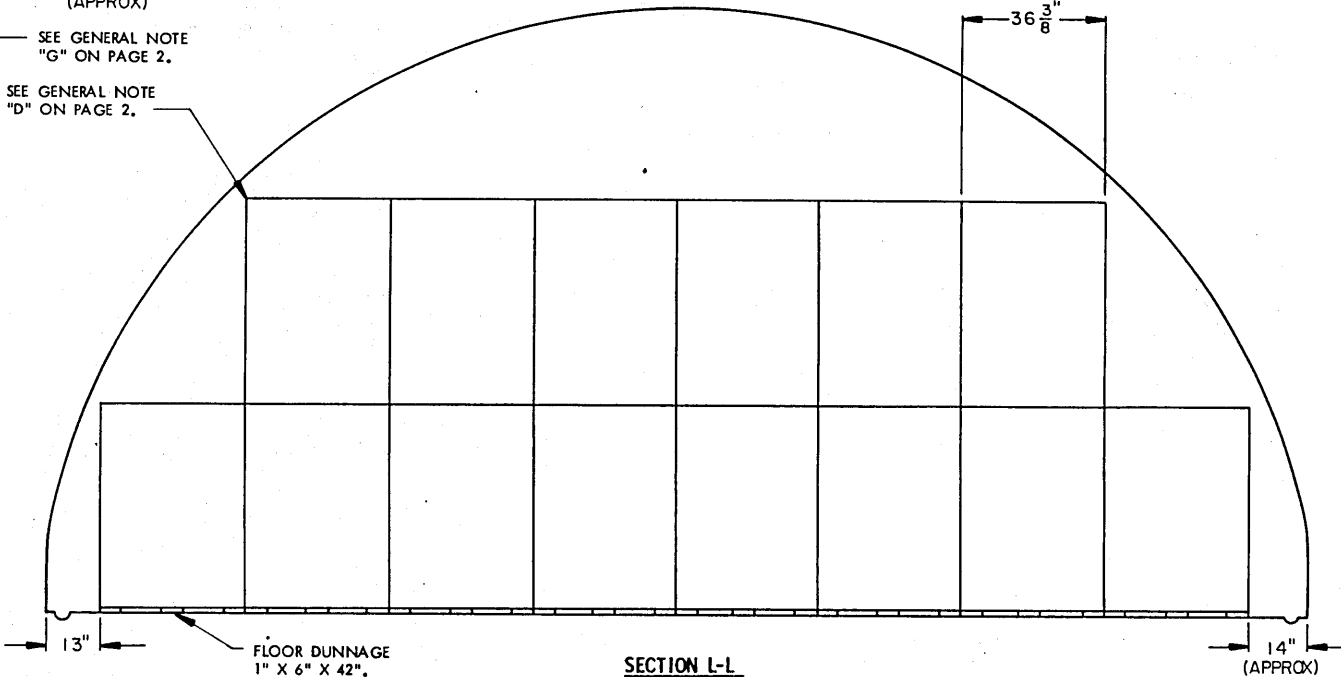

SECTION L-L
("A" STACK, 14 PALLET UNITS)

INDICATES OUTLINE OF DOOR OPENING.

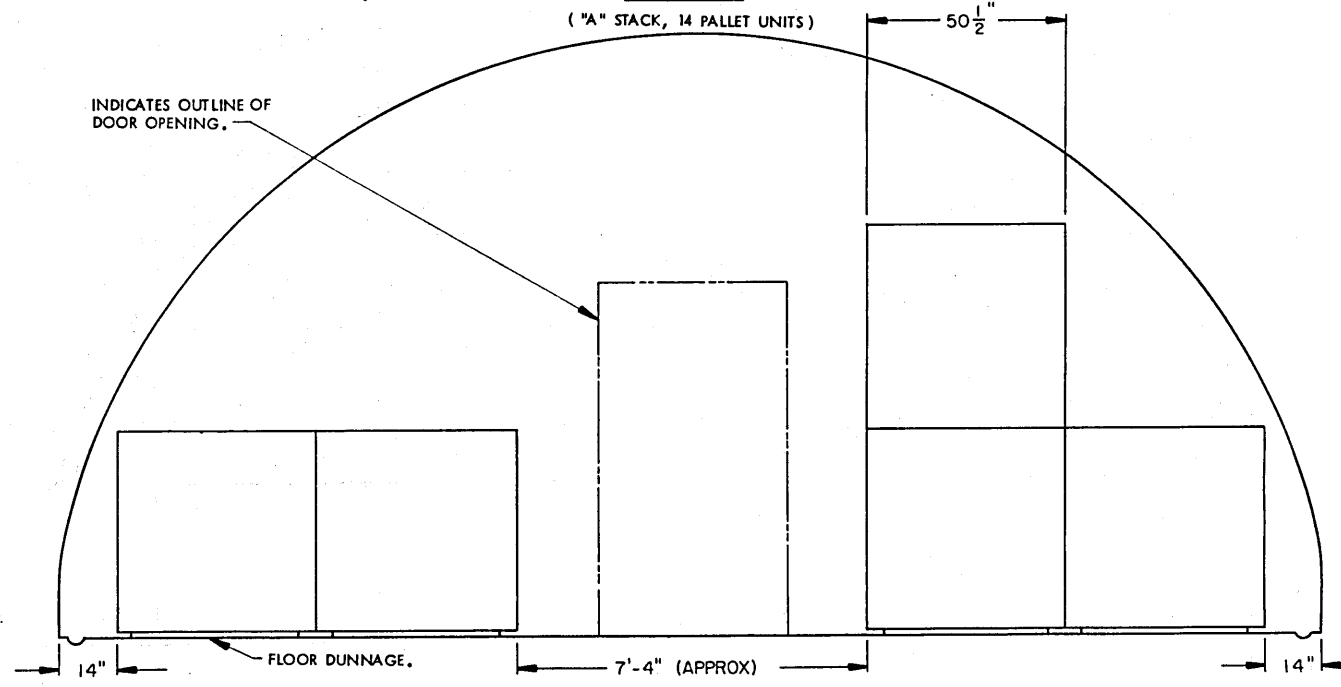

SECTION M-M ("C" STACK, 5 PALLET UNITS)

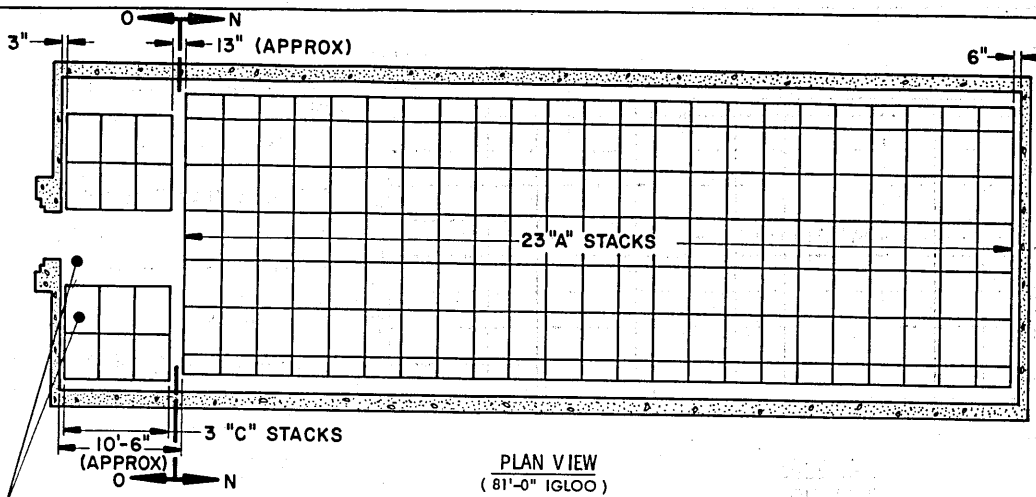

STORAGE IN 81'-0" IGLOO

ITEM	QUANTITY
PALLET UNITS	343

*** STORAGE IN 60'-8" IGLOO**

ITEM	QUANTITY
PALLET UNITS	245
* 16 A-STACKS	
3 C-STACKS	

**** STORAGE IN 40'-4" IGLOO**

ITEM	QUANTITY
PALLET UNITS	147
* 9 A-STACKS	
3 C-STACKS	

SEE GENERAL NOTE "G" ON PAGE 2.

SEE GENERAL NOTE "D" ON PAGE 2.

PLAN VIEW
(81'-0" IGLOO)

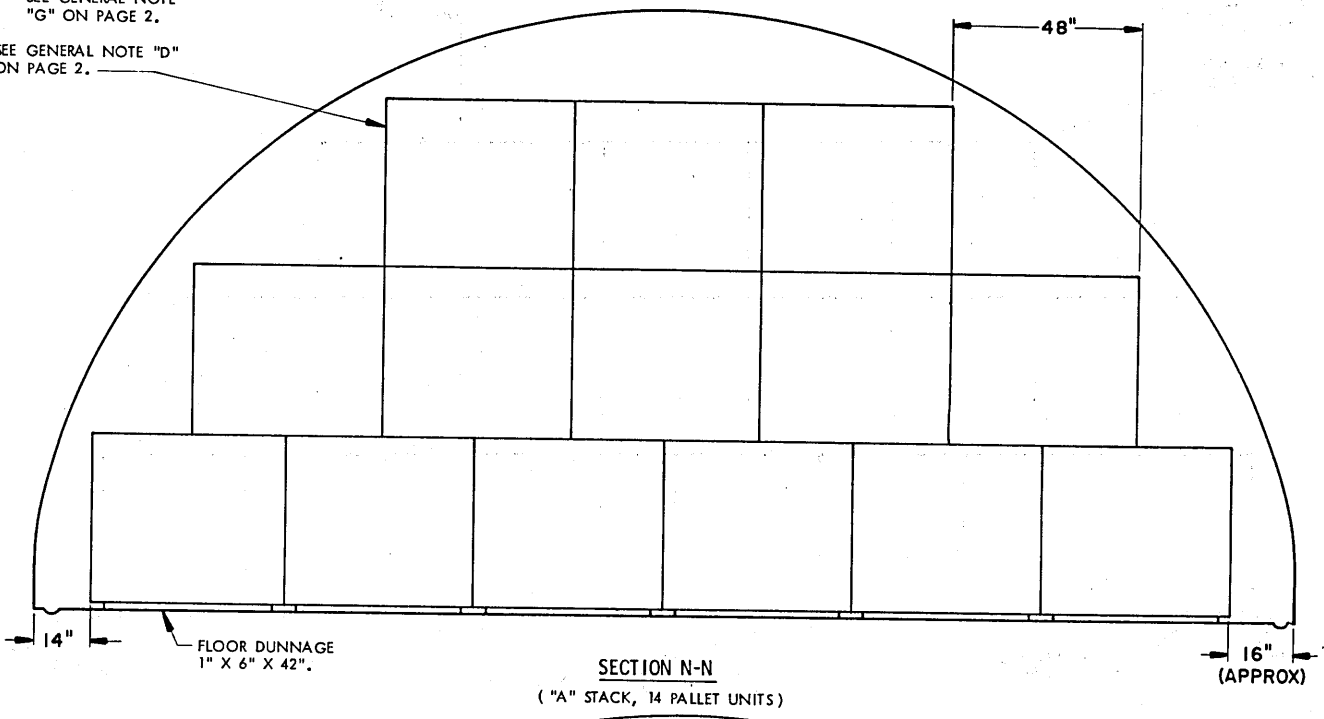

SECTION N-N
("A" STACK, 14 PALLET UNITS)

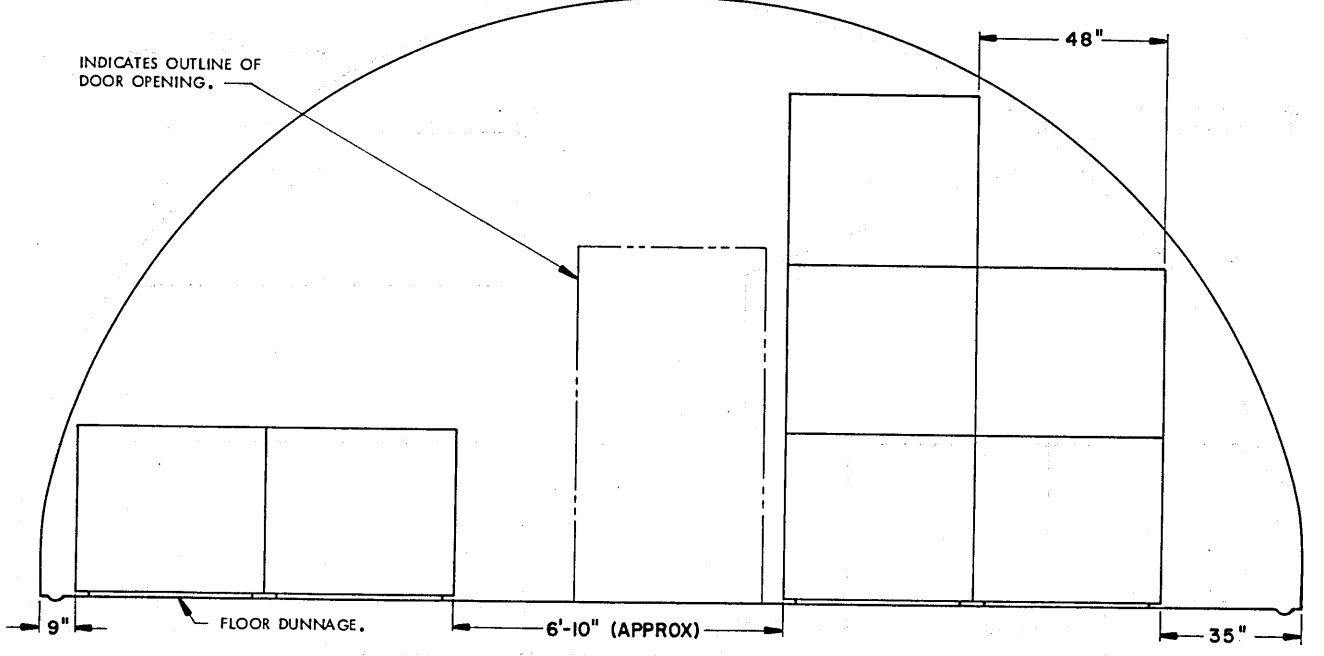

INDICATES OUTLINE OF DOOR OPENING.

SECTION O-O ("C" STACK, 7 PALLET UNITS)
STORAGE PROCEDURES FOR UNIT NO. 7

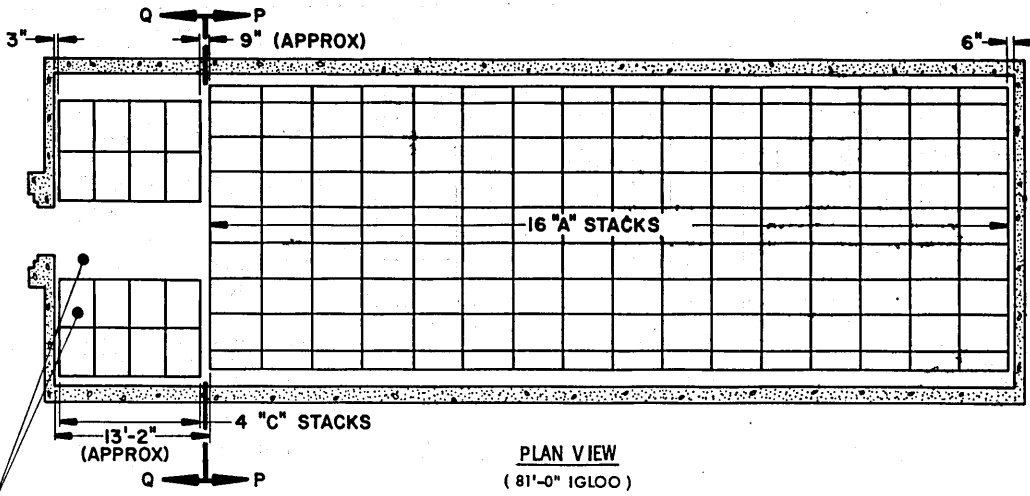

PLAN VIEW
(81'-0" IGLOO)

STORAGE IN 81'-0" IGLOO	
ITEM	QUANTITY
PALLET UNITS	348
* STORAGE IN 60'-8" IGLOO	
ITEM	QUANTITY
PALLET UNITS	248
* 11 A-STACKS	
4 C-STACKS	
** STORAGE IN 40'-4" IGLOO	
ITEM	QUANTITY
PALLET UNITS	148
** 6 A-STACKS	
4 C-STACKS	

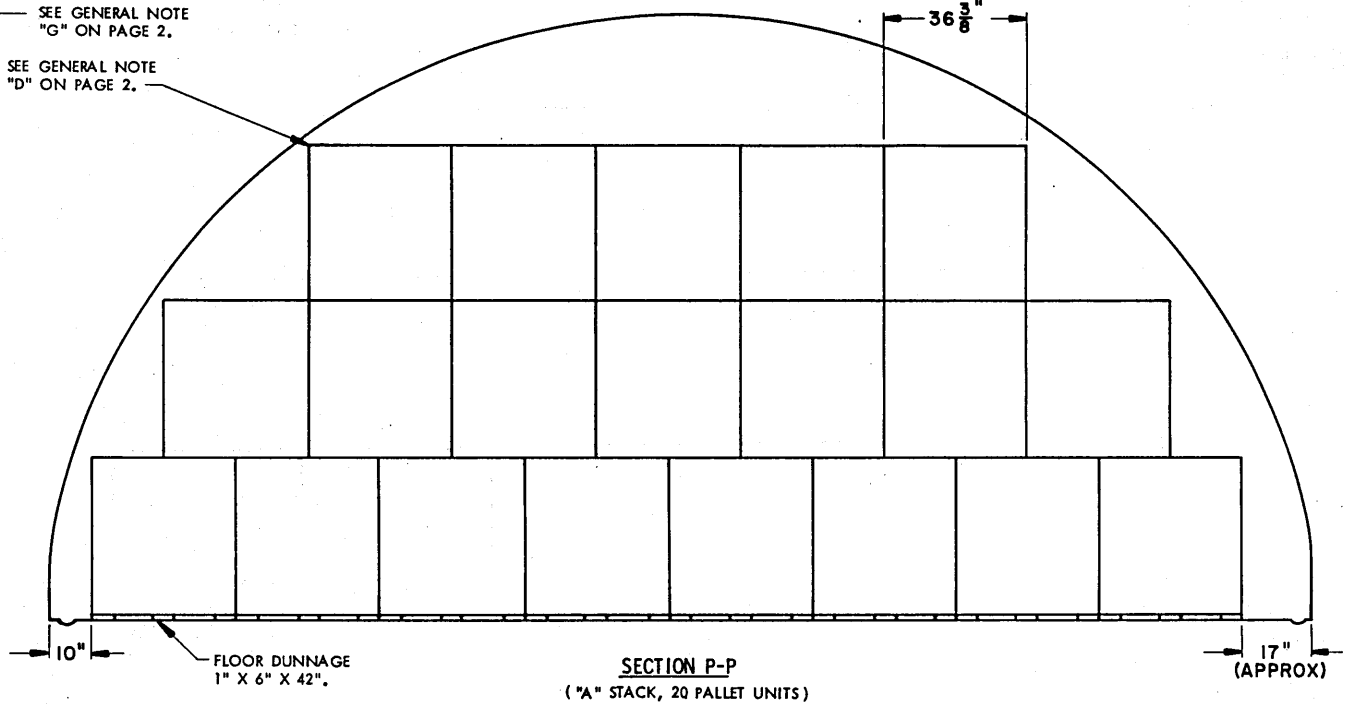

SECTION P-P
("A" STACK, 20 PALLET UNITS)

INDICATES OUTLINE OF DOOR OPENING.

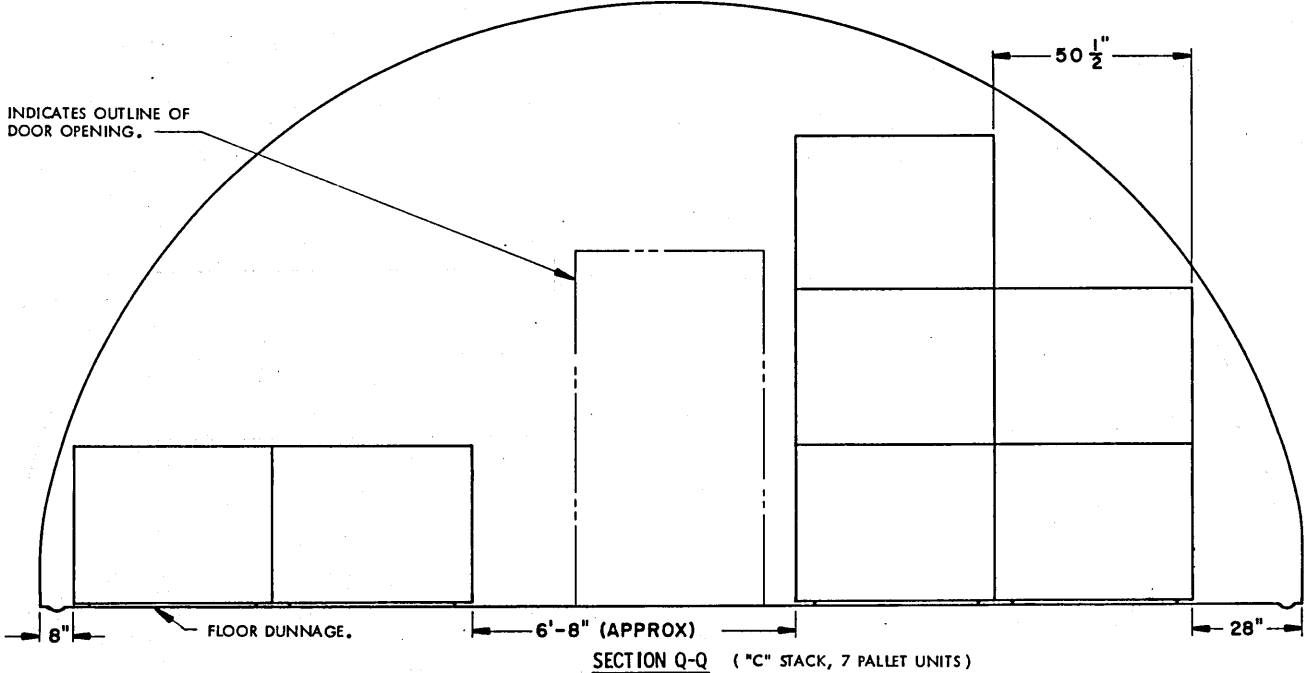

SECTION Q-Q ("C" STACK, 7 PALLET UNITS)

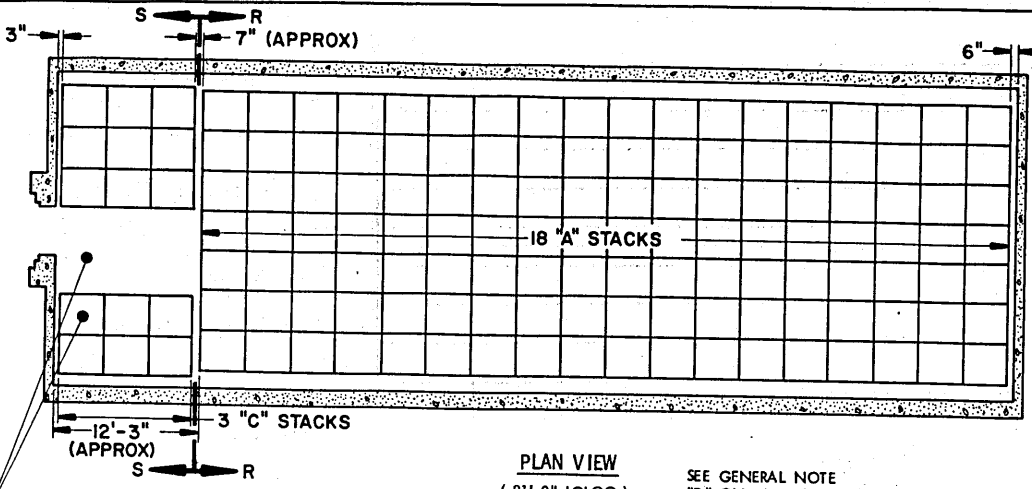

STORAGE IN 81'-0" IGLOO	
ITEM	QUANTITY
PALLET UNITS	255
* STORAGE IN 60'-8" IGLOO	
ITEM	QUANTITY
PALLET UNITS	183
* 13 A-STACKS 2 C-STACKS	
** STORAGE IN 40'-4" IGLOO	
ITEM	QUANTITY
PALLET UNITS	112
** 7 A-STACKS 3 C-STACKS	

PLAN VIEW
(81'-0" IGLOO)

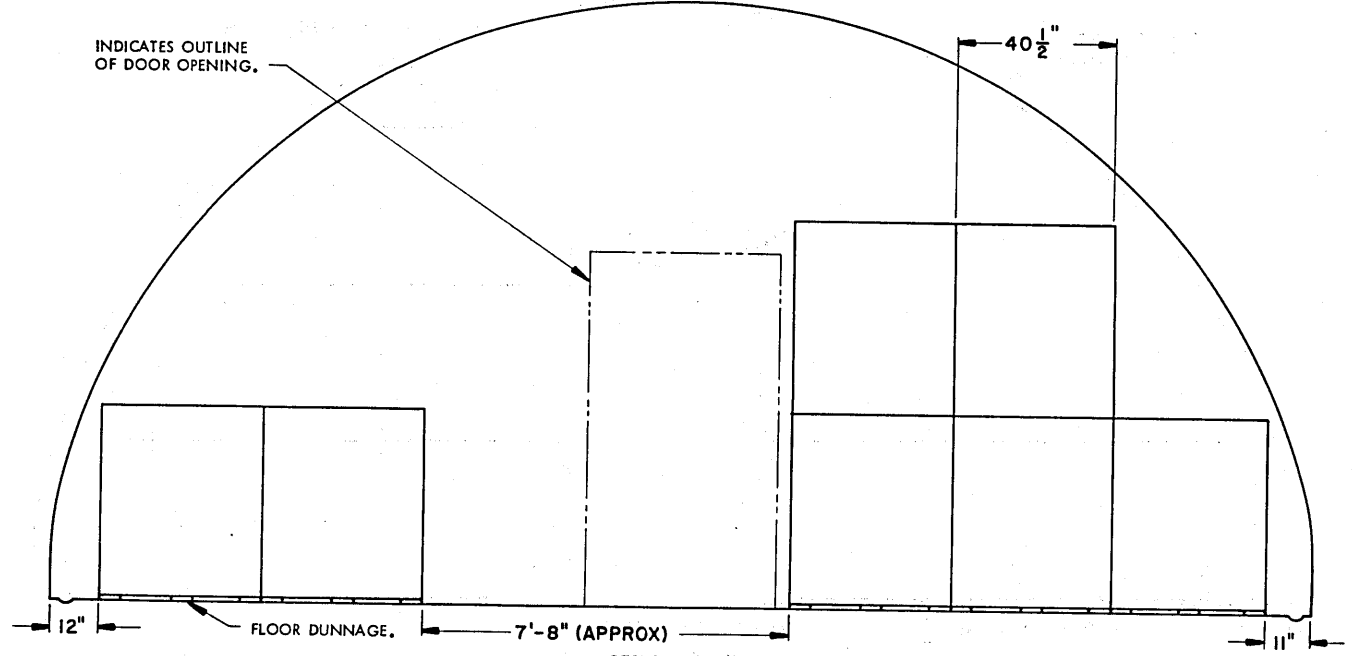
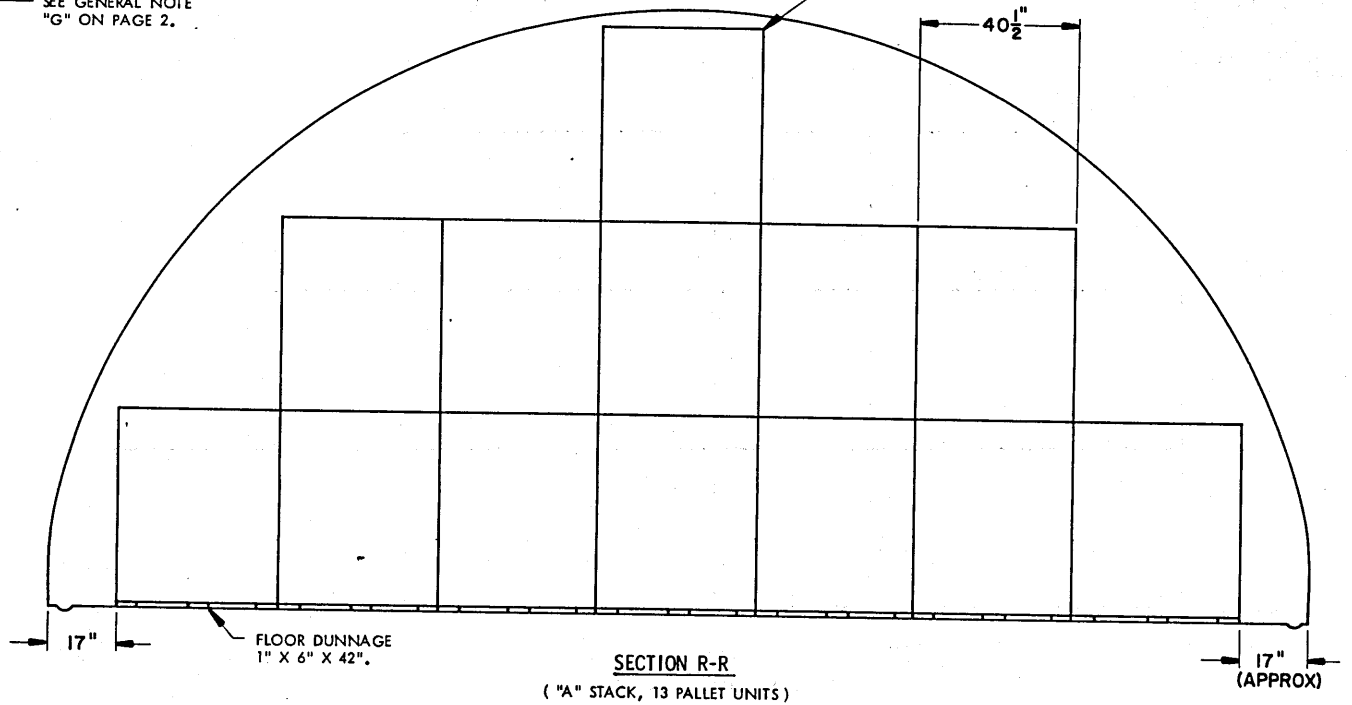

SECTION S-S ("C" STACK, 7 PALLET UNITS)
STORAGE PROCEDURES FOR UNIT NO. 9

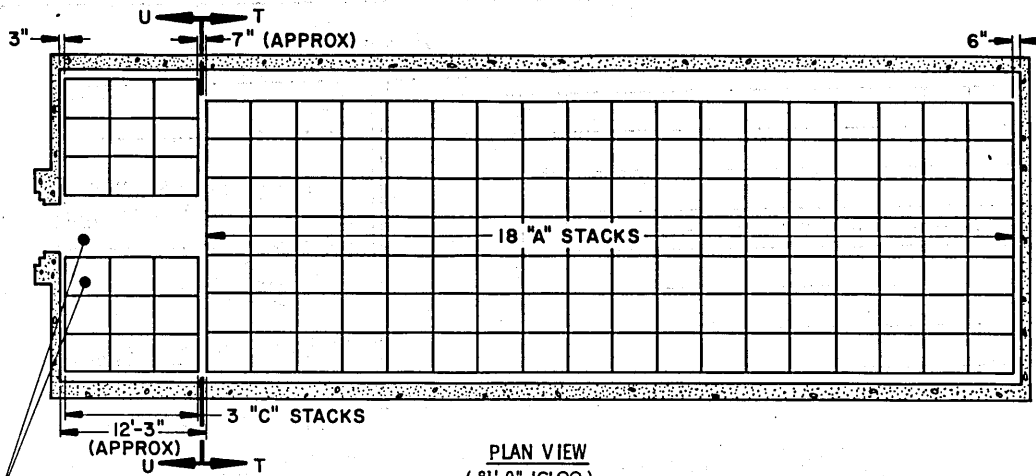

PLAN VIEW
(81'-0" IGLOO)

STORAGE IN 81'-0" IGLOO	
ITEM	QUANTITY
PALLET UNITS	333
* STORAGE IN 60'-8" IGLOO	
ITEM	QUANTITY
PALLET UNITS	239
* 13 A-STACKS	
2 C-STACKS	
** STORAGE IN 40'-4" IGLOO	
ITEM	QUANTITY
PALLET UNITS	146
** 7 A-STACKS	
3 C-STACKS	

SEE GENERAL NOTE "G" ON PAGE 2.

SEE GENERAL NOTE "D" ON PAGE 2.

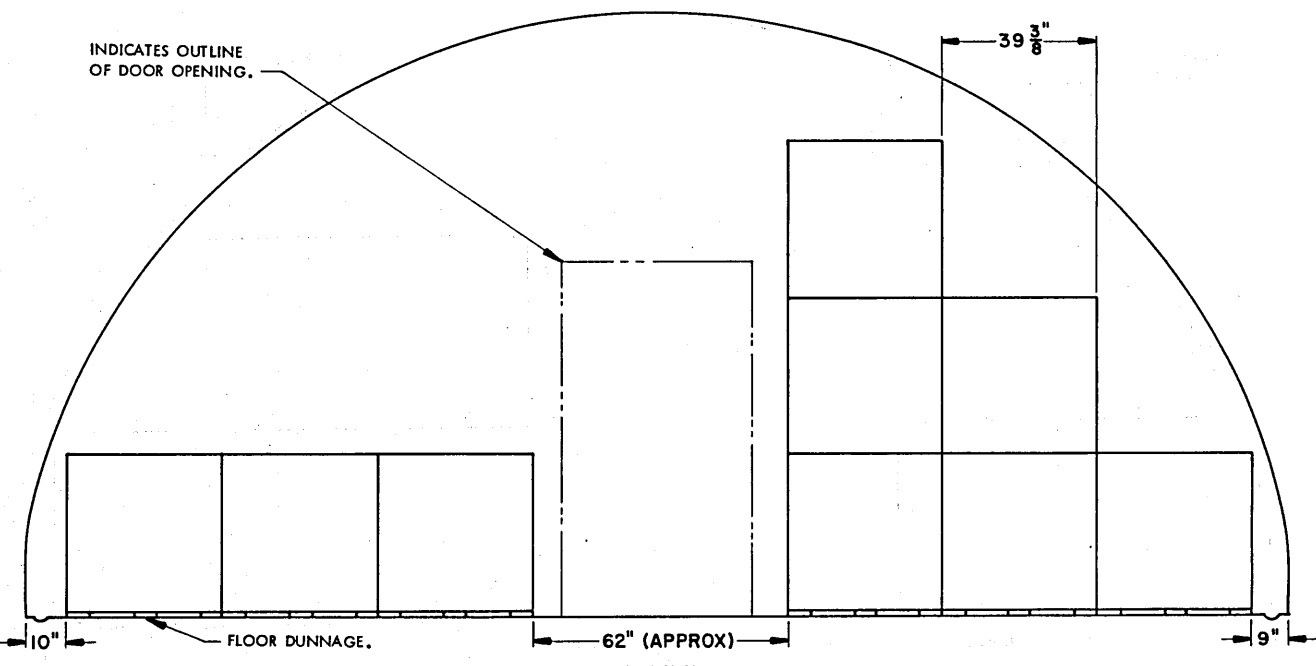
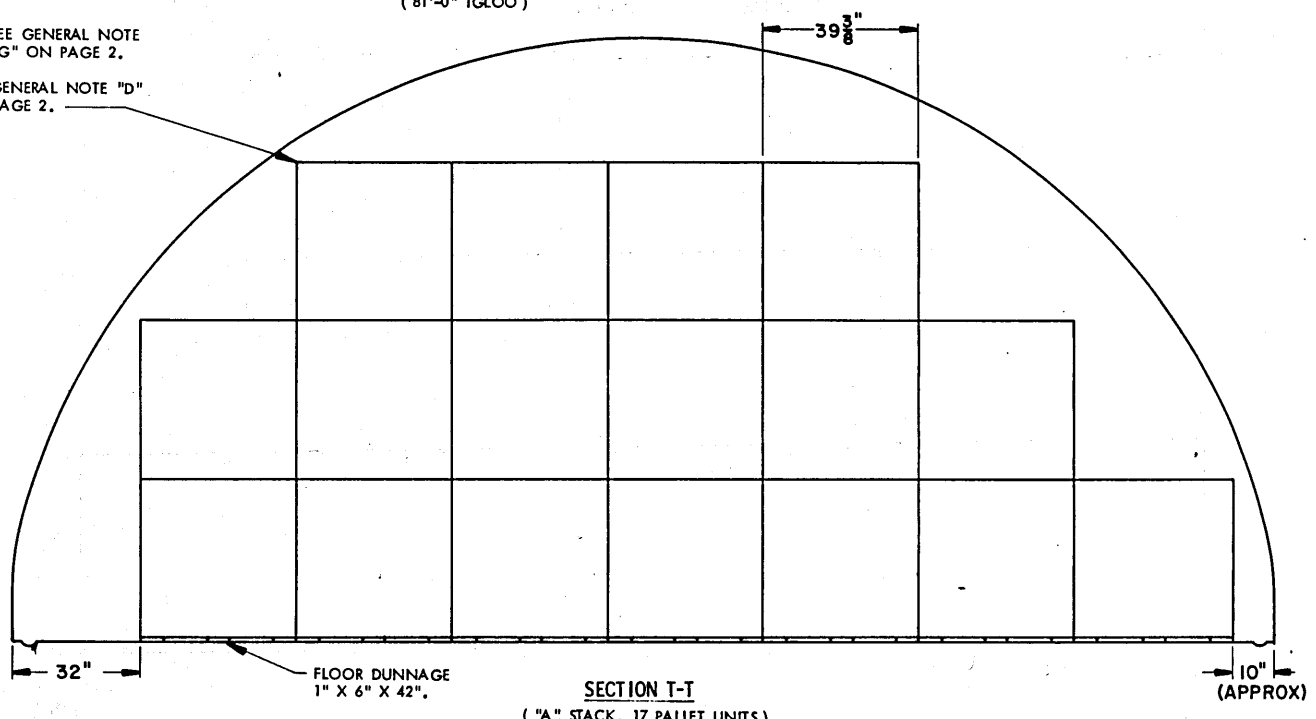

SECTION U-U ("C" STACK, 9 PALLET UNITS)

STORAGE PROCEDURES FOR UNIT NO. 10

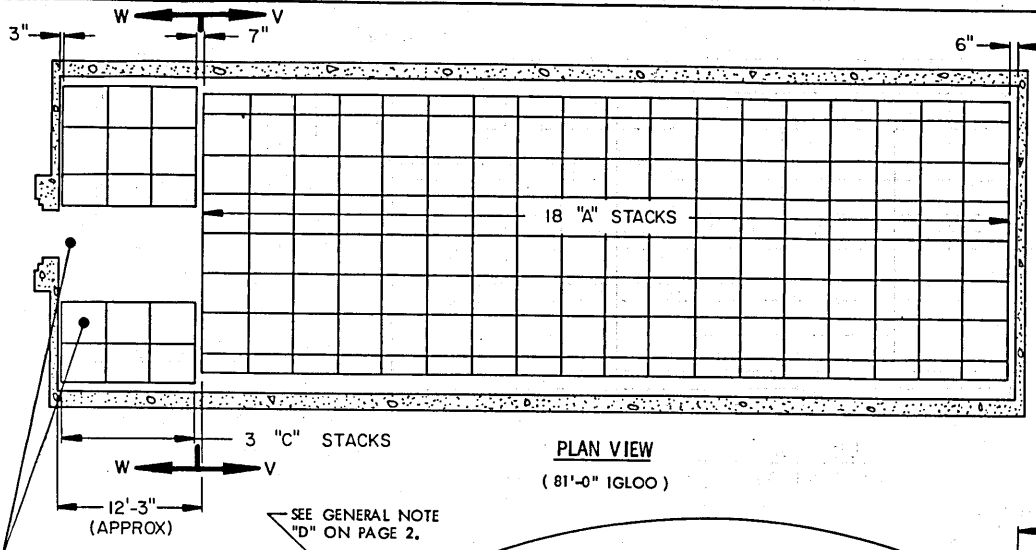

PLAN VIEW
(81'-0" IGLOO)

STORAGE IN 81'-0" IGLOO	
ITEM	QUANTITY
PALLET UNITS	330

* STORAGE IN 60'-8" IGLOO	
ITEM	QUANTITY
PALLET UNITS	237
* 13 A-STACKS	
2 C-STACKS	

** STORAGE IN 40'-4" IGLOO	
ITEM	QUANTITY
PALLET UNITS	143
** 7 A-STACKS	
3 C-STACKS	

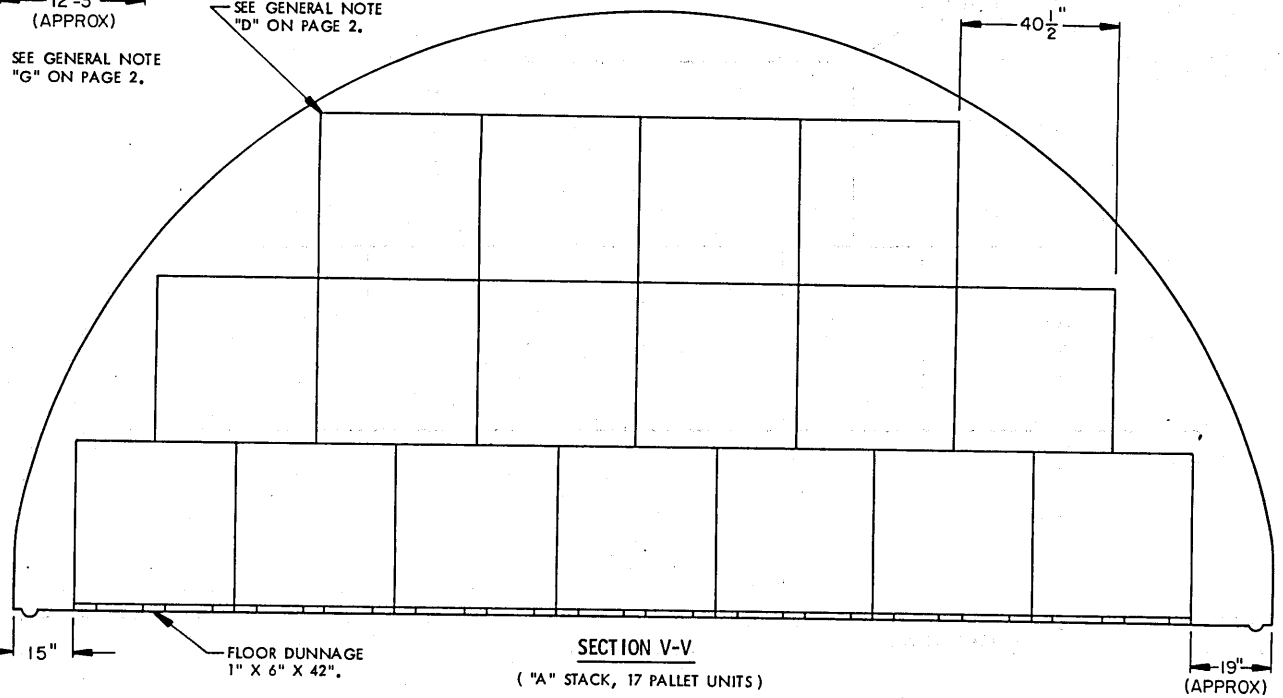

SECTION V-V
("A" STACK, 17 PALLET UNITS)

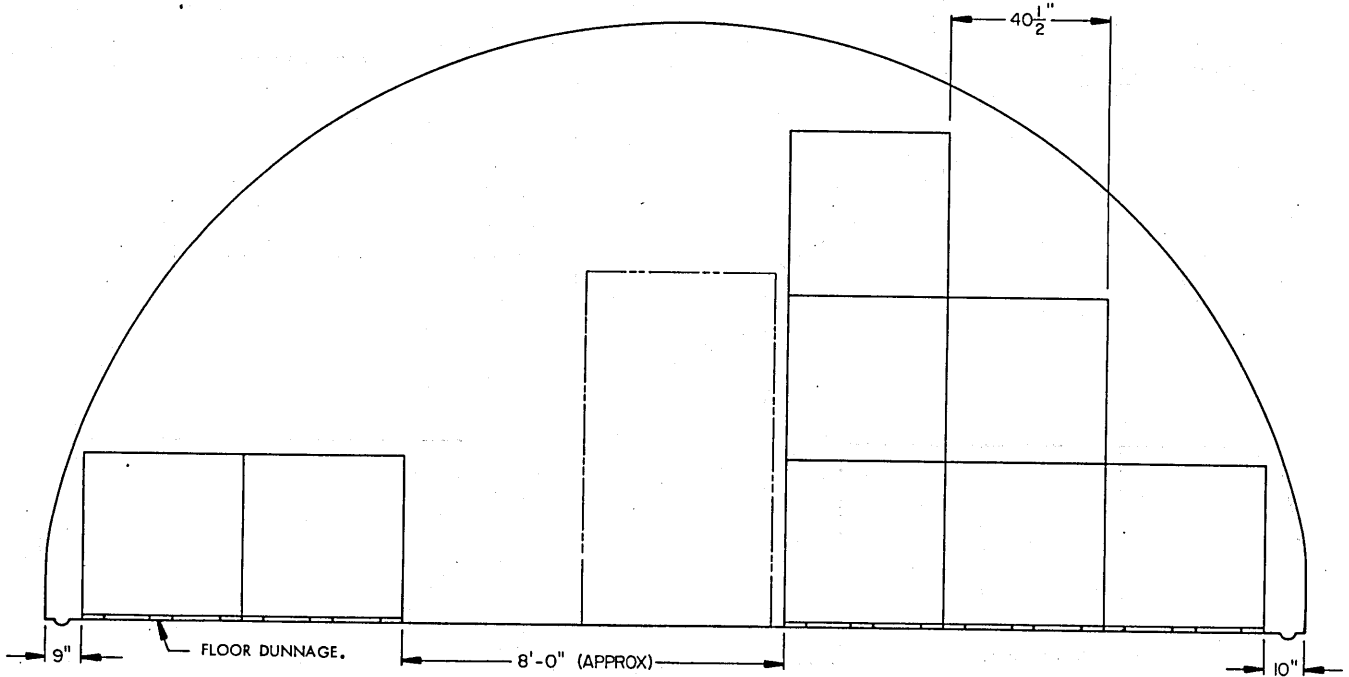

SECTION W-W ("C" STACK, 8 PALLET UNITS)
STORAGE PROCEDURES FOR UNIT NO. 11

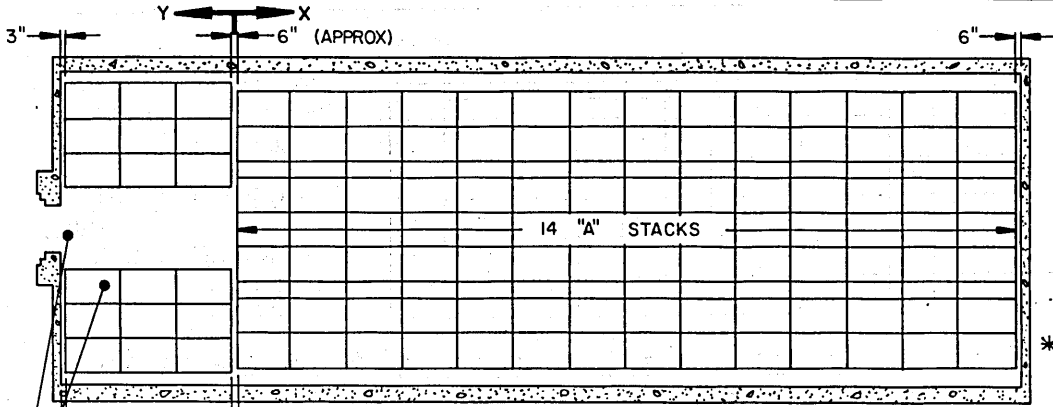

STORAGE IN 81'-0" IGLOO	
ITEM	QUANTITY
PALLET UNITS	262
* STORAGE IN 60'-8" IGLOO	
ITEM	QUANTITY
PALLET UNITS	186
* 10 A-STACKS	
2 C-STACKS	
* STORAGE IN 40'-4" IGLOO	
ITEM	QUANTITY
PALLET UNITS	118
* 6 A-STACKS	
2 C-STACKS	

PLAN VIEW
(81'-0" IGLOO)

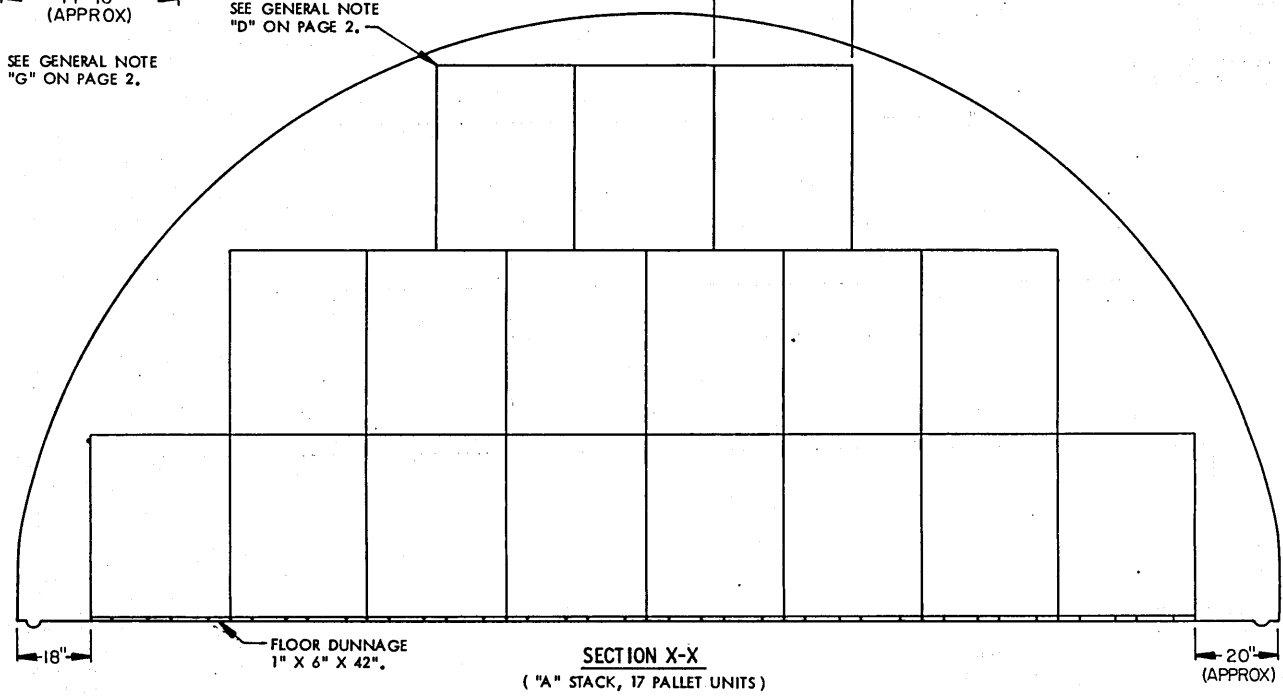

SECTION X-X
("A" STACK, 17 PALLET UNITS)

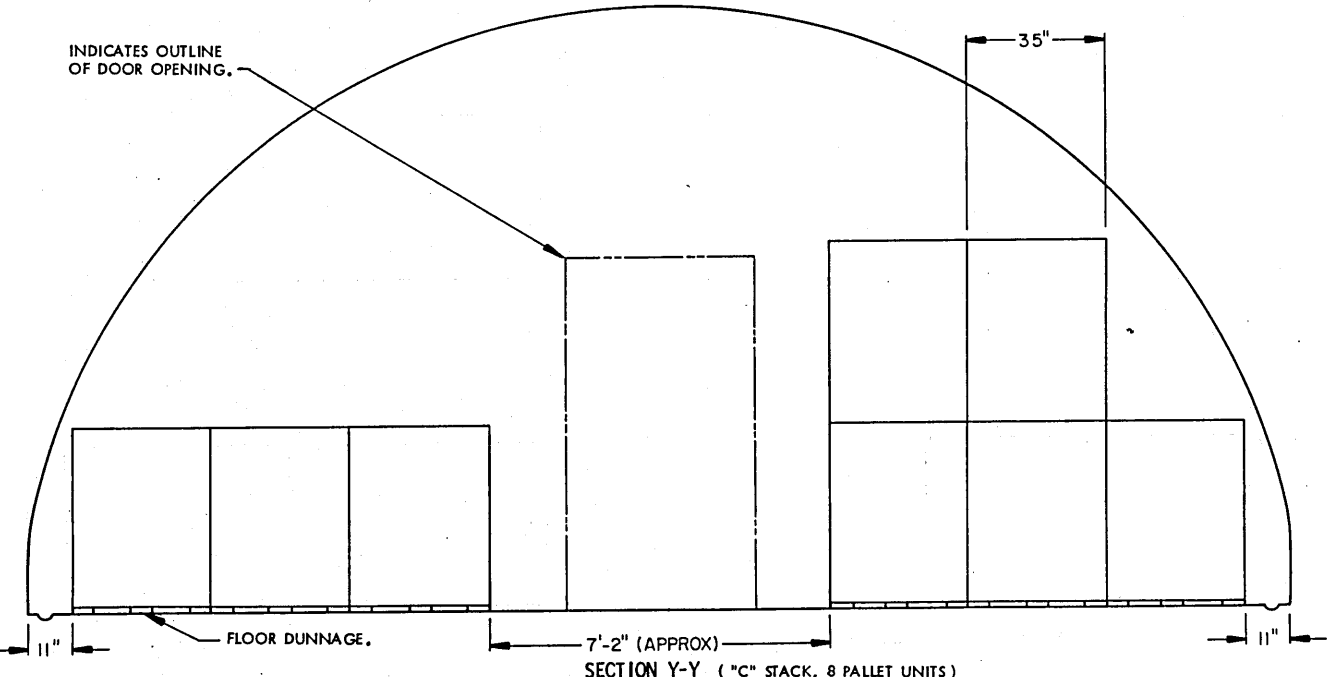

SECTION Y-Y ("C" STACK, 8 PALLET UNITS)

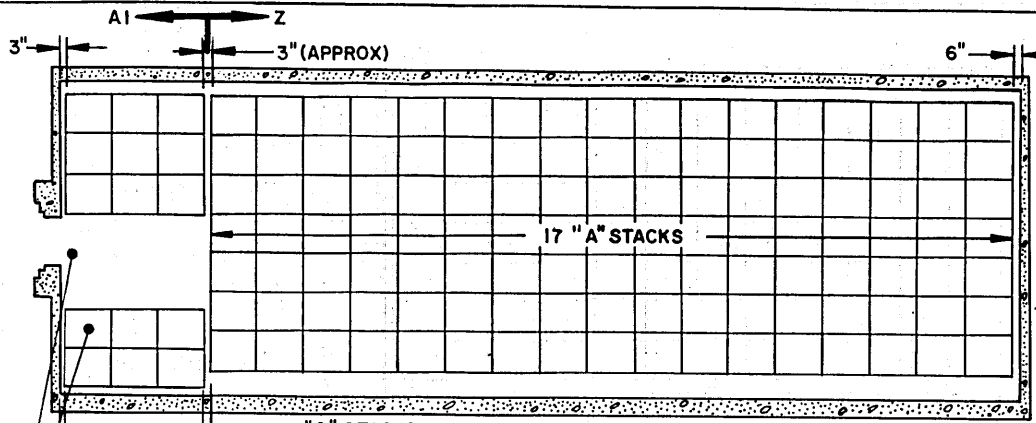

STORAGE IN 81'-0" IGLOO

ITEM	QUANTITY
PALLET UNITS	350

*** STORAGE IN 60'-8" IGLOO**

ITEM	QUANTITY
PALLET UNITS	246

**** STORAGE IN 40'-4" IGLOO**

ITEM	QUANTITY
PALLET UNITS	160
7-A-STACKS	
3-C-STACKS	

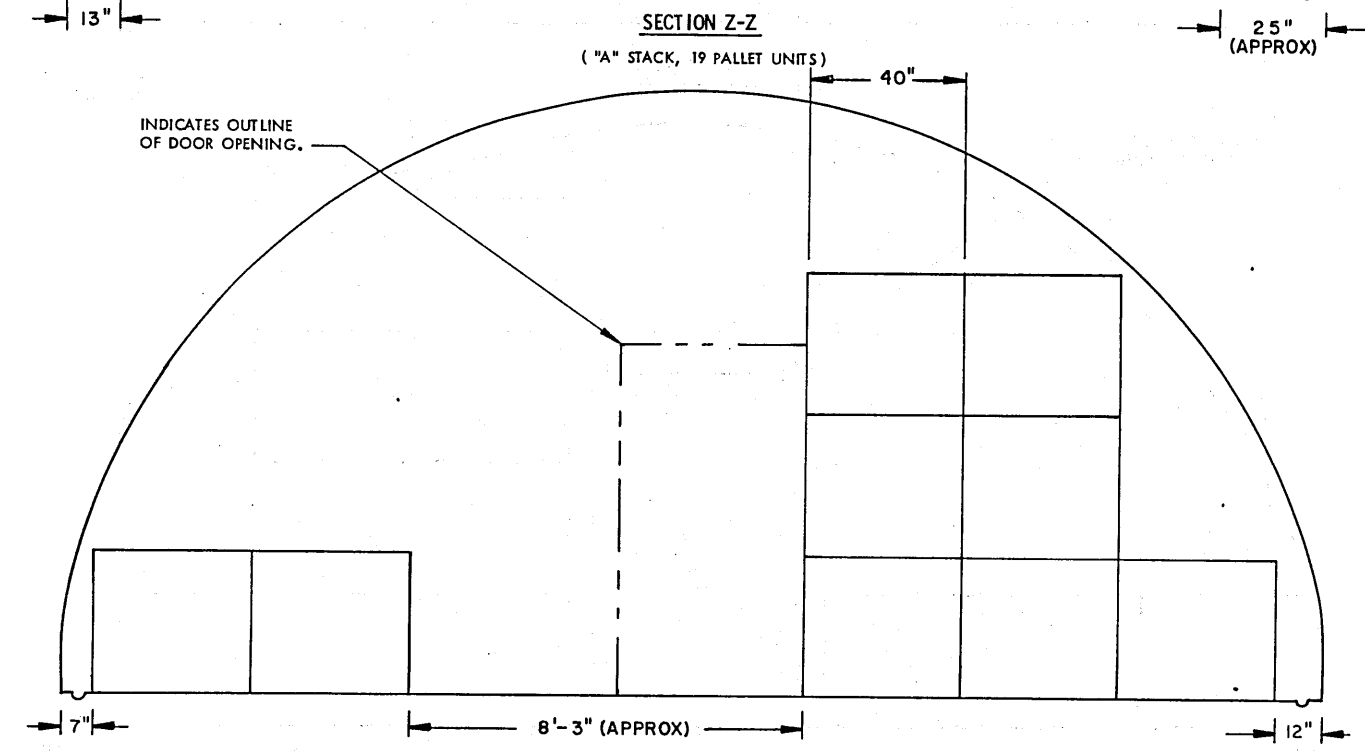
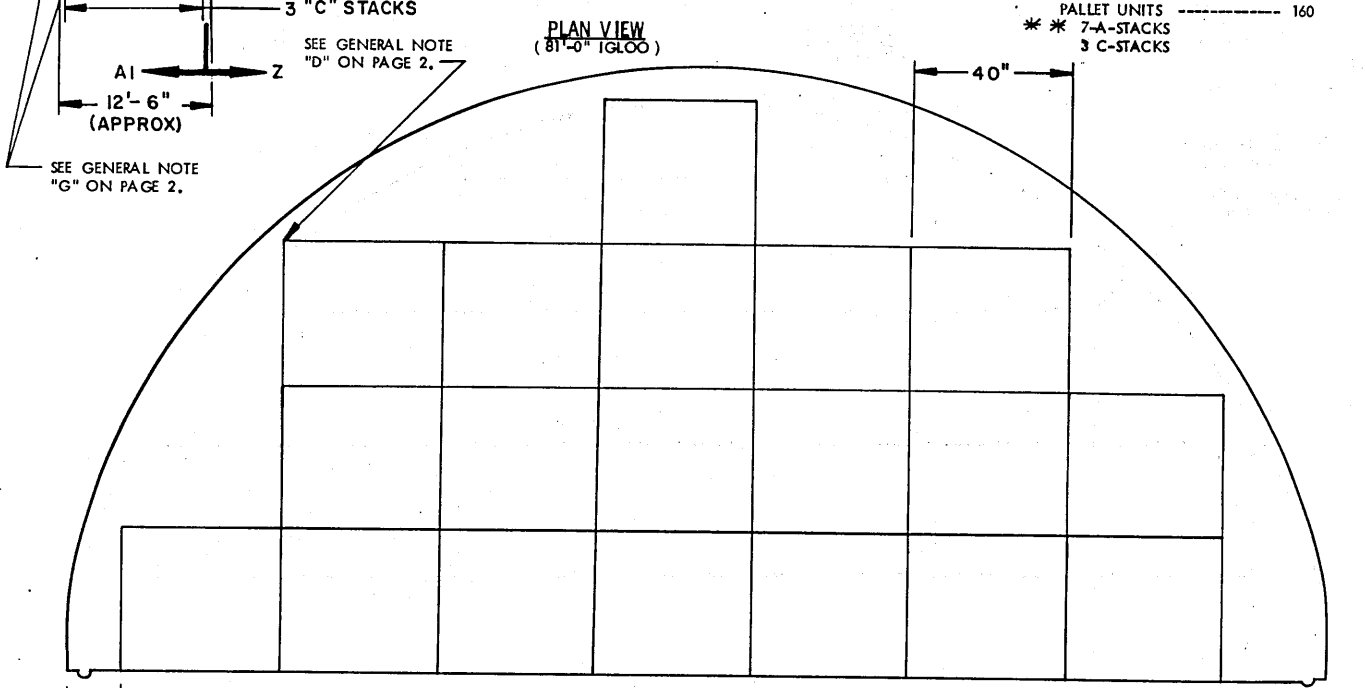

PLAN VIEW
(81'-0" IGLOO)

SECTION Z-Z
("A" STACK, 19 PALLET UNITS)

SECTION A1-A1 ("C" STACK, 9 PALLET UNITS)

STORAGE PROCEDURES FOR UNIT NO. 13

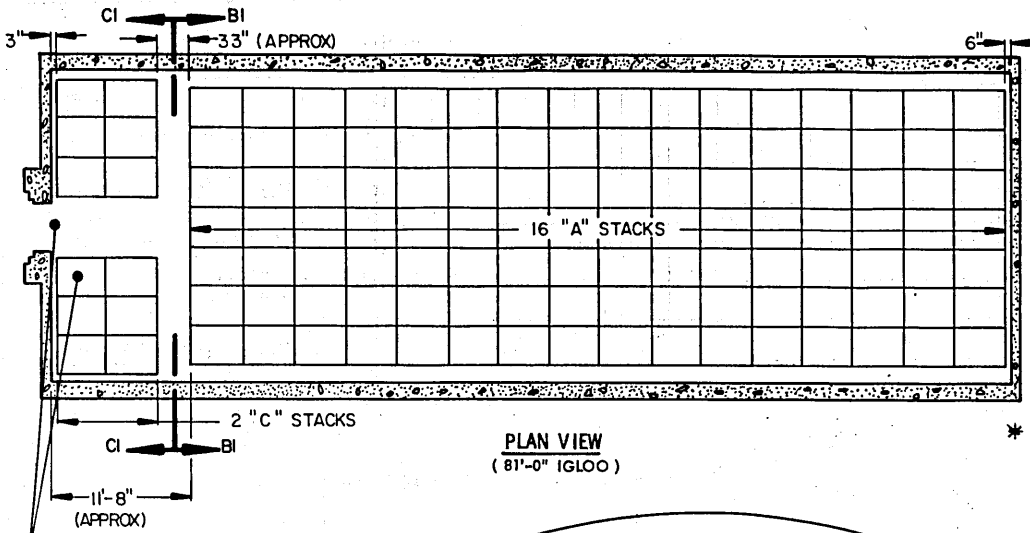

STORAGE IN 81'-0" IGLOO

ITEM	QUANTITY
PALLET UNITS	374

*** STORAGE IN 60'-8" IGLOO**

ITEM	QUANTITY
PALLET UNITS	275
* 11 A-STACKS	
3 C-STACKS	

**** STORAGE IN 40'-4" IGLOO**

ITEM	QUANTITY
PALLET UNITS	165
** 6 A-STACKS	
3 C-STACKS	

PLAN VIEW
(81'-0" IGLOO)

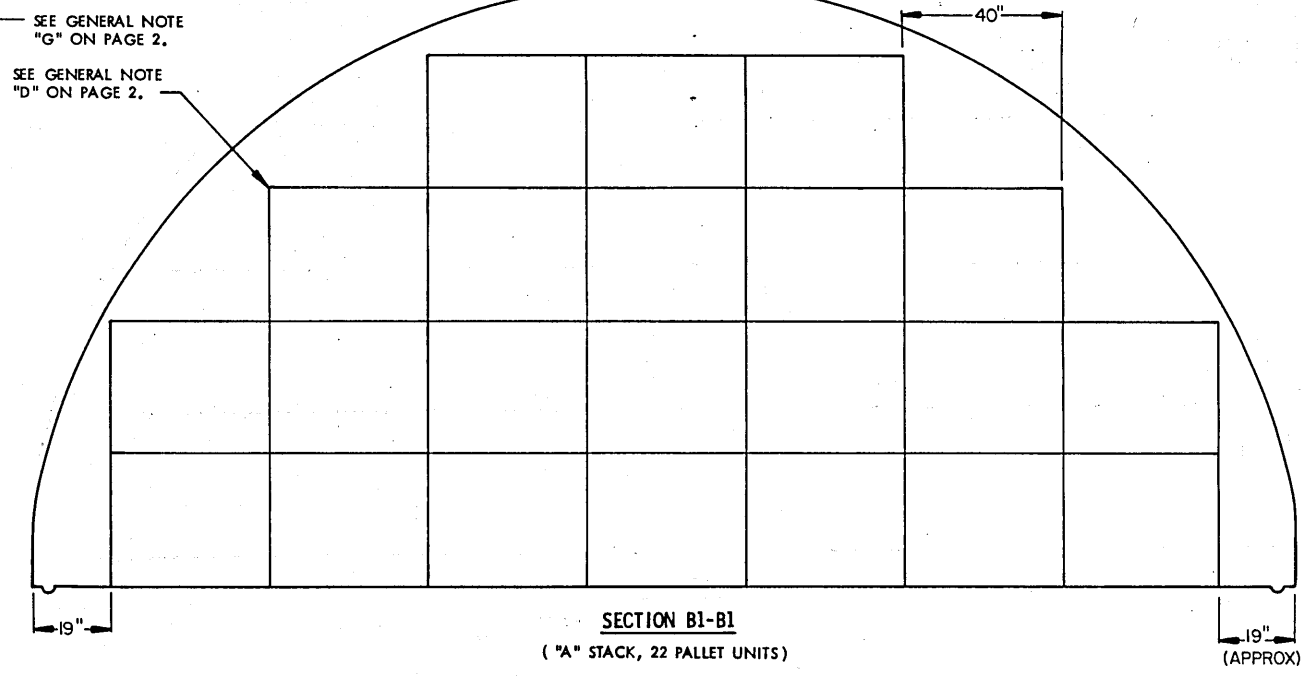

SECTION B1-B1
("A" STACK, 22 PALLET UNITS)

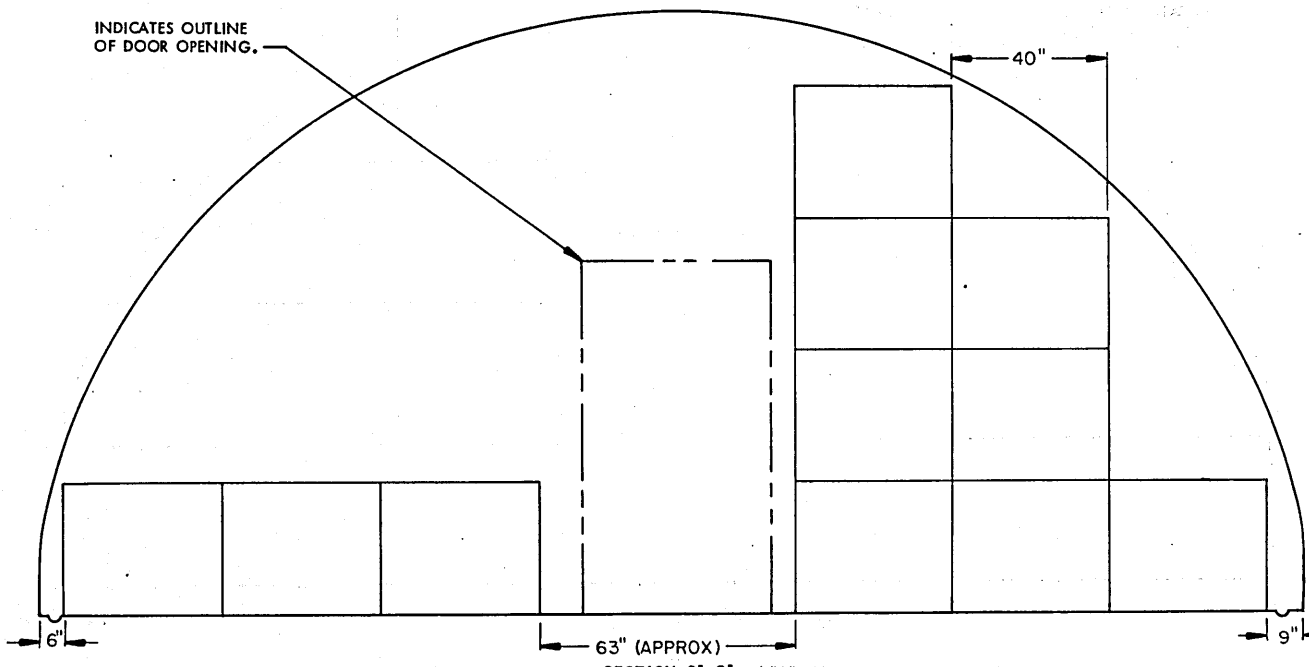

INDICATES OUTLINE OF DOOR OPENING.

SECTION C1-C1 ("C" STACK, 11 PALLET UNITS)
STORAGE PROCEDURES FOR UNIT NO. 14

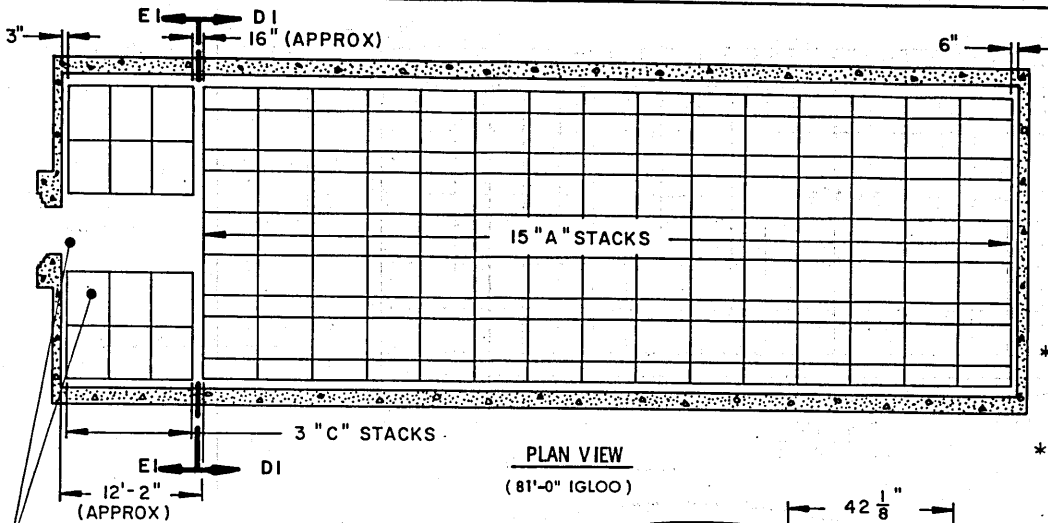

STORAGE IN 81'-0" IGLOO	
ITEM	QUANTITY
PALLET UNITS	255
* STORAGE IN 60'-8" IGLOO	
ITEM	QUANTITY
PALLET UNITS	180
10 A-STACKS	
4 C-STACKS	
** STORAGE IN 40'-4" IGLOO	
ITEM	QUANTITY
PALLET UNITS	111
6 A-STACKS	
3 C-STACKS	

PLAN VIEW
(81'-0" IGLOO)

SEE GENERAL NOTE "G" ON PAGE 2.

SEE GENERAL NOTE "D" ON PAGE 2.

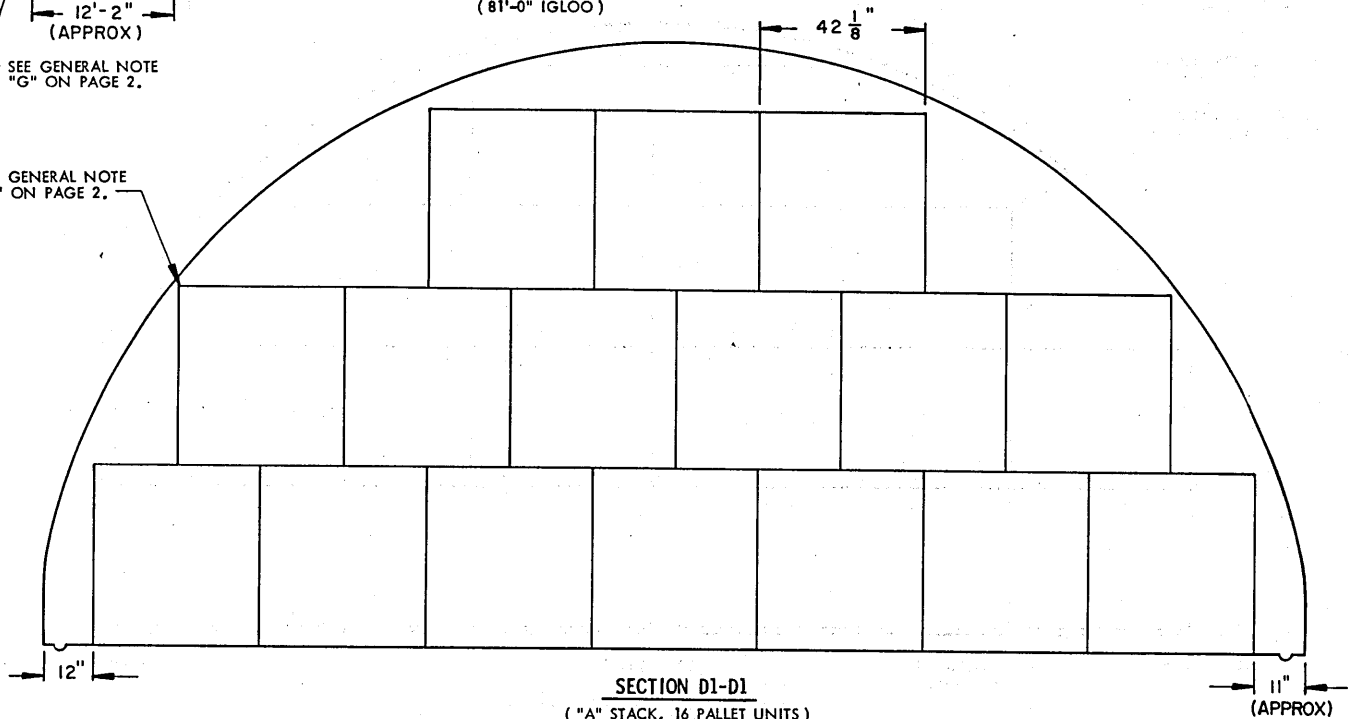

INDICATES OUTLINE OF DOOR OPENING.

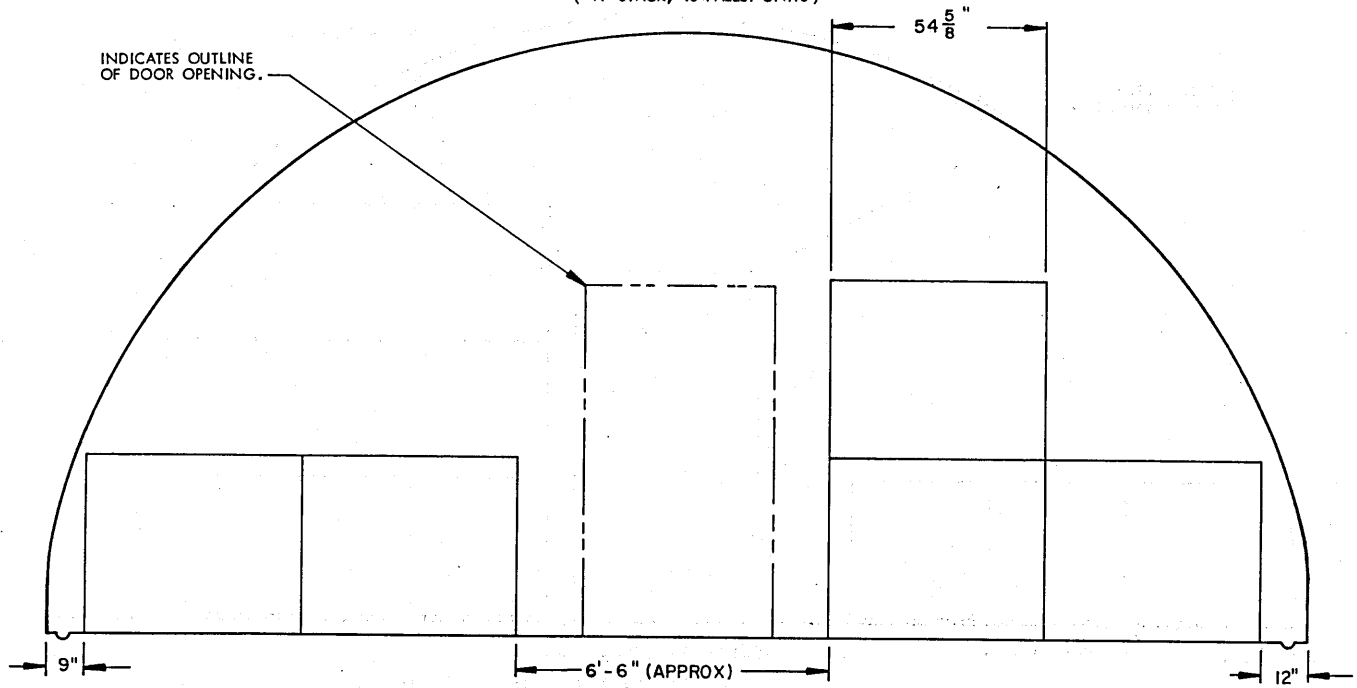

SECTION E1-E1 ("C" STACK, 5 PALLET UNITS)
STORAGE PROCEDURES FOR UNIT NO. 15

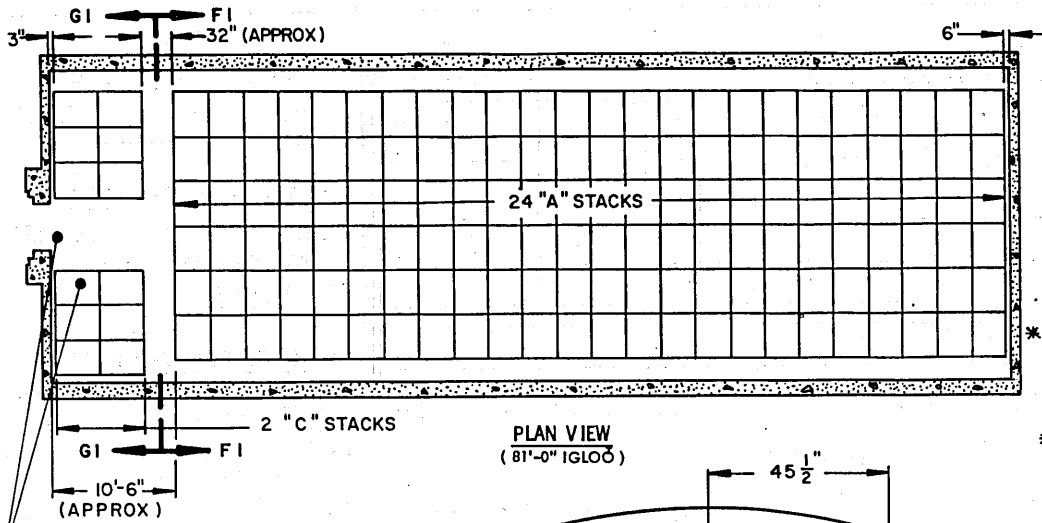

STORAGE IN 81'-0" IGLOO	
ITEM	QUANTITY
PALLET UNITS	454
* STORAGE IN 60'-8" IGLOO	
ITEM	QUANTITY
PALLET UNITS	328
* 17 A-STACKS 2 C-STACKS	
* STORAGE IN 40'-4" IGLOO	
ITEM	QUANTITY
PALLET UNITS	202
* 10 A-STACKS 2 C-STACKS	

PLAN VIEW
(81'-0" IGLOO)

SEE GENERAL NOTE
"G" ON PAGE 2.

SEE GENERAL NOTE
"D" ON PAGE 2.

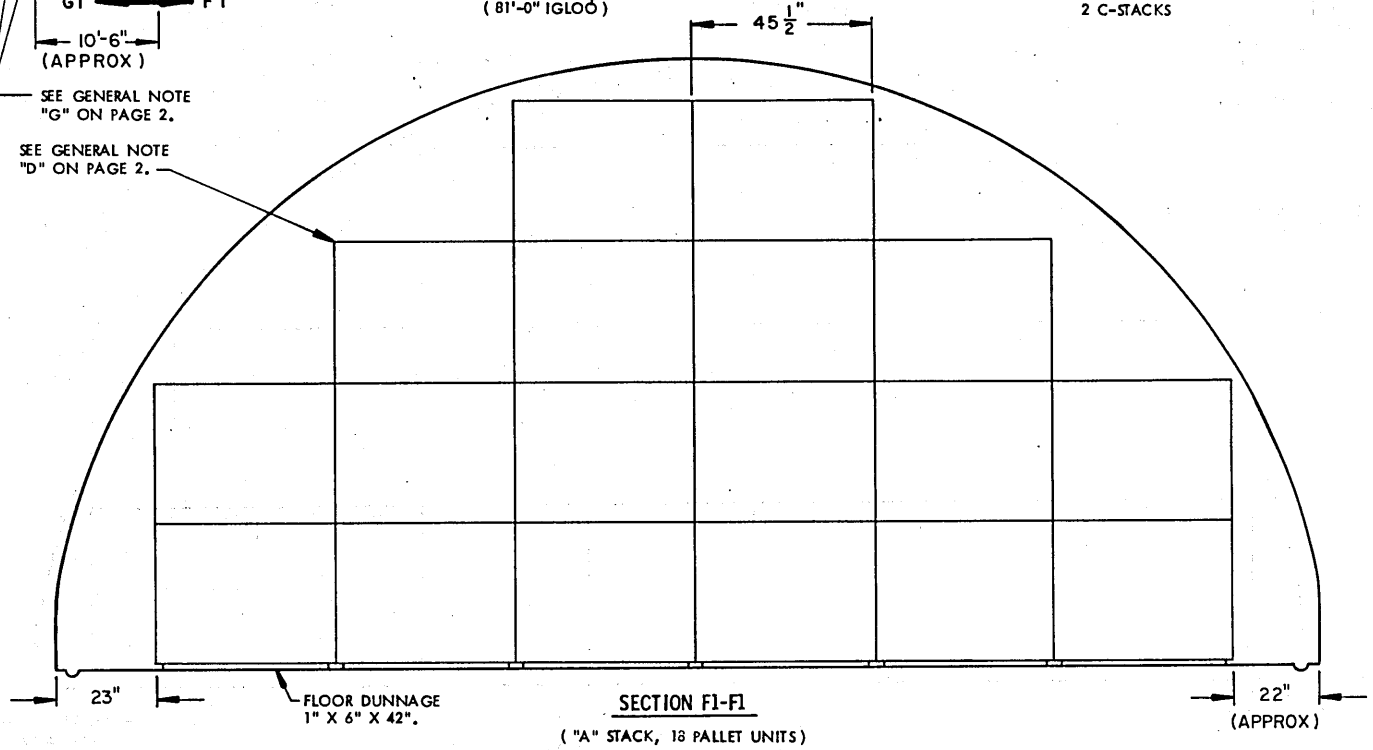

SECTION F1-F1
("A" STACK, 18 PALLET UNITS)

INDICATES OUTLINE
OF DOOR OPENING.

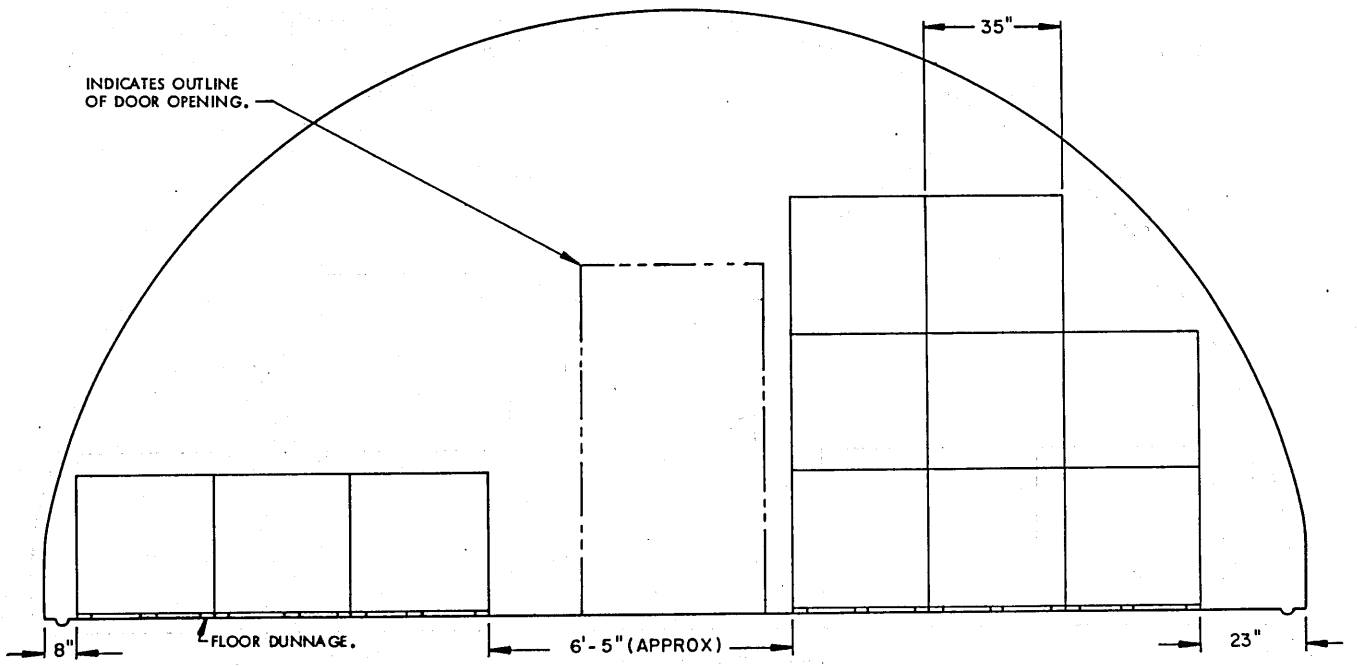

SECTION G1-G1 ("C" STACK, 11 PALLET UNITS)
STORAGE PROCEDURES FOR UNIT NO. 16

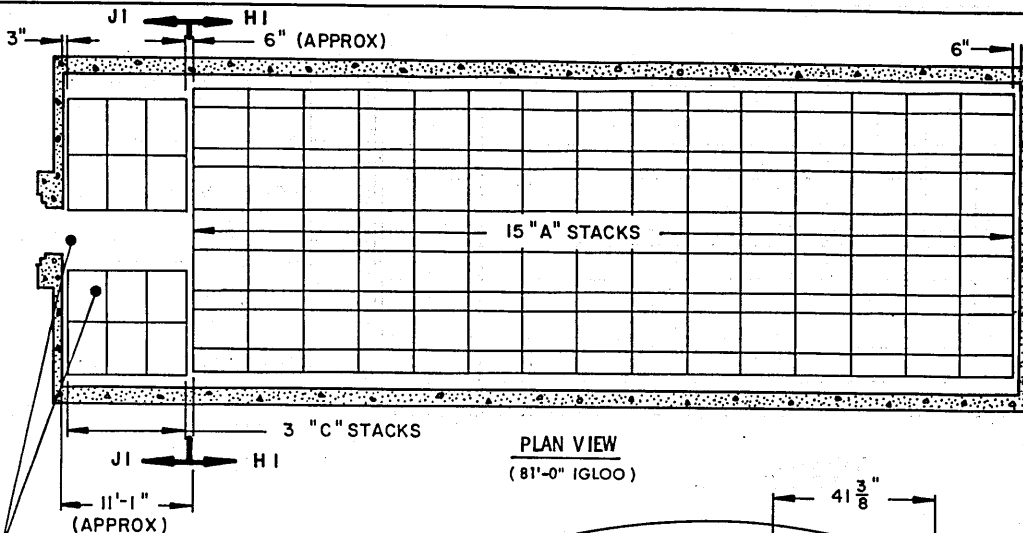

STORAGE IN 81'-0" IGLOO

ITEM	QUANTITY
PALLET UNITS	258

*** STORAGE IN 60'-8" IGLOO**

ITEM	QUANTITY
PALLET UNITS	178
* 10 A-STACKS	
3 C-STACKS	

**** STORAGE IN 40'-4" IGLOO**

ITEM	QUANTITY
PALLET UNITS	114
* 6 A-STACKS	
3 C-STACKS	

SEE GENERAL NOTE "G" ON PAGE 2.

SEE GENERAL NOTE "D" ON PAGE 2.

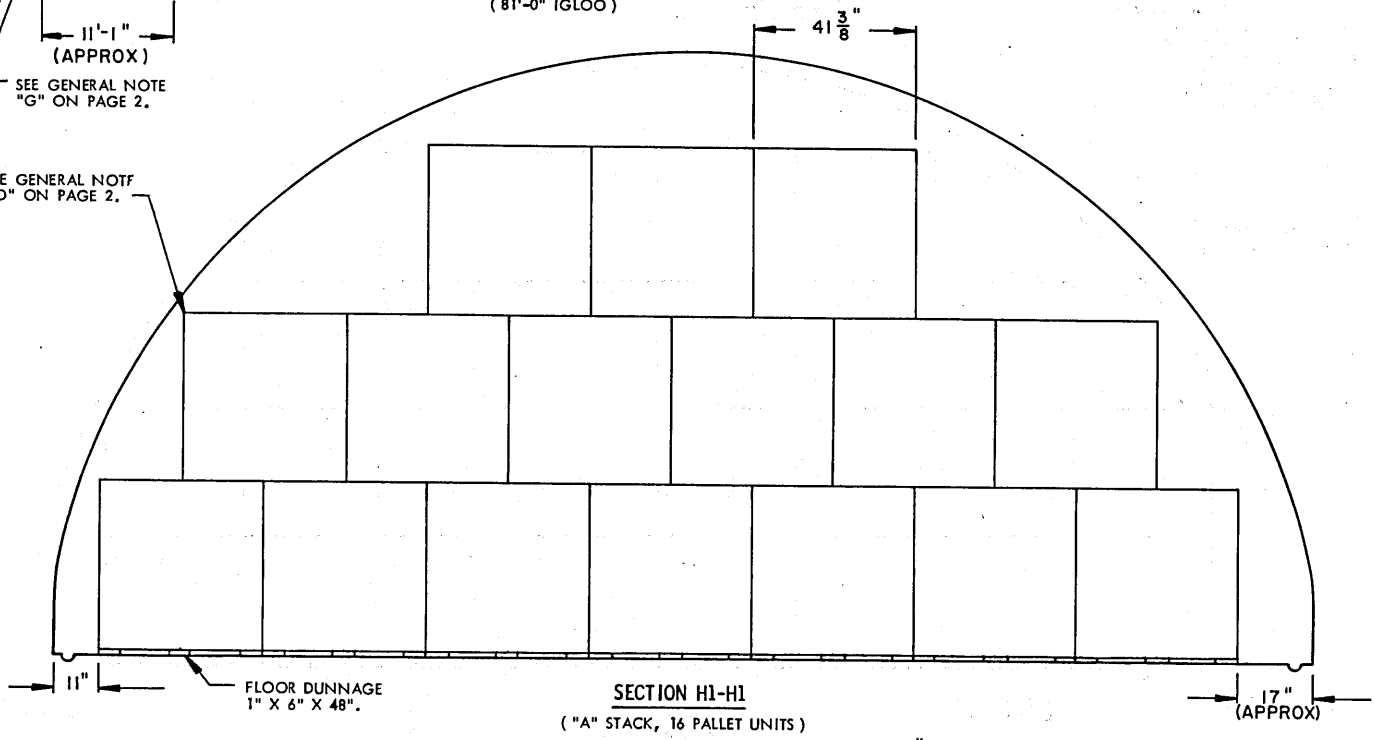

INDICATES OUTLINE OF DOOR OPENING.

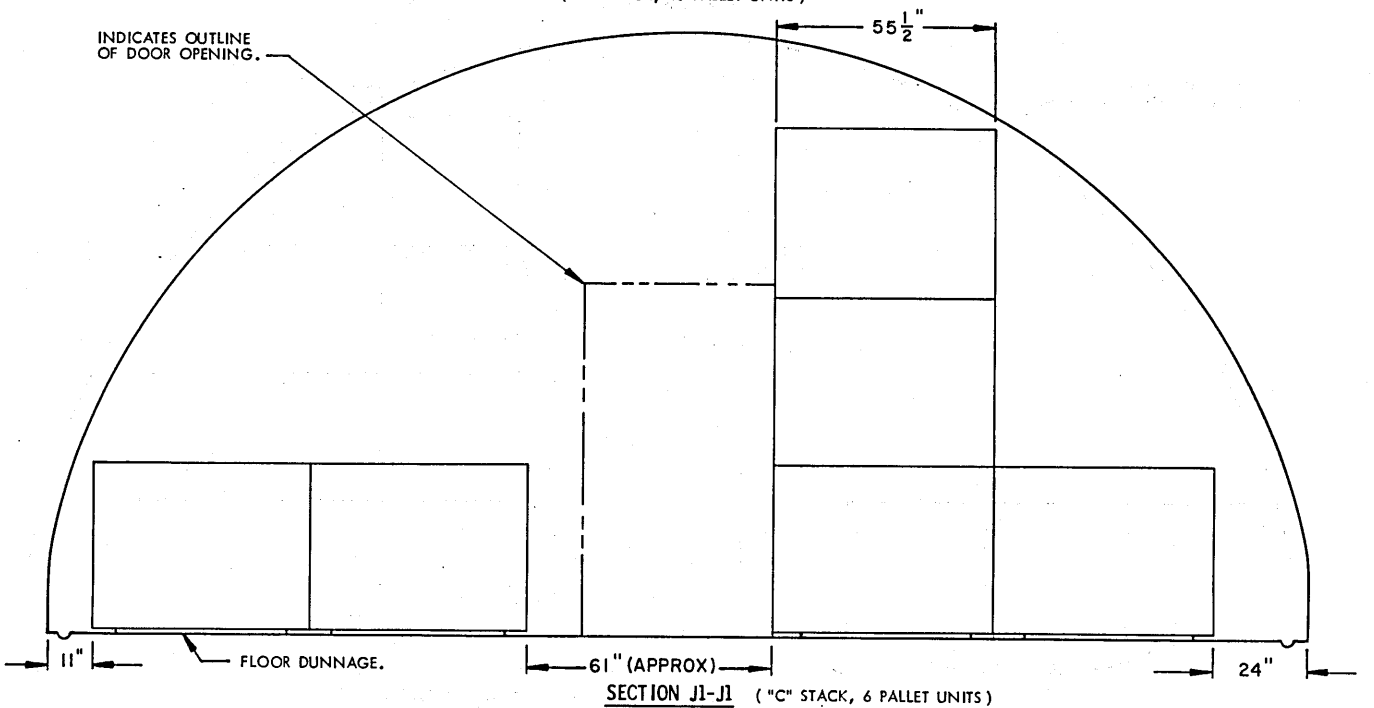

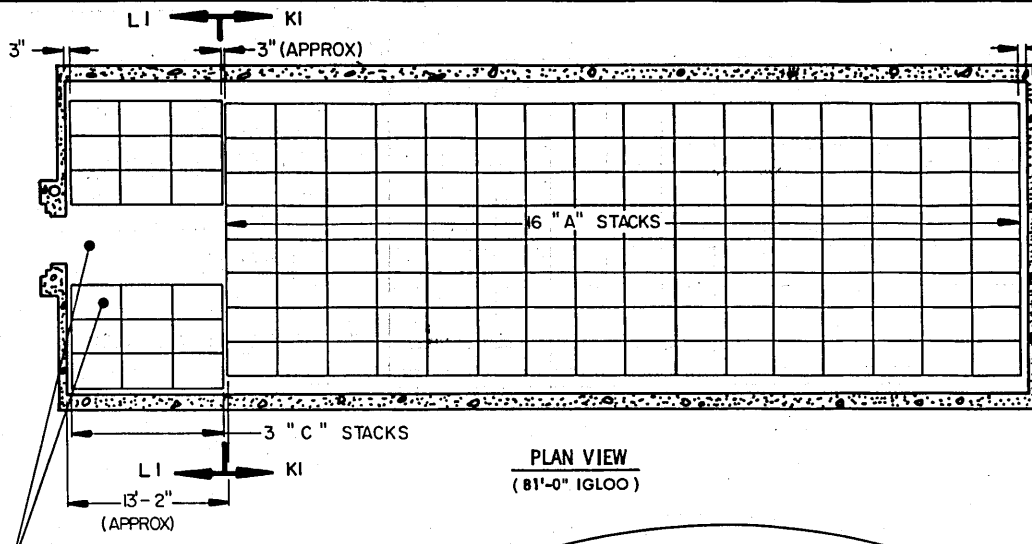

PLAN VIEW
(81'-0" IGLOO)

STORAGE IN 81'-0" IGLOO	
ITEM	QUANTITY
PALLET UNITS	452
* STORAGE IN 60'-8" IGLOO	
ITEM	QUANTITY
PALLET UNITS	322
* 11 A-STACKS	
3 C-STACKS	
** STORAGE IN 40'-4" IGLOO	
ITEM	QUANTITY
PALLET UNITS	192
** 6 A-STACKS	
3 C-STACKS	

SEE GENERAL NOTE "G" ON PAGE 2.

SEE GENERAL NOTE "D" ON PAGE 2.

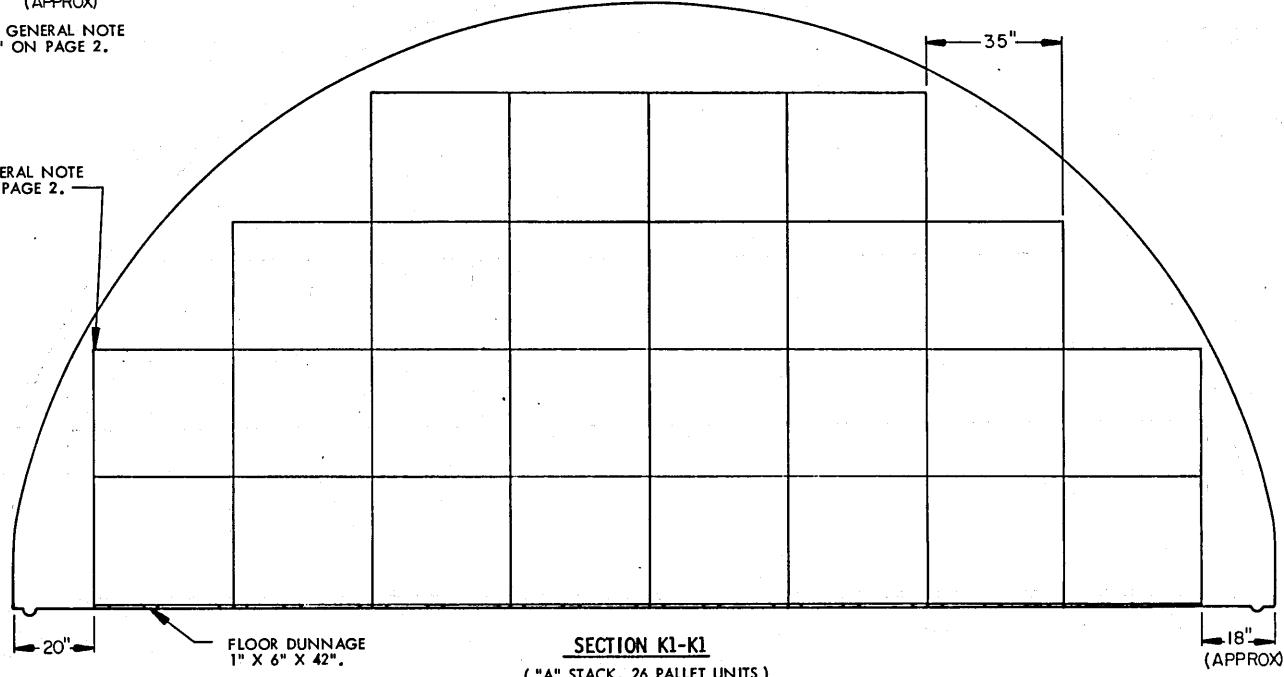

SECTION K1-K1
("A" STACK, 26 PALLET UNITS)

INDICATES OUTLINE OF DOOR OPENING.

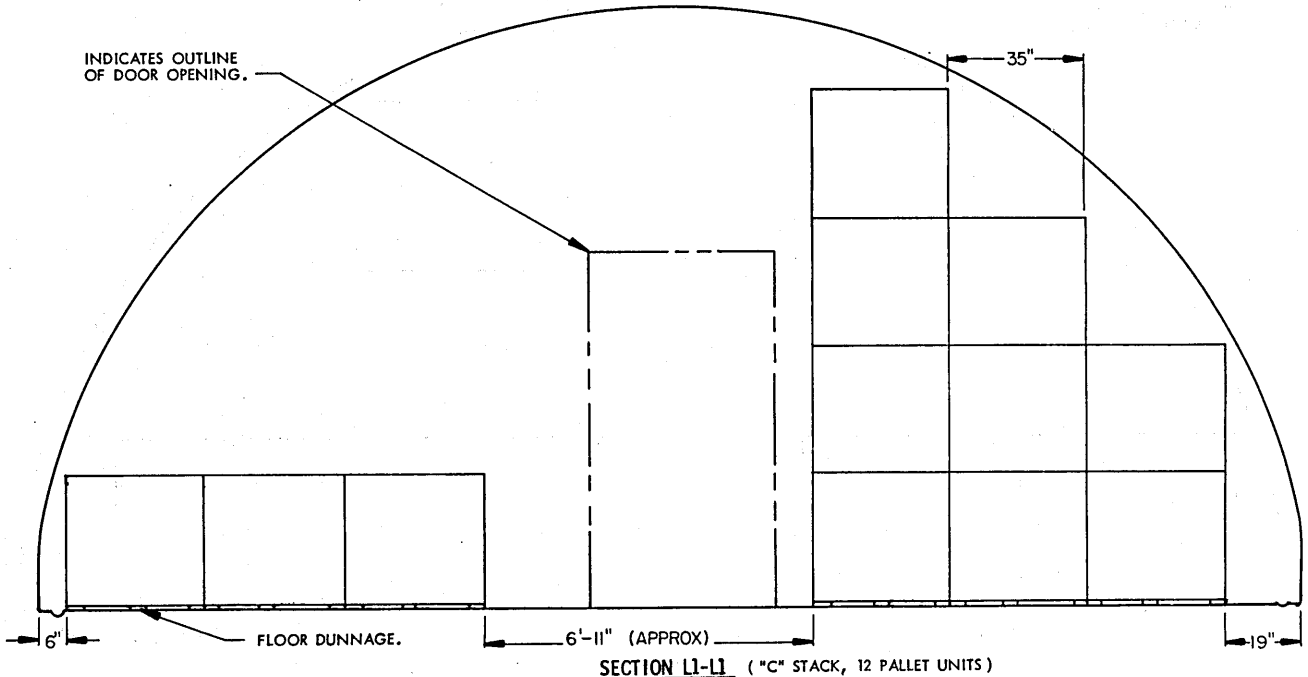

SECTION L1-L1 ("C" STACK, 12 PALLET UNITS)

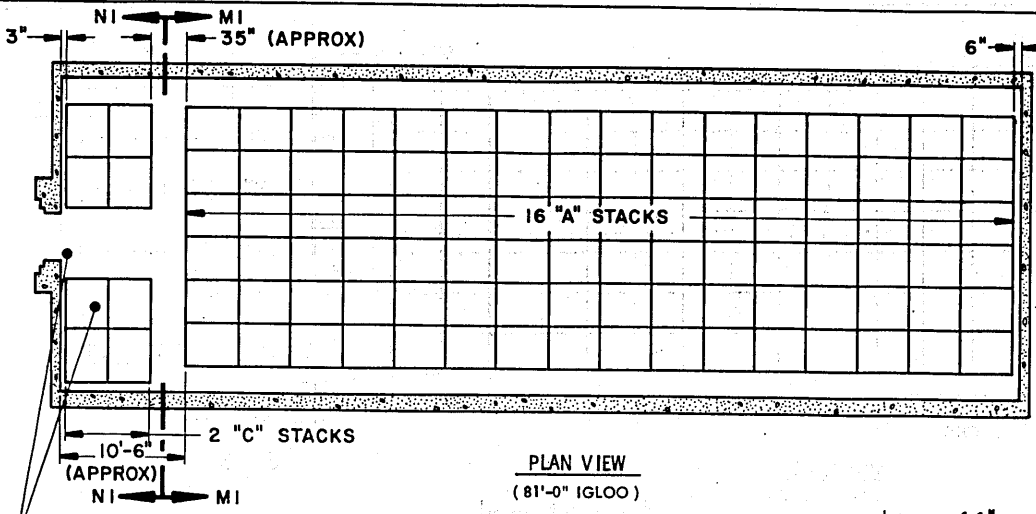

STORAGE IN 81'-0" IGLOO	
ITEM	QUANTITY
PALLET UNITS	270
* STORAGE IN 60'-8" IGLOO	
ITEM	QUANTITY
PALLET UNITS	197
* 11 A-STACKS	
3 C-STACKS	
** STORAGE IN 40'-4" IGLOO	
ITEM	QUANTITY
PALLET UNITS	117
* 6 A-STACKS	
3 C-STACKS	

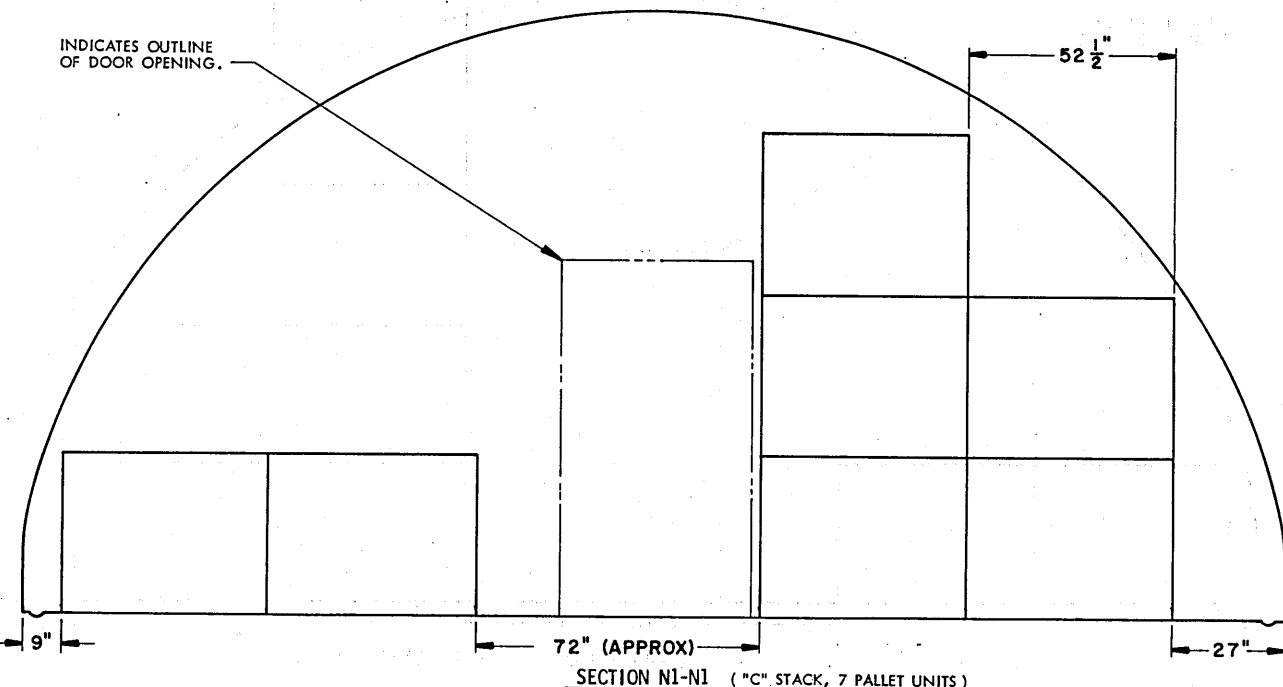
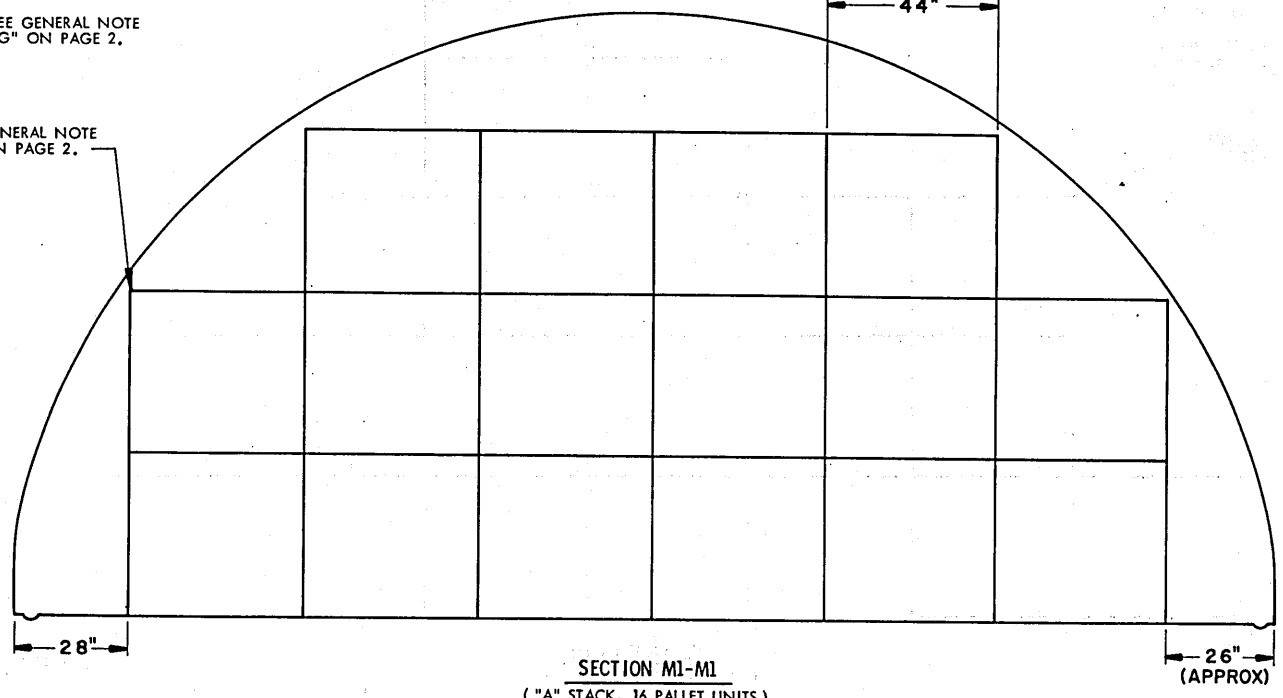

STORAGE PROCEDURES FOR UNIT NO. 19

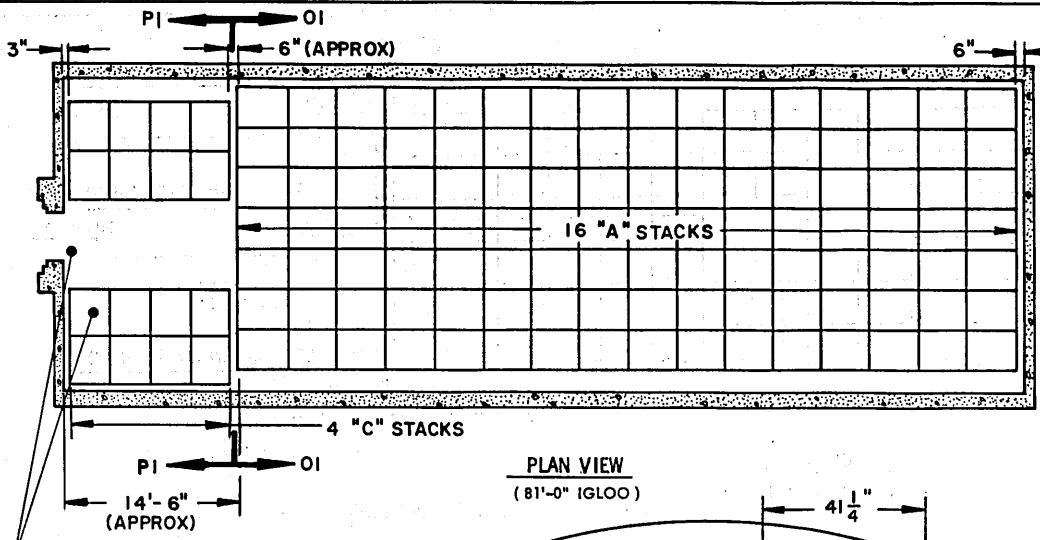

STORAGE IN 81'-0" IGLOO

ITEM	QUANTITY
PALLET UNITS	348

*** STORAGE IN 60'-8" IGLOO**

ITEM	QUANTITY
PALLET UNITS	261
12 A-STACKS	
3 C-STACKS	

**** STORAGE IN 40'-4" IGLOO**

ITEM	QUANTITY
PALLET UNITS	161
7 A-STACKS	
3 C-STACKS	

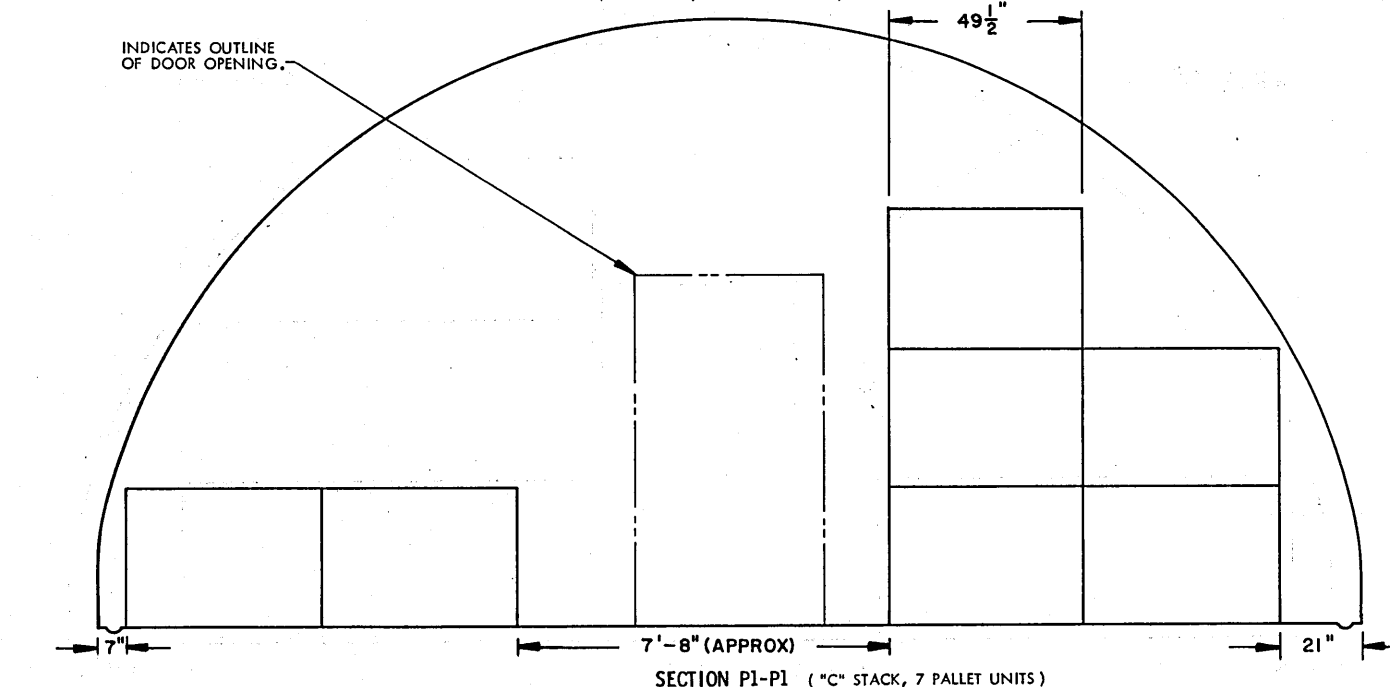
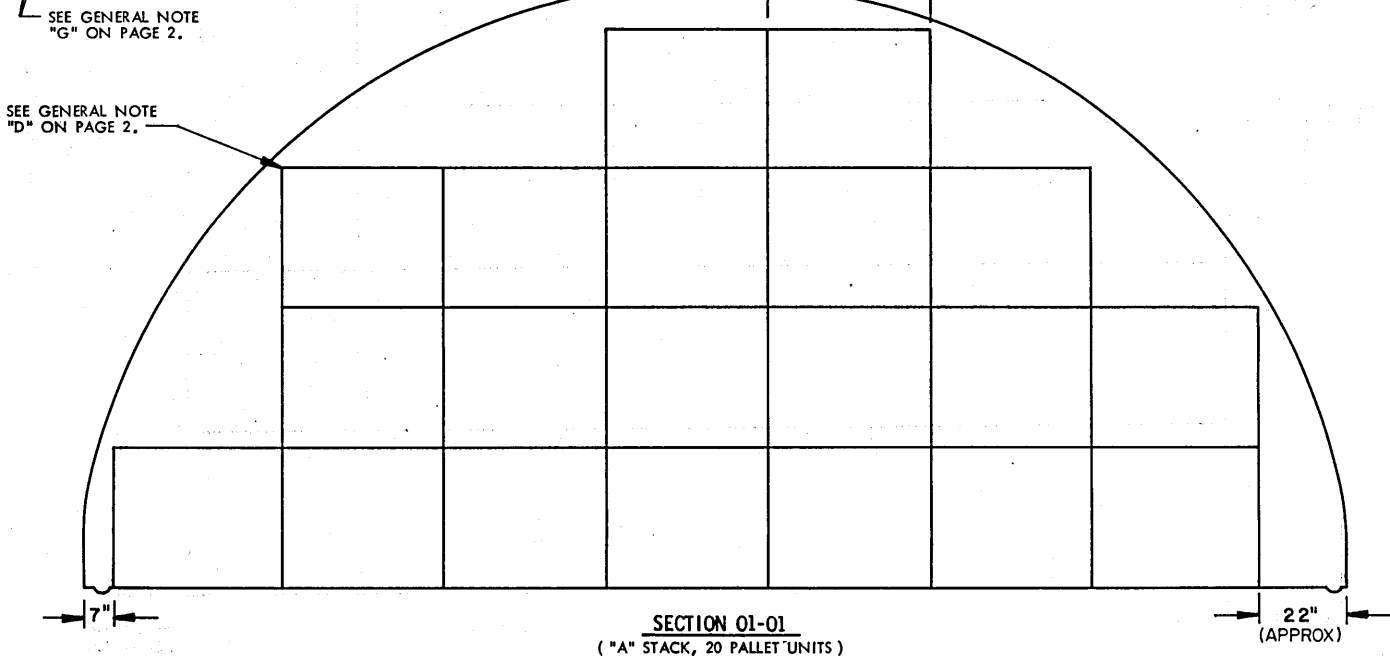

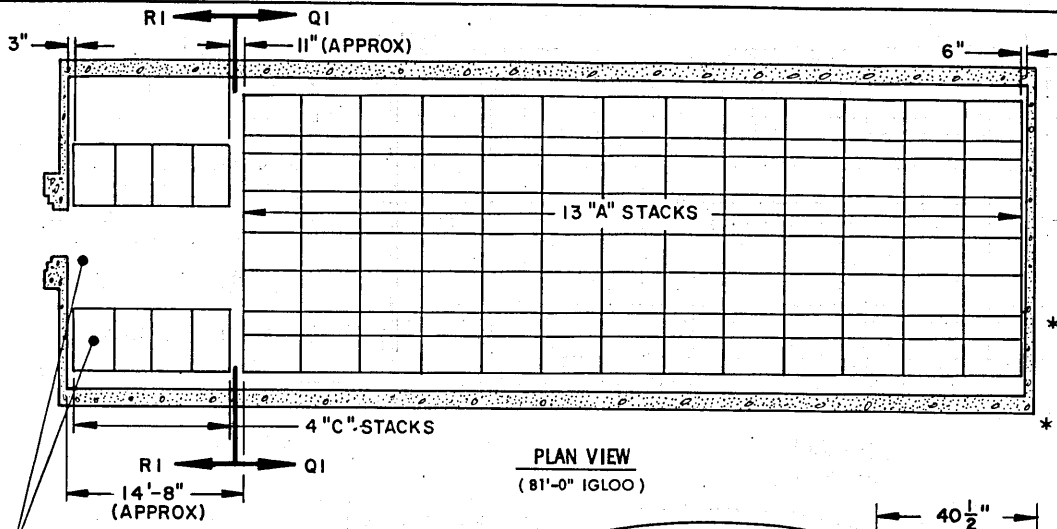

STORAGE IN 81'-0" IGLOO	
ITEM	QUANTITY
PALLET UNITS	155
* STORAGE IN 60'-8" IGLOO	
ITEM	QUANTITY
PALLET UNITS	111
* 9 A-STACKS 4 C-STACKS	
** STORAGE IN 40'-4" IGLOO	
ITEM	QUANTITY
PALLET UNITS	67
** 5 A-STACKS 4 C-STACKS	

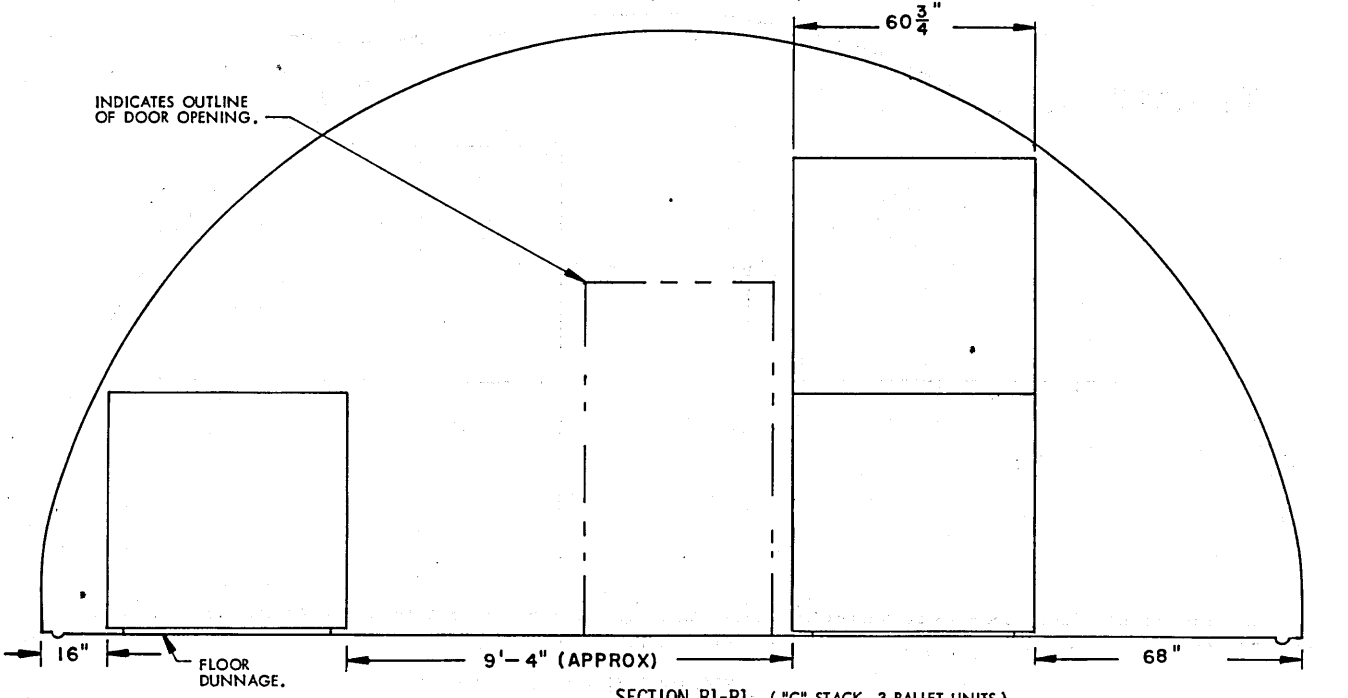
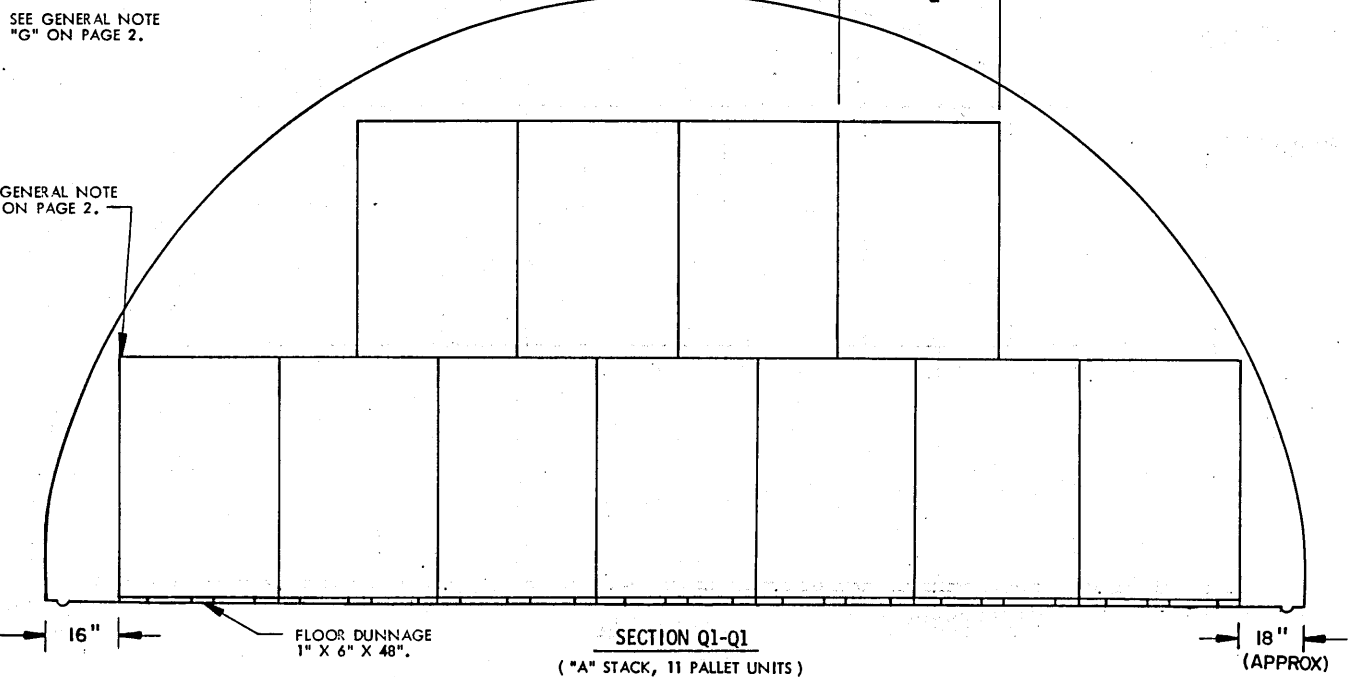

STORAGE PROCEDURES FOR UNIT NO. 21

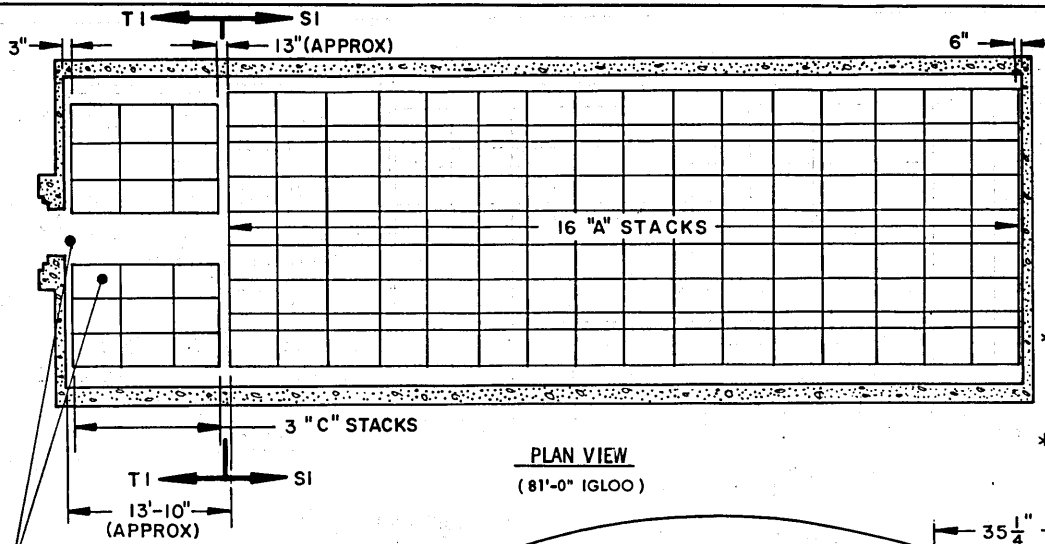

STORAGE IN 81'-0" IGLOO	
ITEM	QUANTITY
PALLET UNITS	232
* STORAGE IN 60'-8" IGLOO	
ITEM	QUANTITY
PALLET UNITS	167
11 A-STACKS	
3 C-STACKS	
* * STORAGE IN 40'-4" IGLOO	
ITEM	QUANTITY
PALLET UNITS	107
7 A-STACKS	
2 C-STACKS	

PLAN VIEW
(81'-0" IGLOO)

SEE GENERAL NOTE "D" ON PAGE 2.

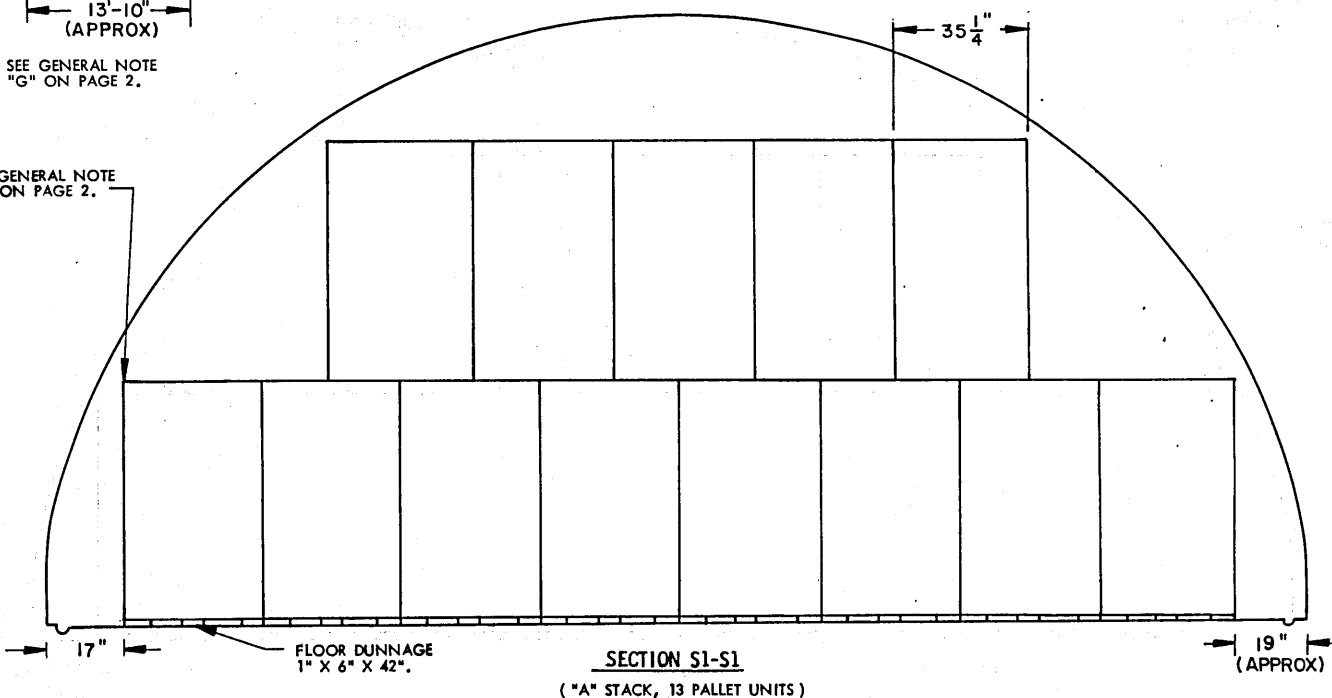

INDICATES OUTLINE OF DOOR OPENING.

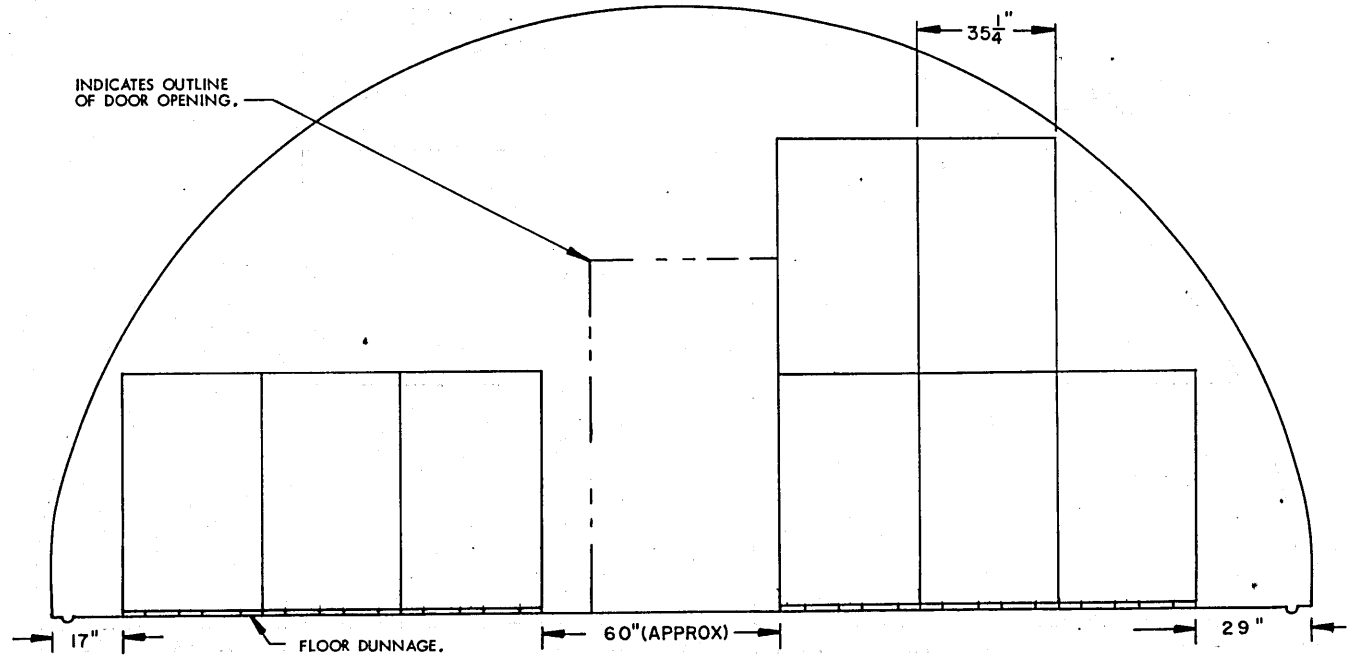

SECTION T1-T1 (* "C" STACK, 8 PALLET UNITS)
STORAGE PROCEDURES FOR UNIT NO. 22

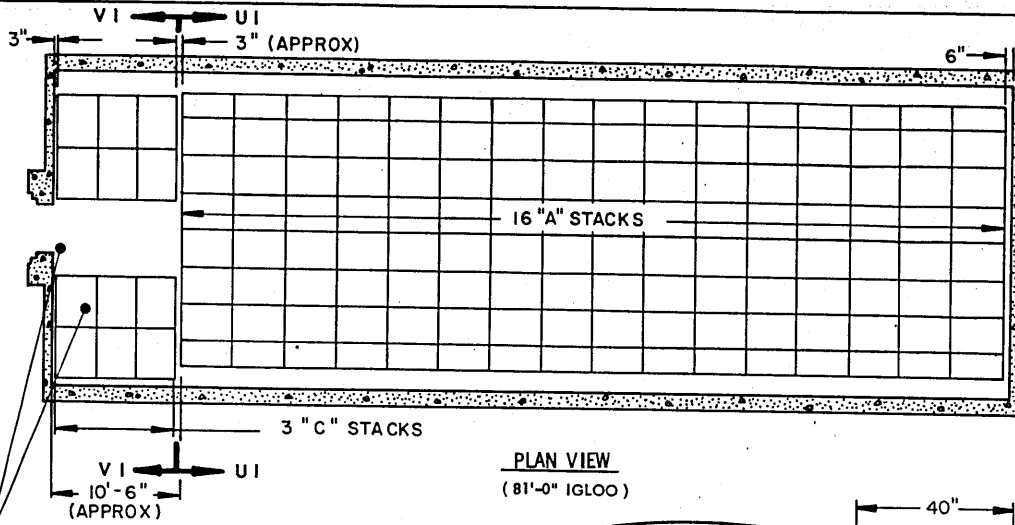

STORAGE IN 81'-0" IGLOO

ITEM	QUANTITY
PALLET UNITS	408

*** STORAGE IN 60'-8" IGLOO**

ITEM	QUANTITY
PALLET UNITS	288
11 A-STACKS	
3 C-STACKS	

**** STORAGE IN 40'-4" IGLOO**

ITEM	QUANTITY
PALLET UNITS	168
6 A-STACKS	
3 C-STACKS	

PLAN VIEW
(81'-0" IGLOO)

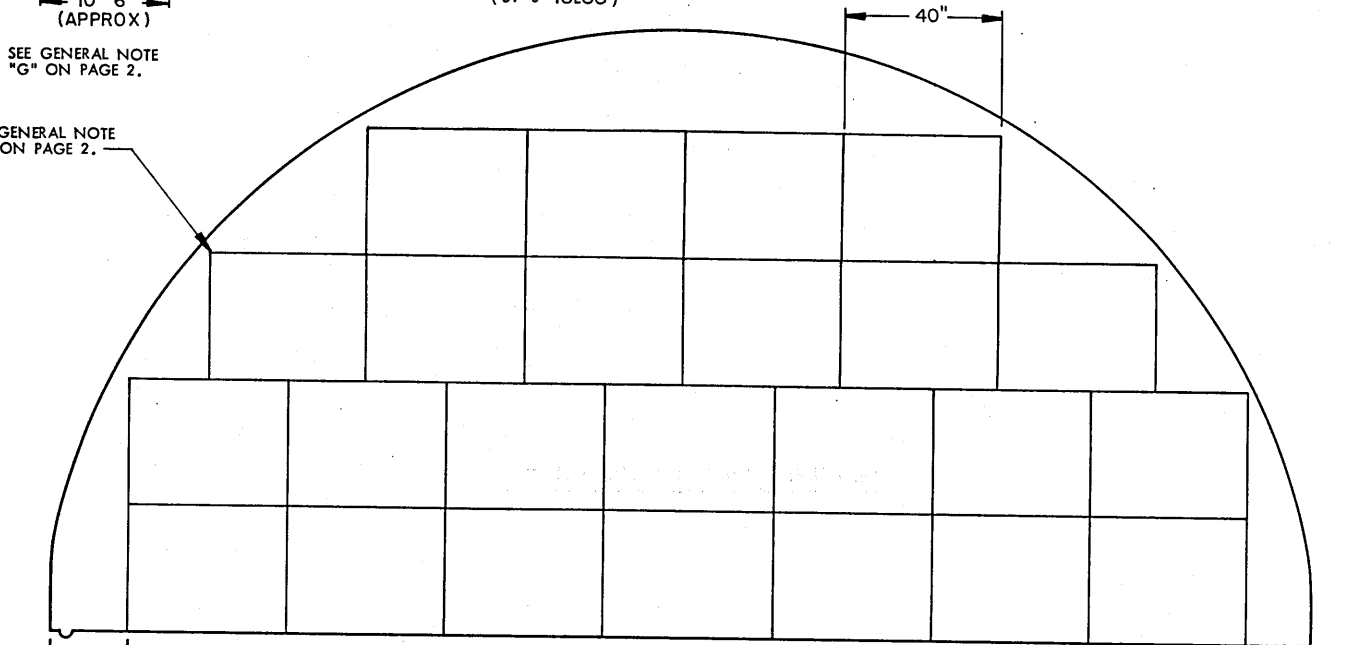

SECTION U1-U1
("A" STACK, 24 PALLET UNITS)

INDICATES OUTLINE OF DOOR OPENING.

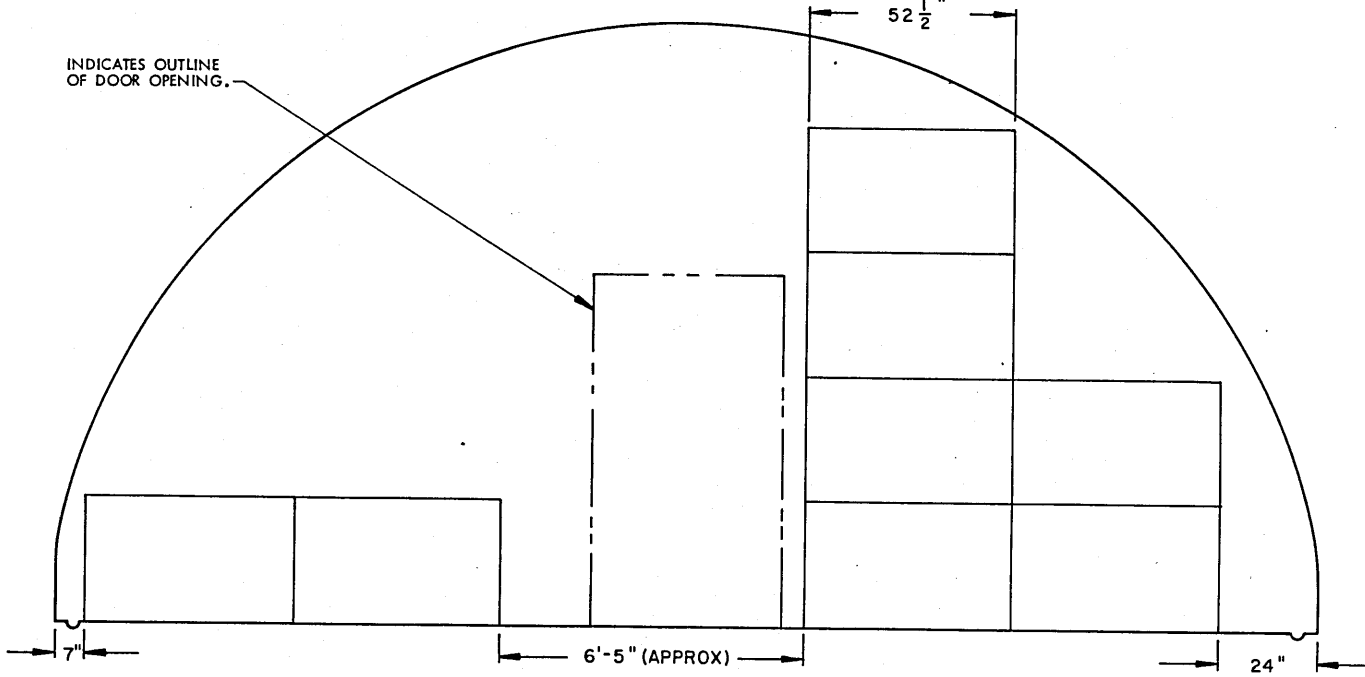

SECTION V1-V1 ("C" STACK, 8 PALLET UNITS)

STORAGE PROCEDURES FOR UNIT NO. 23

INTENTIONALLY LEFT BLANK FOR UNIT NO. 24

INTENTIONALLY LEFT BLANK FOR UNIT NO. 25

INTENTIONALLY LEFT BLANK FOR UNIT NO. 26

INTENTIONALLY LEFT BLANK FOR UNIT NO. 27

INTENTIONALLY LEFT BLANK FOR UNIT NO. 28

INTENTIONALLY LEFT BLANK FOR UNIT NO. 29

INTENTIONALLY LEFT BLANK FOR UNIT NO. 30

INTENTIONALLY LEFT BLANK

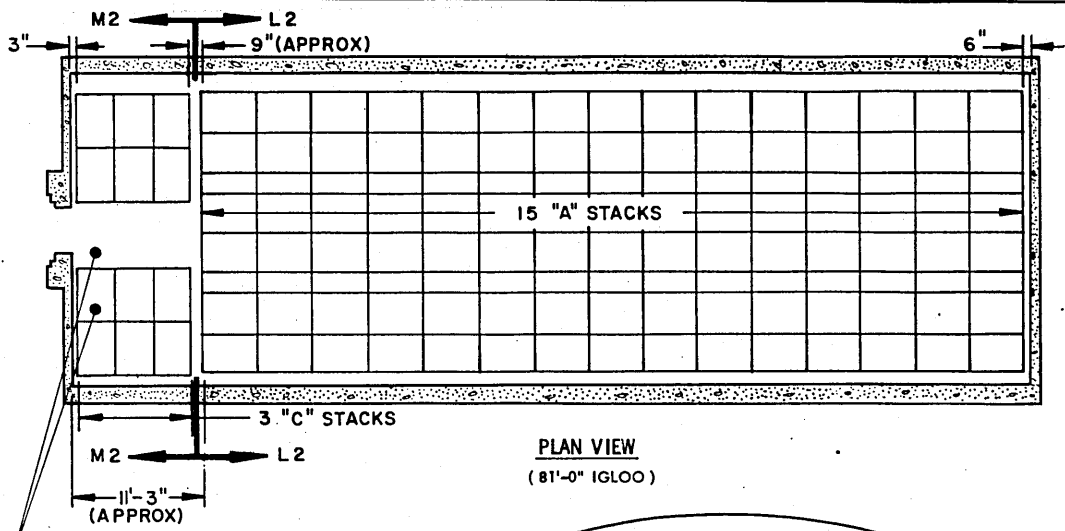

PLAN VIEW
(81'-0" IGLOO)

STORAGE IN 81'-0" IGLOO	
ITEM	QUANTITY
PALLET UNITS	321
* STORAGE IN 60'-8" IGLOO	
ITEM	QUANTITY
PALLET UNITS	228
* 10 A-STACKS	
4 C-STACKS	
** STORAGE IN 40'-4" IGLOO	
ITEM	QUANTITY
PALLET UNITS	141
** 6 A-STACKS	
3 C-STACKS	

SEE GENERAL NOTE "G" ON PAGE 2.

SEE GENERAL NOTE "D" ON PAGE 2.

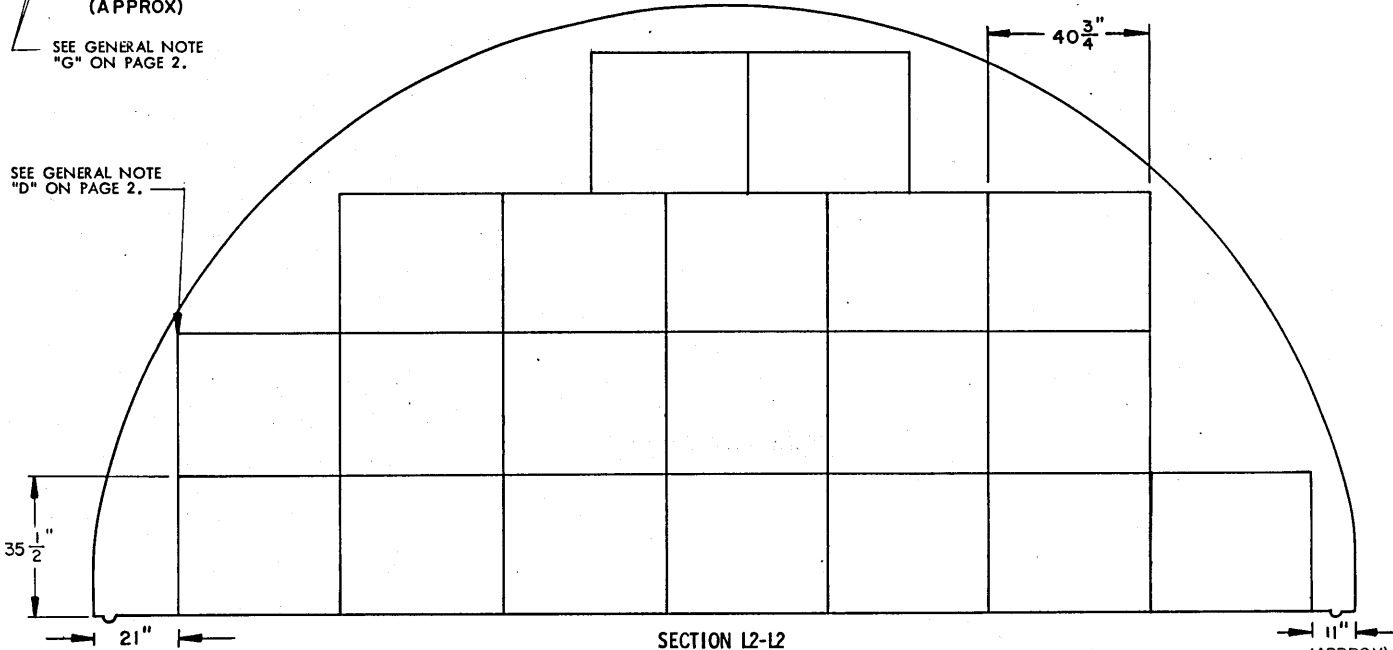

SECTION I2-I2
("A" STACK, 20 PALLET UNITS)

INDICATES OUTLINE OF DOOR OPENING.

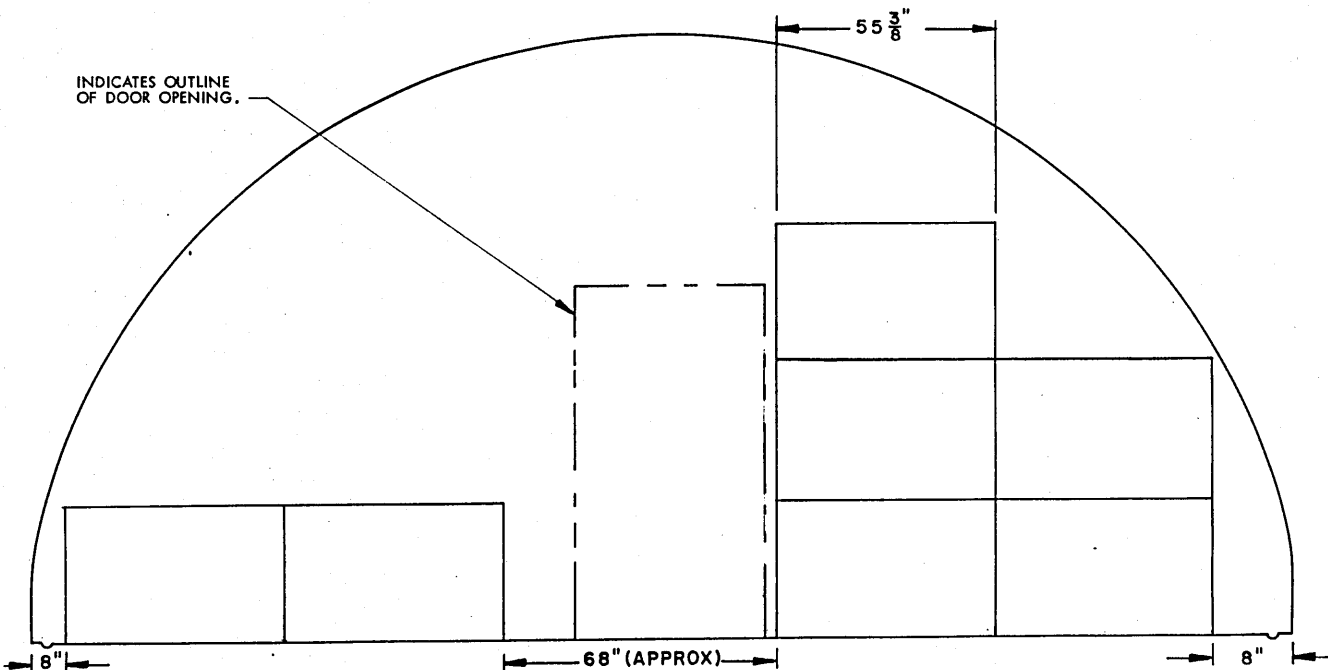

SECTION M2-M2 ("C" STACK, 7 PALLET UNITS)

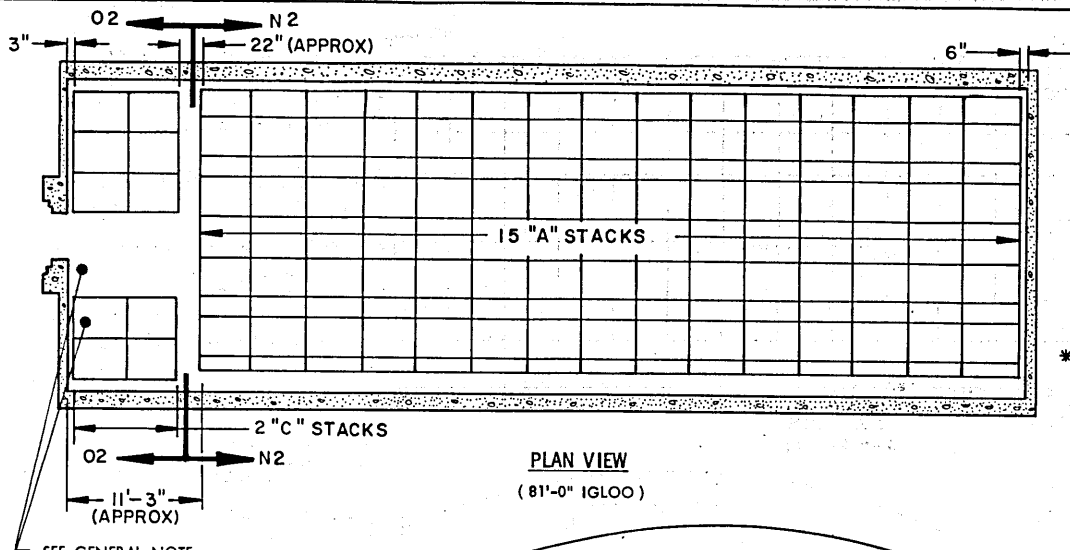

STORAGE IN 81'-0" IGLOO

ITEM	QUANTITY
PALLET UNITS	256

*** STORAGE IN 60'-8" IGLOO**

ITEM	QUANTITY
PALLET UNITS	176
* 10 A-STACKS	
2 C-STACKS	

**** STORAGE IN 40'-4" IGLOO**

ITEM	QUANTITY
PALLET UNITS	112
** 6 A-STACKS	
2 C-STACKS	

PLAN VIEW
(81'-0" IGLOO)

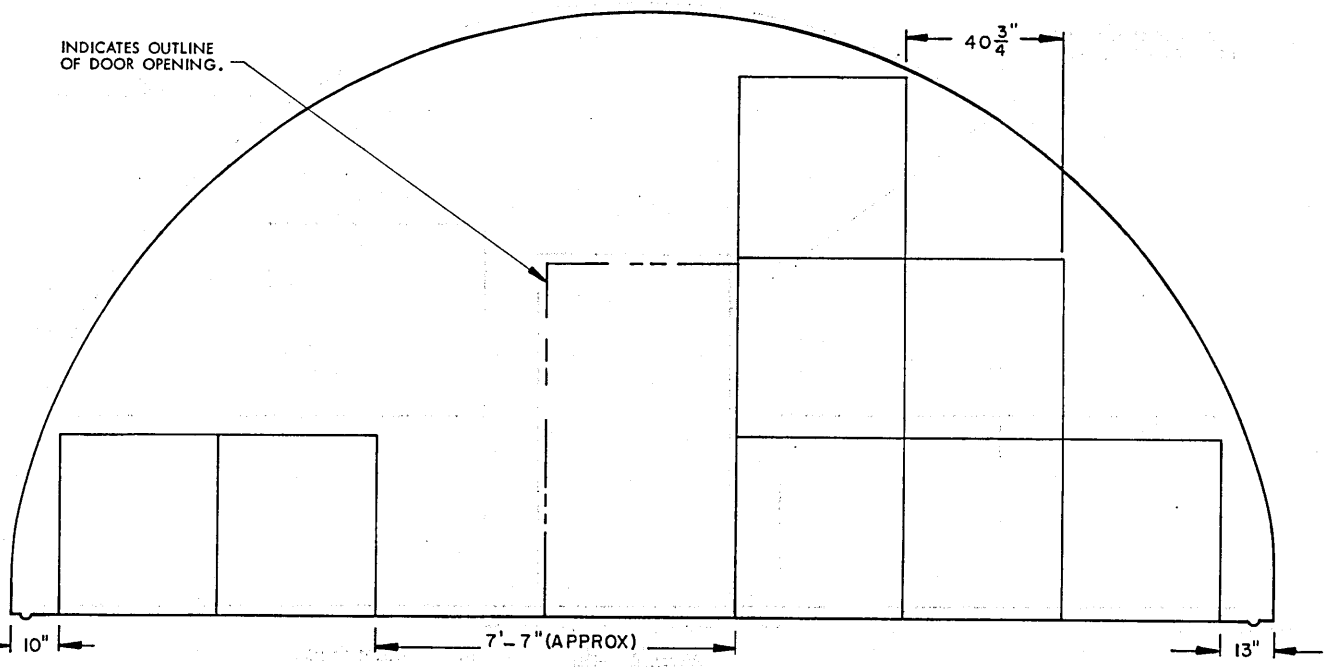
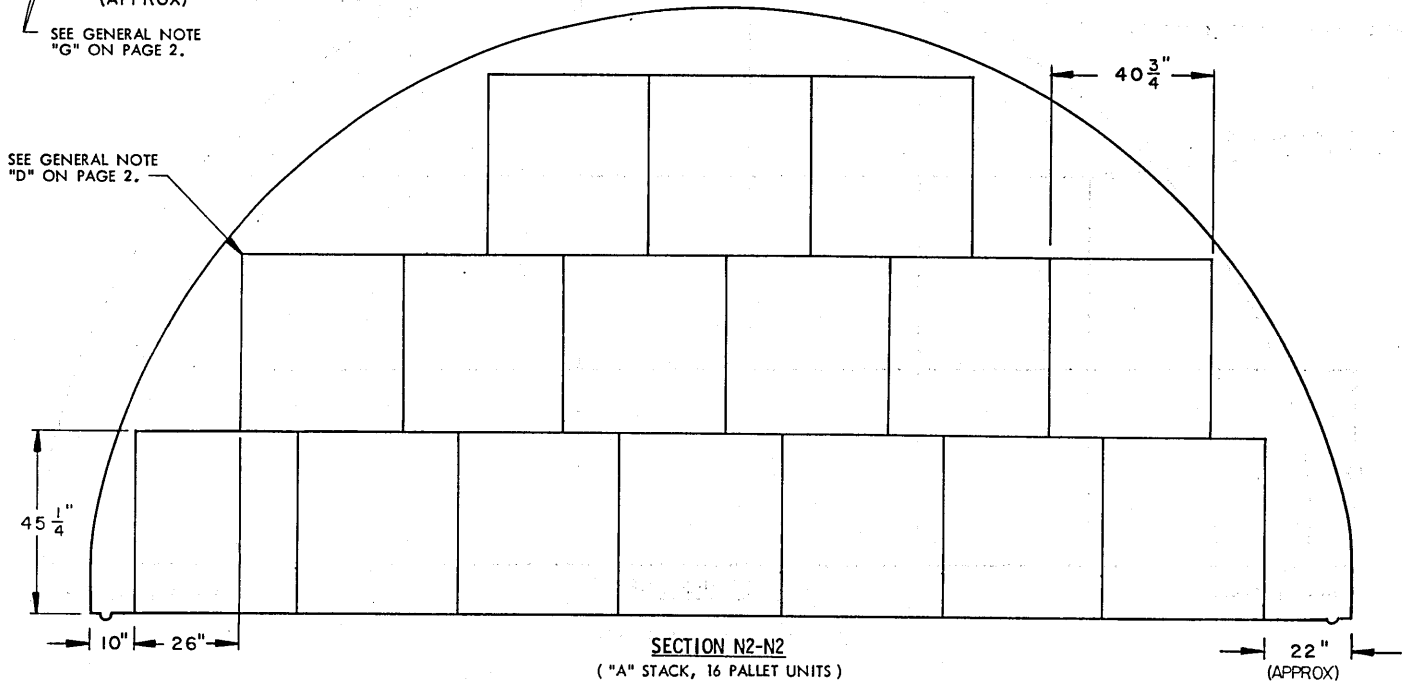

SECTION O2-O2 ("C" STACK, 8 PALLET UNITS)
STORAGE PROCEDURES FOR UNIT NO. 31 (INCREASED-HEIGHT UNIT)

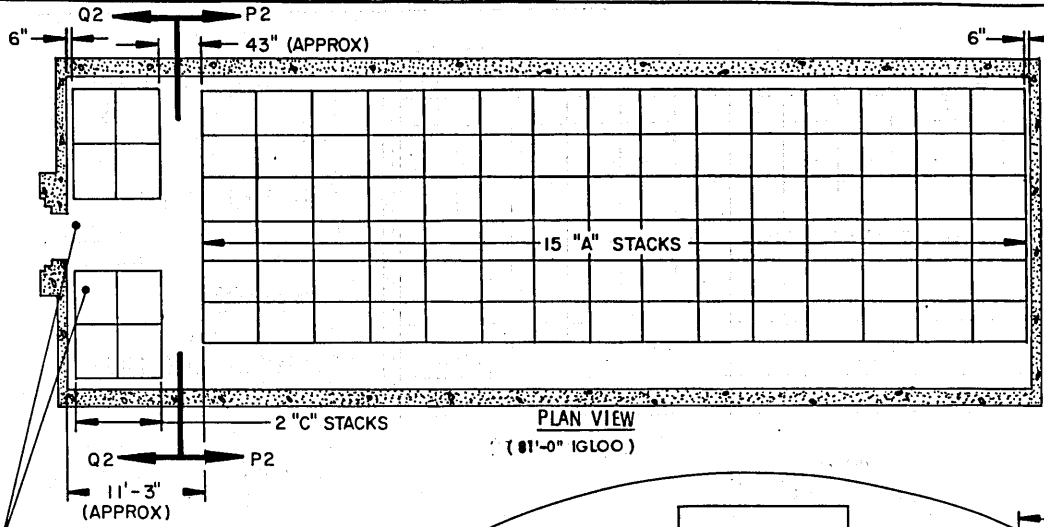

ITEM	QUANTITY
PALLET UNITS	190
STORAGE IN 60'-8" IGLOO	
* ITEM	QUANTITY
PALLET UNITS	135
* 10 A-STACKS	
3 C-STACKS	
** STORAGE IN 40'-4" IGLOO	
ITEM	QUANTITY
PALLET UNITS	87
** 6 A-STACKS	
3 C-STACKS	

SEE GENERAL NOTE "G" ON PAGE 2

SEE GENERAL NOTE "D" ON PAGE 2.

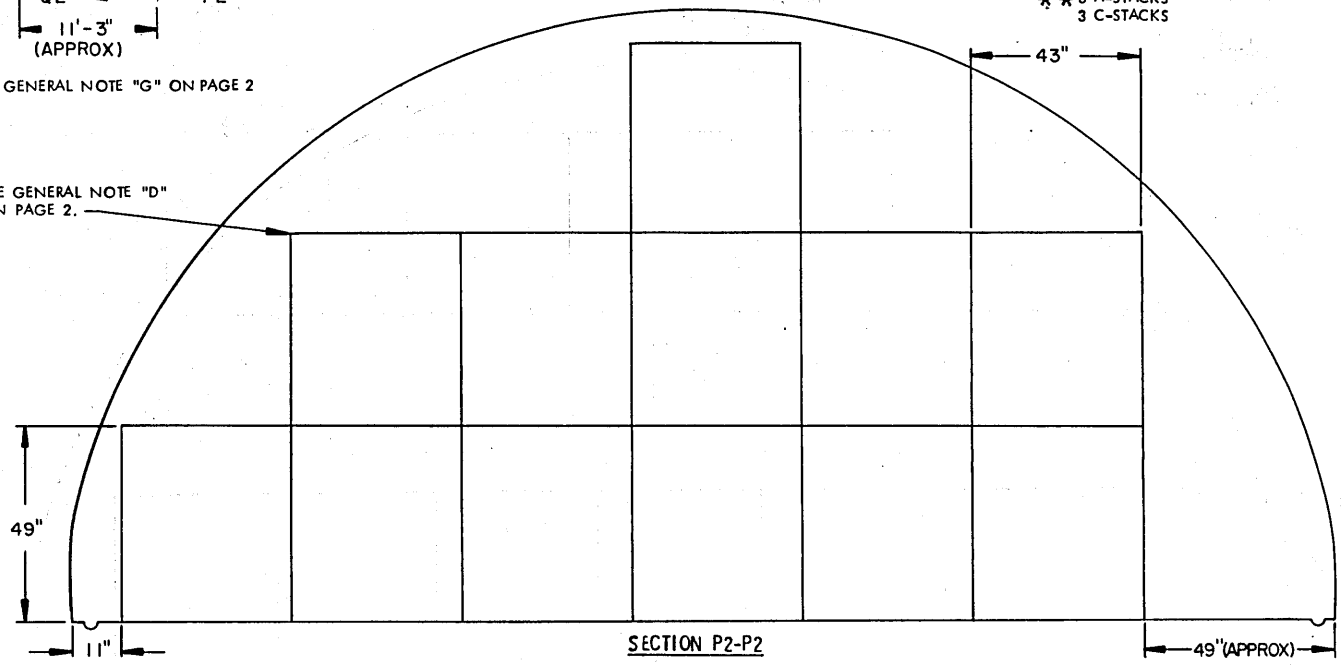

INDICATES OUTLINE OF DOOR OPENING.

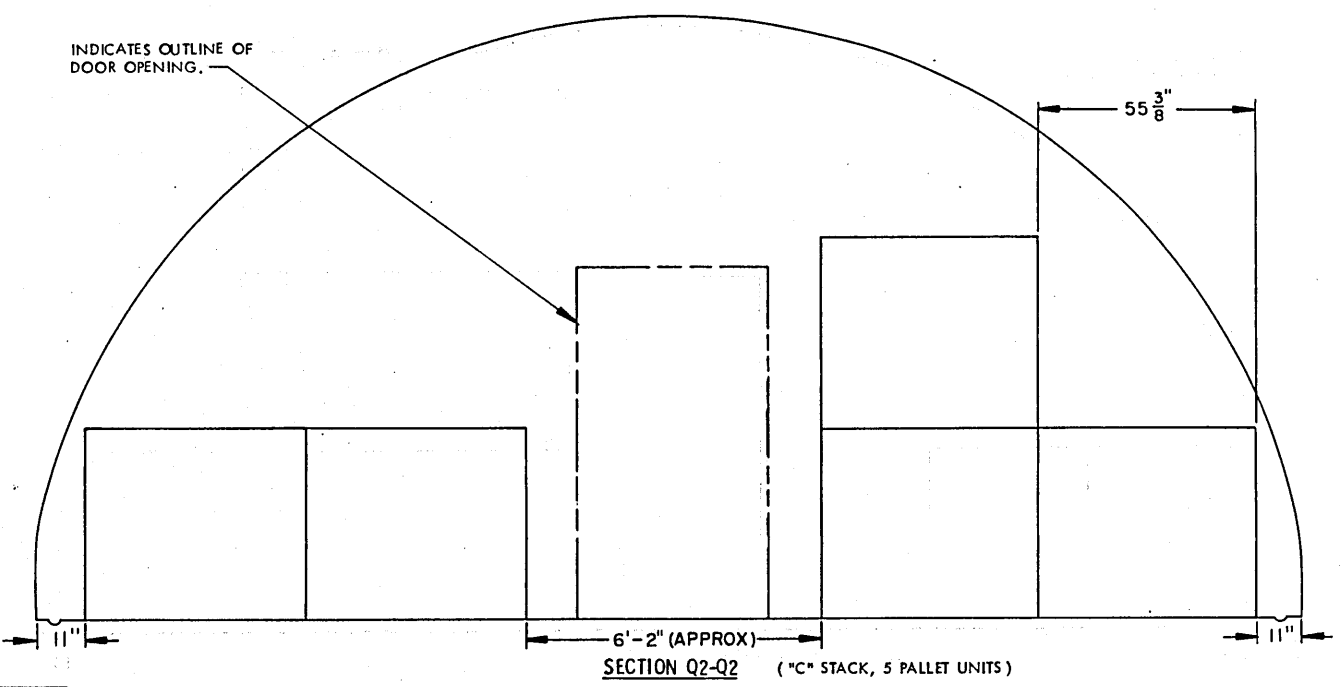

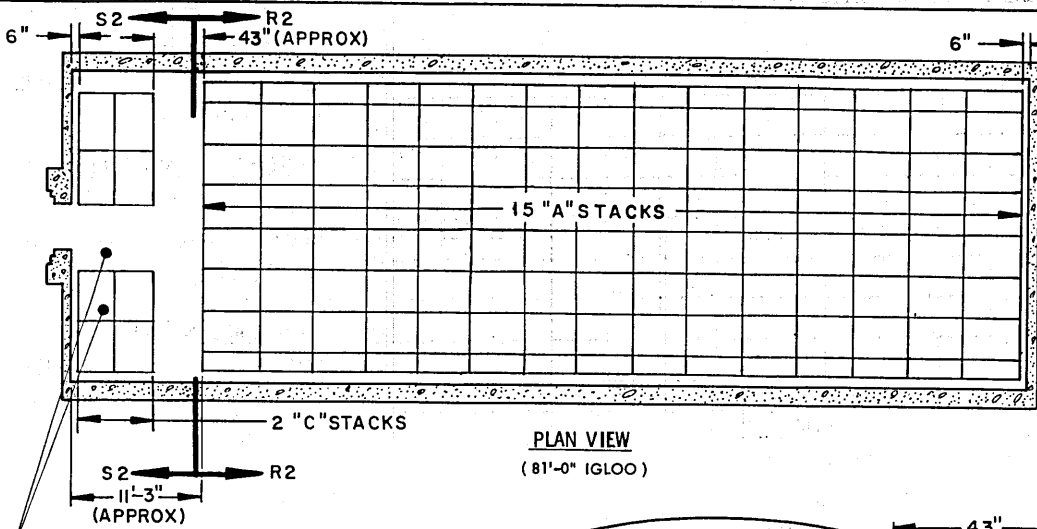

STORAGE IN 81'-0" IGLOO	
ITEM	QUANTITY
PALLET UNITS	269
* STORAGE IN 60'-8" IGLOO	
ITEM	QUANTITY
PALLET UNITS	191
* 10 A-STACKS	
3 C-STACKS	
** STORAGE IN 40'-4" IGLOO	
ITEM	QUANTITY
PALLET UNITS	123
** 6 A-STACKS	
3 C-STACKS	

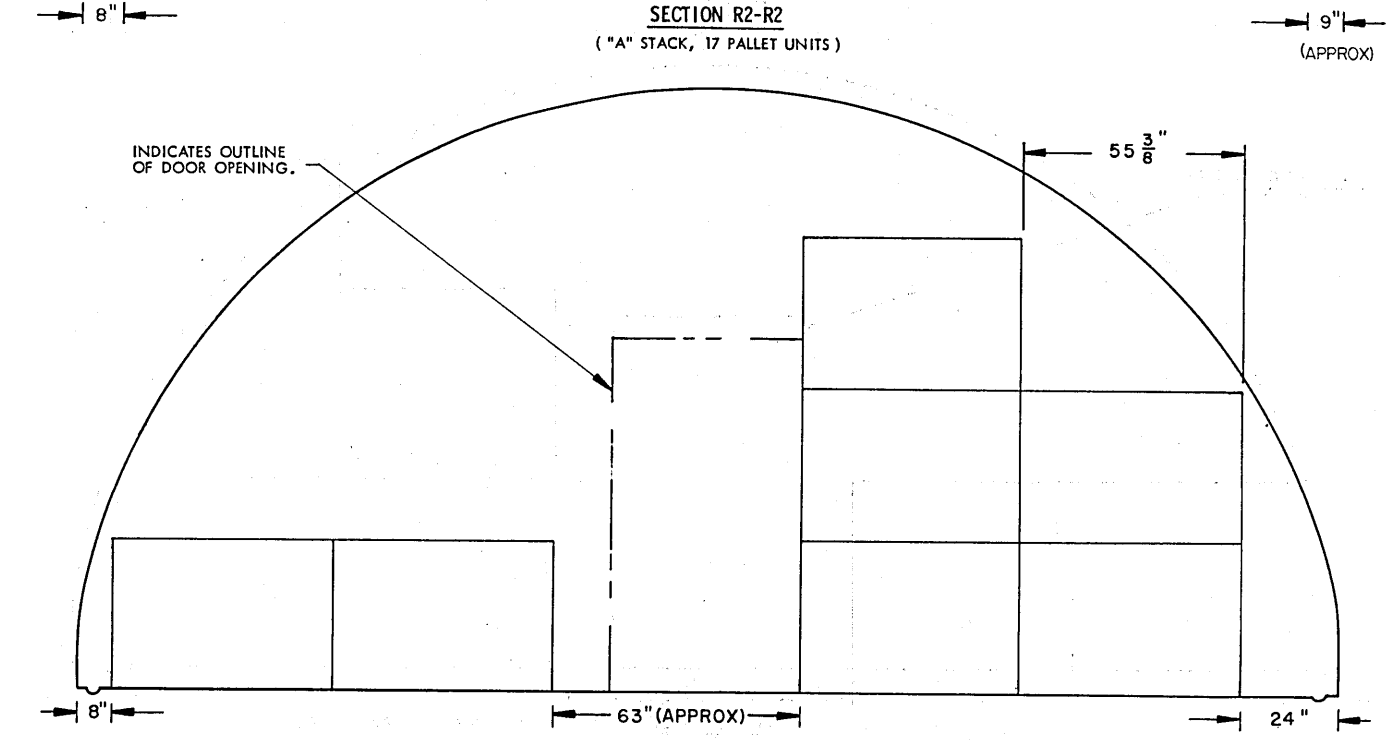
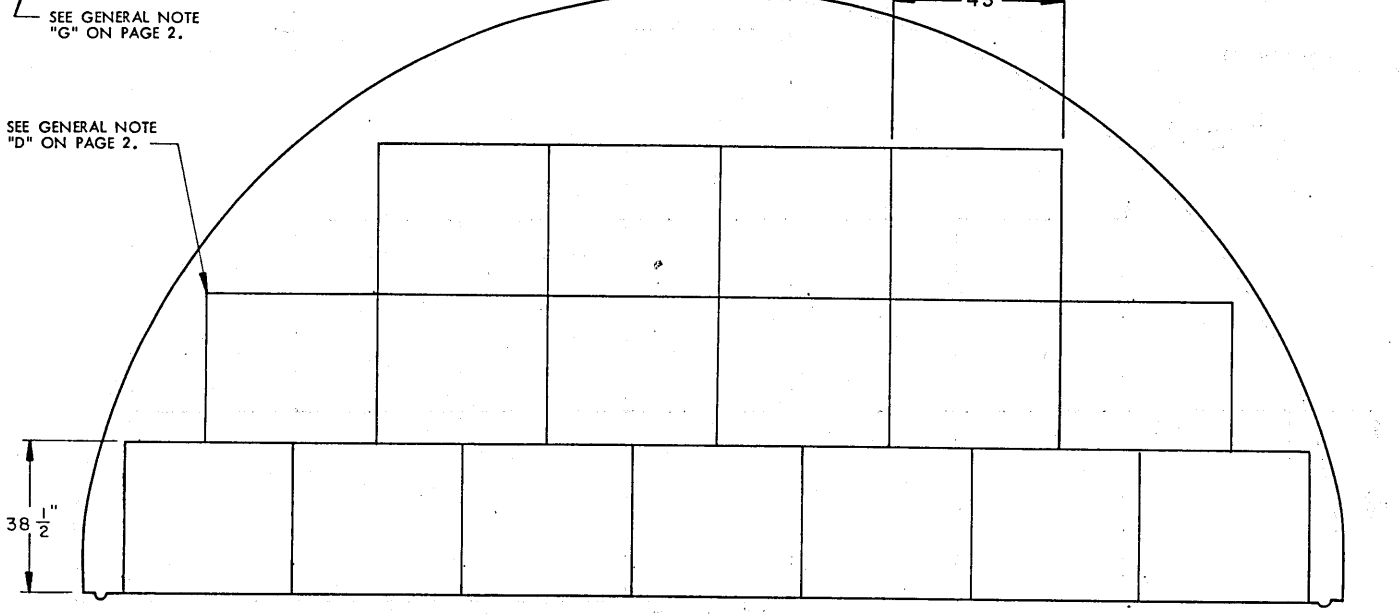

STORAGE PROCEDURES FOR UNIT NO. 32 (DECREASED-HEIGHT UNIT)

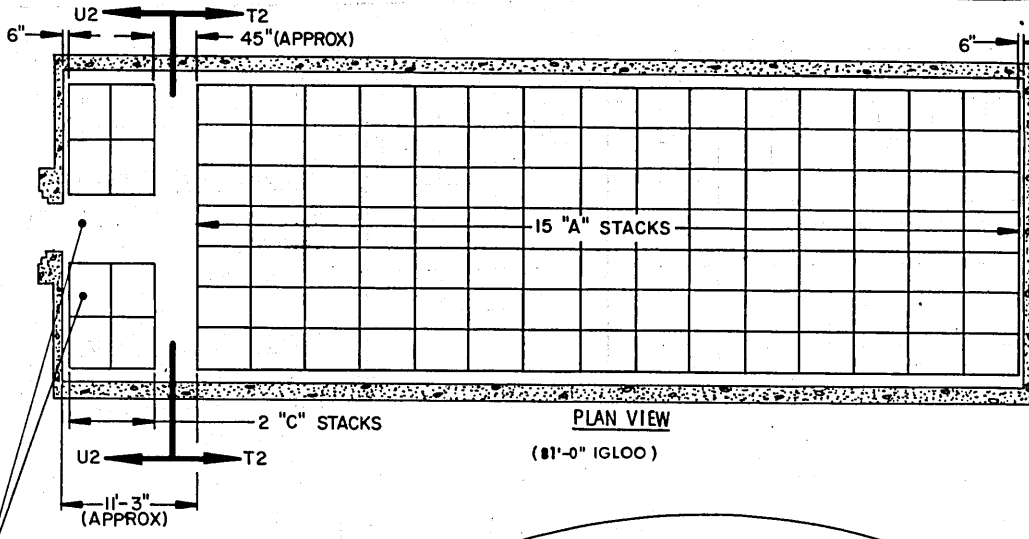

STORAGE IN 81'-0" IGLOO	
ITEM	QUANTITY
PALLET UNITS-----	205
* STORAGE IN 60'-8" IGLOO	
ITEM	QUANTITY
PALLET UNITS-----	145
* 10 A-STACKS	
3 C-STACKS	
** STORAGE IN 40'-4" IGLOO	
ITEM	QUANTITY
PALLET UNITS-----	93
* 6 A-STACKS	
3 C-STACKS	

SEE GENERAL NOTE "G" ON PAGE 2.

SEE GENERAL NOTE "D" ON PAGE 2.

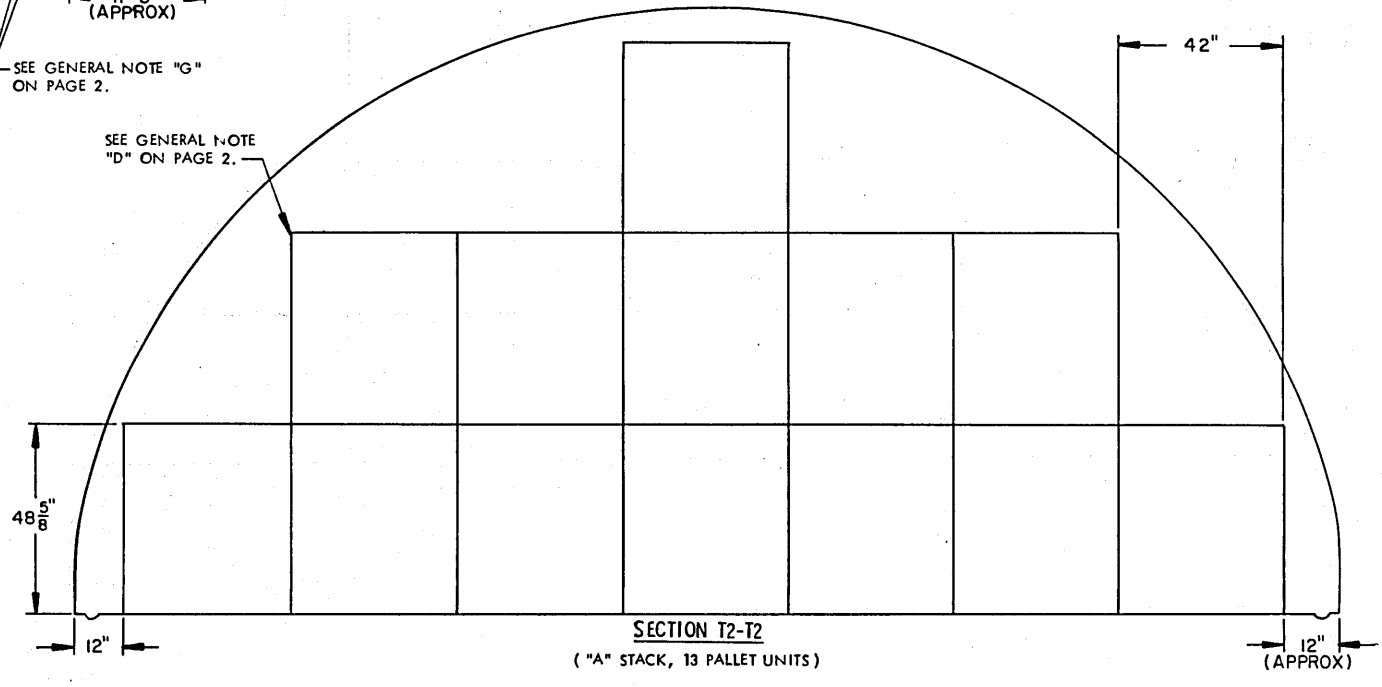

INDICATES OUTLINE OF DOOR OPENING.

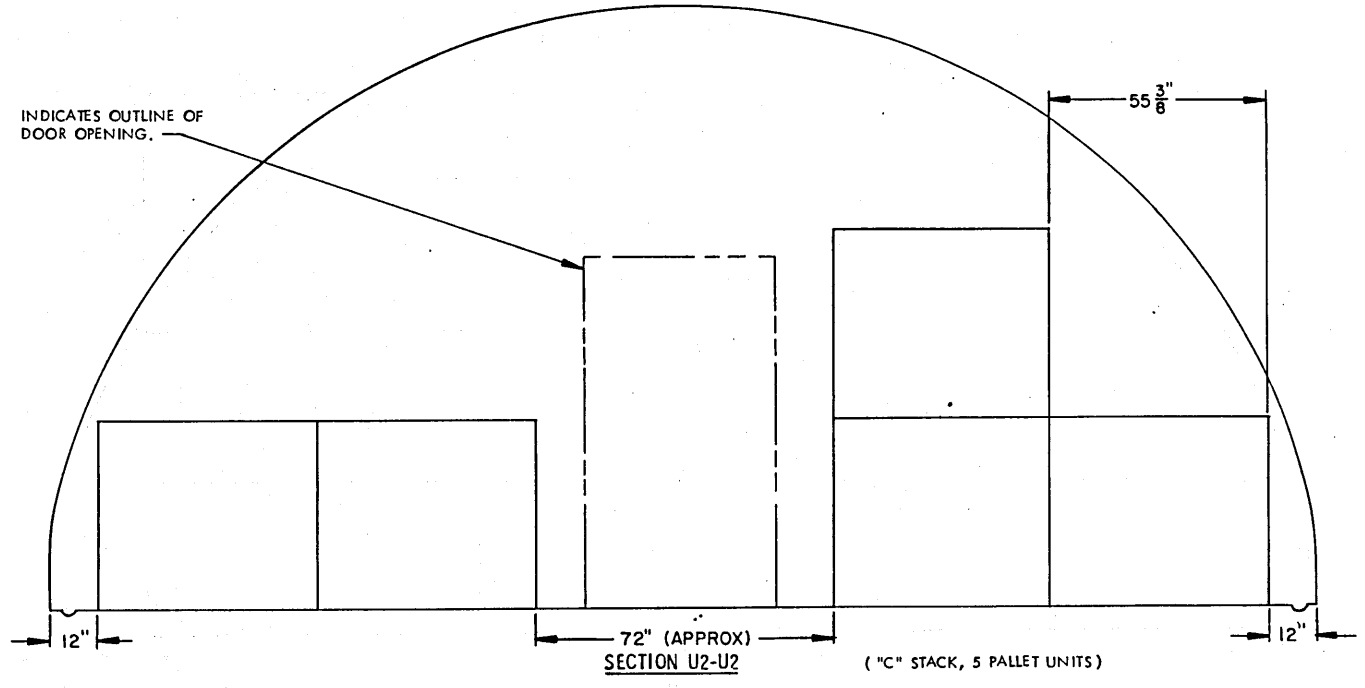

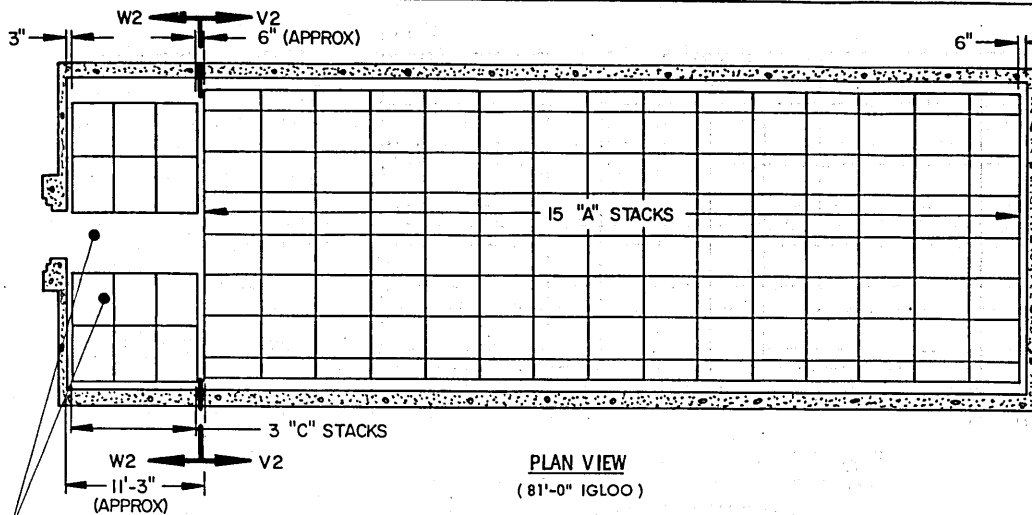

STORAGE IN 81'-0' IGLOO	
ITEM	QUANTITY
PALLET UNITS	276
* STORAGE IN 60'-8' IGLOO	
ITEM	QUANTITY
PALLET UNITS	191
* 10 A-STACKS	
3 C-STACKS	
** STORAGE IN 40'-4" IGLOO	
ITEM	QUANTITY
PALLET UNITS	116
** 6 A-STACKS	
2 C-STACKS	

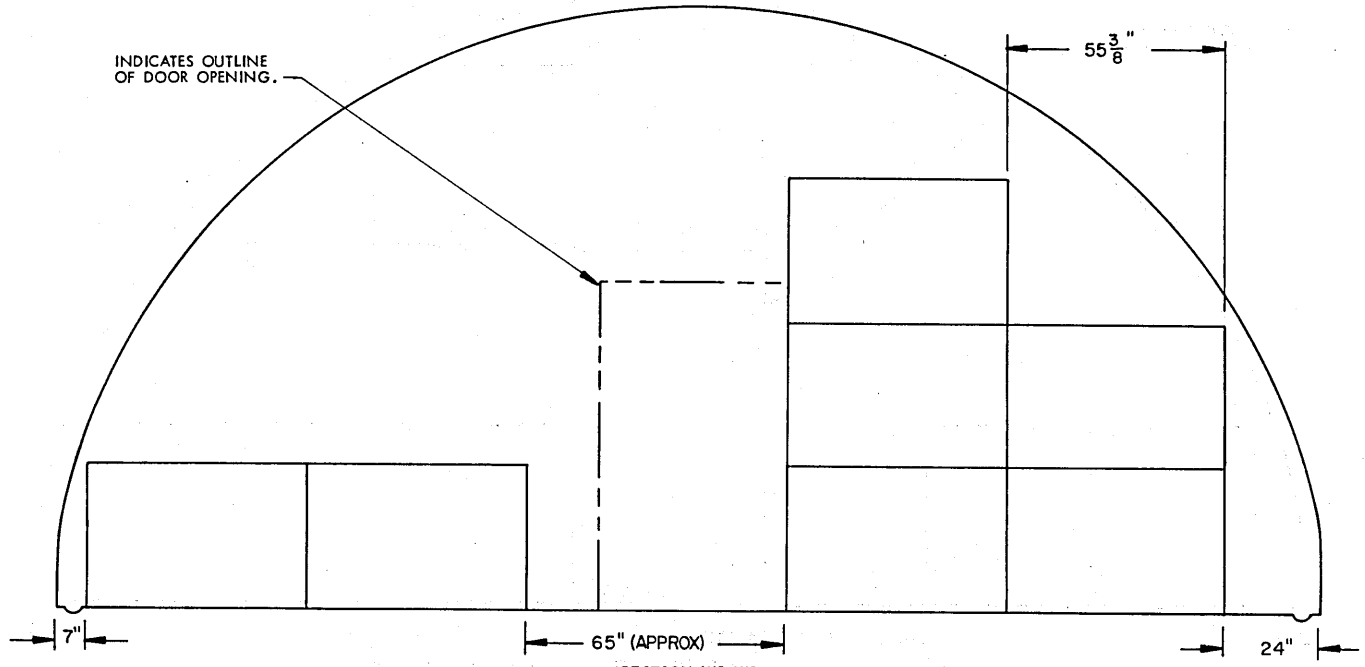
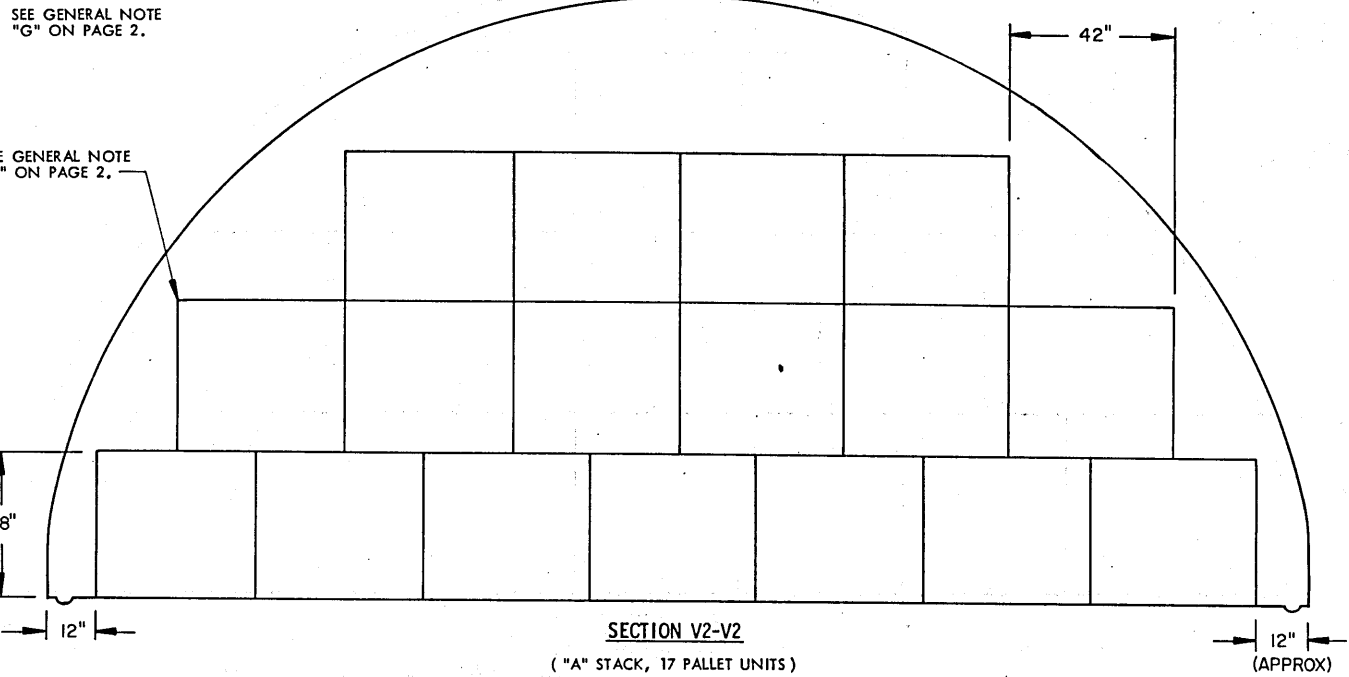

STORAGE PROCEDURES FOR UNIT NO. 33 (DECREASED-HEIGHT UNIT)

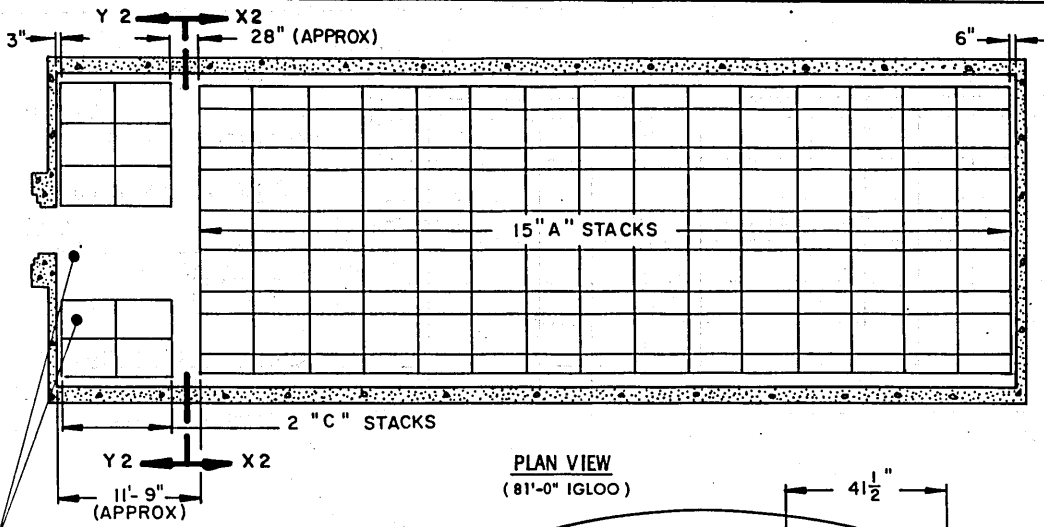

STORAGE IN 81'-0" IGLOO

ITEM	QUANTITY
PALLET UNITS	256

*** STORAGE IN 60'-8" IGLOO**

ITEM	QUANTITY
PALLET UNITS	184
* 10 A-STACKS	
3 C-STACKS	

**** STORAGE IN 40'-4" IGLOO**

ITEM	QUANTITY
PALLET UNITS	112
* 6 A-STACKS	
2 C-STACKS	

PLAN VIEW
(81'-0" IGLOO)

SEE GENERAL NOTE "G" ON PAGE 2.

SEE GENERAL NOTE "D" ON PAGE 2.

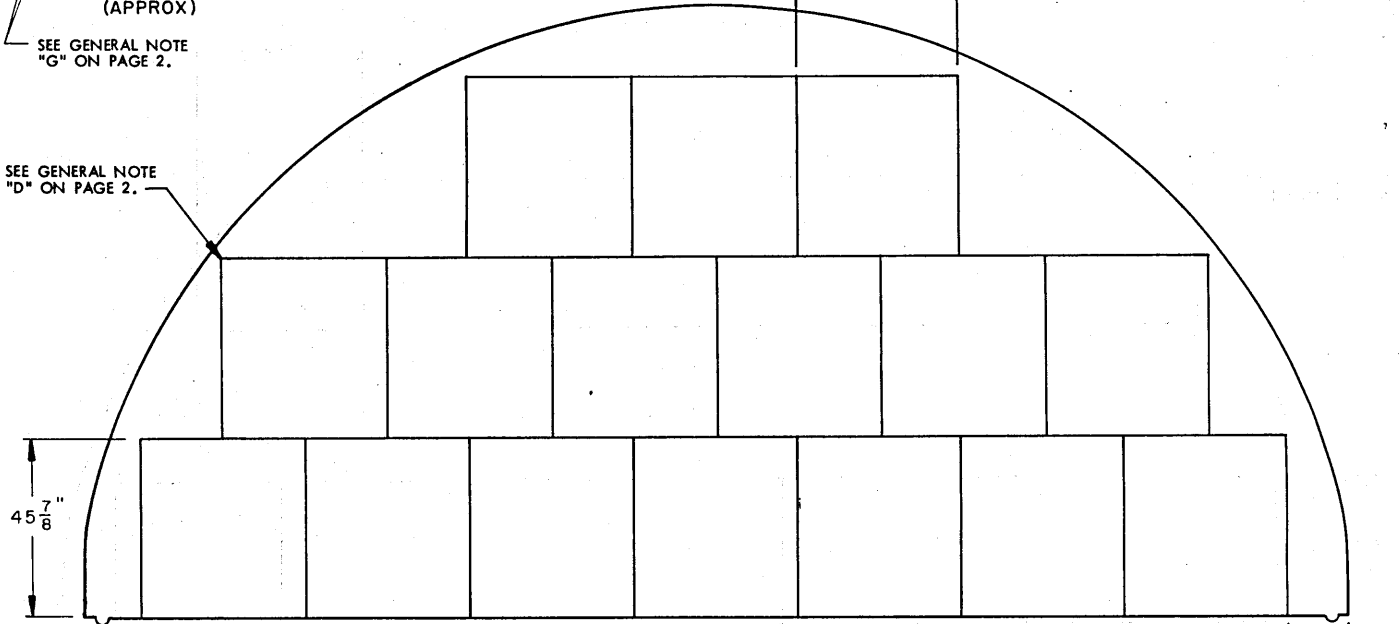

SECTION X2-X2
("A" STACK, 16 PALLET UNITS)

INDICATES OUTLINE OF DOOR OPENING.

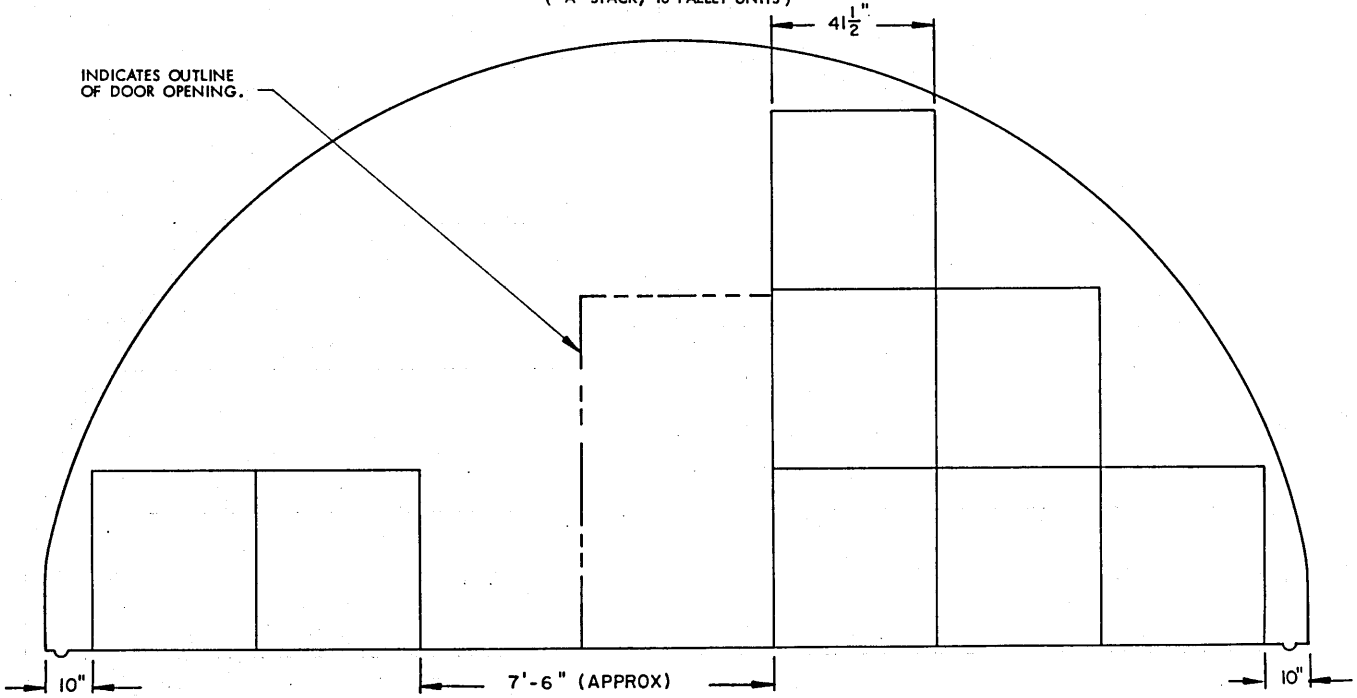

SECTION Y2-Y2 ("C" STACK, 8 PALLET UNITS)

STORAGE PROCEDURES FOR UNIT NO. 34

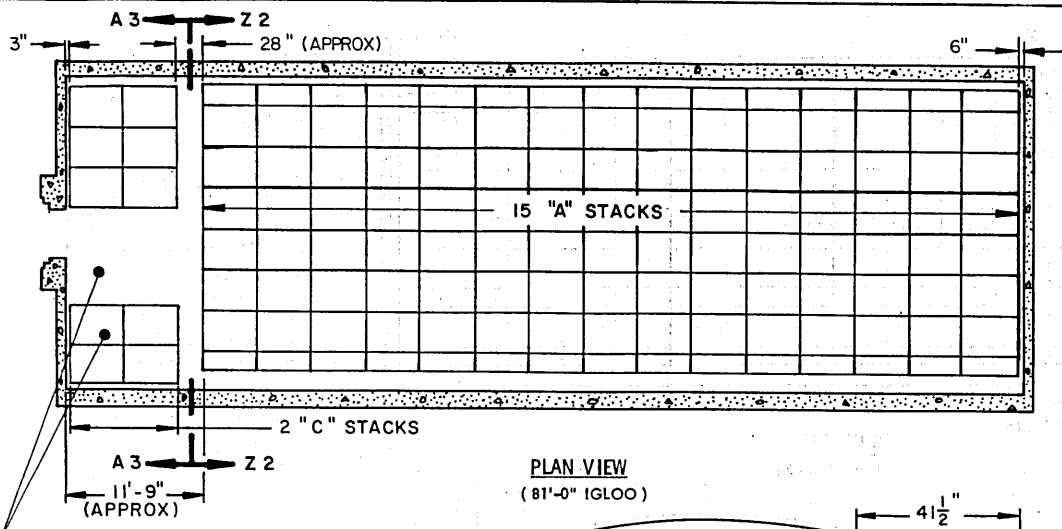

STORAGE IN 81'-0" IGLOO

ITEM	QUANTITY
PALLET UNITS	271

*** STORAGE IN 60'-8" IGLOO**

ITEM	QUANTITY
PALLET UNITS	194
* 10 A-STACKS	
3 C-STACKS	

**** STORAGE IN 40'-4" IGLOO**

ITEM	QUANTITY
PALLET UNITS	118
** 6 A-STACKS	
2 C-STACKS	

PLAN VIEW
(81'-0" IGLOO)

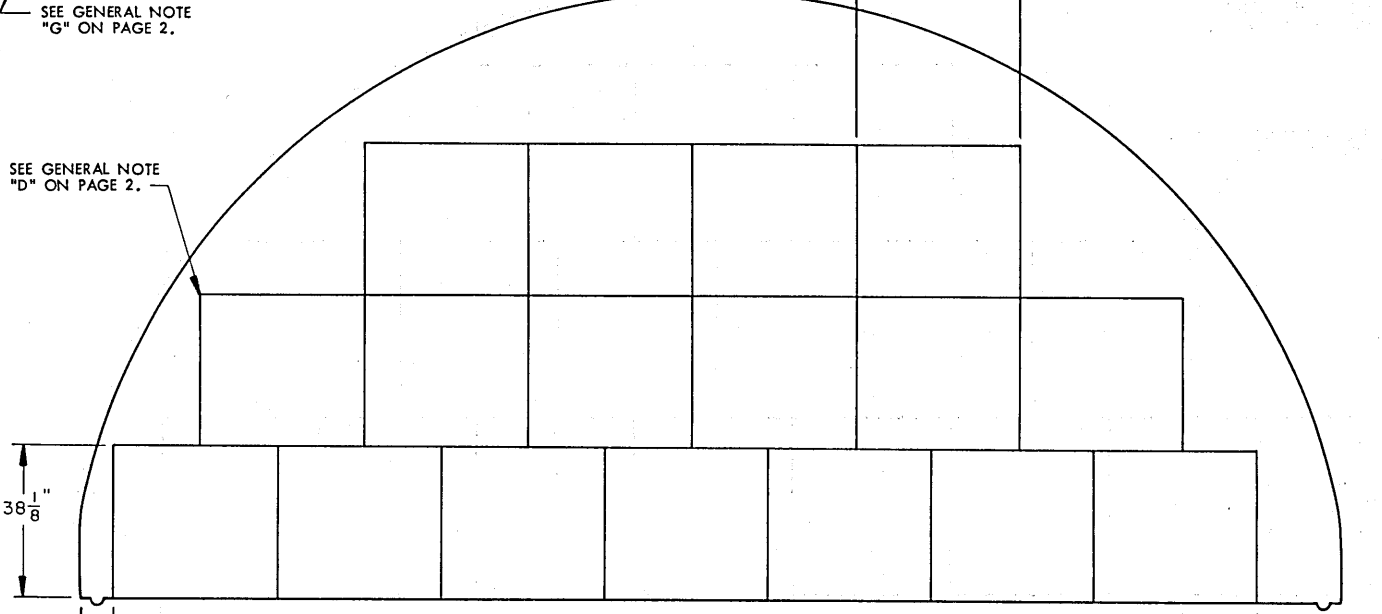

SECTION Z2-Z2
("A" STACK, 17 PALLET UNITS)

INDICATES OUTLINE OF DOOR OPENING.

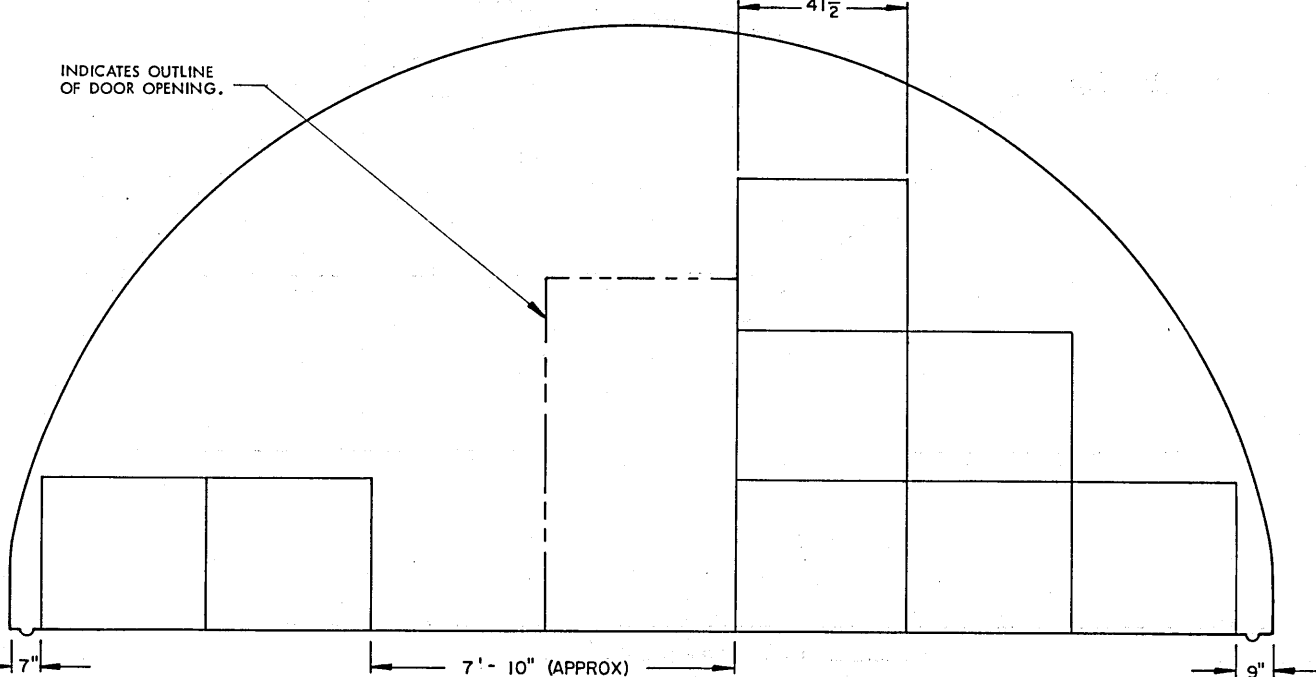

SECTION A3-A3 ("C" STACK, 8 PALLET UNITS)

STORAGE PROCEDURES FOR UNIT NO. 34 (DECREASED-HEIGHT UNIT)

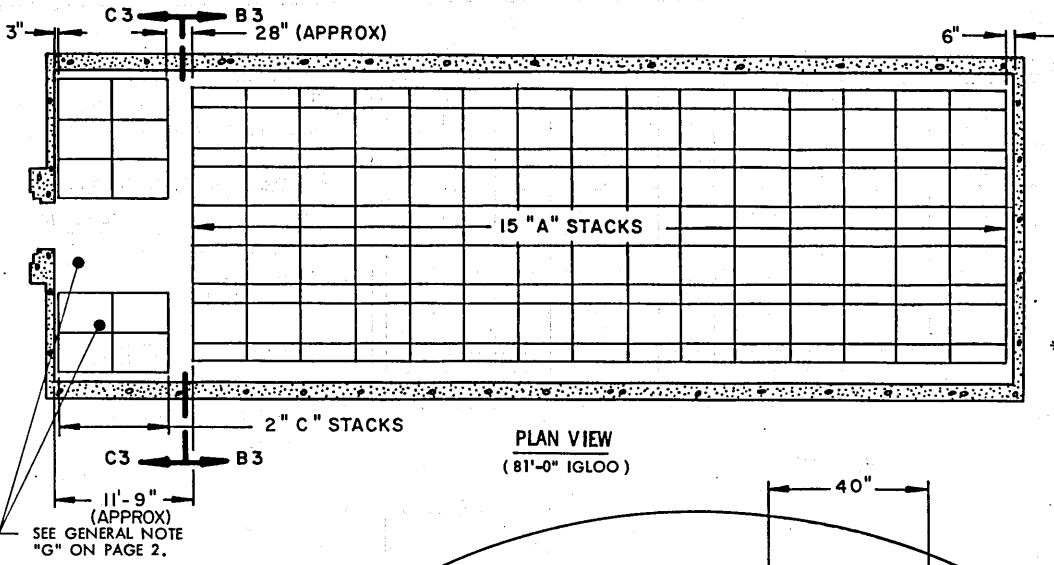

PLAN VIEW
(81'-0" IGLOO)

STORAGE IN 81'-0" IGLOO

ITEM	QUANTITY
PALLET UNITS	256

* STORAGE IN 60'-8" IGLOO

ITEM	QUANTITY
PALLET UNITS	184
* 10 A-STACKS	
3 C-STACKS	

** STORAGE IN 40'-4" IGLOO

ITEM	QUANTITY
PALLET UNITS	112
** 6 A-STACKS	
2 C-STACKS	

SEE GENERAL NOTE "D" ON PAGE 2.

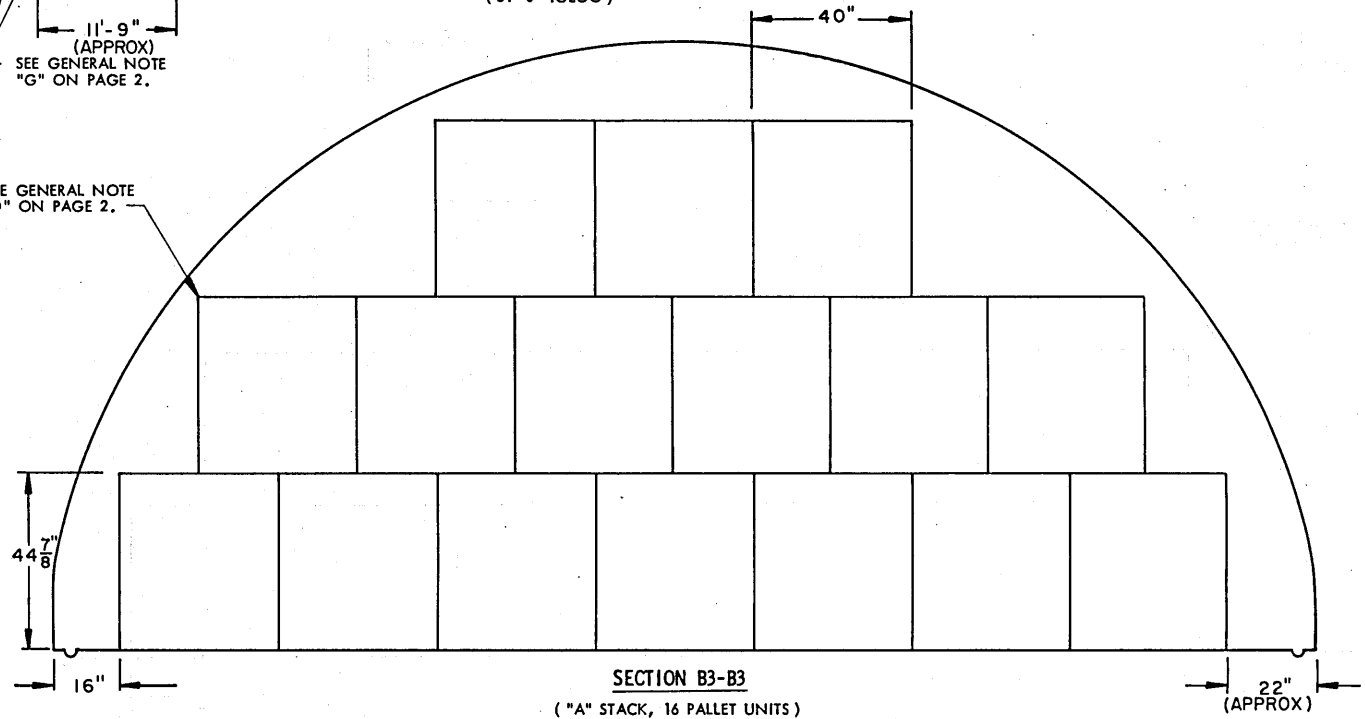

SECTION B3-B3
("A" STACK, 16 PALLET UNITS)

INDICATES OUTLINE OF DOOR OPENING.

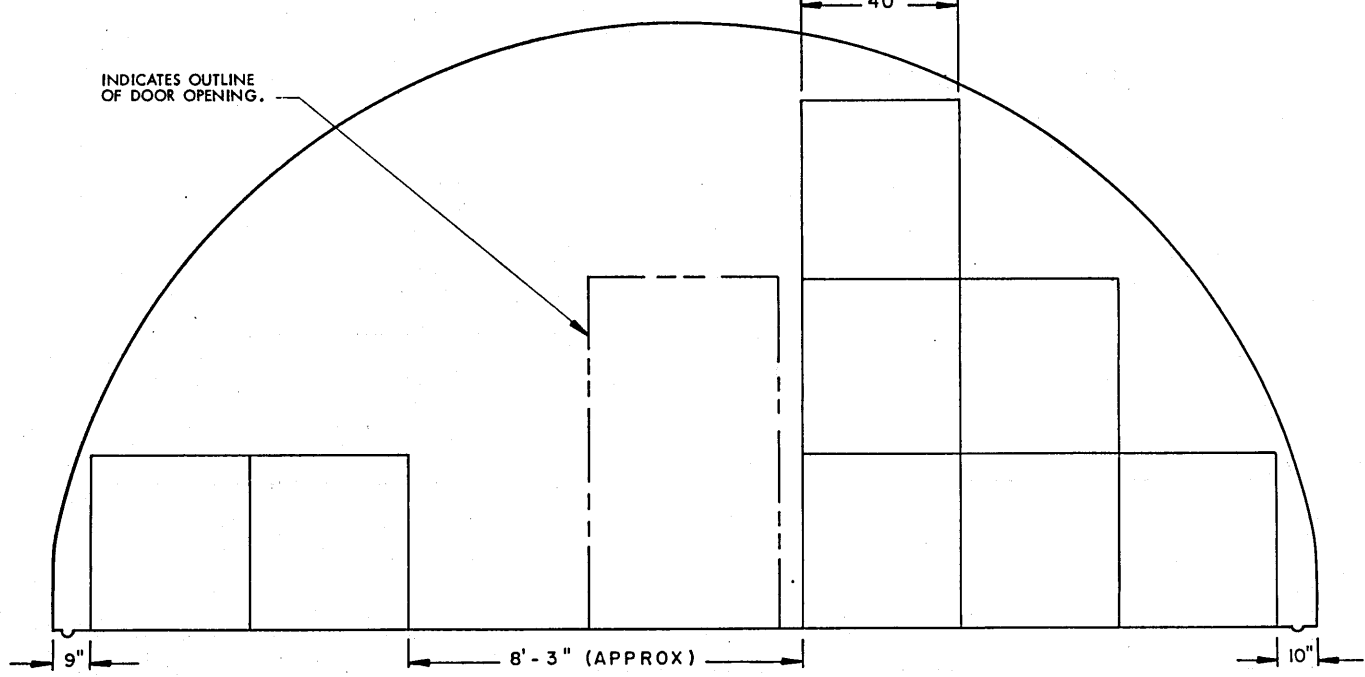

SECTION C3-C3 ("C" STACK, 8 PALLET UNITS)
STORAGE PROCEDURES FOR UNIT NO. 35

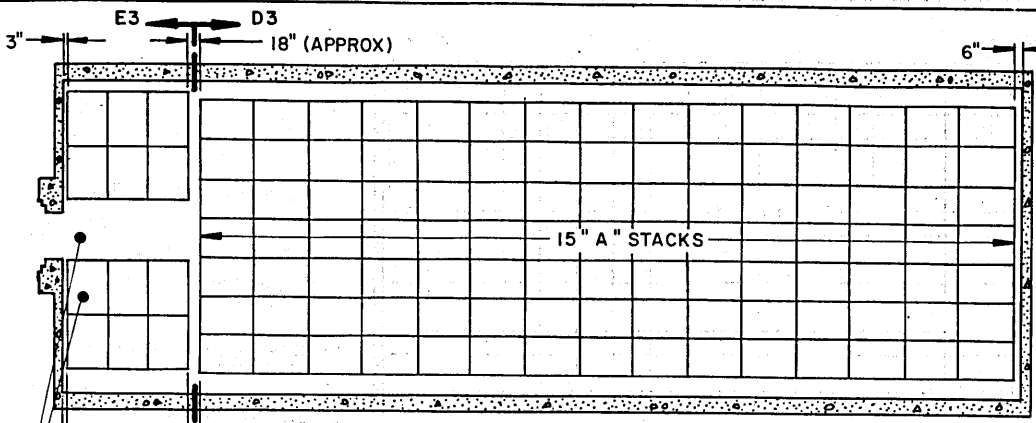

STORAGE IN 81'-0" IGLOO

ITEM	QUANTITY
PALLET UNITS	306

*** STORAGE IN 60'-8" IGLOO**

ITEM	QUANTITY
PALLET UNITS	218
* 10 A-STACKS	
4 C-STACKS	

**** STORAGE IN 40'-4" IGLOO**

ITEM	QUANTITY
PALLET UNITS	135
* 6 A-STACKS	
3 C-STACKS	

PLAN VIEW
(81'-0" IGLOO)

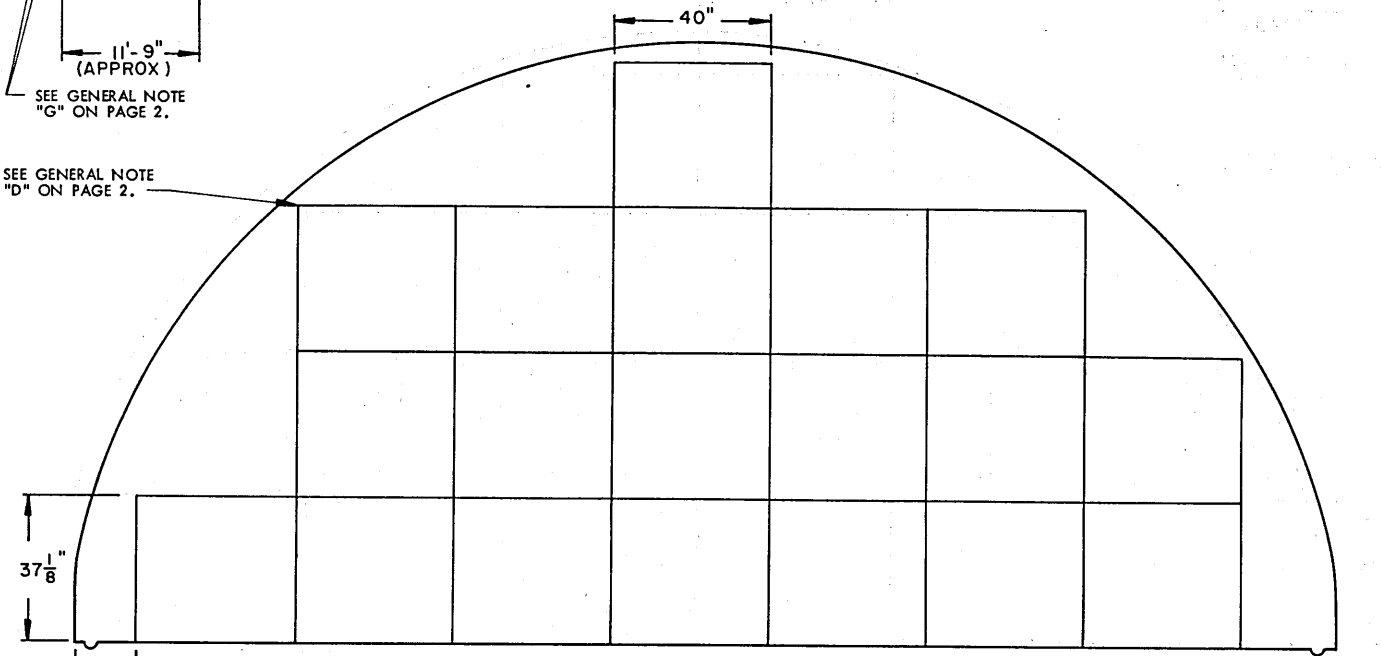

SECTION D3-D3
("A" STACK, 19 PALLET UNITS)

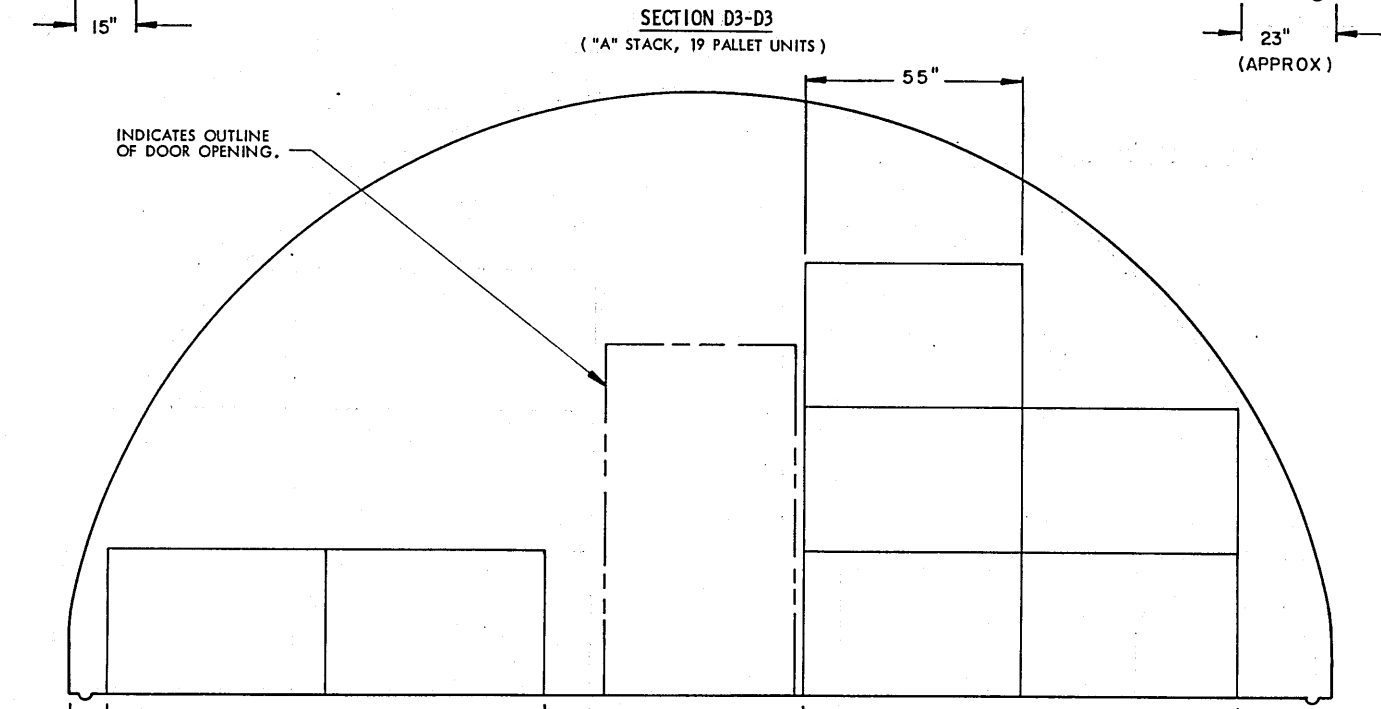

SECTION E3-E3 ("C" STACK, 7 PALLET UNITS)

STORAGE PROCEDURES FOR UNIT NO. 35 (DECREASED-HEIGHT UNIT)

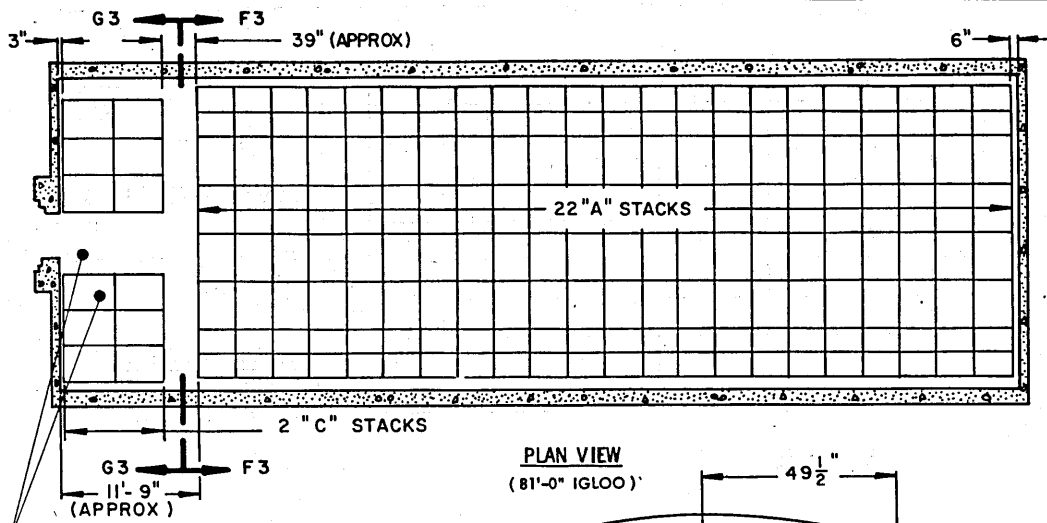

STORAGE IN 81'-0" IGLOO

ITEM	QUANTITY
PALLET UNITS	396

*** STORAGE IN 60'-8" IGLOO**

ITEM	QUANTITY
PALLET UNITS	288
* 15 A-STACKS	
3 C-STACKS	

**** STORAGE IN 40'-4" IGLOO**

ITEM	QUANTITY
PALLET UNITS	175
** 9 A-STACKS	
2 C-STACKS	

PLAN VIEW
(81'-0" IGLOO)

SEE GENERAL NOTE "G" ON PAGE 2.

SEE GENERAL NOTE "D" ON PAGE 2.

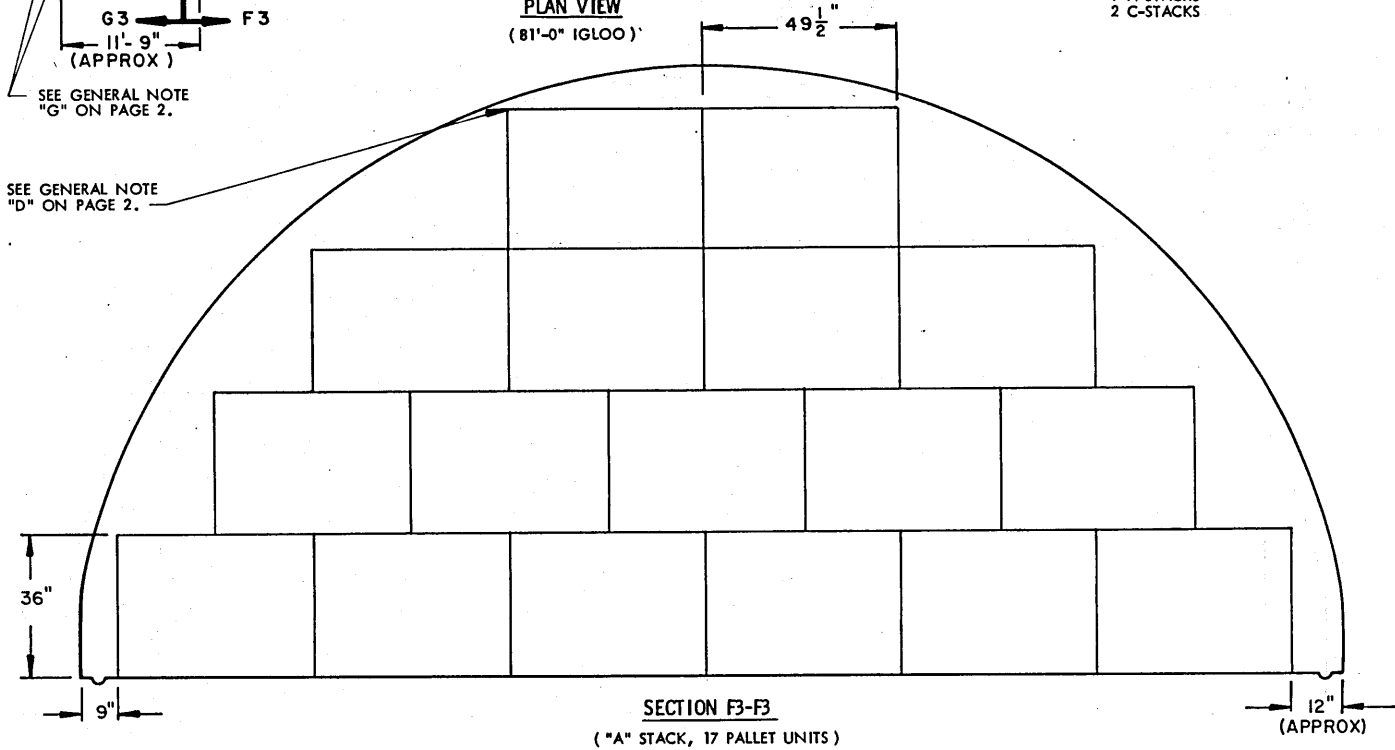

SECTION F3-F3
("A" STACK, 17 PALLET UNITS)

INDICATES OUTLINE OF DOOR OPENING.

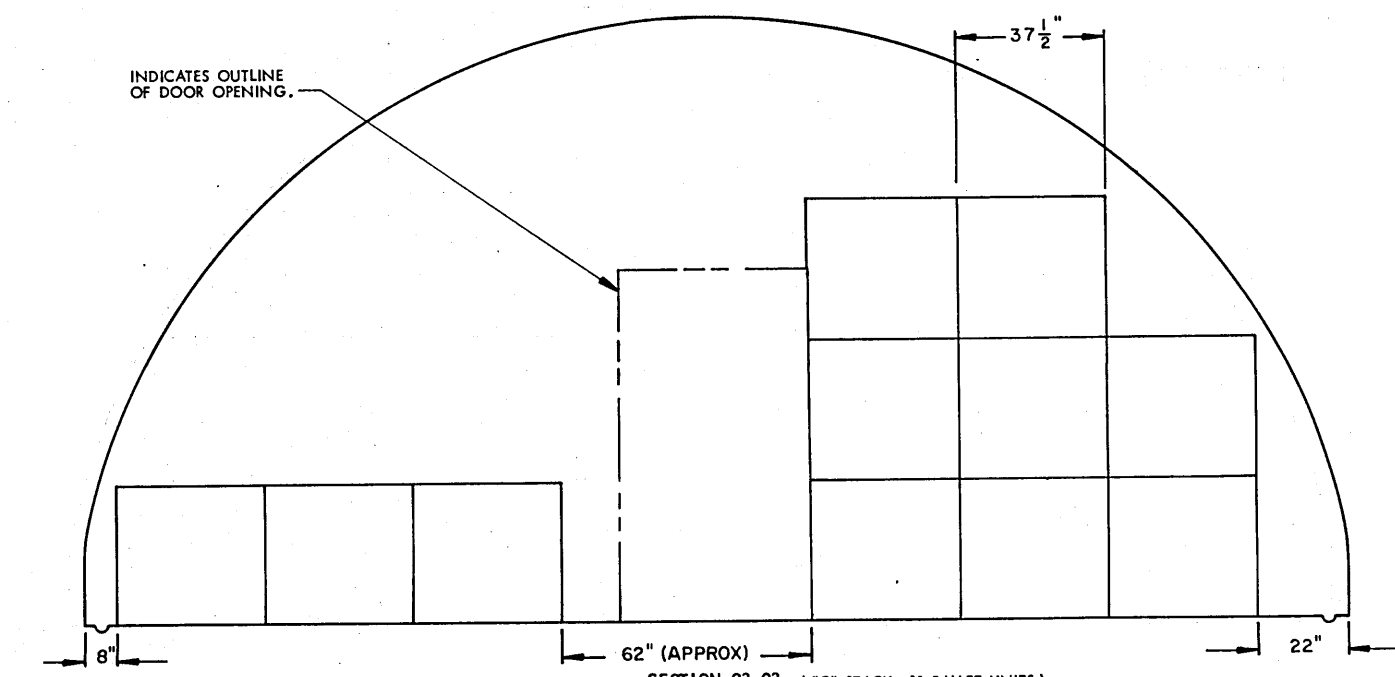

SECTION G3-G3 ("C" STACK, 11 PALLET UNITS)
STORAGE PROCEDURES FOR UNIT NO. 36

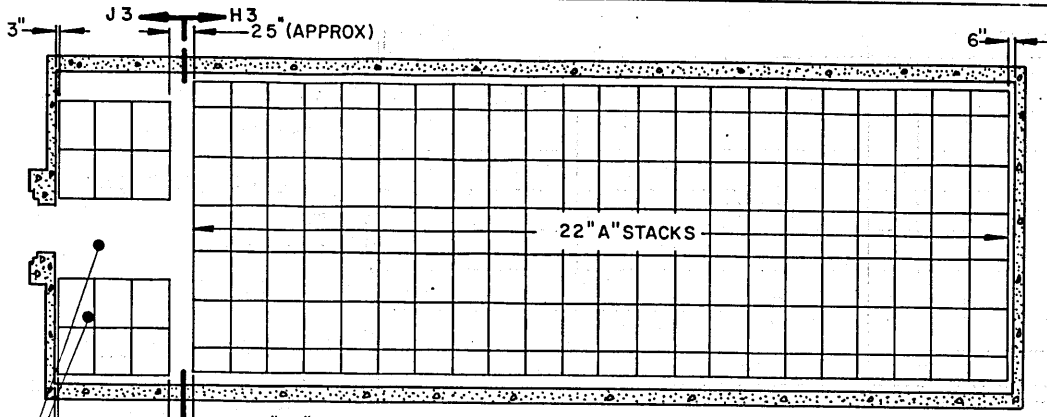

PLAN VIEW
(81'-0" IGLOO)

STORAGE IN 81'-0" IGLOO	
ITEM	QUANTITY
PALLET UNITS	----- 329
* STORAGE IN 60'-8" IGLOO	
ITEM	QUANTITY
PALLET UNITS	----- 231
* 15 A-STACKS	
3 C-STACKS	
** STORAGE IN 40'-4" IGLOO	
ITEM	QUANTITY
PALLET UNITS	----- 147
** 9 A-STACKS	
3 C-STACKS	

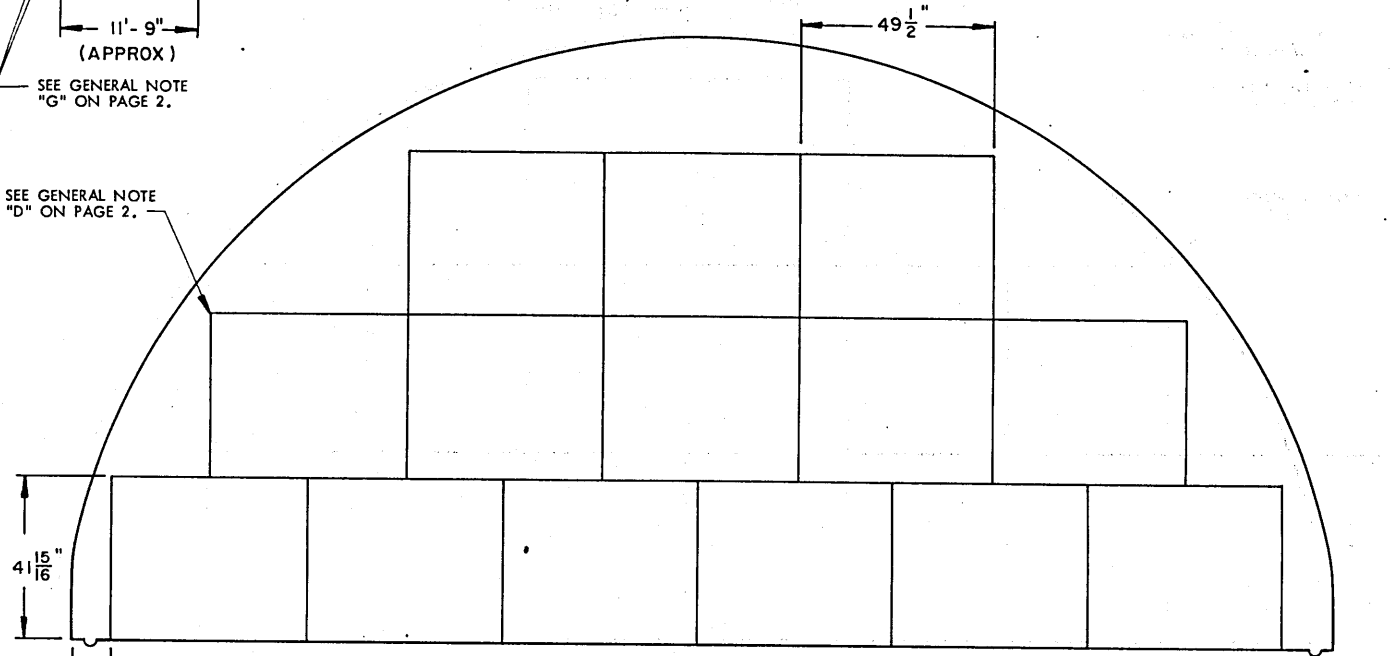

SECTION H3-H3
("A" STACK, 14 PALLET UNITS)

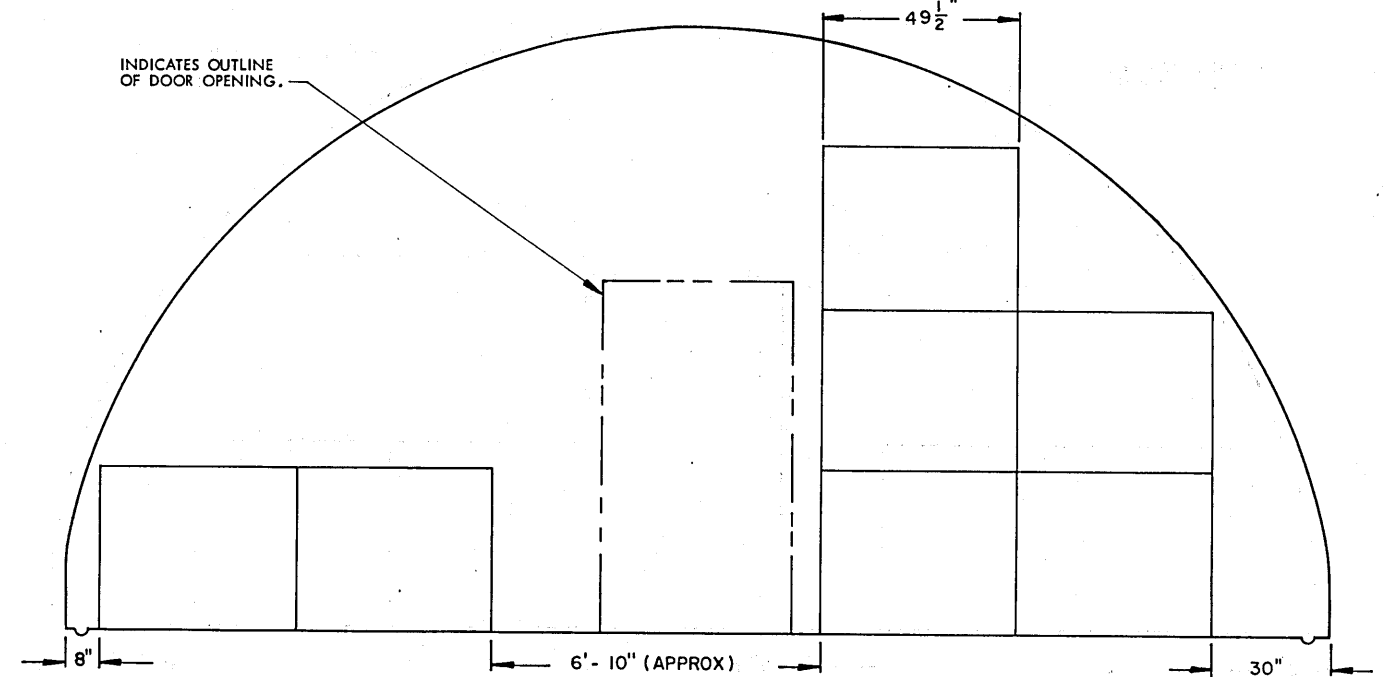

SECTION J3-J3 ("C" STACK, 7 PALLET UNITS)

STORAGE PROCEDURES FOR UNIT NO. 36 (INCREASED-HEIGHT UNIT)

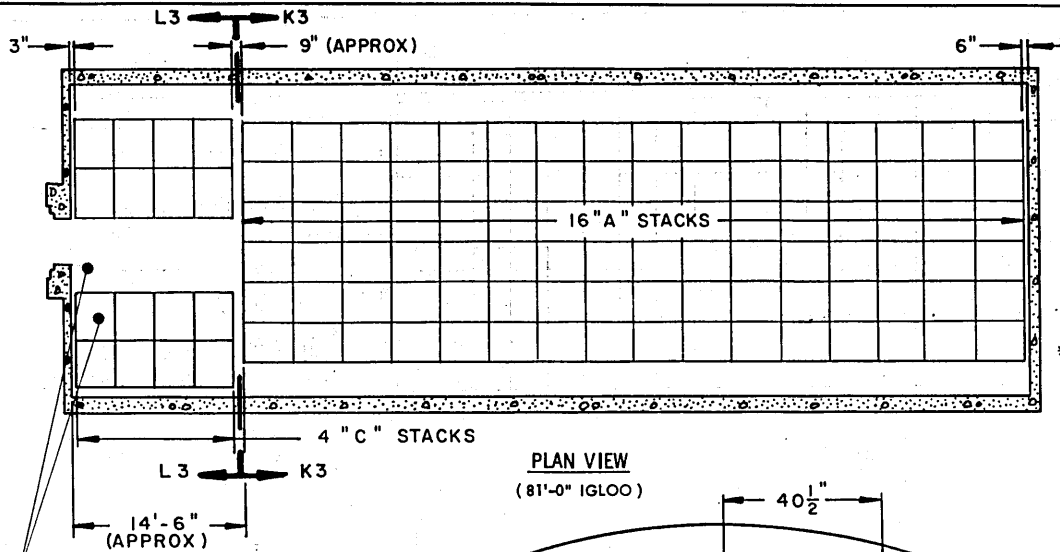

PLAN VIEW
(81'-0" IGLOO)

STORAGE IN 81'-0" IGLOO

ITEM	QUANTITY
PALLET UNITS	248

* STORAGE IN 60'-8" IGLOO

ITEM	QUANTITY
PALLET UNITS	186
* 12 A-STACKS	
3 C-STACKS	

** STORAGE IN 40'-4" IGLOO

ITEM	QUANTITY
PALLET UNITS	116
** 7 A-STACKS	
3 C-STACKS	

SEE GENERAL NOTE "G" ON PAGE 2.

SEE GENERAL NOTE "D" ON PAGE 2.

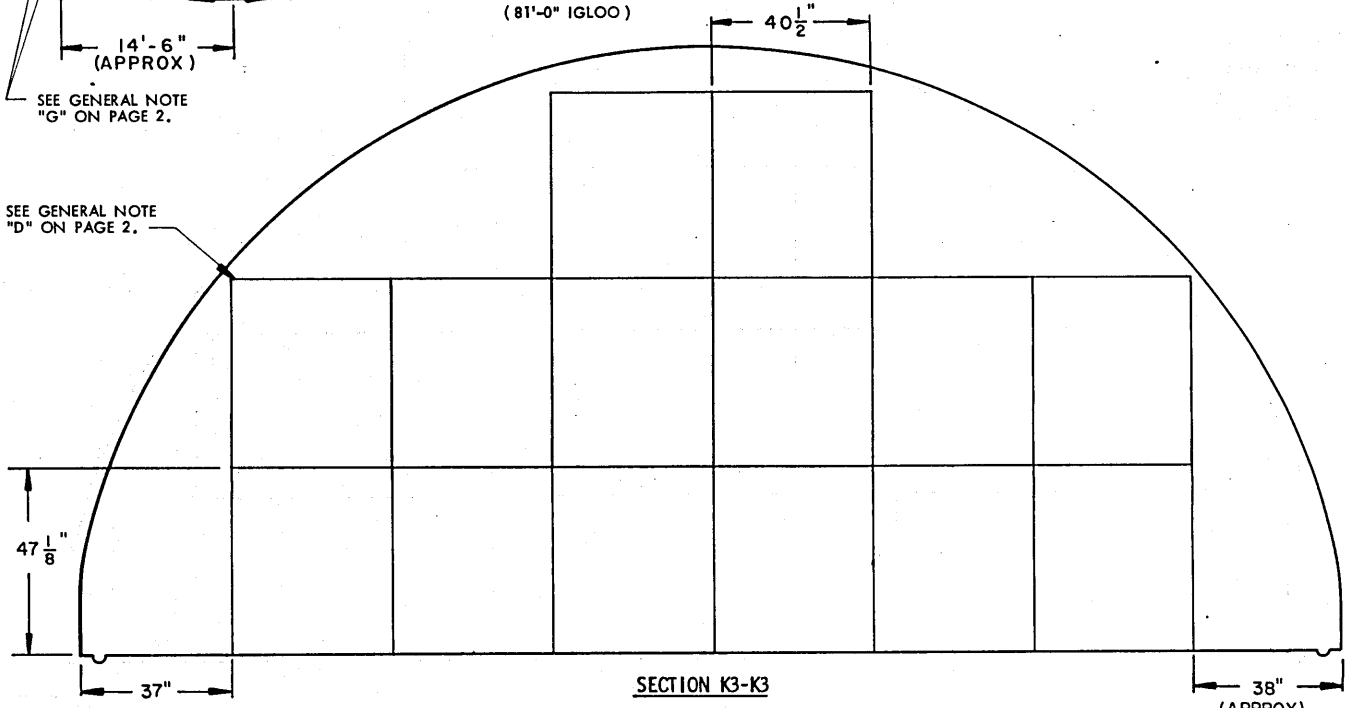

SECTION K3-K3
("A" STACK, 14 PALLET UNITS)

INDICATES OUTLINE OF DOOR OPENING.

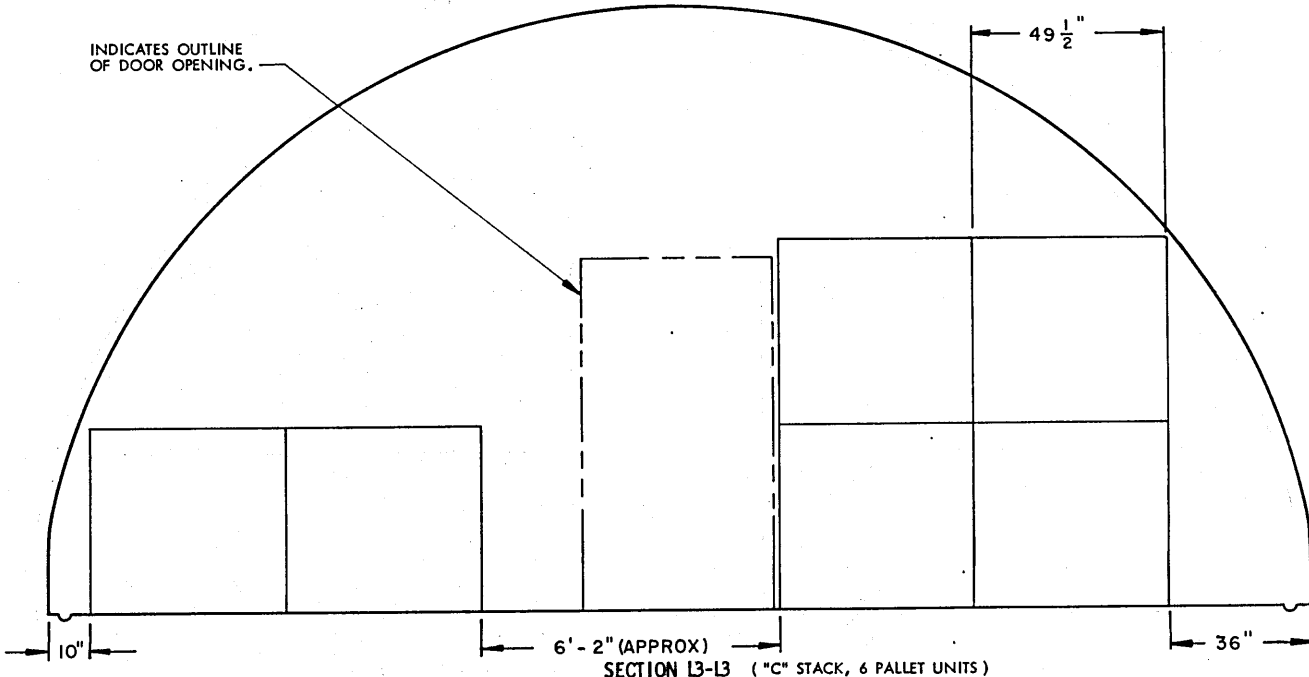

SECTION L3-L3 ("C" STACK, 6 PALLET UNITS)
STORAGE PROCEDURES FOR UNIT NO. 37

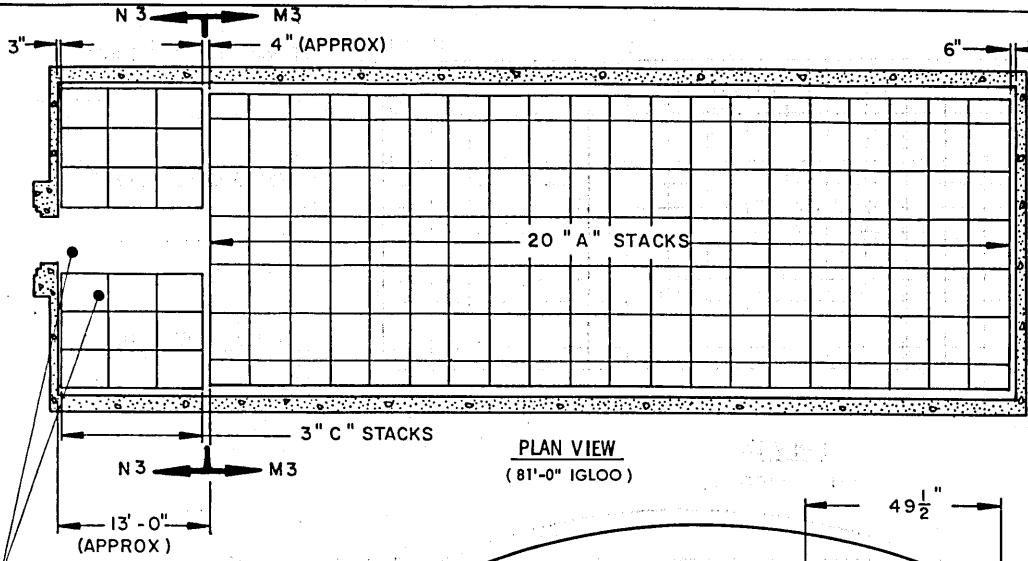

PLAN VIEW
(81'-0" IGLOO)

STORAGE IN 81'-0" IGLOO

ITEM	QUANTITY
PALLET UNITS	307

*** STORAGE IN 60'-8" IGLOO**

ITEM	QUANTITY
PALLET UNITS	223

- * 14 A-STACKS
- 3 C-STACKS

**** STORAGE IN 40'-4" IGLOO**

ITEM	QUANTITY
PALLET UNITS	139

- ** 8 A-STACKS
- 3 C-STACKS

SEE GENERAL NOTE "G" ON PAGE 2.

SEE GENERAL NOTE "D" ON PAGE 2.

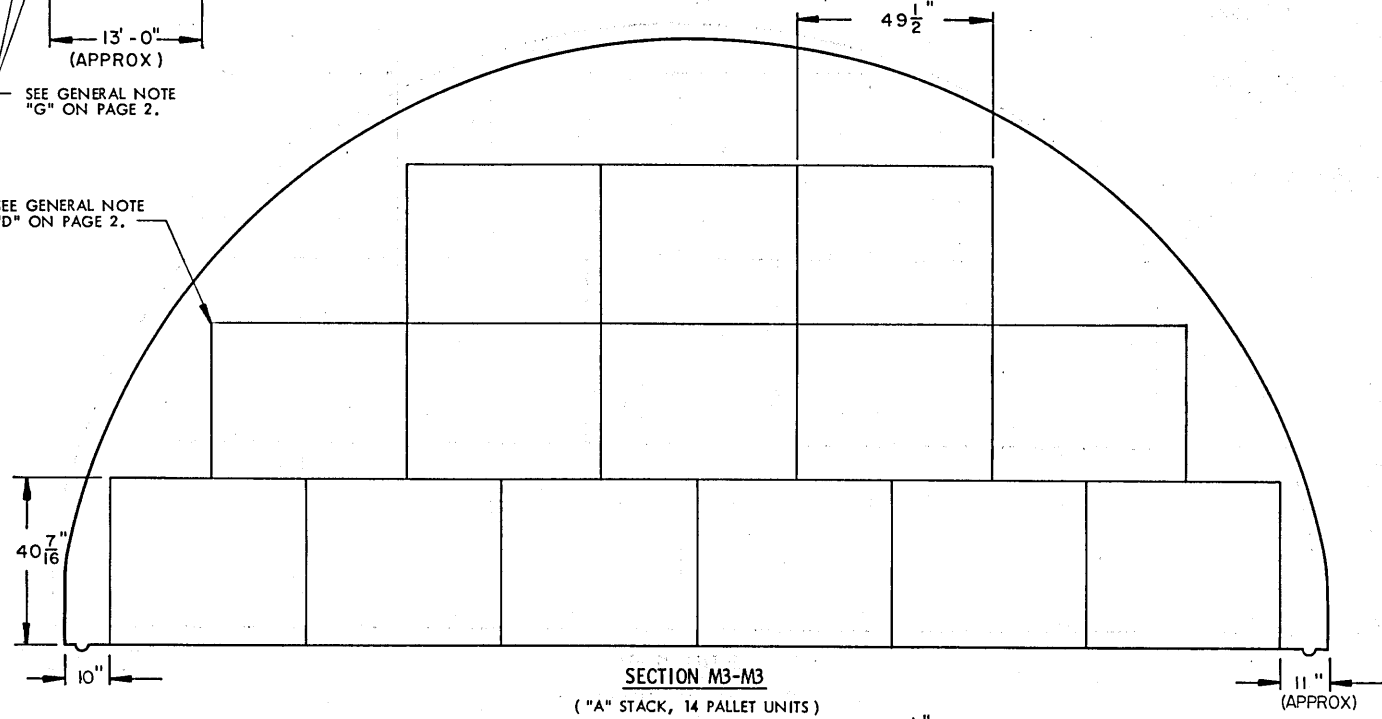

SECTION M3-M3
("A" STACK, 14 PALLET UNITS)

INDICATES OUTLINE OF DOOR OPENING.

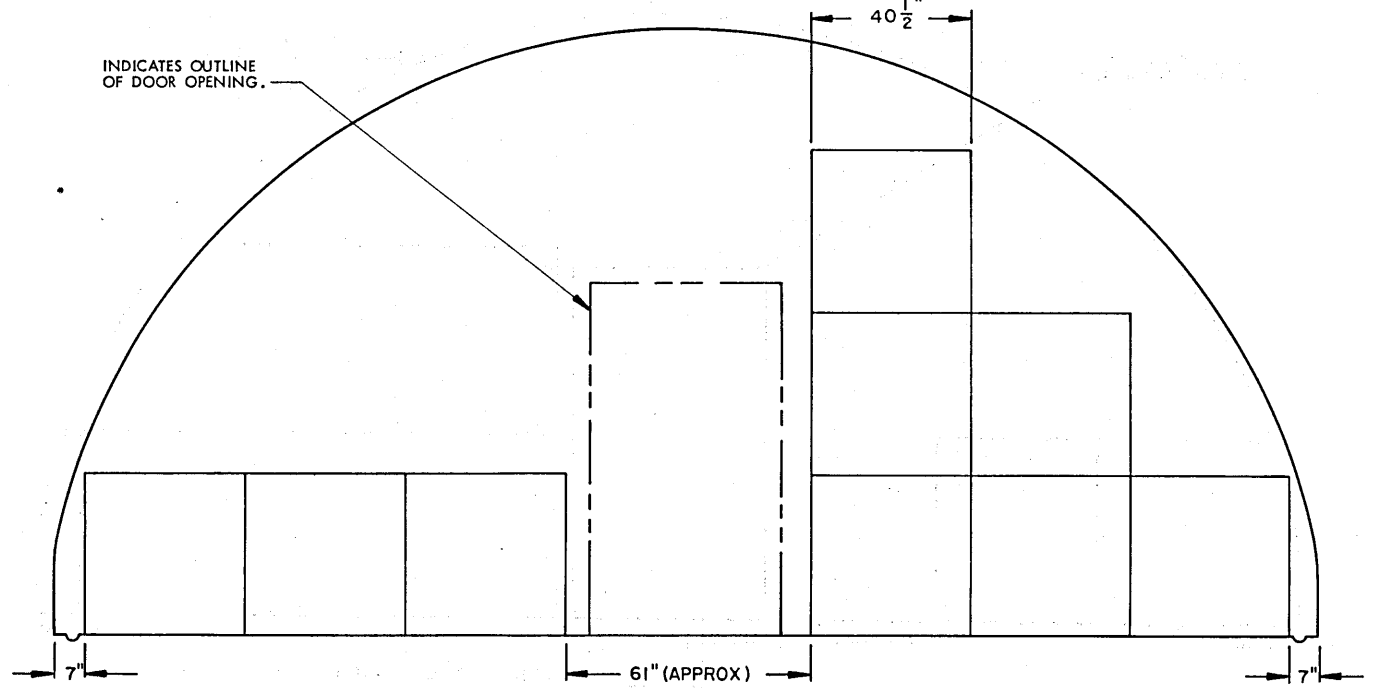

SECTION N3-N3 ("C" STACK, 9 PALLET UNITS)

STORAGE PROCEDURES FOR UNIT NO. 37 (DECREASED-HEIGHT UNIT)

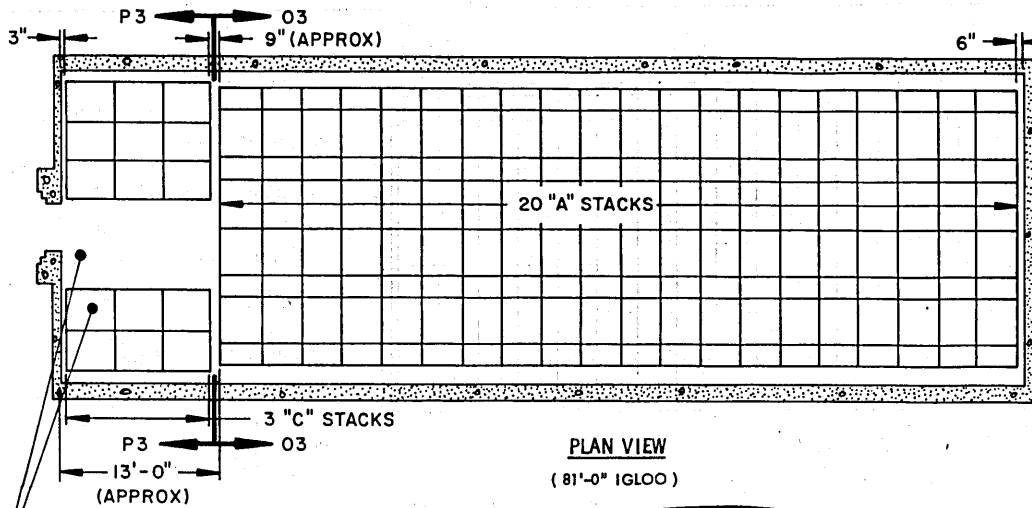

STORAGE IN 81'-0" IGLOO	
ITEM	QUANTITY
PALLET UNITS	281
* STORAGE IN 60'-8" IGLOO	
ITEM	QUANTITY
PALLET UNITS	203
14 A-STACKS	
3 C-STACKS	
* * STORAGE IN 40'-4" IGLOO	
ITEM	QUANTITY
PALLET UNITS	125
8 A-STACKS	
3 C-STACKS	

PLAN VIEW
(81'-0" IGLOO)

SEE GENERAL NOTE "G" ON PAGE 2.

SEE GENERAL NOTE "D" ON PAGE 2.

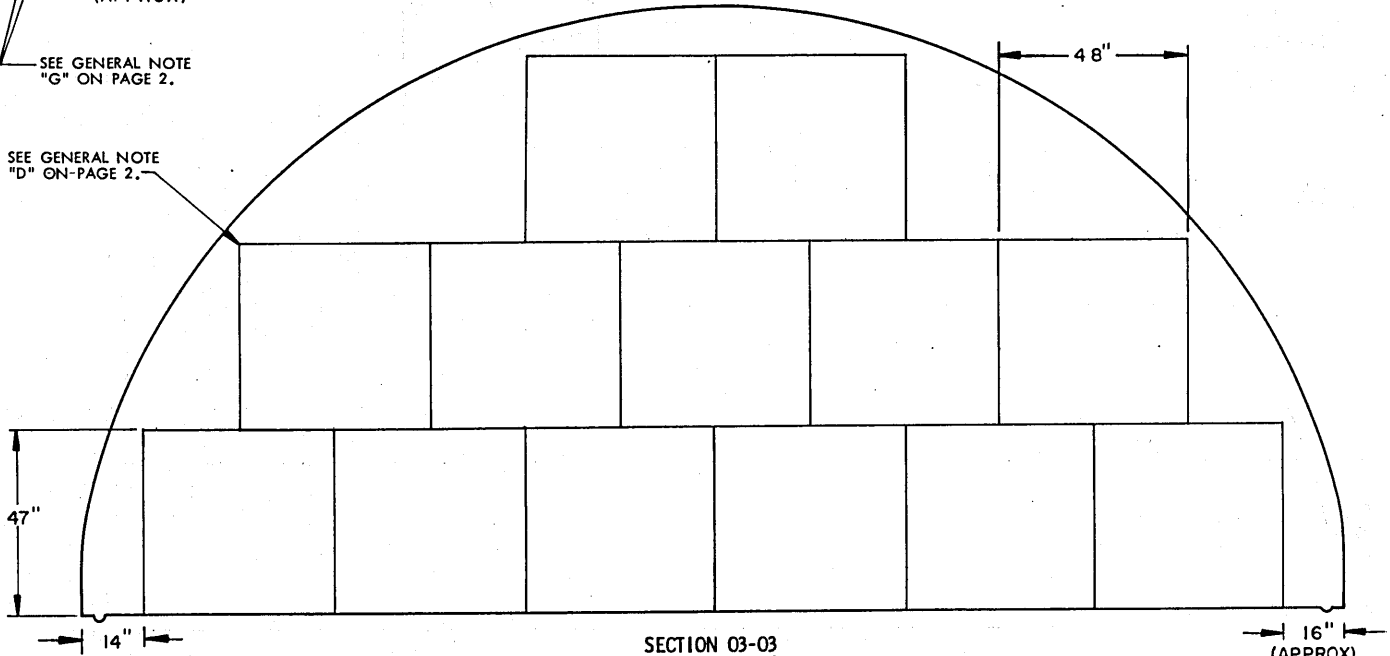

SECTION 03-03
("A" STACK, 13 PALLET UNITS)

INDICATES OUTLINE OF DOOR OPENING.

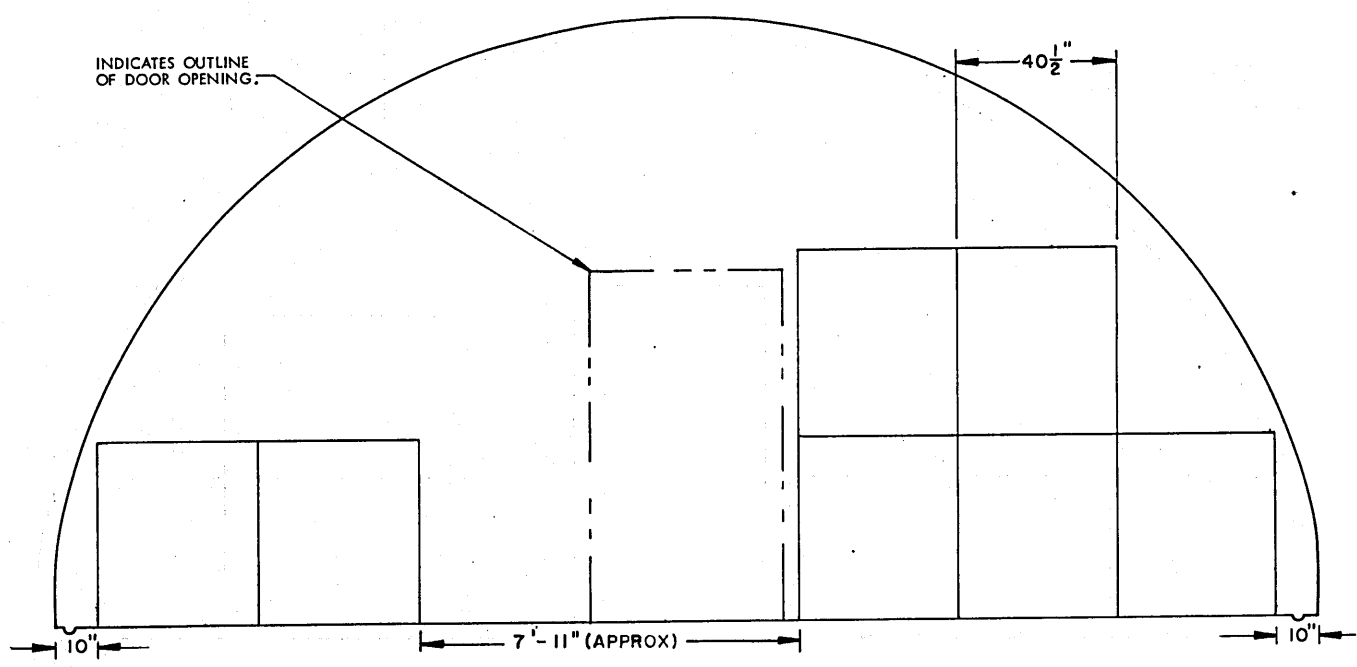

SECTION P3-P3 ("C" STACK, 7 PALLET UNITS)

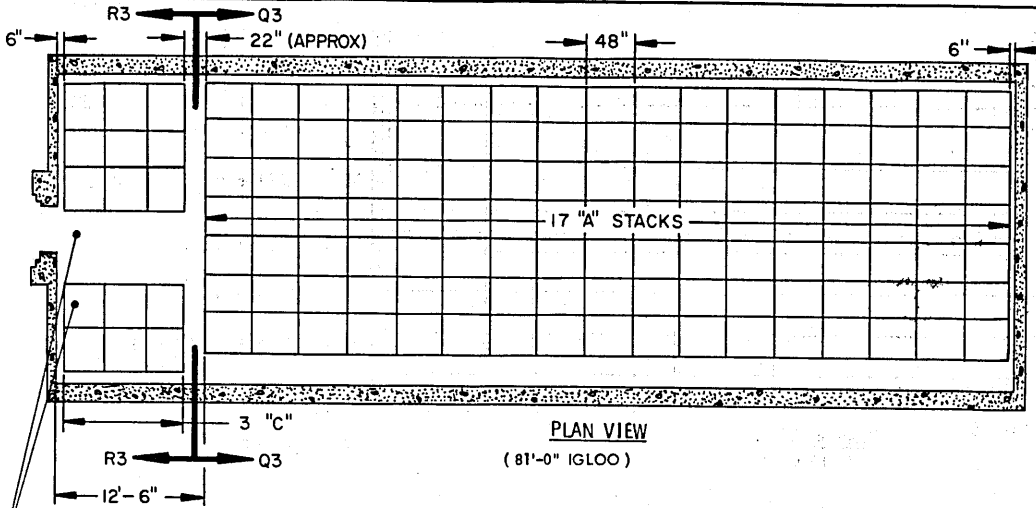

STORAGE IN 81'-0" IGLOO	
ITEM	QUANTITY
PALLET UNITS-----	313
* STORAGE IN 60'-8" IGLOO	
ITEM	QUANTITY
PALLET UNITS-----	228
* 12 A-STACKS	
3 C-STACKS	
** STORAGE IN 40'-4" IGLOO	
ITEM	QUANTITY
PALLET UNITS-----	143
** 7 A-STACKS	
3 C-STACKS	

SEE GENERAL NOTE "G" ON PAGE 2.

SEE GENERAL NOTE "D" ON PAGE 2.

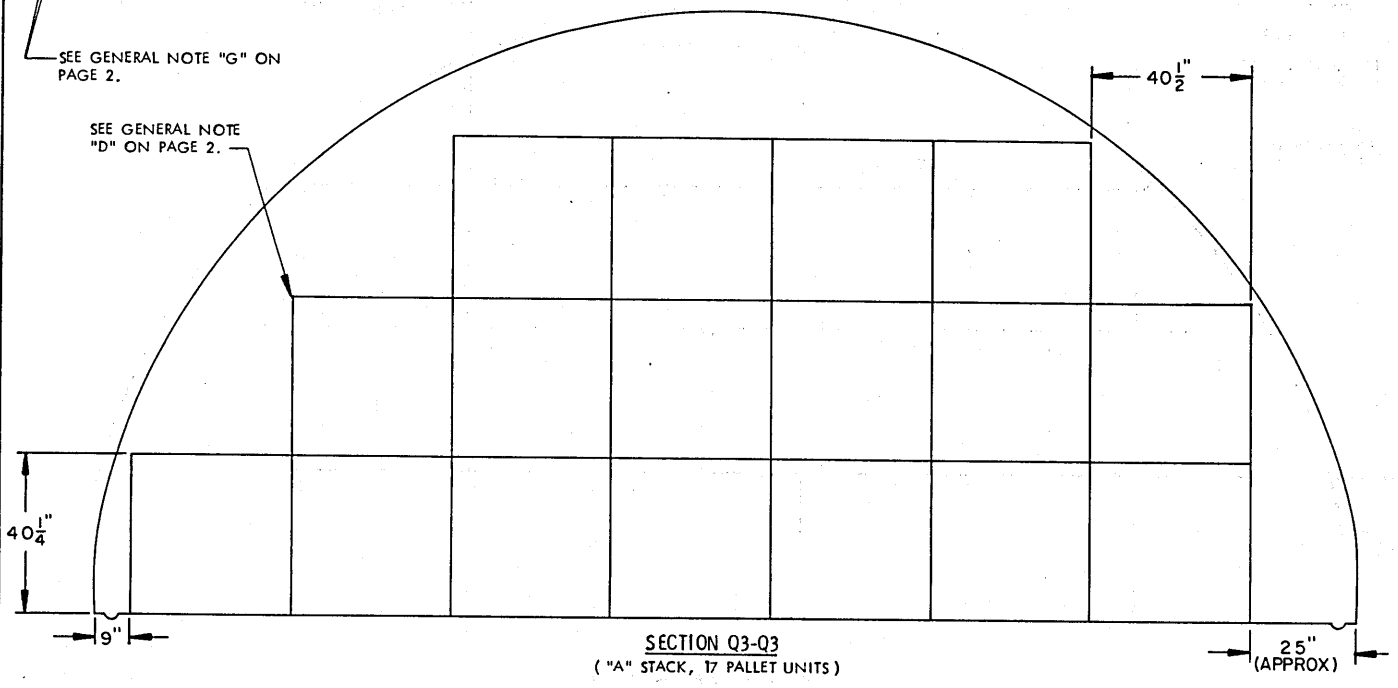

INDICATES OUTLINE OF DOOR OPENING.

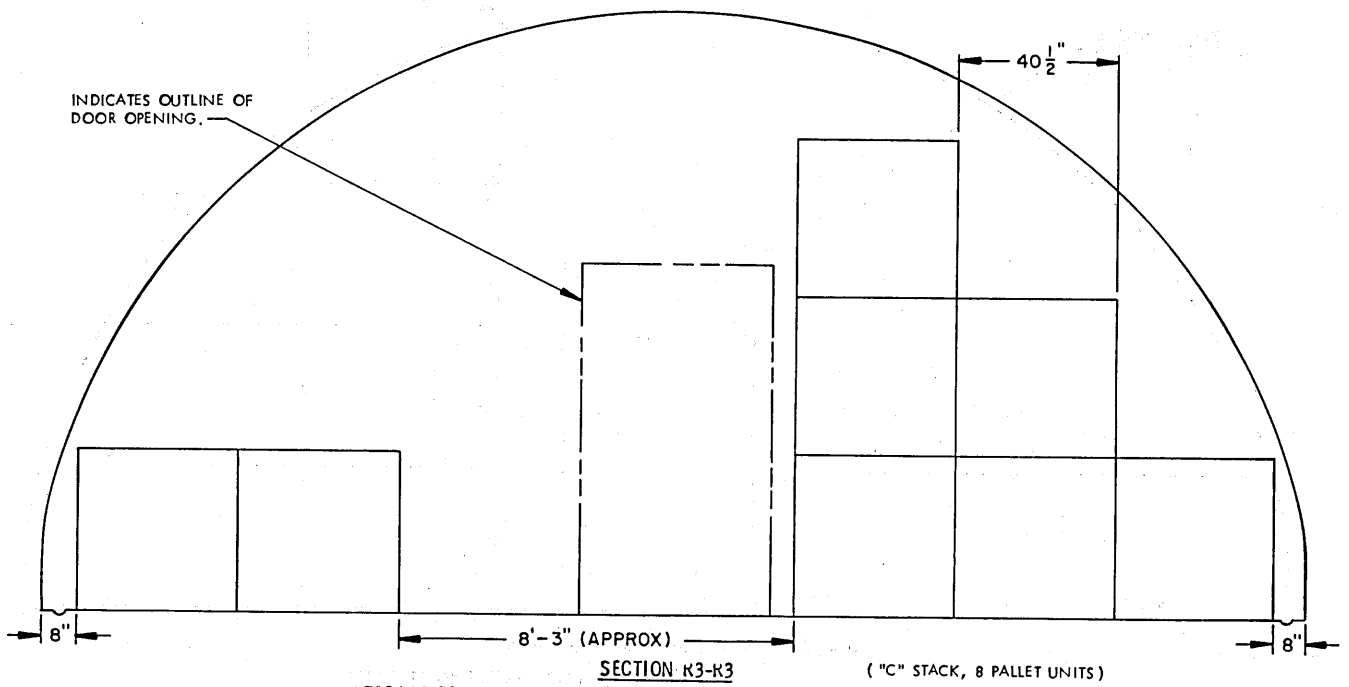

STORAGE PROCEDURES FOR UNIT NO. 38 (DECREASED-HEIGHT UNIT)

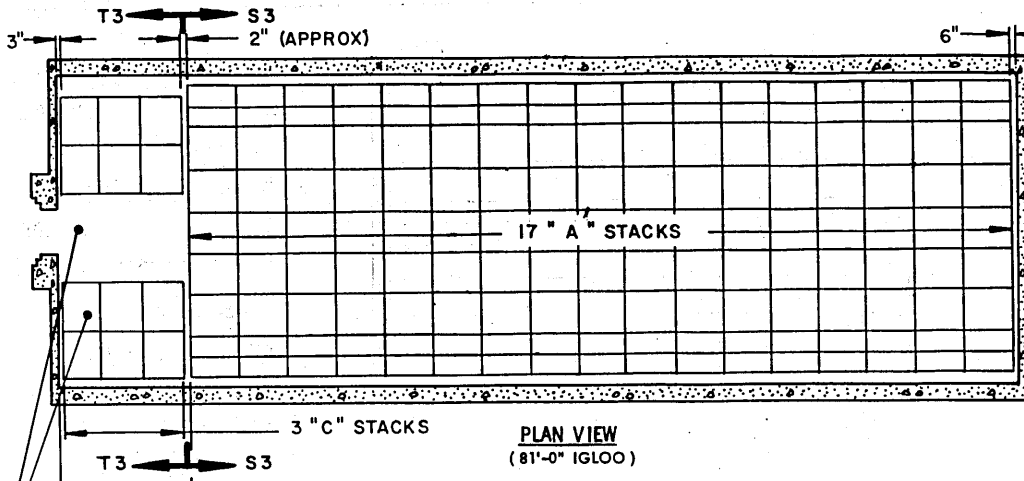

STORAGE IN 81'-0" IGLOO	
ITEM	QUANTITY
PALLET UNITS	344
* STORAGE IN 60'-8" IGLOO	
ITEM	QUANTITY
PALLET UNITS	249
* 12 A-STACKS 3 C-STACKS	
* * STORAGE IN 40'-4" IGLOO	
ITEM	QUANTITY
PALLET UNITS	154
* * 7 A-STACKS 3 C-STACKS	

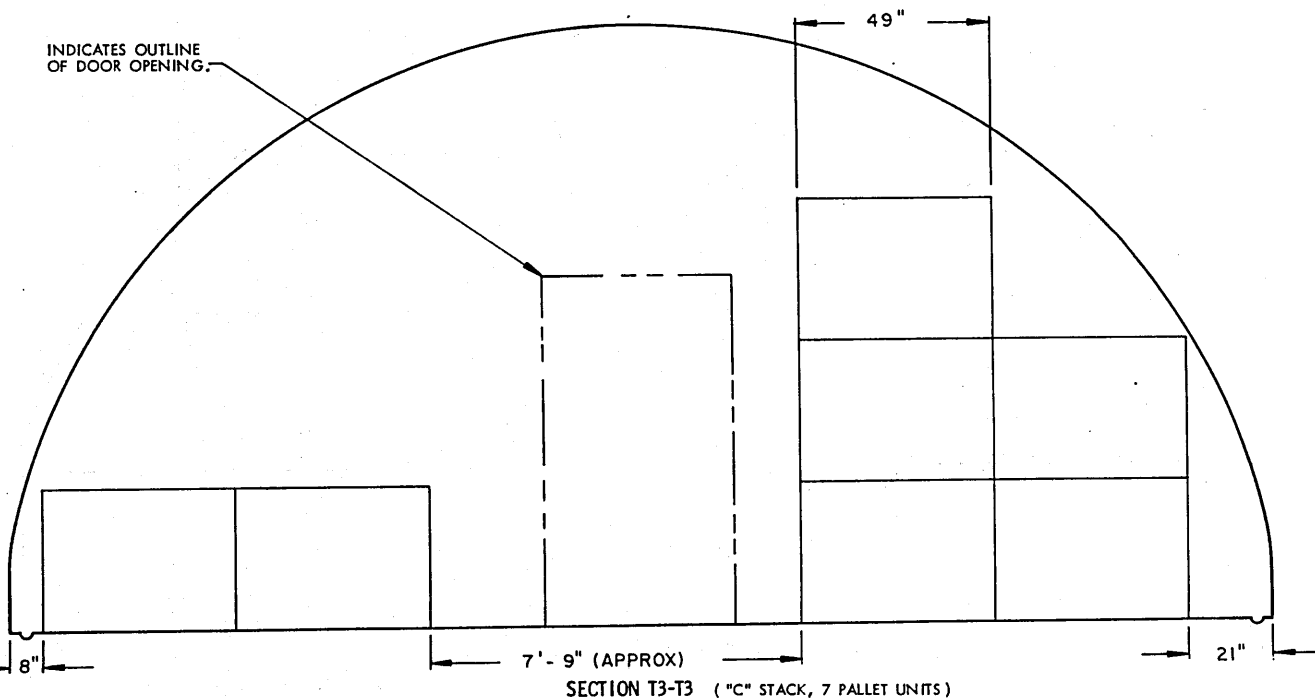
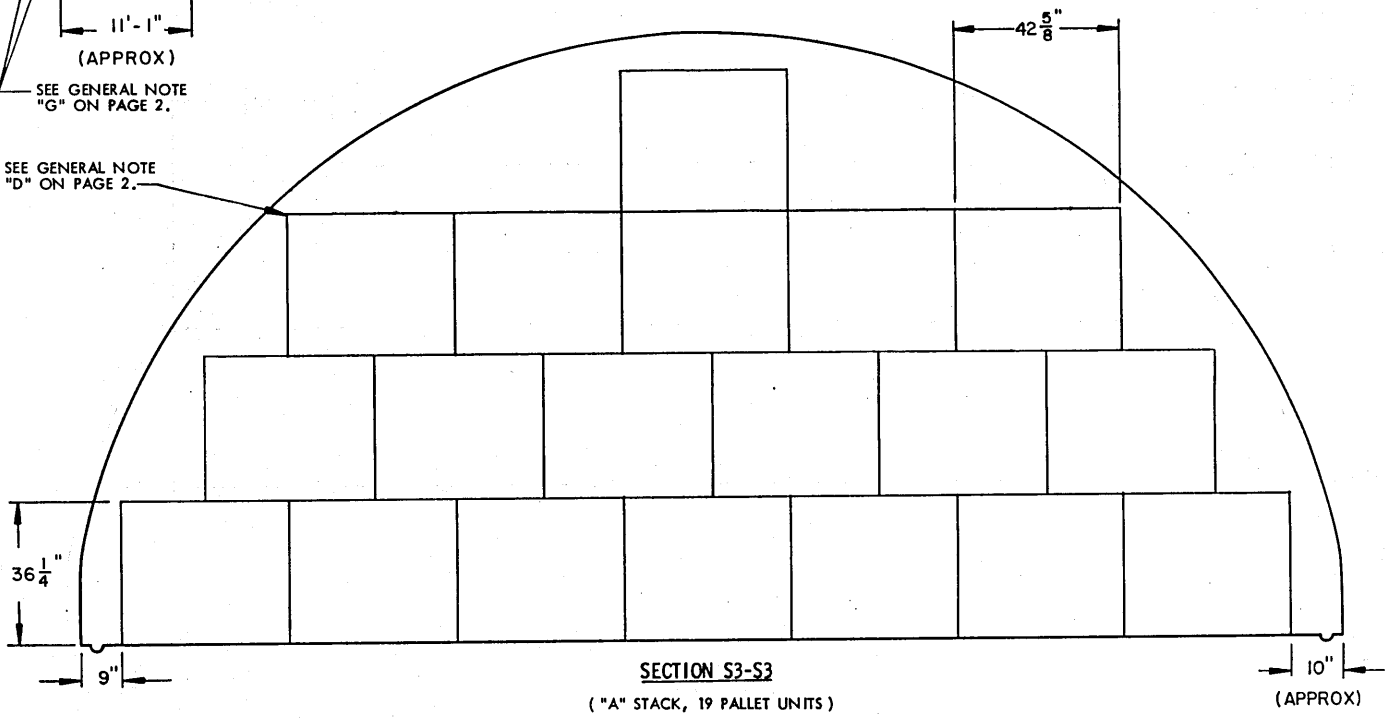

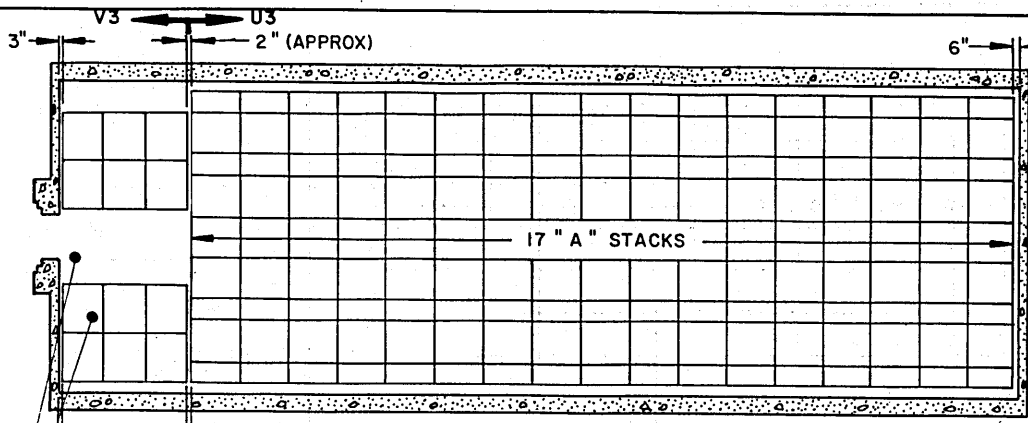

STORAGE IN 81'-0" IGLOO

ITEM	QUANTITY
PALLET UNITS	293

*** STORAGE IN 60'-8" IGLOO**

ITEM	QUANTITY
PALLET UNITS	213
* 12 A-STACKS	
3 C-STACKS	

**** STORAGE IN 40'-4" IGLOO**

ITEM	QUANTITY
PALLET UNITS	133
** 7 A-STACKS	
3 C-STACKS	

PLAN VIEW
(81'-0" IGLOO)

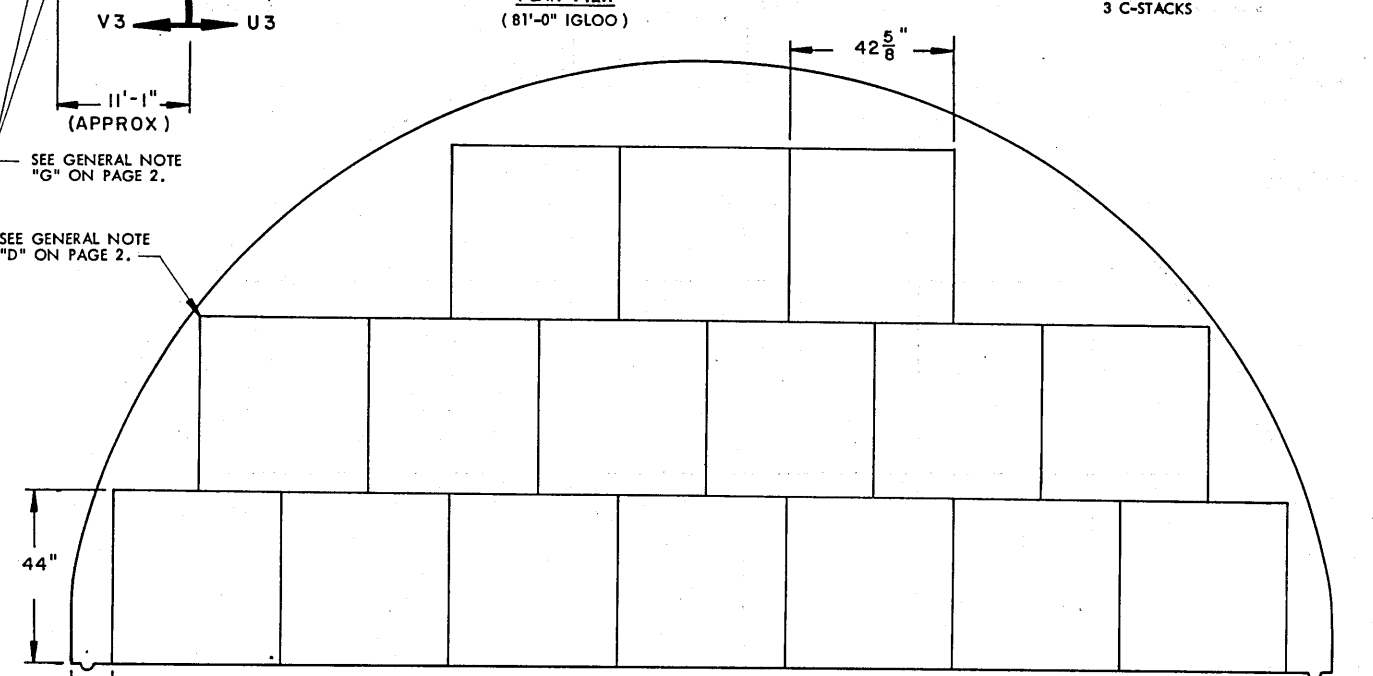

SECTION U3-U3
("A" STACK, 16 PALLET UNITS)

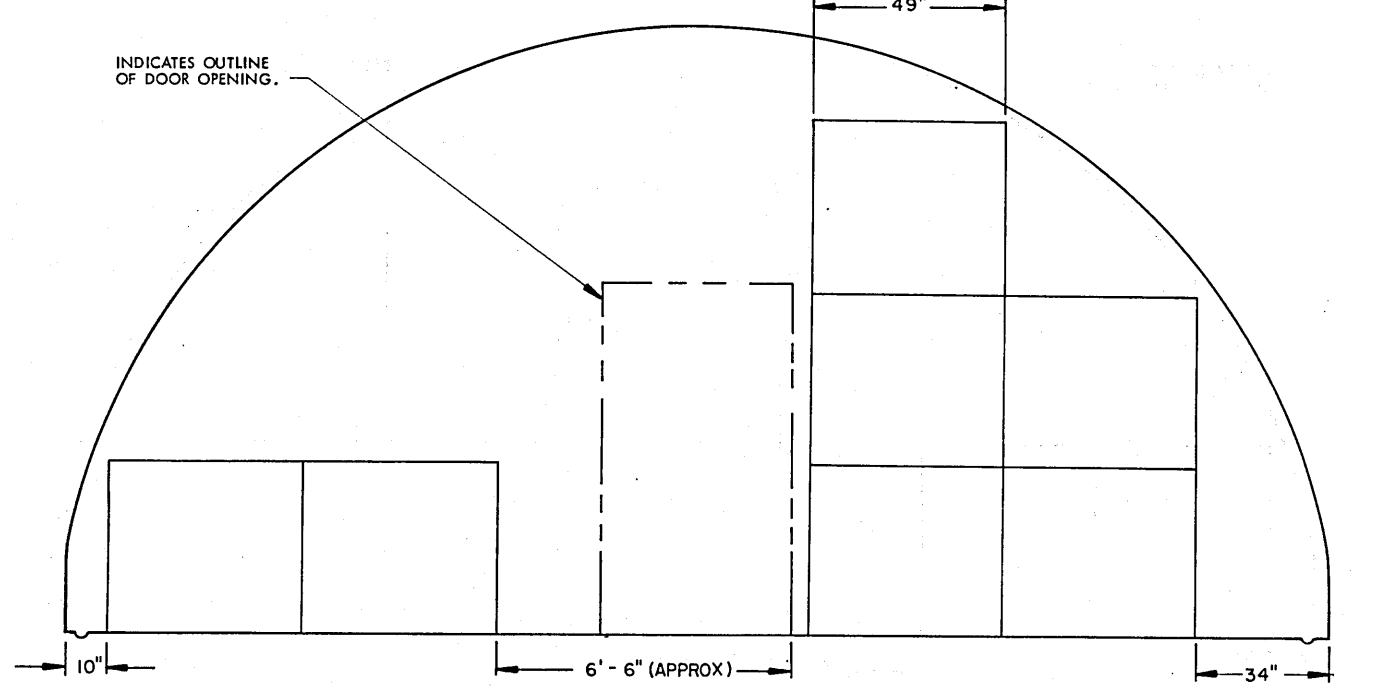

SECTION V3-V3 ("C" STACK, 7 PALLET UNITS)

STORAGE PROCEDURES FOR UNIT NO. 39 (INCREASED-HEIGHT UNIT)

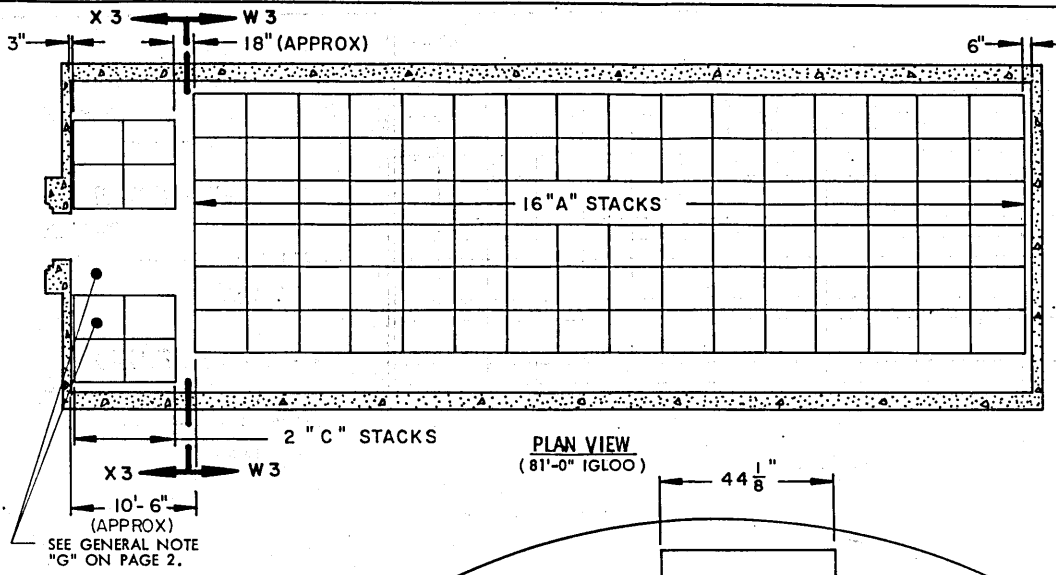

STORAGE IN 81'-0" IGLOO	
ITEM	QUANTITY
PALLET UNITS	204
* STORAGE IN 60'-8" IGLOO	
ITEM	QUANTITY
PALLET UNITS	144
* 11 A-STACKS	
2 C-STACKS	
** STORAGE IN 40'-4" IGLOO	
ITEM	QUANTITY
PALLET UNITS	90
** 6 A-STACKS	
3 C-STACKS	

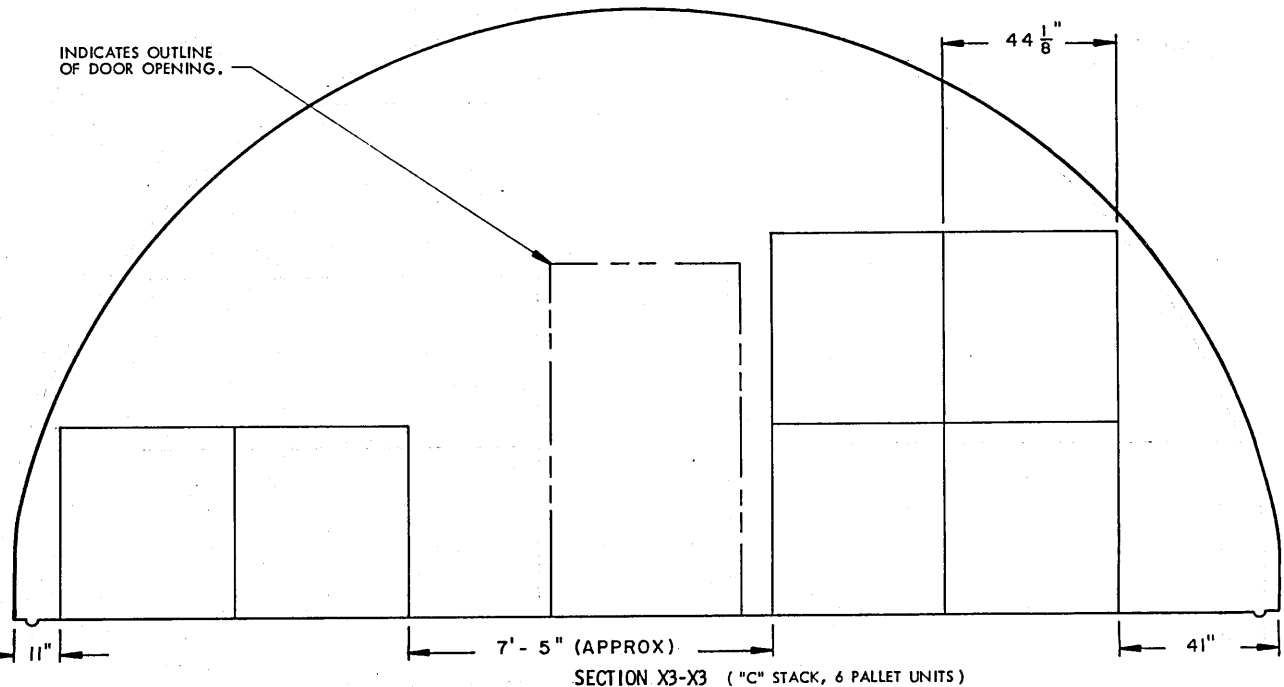
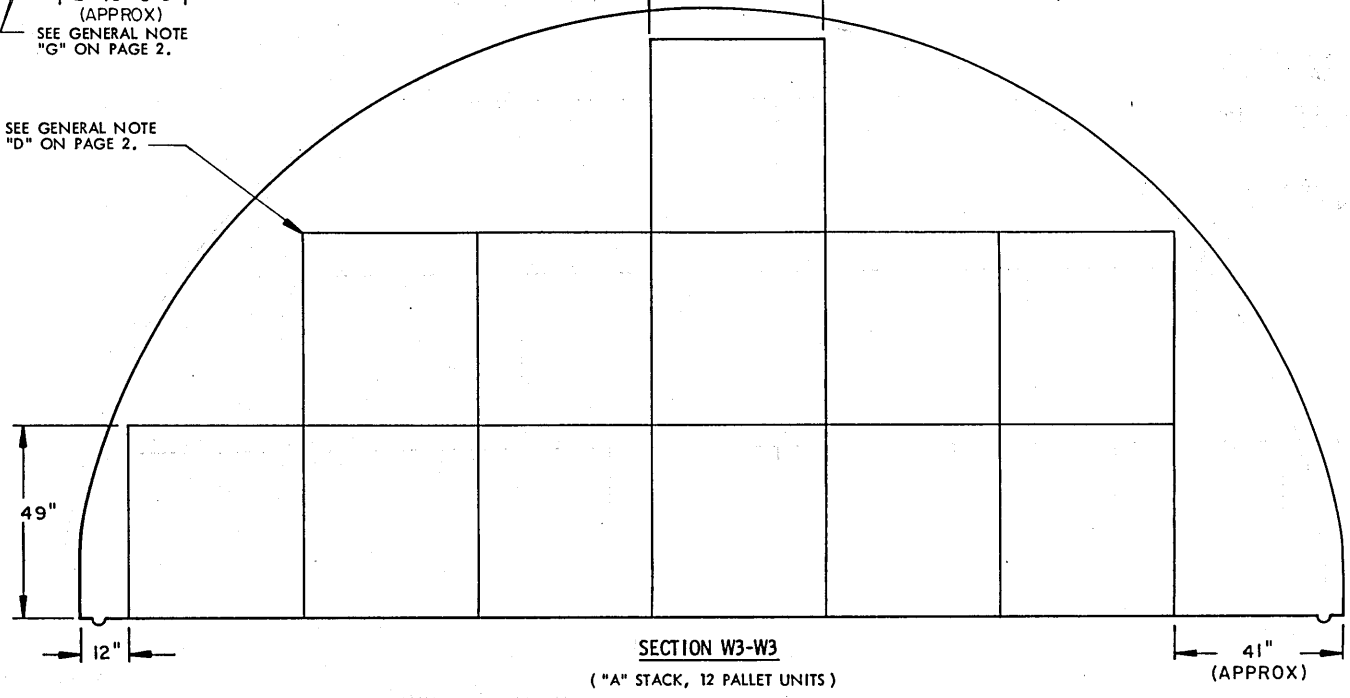

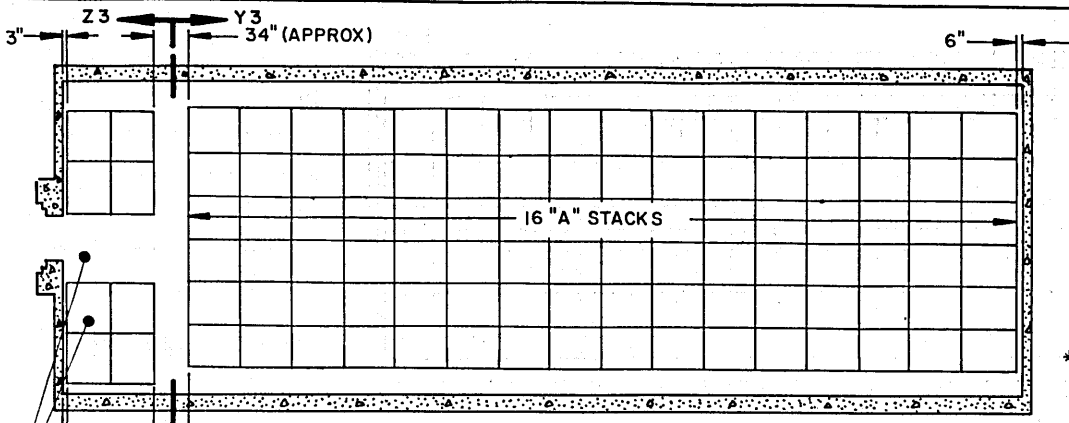

STORAGE IN 81'-0" IGLOO

ITEM	QUANTITY
PALLET UNITS	270

*** STORAGE IN 60'-8" IGLOO**

ITEM	QUANTITY
PALLET UNITS	190
* 11 A-STACKS	
2 C-STACKS	

**** STORAGE IN 40'-4" IGLOO**

ITEM	QUANTITY
PALLET UNITS	117
** 6 A-STACKS	
3 C-STACKS	

PLAN VIEW
(81'-0" IGLOO)

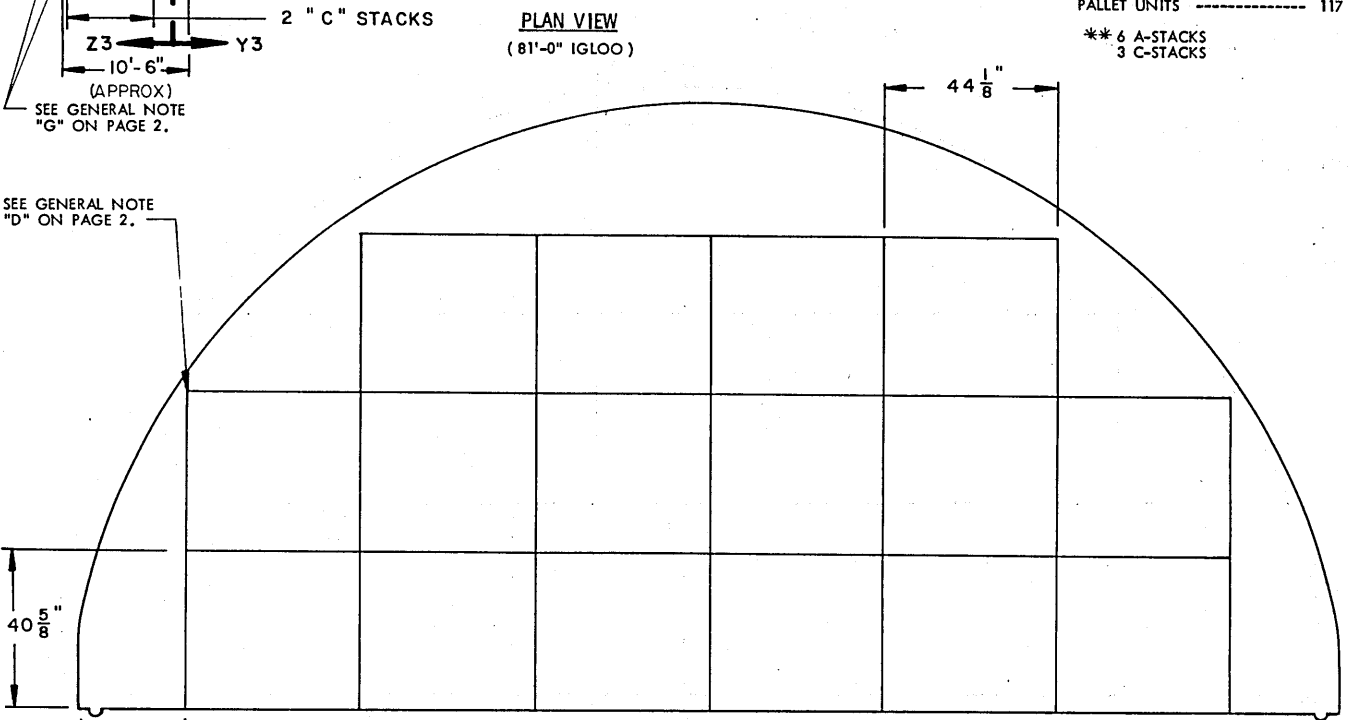

SECTION Y3-Y3
("A" STACK, 16 PALLET UNITS)

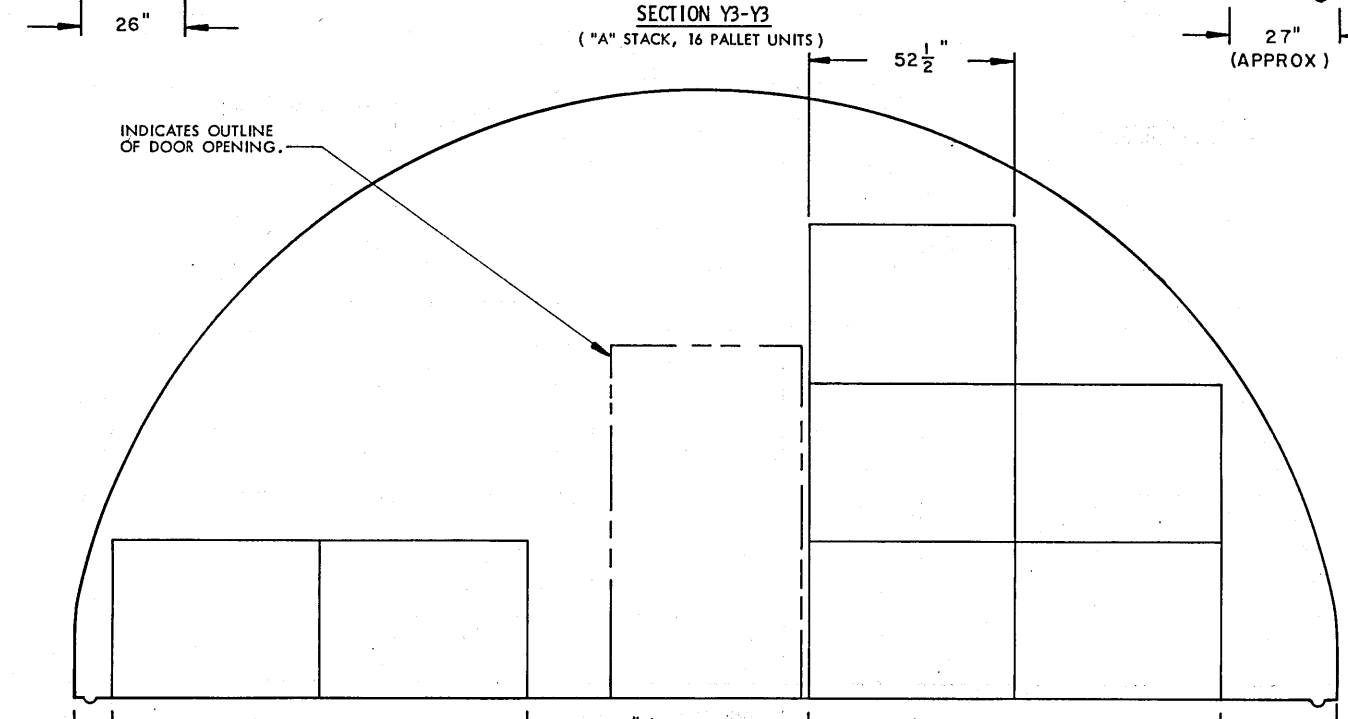

SECTION Z3-Z3 ("C" STACK, 7 PALLET UNITS)

INDICATES OUTLINE OF DOOR OPENING.

STORAGE PROCEDURES FOR UNIT NO. 40 (DECREASED-HEIGHT UNIT)

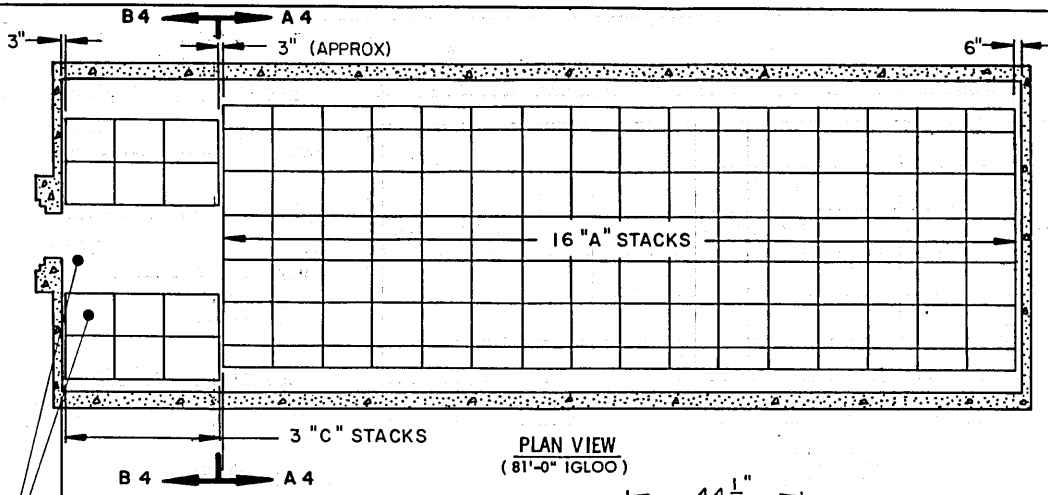

STORAGE IN 81'-0" IGLOO

ITEM	QUANTITY
PALLET UNITS	210

*** STORAGE IN 60'-8" IGLOO**

ITEM	QUANTITY
PALLET UNITS	144
* 11 A-STACKS	
2 C-STACKS	

**** STORAGE IN 40'-4" IGLOO**

ITEM	QUANTITY
PALLET UNITS	90
** 6 A-STACKS	
3 C-STACKS	

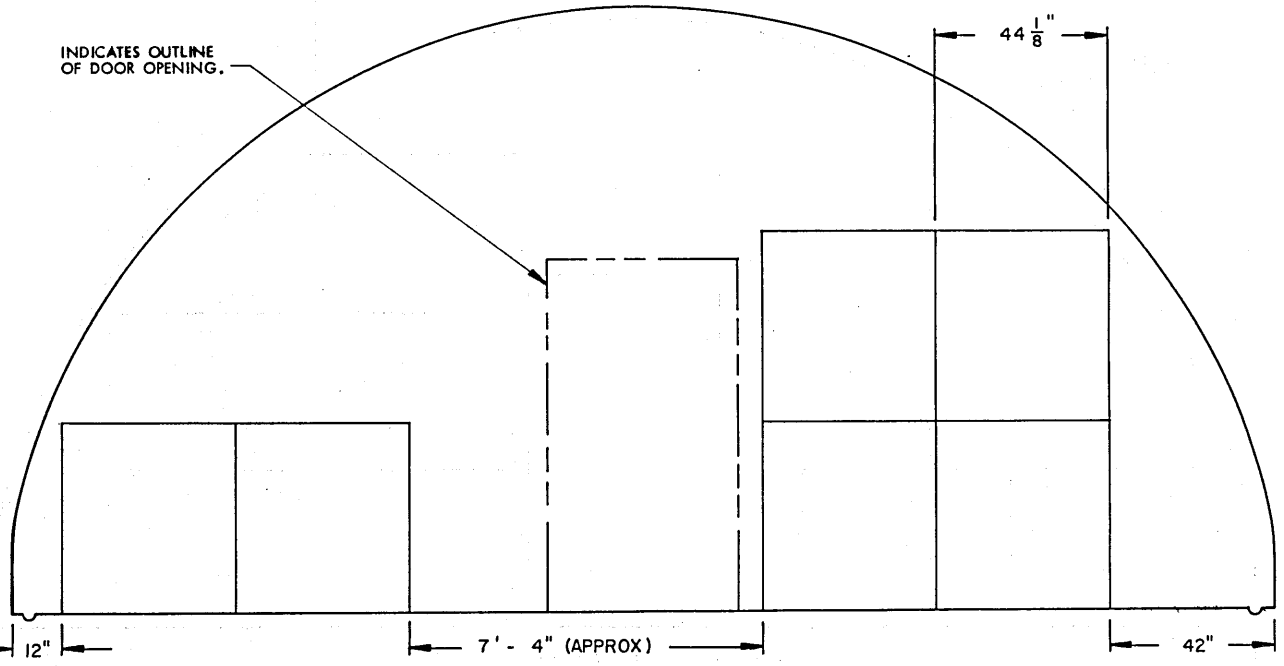
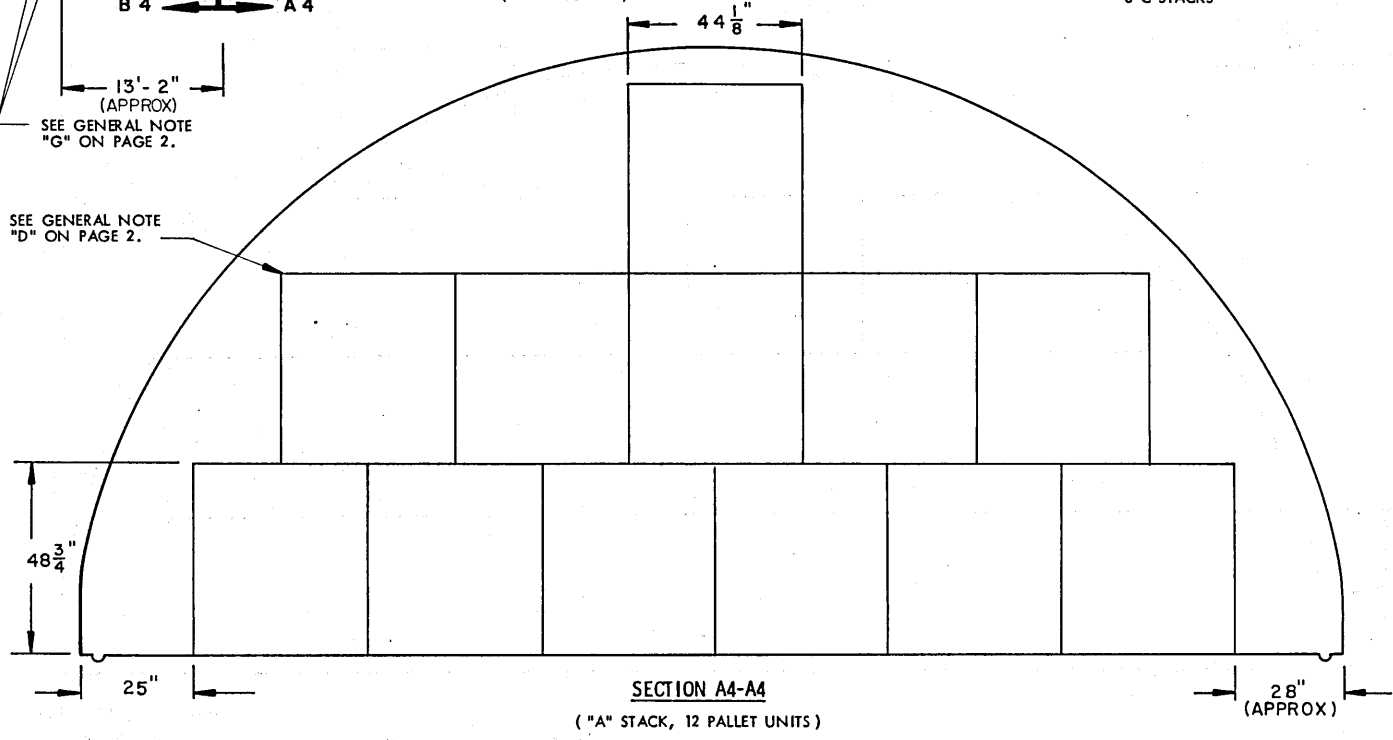

SECTION B4-B4 ("C" STACK, 6 PALLET UNITS)
STORAGE PROCEDURES FOR UNIT NO. 41

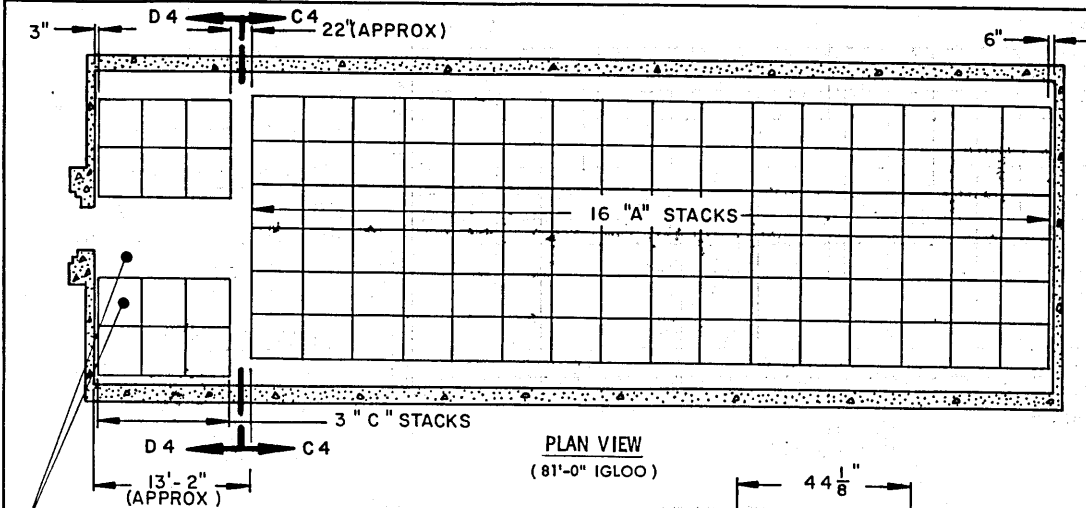

STORAGE IN 81'-0" IGLOO

ITEM	QUANTITY
PALLET UNITS	277

*** STORAGE IN 60'-8" IGLOO**

ITEM	QUANTITY
PALLET UNITS	197
* 11 A-STACKS	
3 C-STACKS	

**** STORAGE IN 40'-4" IGLOO**

ITEM	QUANTITY
PALLET UNITS	117
** 6 A-STACKS	
3 C-STACKS	

PLAN VIEW
(81'-0" IGLOO)

SEE GENERAL NOTE "G" ON PAGE 2.

SEE GENERAL NOTE "D" ON PAGE 2.

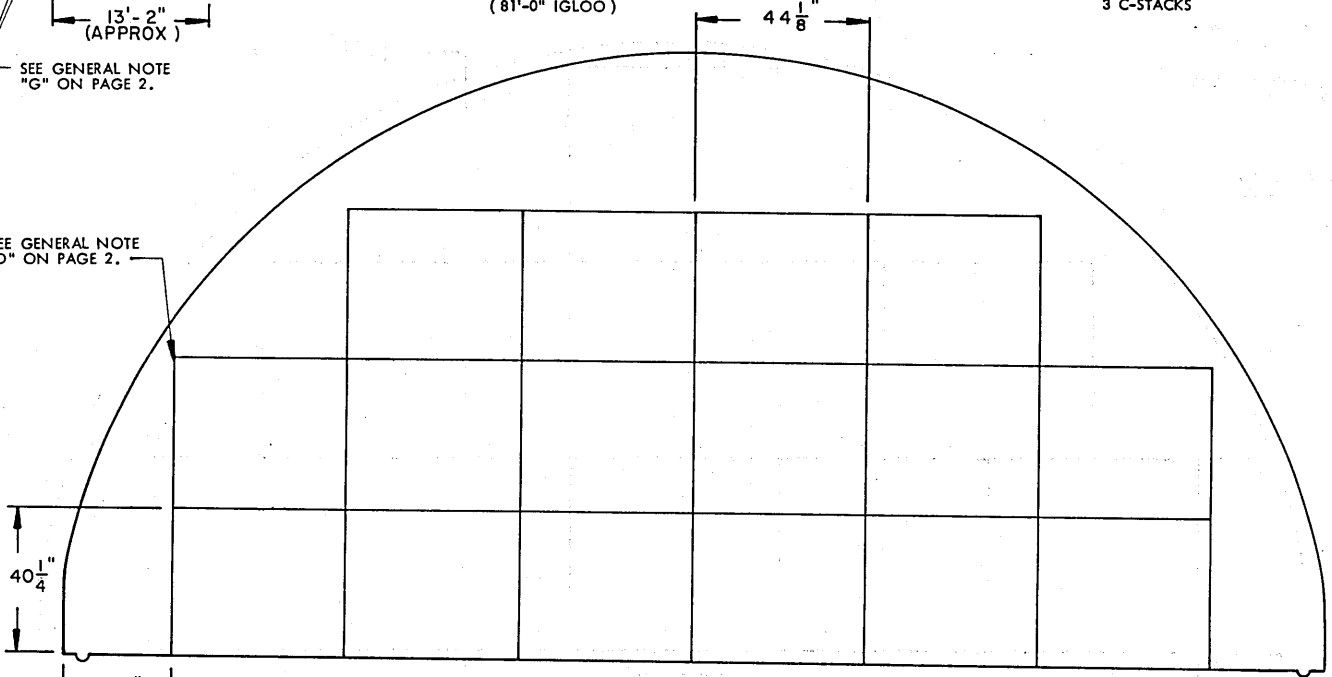

SECTION C4-C4
("A" STACK, 16 PALLET UNITS)

INDICATES OUTLINE OF DOOR OPENING.

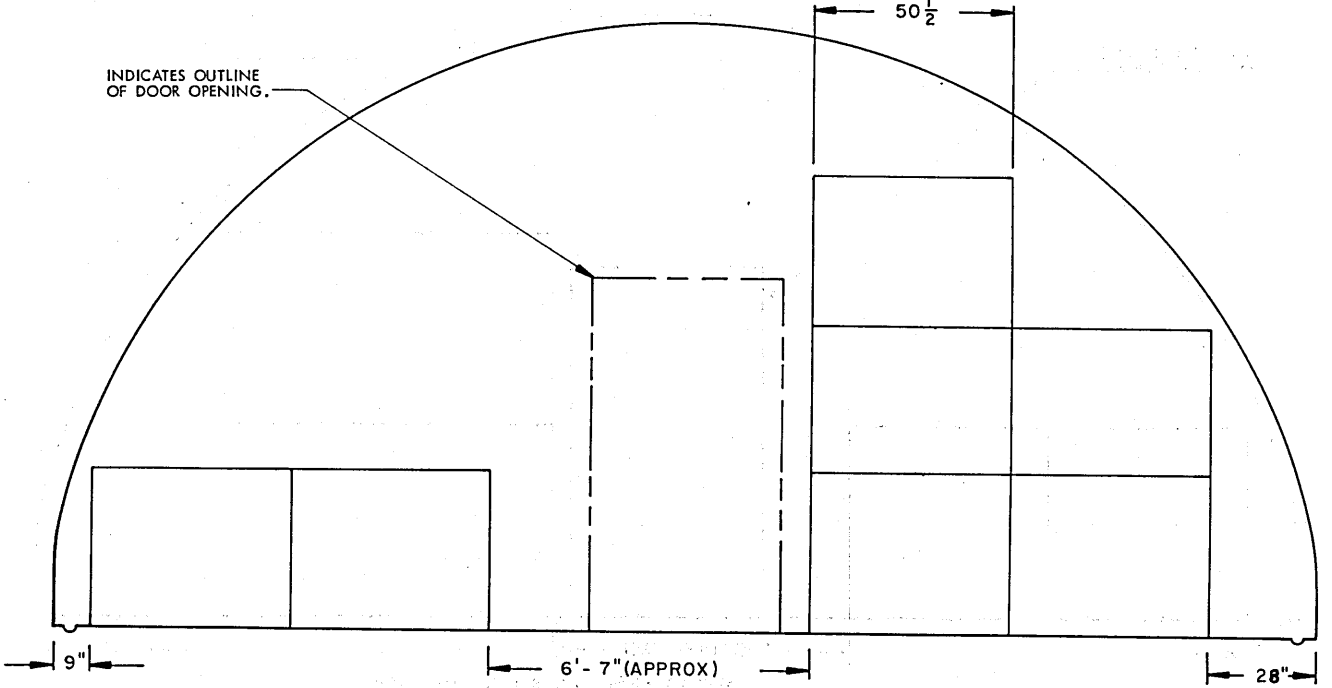

SECTION D4-D4 ("C" STACK, 7 PALLET UNITS)
STORAGE PROCEDURES FOR UNIT NO. 41 (DECREASED-HEIGHT UNIT)

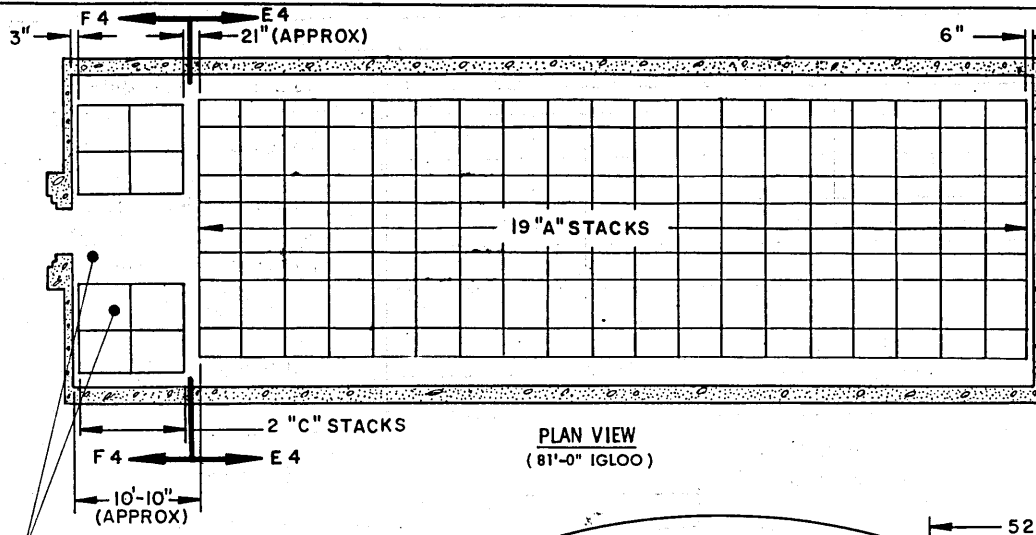

PLAN VIEW
(81'-0" IGLOO)

STORAGE IN 81'-0" IGLOO

ITEM	QUANTITY
PALLET UNITS	202

*** STORAGE IN 60'-8" IGLOO**

ITEM	QUANTITY
PALLET UNITS	142

- * 13 A-STACKS
- 2 C-STACKS

**** STORAGE IN 40'-4" IGLOO**

ITEM	QUANTITY
PALLET UNITS	92

- ** 8 A-STACKS
- 2 C-STACKS

SEE GENERAL NOTE "G" ON PAGE 2.

SEE GENERAL NOTE "D" ON PAGE 2.

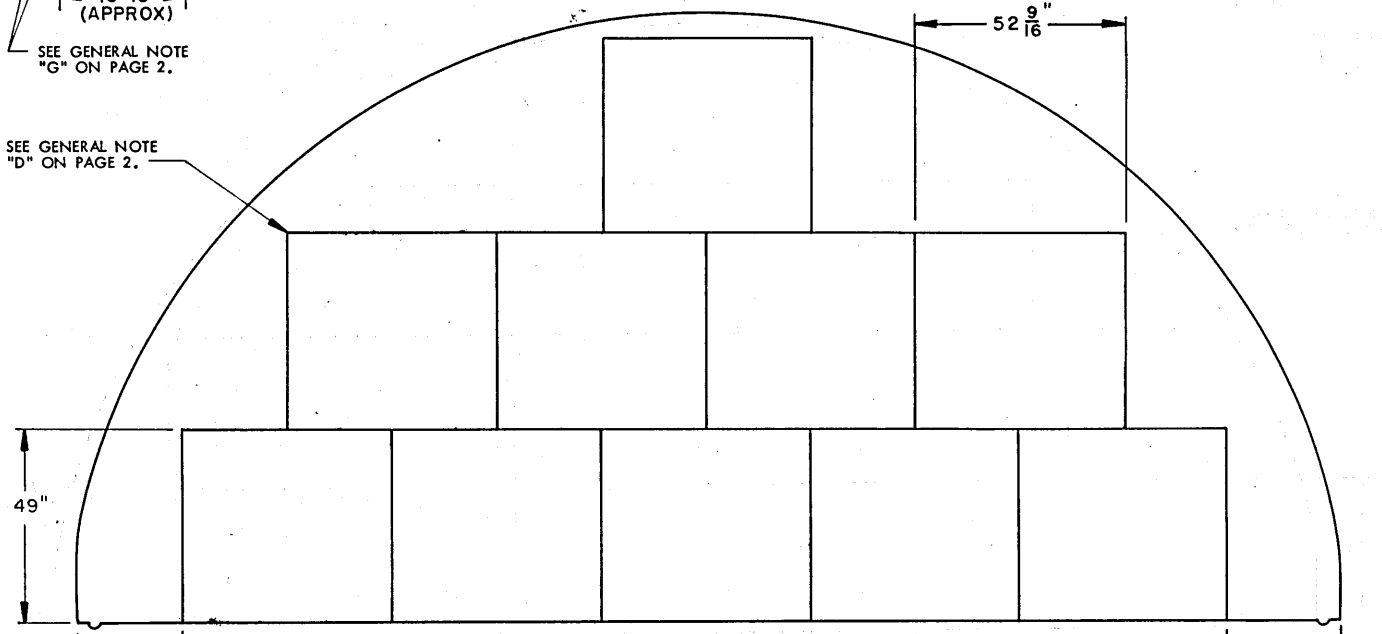

SECTION E4-E4
("A" STACK, 10 PALLET UNITS)

INDICATES OUTLINE OF DOOR OPENING.

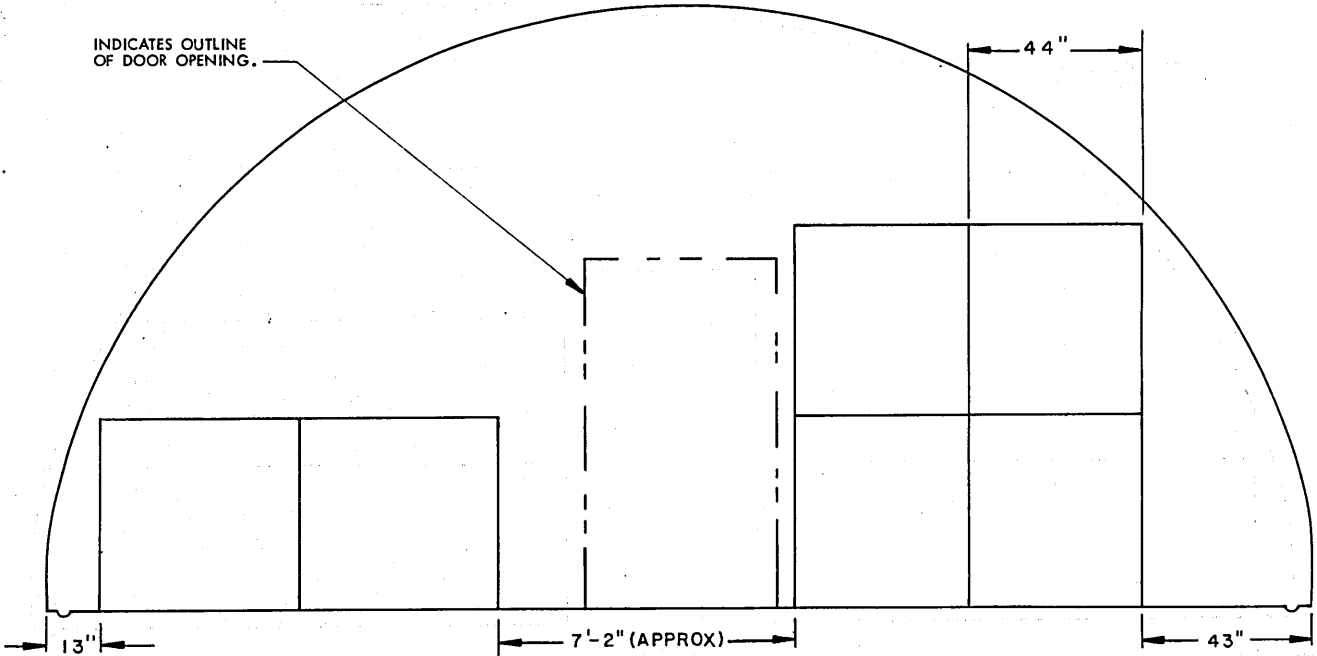

SECTION F4-F4 ("C" STACK, 6 PALLET UNITS)

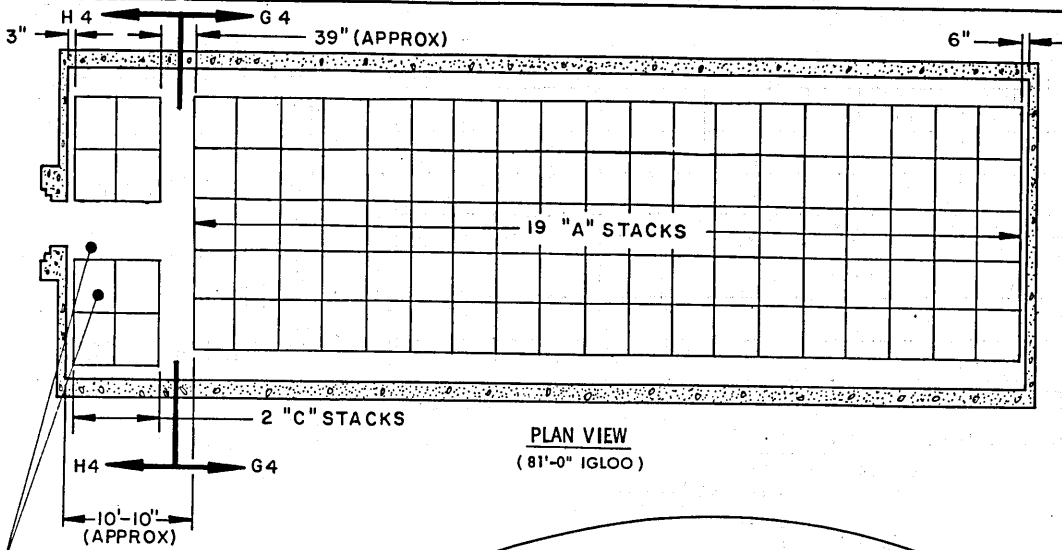

PLAN VIEW
(81'-0" IGLOO)

STORAGE IN 81'-0" IGLOO

ITEM	QUANTITY
PALLET UNITS	261

* STORAGE IN 60'-8" IGLOO

ITEM	QUANTITY
PALLET UNITS	190
* 13 A-STACKS	
3 C-STACKS	

** STORAGE IN 40'-4" IGLOO

ITEM	QUANTITY
PALLET UNITS	118
** 8 A-STACKS	
2 C-STACKS	

SEE GENERAL NOTE "G" ON PAGE 2.

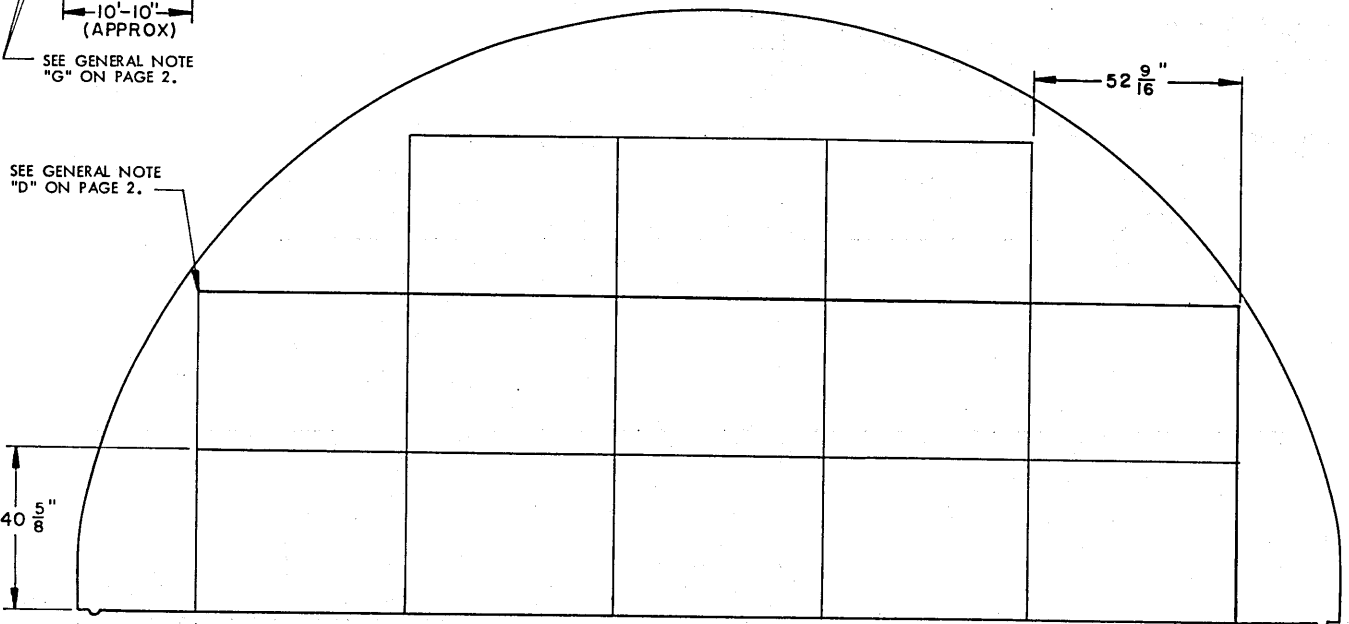

SECTION G4-G4
("A" STACK, 13 PALLET UNITS)

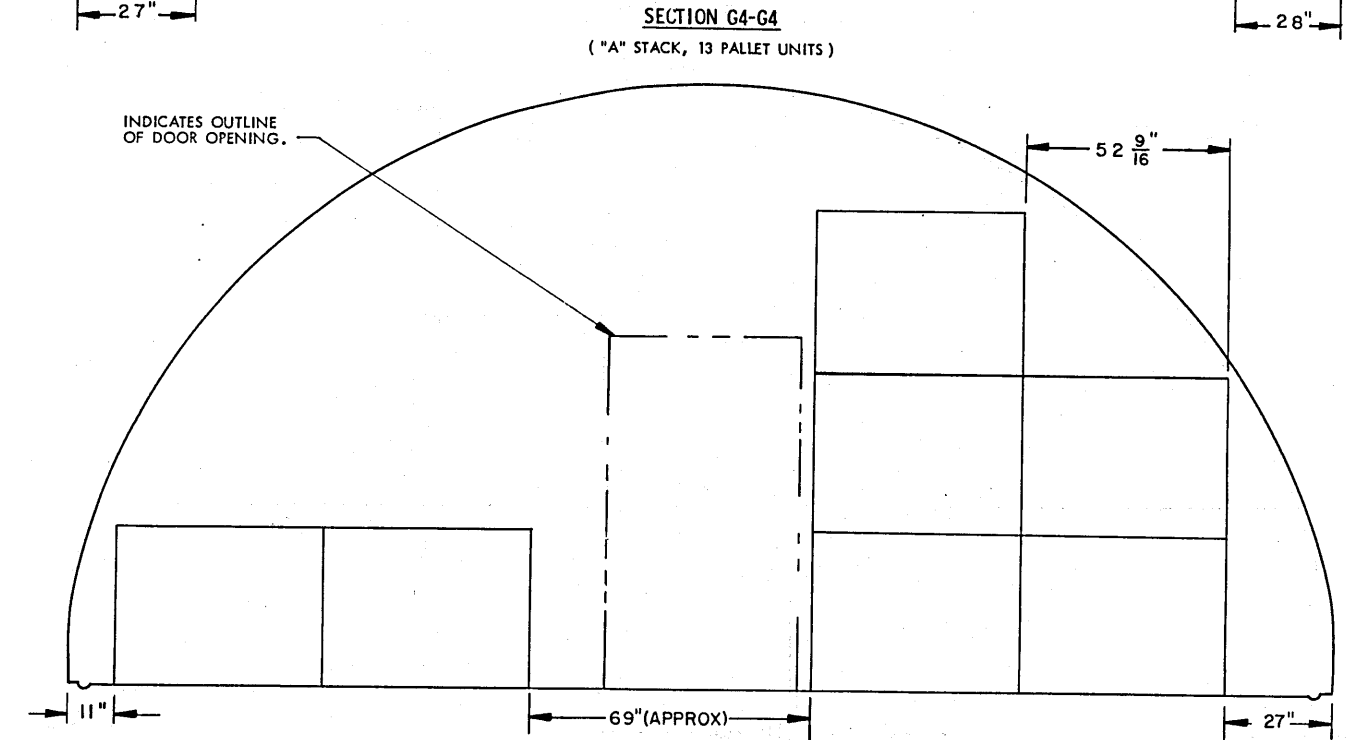

SECTION H4-H4 ("C" STACK, 7 PALLET UNITS)

STORAGE PROCEDURES FOR UNIT NO. 42 (DECREASED-HEIGHT UNIT)

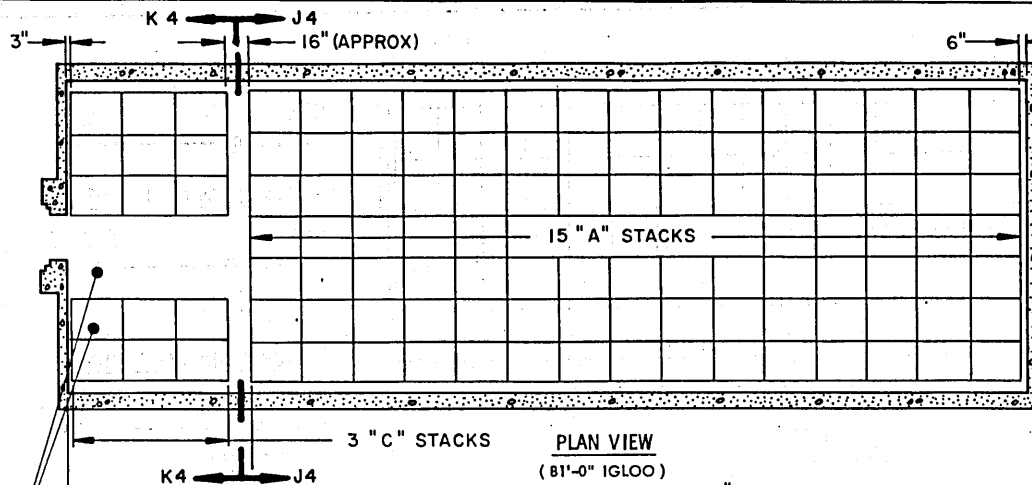

PLAN VIEW
(81'-0" IGLOO)

STORAGE IN 81'-0" IGLOO	
ITEM	QUANTITY
PALLET UNITS	216
* STORAGE IN 60'-8" IGLOO	
ITEM	QUANTITY
PALLET UNITS	157
* 11 A-STACKS	
2 C-STACKS	
** STORAGE IN 40'-4" IGLOO	
ITEM	QUANTITY
PALLET UNITS	99
** 6 A-STACKS	
3 C-STACKS	

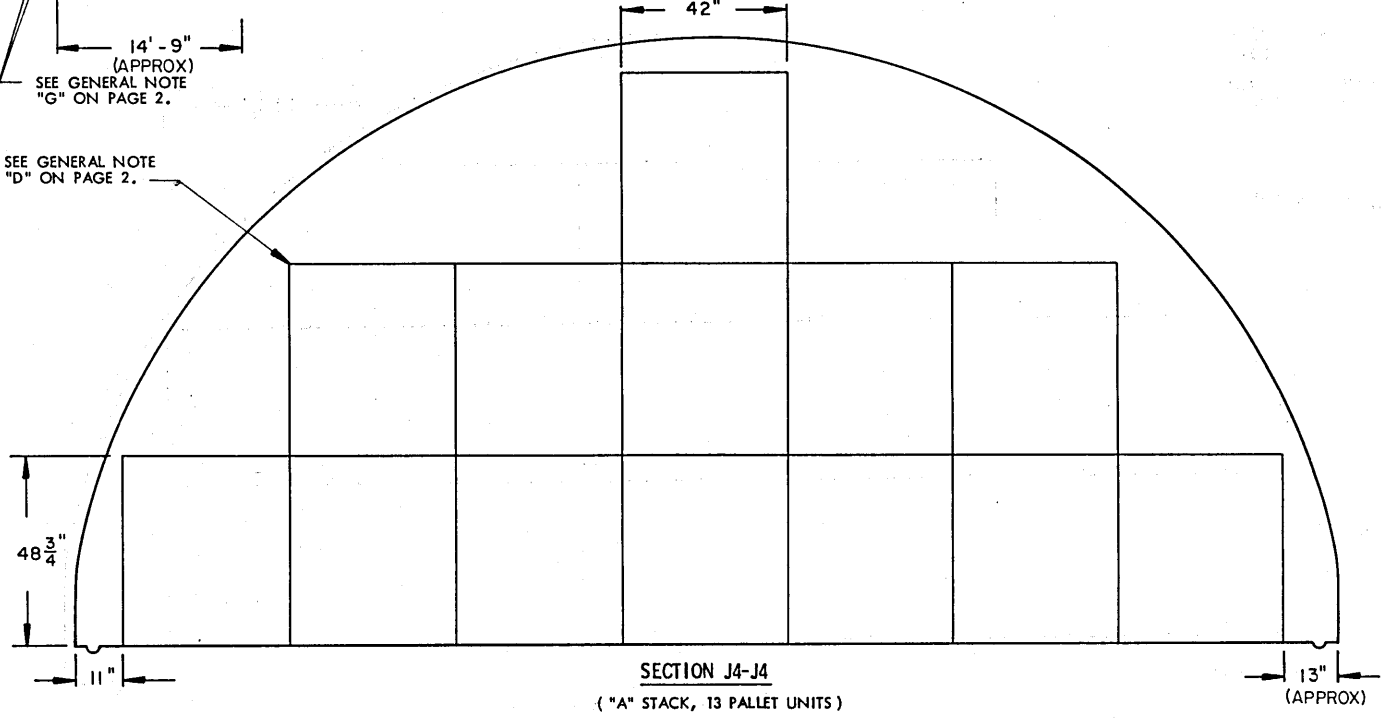

SECTION J4-J4
("A" STACK, 13 PALLET UNITS)

INDICATES OUTLINE OF DOOR OPENING.

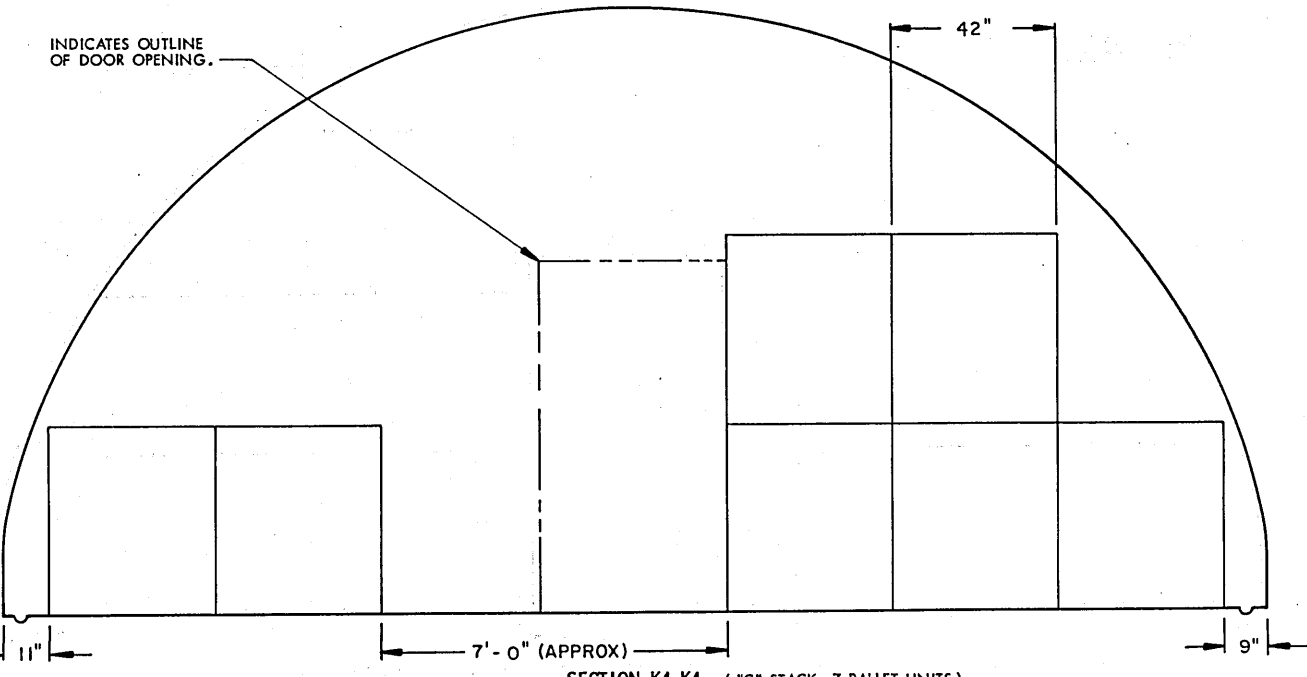

SECTION K4-K4 ("C" STACK, 7 PALLET UNITS)
STORAGE PROCEDURES FOR UNIT NO. 43

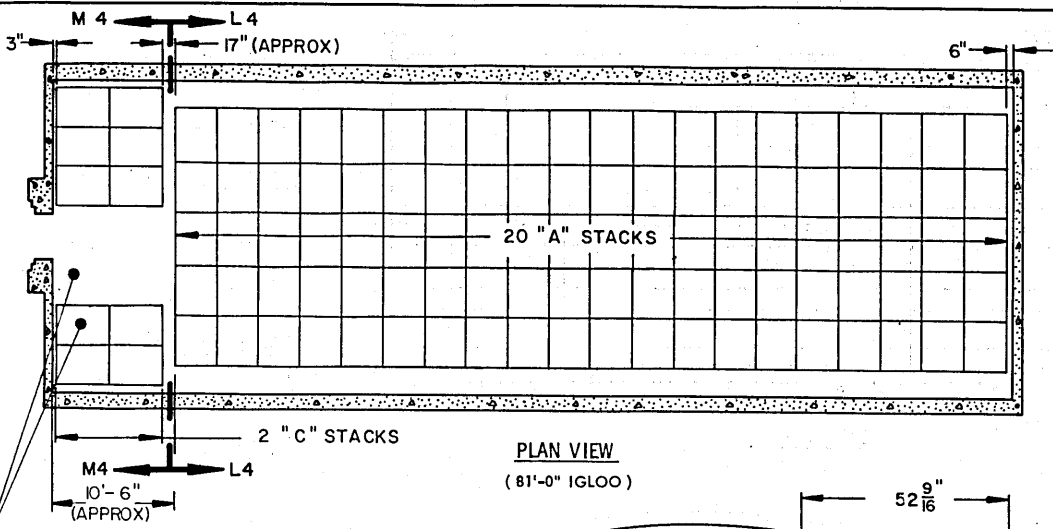

STORAGE IN 81'-0" IGLOO

ITEM	QUANTITY
PALLET UNITS -----	276

*** STORAGE IN 60'-8" IGLOO**

ITEM	QUANTITY
PALLET UNITS -----	198
* 14 A-STACKS	
2 C-STACKS	

**** STORAGE IN 40'-4" IGLOO**

ITEM	QUANTITY
PALLET UNITS -----	120
** 8 A-STACKS	
2 C-STACKS	

PLAN VIEW
(81'-0" IGLOO)

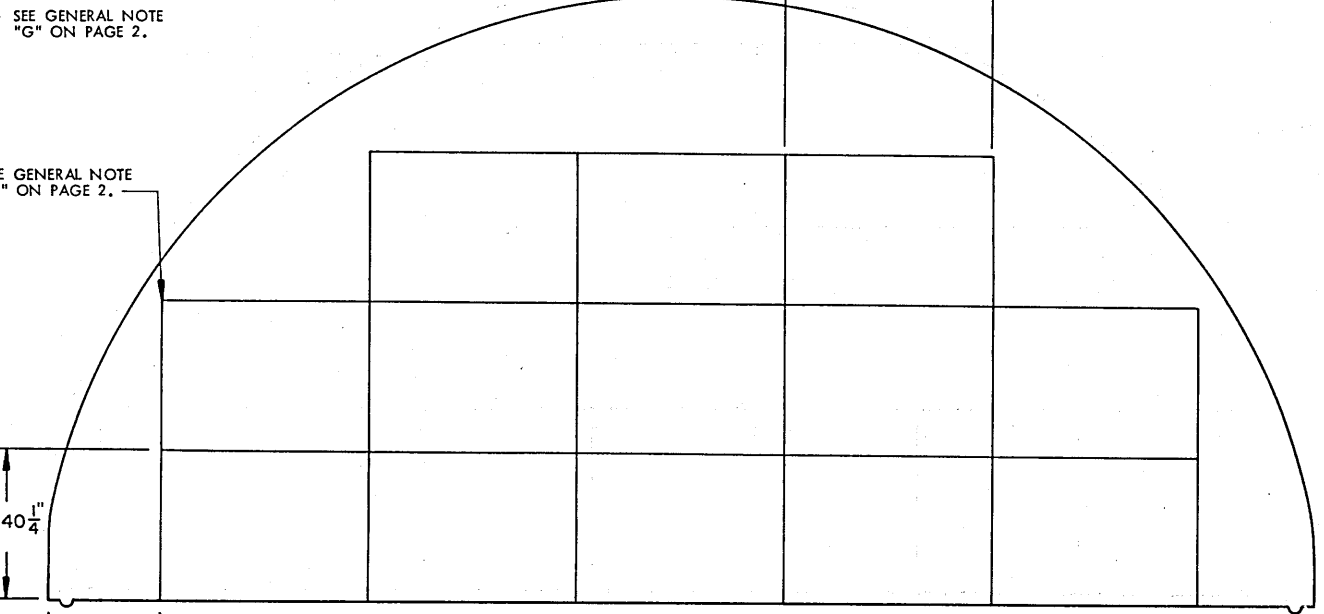

SECTION L4-L4
("A" STACK, 13 PALLET UNITS)

INDICATES OUTLINE OF DOOR OPENING.

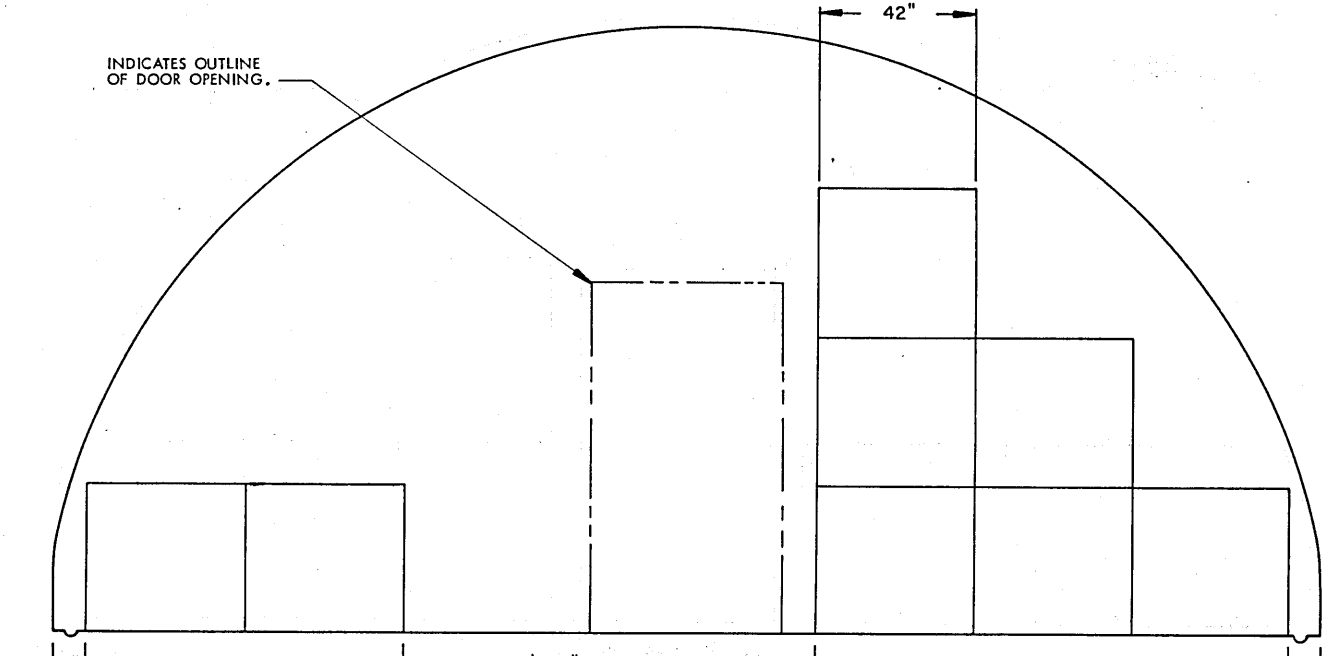

SECTION M4-M4 ("C" STACK, 8 PALLET UNITS)

STORAGE PROCEDURES FOR UNIT NO. 43 (DECREASED-HEIGHT UNIT)

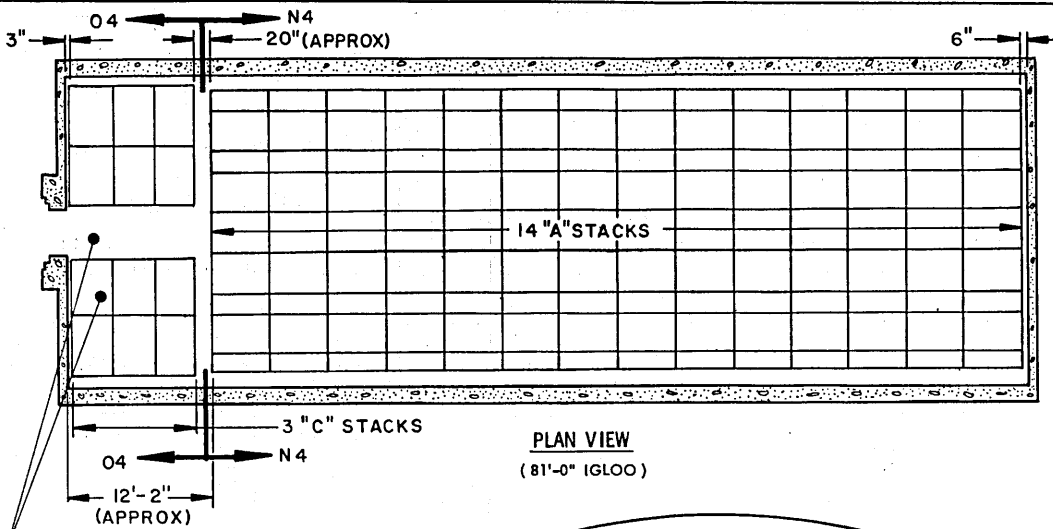

PLAN VIEW
(81'-0" IGLOO)

SEE GENERAL NOTE "G" ON PAGE 2.

SEE GENERAL NOTE "D" ON PAGE 2.

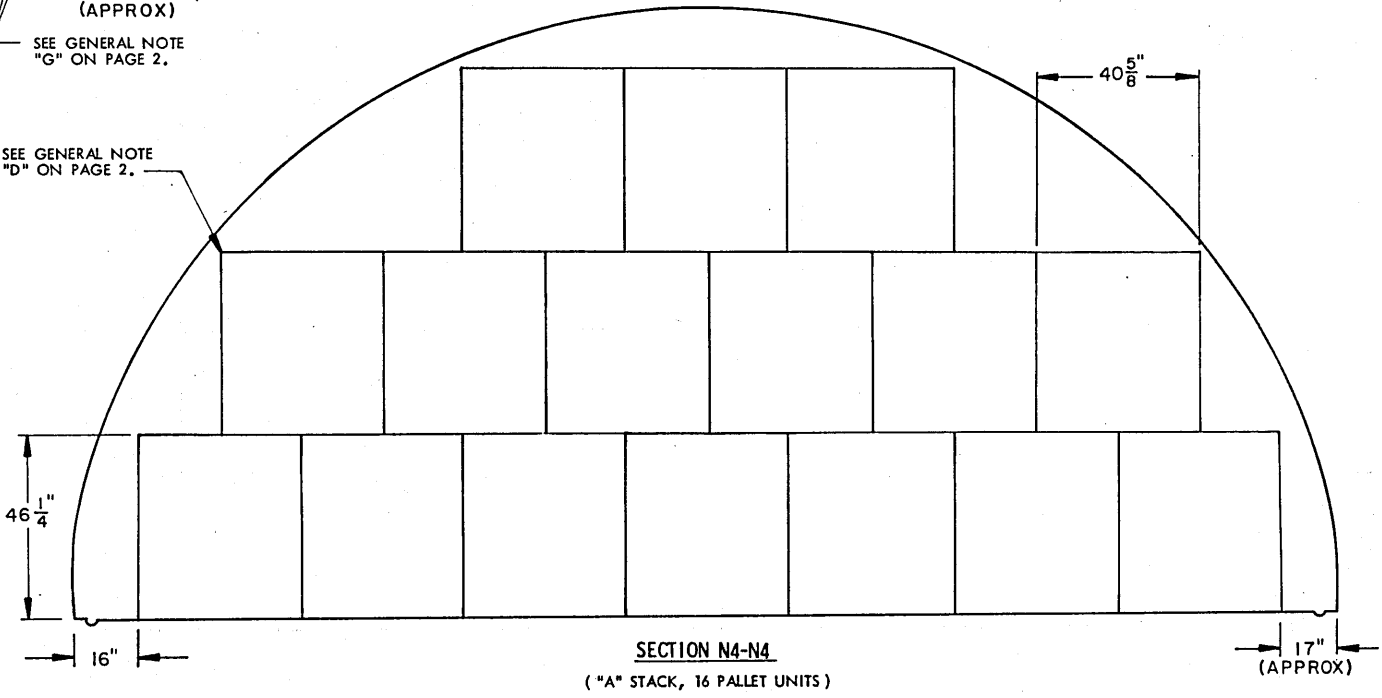

SECTION N4-N4
("A" STACK, 16 PALLET UNITS)

INDICATES OUTLINE OF DOOR OPENING.

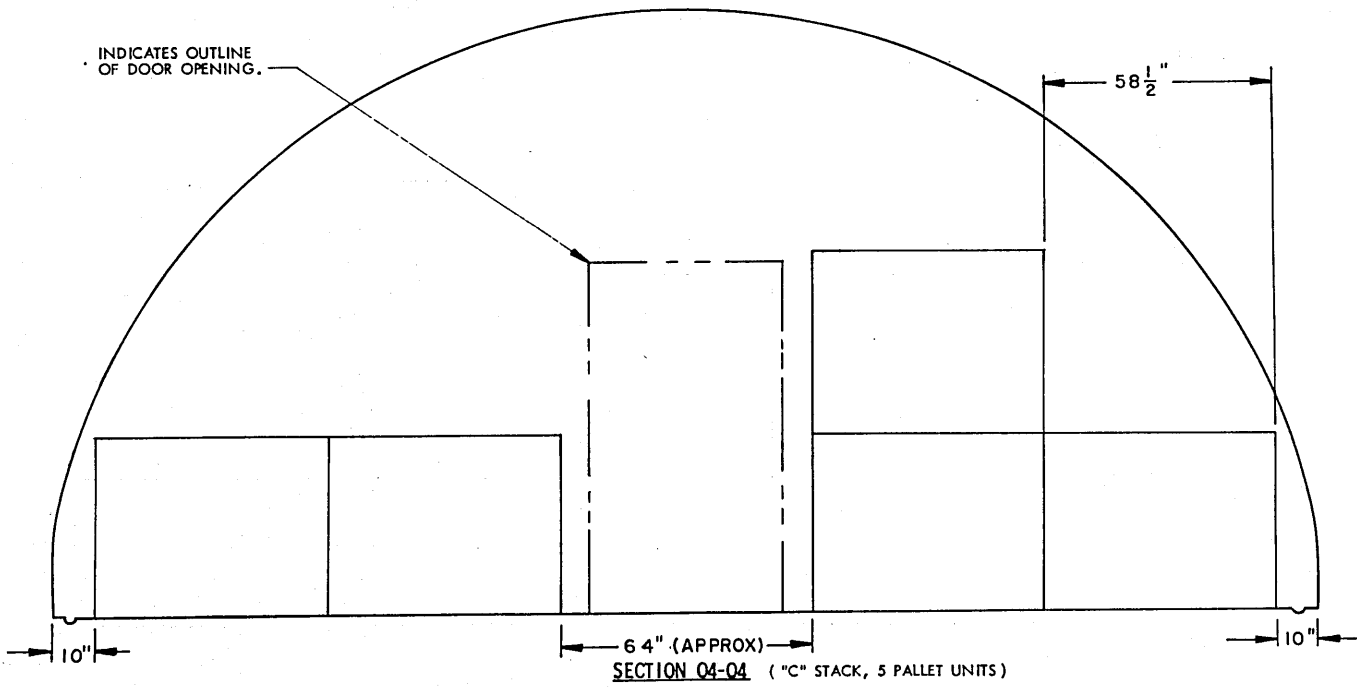

SECTION O4-O4
("C" STACK, 5 PALLET UNITS)

STORAGE IN 81'-0" IGLOO

ITEM	QUANTITY
PALLET UNITS	239

*** STORAGE IN 60'-8" IGLOO**

ITEM	QUANTITY
PALLET UNITS	175
* 10 A-STACKS	
3 C-STACKS	

**** STORAGE IN 40'-4" IGLOO**

ITEM	QUANTITY
PALLET UNITS	111
** 6 A-STACKS	
3 C-STACKS	

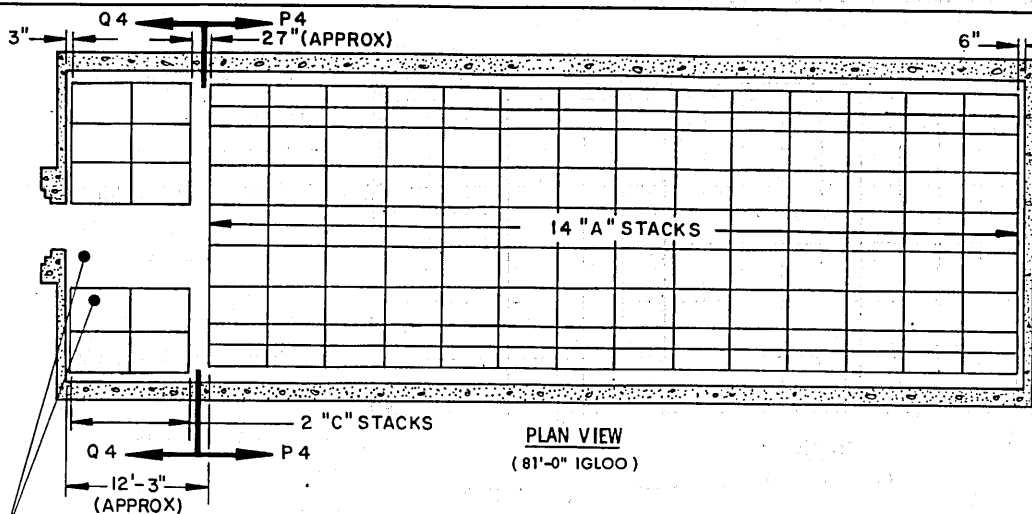

PLAN VIEW
(81'-0" IGLOO)

STORAGE IN 81'-0" IGLOO

ITEM	QUANTITY
PALLET UNITS	284

*** STORAGE IN 60'-8" IGLOO**

ITEM	QUANTITY
PALLET UNITS	208
* 10 A-STACKS	
2 C-STACKS	

**** STORAGE IN 40'-4" IGLOO**

ITEM	QUANTITY
PALLET UNITS	132
** 6 A-STACKS	
2 C-STACKS	

SEE GENERAL NOTE "G" ON PAGE 2.

SEE GENERAL NOTE "D" ON PAGE 2.

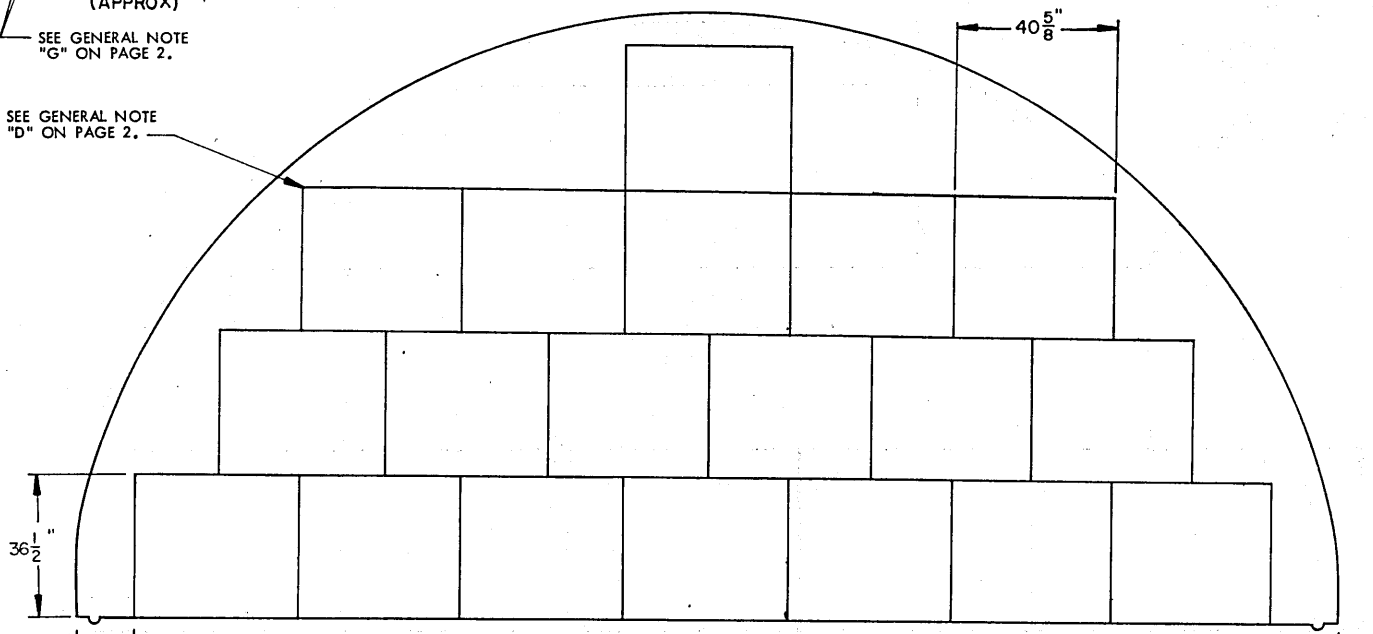

SECTION P4-P4
("A" STACK, 19 PALLET UNITS)

INDICATES OUTLINE OF DOOR OPENING.

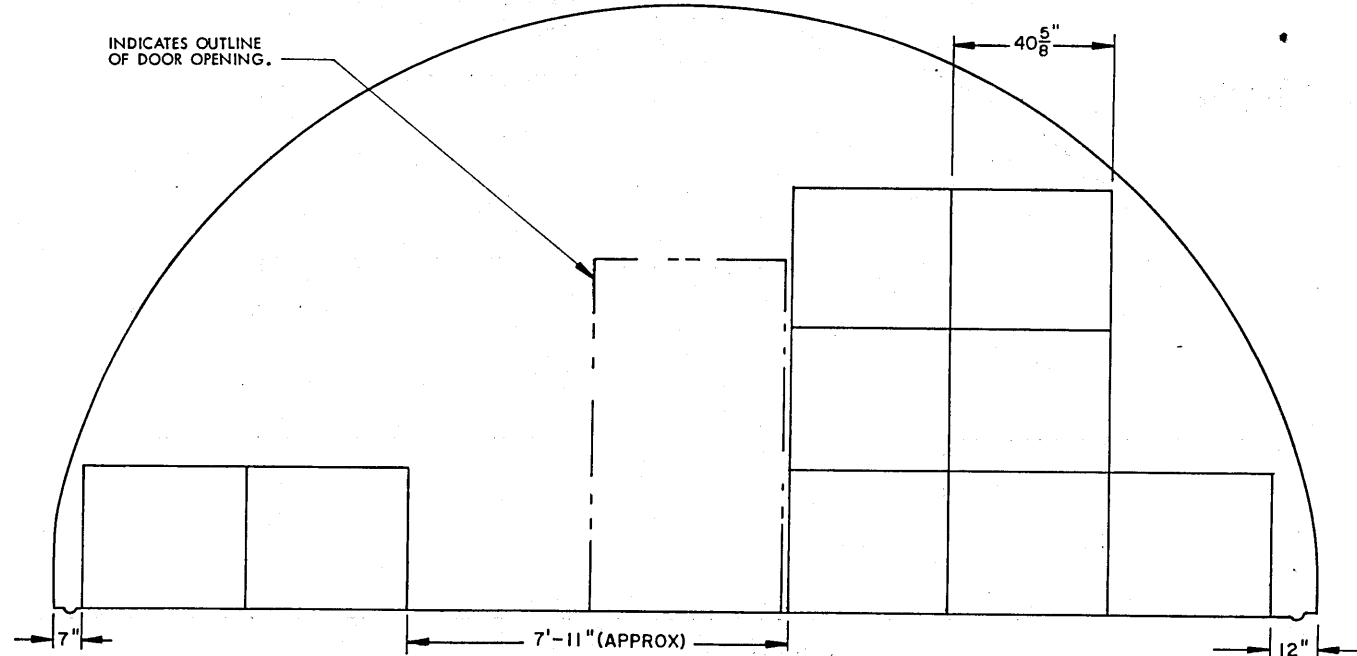

SECTION Q4-Q4 ("C" STACK, 9 PALLET UNITS)

STORAGE PROCEDURES FOR UNIT NO. 44 (DECREASED-HEIGHT UNIT)

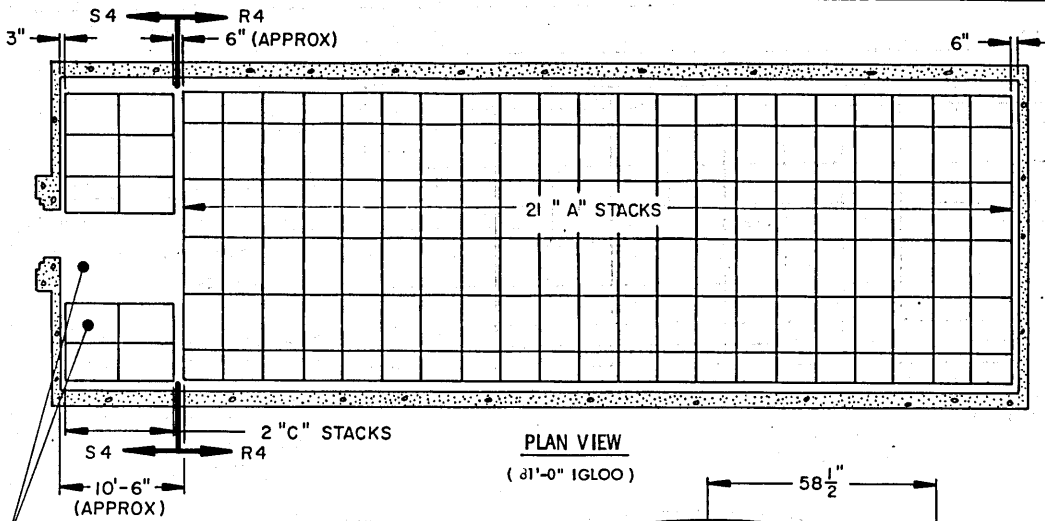

STORAGE IN 81'-0" IGLOO

ITEM	QUANTITY
PALLET UNITS	247

*** STORAGE IN 60'-8" IGLOO**

ITEM	QUANTITY
PALLET UNITS	170

- * 14 A-STACKS
- 2 C-STACKS

**** STORAGE IN 40'-4" IGLOO**

ITEM	QUANTITY
PALLET UNITS	104

- ** 8 A-STACKS
- 2 C-STACKS

PLAN VIEW
(11'-0" IGLOO)

58 1/2"

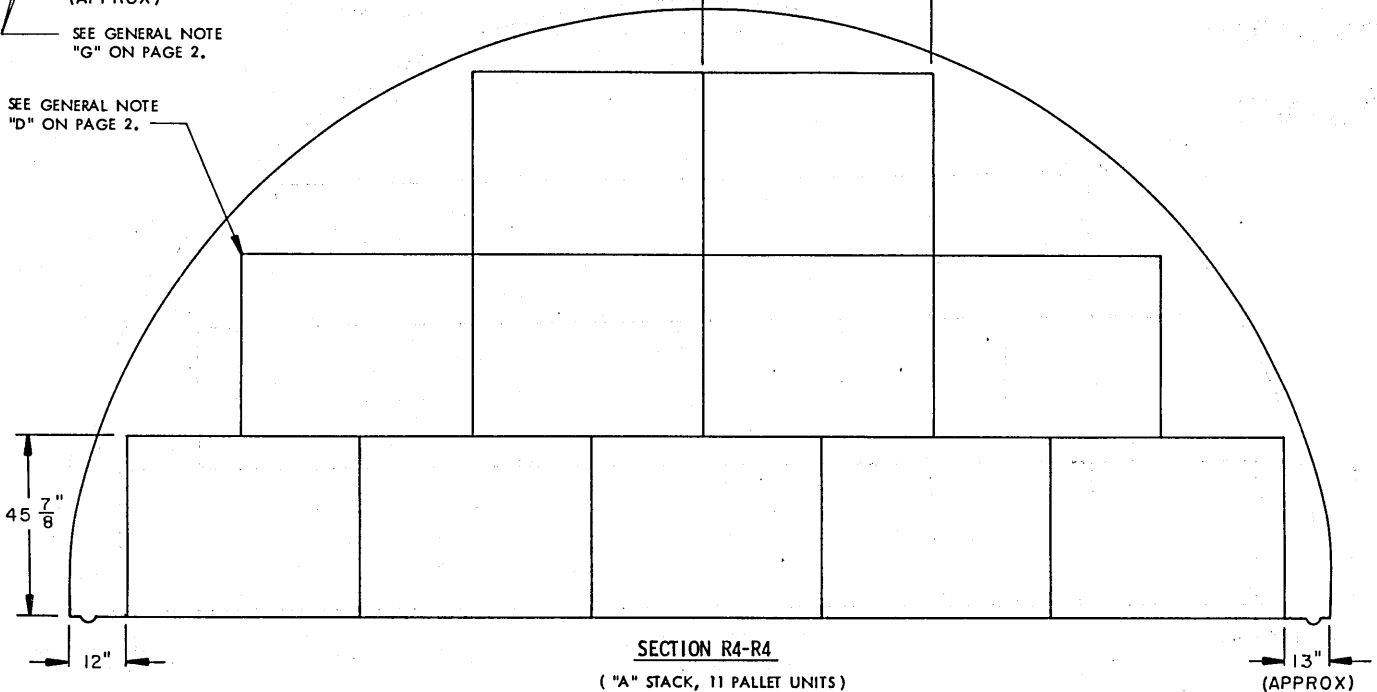

INDICATES OUTLINE OF DOOR OPENING.

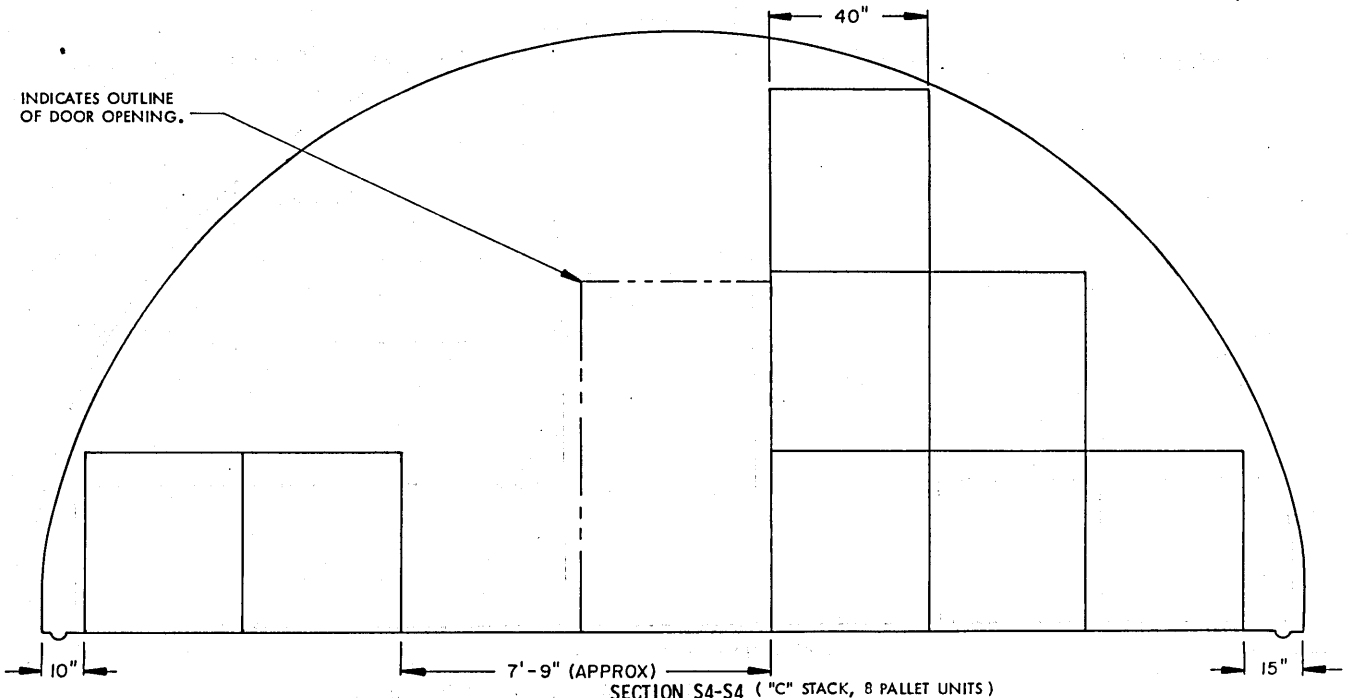

STORAGE PROCEDURES FOR UNIT NO. 45

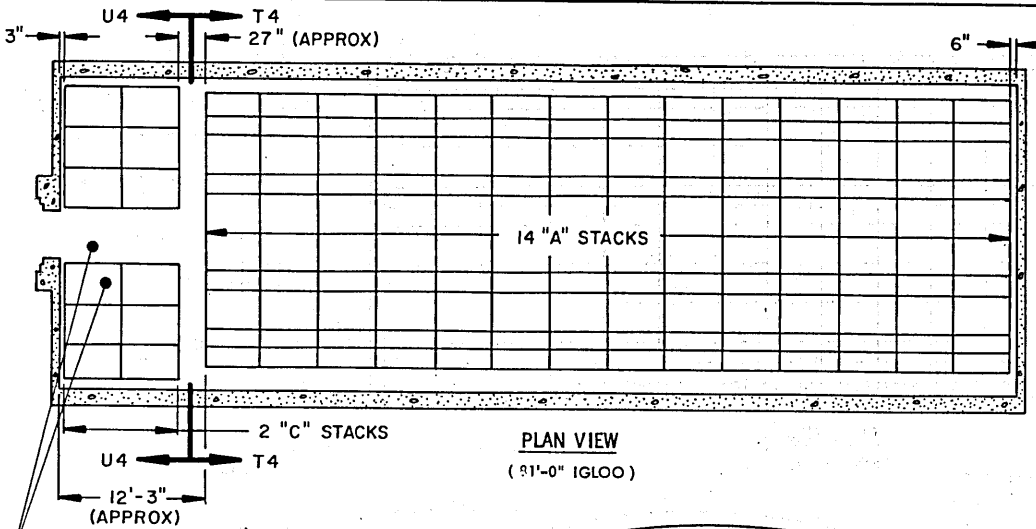

STORAGE IN 81'-0" IGLOO

ITEM	QUANTITY
PALLET UNITS	300

*** STORAGE IN 60'-8" IGLOO**

ITEM	QUANTITY
PALLET UNITS	220
10 A-STACKS	
2 C-STACKS	

**** STORAGE IN 40'-4" IGLOO**

ITEM	QUANTITY
PALLET UNITS	140
6 A-STACKS	
2 C-STACKS	

PLAN VIEW
(81'-0" IGLOO)

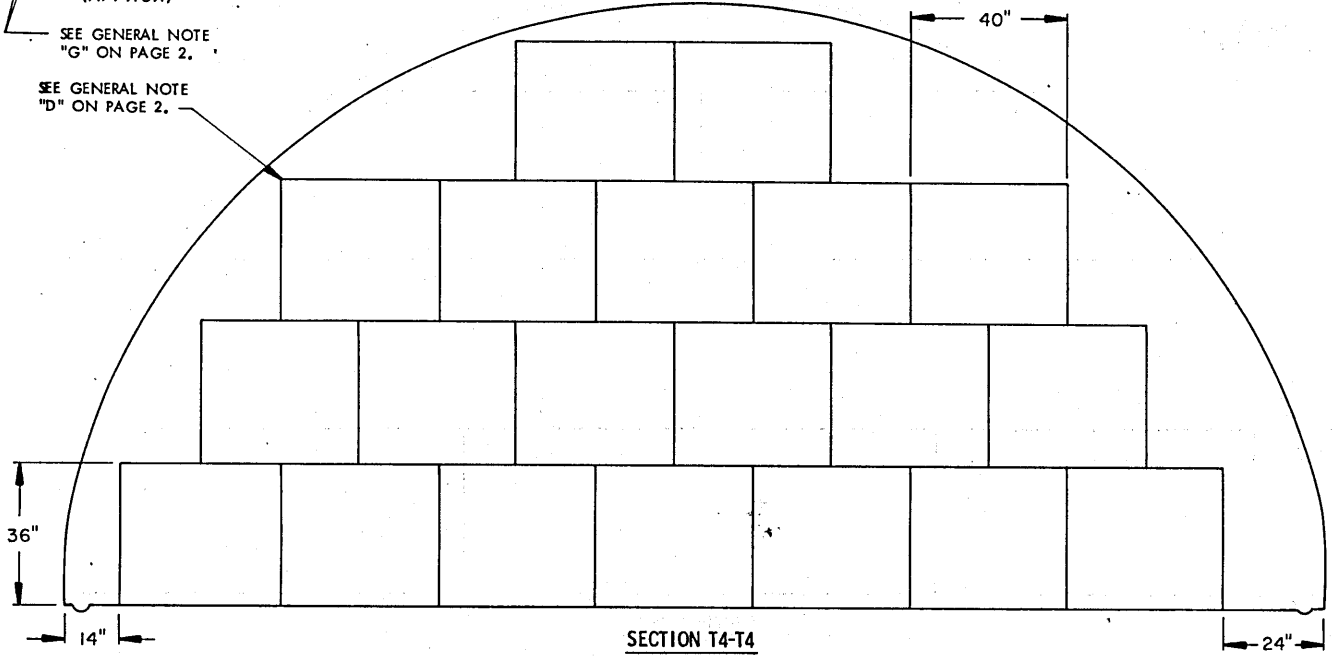

SECTION T4-T4
("A" STACK, 20 PALLET UNITS)

INDICATES OUTLINE OF DOOR OPENING.

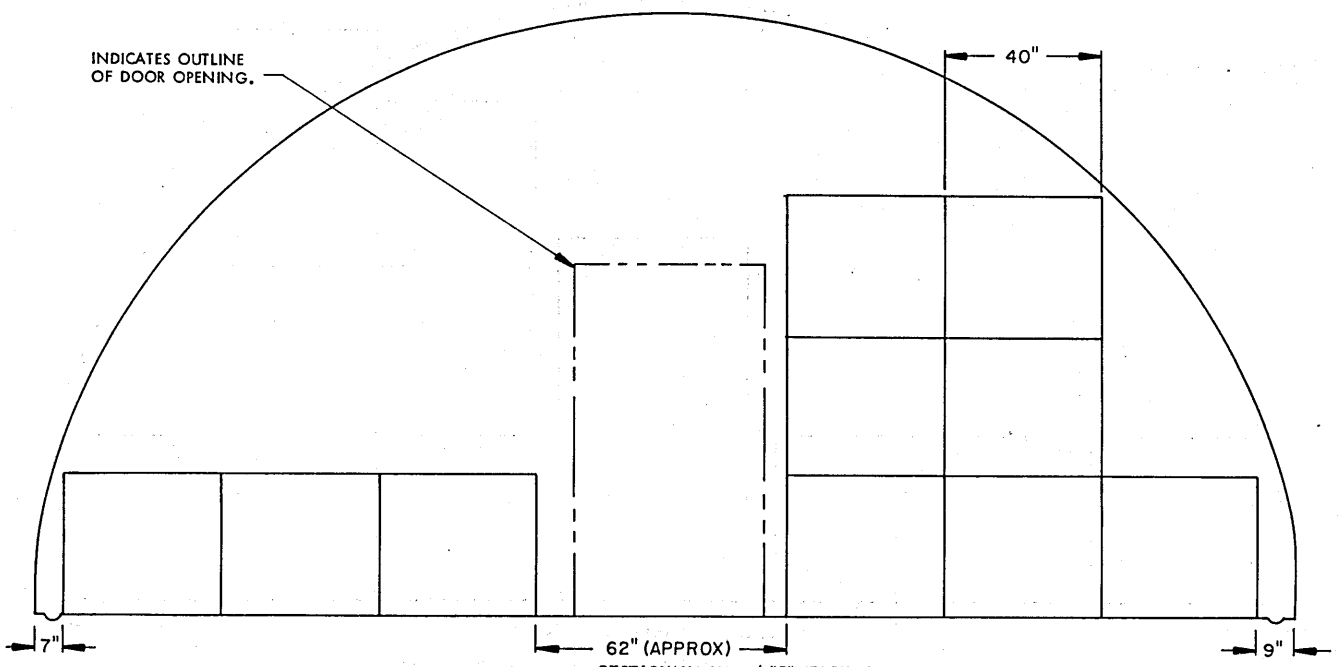

SECTION U4-U4 ("C" STACK, 10 PALLET UNITS)

STORAGE PROCEDURES FOR UNIT NO. 45 (DECREASED-HEIGHT UNIT)

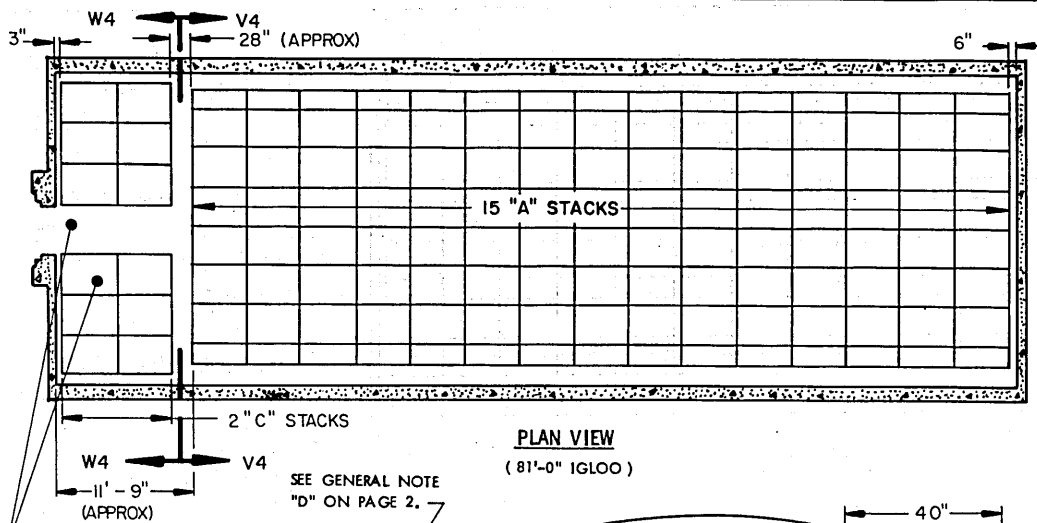

PLAN VIEW
(81'-0" IGLOO)

STORAGE IN 81'-0" IGLOO

ITEM	QUANTITY
PALLET UNITS	273

*** STORAGE IN 60'-8" IGLOO**

ITEM	QUANTITY
PALLET UNITS	197

- * 10 A-STACKS
- 3 C-STACKS

**** STORAGE IN 40'-4" IGLOO**

ITEM	QUANTITY
PALLET UNITS	120

- ** 6 A-STACKS
- 2 C-STACKS

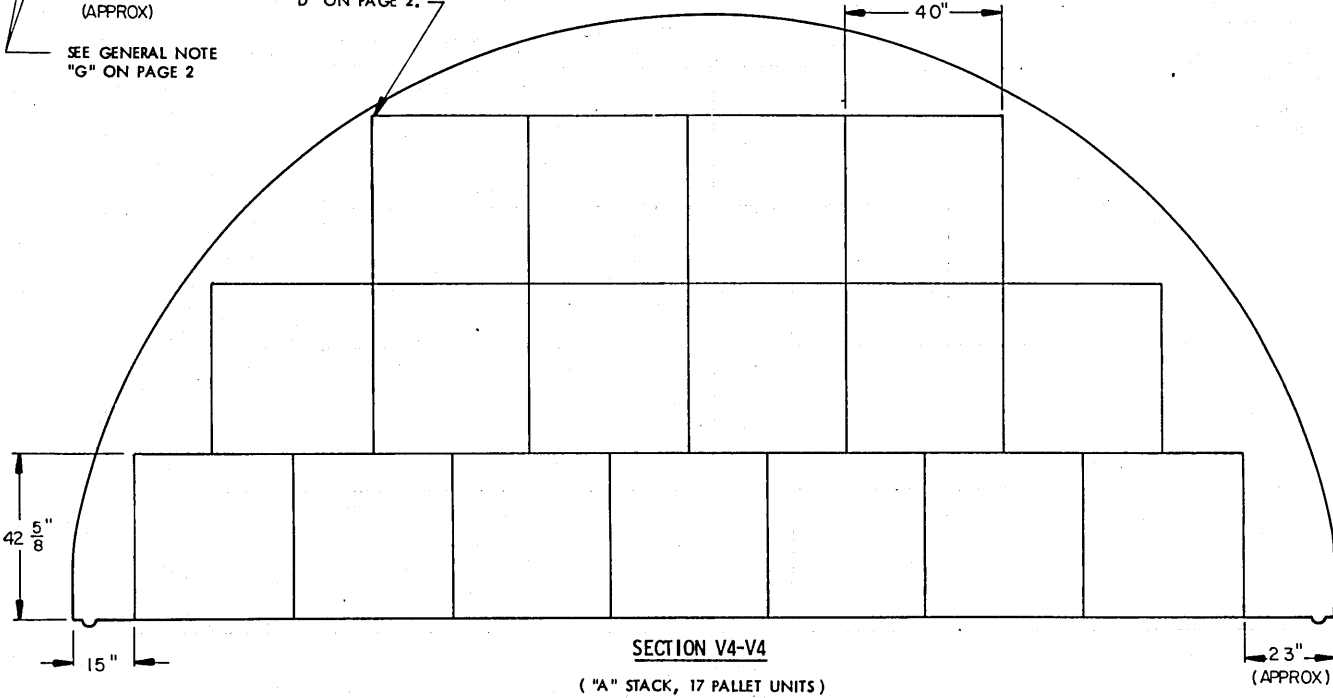

INDICATES OUTLINE OF DOOR OPENING.

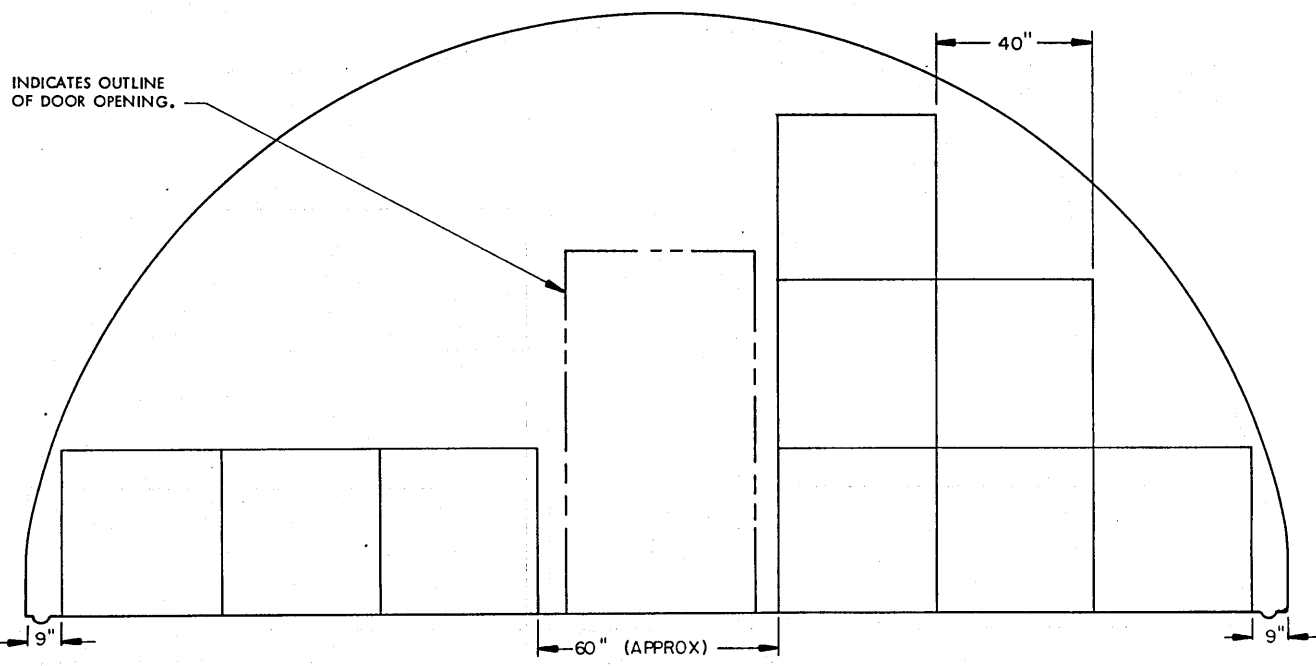

SECTION W4-W4 ("C" STACK, 9 PALLET UNITS)

STORAGE PROCEDURES FOR UNIT NO. 46

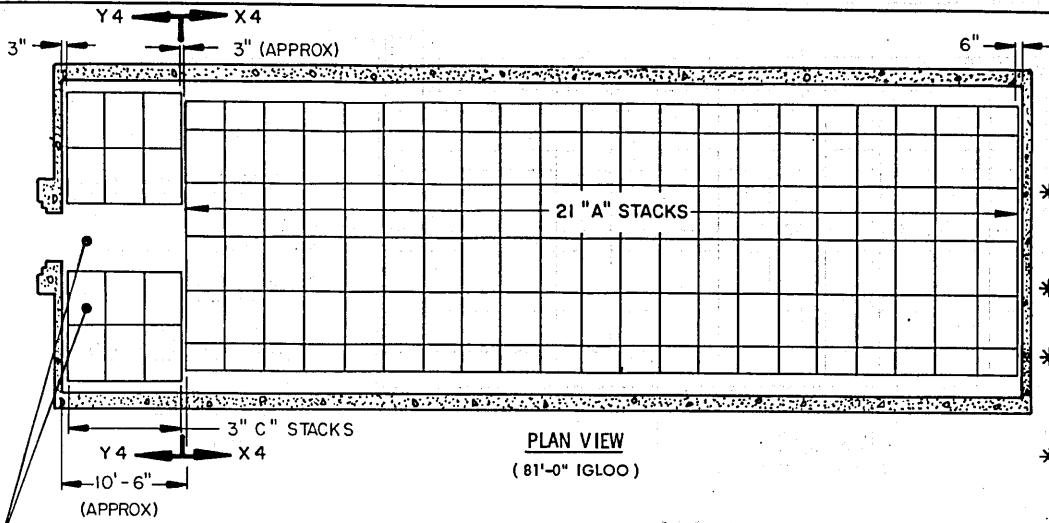

STORAGE IN 81'-0" IGLOO

ITEM	QUANTITY
PALLET UNITS -----	204

*** STORAGE IN 60'-8" IGLOO**

ITEM	QUANTITY
PALLET UNITS -----	141
* 14 A-STACKS	
3 C-STACKS	

**** STORAGE IN 40'-4" IGLOO**

ITEM	QUANTITY
PALLET UNITS -----	87
** 8 A-STACKS	
3 C-STACKS	

PLAN VIEW
(81'-0" IGLOO)

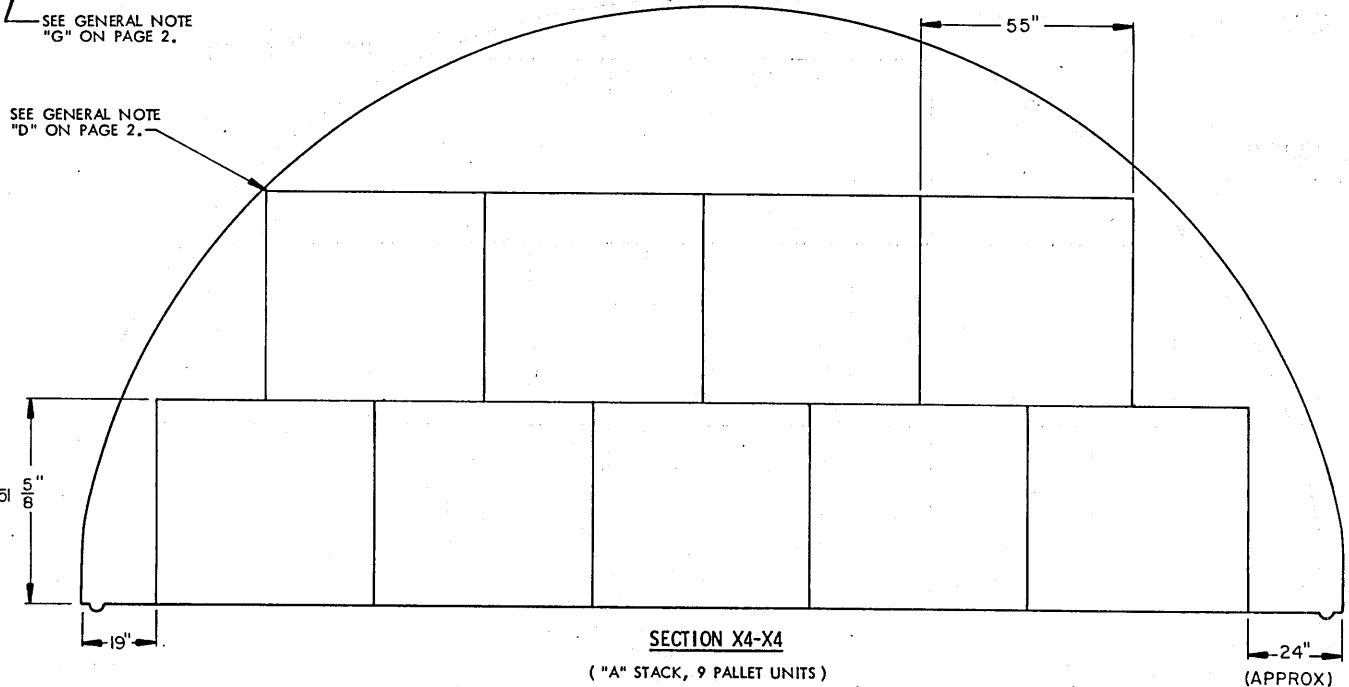

SECTION X4-X4

("A" STACK, 9 PALLET UNITS)

INDICATES OUTLINE OF DOOR OPENING.

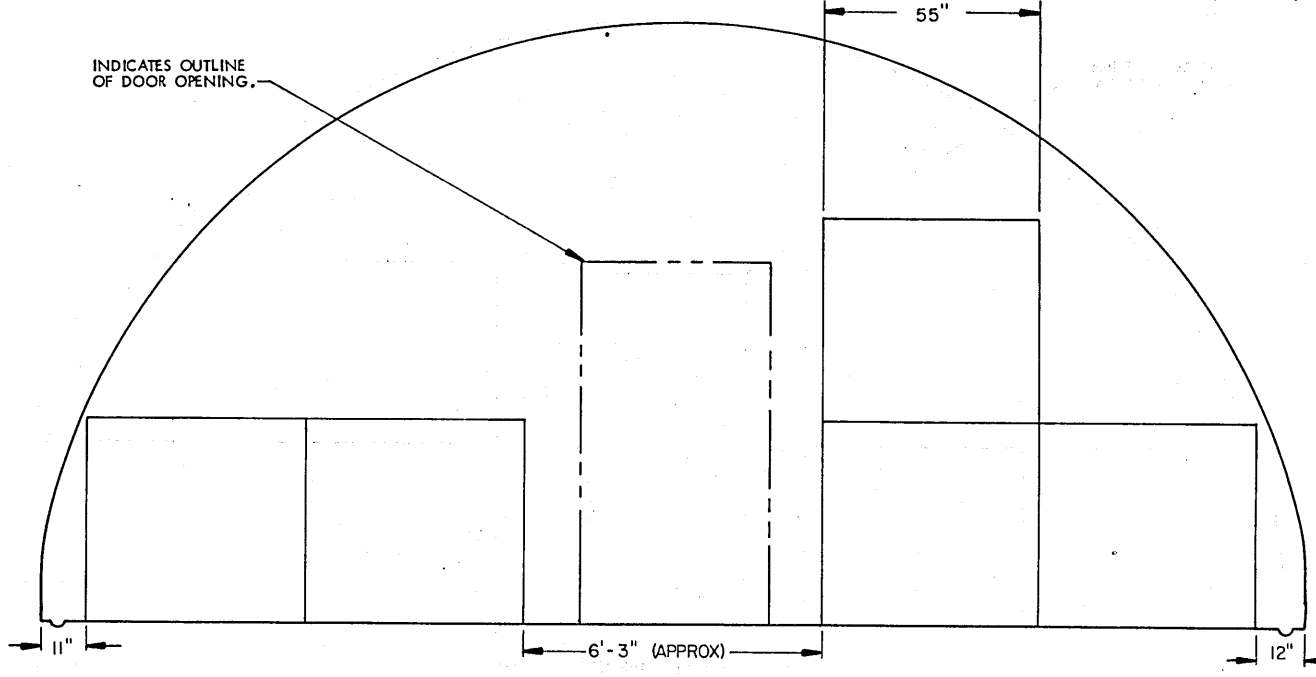

SECTION Y4-Y4

("C" STACK, 5 PALLET UNITS)

STORAGE PROCEDURES FOR UNIT NO. 46 (INCREASED-HEIGHT UNIT)

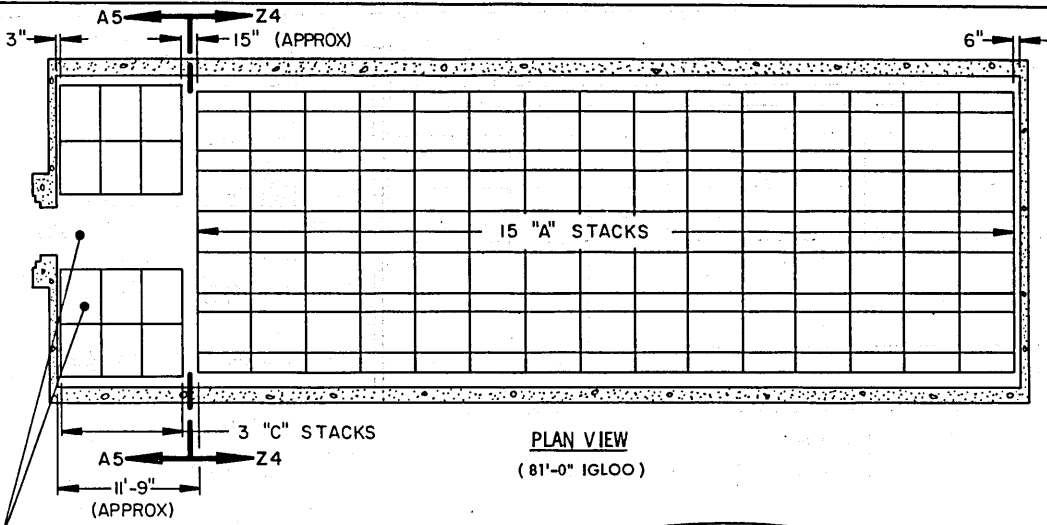

PLAN VIEW
(81'-0" IGLOO)

SEE GENERAL NOTE
"G" ON PAGE 2.

SEE GENERAL NOTE
"D" ON PAGE 2.

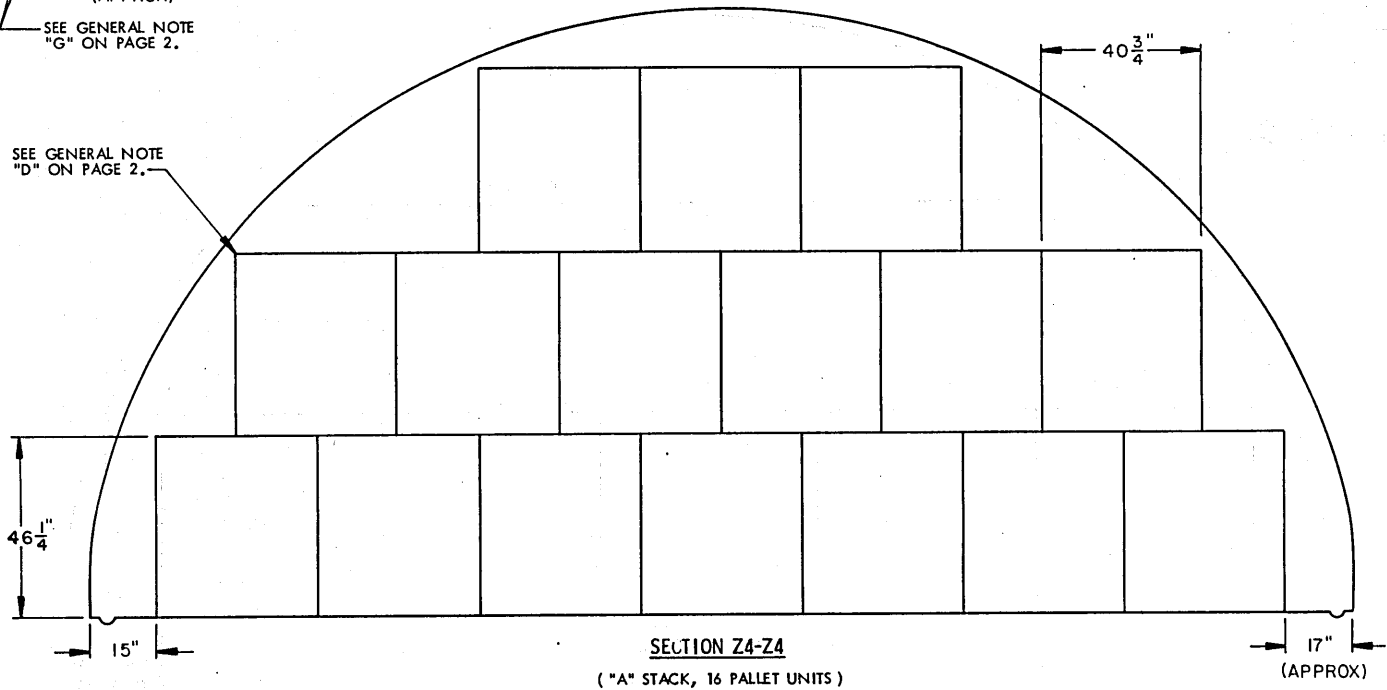

SECTION Z4-Z4
("A" STACK, 16 PALLET UNITS)

INDICATES OUTLINE
OF DOOR OPENING.

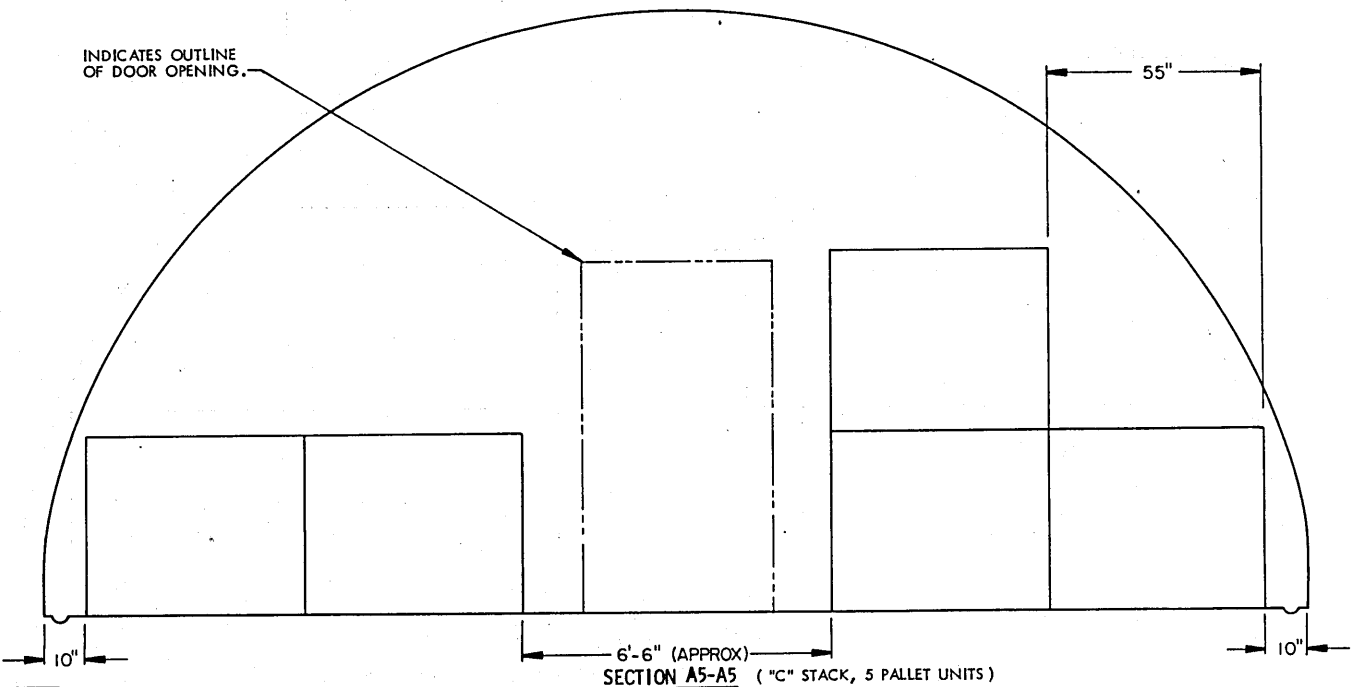

SECTION A5-A5 ("C" STACK, 5 PALLET UNITS)
STORAGE PROCEDURES FOR UNIT NO. 47

STORAGE IN 81'-0" IGLOO

ITEM	QUANTITY
PALLET UNITS	255

* **STORAGE IN 60'-8" IGLOO**

ITEM	QUANTITY
PALLET UNITS	180

- * * 10 A-STACKS
- 4 C-STACKS

* **STORAGE IN 40'-4" IGLOO**

ITEM	QUANTITY
PALLET UNITS	111

- * * 6 A-STACKS
- 3 C-STACKS

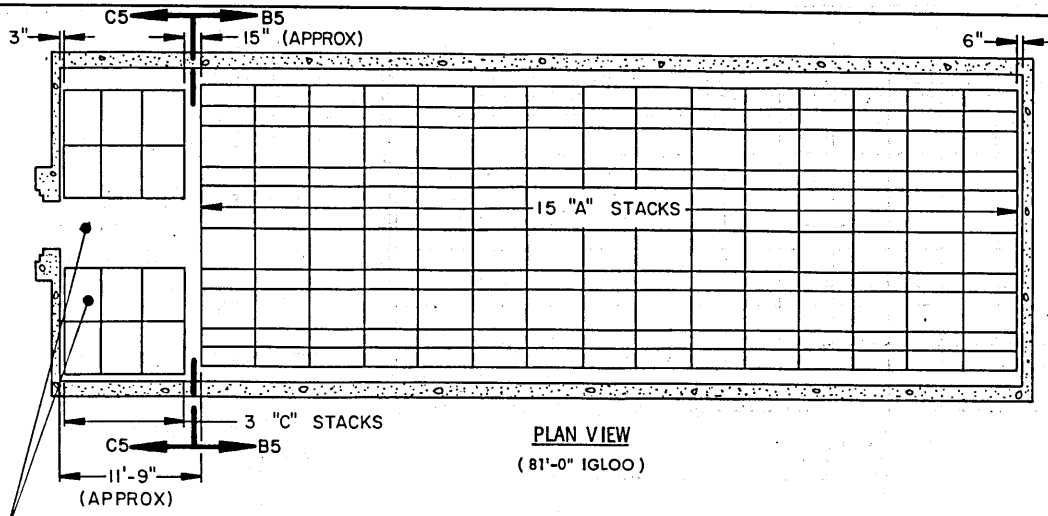

STORAGE IN 81'-0" IGLOO	
ITEM	QUANTITY
PALLET UNITS	321
* STORAGE IN 60'-8" IGLOO	
ITEM	QUANTITY
PALLET UNITS	228
* 10 A-STACKS	4 C-STACKS
* STORAGE IN 40'-4" IGLOO	
ITEM	QUANTITY
PALLET UNITS	141
* 6 A-STACKS	3 C-STACKS

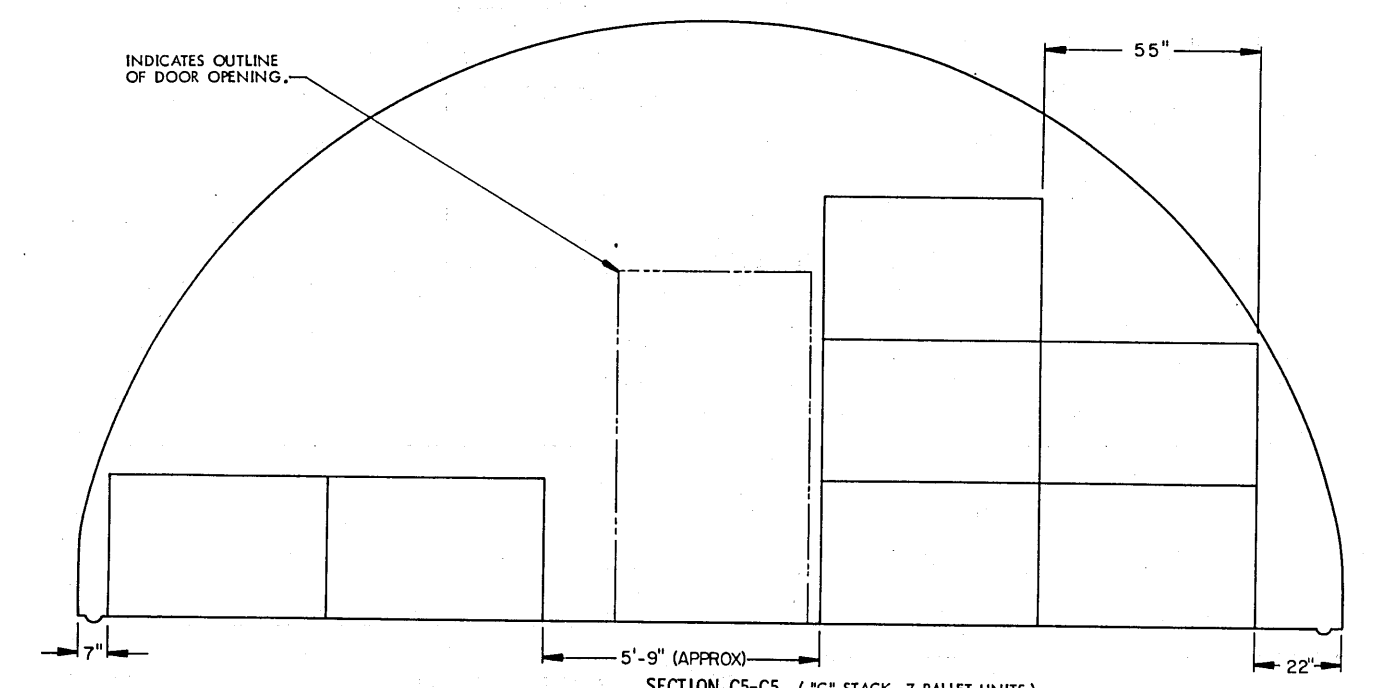
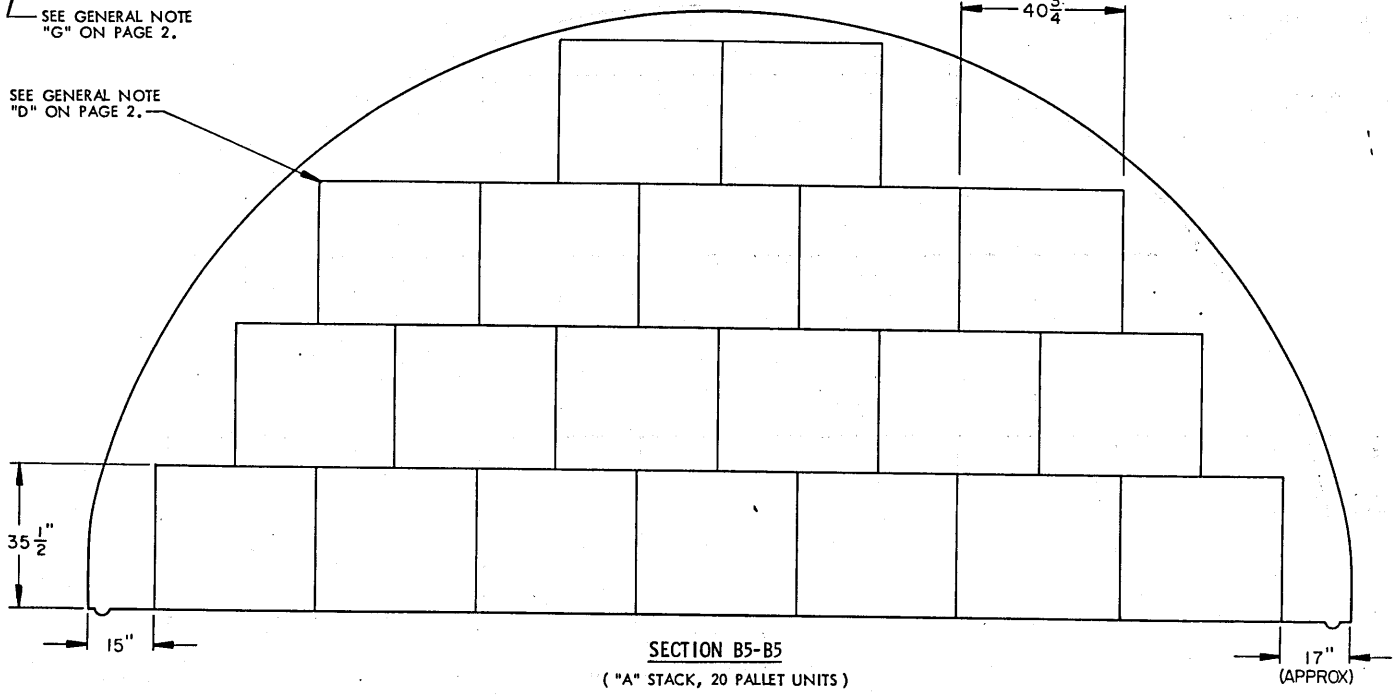

STORAGE PROCEDURES FOR UNIT NO. 47 (DECREASED-HEIGHT UNIT)

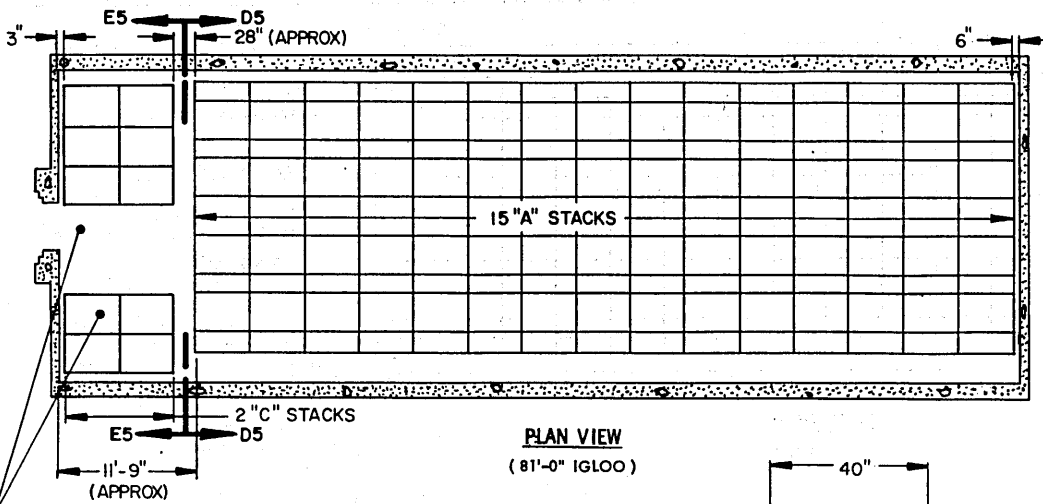

STORAGE IN 81'-0" IGLOO	
ITEM	QUANTITY
PALLET UNITS	256
* STORAGE IN 60'-8" IGLOO	
ITEM	QUANTITY
PALLET UNITS	184
* 10 A-STACKS	
3 C-STACKS	
** STORAGE IN 40'-4" IGLOO	
ITEM	QUANTITY
PALLET UNITS	112
** 6 A-STACKS	
2 C-STACKS	

SEE GENERAL NOTE "G" ON PAGE 2.

SEE GENERAL NOTE "D" ON PAGE 2.

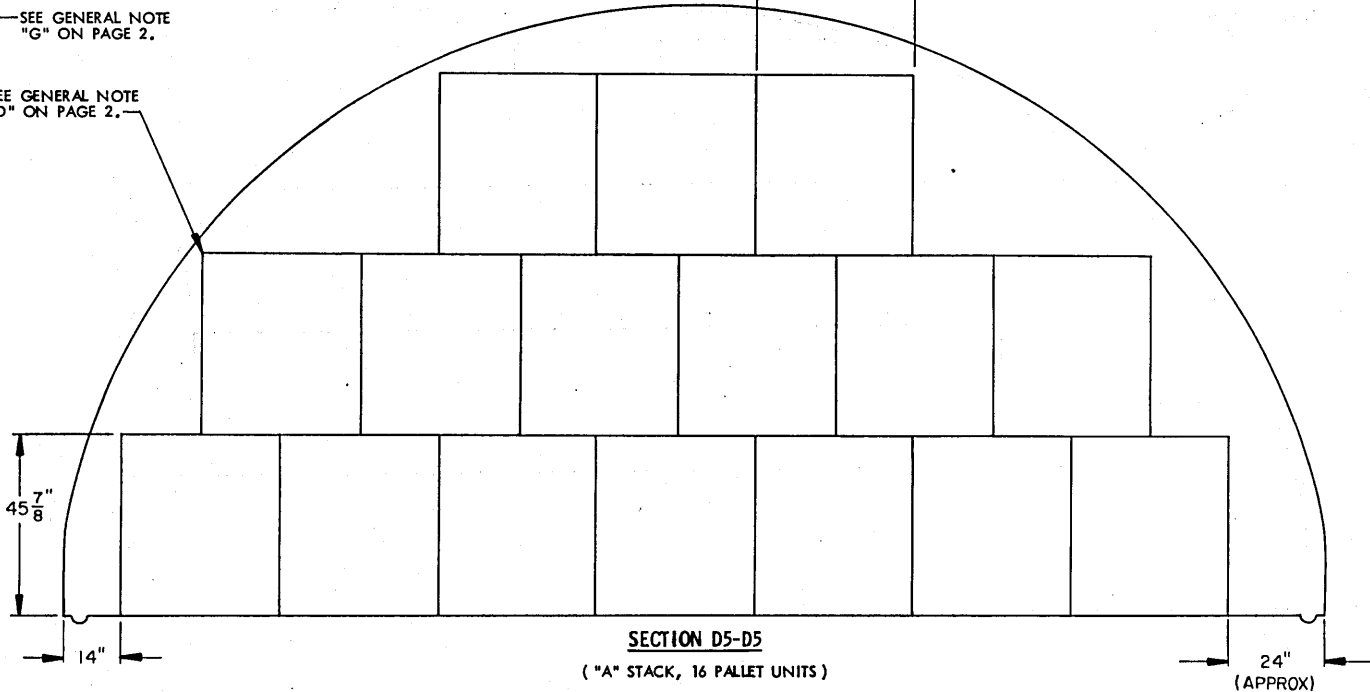

INDICATES OUTLINE OF DOOR OPENING.

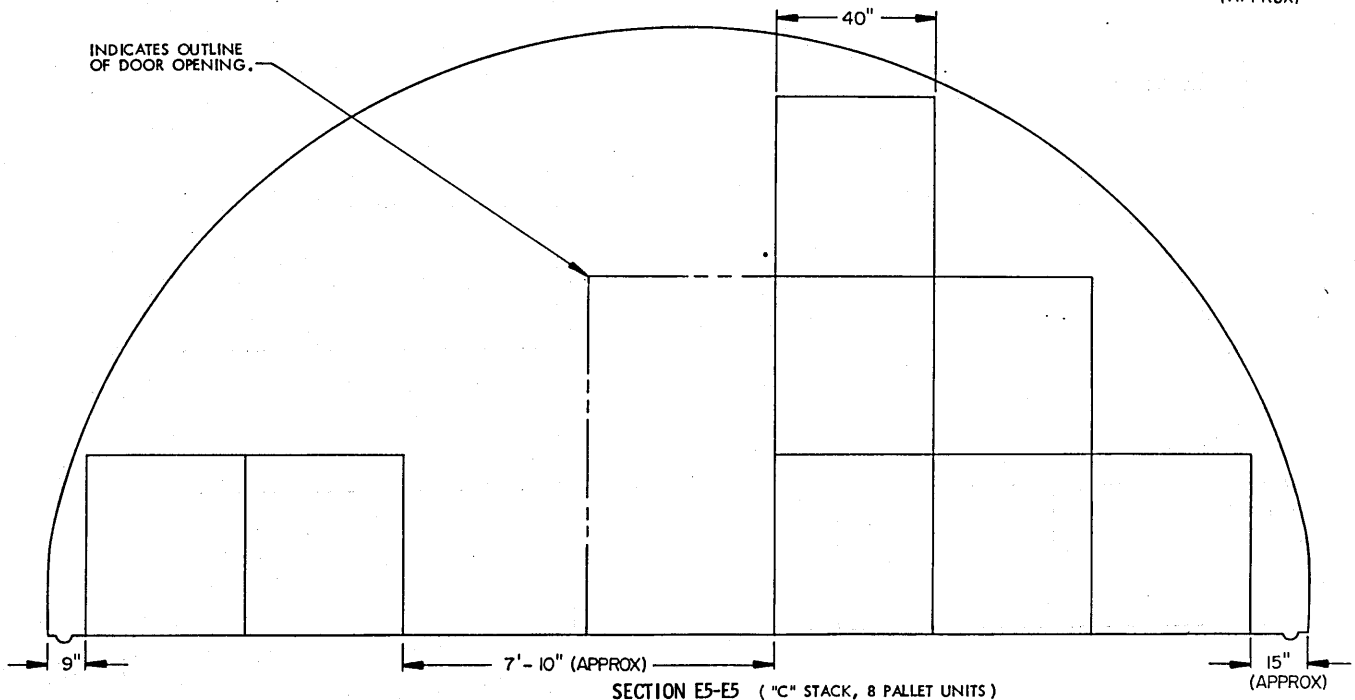

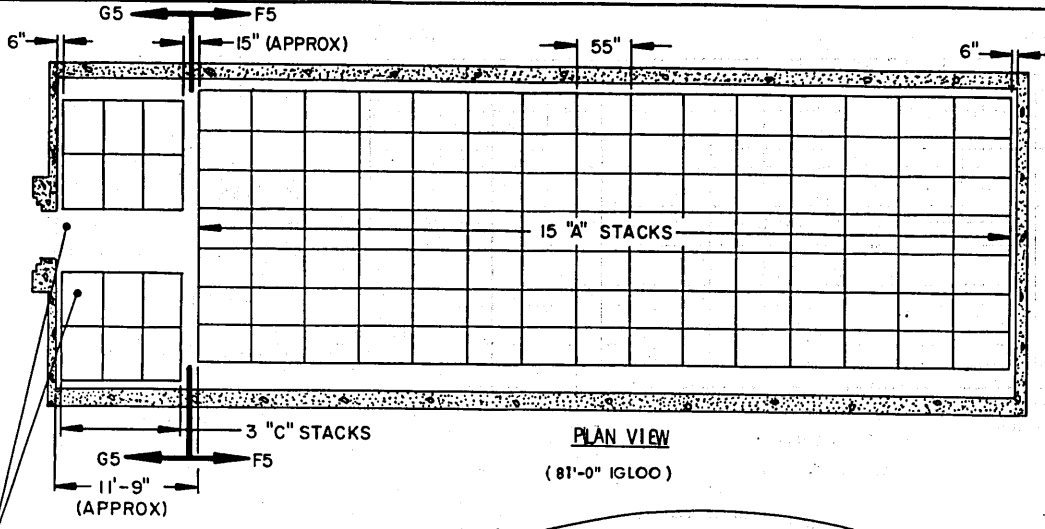

STORAGE IN 81'-0" IGLOO	
ITEM	QUANTITY
PALLET UNITS-----	321
* STORAGE IN 60'-8" IGLOO	
ITEM	QUANTITY
PALLET UNITS-----	221
* 10 A-STACKS	
3 C-STACKS	
** STORAGE IN 40'-4" IGLOO	
ITEM	QUANTITY
PALLET UNITS-----	141
** 6 A-STACKS	
3 C-STACKS	

SEE GENERAL NOTE "G" ON PAGE 2.

SEE GENERAL NOTE "D" ON PAGE 2.

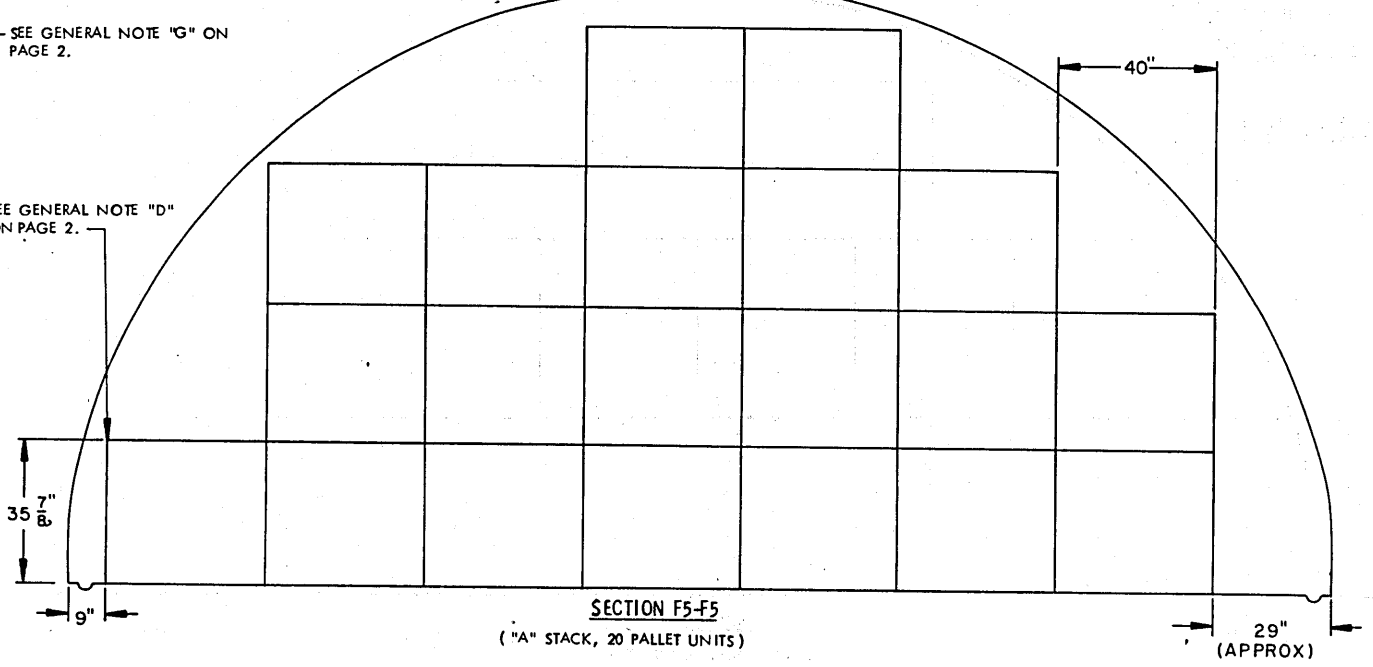

INDICATES OUTLINE OF DOOR OPENING.

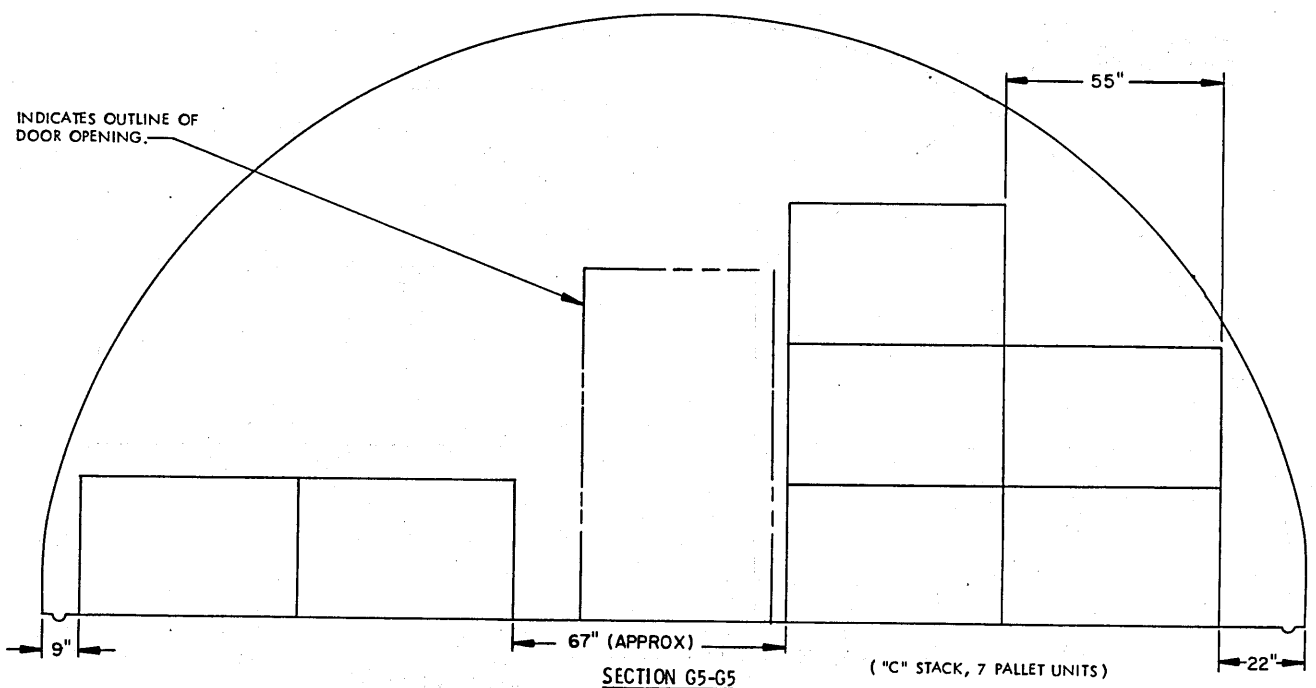

STORAGE PROCEDURES FOR UNIT NO. 48 (DECREASED-HEIGHT UNIT)

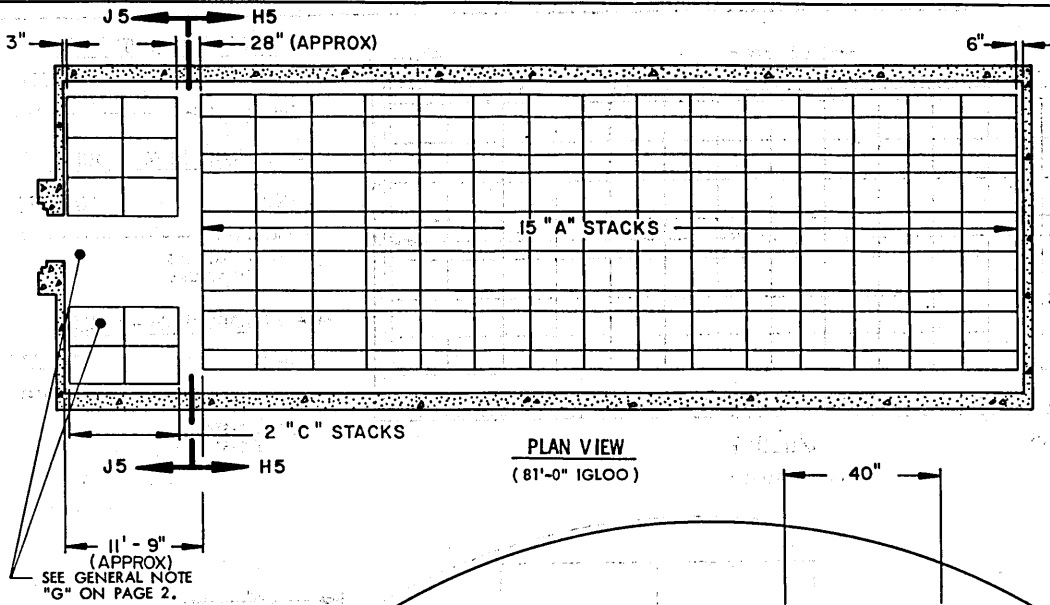

STORAGE IN 81'-0" IGLOO

ITEM	QUANTITY
PALLET UNITS	256

*** STORAGE IN 60'-8" IGLOO**

ITEM	QUANTITY
PALLET UNITS	184
10 A-STACKS	
3 C-STACKS	

**** STORAGE IN 40'-4" IGLOO**

ITEM	QUANTITY
PALLET UNITS	112
6 A-STACKS	
2 C-STACKS	

PLAN VIEW
(81'-0" IGLOO)

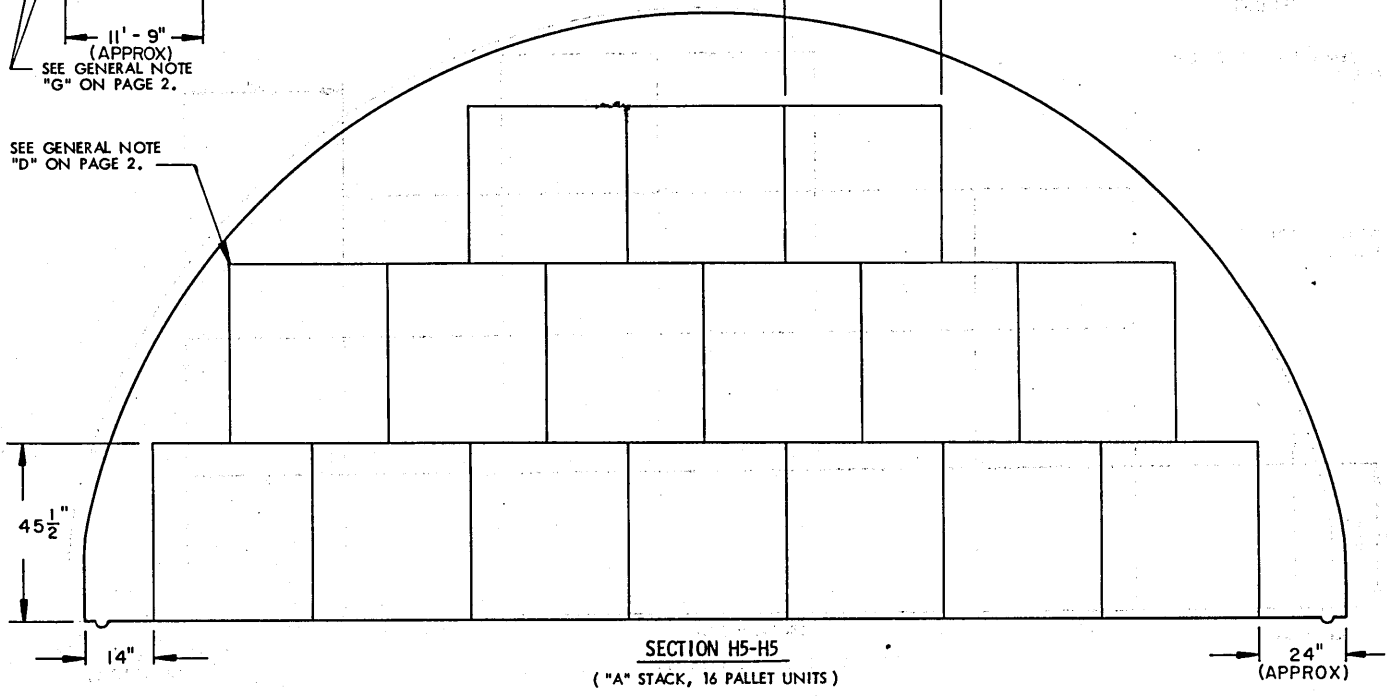

SECTION H5-H5
("A" STACK, 16 PALLET UNITS)

INDICATES OUTLINE OF DOOR OPENING.

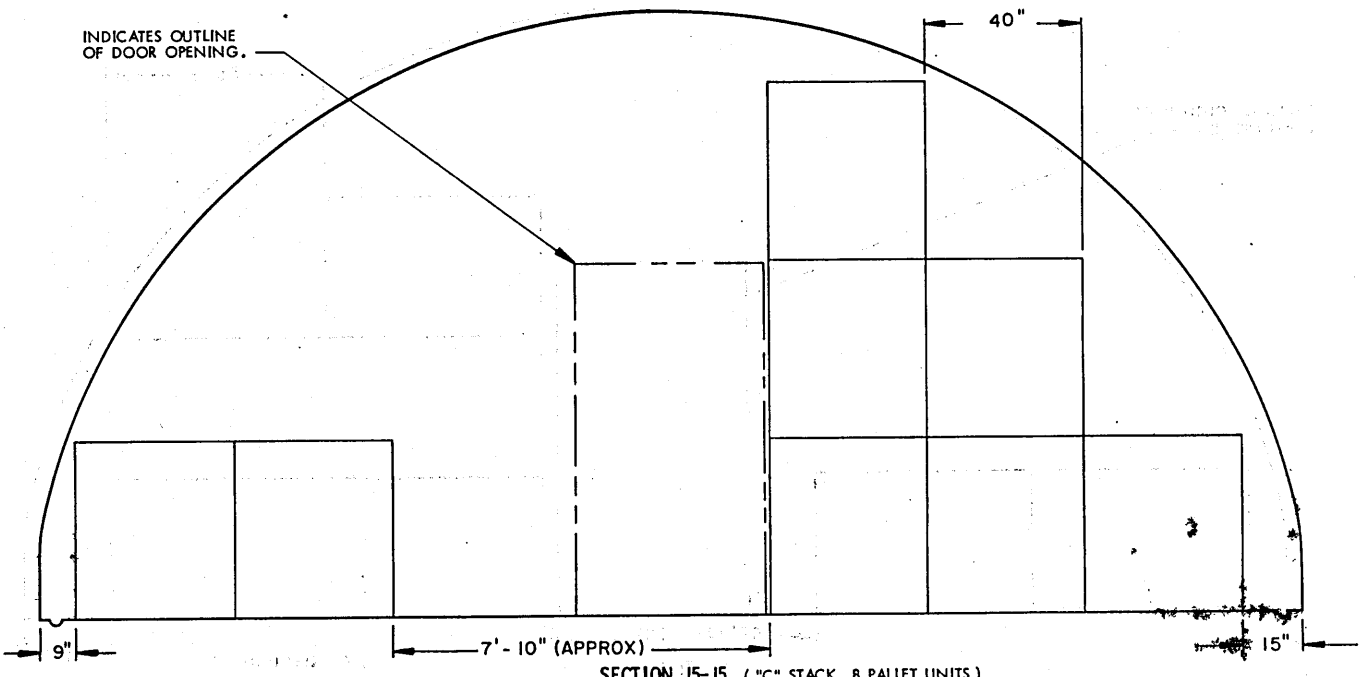

SECTION J5-J5 ("C" STACK, 8 PALLET UNITS)

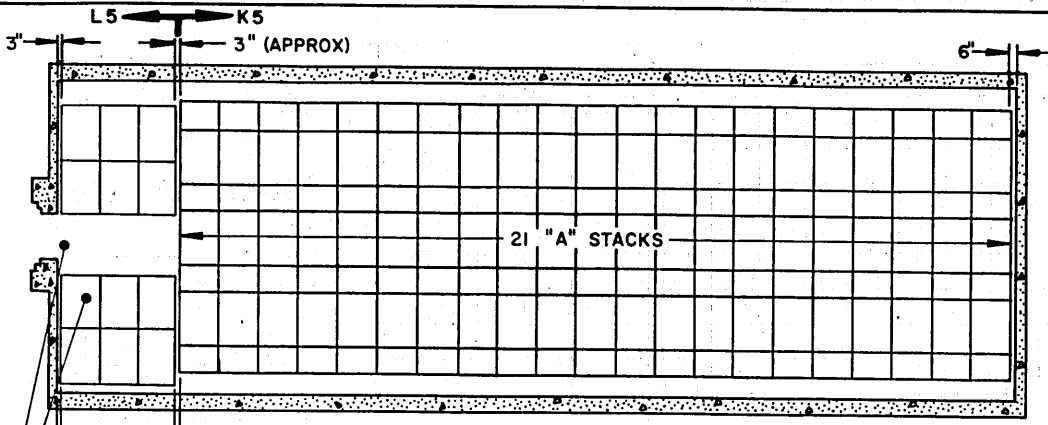

STORAGE IN 81'-0" IGLOO

ITEM	QUANTITY
PALLET UNITS	336

*** STORAGE IN 60'-8" IGLOO**

ITEM	QUANTITY
PALLET UNITS	231

- * 14 A-STACKS
- 3 C-STACKS

**** STORAGE IN 40'-4" IGLOO**

ITEM	QUANTITY
PALLET UNITS	141

- ** 8 A-STACKS
- 3 C-STACKS

PLAN VIEW
(81'-0" IGLOO)

SEE GENERAL NOTE "G" ON PAGE 2.

SEE GENERAL NOTE "D" ON PAGE 2.

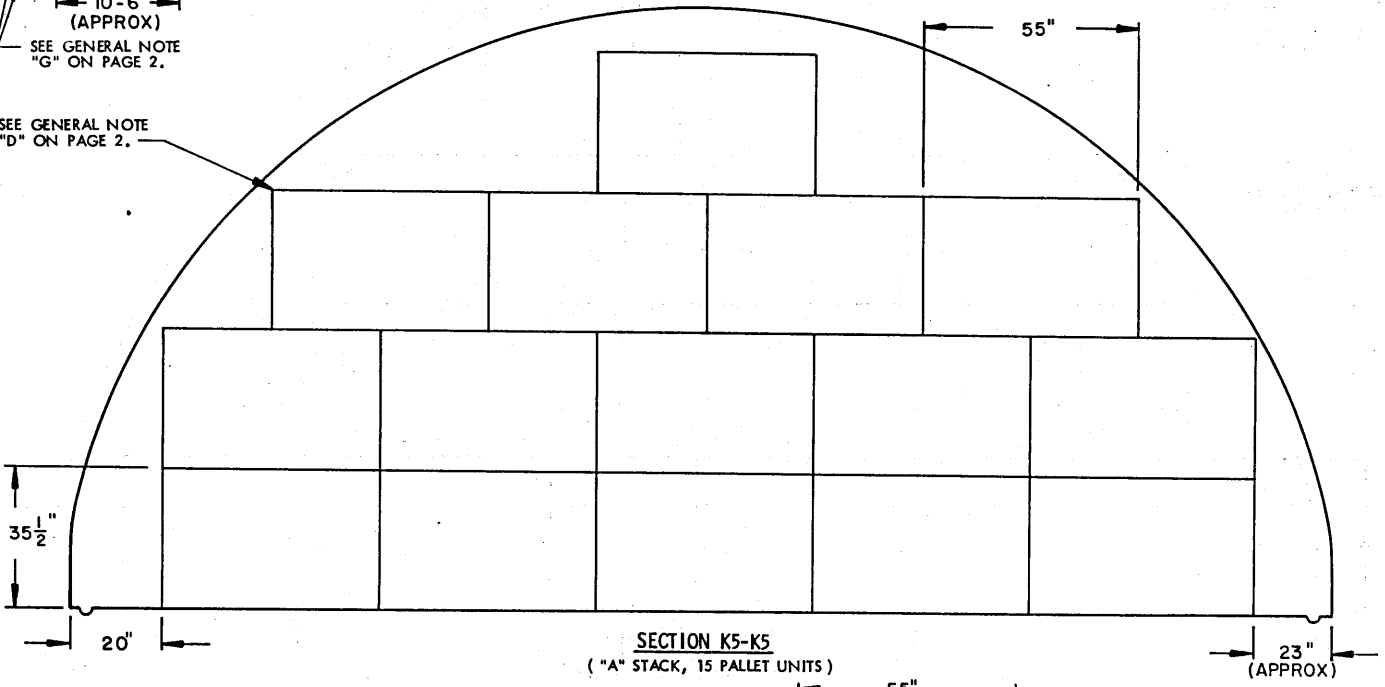

SECTION K5-K5
("A" STACK, 15 PALLET UNITS)

INDICATES OUTLINE OF DOOR OPENING.

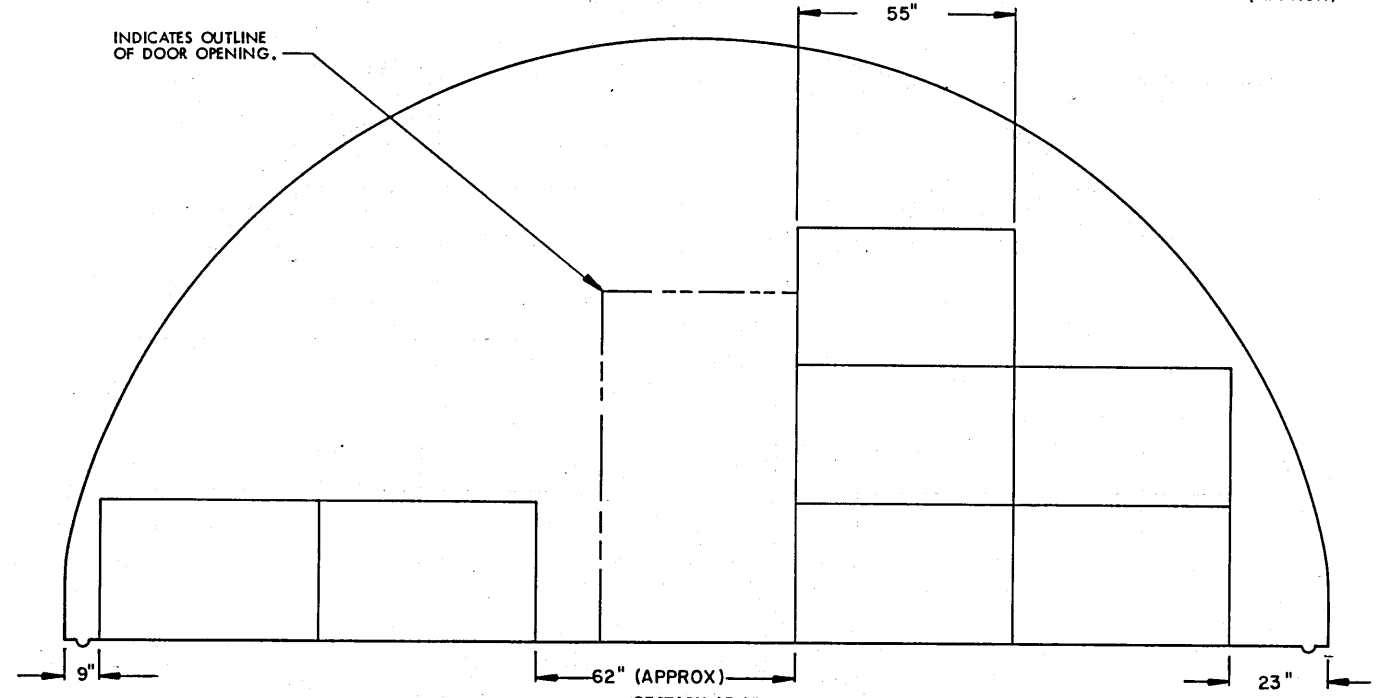

SECTION L5-L5 ("C" STACK, 7 PALLET UNITS)

STORAGE PROCEDURES FOR UNIT NO. 49 (DECREASED-HEIGHT UNIT)

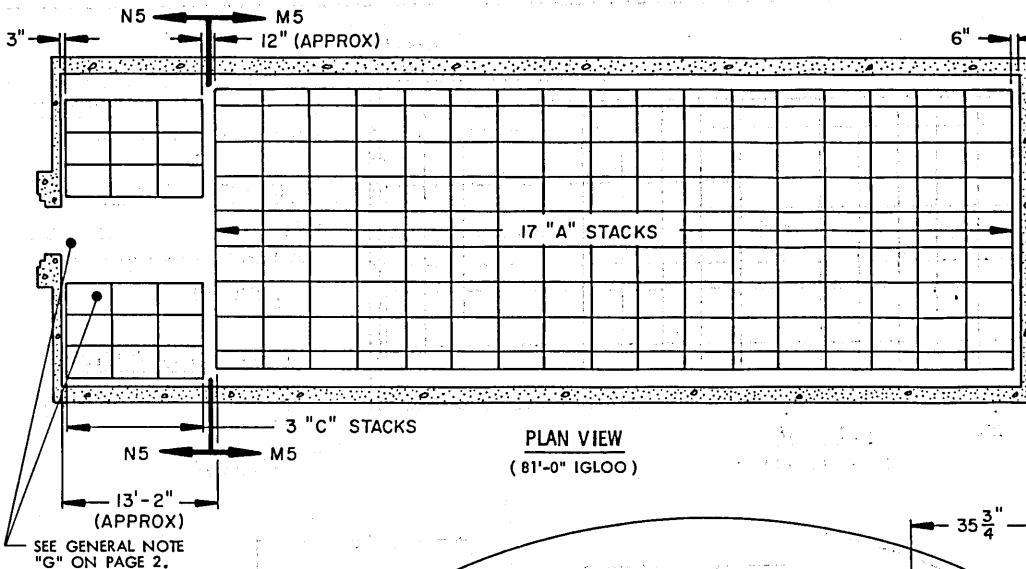

PLAN VIEW
(81'-0" IGLOO)

STORAGE IN 81'-0" IGLOO

ITEM	QUANTITY
PALLET UNITS	373

*** STORAGE IN 60'-8" IGLOO**

ITEM	QUANTITY
PALLET UNITS	273
* 12 A-STACKS	
3 C-STACKS	

*** STORAGE IN 40'-4" IGLOO**

ITEM	QUANTITY
PALLET UNITS	162
* 7 A-STACKS	
2 C-STACKS	

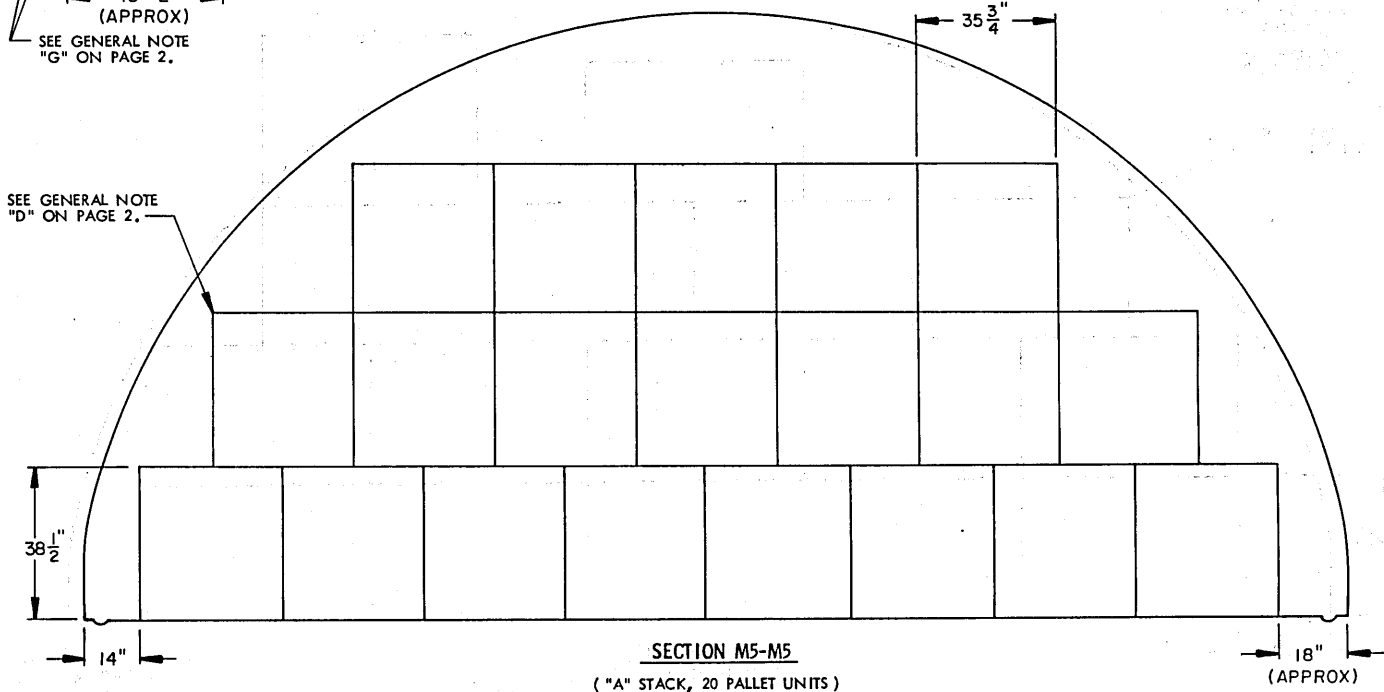

INDICATES OUTLINE OF DOOR OPENING.

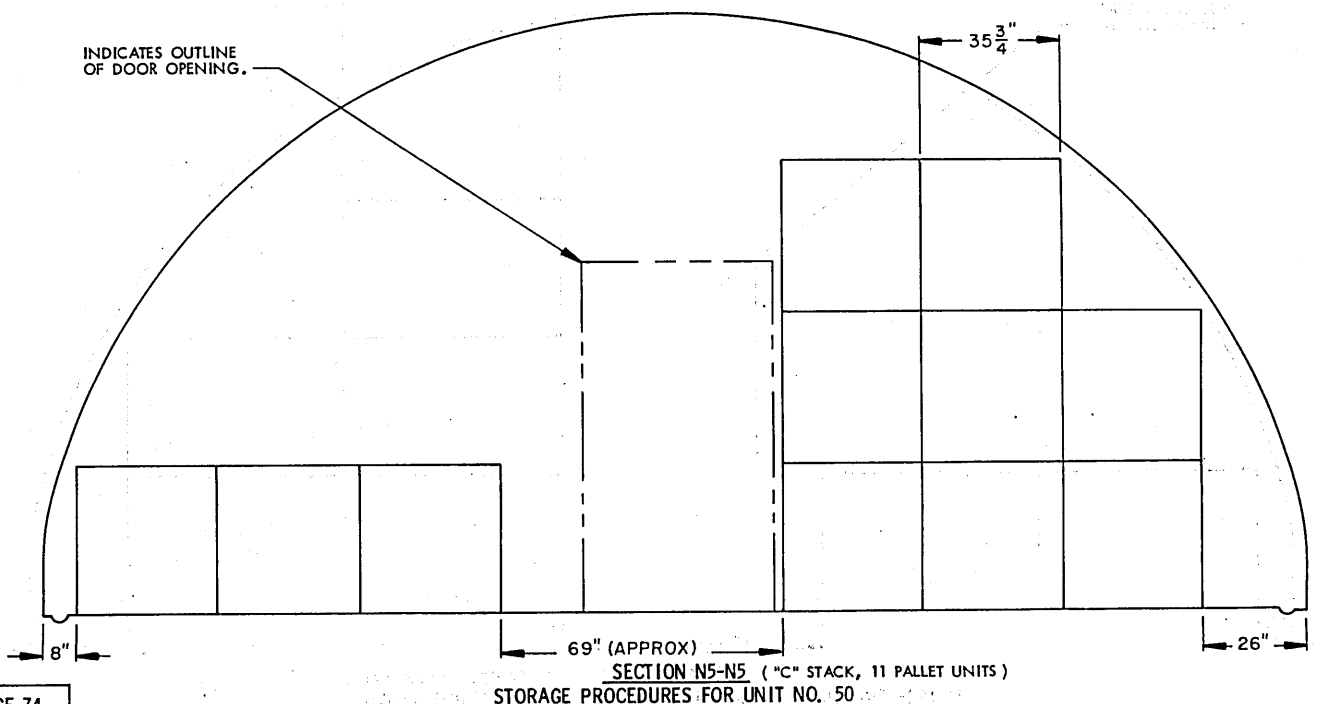

STORAGE PROCEDURES FOR UNIT NO. 50

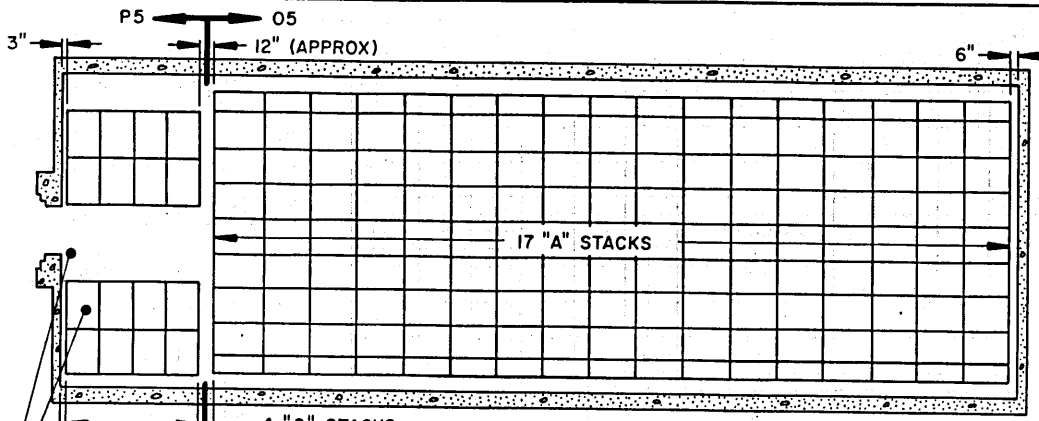

PLAN VIEW
(81'-0" IGLOO)

STORAGE IN 81'-0" IGLOO

ITEM	QUANTITY
PALLET UNITS	330

*** STORAGE IN 60'-8" IGLOO**

ITEM	QUANTITY
PALLET UNITS	240
12 A-STACKS	
4 C-STACKS	

**** STORAGE IN 40'-4" IGLOO**

ITEM	QUANTITY
PALLET UNITS	144
7 A-STACKS	
3 C-STACKS	

SEE GENERAL NOTE "G" ON PAGE 2.

SEE GENERAL NOTE "D" ON PAGE 2.

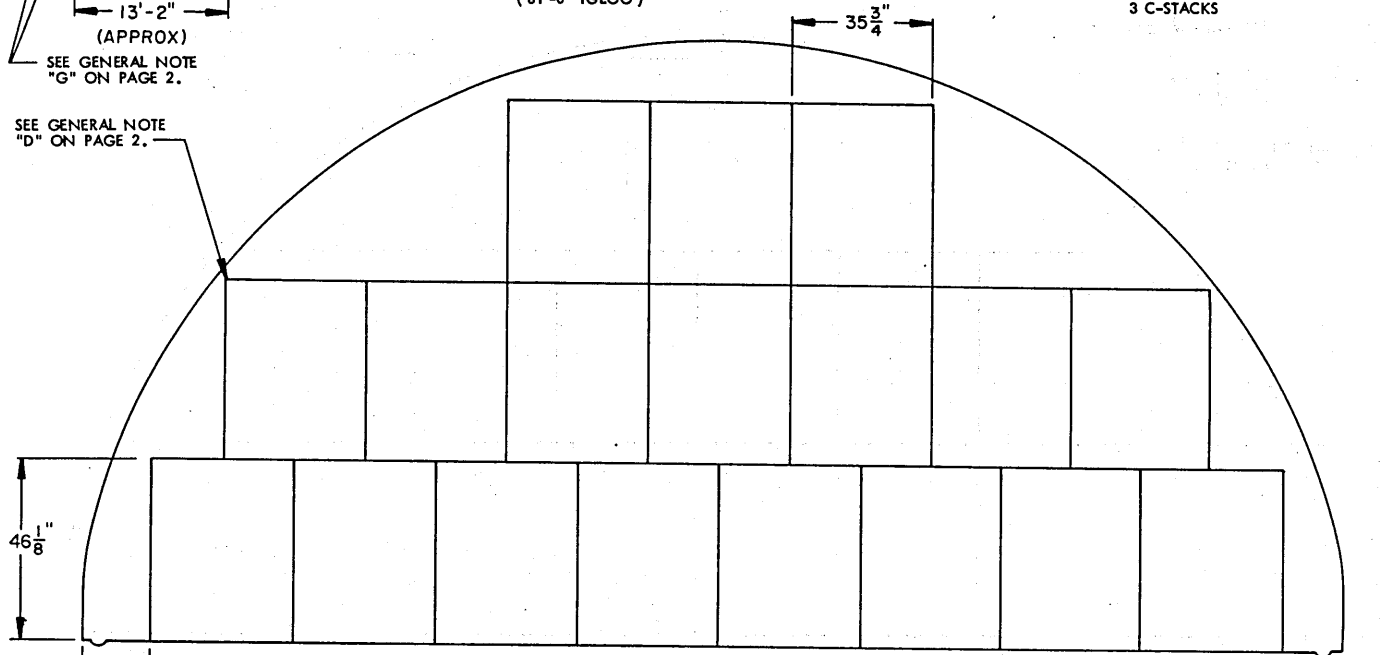

SECTION O5-O5
("A" STACK, 18 PALLET UNITS)

INDICATES OUTLINE OF DOOR OPENING.

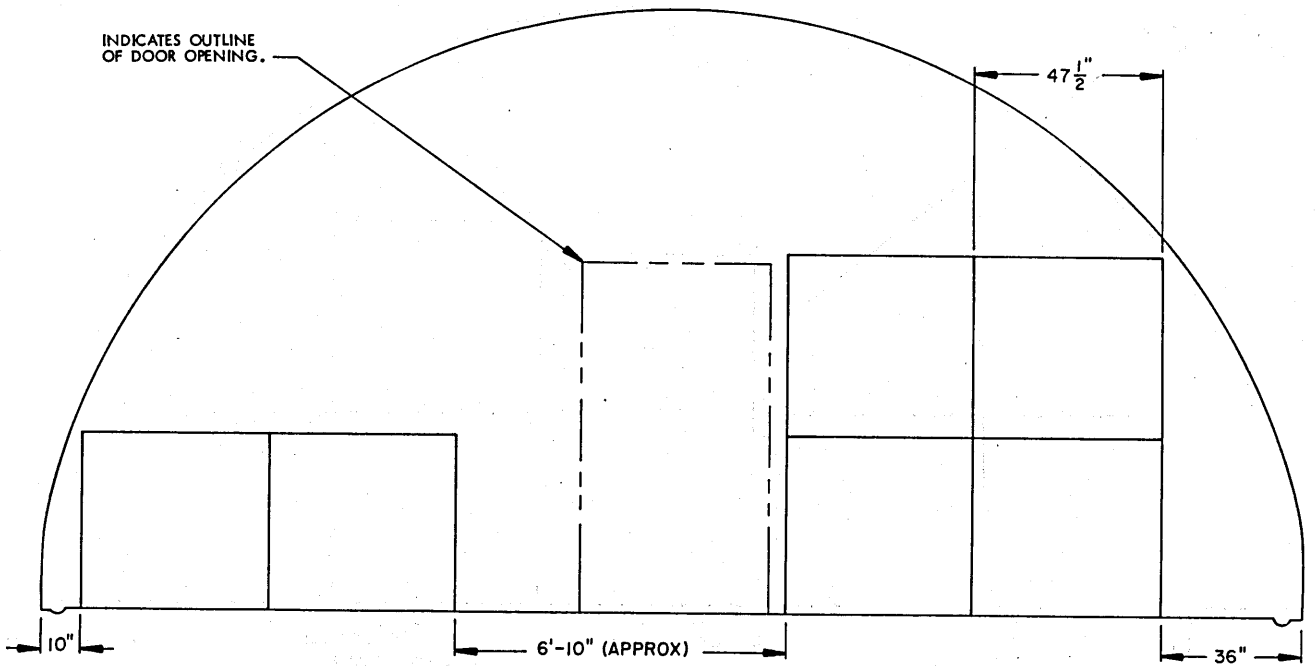

SECTION P5-P5 ("C" STACK, 6 PALLET UNITS)

STORAGE PROCEDURES FOR UNIT NO. 50 (INCREASED-HEIGHT UNIT)

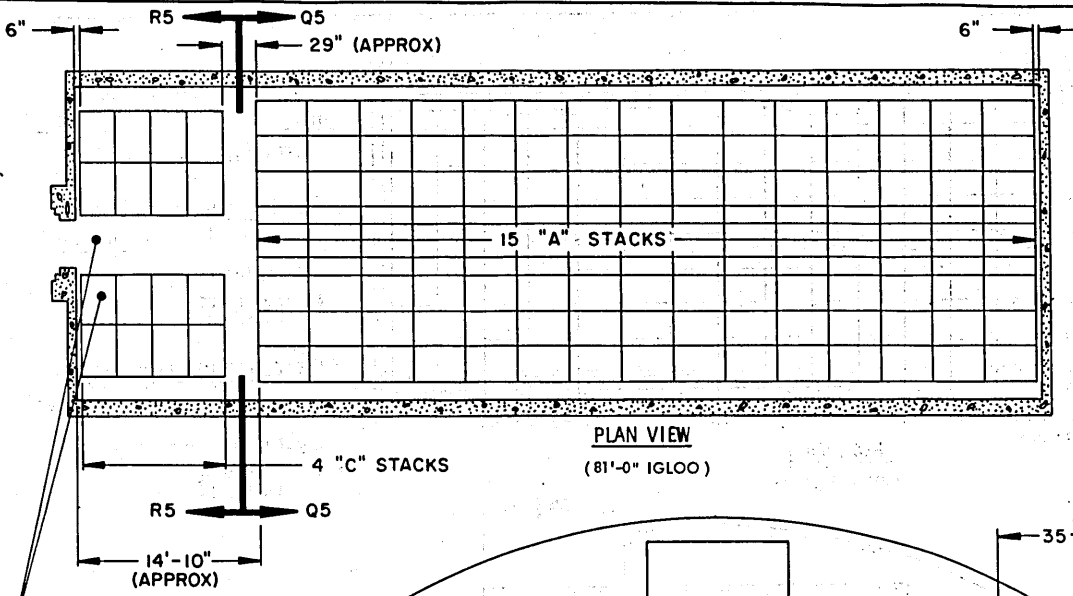

PLAN VIEW
(81'-0" IGLOO)

STORAGE IN 81'-0" IGLOO	
ITEM	QUANTITY
PALLET UNITS	245
* STORAGE IN 60'-8" IGLOO	
ITEM	QUANTITY
PALLET UNITS	180
* 11 "A" STACKS	
3 "C" STACKS	
** STORAGE IN 40'-4" IGLOO	
ITEM	QUANTITY
PALLET UNITS	110
** 6 "A" STACKS	
4 "C" STACKS	

SEE GENERAL NOTE "G" ON PAGE 2.

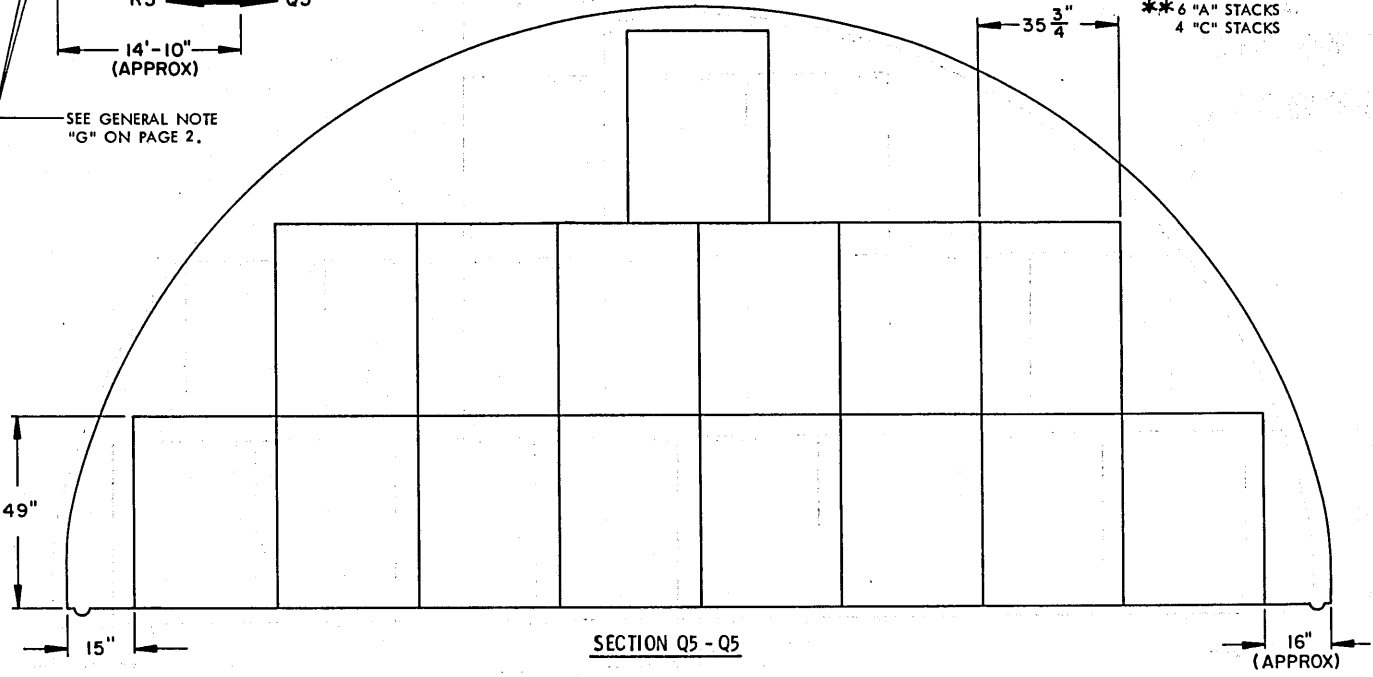

SECTION Q5 - Q5
("A" STACK, 15 PALLET UNITS)

INDICATES OUTLINE OF DOOR OPENING.

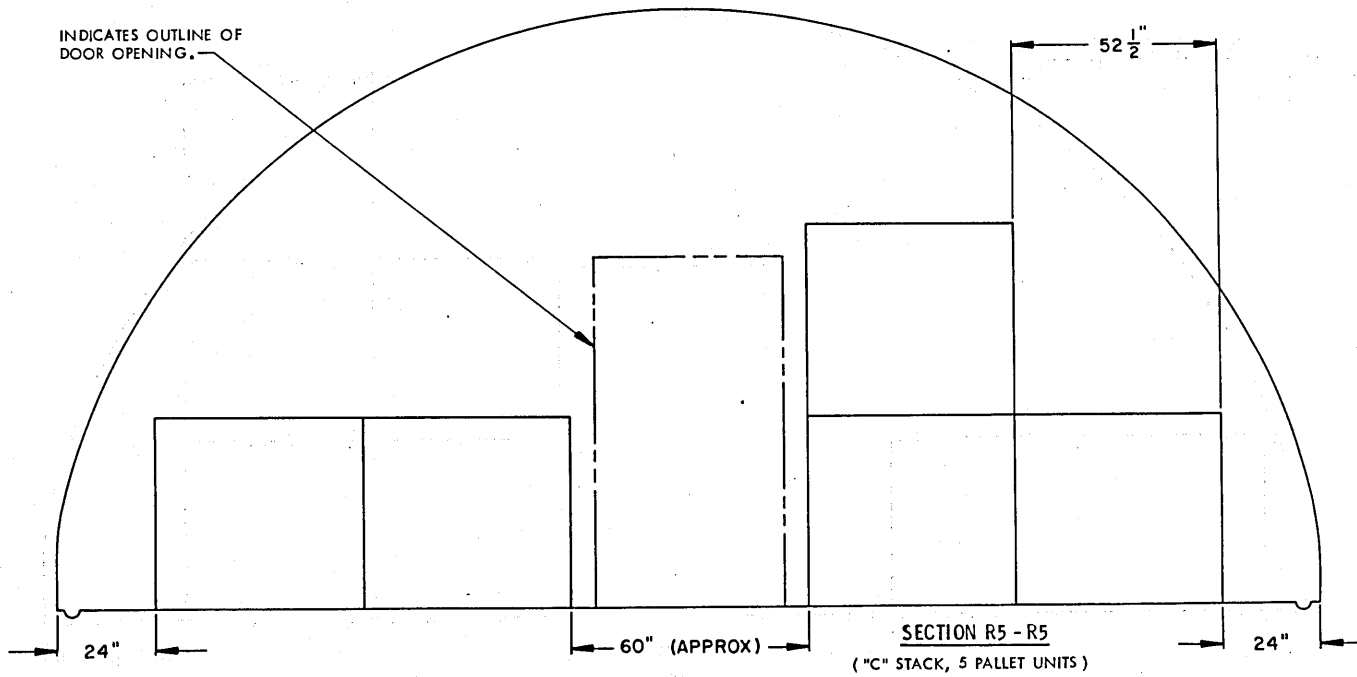

SECTION R5 - R5
("C" STACK, 5 PALLET UNITS)

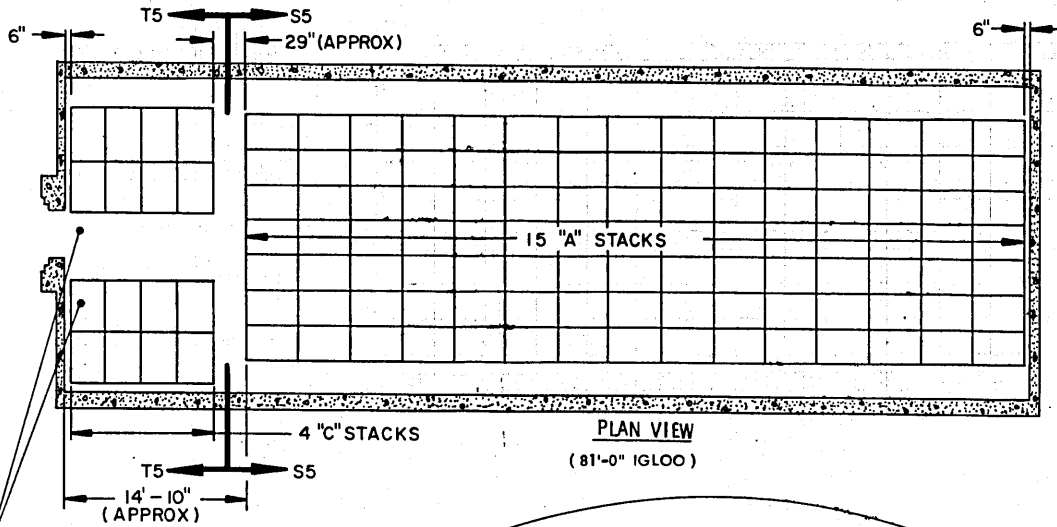

PLAN VIEW
(81'-0" IGLOO)

STORAGE IN 81'-0" IGLOO	
ITEM	QUANTITY
PALLET UNITS	313
* STORAGE IN 60'-8" IGLOO	
ITEM	QUANTITY
PALLET UNITS	230
* 11 "A" STACKS	
3 "C" STACKS	
** STORAGE IN 40'-4" IGLOO	
ITEM	QUANTITY
PALLET UNITS	142
* 6 A-STACKS	
4 C-STACKS	

SEE GENERAL NOTE "G" ON PAGE 2.

SEE GENERAL NOTE "D" ON PAGE 2.

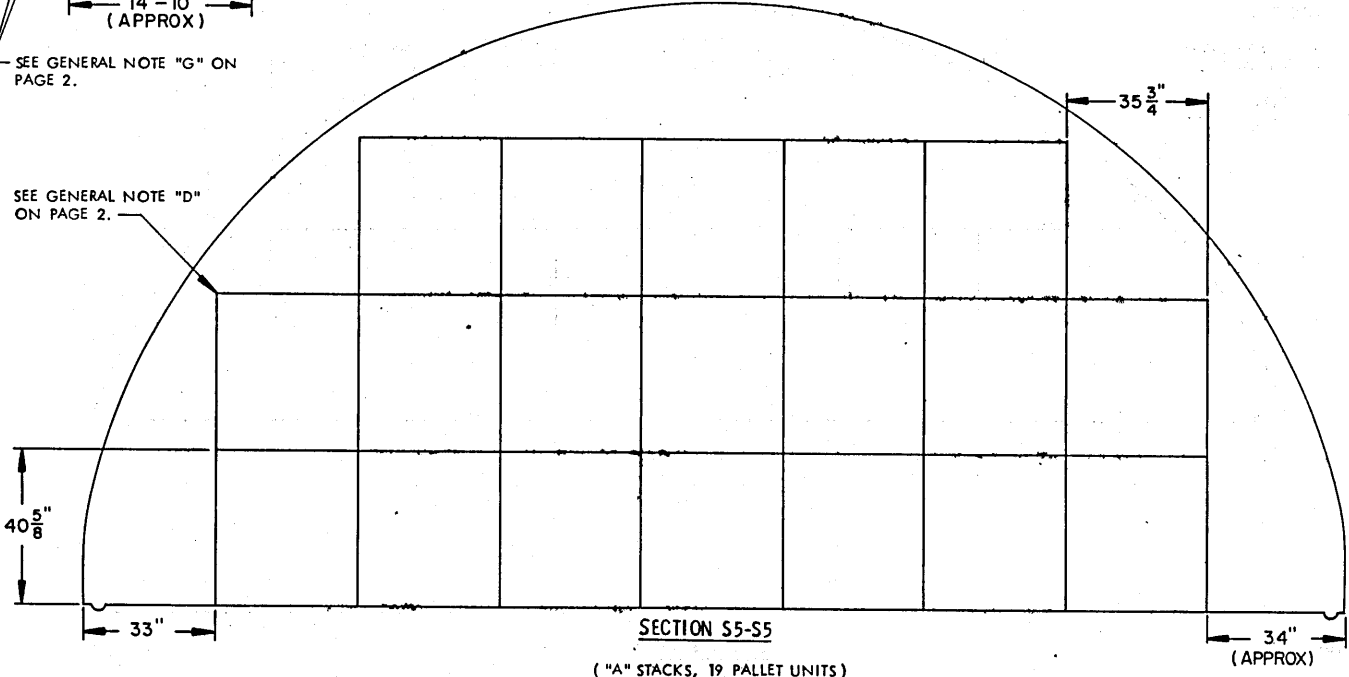

SECTION S5-S5
("A" STACKS, 19 PALLET UNITS)

INDICATES OUTLINE OF DOOR OPENING.

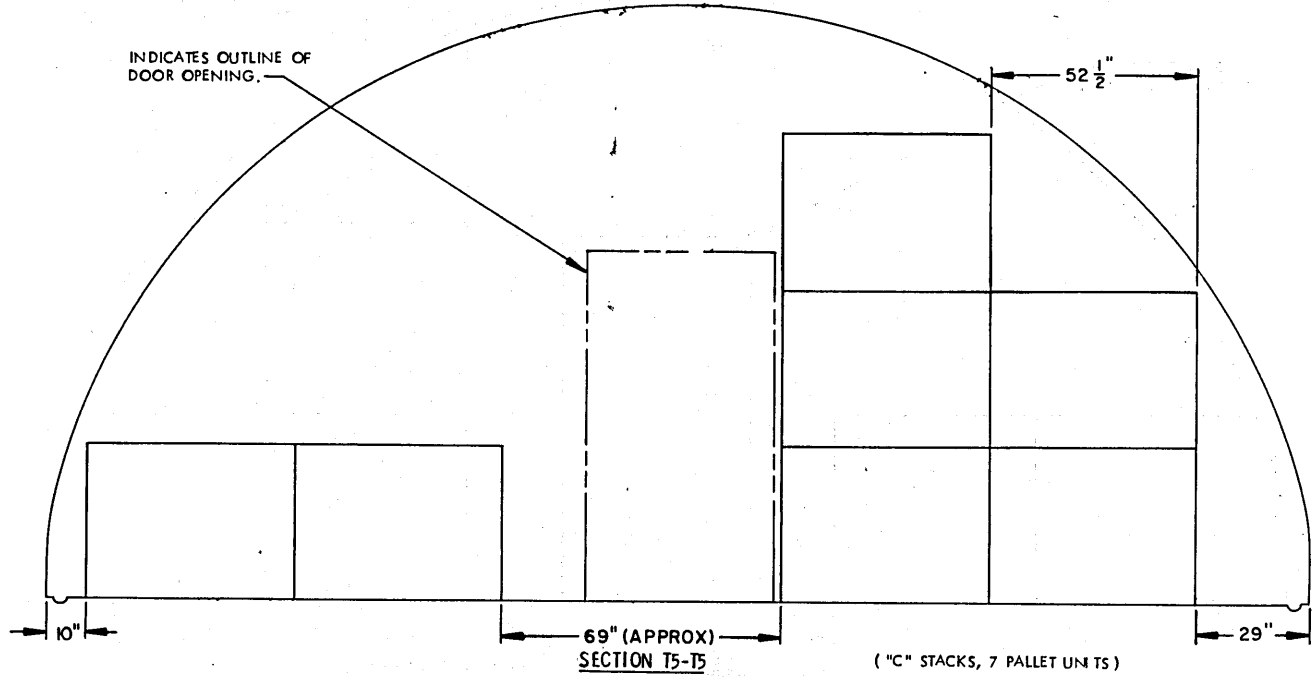

SECTION T5-T5
("C" STACKS, 7 PALLET UNITS)

STORAGE PROCEDURES FOR UNIT NO. 51 (DECREASED-HEIGHT UNIT)

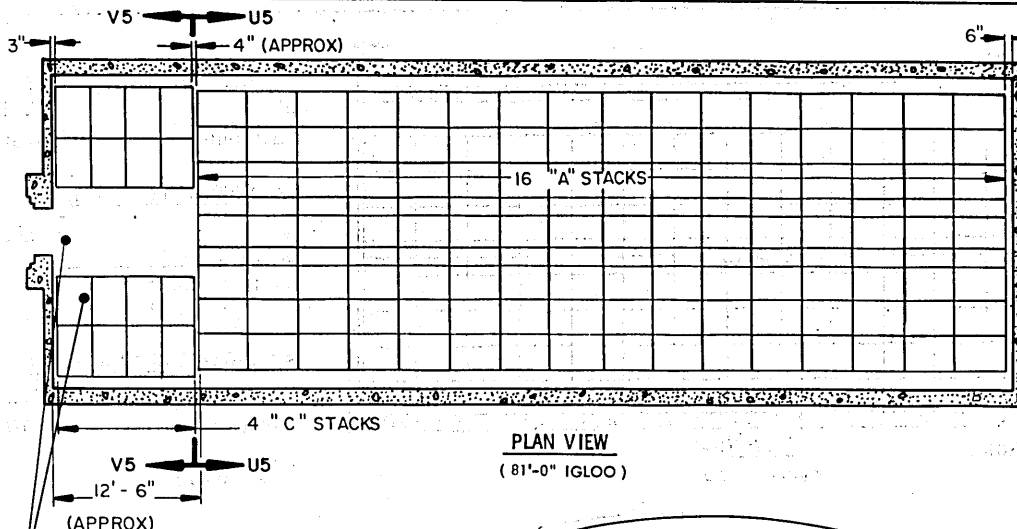

PLAN VIEW
(81'-0" IGLOO)

STORAGE IN 81'-0" IGLOO	
ITEM	QUANTITY
PALLET UNITS	260
* STORAGE IN 60'-8" IGLOO	
ITEM	QUANTITY
PALLET UNITS	185
* 11 A-STACKS	
4 C-STACKS	
** STORAGE IN 40'-4" IGLOO	
ITEM	QUANTITY
PALLET UNITS	110
** 6 A-STACKS	
4 C-STACKS	

SEE GENERAL NOTE "G" ON PAGE 2.

SEE GENERAL NOTE "D" ON PAGE 2.

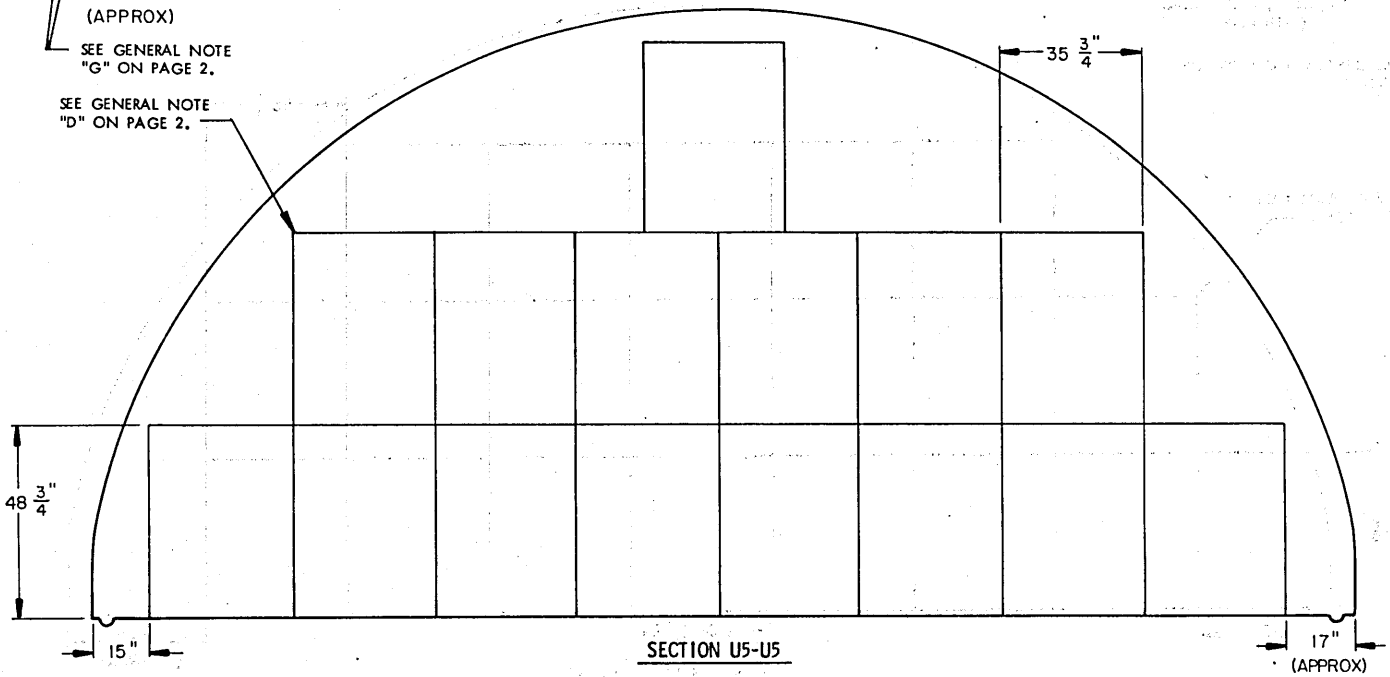

SECTION U5-U5
("A" STACK, 15 PALLET UNITS)

INDICATES OUTLINE OF DOOR OPENING.

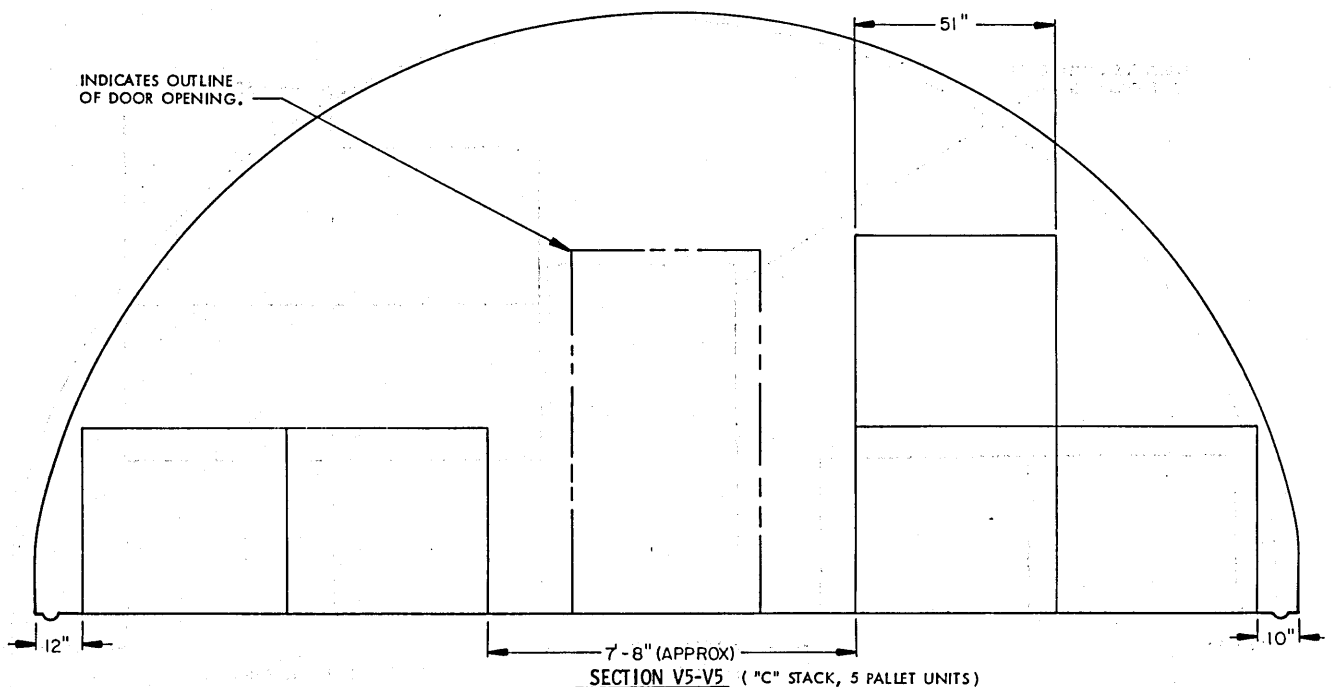

SECTION V5-V5 ("C" STACK, 5 PALLET UNITS)

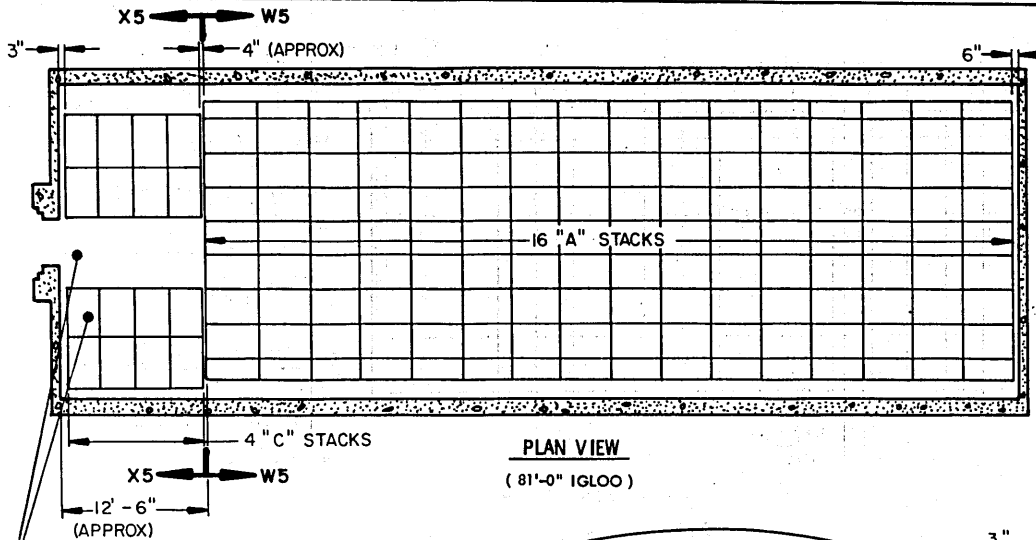

PLAN VIEW
(81'-0" IGLOO)

STORAGE IN 81'-0" IGLOO	
ITEM	QUANTITY
PALLET UNITS	348
* STORAGE IN 60'-8" IGLOO	
ITEM	QUANTITY
PALLET UNITS	248
11 A-STACKS	
4 C-STACKS	
** STORAGE IN 40'-4" IGLOO	
ITEM	QUANTITY
PALLET UNITS	148
6 A-STACKS	
4 C-STACKS	

SEE GENERAL NOTE "G" ON PAGE 2.

SEE GENERAL NOTE "D" ON PAGE 2.

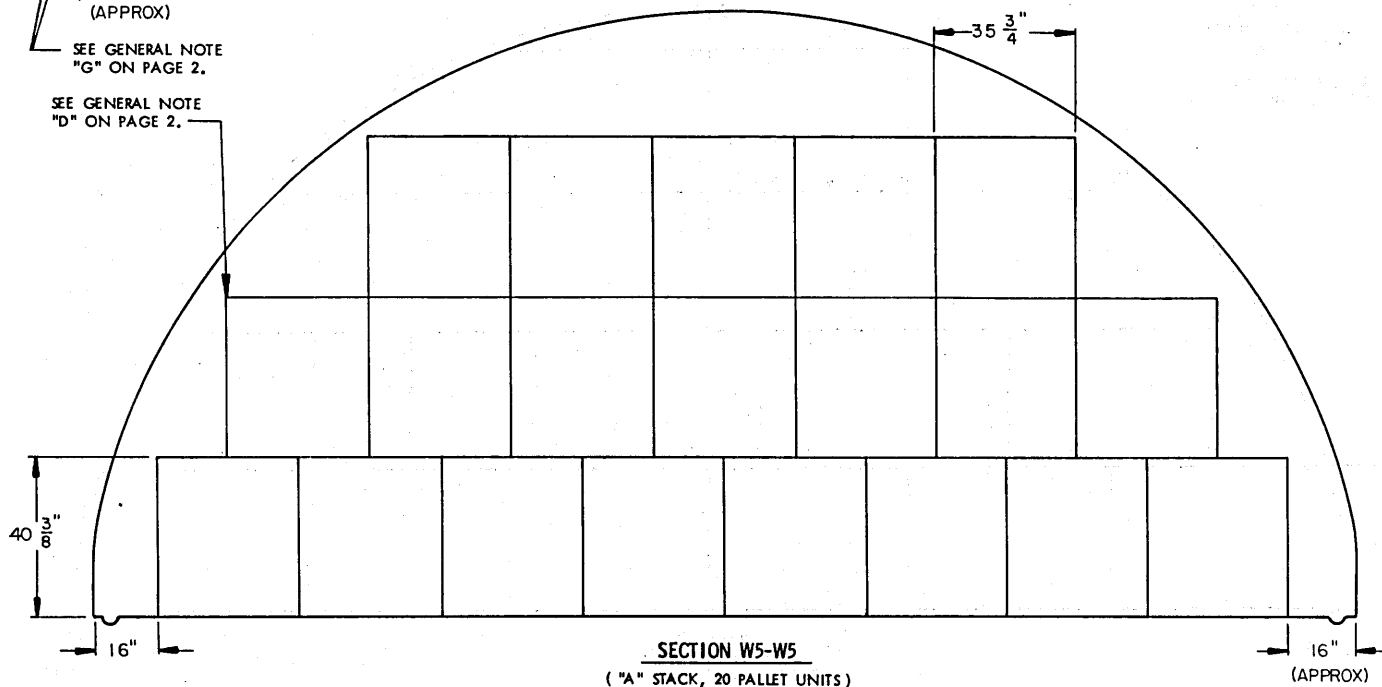

SECTION W5-W5
("A" STACK, 20 PALLET UNITS)

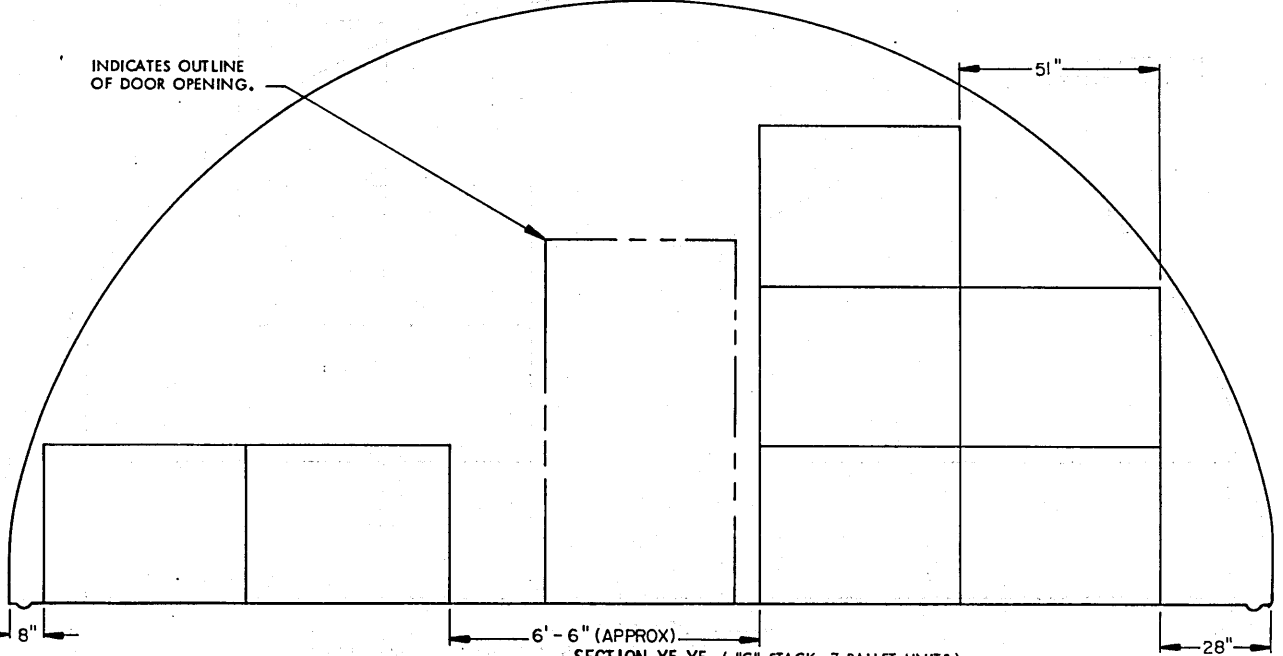

SECTION X5-X5 ("C" STACK, 7 PALLET UNITS)

STORAGE PROCEDURES FOR UNIT NO. 52 (DECREASED-HEIGHT UNIT)

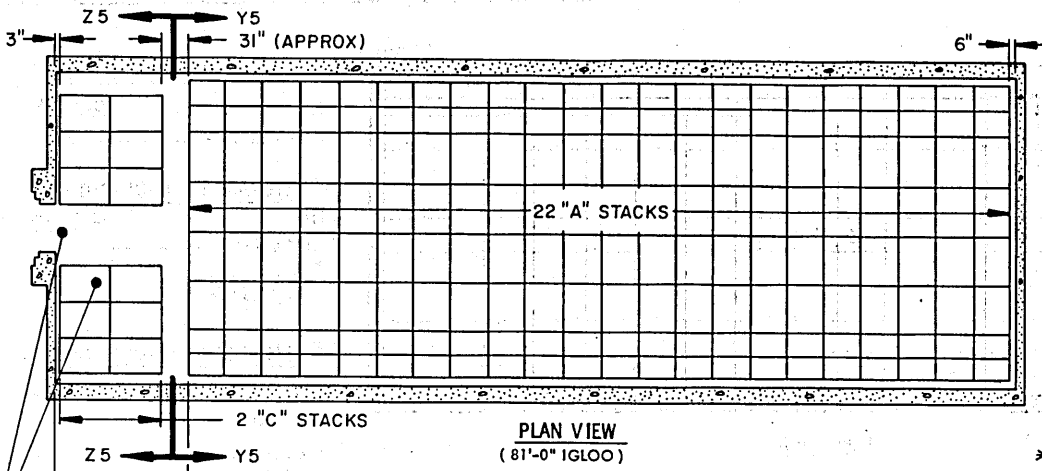

STORAGE IN 81'-0" IGLOO	
ITEM	QUANTITY
PALLET UNITS	396
* STORAGE IN 60'-8" IGLOO	
ITEM	QUANTITY
PALLET UNITS	288
* 15 A-STACKS	
3 C-STACKS	
** STORAGE IN 40'-4" IGLOO	
ITEM	QUANTITY
PALLET UNITS	175
* * 9 A-STACKS	
2 C-STACKS	

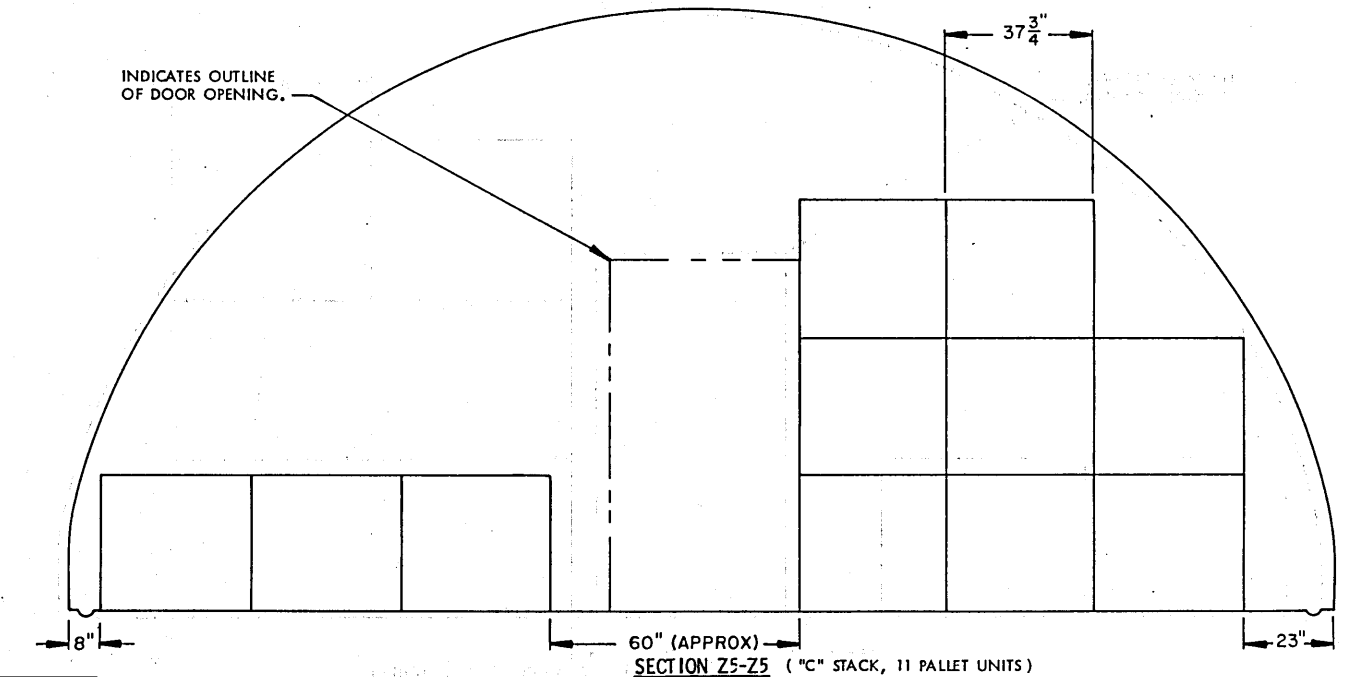
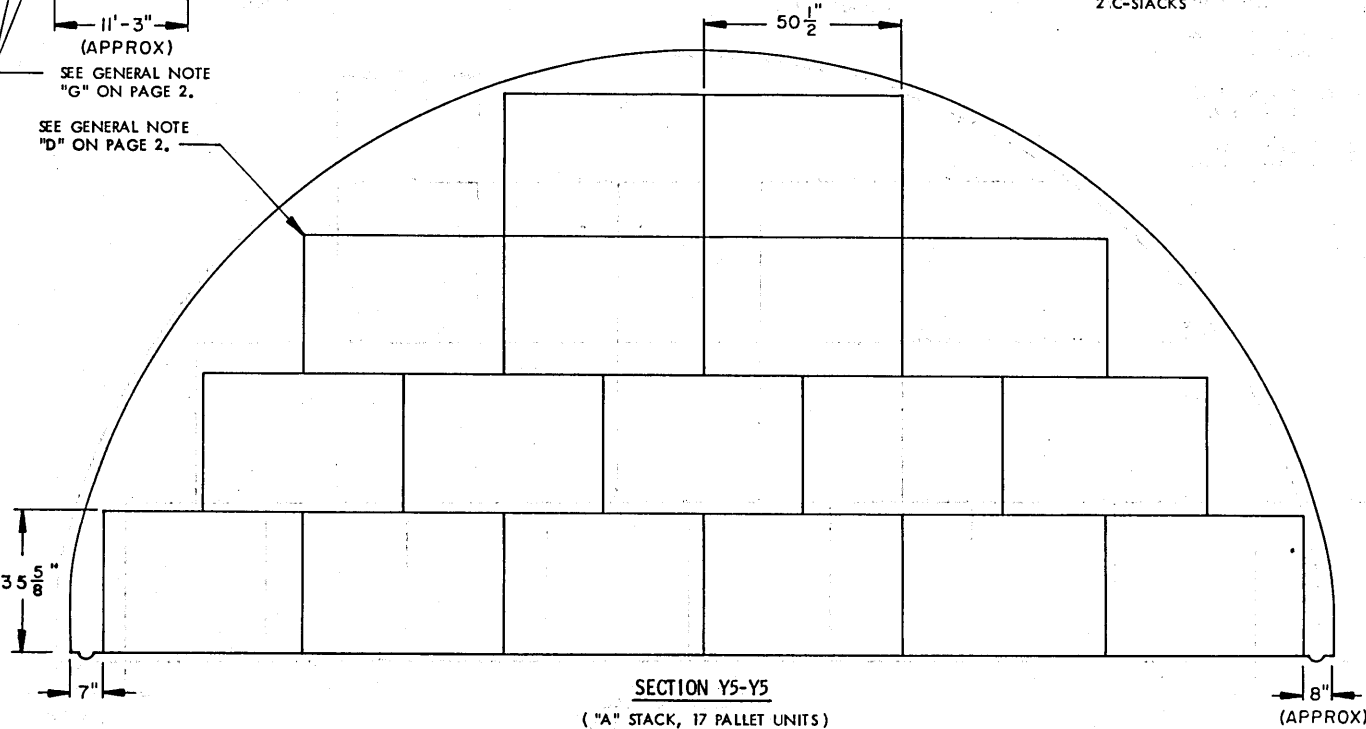

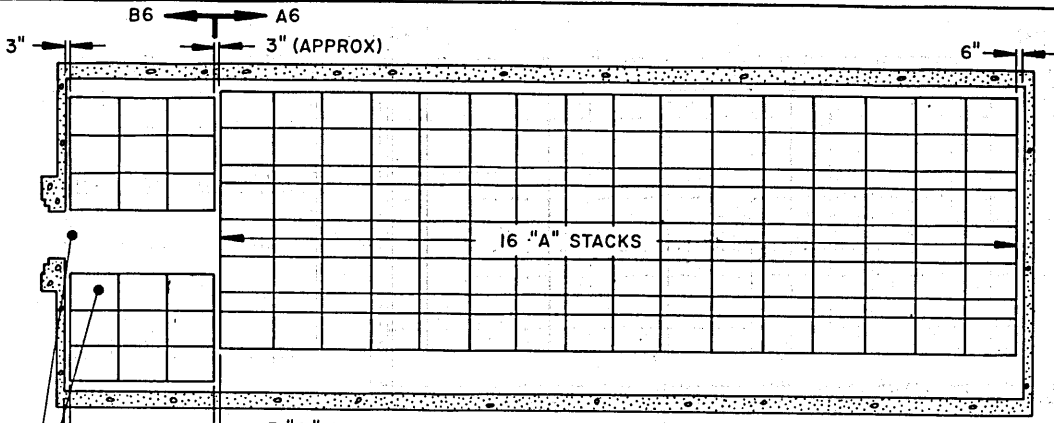

PLAN VIEW
(81'-0" IGLOO)

STORAGE IN 81'-0" IGLOO

ITEM	QUANTITY
PALLET UNITS	283

*** STORAGE IN 60'-8" IGLOO**

ITEM	QUANTITY
PALLET UNITS	203

- * 11 A-STACKS
- 3 C-STACKS

**** STORAGE IN 40'-4" IGLOO**

ITEM	QUANTITY
PALLET UNITS	162

- ** 9 A-STACKS
- 2 C-STACKS

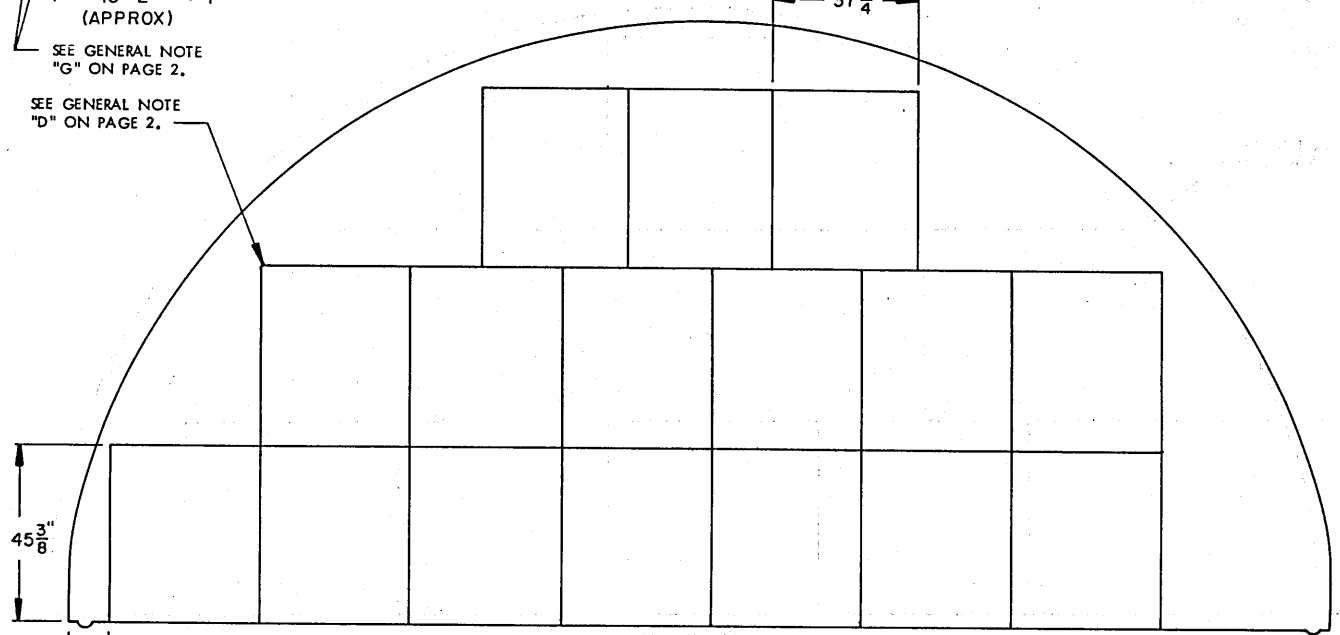

SECTION A6-A6
("A" STACK, 16 PALLET UNITS)

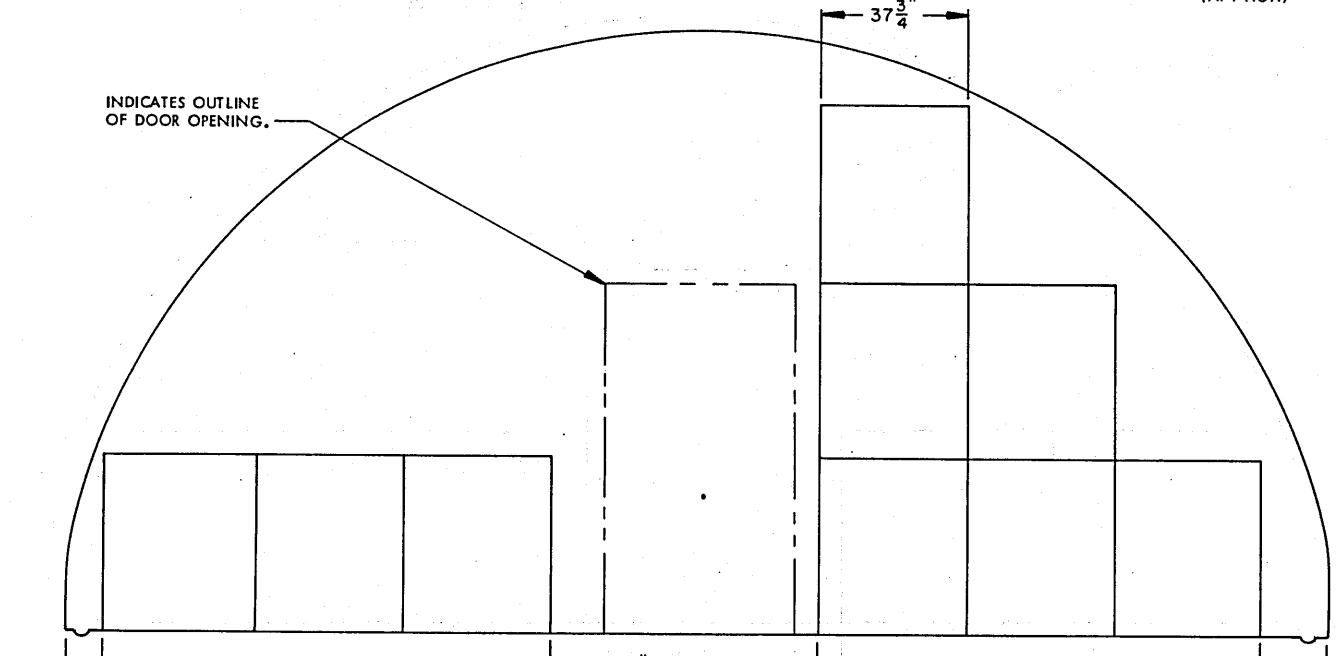

SECTION B6-B6 ("C" STACK, 9 PALLET UNITS)

STORAGE PROCEDURES FOR UNIT NO. 53 (INCREASED-HEIGHT UNIT)

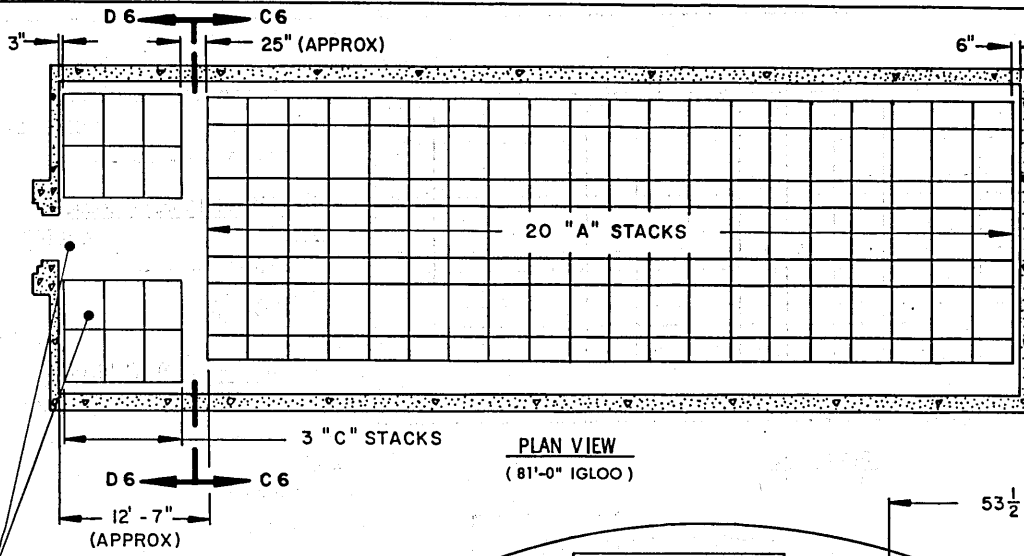

STORAGE IN 81'-0" IGLOO	
ITEM	QUANTITY
PALLET UNITS	215
* STORAGE IN 60'-8" IGLOO	
ITEM	QUANTITY
PALLET UNITS	155
* 14 A-STACKS	
3 C-STACKS	
** STORAGE IN 40'-4" IGLOO	
ITEM	QUANTITY
PALLET UNITS	95
** 8 A-STACKS	
3 C-STACKS	

SEE GENERAL NOTE "G" ON PAGE 2.

SEE GENERAL NOTE "D" ON PAGE 2.

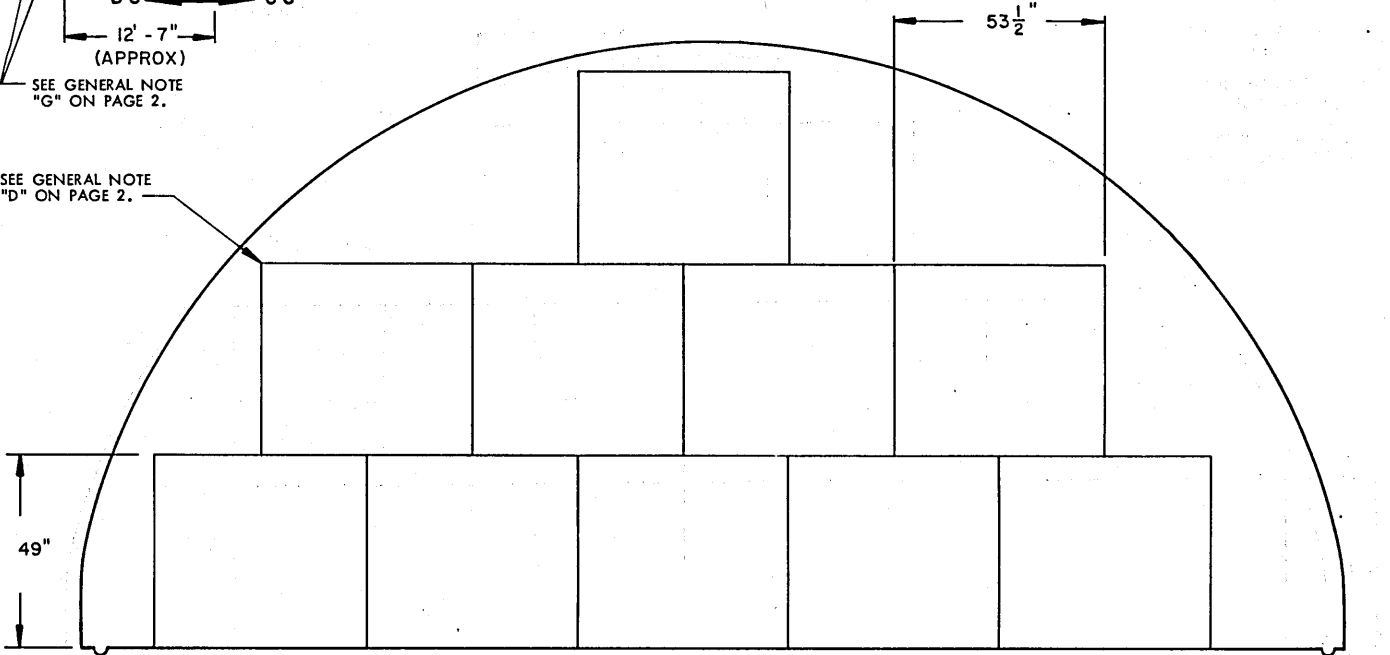

SECTION C6-C6
(*A" STACK, 10 PALLET UNITS)

INDICATES OUTLINE OF DOOR OPENING.

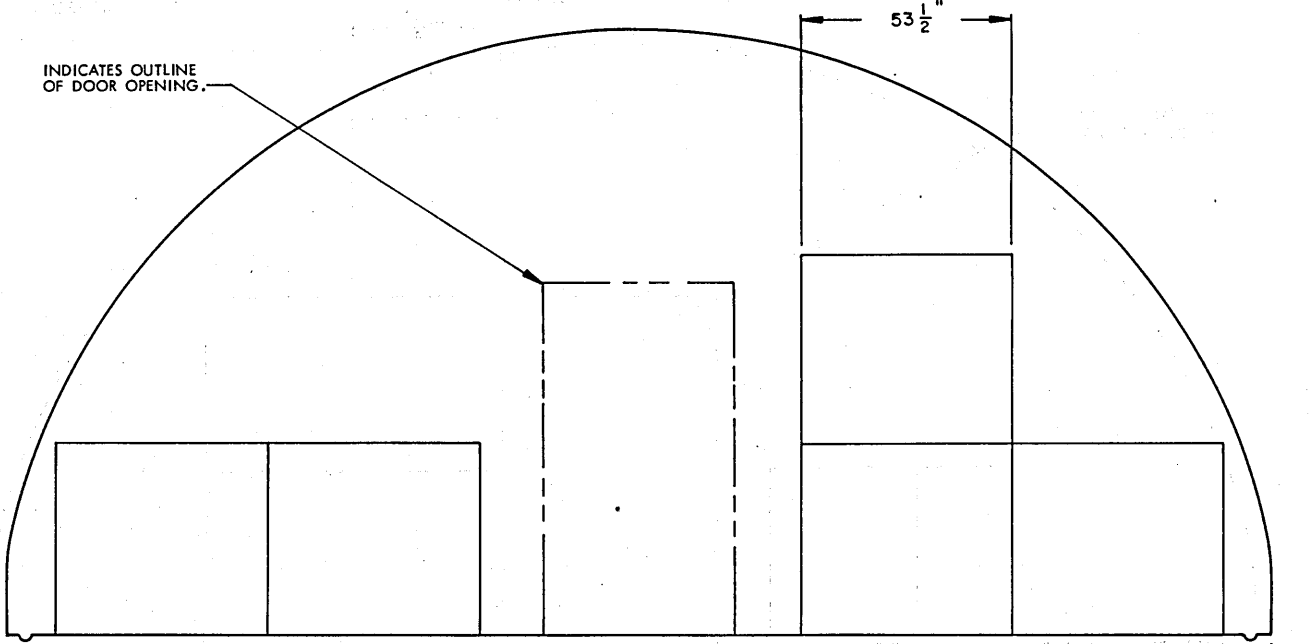

SECTION D6-D6 (*C" STACK, 5 PALLET UNITS)
STORAGE PROCEDURES FOR UNIT NO. 54

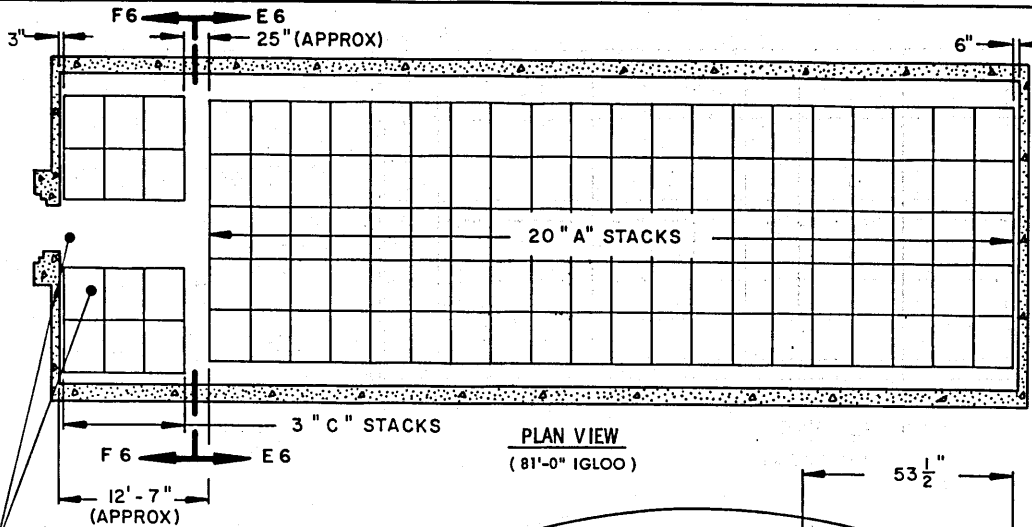

STORAGE IN 81'-0" IGLOO	
ITEM	QUANTITY
PALLET UNITS	281
* STORAGE IN 60'-8" IGLOO	
ITEM	QUANTITY
PALLET UNITS	203
* 14 A-STACKS	
3 C-STACKS	
** STORAGE IN 40'-4" IGLOO	
ITEM	QUANTITY
PALLET UNITS	125
** 8 A-STACKS	
3 C-STACKS	

PLAN VIEW
(81'-0" IGLOO)

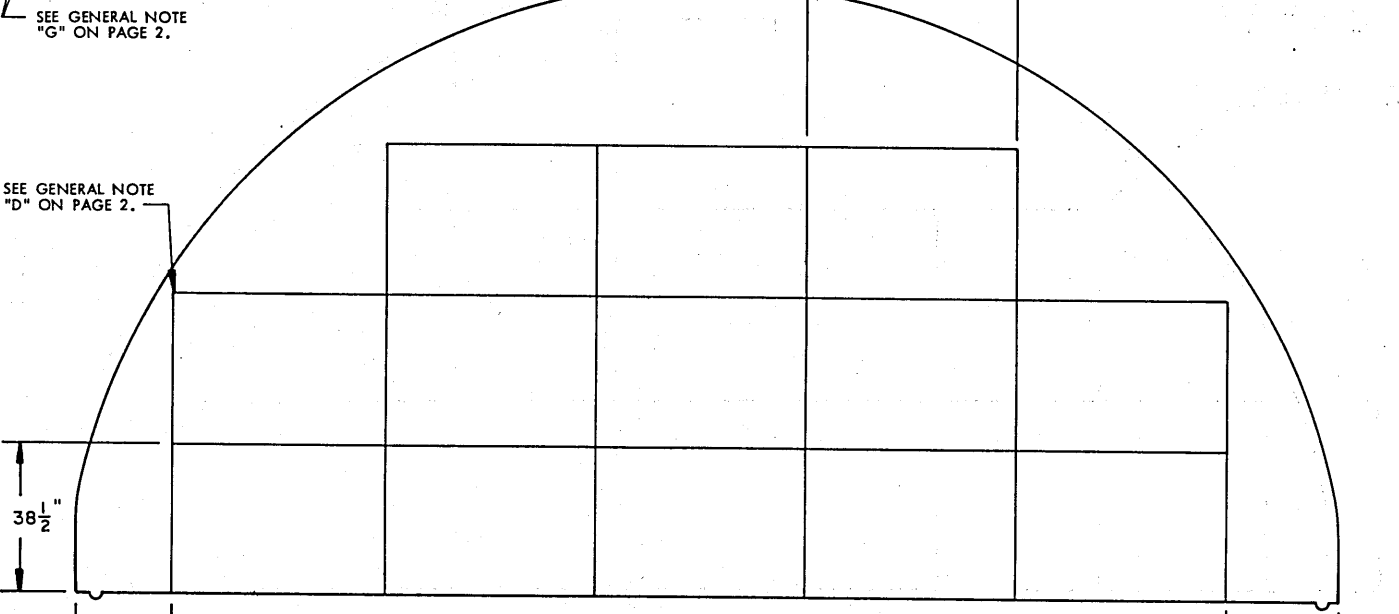

SECTION E6-E6
("A" STACK, 13 PALLET UNITS)

INDICATES OUTLINE OF DOOR OPENING.

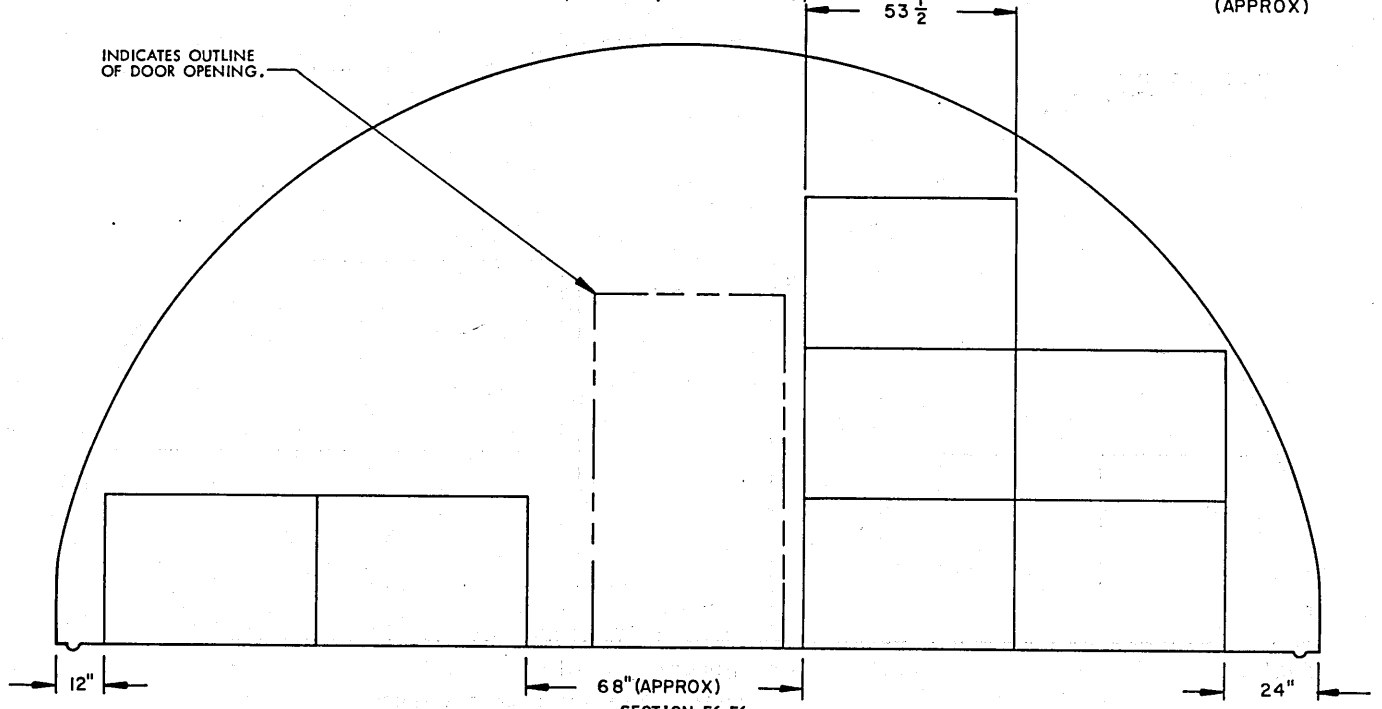

SECTION F6-F6 ("C" STACK, 7 PALLET UNITS)

STORAGE PROCEDURES FOR UNIT NO. 54 (DECREASED-HEIGHT UNIT)

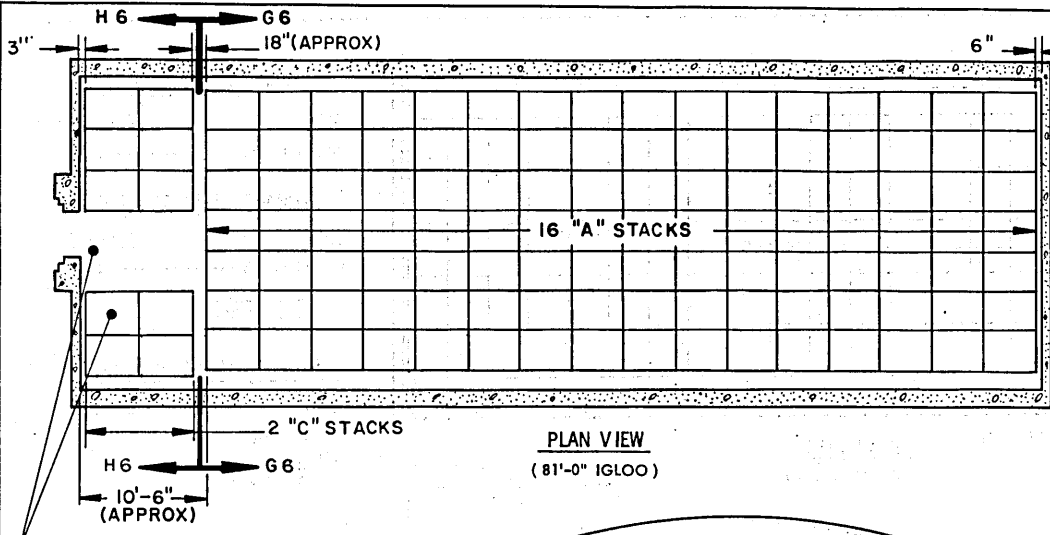

PLAN VIEW
(81'-0" IGLOO)

STORAGE IN 81'-0" IGLOO	
ITEM	QUANTITY
PALLET UNITS	222
* STORAGE IN 60'-8" IGLOO	
ITEM	QUANTITY
PALLET UNITS	157
* 11 A-STACKS	
2 C-STACKS	
** STORAGE IN 40'-4" IGLOO	
ITEM	QUANTITY
PALLET UNITS	92
** 6 A-STACKS	
2 C-STACKS	

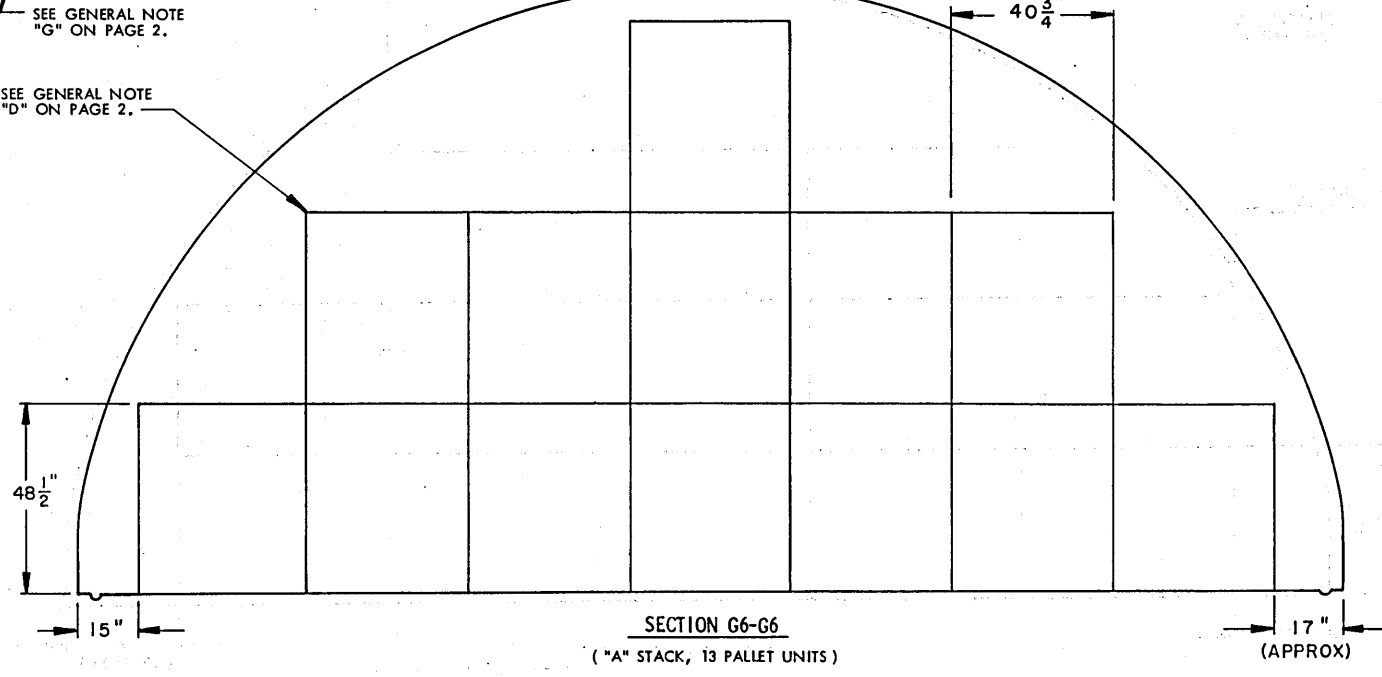

SECTION G6-G6
("A" STACK, 13 PALLET UNITS)

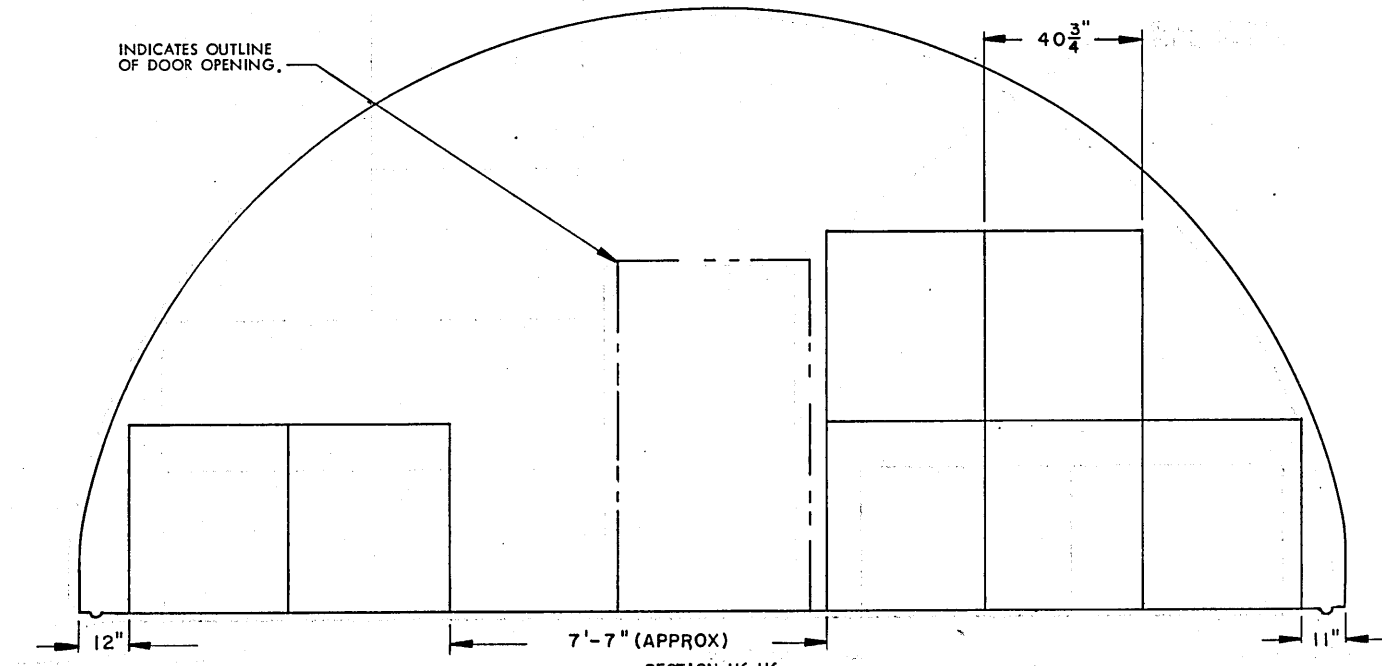

SECTION H6-H6 ("C" STACK, 7 PALLET UNITS)

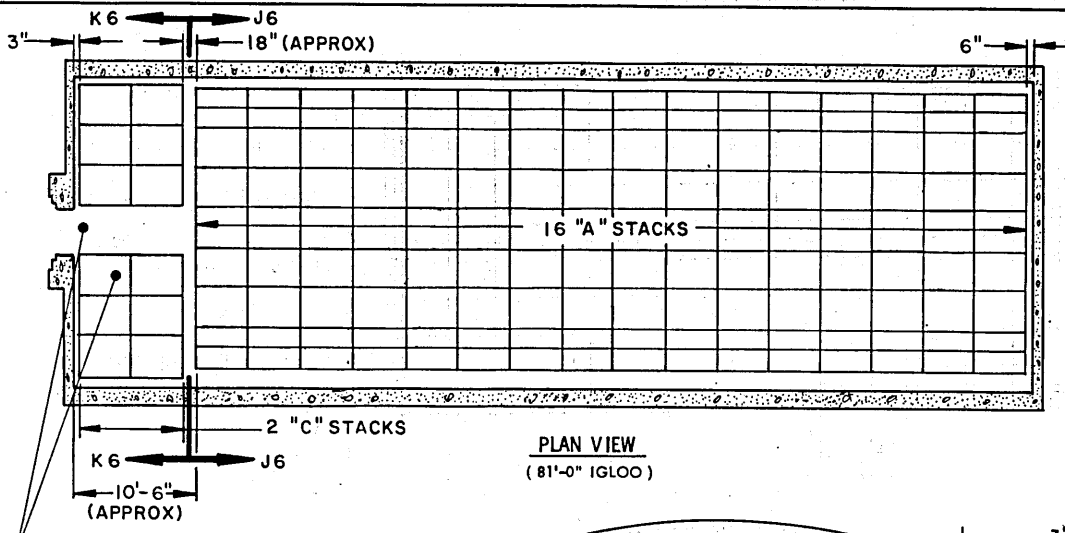

STORAGE IN 81'-0" IGLOO

ITEM	QUANTITY
PALLET UNITS	306

*** STORAGE IN 60'-8" IGLOO**

ITEM	QUANTITY
PALLET UNITS	216
* 11 A-STACKS	
2 C-STACKS	

**** STORAGE IN 40'-4" IGLOO**

ITEM	QUANTITY
PALLET UNITS	126
* 6 A-STACKS	
2 C-STACKS	

PLAN VIEW
(81'-0" IGLOO)

SEE GENERAL NOTE "G" ON PAGE 2.

SEE GENERAL NOTE "D" ON PAGE 2.

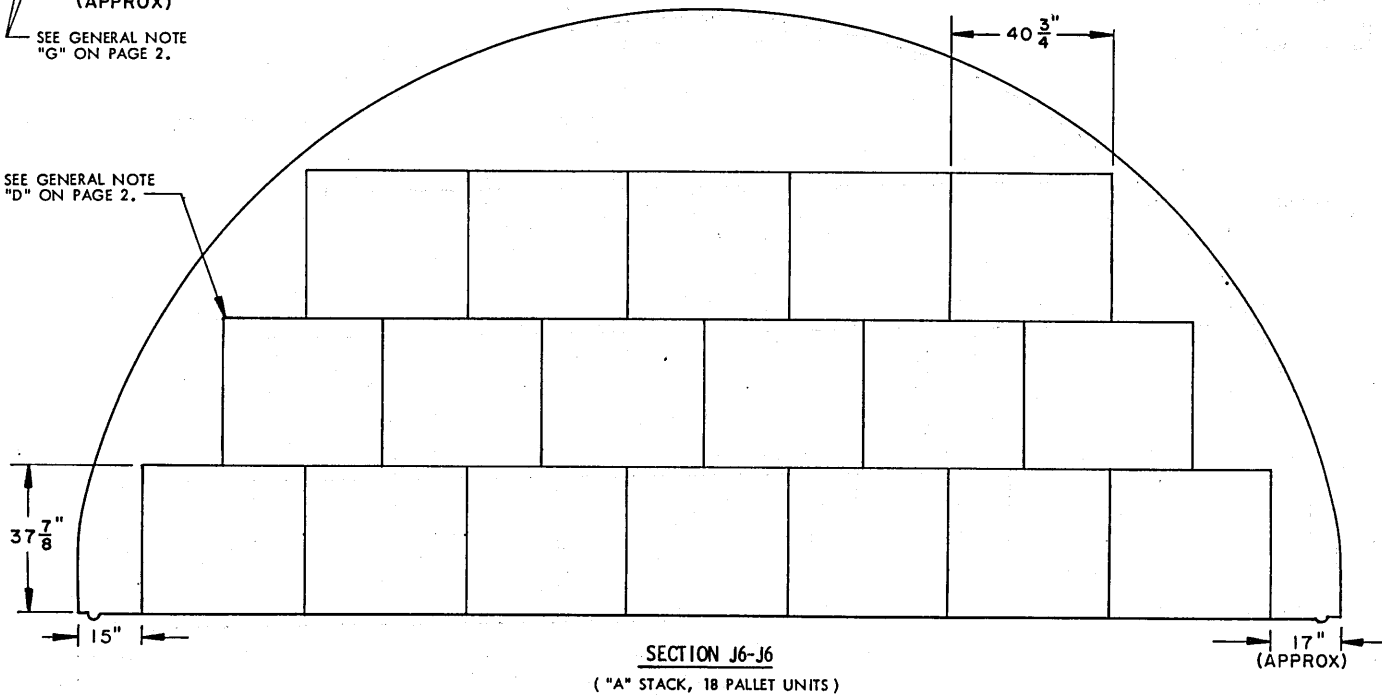

SECTION J6-J6
("A" STACK, 18 PALLET UNITS)

INDICATES OUTLINE OF DOOR OPENING.

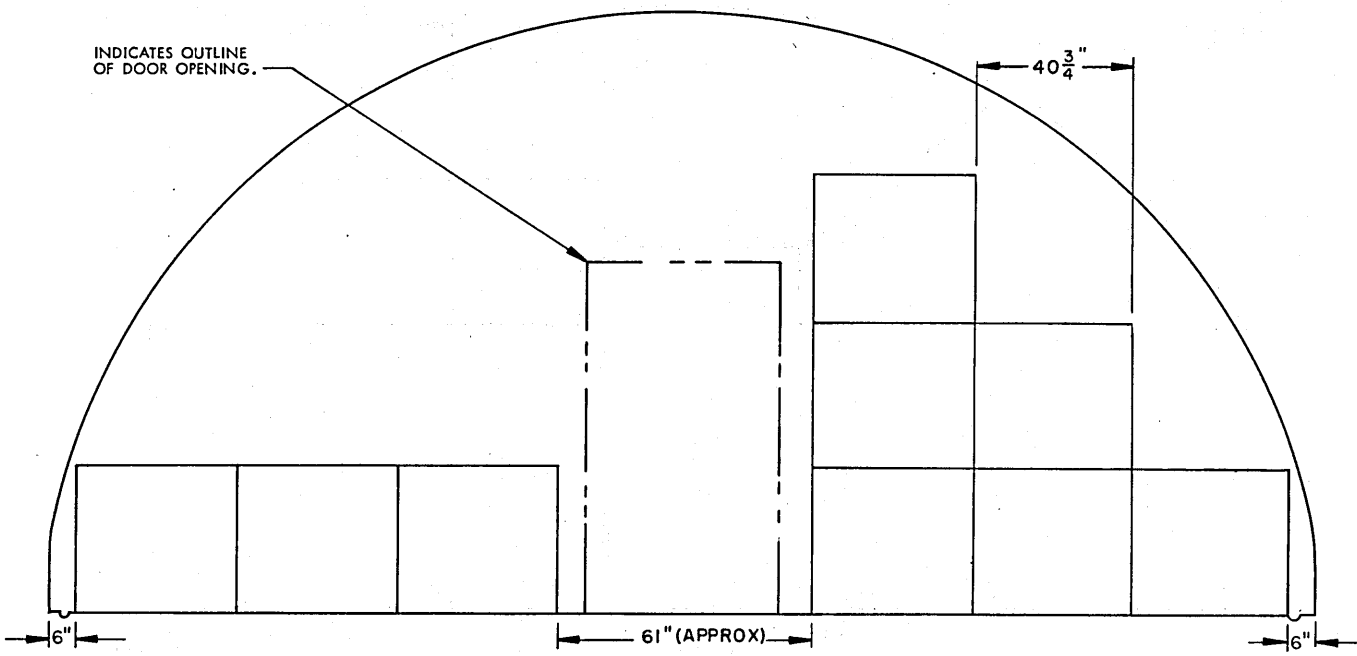

SECTION K6-K6 ("C" STACK, 9 PALLET UNITS)

STORAGE PROCEDURES FOR UNIT NO. 55 (DECREASED-HEIGHT UNIT)

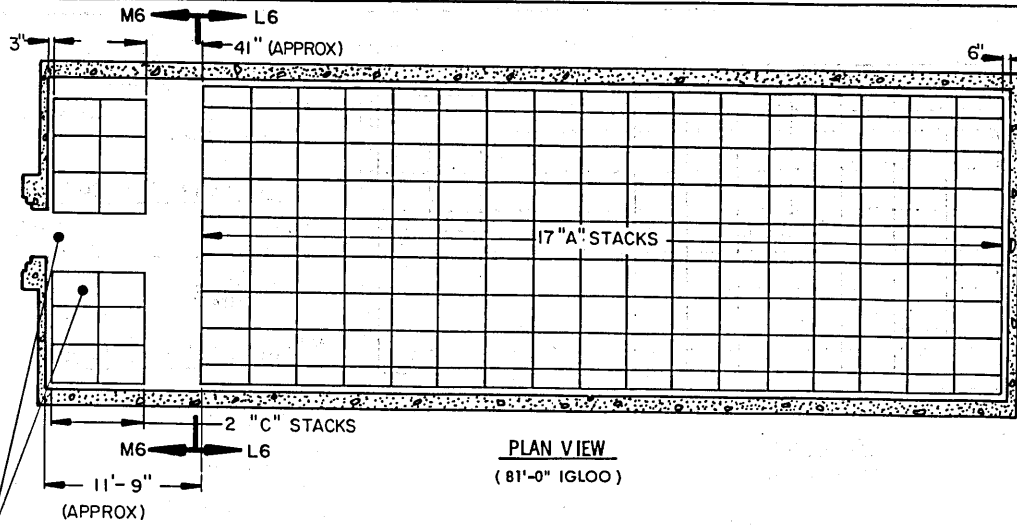

STORAGE IN 81'-0" IGLOO	
ITEM	QUANTITY
PALLET UNITS	379
* STORAGE IN 60'-8" IGLOO	
ITEM	QUANTITY
PALLET UNITS	285
* 12 A-STACKS	
3 C-STACKS	
** STORAGE IN 40'-4" IGLOO	
ITEM	QUANTITY
PALLET UNITS	169
** 7 A-STACKS	
2 C-STACKS	

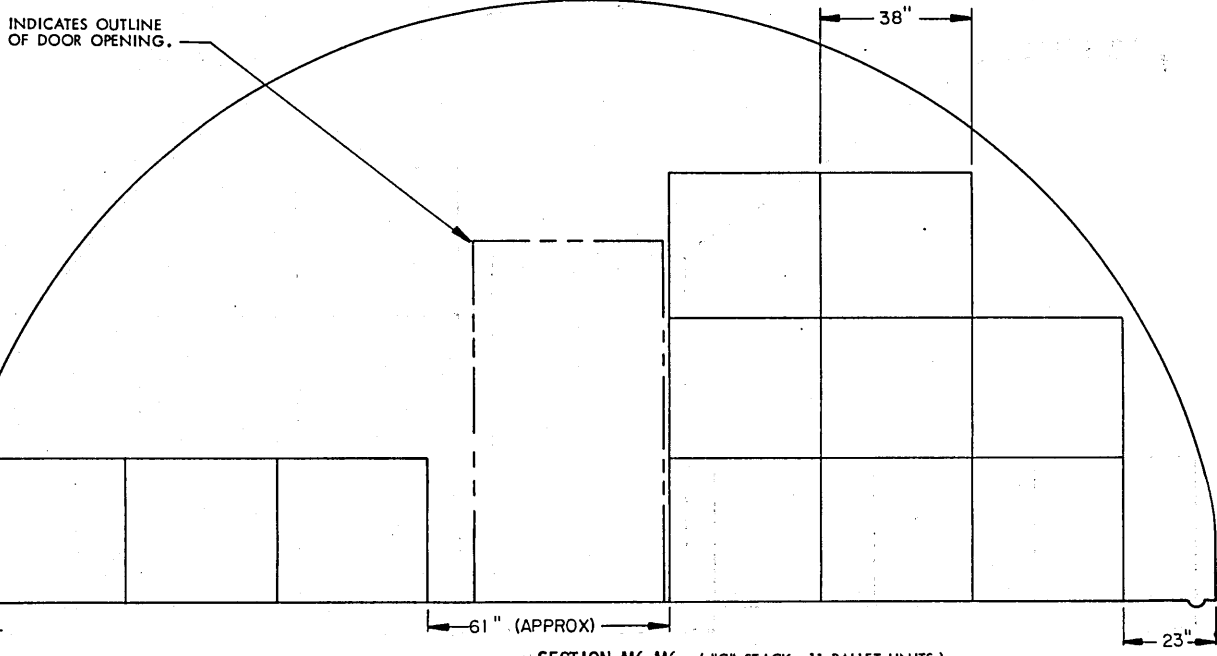
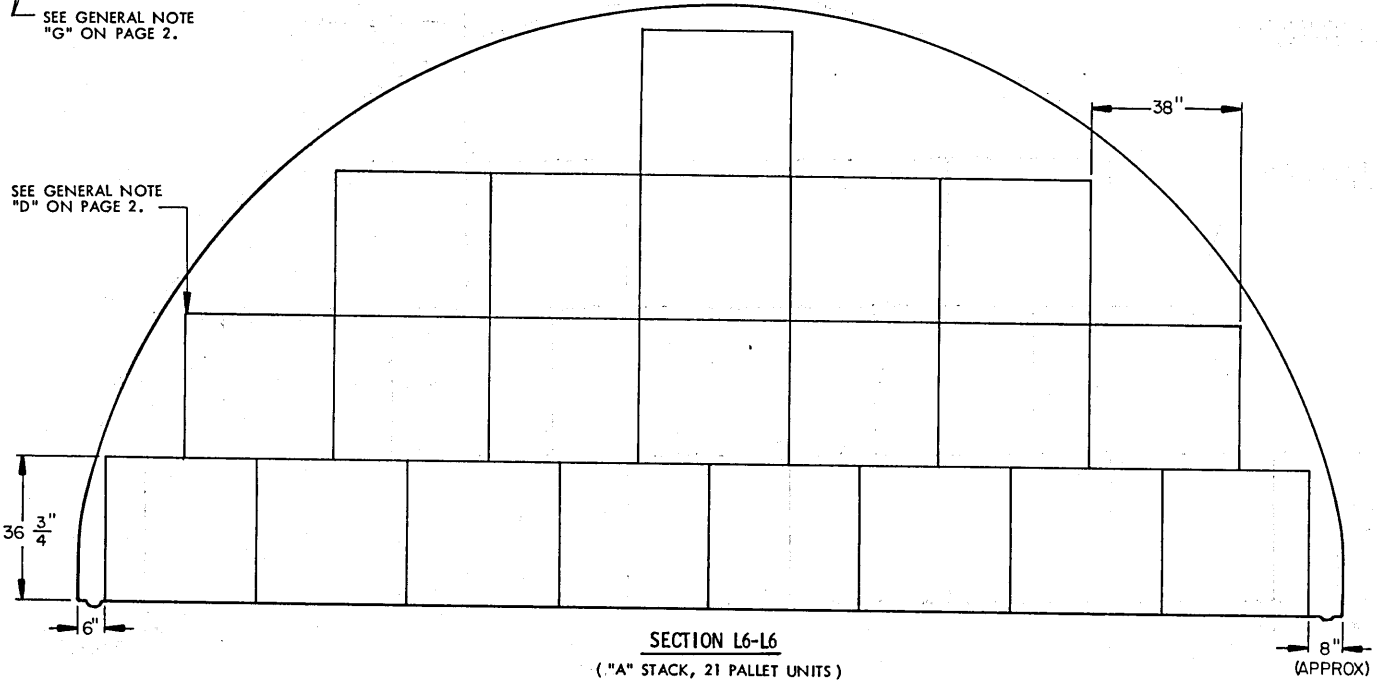

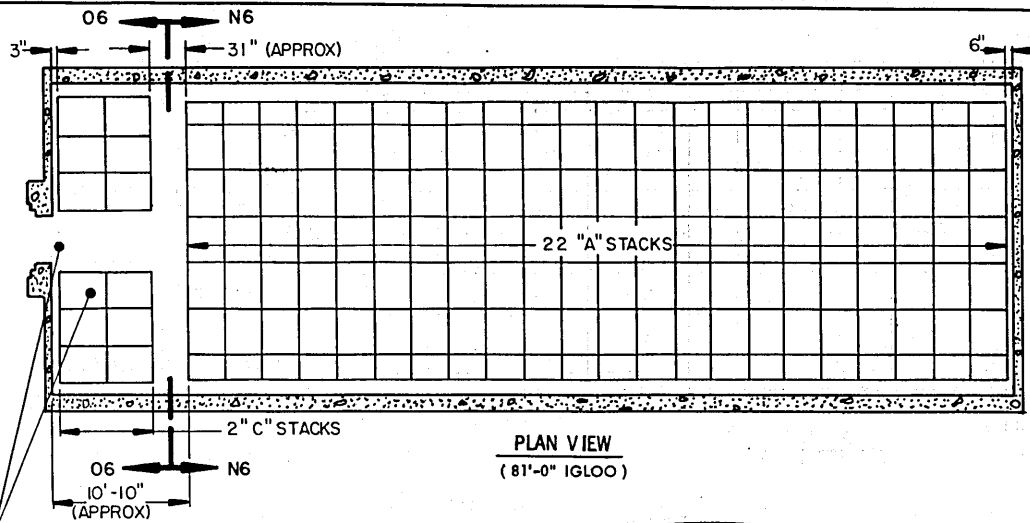

PLAN VIEW
(81'-0" IGLOO)

STORAGE IN 81'-0" IGLOO	
ITEM	QUANTITY
PALLET UNITS	326
* STORAGE IN 60'-8" IGLOO	
ITEM	QUANTITY
PALLET UNITS	237
* 15 A-STACKS	
3 C-STACKS	
** STORAGE IN 40'-4" IGLOO	
ITEM	QUANTITY
PALLET UNITS	144
** 9 A-STACKS	
2 C-STACKS	

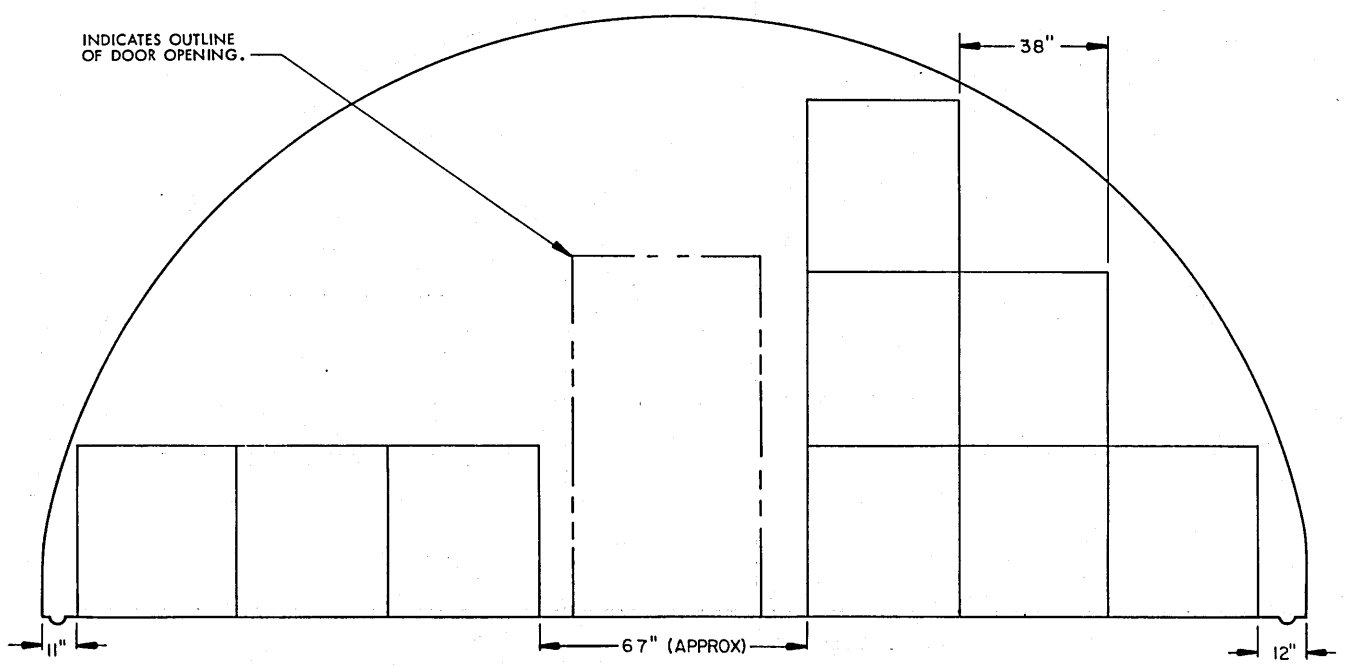
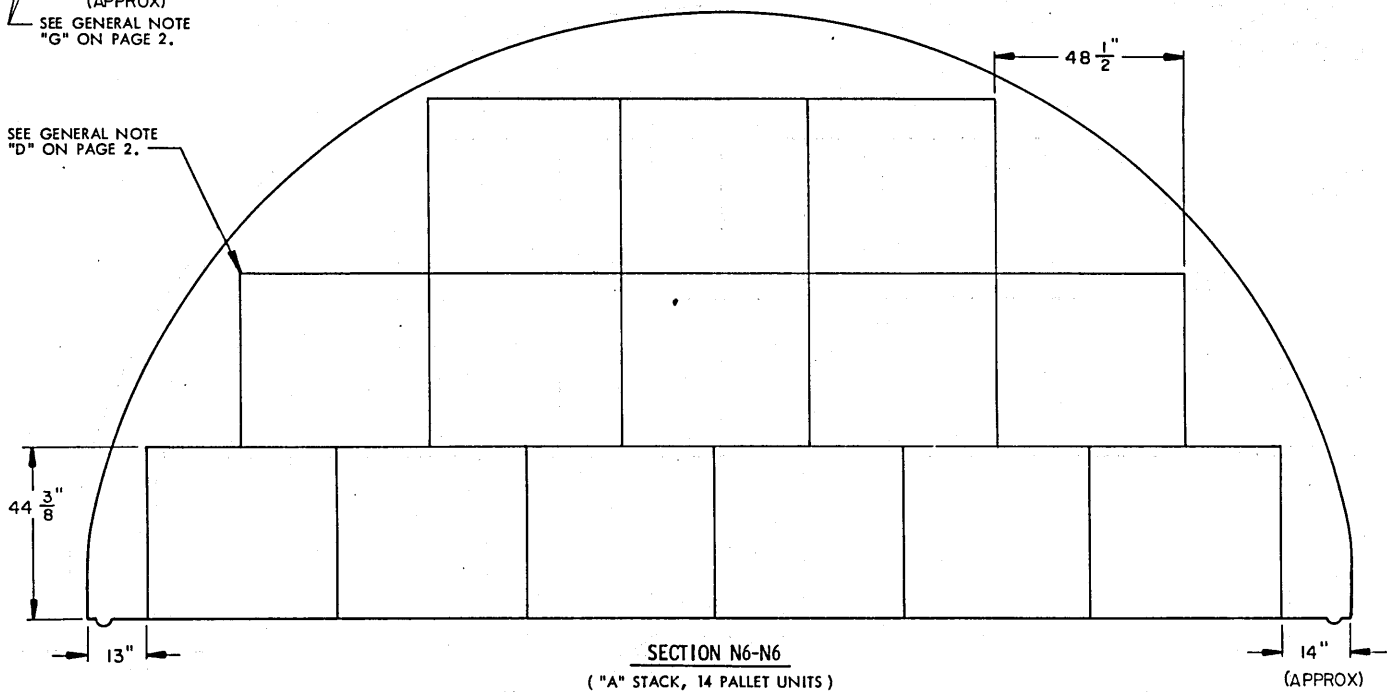

SECTION O6-O6 ("C" STACK, 9 PALLET UNITS)
STORAGE PROCEDURES FOR UNIT NO. 56 (INCREASED-HEIGHT UNIT)

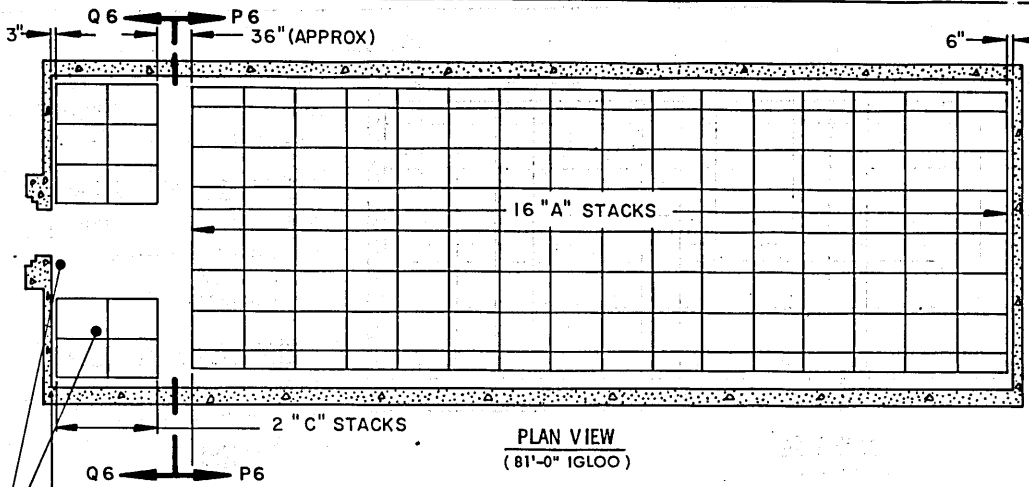

STORAGE IN 81'-0" IGLOO	
ITEM	QUANTITY
PALLET UNITS	288
* STORAGE IN 60'-8" IGLOO	
ITEM	QUANTITY
PALLET UNITS	203
* 11 A-STACKS	
2 C-STACKS	
** STORAGE IN 40'-4" IGLOO	
ITEM	QUANTITY
PALLET UNITS	126
** 6 A-STACKS	
3 C-STACKS	

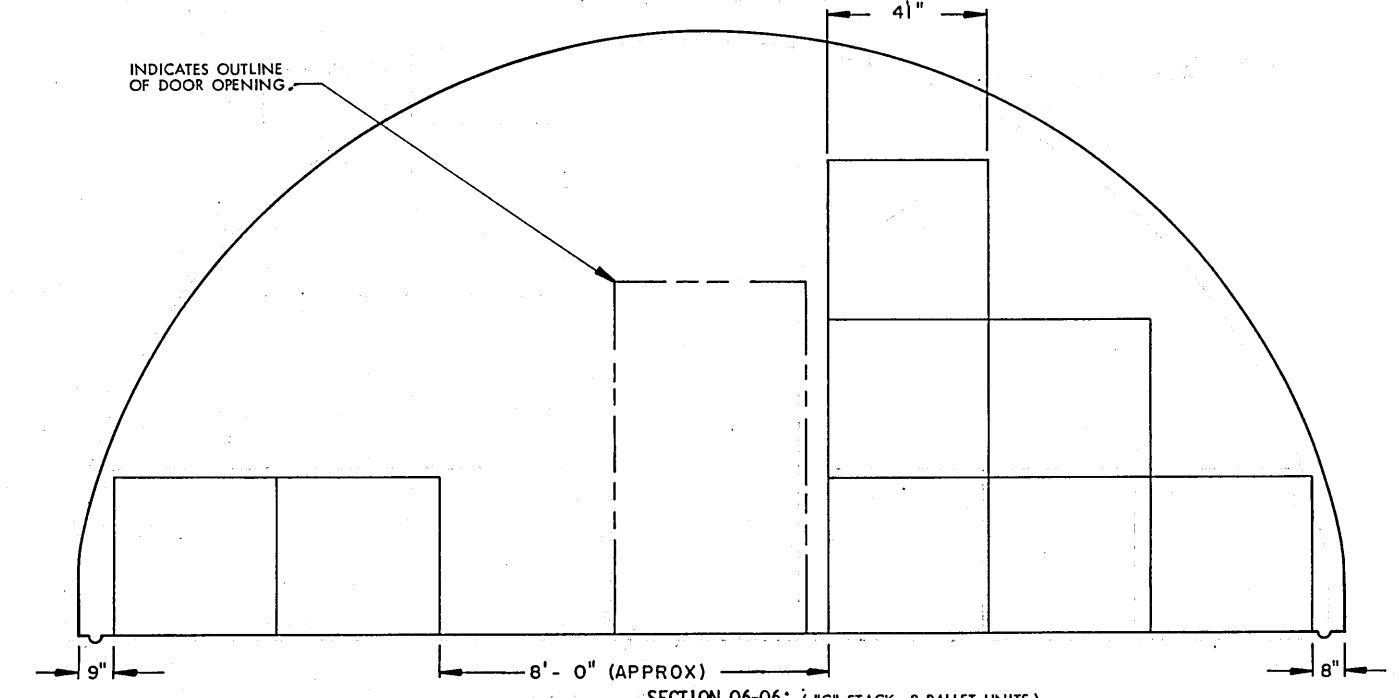
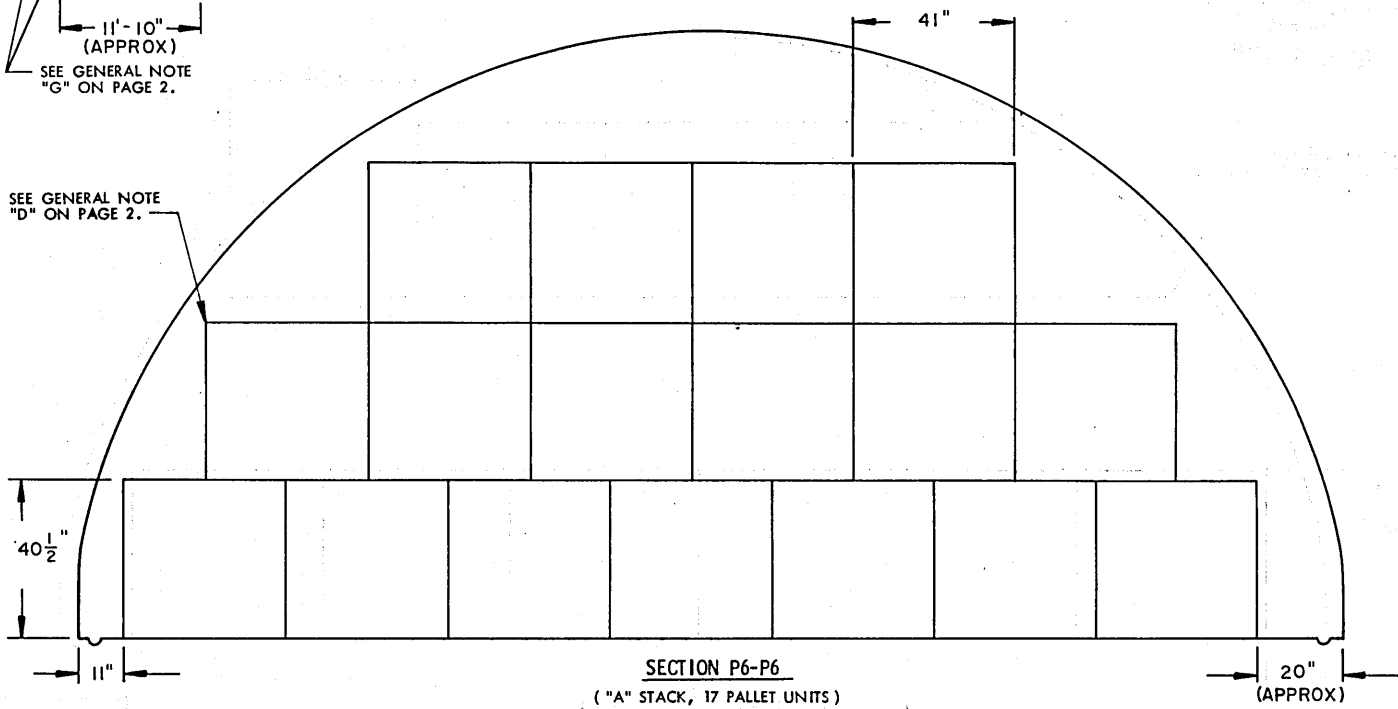

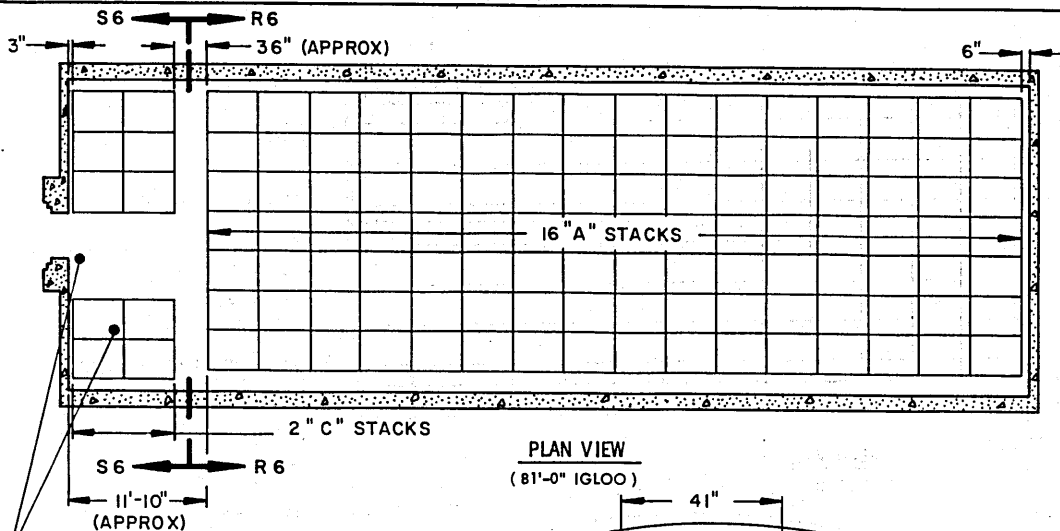

STORAGE IN 81'-0" IGLOO	
ITEM	QUANTITY
PALLET UNITS	222
* STORAGE IN 60'-8" IGLOO	
ITEM	QUANTITY
PALLET UNITS	157
* 11 A-STACKS	
2 C-STACKS	
** STORAGE IN 40'-4" IGLOO	
ITEM	QUANTITY
PALLET UNITS	99
** 6 A-STACKS	
3 C-STACKS	

PLAN VIEW
(81'-0" IGLOO)

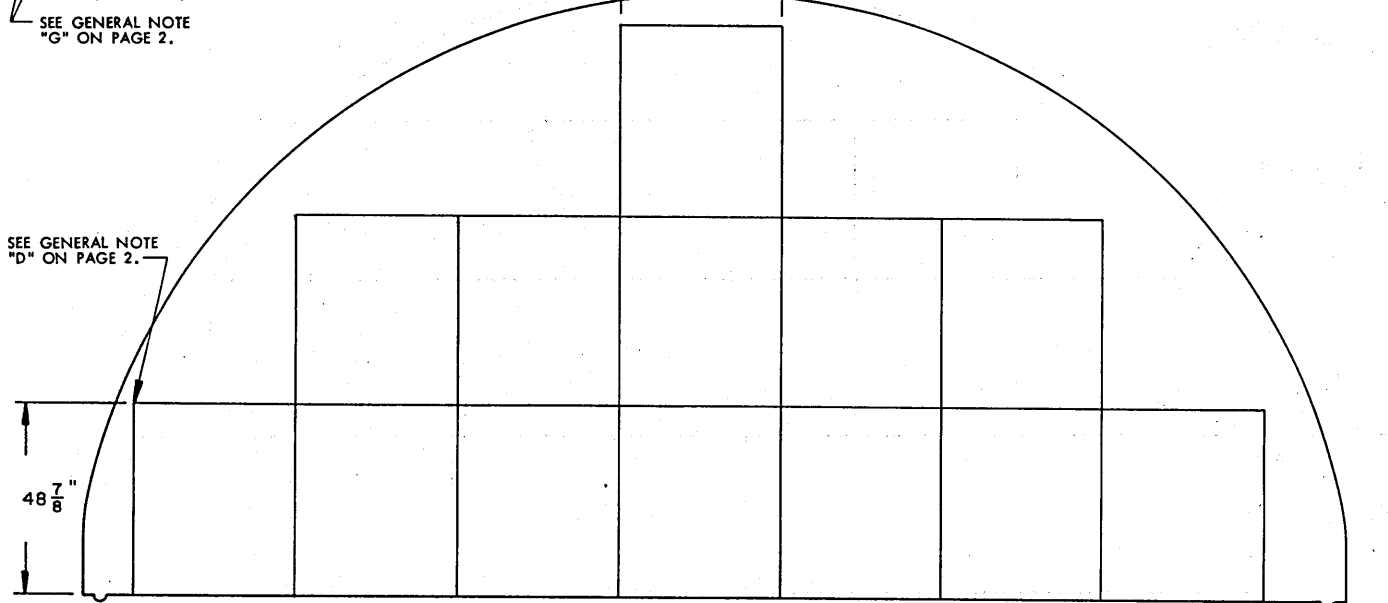

SECTION R6-R6
("A" STACK, 13 PALLET UNITS)

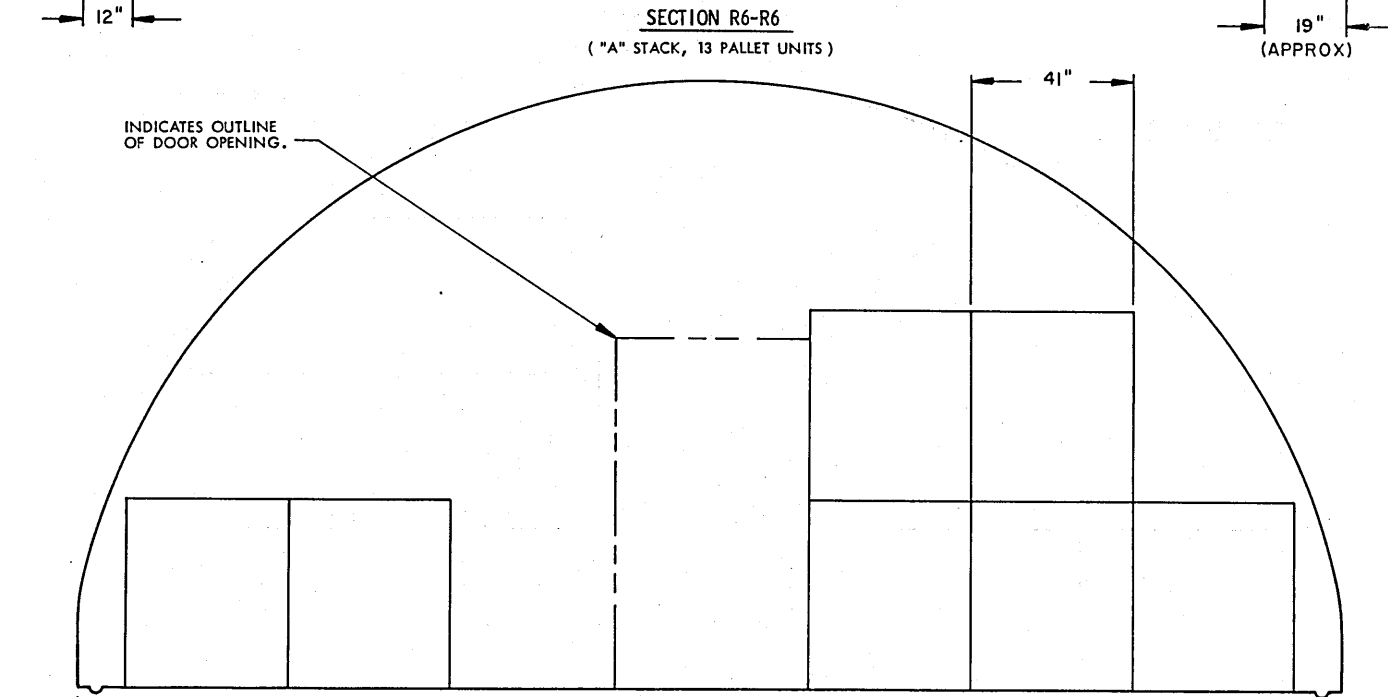

SECTION S6-S6 ("C" STACK, 7 PALLET UNITS)
STORAGE PROCEDURES FOR UNIT NO. 57 (INCREASED-HEIGHT UNIT)

U6 T6
3" 32" (APPROX) 6"

STORAGE IN 81'-0" IGLOO

ITEM	QUANTITY
PALLET UNITS	293

*** STORAGE IN 60'-8" IGLOO**

ITEM	QUANTITY
PALLET UNITS	208

* 11 A-STACKS
3 C-STACKS

**** STORAGE IN 40'-4" IGLOO**

ITEM	QUANTITY
PALLET UNITS	140

** 7 A-STACKS
3 C-STACKS

16 "A" STACKS

3 "C" STACKS

PLAN VIEW
(81'-0" IGLOO)

U6 T6
13'-2" (APPROX)

SEE GENERAL NOTE "G" ON PAGE 2.

SEE GENERAL NOTE "D" ON PAGE 2.

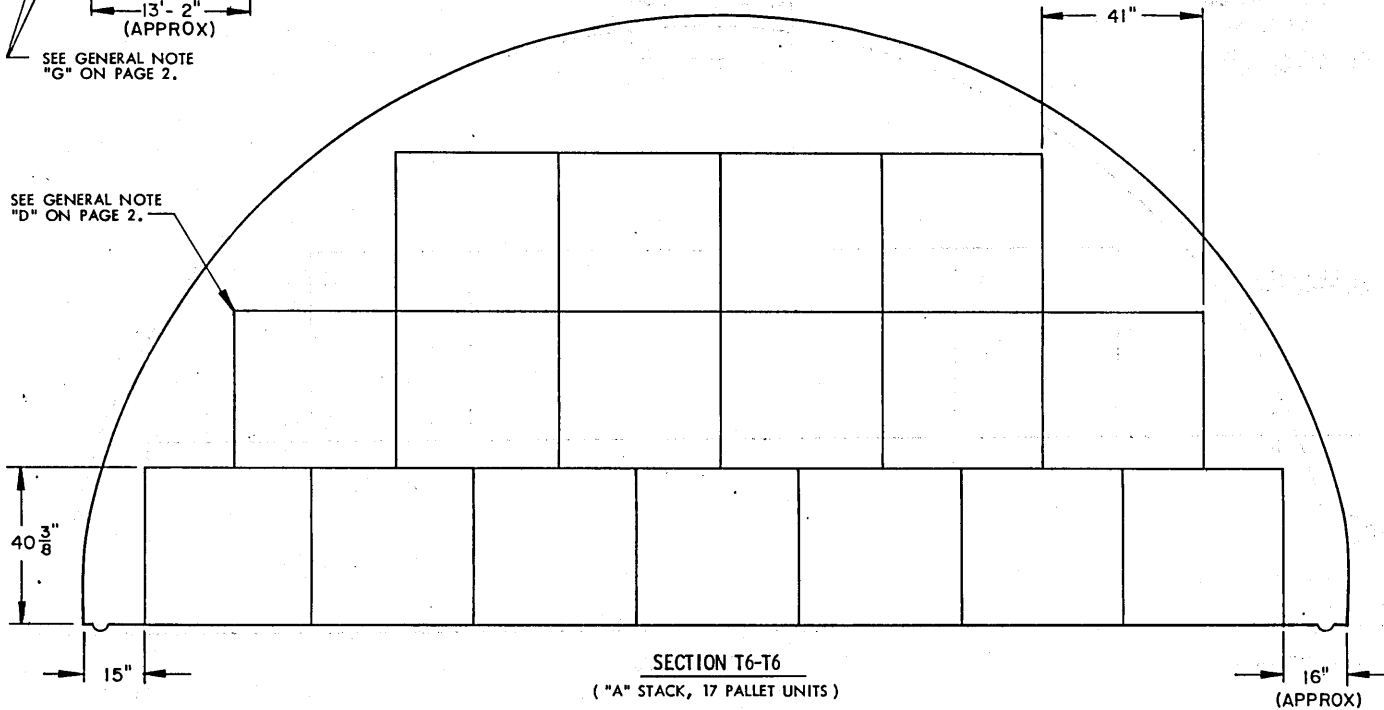

INDICATES OUTLINE OF DOOR OPENING.

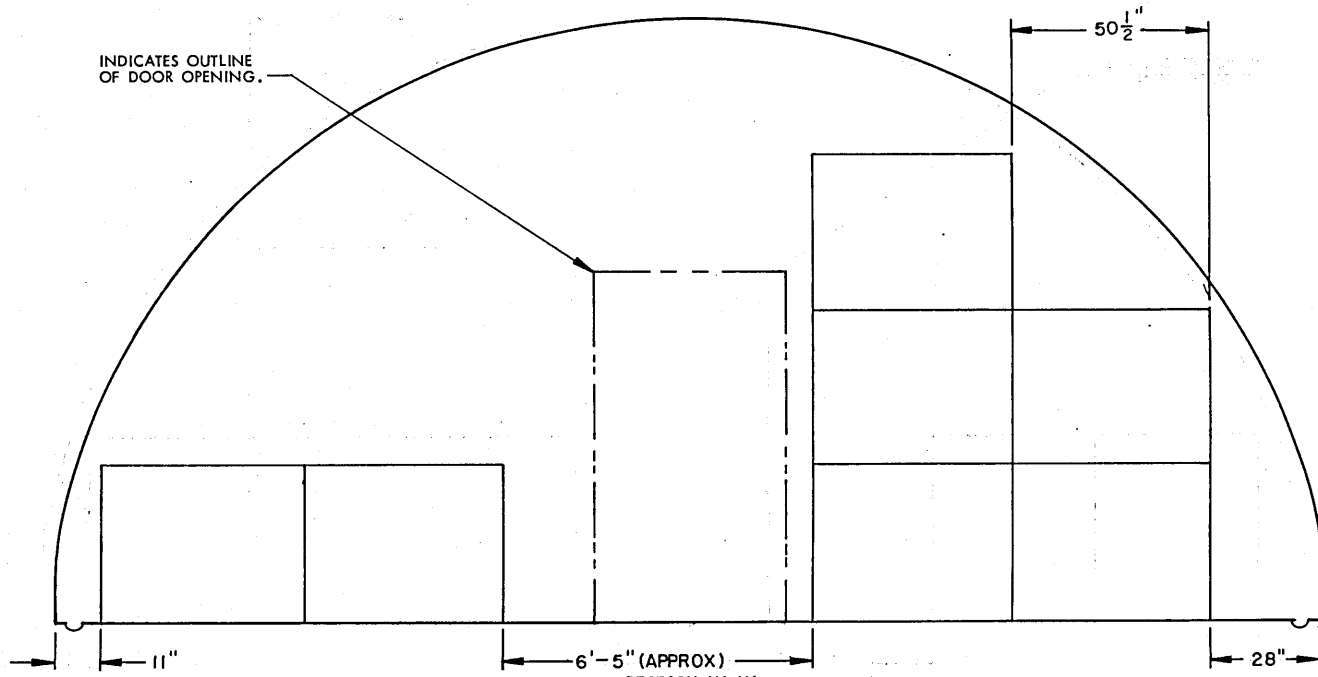

STORAGE PROCEDURES FOR UNIT NO. 58

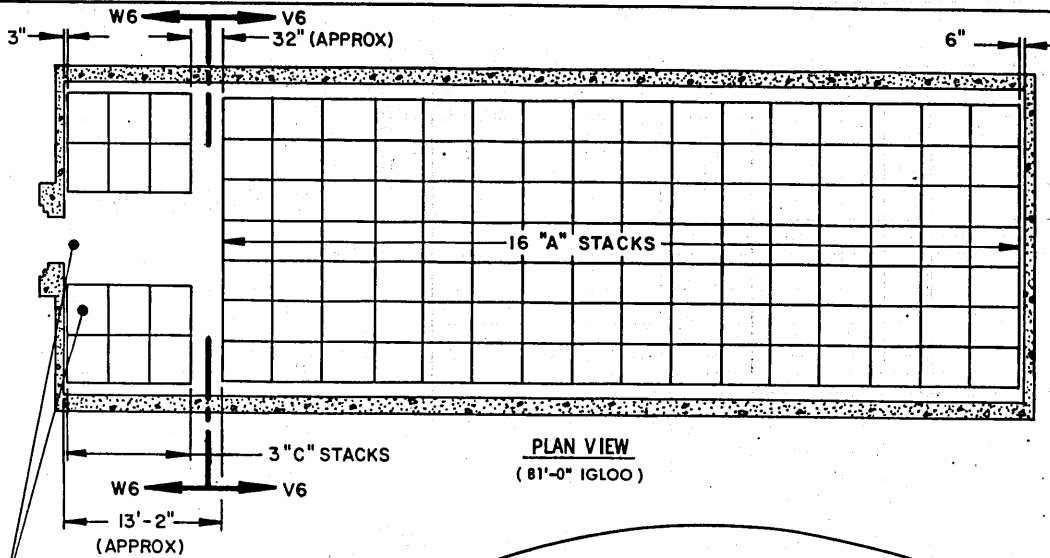

STORAGE IN 81'-0" IGLOO	
ITEM	QUANTITY
PALLET UNITS -----	223
* STORAGE IN 60'-8" IGLOO	
ITEM	QUANTITY
PALLET UNITS -----	158
* 11 A-STACKS	
3 C-STACKS	
** STORAGE IN 40'-4" IGLOO	
ITEM	QUANTITY
PALLET UNITS -----	106
** 7 A-STACKS	
3 C-STACKS	

SEE GENERAL NOTE "G" ON PAGE 2.

SEE GENERAL NOTE "D" ON PAGE 2.

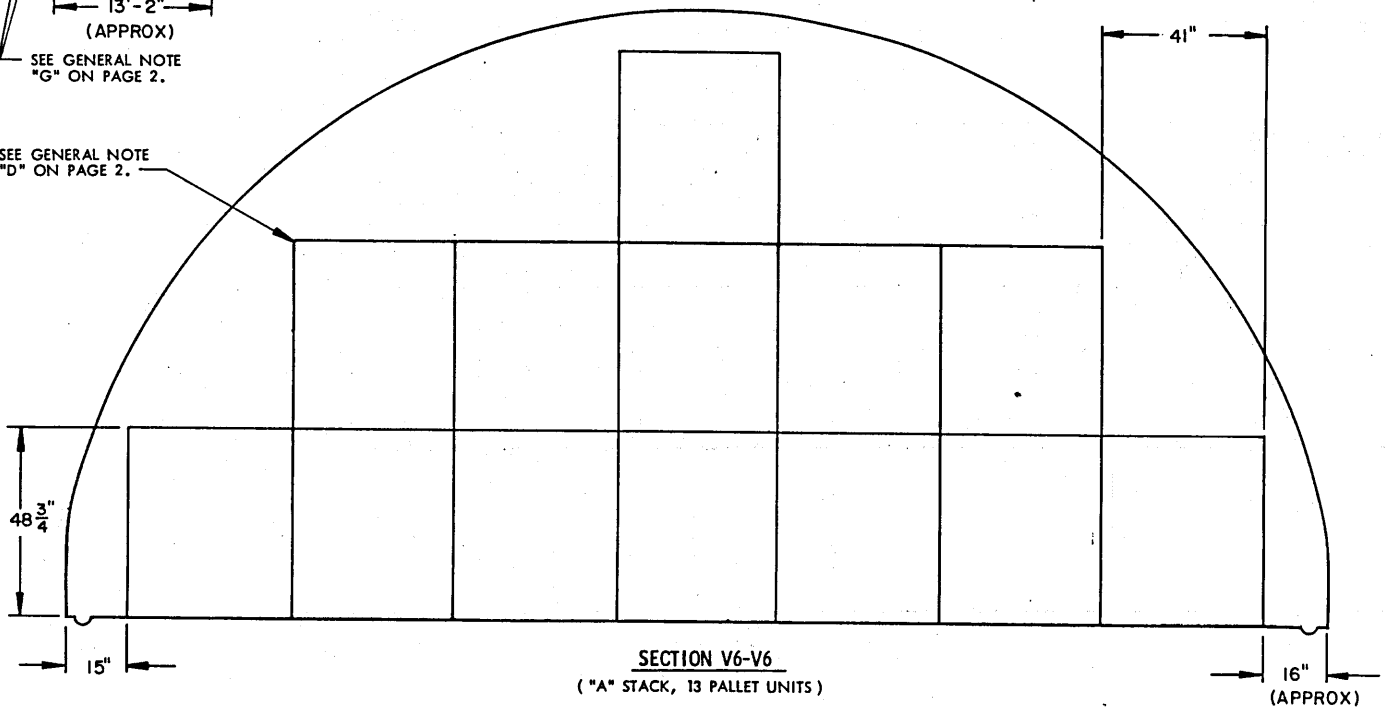

INDICATES OUTLINE OF DOOR OPENING.

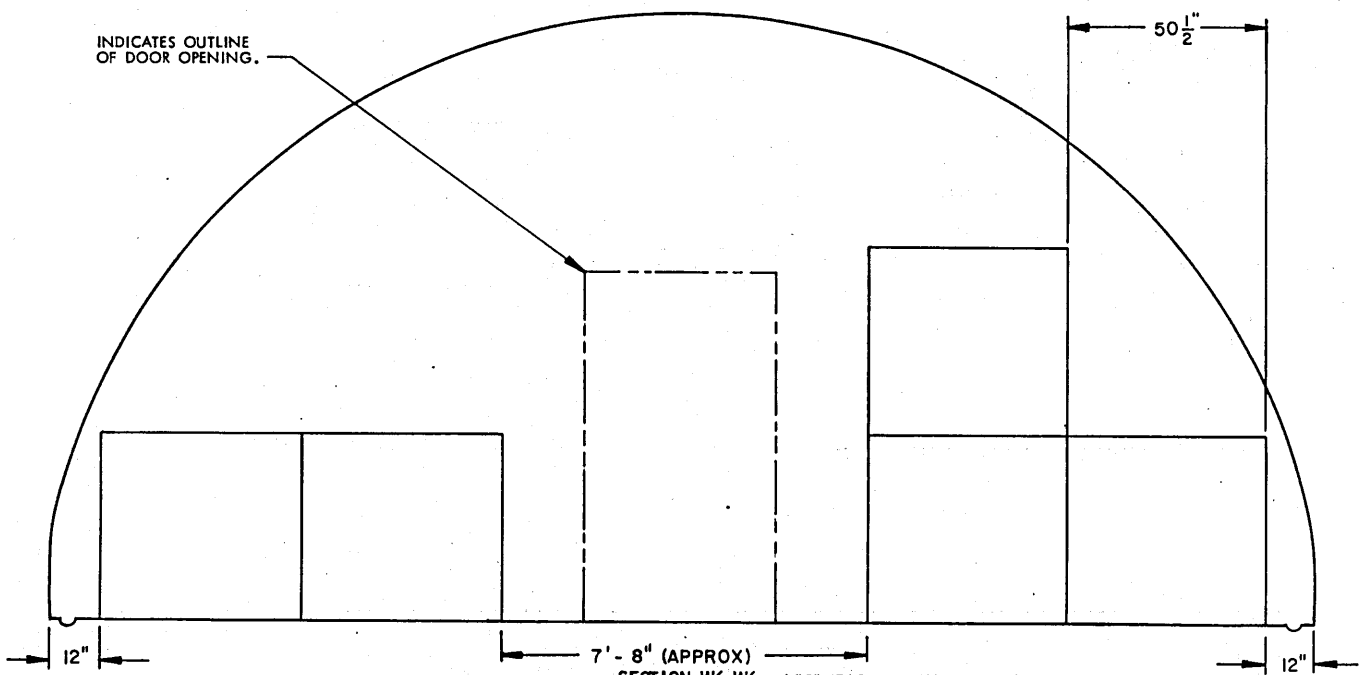

STORAGE PROCEDURES FOR UNIT NO. 58 (INCREASED-HEIGHT UNIT)

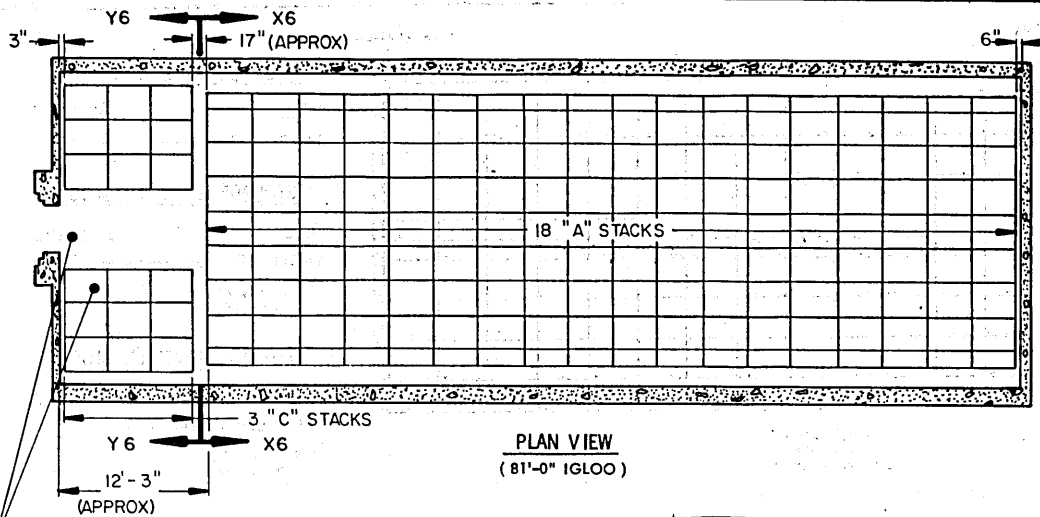

PLAN VIEW
(81'-0" IGLOO)

STORAGE IN 81'-0" IGLOO	
ITEM	QUANTITY
PALLET UNITS	387
* STORAGE IN 60'-8" IGLOO	
ITEM	QUANTITY
PALLET UNITS	278
* 13 A-STACKS	
2 C-STACKS	
** STORAGE IN 40'-4" IGLOO	
ITEM	QUANTITY
PALLET UNITS	167
** 7 A-STACKS	
3 C-STACKS	

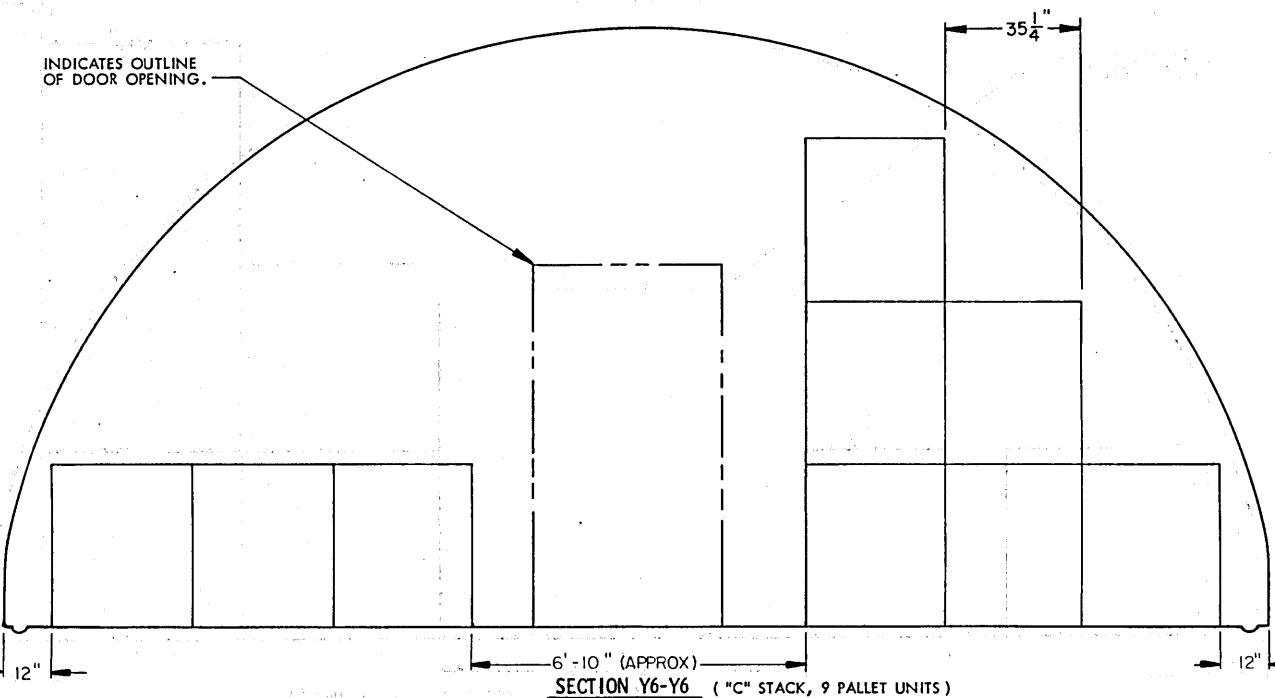
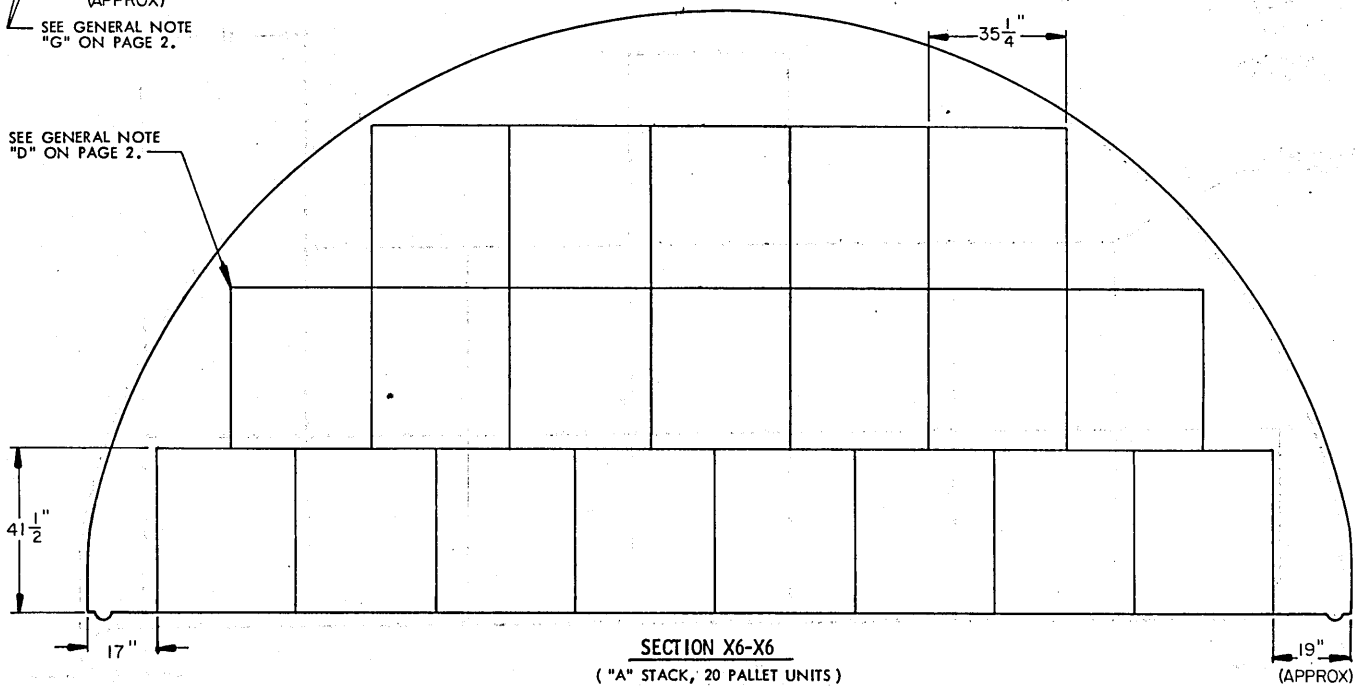

STORAGE PROCEDURES FOR UNIT NO. 59

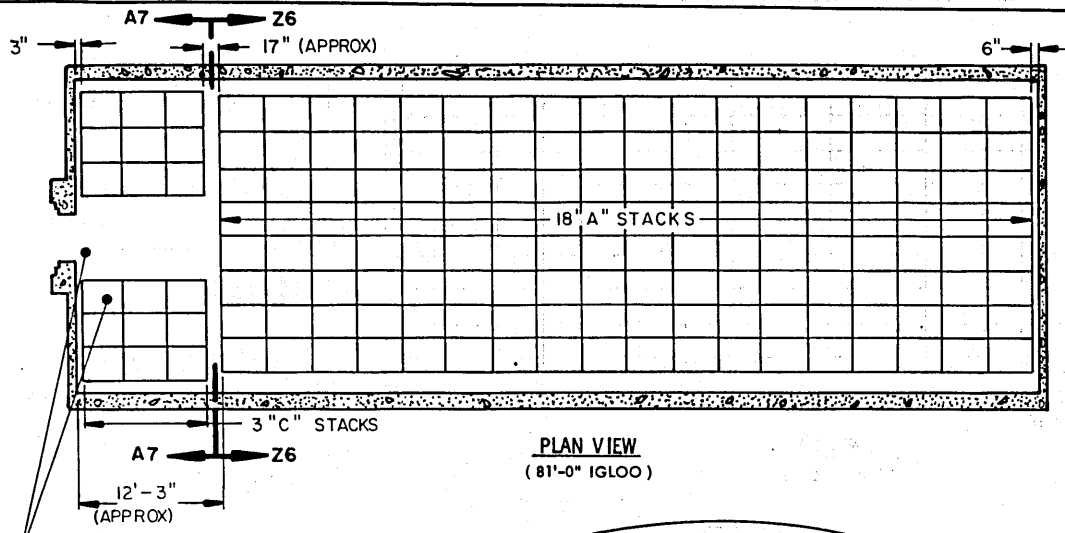

STORAGE IN 81'-0" IGLOO	
ITEM	QUANTITY
PALLET UNITS	312
* STORAGE IN 60'-8" IGLOO	
ITEM	QUANTITY
PALLET UNITS	224
* 13 A-STACKS	
2 C-STACKS	
** STORAGE IN 40'-4" IGLOO	
ITEM	QUANTITY
PALLET UNITS	136
** 7 A-STACKS	
3 C-STACKS	

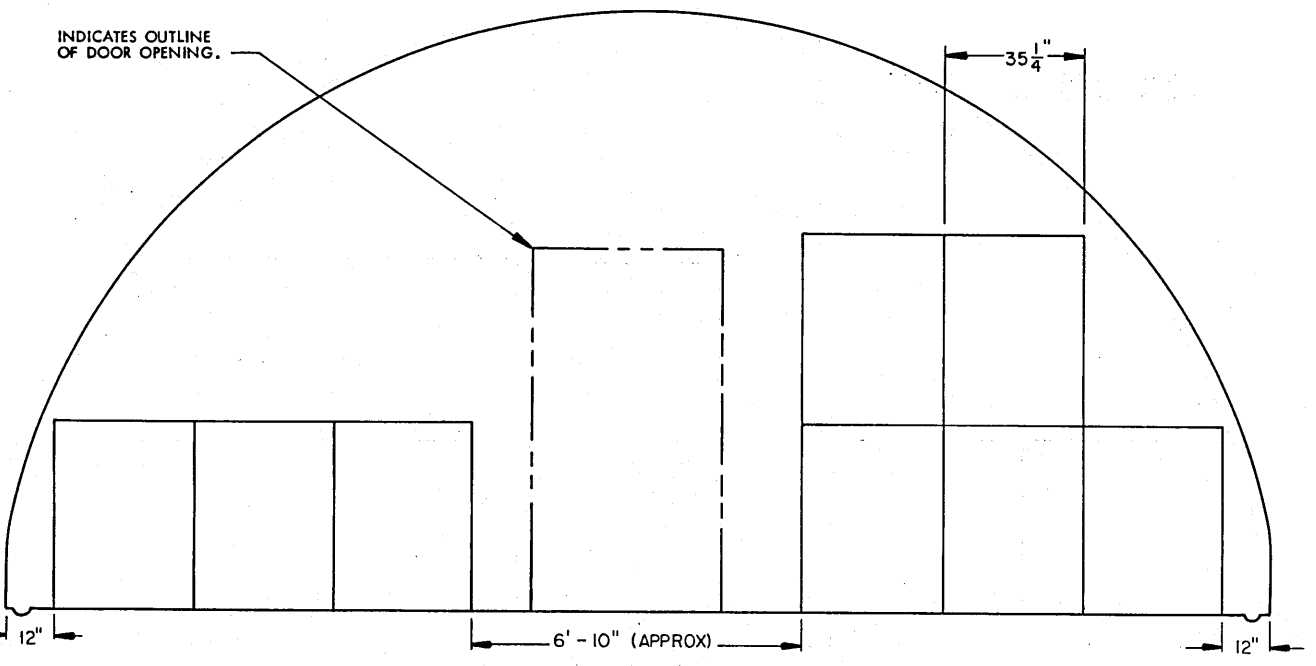
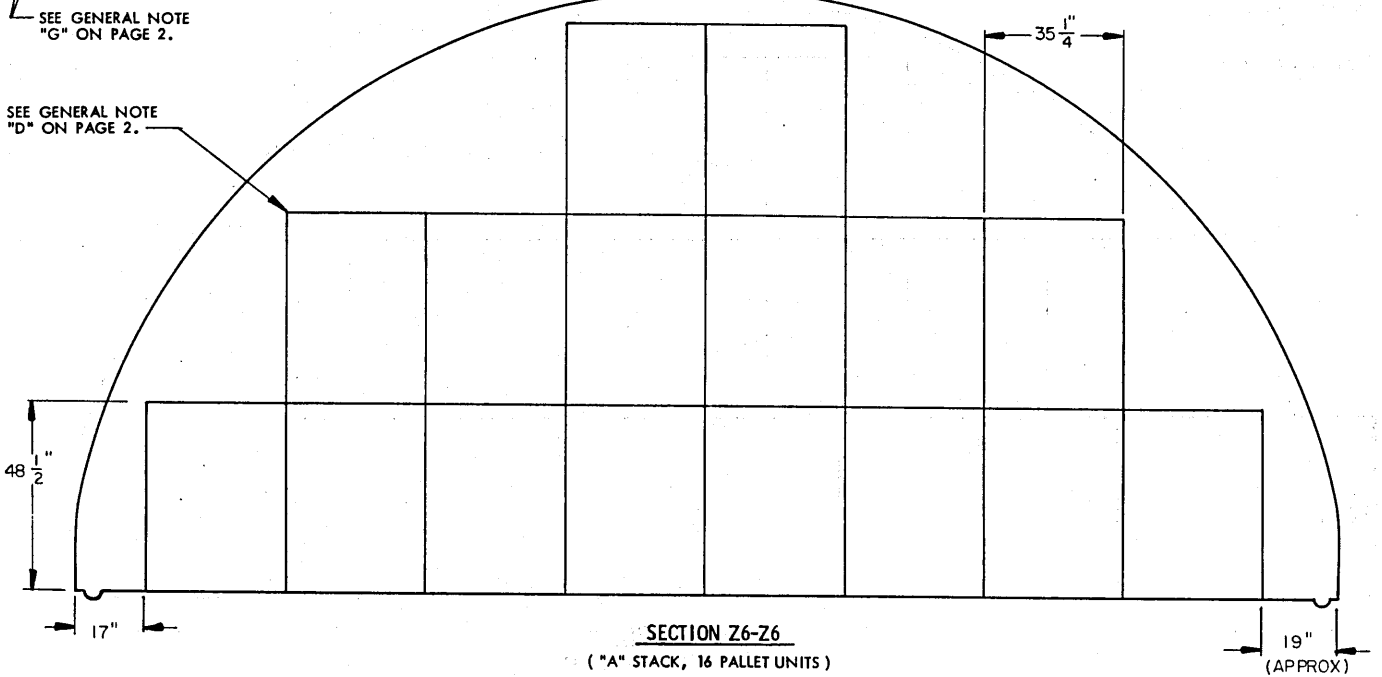

STORAGE PROCEDURES FOR UNIT NO. 59 (INCREASED-HEIGHT UNIT)

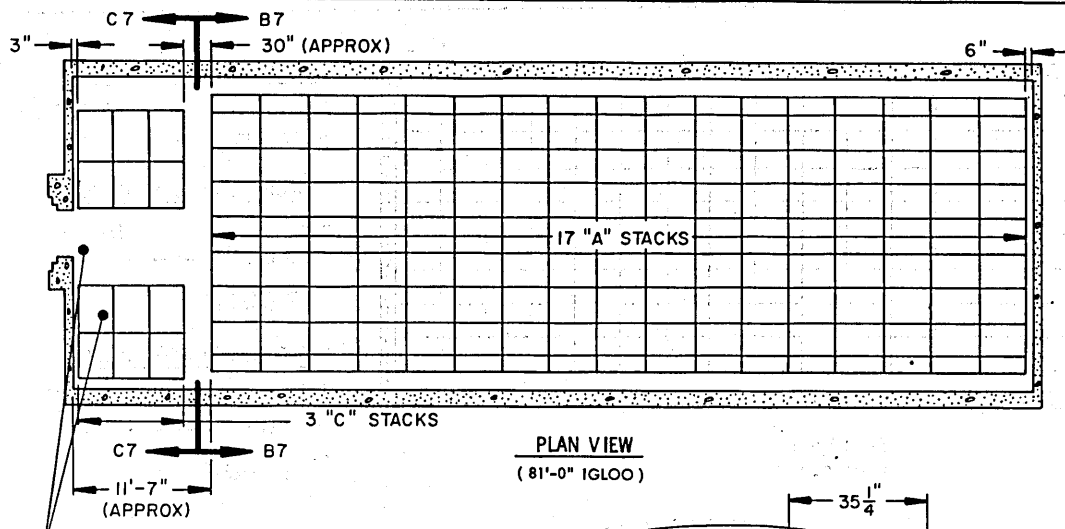

PLAN VIEW
(81'-0" IGLOO)

STORAGE IN 81'-0" IGLOO

ITEM	QUANTITY
PALLET UNITS	324

*** STORAGE IN 60'-8" IGLOO**

ITEM	QUANTITY
PALLET UNITS	234
* 12 A-STACKS	
3 C-STACKS	

**** STORAGE IN 40'-4" IGLOO**

ITEM	QUANTITY
PALLET UNITS	144
* 7 A-STACKS	
3 C-STACKS	

SEE GENERAL NOTE "G" ON PAGE 2.

SEE GENERAL NOTE "D" ON PAGE 2.

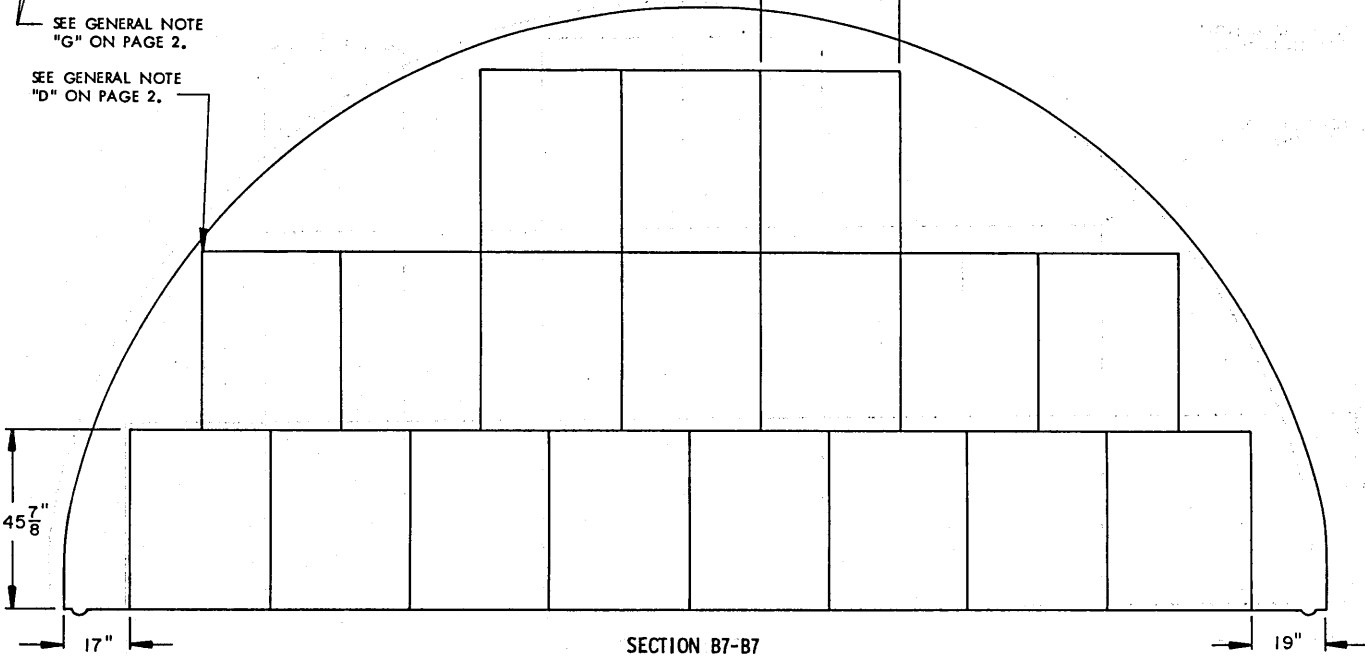

SECTION B7-B7
("A" STACK, 18 PALLET UNITS)

INDICATES OUTLINE OF DOOR OPENING.

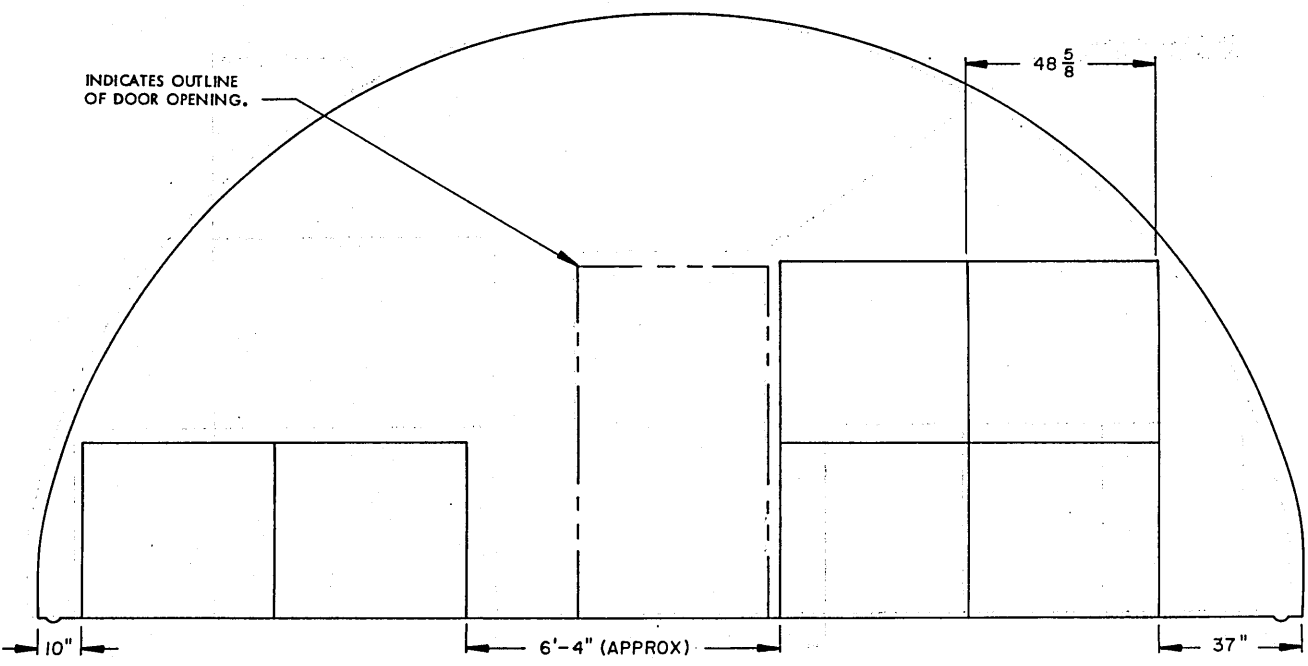

SECTION C7-C7 ("C" STACK, 6 PALLET UNITS)

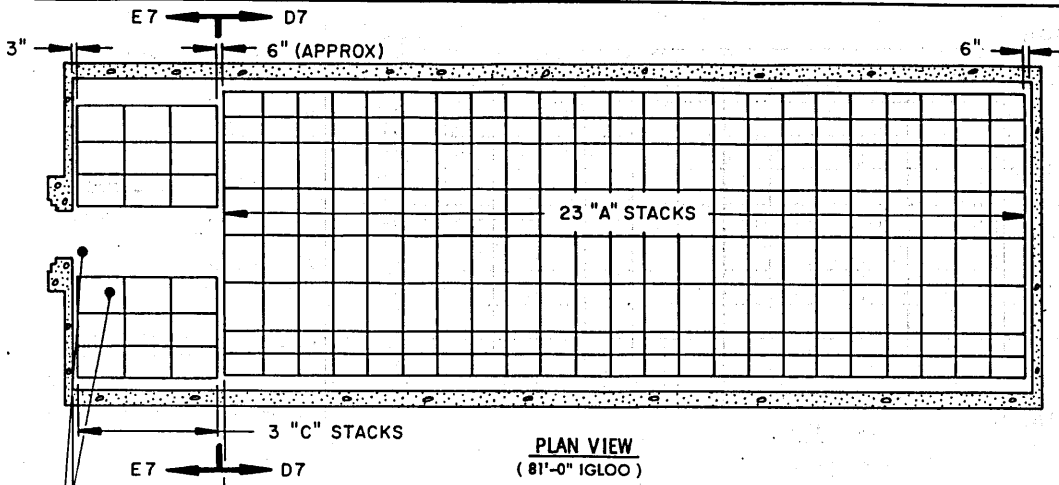

STORAGE IN 81'-0" IGLOO	
ITEM	QUANTITY
PALLET UNITS	378
* STORAGE IN 60'-8" IGLOO	
ITEM	QUANTITY
PALLET UNITS	273
* 16 A-STACKS	
3 C-STACKS	
** STORAGE IN 40'-4" IGLOO	
ITEM	QUANTITY
PALLET UNITS	168
** 9 A-STACKS	
3 C-STACKS	

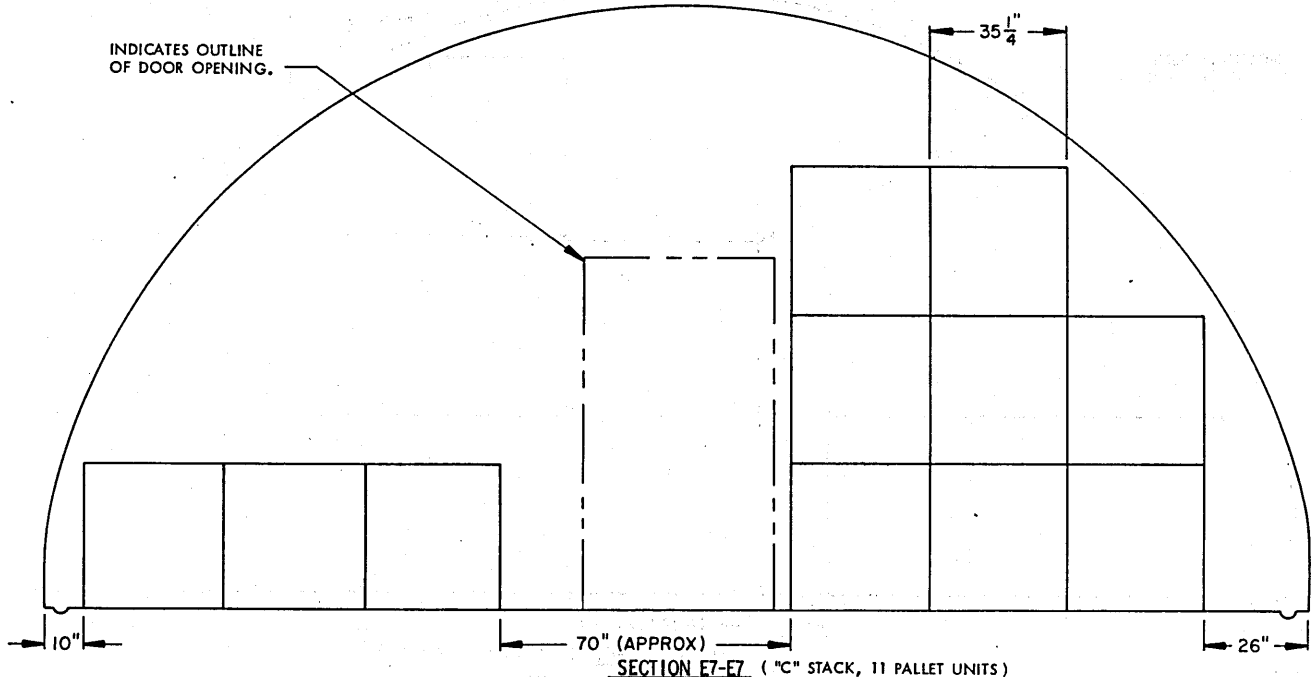
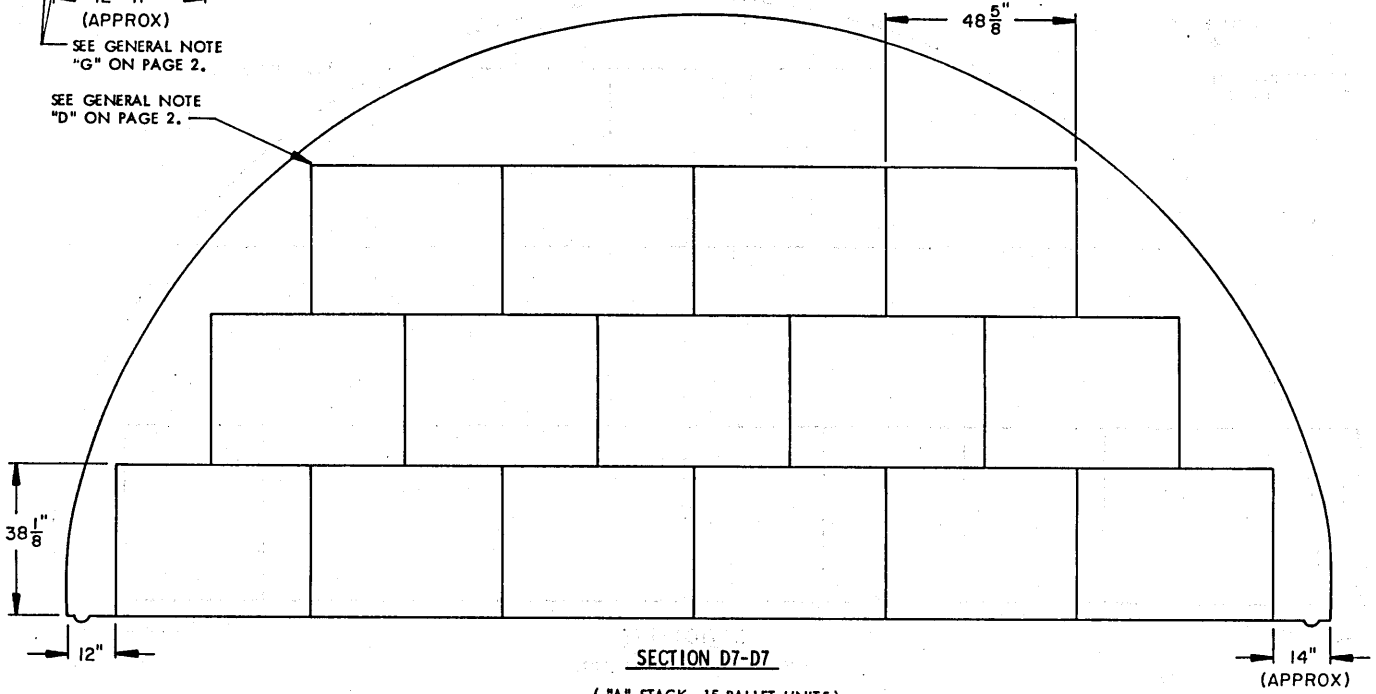

STORAGE PROCEDURES FOR UNIT NO. 60 (DECREASED-HEIGHT UNIT)

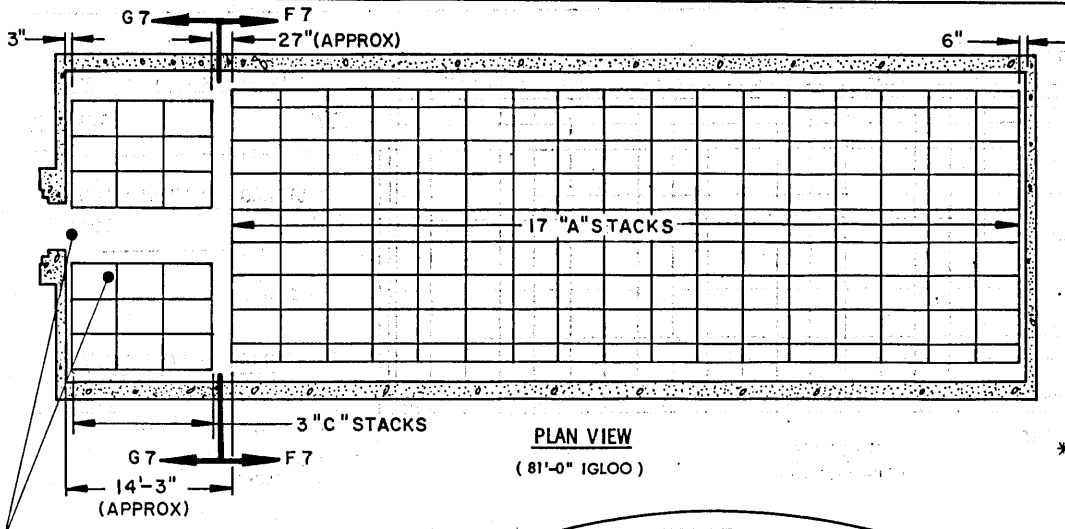

PLAN VIEW
(81'-0" IGLOO)

STORAGE IN 81'-0" IGLOO

ITEM	QUANTITY
PALLET UNITS	333

*** STORAGE IN 60'-8" IGLOO**

ITEM	QUANTITY
PALLET UNITS	243
* 12 A-STACKS	
3 C-STACKS	

*** * STORAGE IN 40'-4" IGLOO**

ITEM	QUANTITY
PALLET UNITS	153
* * 7 A-STACKS	
3 C-STACKS	

SEE GENERAL NOTE "G" ON PAGE 2.

SEE GENERAL NOTE "D" ON PAGE 2.

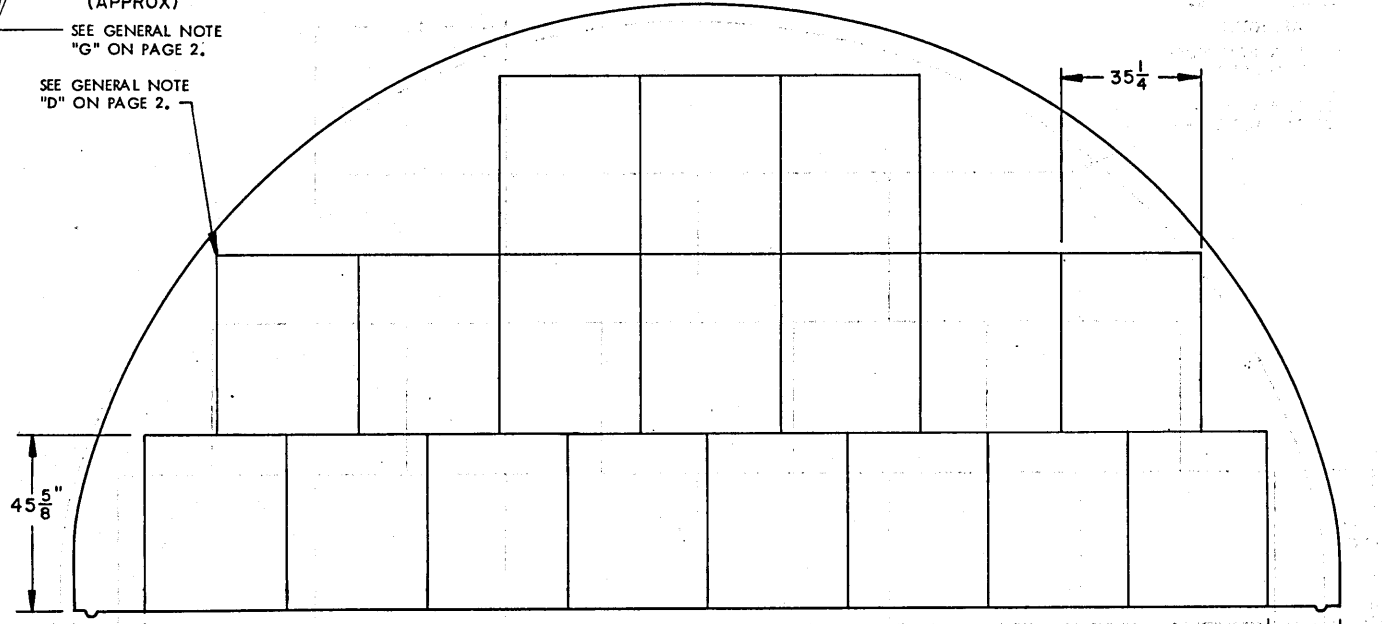

SECTION F7-F7
("A" STACK, 18 PALLET UNITS)

INDICATES OUTLINE OF DOOR OPENING.

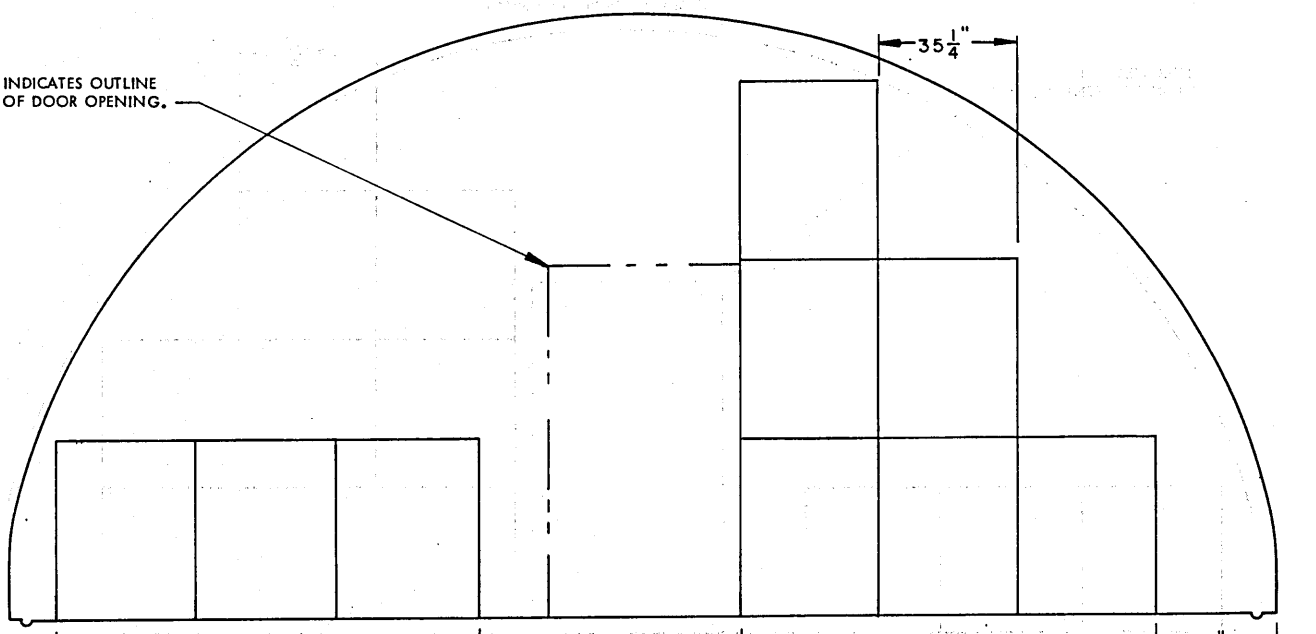

SECTION G7-G7 ("C" STACK, 9 PALLET UNITS)

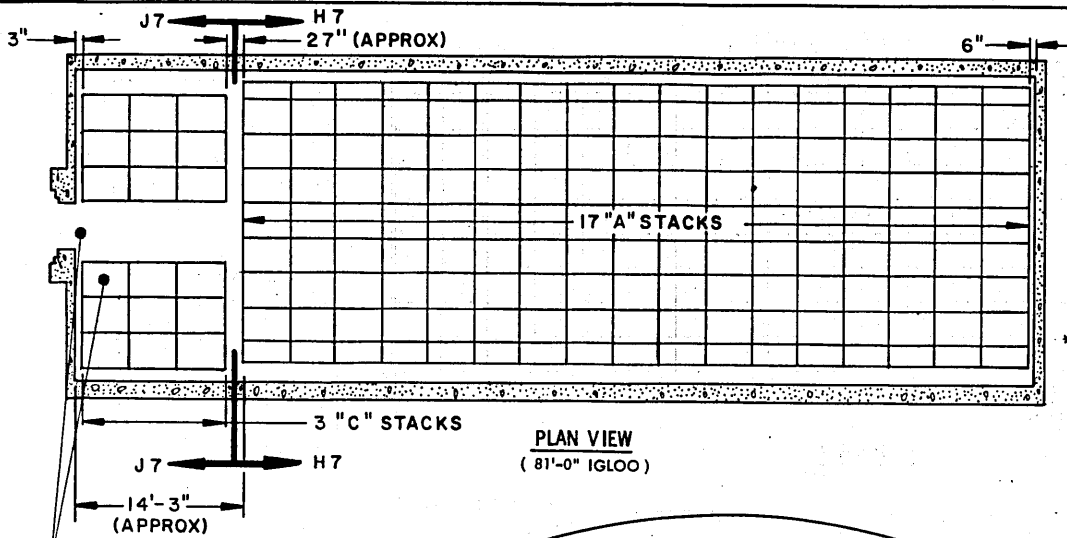

STORAGE IN 81'-0" IGLOO	
ITEM	QUANTITY
PALLET UNITS	373
* STORAGE IN 60'-8" IGLOO	
ITEM	QUANTITY
PALLET UNITS	273
* 12 A-STACKS	
3 C-STACKS	
** STORAGE IN 40'-4" IGLOO	
ITEM	QUANTITY
PALLET UNITS	173
** 7 A-STACKS	
3 C-STACKS	

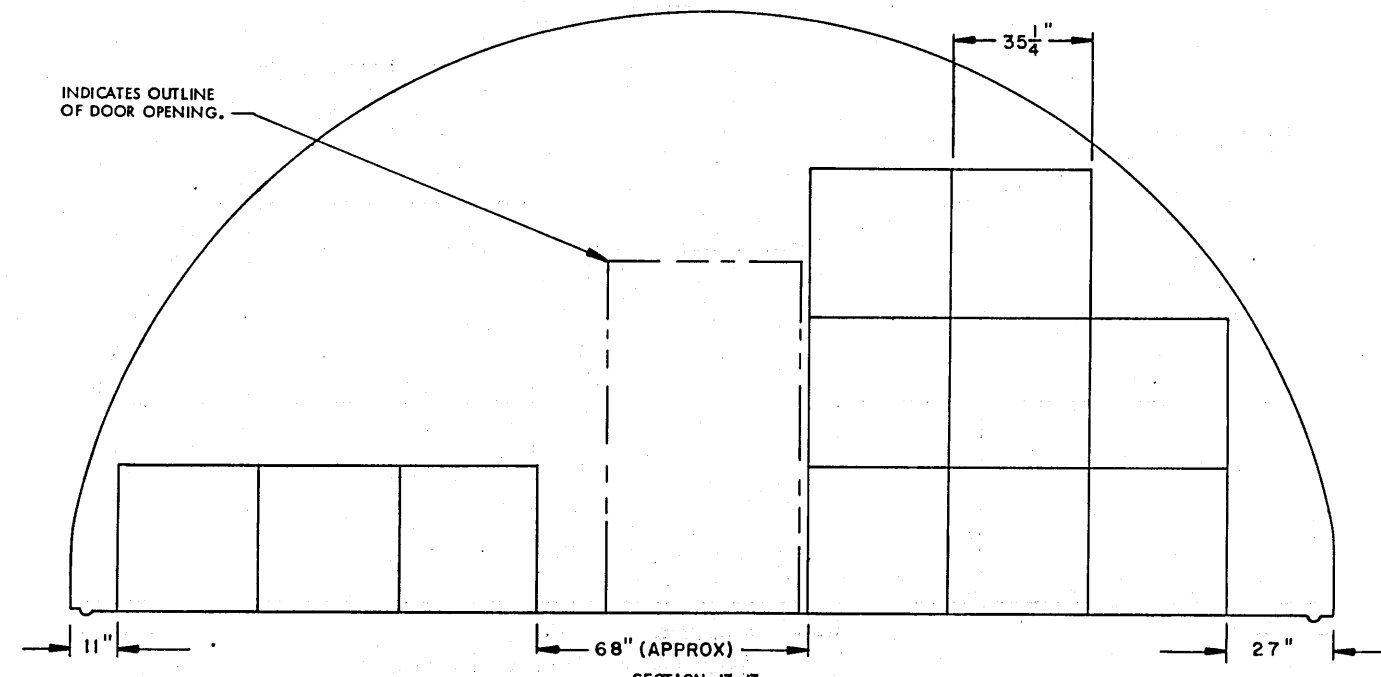
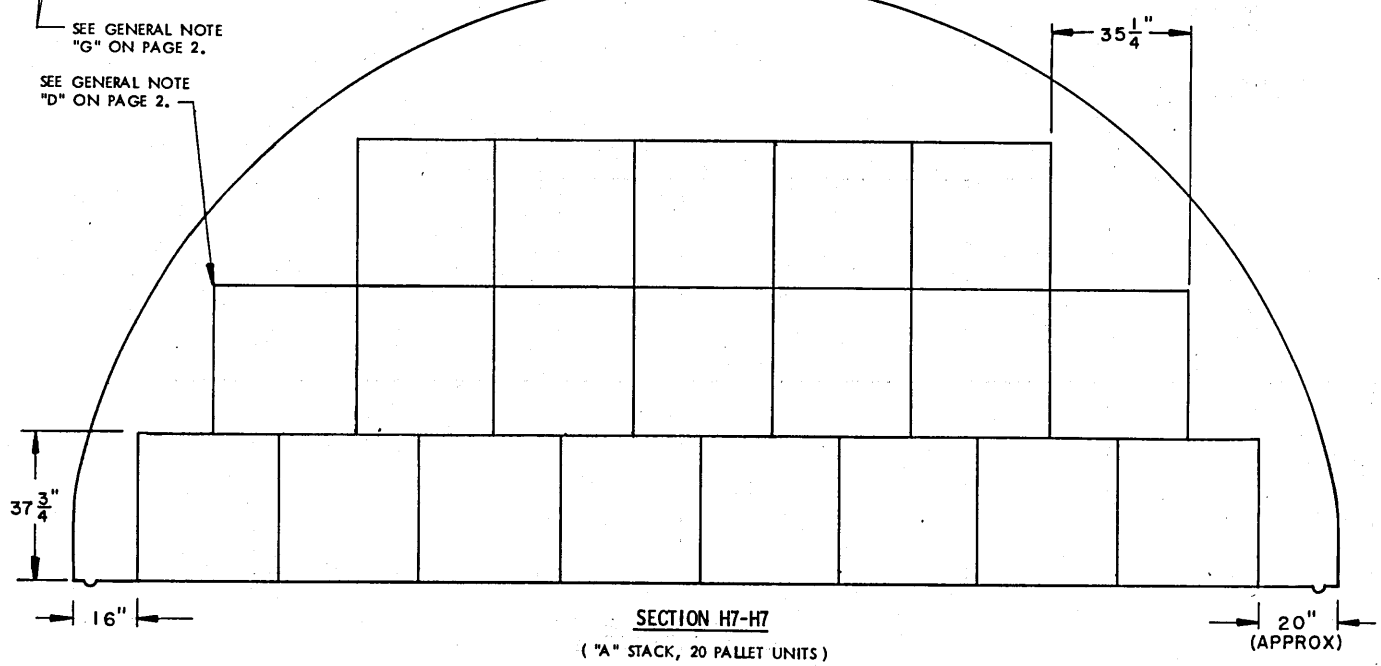

STORAGE PROCEDURES FOR UNIT NO. 61 (DECREASED-HEIGHT UNIT)

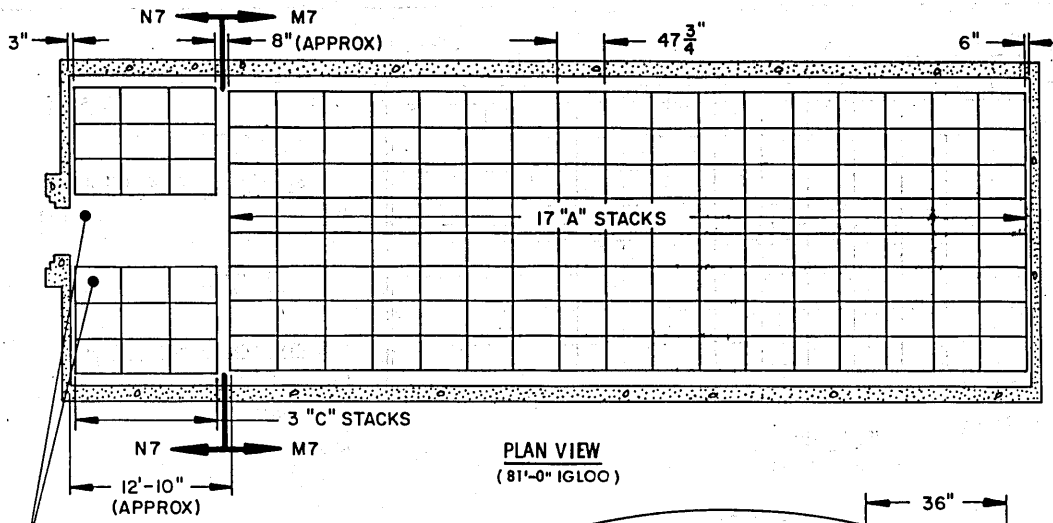

STORAGE IN 81'-0" IGLOO	
ITEM	QUANTITY
PALLET UNITS	262
* STORAGE IN 60'-8" IGLOO	
ITEM	QUANTITY
PALLET UNITS	184
* 12 A-STACKS	
2 C-STACKS	
** STORAGE IN 40'-4" IGLOO	
ITEM	QUANTITY
PALLET UNITS	114
** 7 A-STACKS	
2 C-STACKS	

SEE GENERAL NOTE "G" ON PAGE 2.

SEE GENERAL NOTE "D" ON PAGE 2.

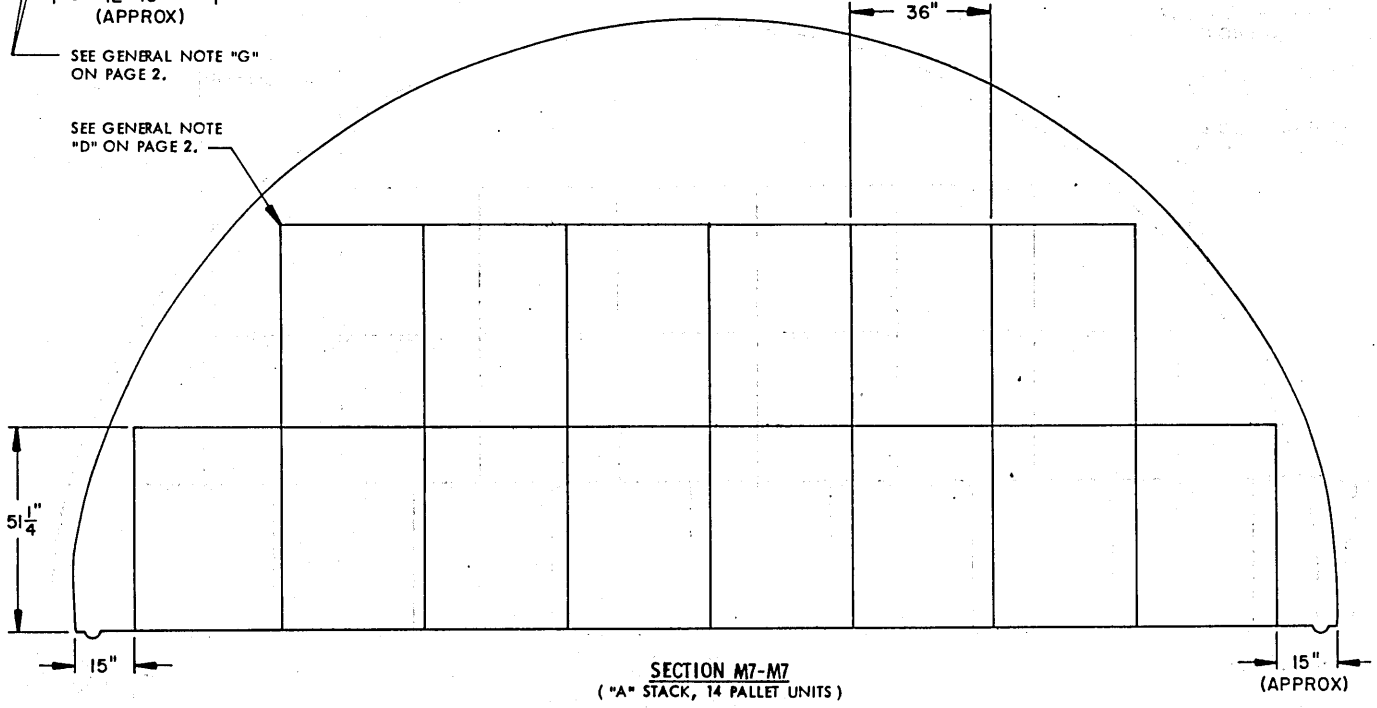

INDICATES OUTLINE OF DOOR OPENING,

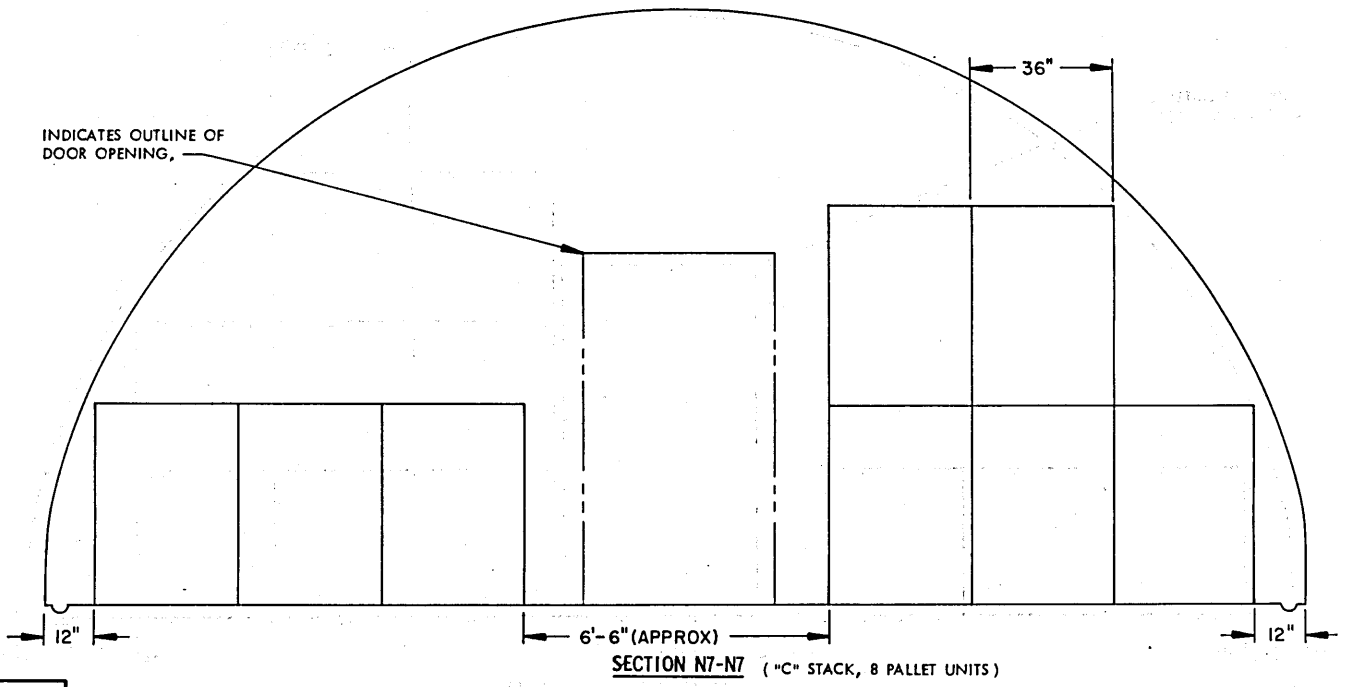

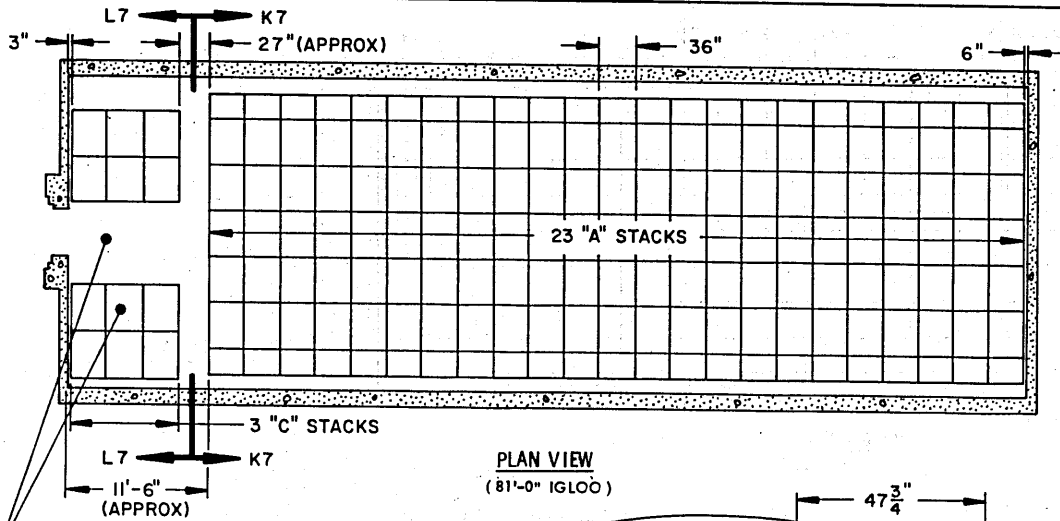

ITEM	QUANTITY
PALLET UNITS	343

* STORAGE IN 60'-8" IGLOO

ITEM	QUANTITY
PALLET UNITS	245
* 16 A-STACKS	
3 C-STACKS	

** STORAGE IN 40'-4" IGLOO

ITEM	QUANTITY
PALLET UNITS	154
** 9 A-STACKS	
4 C-STACKS	

SEE GENERAL NOTE "G" ON PAGE 2.

SEE GENERAL NOTE "D" ON PAGE 2.

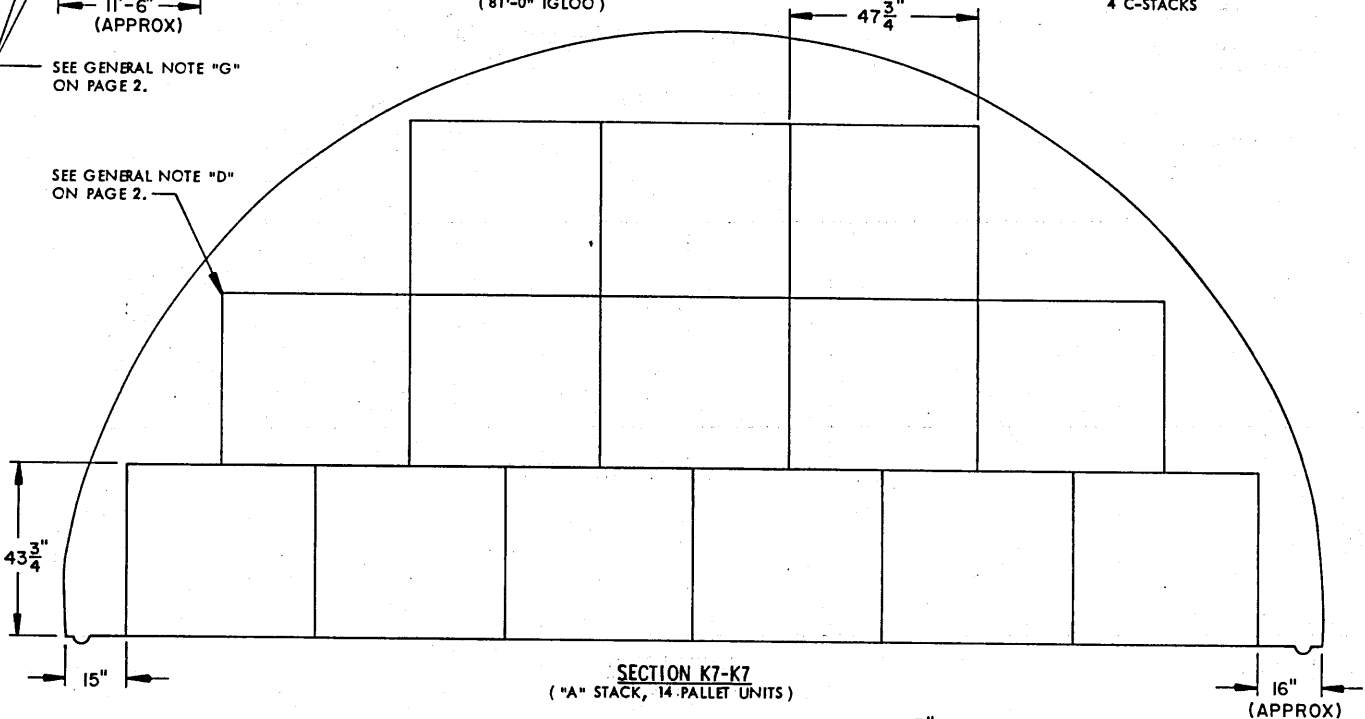

INDICATES OUTLINE OF DOOR OPENING.

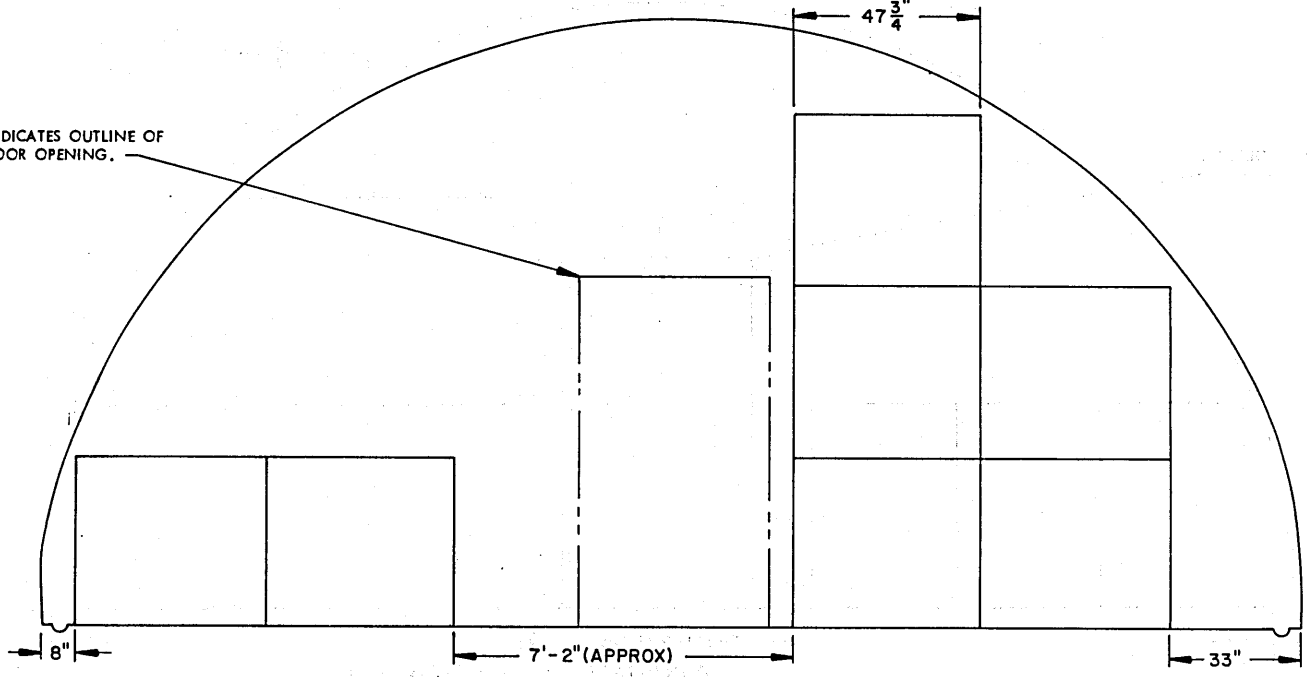

STORAGE PROCEDURES FOR UNIT NO. 62 (DECREASED-HEIGHT UNIT)

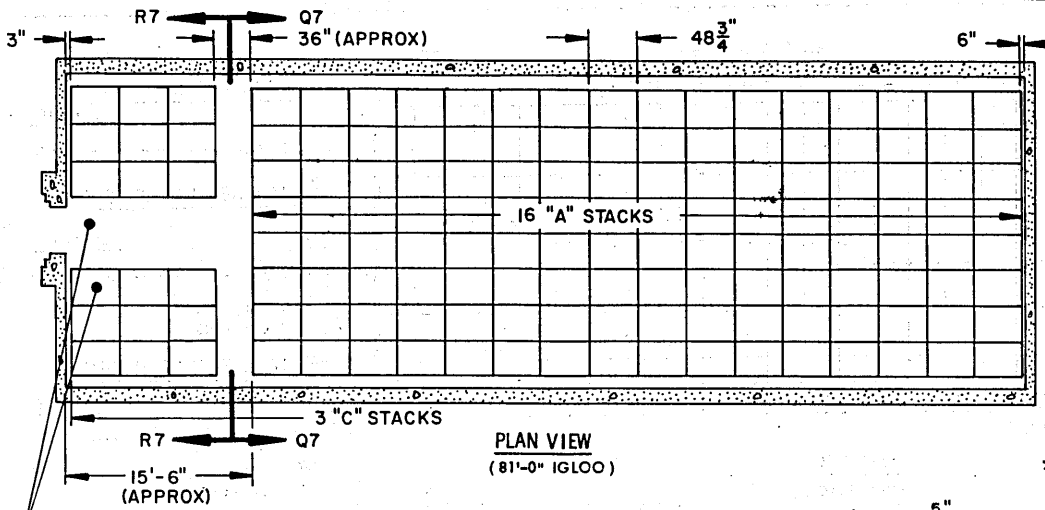

STORAGE IN 81'-0" IGLOO	
ITEM	QUANTITY
PALLET UNITS	248
* STORAGE IN 60'-8" IGLOO	
ITEM	QUANTITY
PALLET UNITS	178
* 11 A-STACKS	
3 C-STACKS	
** STORAGE IN 40'-4" IGLOO	
ITEM	QUANTITY
PALLET UNITS	108
** 6 A-STACKS	
3 C-STACKS	

SEE GENERAL NOTE "G"
ON PAGE 2.

SEE GENERAL NOTE "D"
ON PAGE 2.

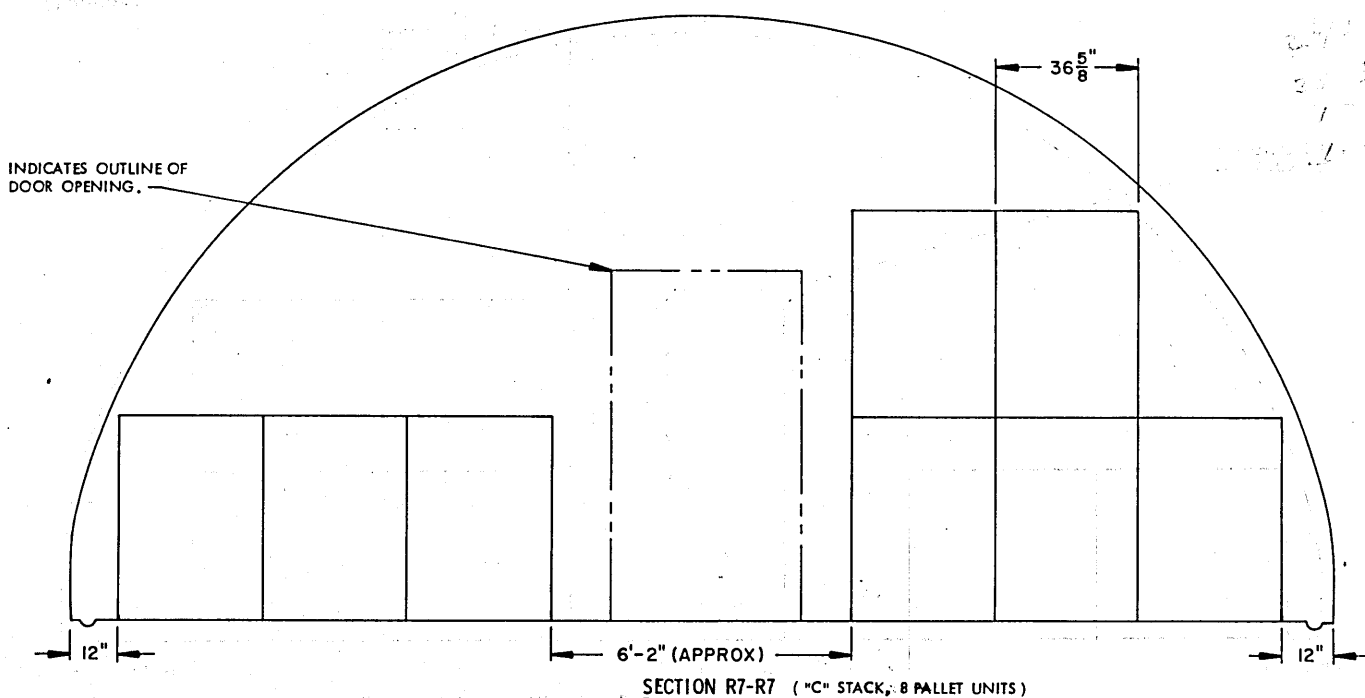
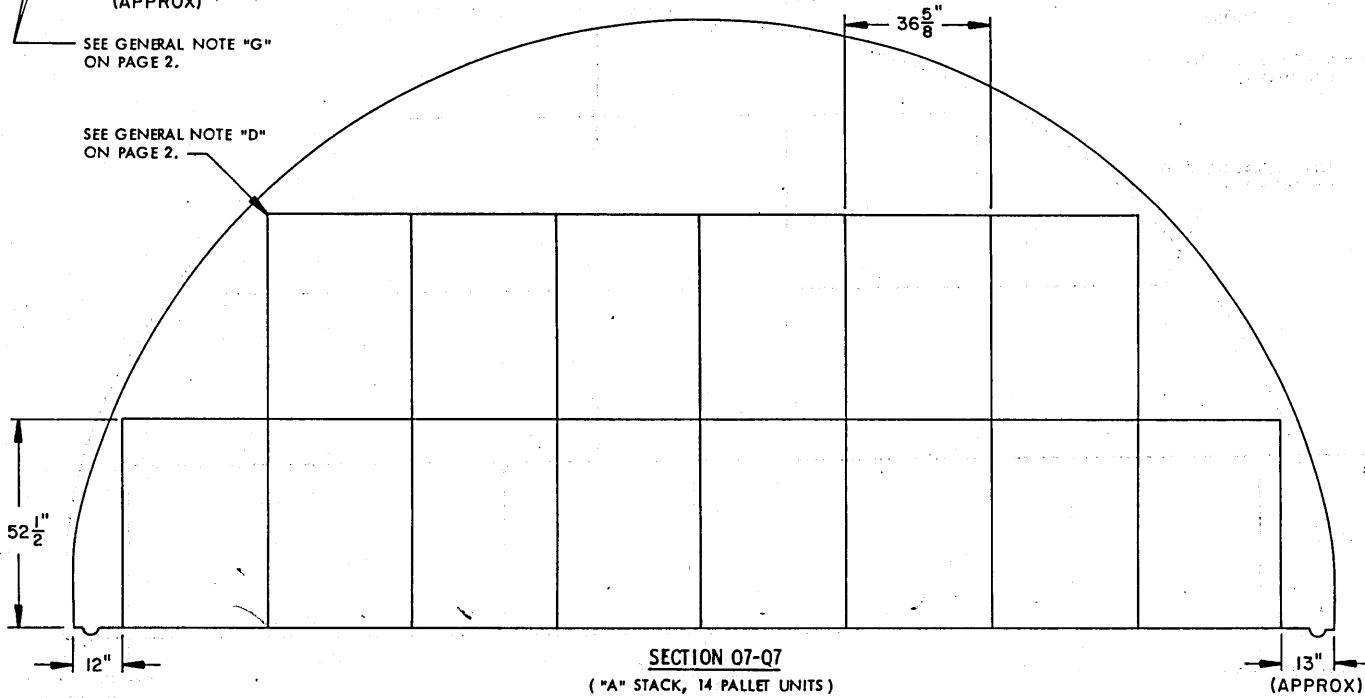

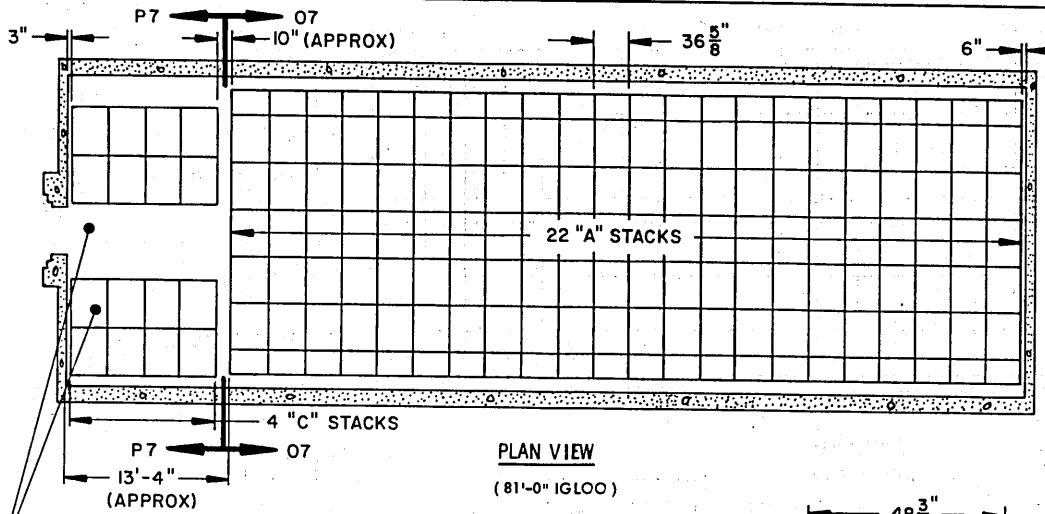

STORAGE IN 81'-0" IGLOO

ITEM	QUANTITY
PALLET UNITS	336

*** STORAGE IN 60'-8" IGLOO**

ITEM	QUANTITY
PALLET UNITS	245

- * 16 A-STACKS
- 3 C-STACKS

**** STORAGE IN 40'-4" IGLOO**

ITEM	QUANTITY
PALLET UNITS	147

- ** 9 A-STACKS
- 3 C-STACKS

SEE GENERAL NOTE "G" ON PAGE 2.

SEE GENERAL NOTE "D" ON PAGE 2.

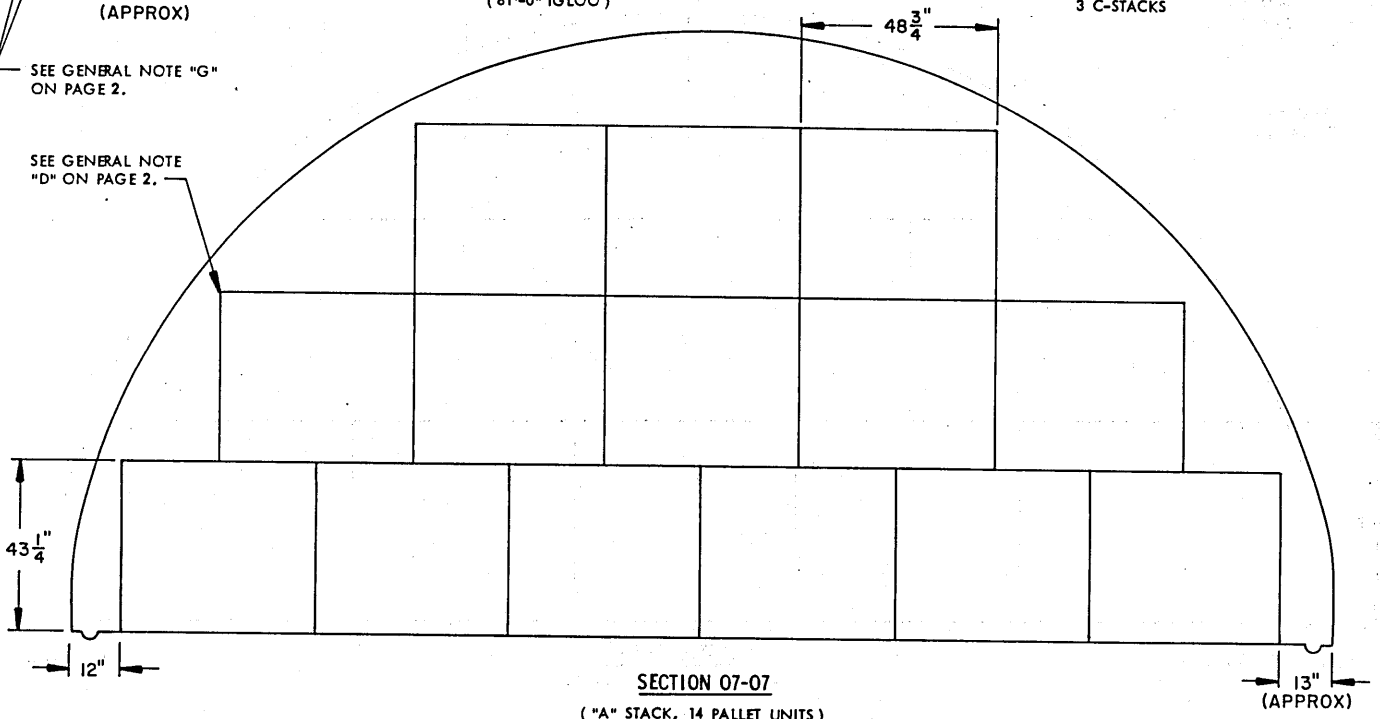

INDICATES OUTLINE OF DOOR OPENING.

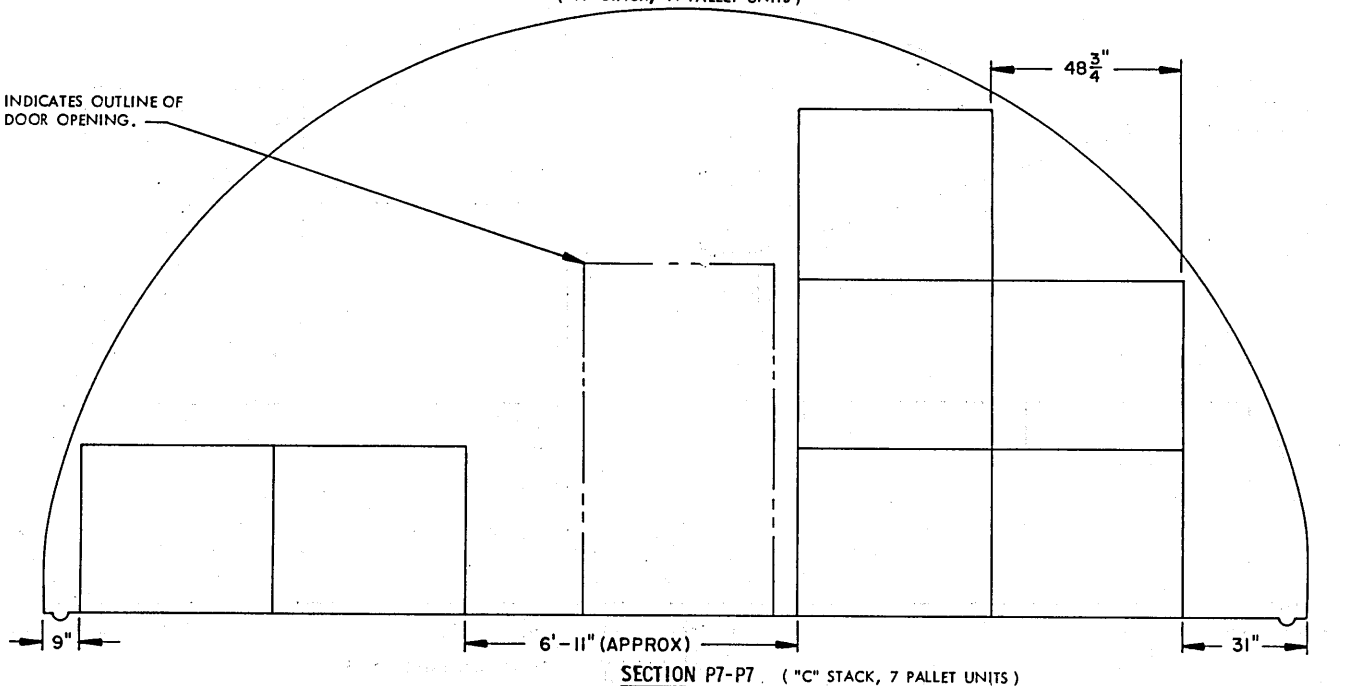

STORAGE PROCEDURES FOR UNIT NO. 63 (DECREASED-HEIGHT UNIT)

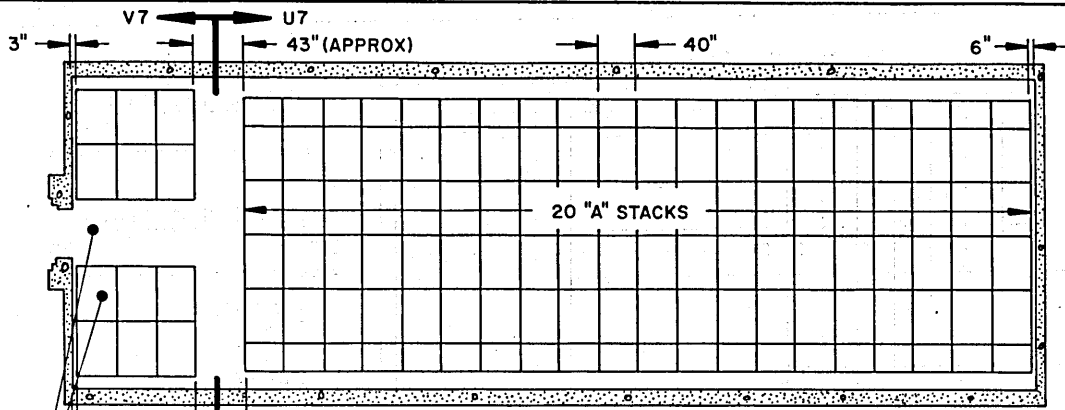

PLAN VIEW
(81'-0" IGLOO)

STORAGE IN 81'-0" IGLOO	
ITEM	QUANTITY
PALLET UNITS	195
* STORAGE IN 60'-8" IGLOO	
ITEM	QUANTITY
PALLET UNITS	141
14 A-STACKS	
3 C-STACKS	
** STORAGE IN 40'-4" IGLOO	
ITEM	QUANTITY
PALLET UNITS	87
8 A-STACKS	
3 C-STACKS	

SEE GENERAL NOTE "G" ON PAGE 2.

SEE GENERAL NOTE "D" ON PAGE 2.

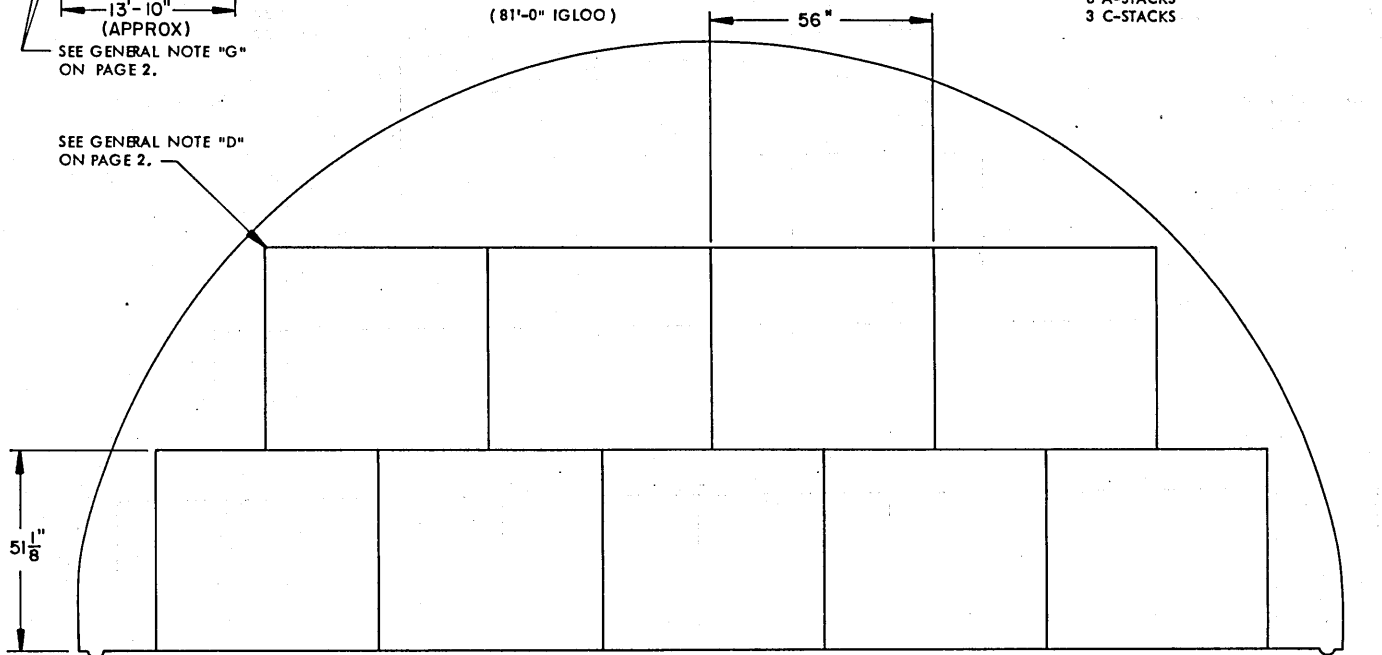

SECTION U7-U7
(*A" STACK, 9 PALLET UNITS)

INDICATES OUTLINE OF DOOR OPENING.

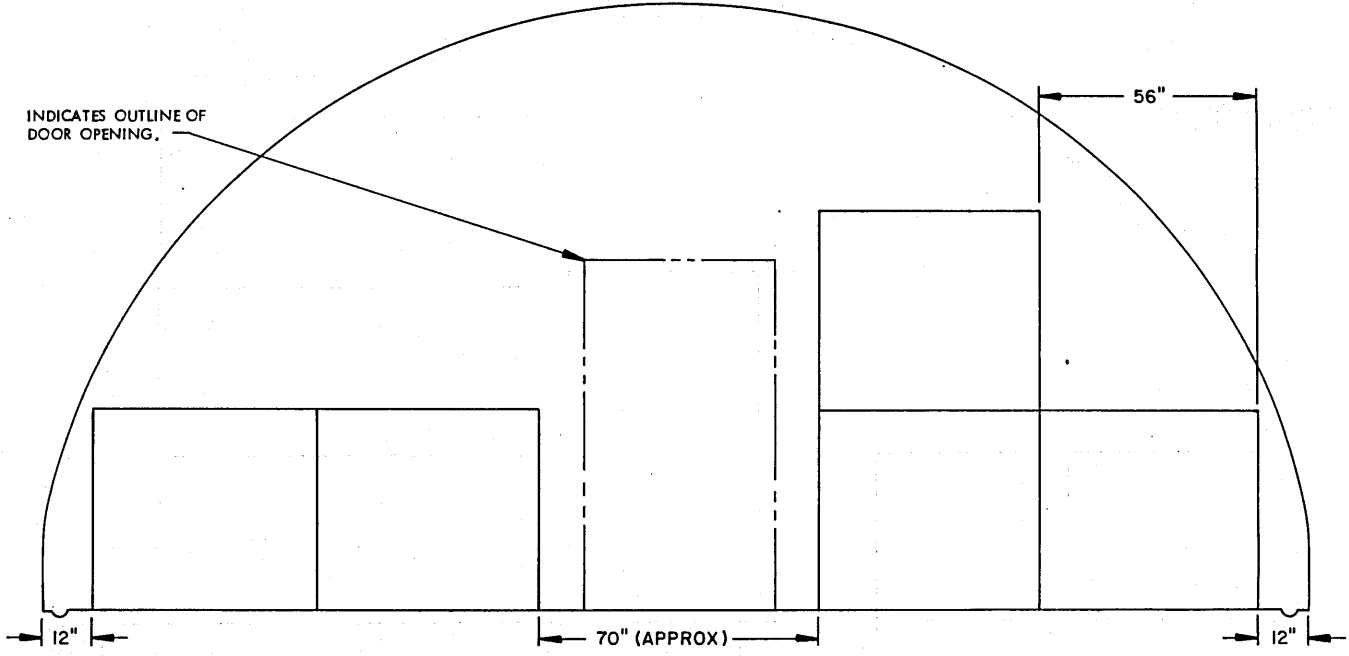

SECTION V7-V7 ("C" STACK, 5 PALLET UNITS)

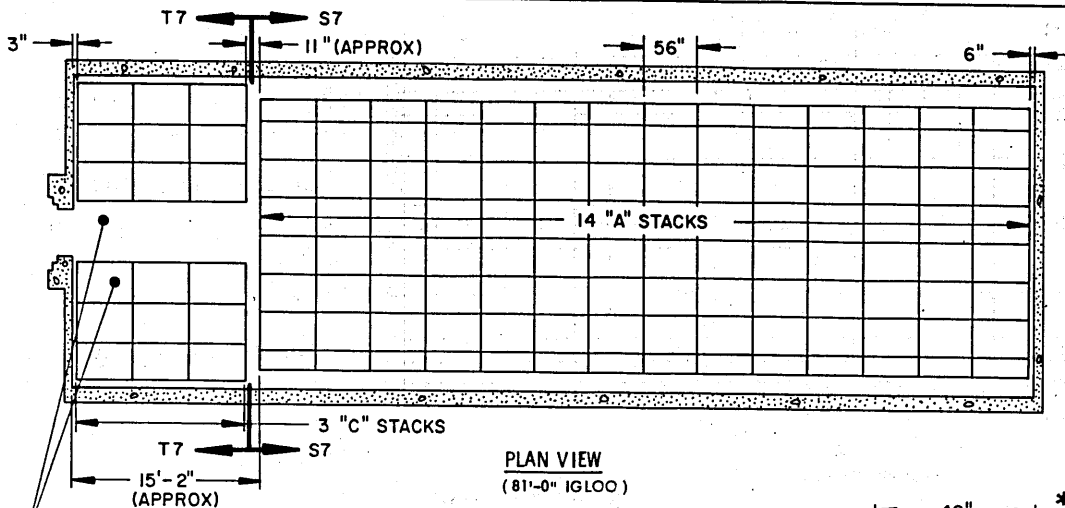

PLAN VIEW
(81'-0" IGLOO)

STORAGE IN 81'-0" IGLOO	
ITEM	QUANTITY
PALLET UNITS	265
* STORAGE IN 60'-8" IGLOO	
ITEM	QUANTITY
PALLET UNITS	188
10 A-STACKS	
2 C-STACKS	
** STORAGE IN 40'-4" IGLOO	
ITEM	QUANTITY
PALLET UNITS	112
5 A-STACKS	
3 C-STACKS	

SEE GENERAL NOTE "G" ON PAGE 2.

SEE GENERAL NOTE "D" ON PAGE 2.

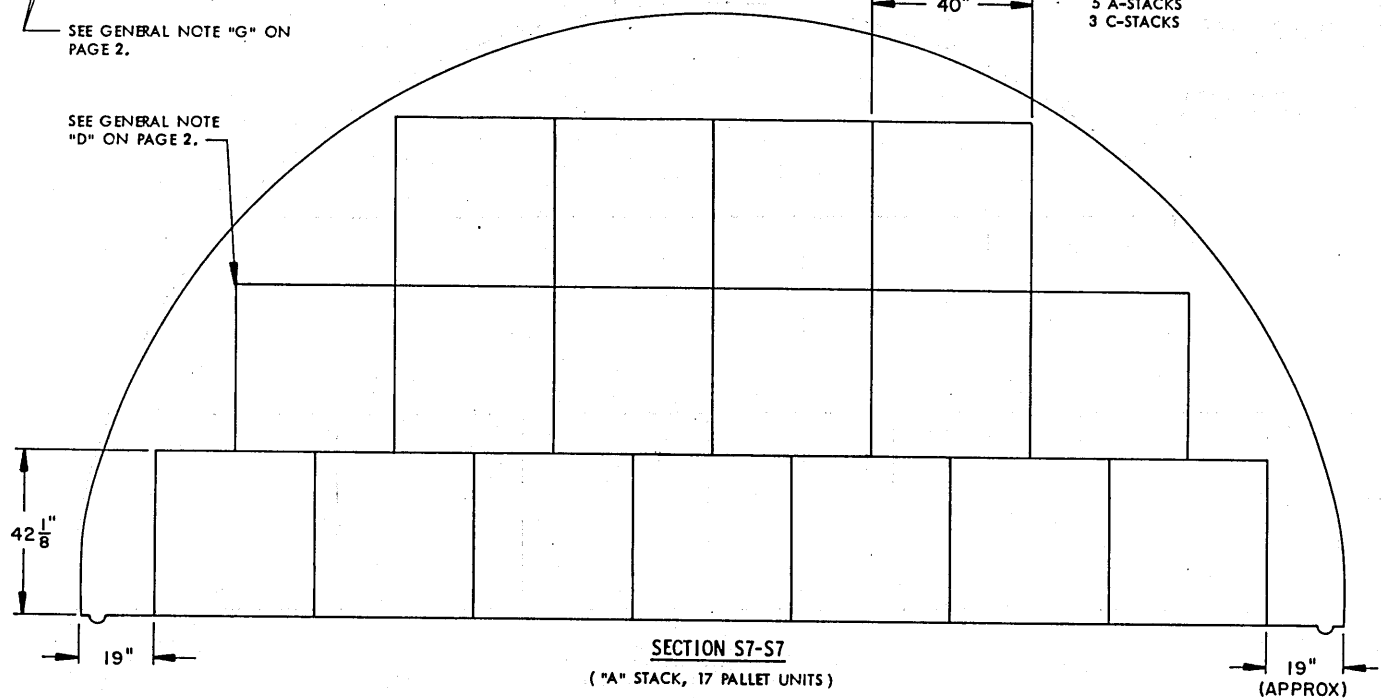

SECTION S7-S7
("A" STACK, 17 PALLET UNITS)

INDICATES OUTLINE OF DOOR OPENING.

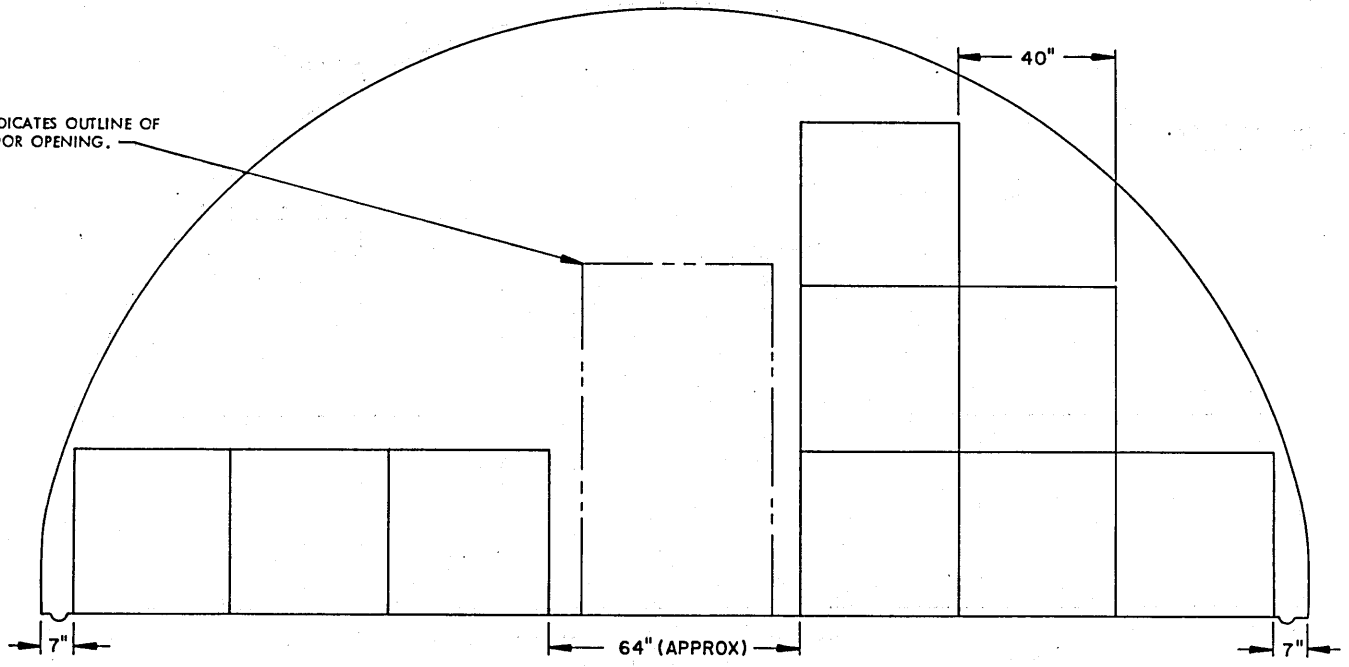

SECTION T7-T7 ("C" STACK, 9 PALLET UNITS)

STORAGE PROCEDURES FOR UNIT NO. 64 (DECREASED-HEIGHT UNIT)

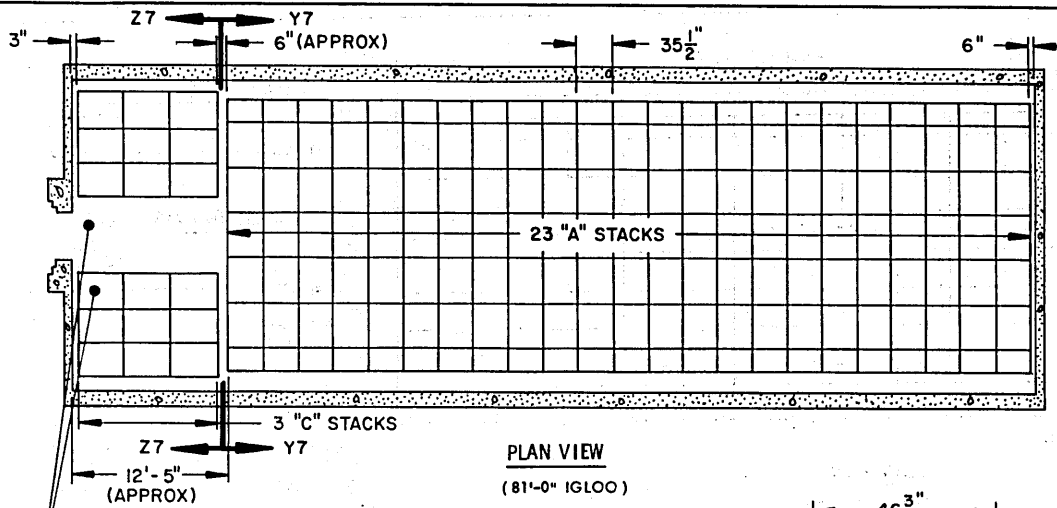

STORAGE IN 81'-0' IGLOO	
ITEM	QUANTITY
PALLET UNITS	277
* STORAGE IN 60'-8' IGLOO	
ITEM	QUANTITY
PALLET UNITS	200
* 16 A-STACKS	
3 C-STACKS	
** STORAGE IN 40'-0' IGLOO	
ITEM	QUANTITY
PALLET UNITS	123
** 9 A-STACKS	
3 C-STACKS	

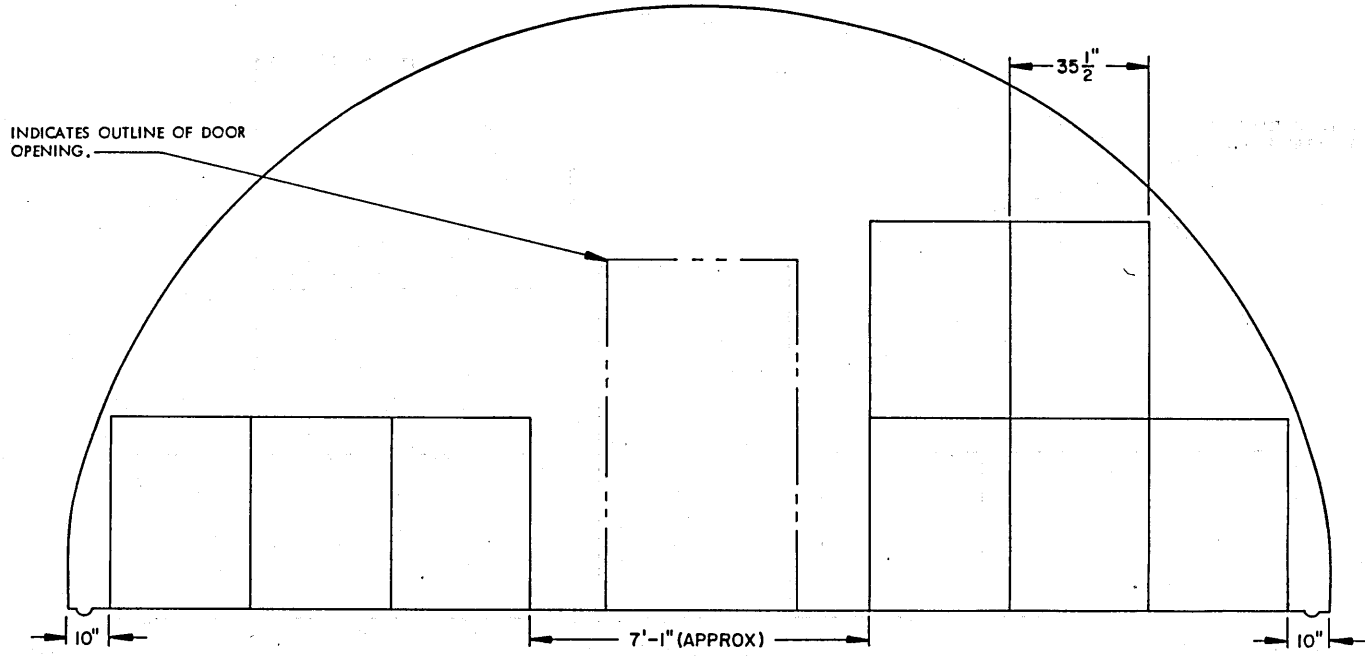
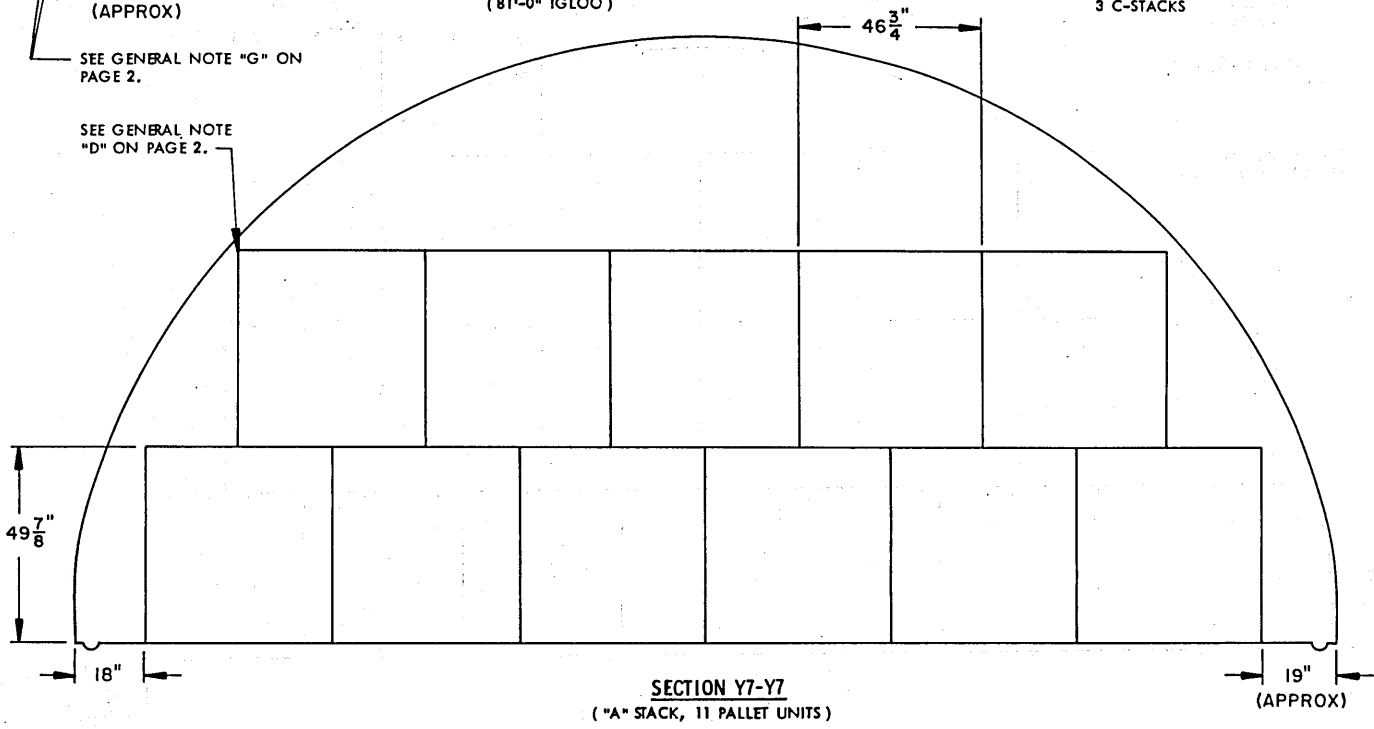

SEE GENERAL NOTE "G" ON PAGE 2.

SEE GENERAL NOTE "D" ON PAGE 2.

INDICATES OUTLINE OF DOOR OPENING.

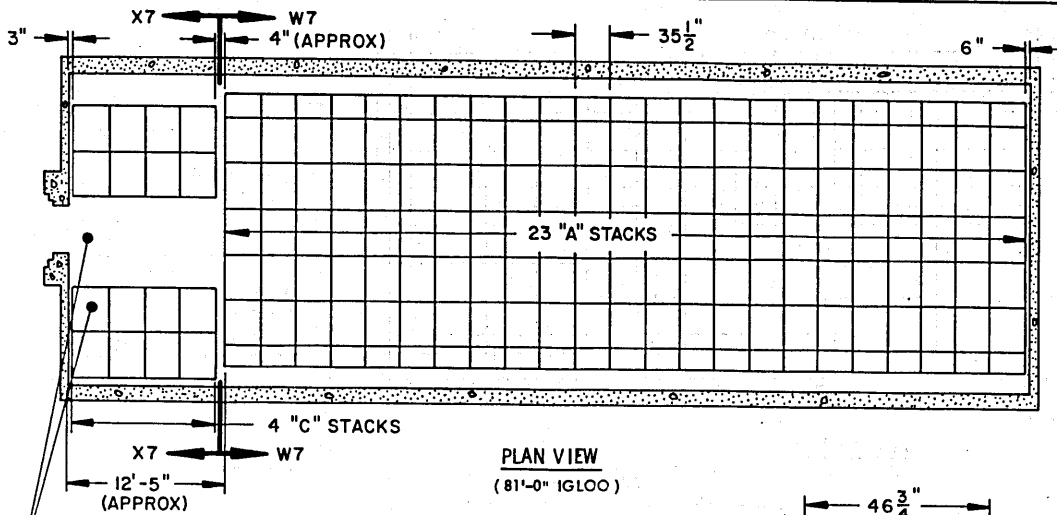

PLAN VIEW (81'-0" IGLOO)

STORAGE IN 81'-0" IGLOO

ITEM	QUANTITY
PALLET UNITS	350

* STORAGE IN 60'-8" IGLOO

ITEM	QUANTITY
PALLET UNITS	252

- * 16 A-STACKS
- 4 C-STACKS

** STORAGE IN 40'-4" IGLOO

ITEM	QUANTITY
PALLET UNITS	154

- ** 9 A-STACKS
- 4 C-STACKS

SEE GENERAL NOTE "G" ON PAGE 2.

SEE GENERAL NOTE "D" ON PAGE 2.

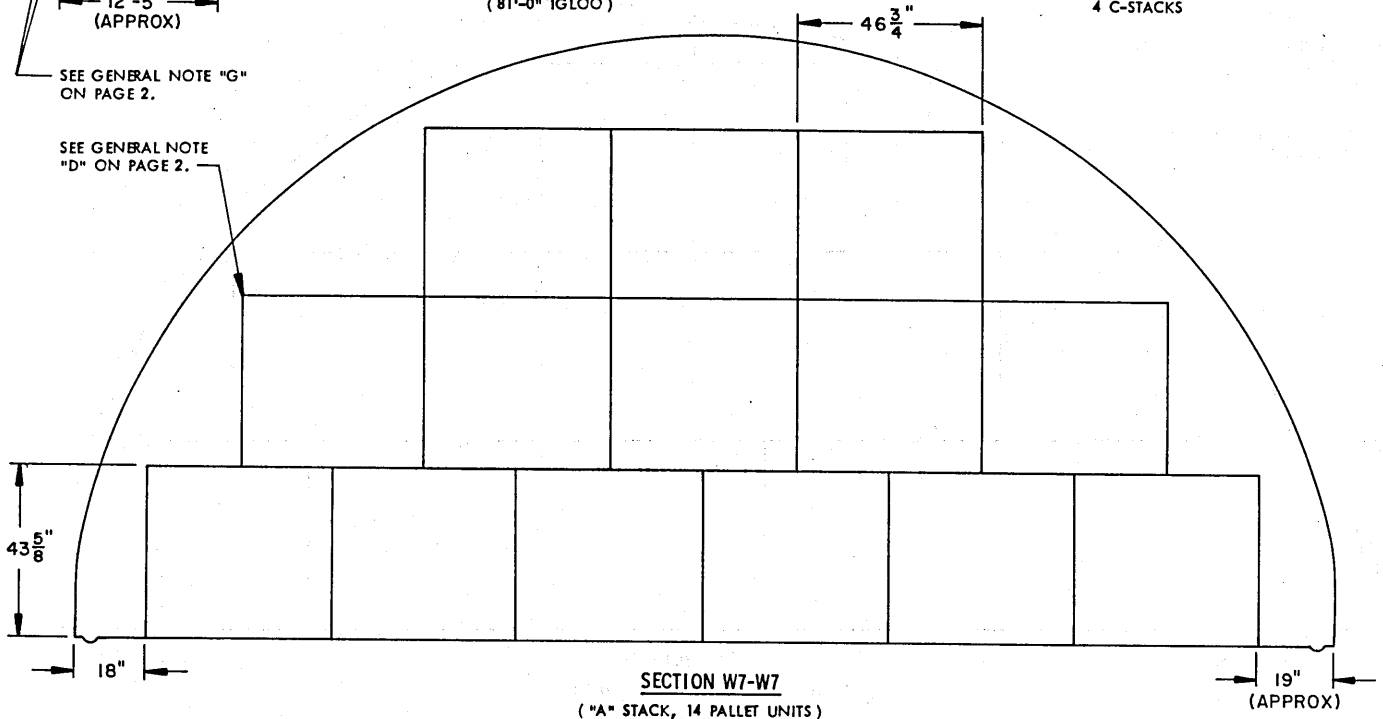

SECTION W7-W7 ("A" STACK, 14 PALLET UNITS)

INDICATES OUTLINE OF DOOR OPENING.

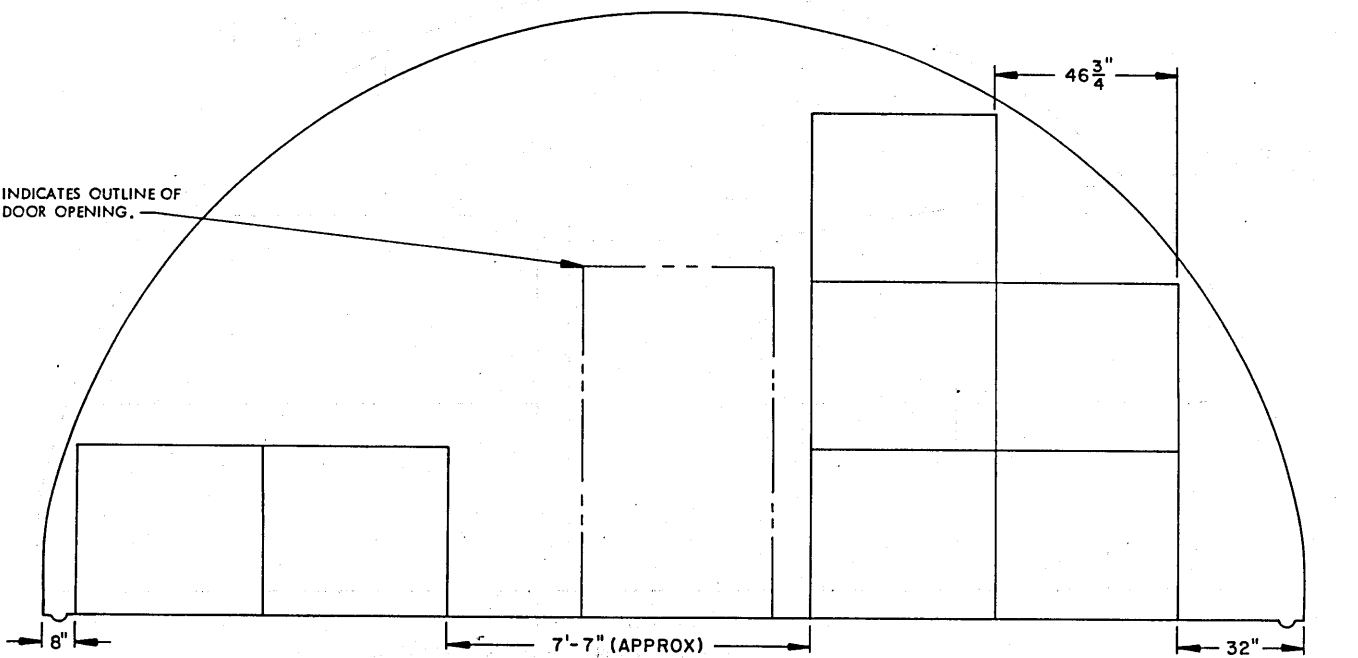

SECTION X7-X7 ("C" STACK, 7 PALLET UNITS)

STORAGE PROCEDURES FOR UNIT NO. 65 (DECREASED-HEIGHT UNIT).

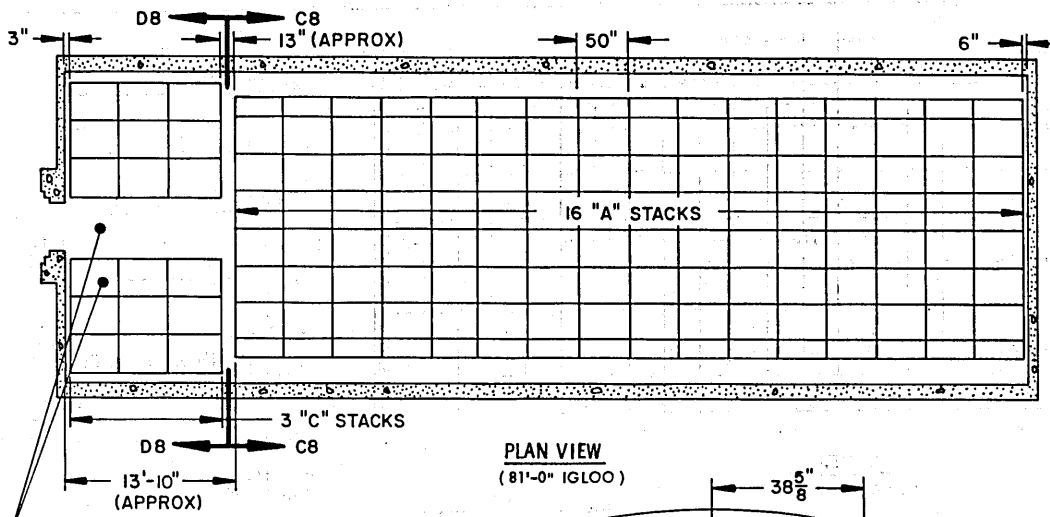

PLAN VIEW
(81'-0" IGLOO)

STORAGE IN 81'-0" IGLOO	
ITEM	QUANTITY
PALLET UNITS	264
* STORAGE IN 60'-8" IGLOO	
ITEM	QUANTITY
PALLET UNITS	189
* 11 A-STACKS	
3 C-STACKS	
** STORAGE IN 40'-4" IGLOO	
ITEM	QUANTITY
PALLET UNITS	114
** 6 A-STACKS	
3 C-STACKS	

SEE GENERAL NOTE "G" ON PAGE 2.

SEE GENERAL NOTE "D" ON PAGE 2.

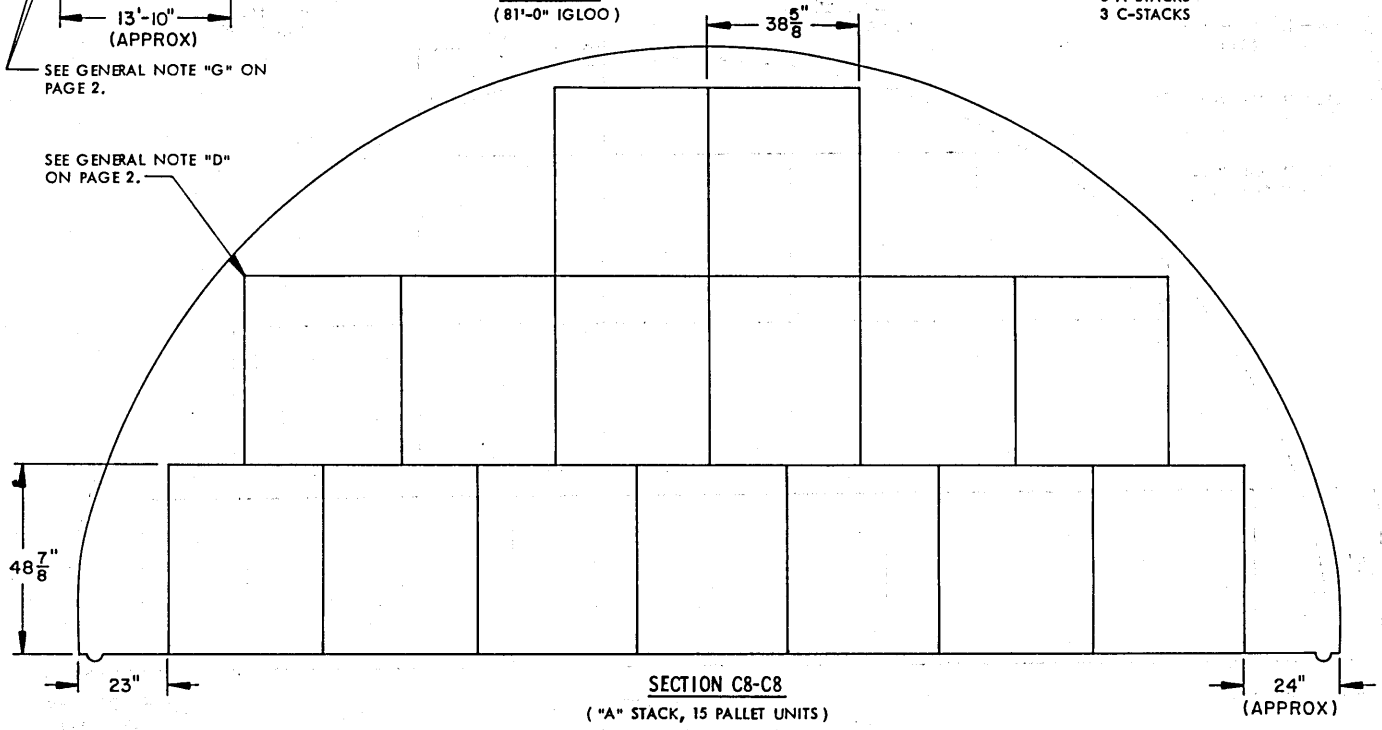

SECTION C8-C8
("A" STACK, 15 PALLET UNITS)

INDICATES OUTLINE OF DOOR OPENING.

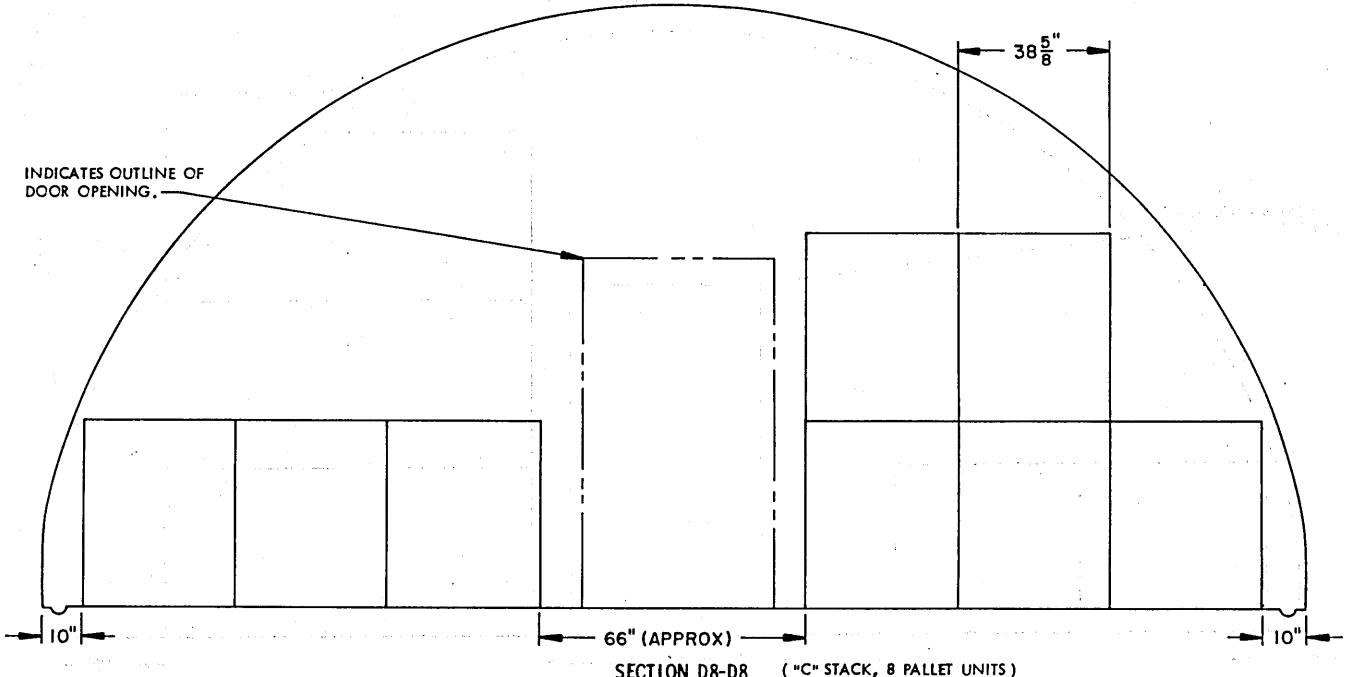

SECTION D8-D8 ("C" STACK, 8 PALLET UNITS)

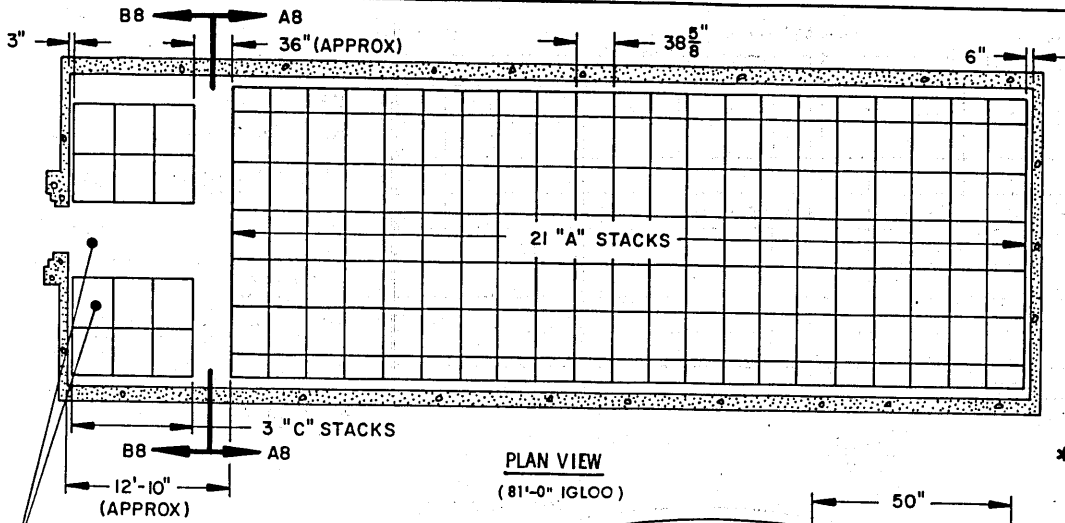

STORAGE IN 81'-0" IGLOO	
ITEM	QUANTITY
PALLET UNITS	315
* STORAGE IN 60'-8" IGLOO	
ITEM	QUANTITY
PALLET UNITS	231
15 A-STACKS	
3 C-STACKS	
*** STORAGE IN 40'-4" IGLOO	
ITEM	QUANTITY
PALLET UNITS	140
8 A-STACKS	
4 C-STACKS	

SEE GENERAL NOTE "G" ON PAGE 2.

SEE GENERAL NOTE "D" ON PAGE 2.

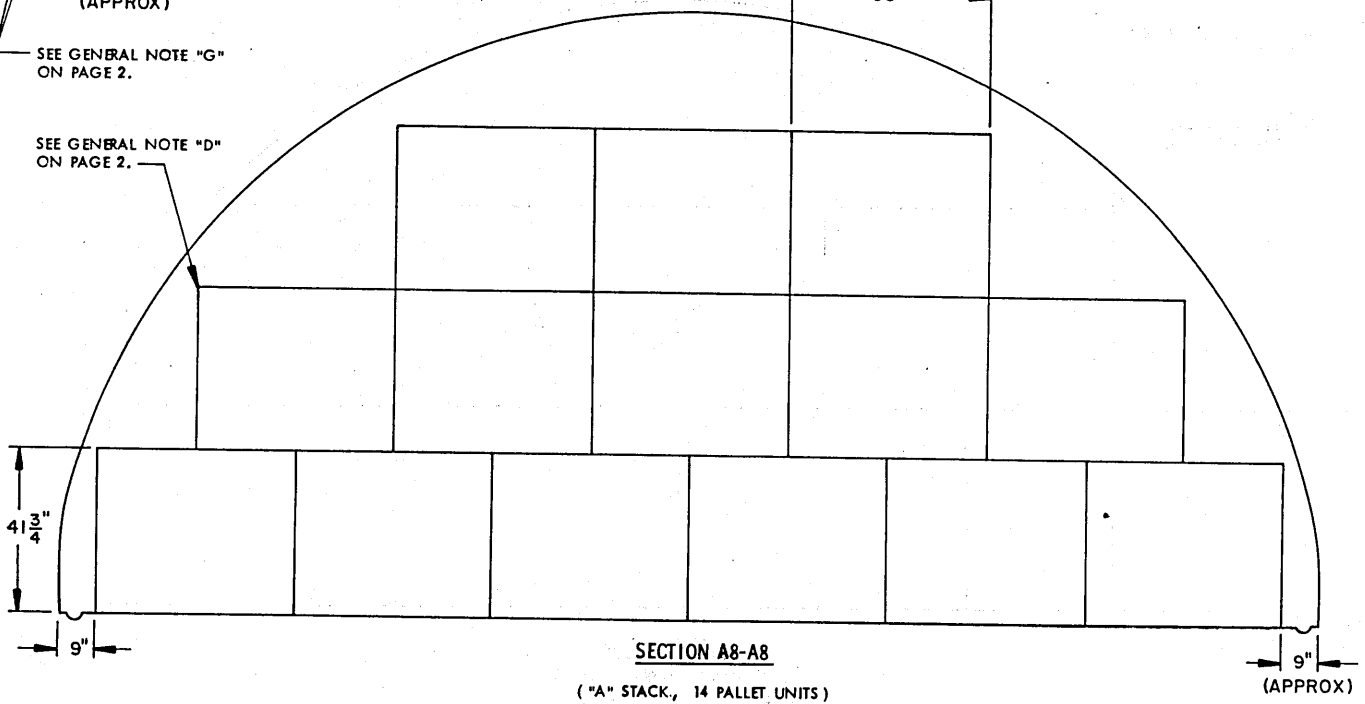

INDICATES OUTLINE OF DOOR OPENING.

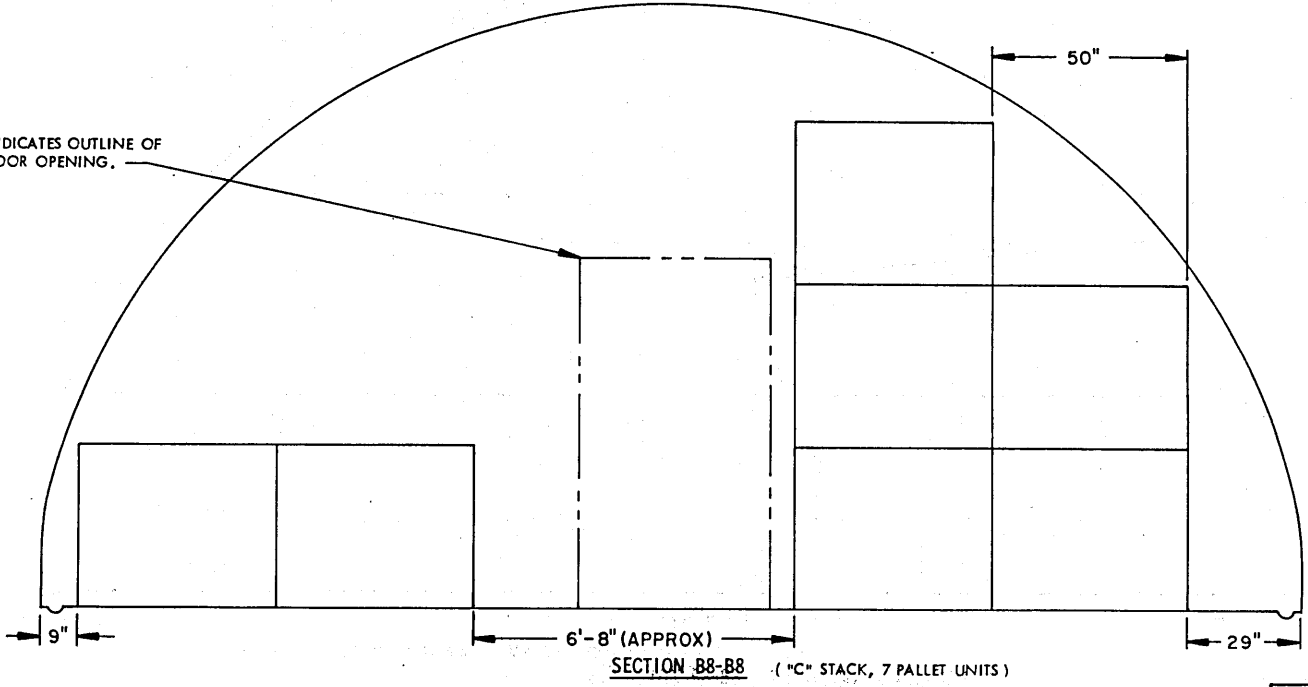

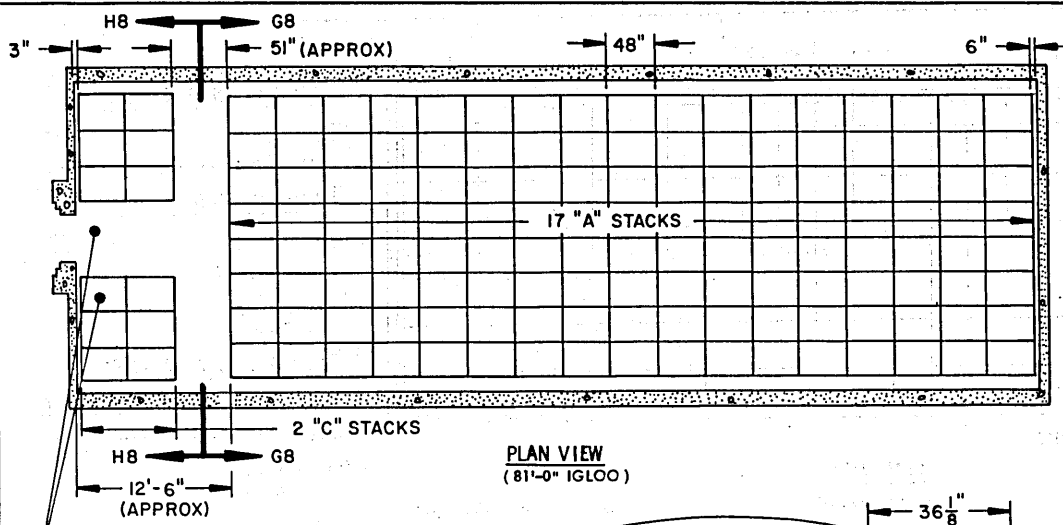

PLAN VIEW
(81'-0" IGLOO)

STORAGE IN 81'-0" IGLOO	
ITEM	QUANTITY
PALLET UNITS	254
* STORAGE IN 60'-8" IGLOO	
ITEM	QUANTITY
PALLET UNITS	184
* 12 A-STACKS	
2 C-STACKS	
** STORAGE IN 40'-4" IGLOO	
ITEM	QUANTITY
PALLET UNITS	114
** 7 A-STACKS	
2 C-STACKS	

SEE GENERAL NOTE "G" ON PAGE 2.

SEE GENERAL NOTE "D" ON PAGE 2.

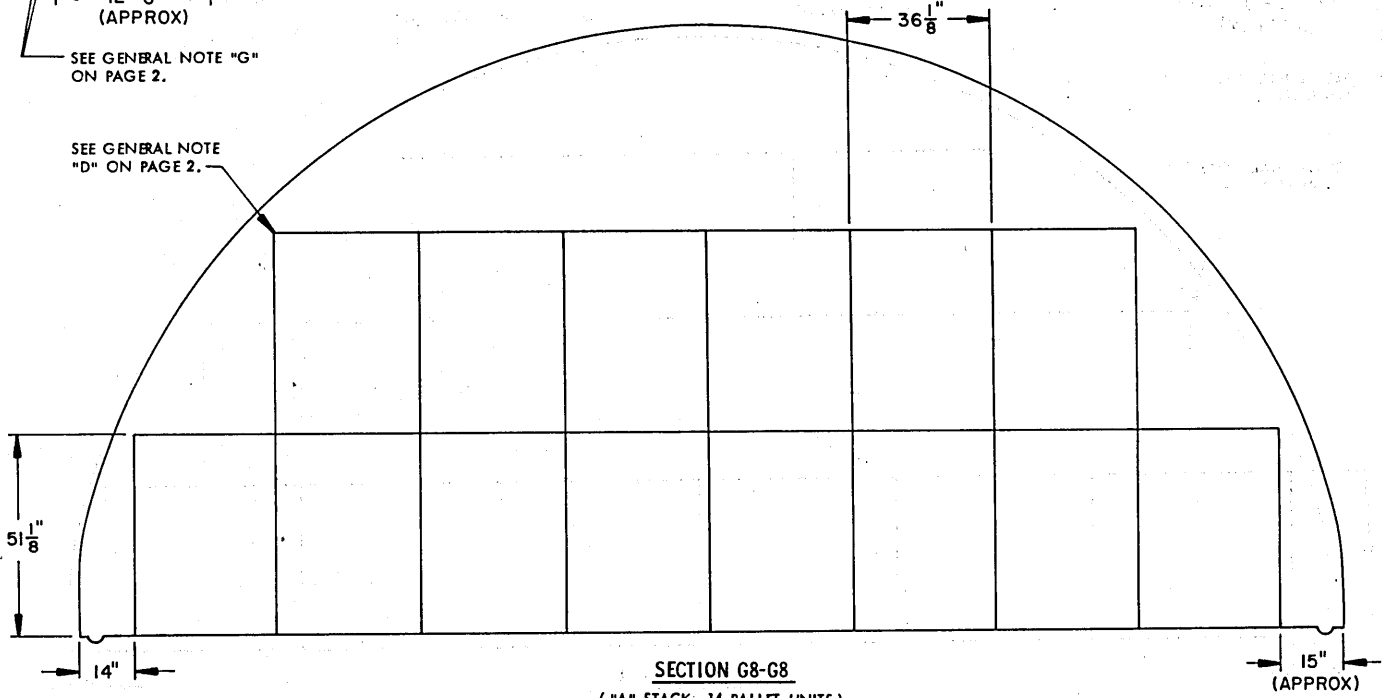

SECTION G8-G8
("A" STACK, 14 PALLET UNITS)

INDICATES OUTLINE OF DOOR OPENING.

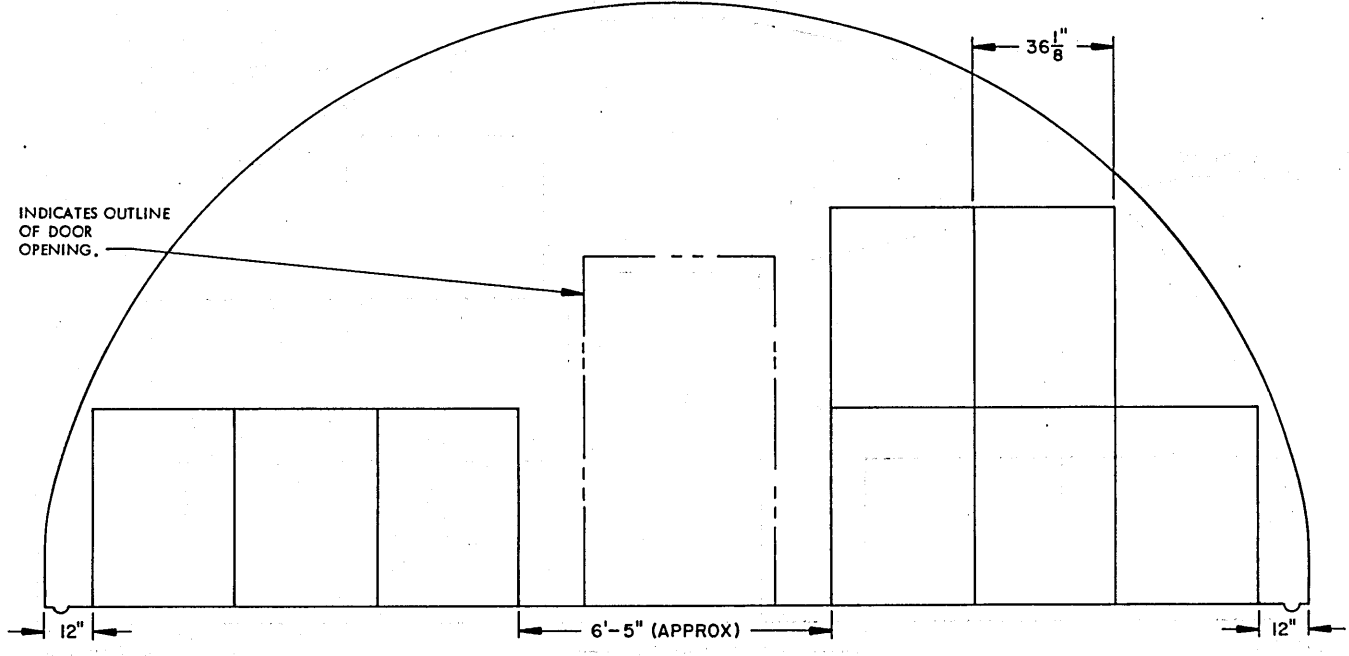

SECTION H8-H8 ("C" STACK, 8 PALLET UNITS)

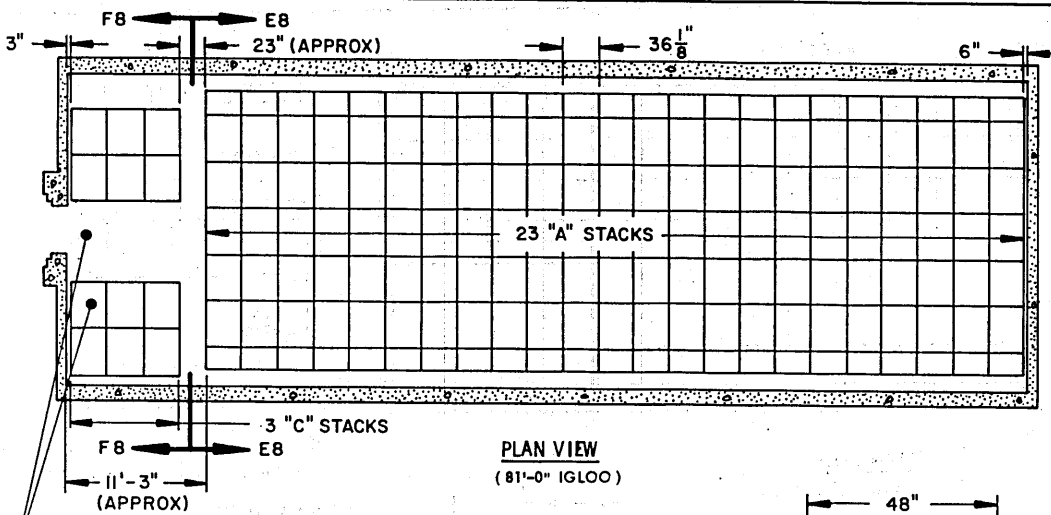

PLAN VIEW
(81'-0" IGLOO)

STORAGE IN 81'-0" IGLOO

ITEM	QUANTITY
PALLET UNITS	343

* STORAGE IN 60'-8" IGLOO

ITEM	QUANTITY
PALLET UNITS	245

- * 16 A-STACKS
- 3 C-STACKS

** STORAGE IN 40'-4" IGLOO

ITEM	QUANTITY
PALLET UNITS	154

- ** 9 A-STACKS
- 4 C-STACKS

SEE GENERAL NOTE "G" ON PAGE 2.

SEE GENERAL NOTE "D" ON PAGE 2.

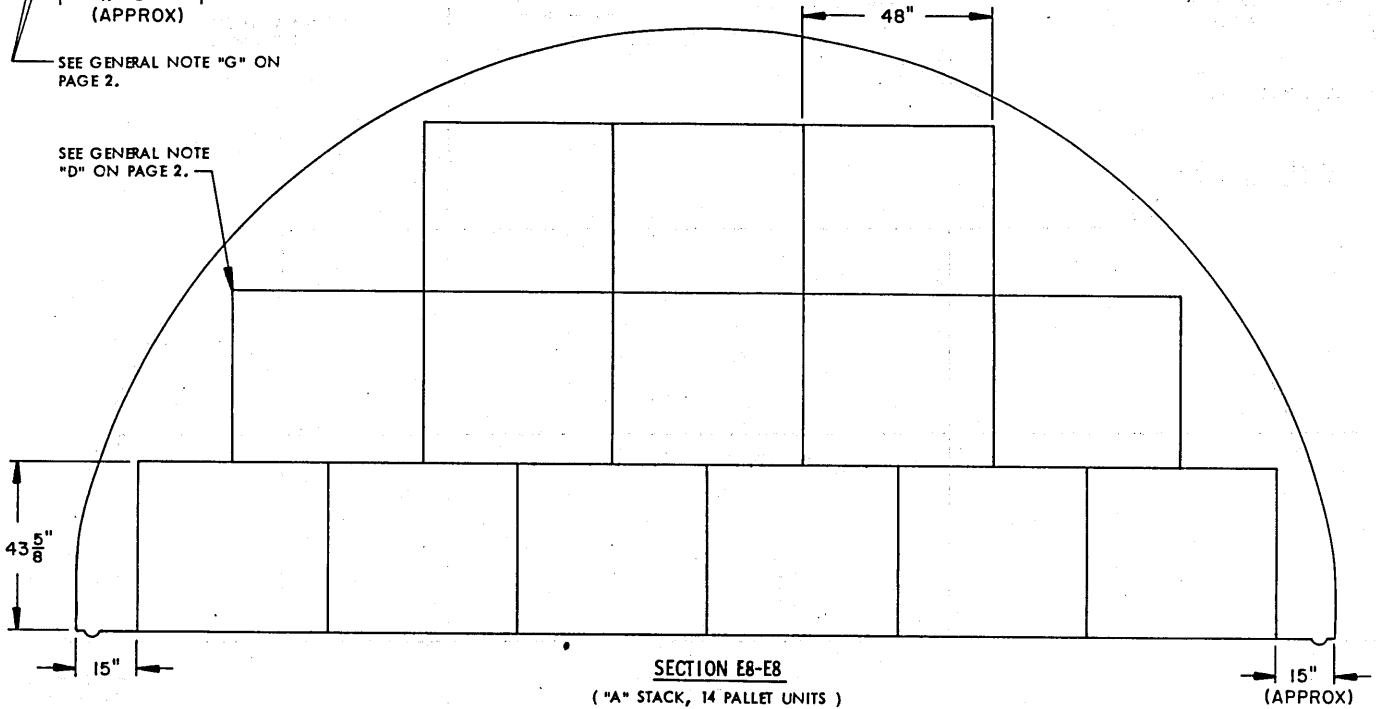

SECTION E8-E8
("A" STACK, 14 PALLET UNITS)

INDICATES OUTLINE OF DOOR OPENING.

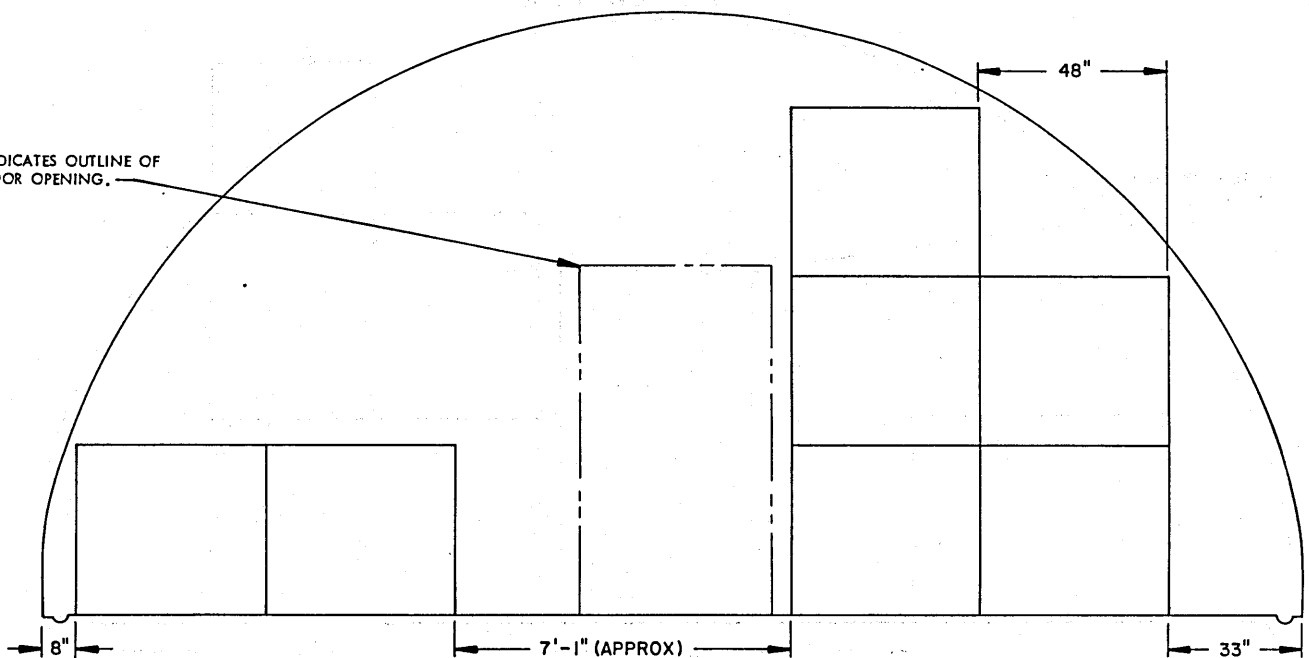

SECTION F8-F8 ("C" STACK, 7 PALLET UNITS)

STORAGE PROCEDURES FOR UNIT NO. 67 (DECREASED-HEIGHT UNIT)

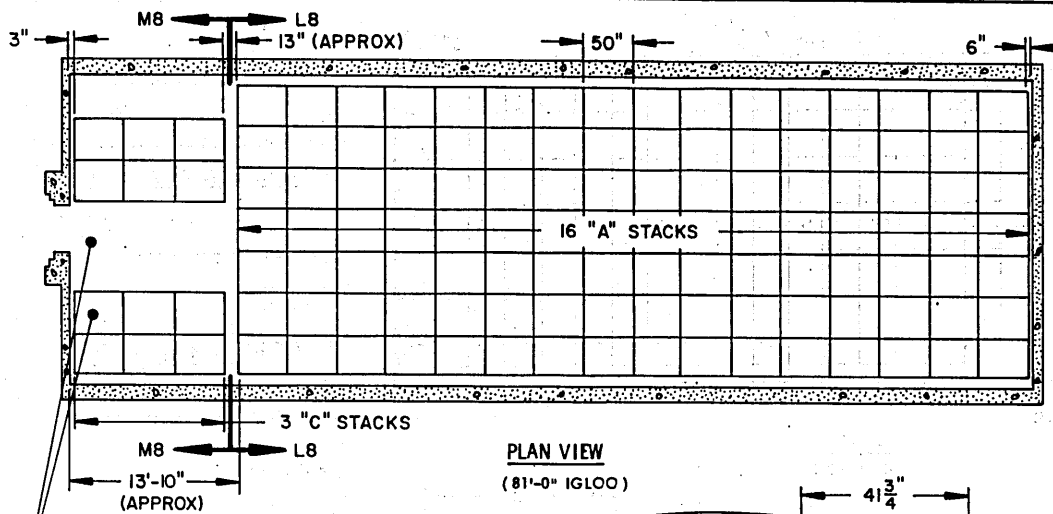

PLAN VIEW
(81'-0" IGLOO)

STORAGE IN 81'-0" IGLOO

ITEM	QUANTITY
PALLET UNITS	210

*** STORAGE IN 60'-8" IGLOO**

ITEM	QUANTITY
PALLET UNITS	150
* 11 A-STACKS	
3 C-STACKS	

**** STORAGE IN 40'-4" IGLOO**

ITEM	QUANTITY
PALLET UNITS	90
** 6 A-STACKS	
3 C-STACKS	

SEE GENERAL NOTE "G" ON PAGE 2.

SEE GENERAL NOTE "D" ON PAGE 2.

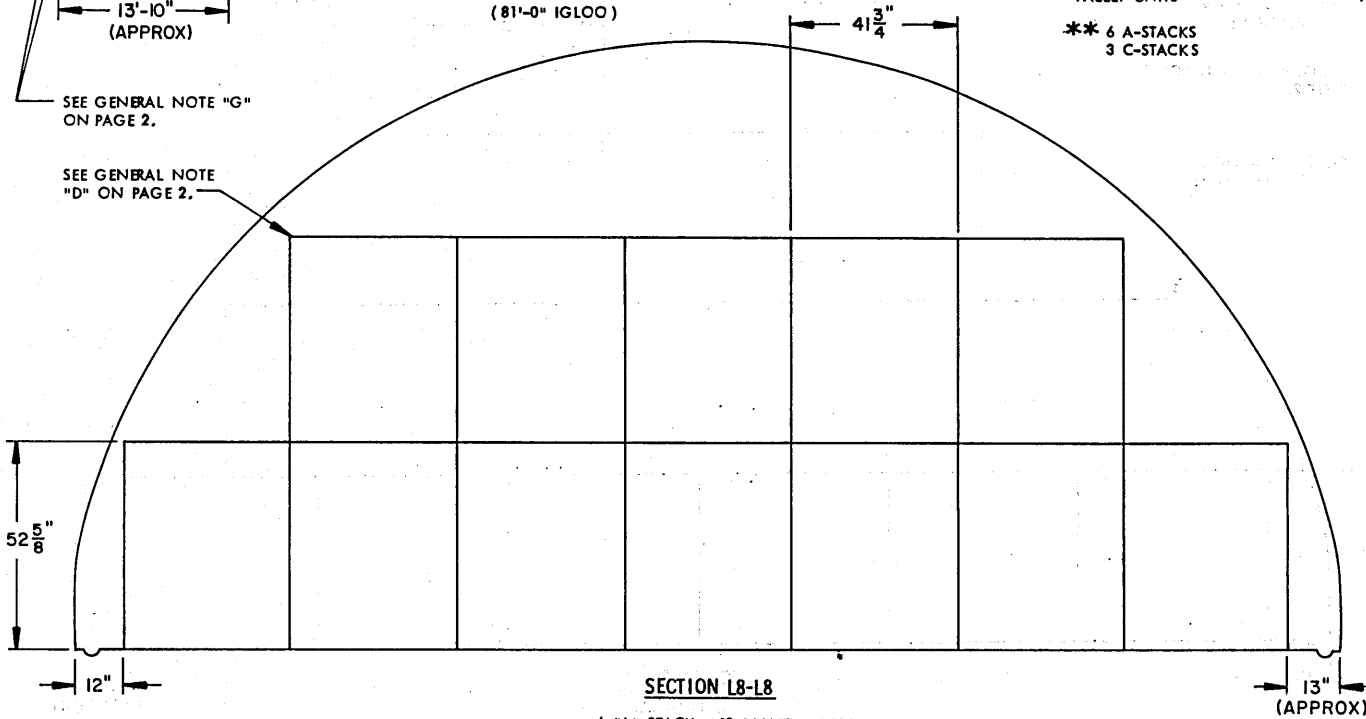

SECTION L8-L8
("A" STACK, 12 PALLET UNITS)

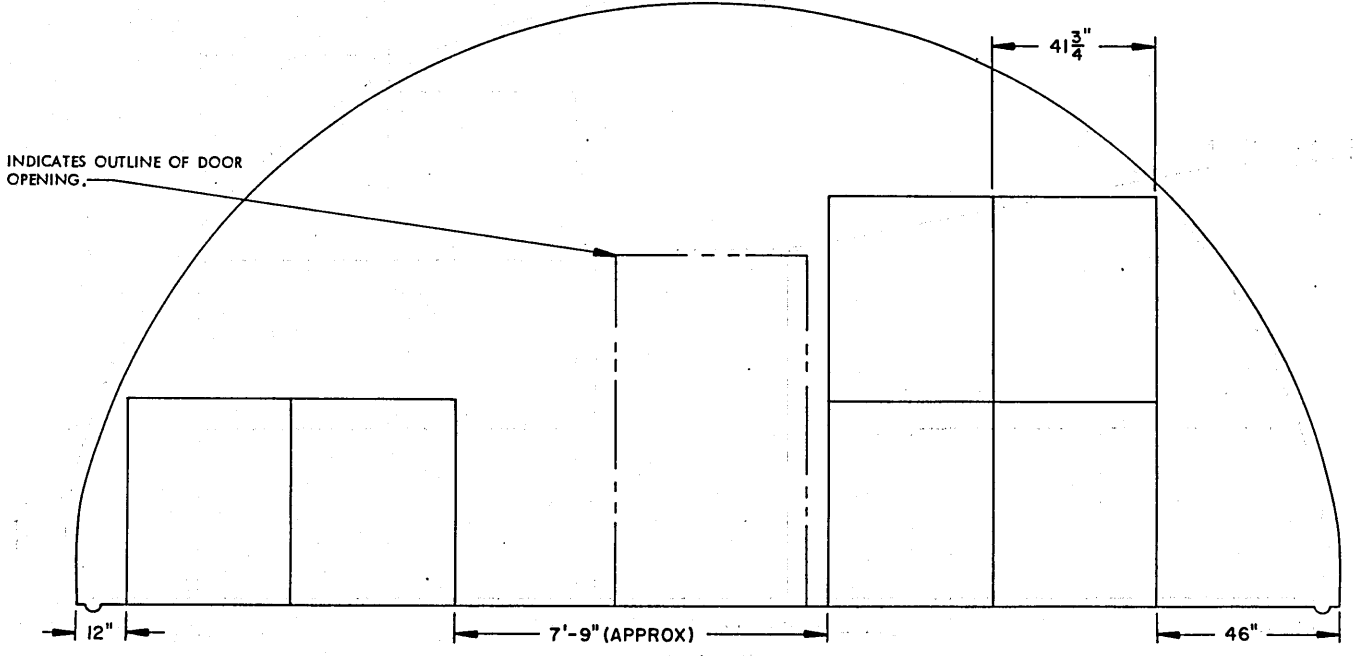

SECTION M8-M8 ("C" STACK, 6 PALLET UNITS)

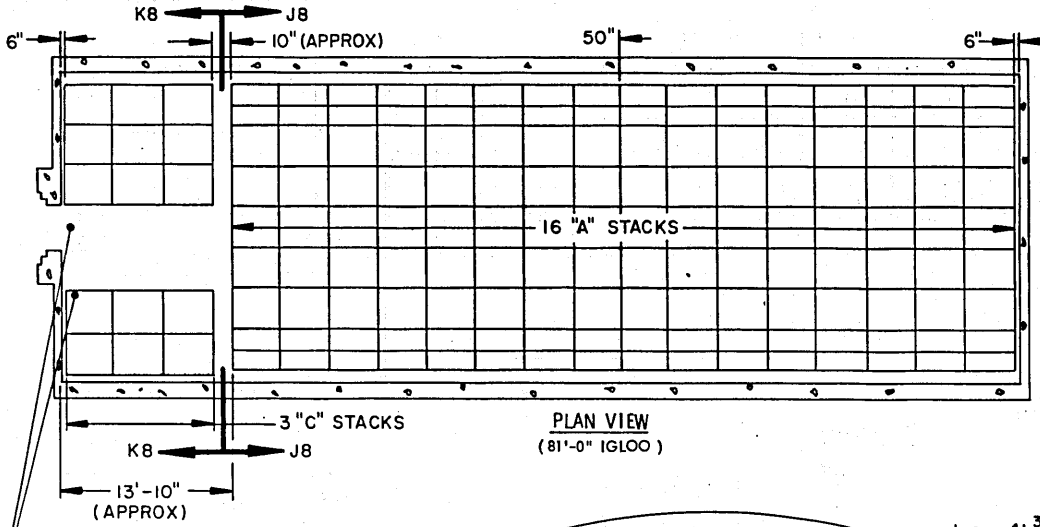

PLAN VIEW (81'-0" IGLOO)

STORAGE IN 81'-0" IGLOO

ITEM	QUANTITY
PALLET UNITS-----	331

* STORAGE IN 60'-8" IGLOO

ITEM	QUANTITY
PALLET UNITS-----	236

* 11 "A" STACKS
3 "C" STACKS

** STORAGE IN 40'-4" IGLOO

ITEM	QUANTITY
PALLET UNITS-----	141

** 6 "A" STACKS
3 "C" STACKS

SEE GENERAL NOTE "G" ON PAGE 2.

SEE GENERAL NOTE "D" ON PAGE 2.

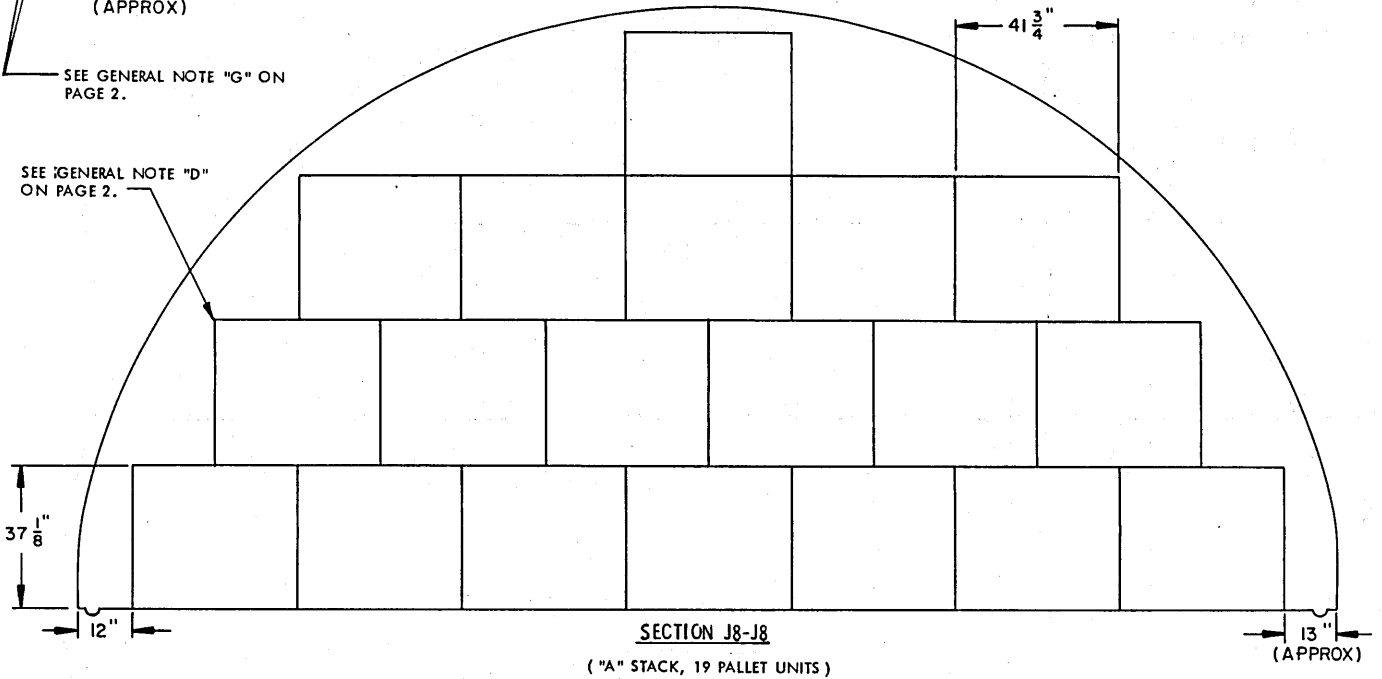

SECTION J8-J8 ("A" STACK, 19 PALLET UNITS)

INDICATES OUTLINE OF DOOR OPENING.

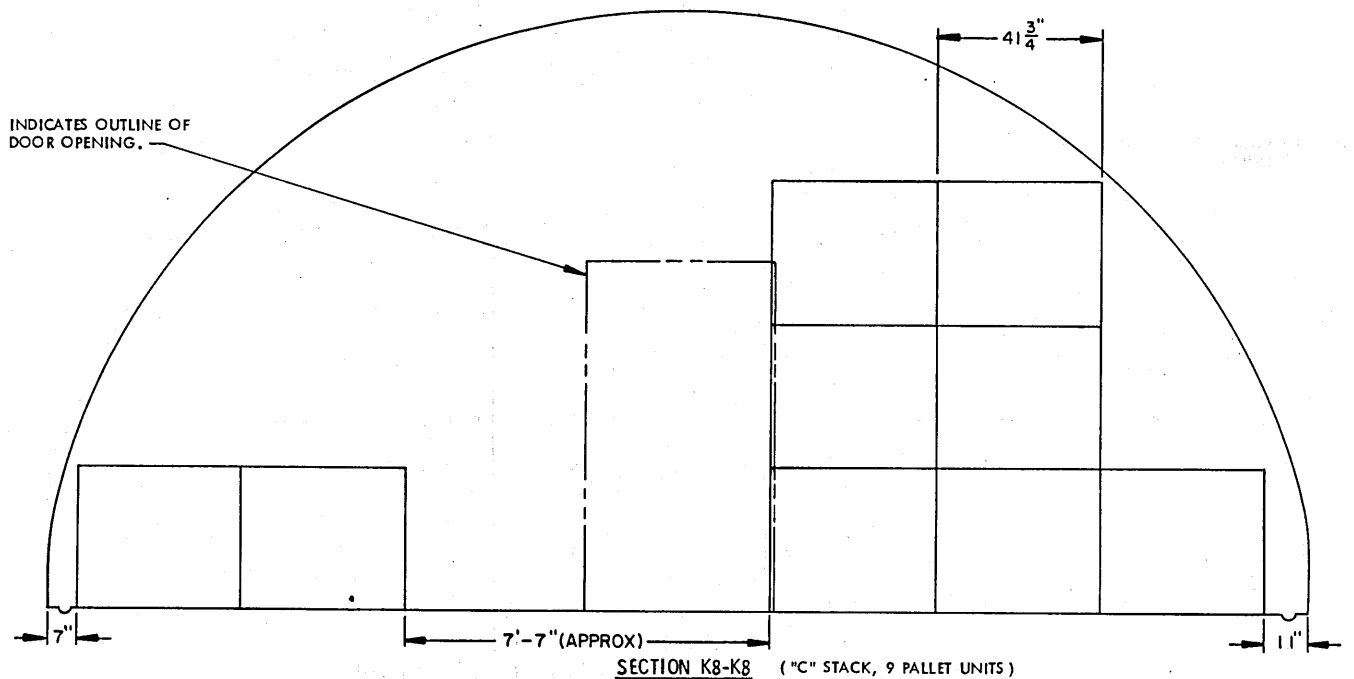

SECTION K8-K8 ("C" STACK, 9 PALLET UNITS)

STORAGE PROCEDURES FOR UNIT NO. 68 (DECREASED-HEIGHT UNIT)

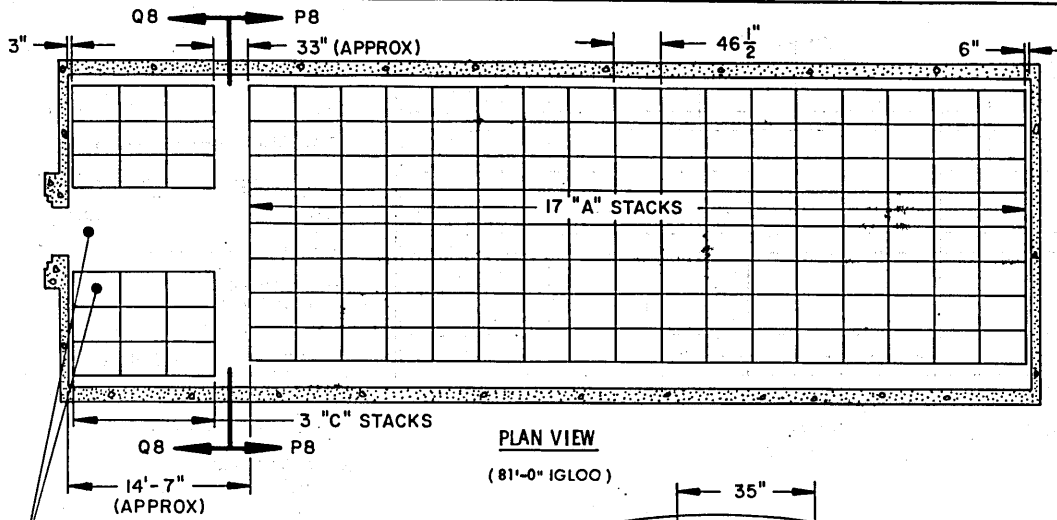

PLAN VIEW
(81'-0" IGLOO)

ITEM	QUANTITY
PALLET UNITS	279

*** STORAGE IN 60'-8" IGLOO**

ITEM	QUANTITY
PALLET UNITS	204
* 12 A-STACKS	
3 C-STACKS	

**** STORAGE IN 40'-4" IGLOO**

ITEM	QUANTITY
PALLET UNITS	129
** 7 A-STACKS	
3 C-STACKS	

SEE GENERAL NOTE "G" ON PAGE 2.

SEE GENERAL NOTE "D" ON PAGE 2.

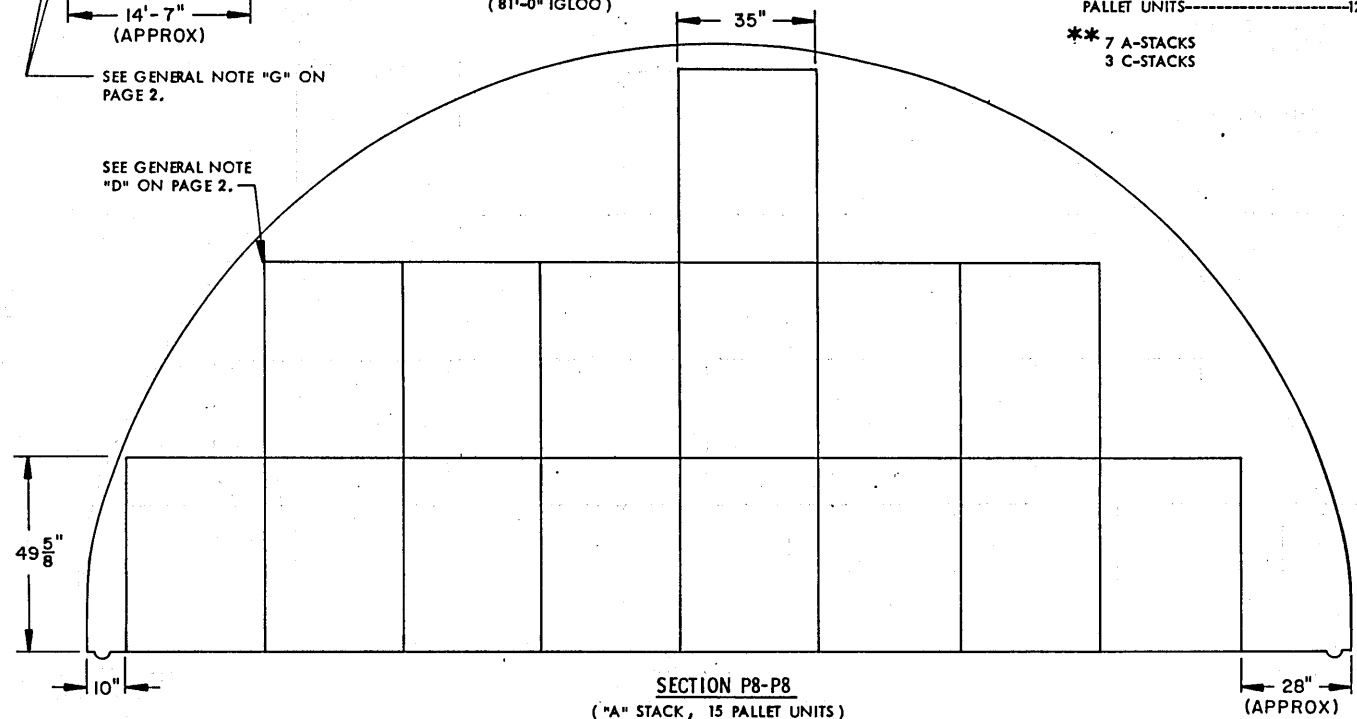

SECTION P8-P8
(*A" STACK, 15 PALLET UNITS)

INDICATES OUTLINE OF DOOR OPENING.

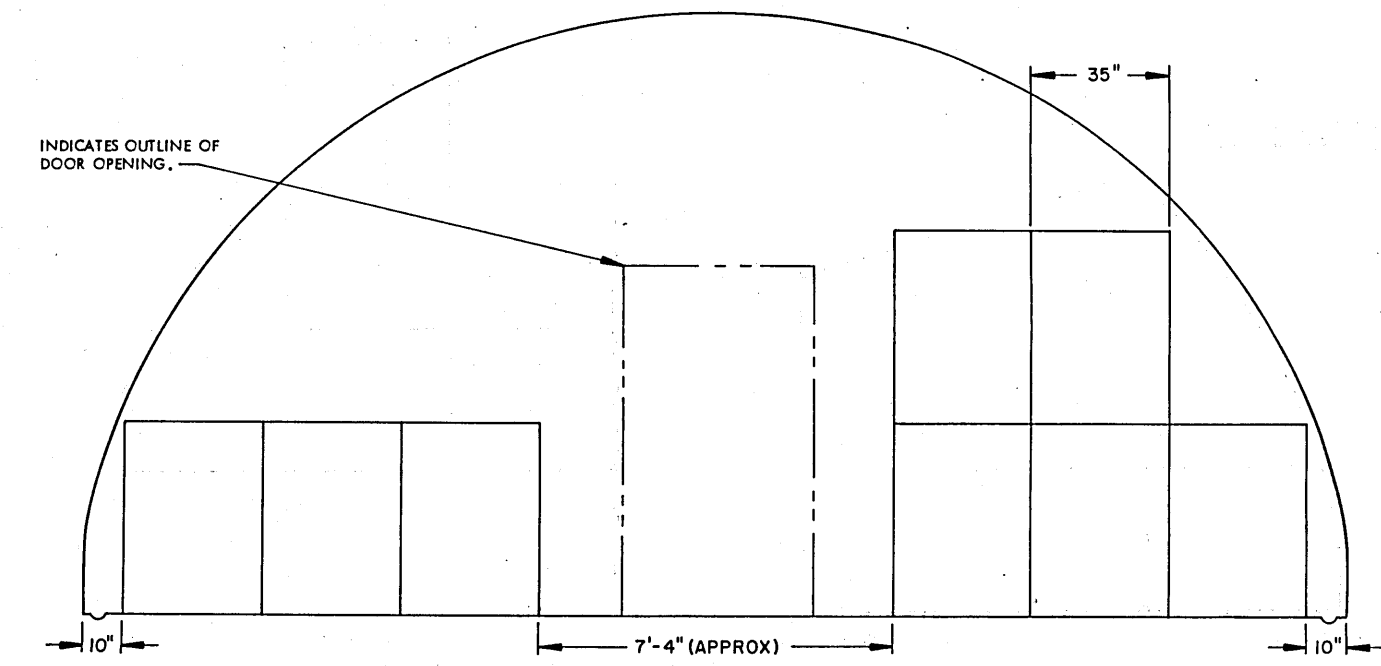

SECTION Q8-Q8 ("C" STACK, 8 PALLET UNITS)

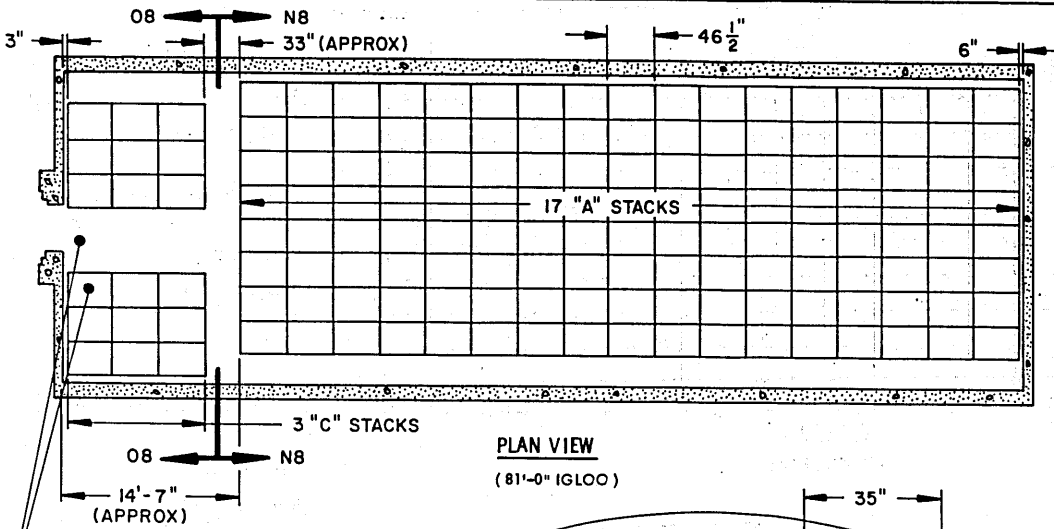

STORAGE IN 81'-0" IGLOO

ITEM	QUANTITY
PALLET UNITS	353

*** STORAGE IN 60'-8" IGLOO**

ITEM	QUANTITY
PALLET UNITS	258

- * 12 A-STACKS
- 3 C-STACKS

**** STORAGE IN 40'-4" IGLOO**

ITEM	QUANTITY
PALLET UNITS	163

- ** 7 A-STACKS
- 3 C-STACKS

SEE GENERAL NOTE "G" ON PAGE 2.

SEE GENERAL NOTE "D" ON PAGE 2.

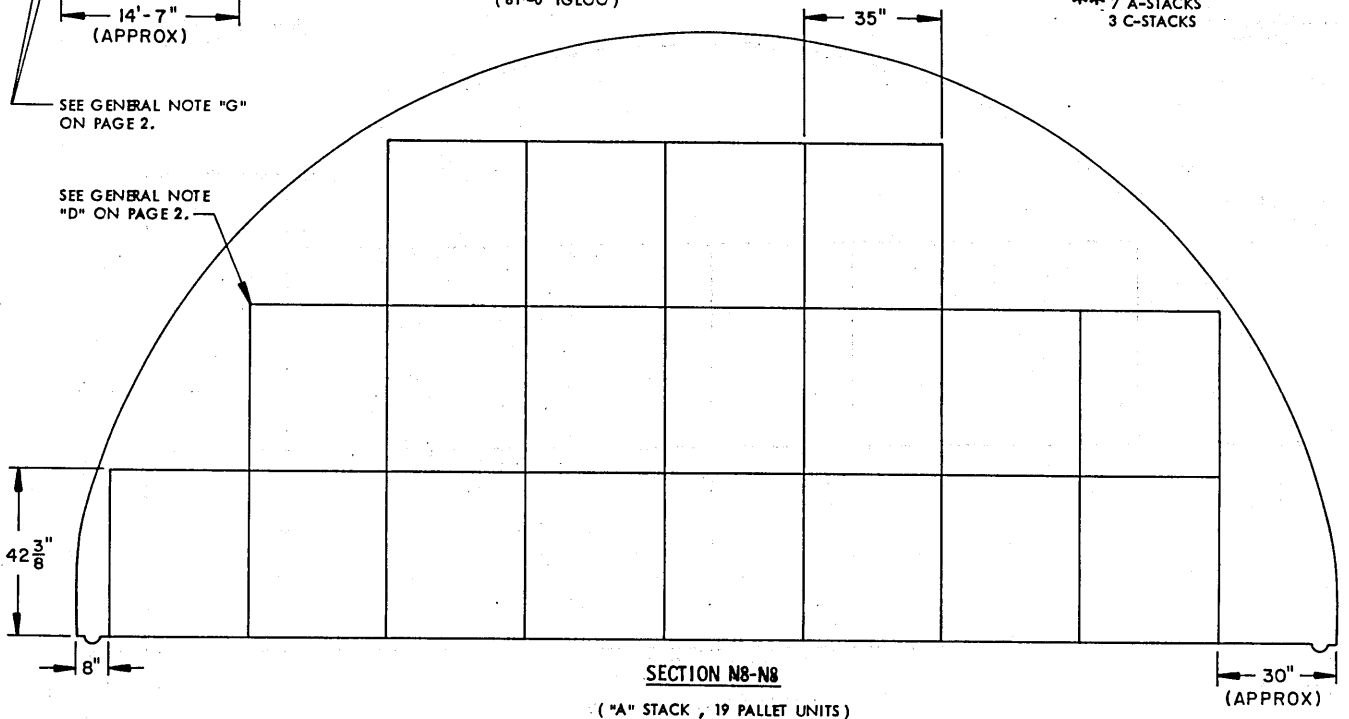

INDICATES OUTLINE OF DOOR OPENING.

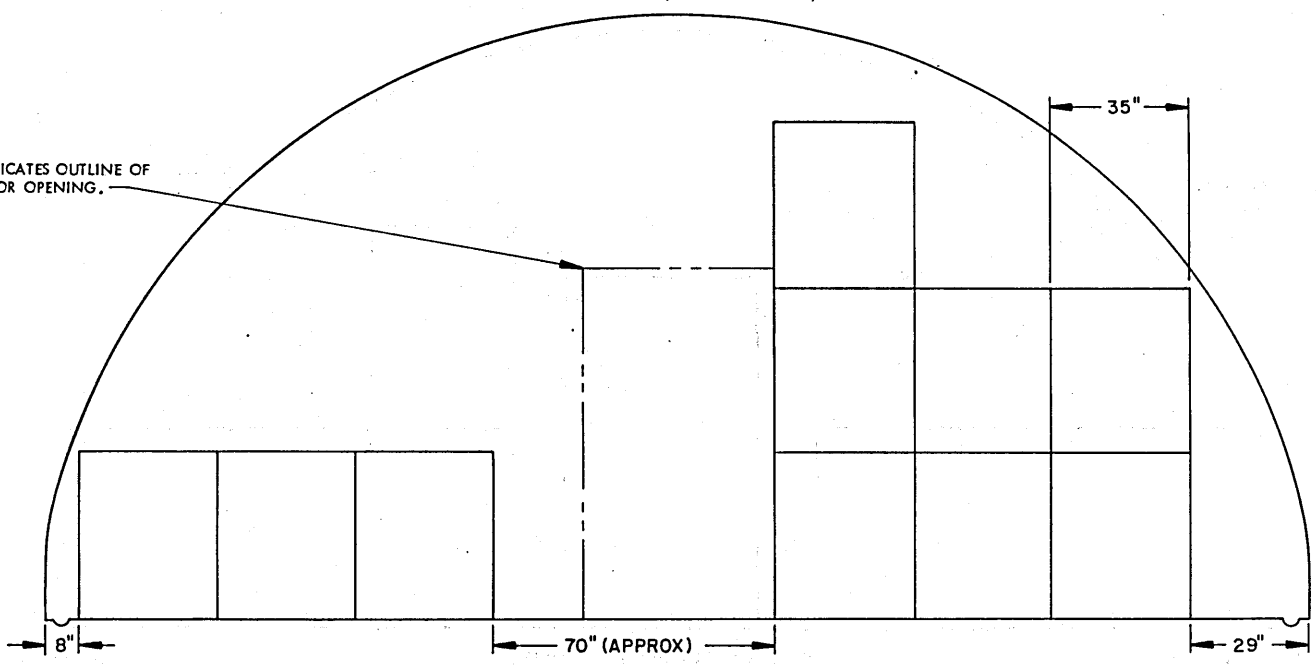

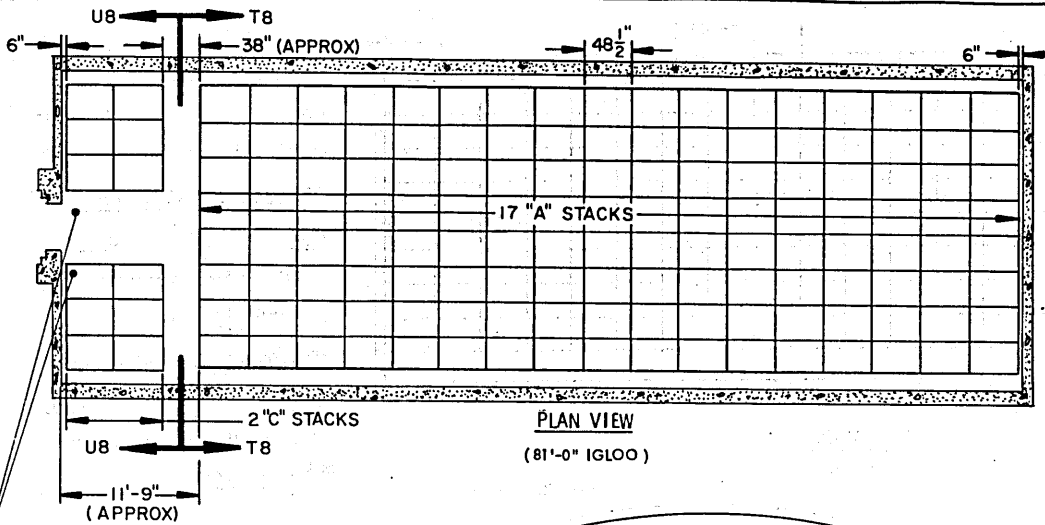

PLAN VIEW
(81'-0" IGLOO)

STORAGE IN 81'-0" IGLOO

ITEM	QUANTITY
PALLET UNITS-----	254

* STORAGE IN 60'-8" IGLOO

ITEM	QUANTITY
PALLET UNITS-----	184

- * 12 "A" STACKS
- 2 "C" STACKS

** STORAGE IN 40'-4" IGLOO

ITEM	QUANTITY
PALLET UNITS-----	114

- ** 7 "A" STACKS
- 2 "C" STACKS

SEE GENERAL NOTE "G"
ON PAGE 2.

SEE GENERAL NOTE "D"
ON PAGE 2.

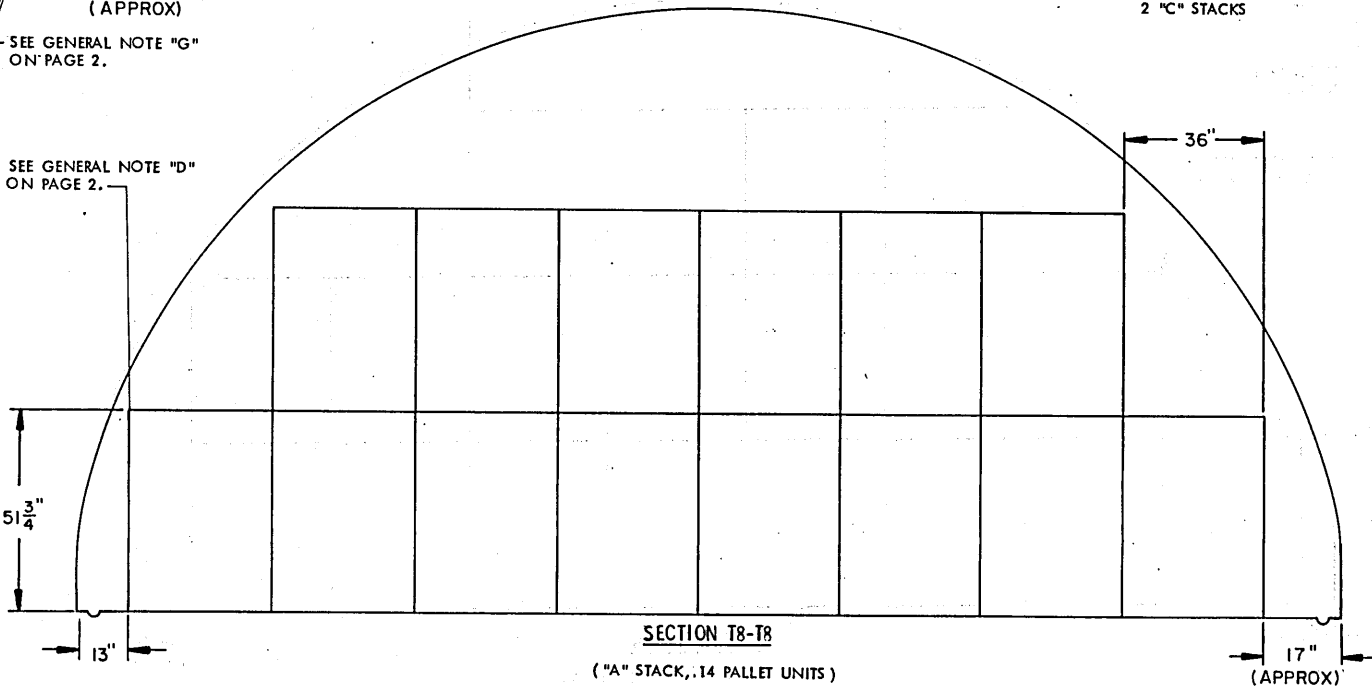

SECTION T8-T8
("A" STACK, 14 PALLET UNITS)

INDICATES OUTLINE OF
DOOR OPENING.

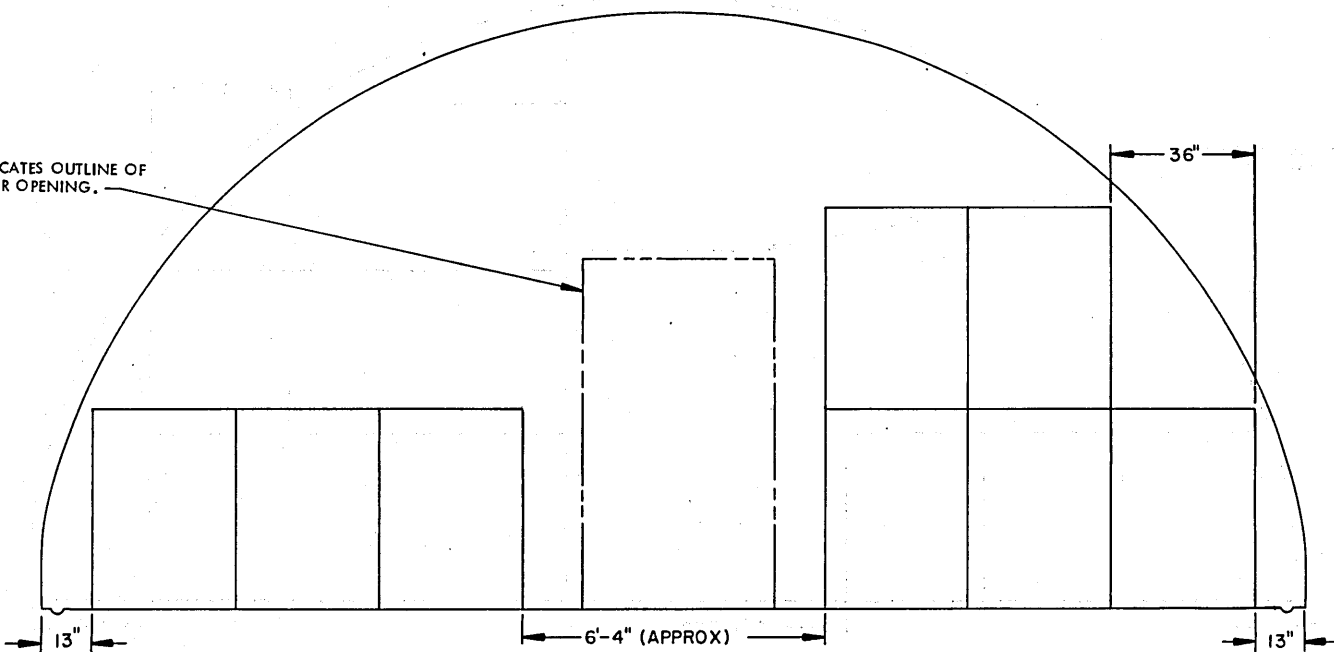

SECTION U8-U8 ("C" STACK, 8 PALLET UNITS)

STORAGE PROCEDURES FOR UNIT NO. 70

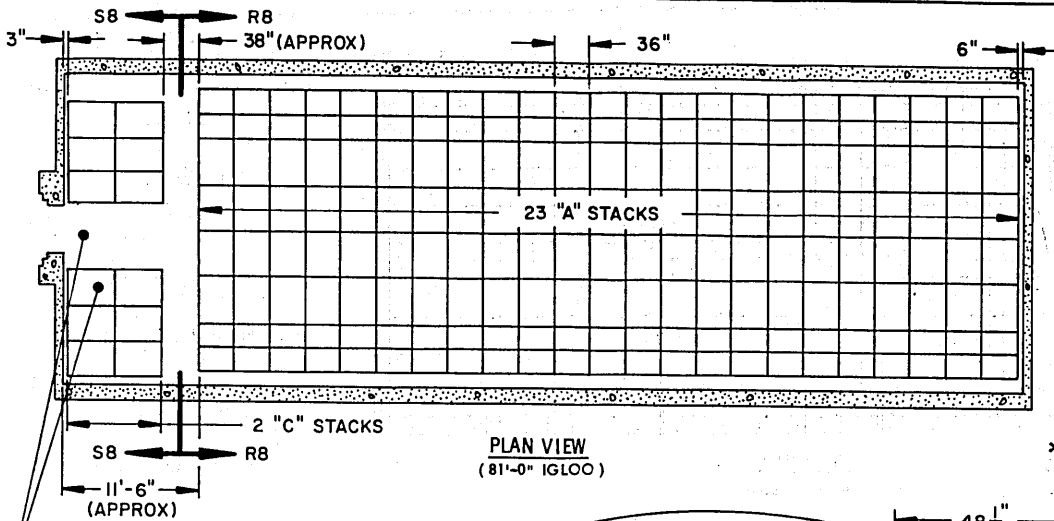

STORAGE IN 81'-0" IGLOO	
ITEM	QUANTITY
PALLET UNITS	367
* STORAGE IN 60'-8" IGLOO	
ITEM	QUANTITY
PALLET UNITS	262
* 16 A-STACKS	
2 C-STACKS	
** STORAGE IN 40'-4" IGLOO	
ITEM	QUANTITY
PALLET UNITS	168
** 9 A-STACKS	
3 C-STACKS	

SEE GENERAL NOTE "G" ON PAGE 2.

SEE GENERAL NOTE "D" ON PAGE 2.

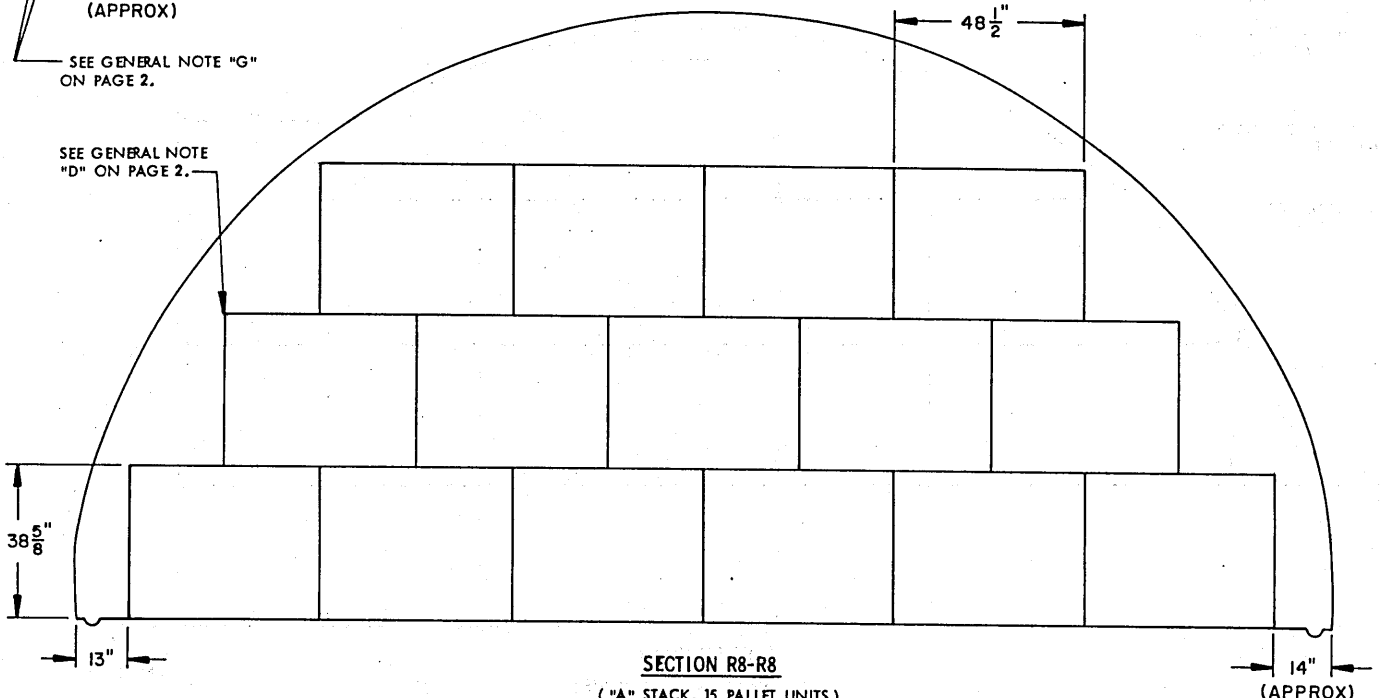

INDICATES OUTLINE OF DOOR OPENING.

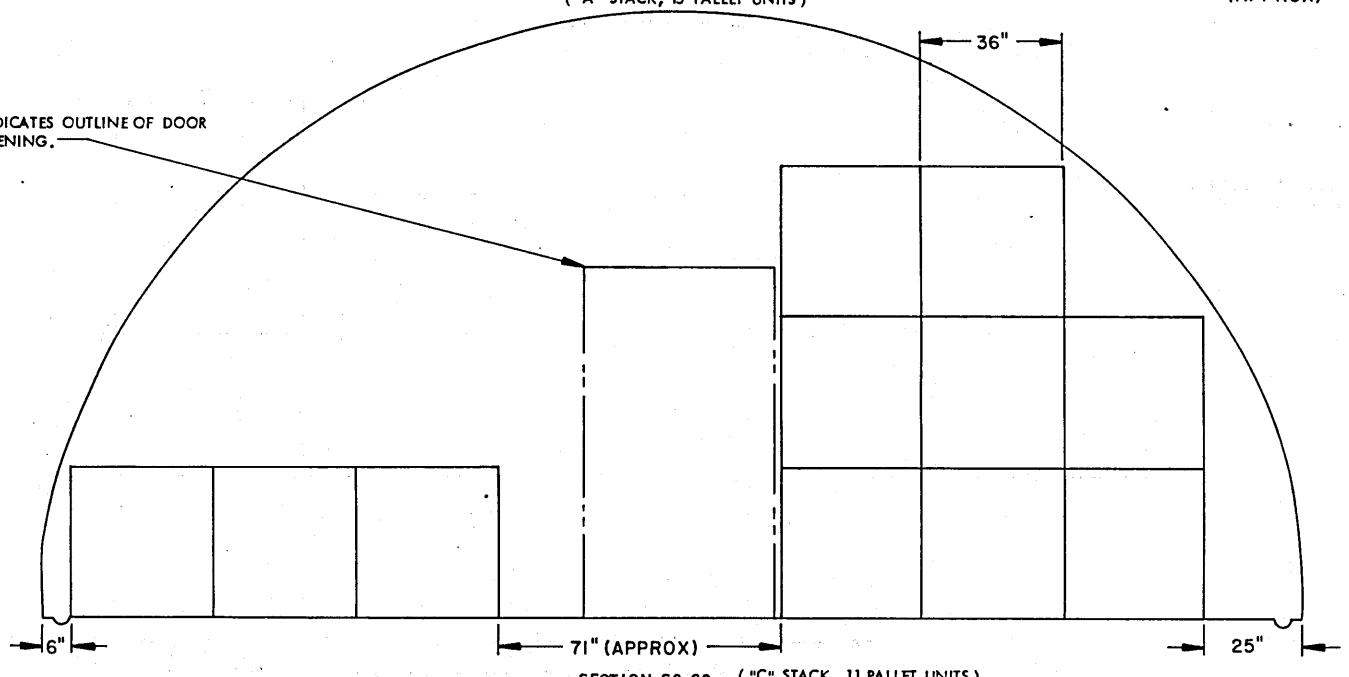

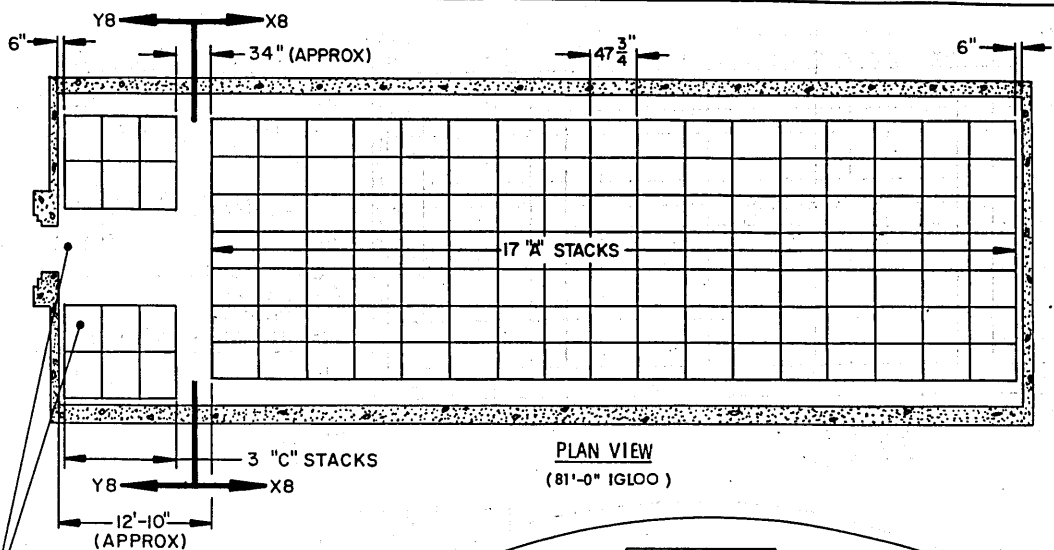

PLAN VIEW
(81'-0" IGLOO)

STORAGE IN 81'-0" IGLOO	
ITEM	QUANTITY
PALLET UNITS	361
* STORAGE IN 60'-8" IGLOO	
ITEM	QUANTITY
PALLET UNITS	261
* 12 "A" STACKS	
3 "C" STACKS	
* * STORAGE IN 40'-4" IGLOO	
ITEM	QUANTITY
PALLET UNITS	161
** 7 "A" STACKS	
3 "C" STACKS	

SEE GENERAL NOTE "G" ON PAGE 2.

SEE GENERAL NOTE "D" ON PAGE 2.

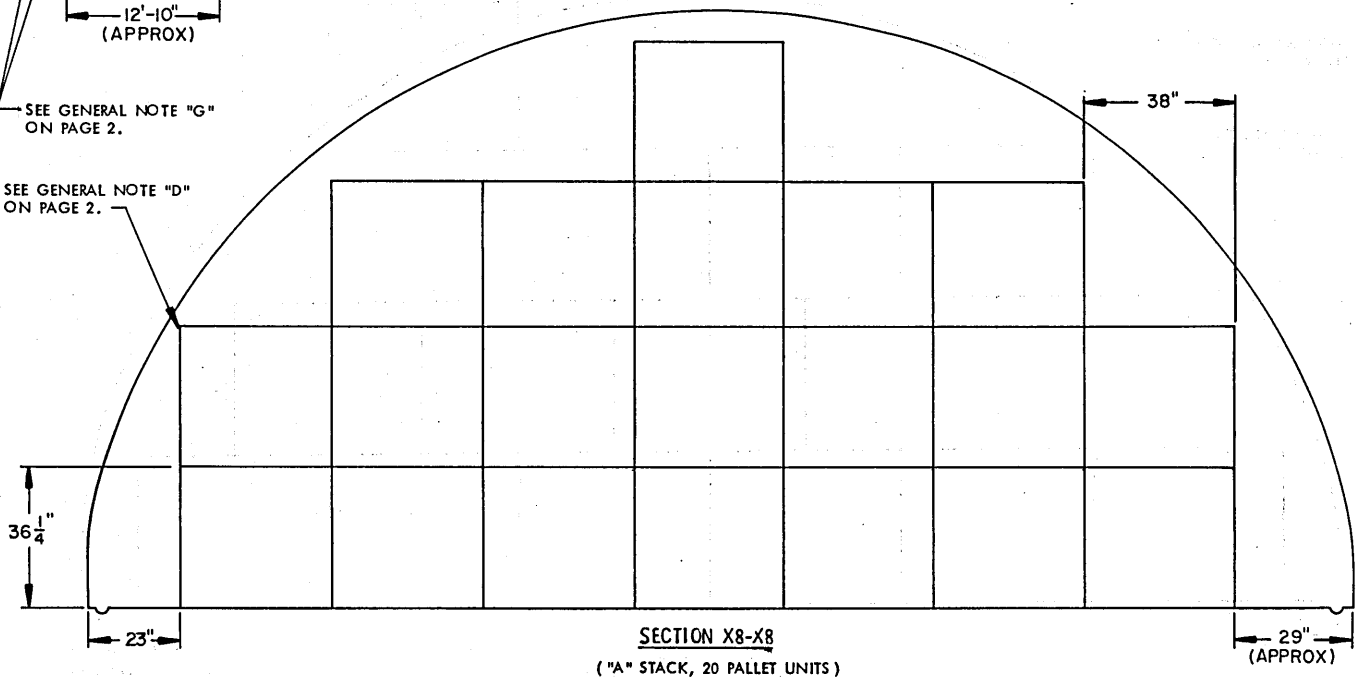

SECTION X8-X8
("A" STACK, 20 PALLET UNITS)

INDICATES OUTLINE OF DOOR OPENING.

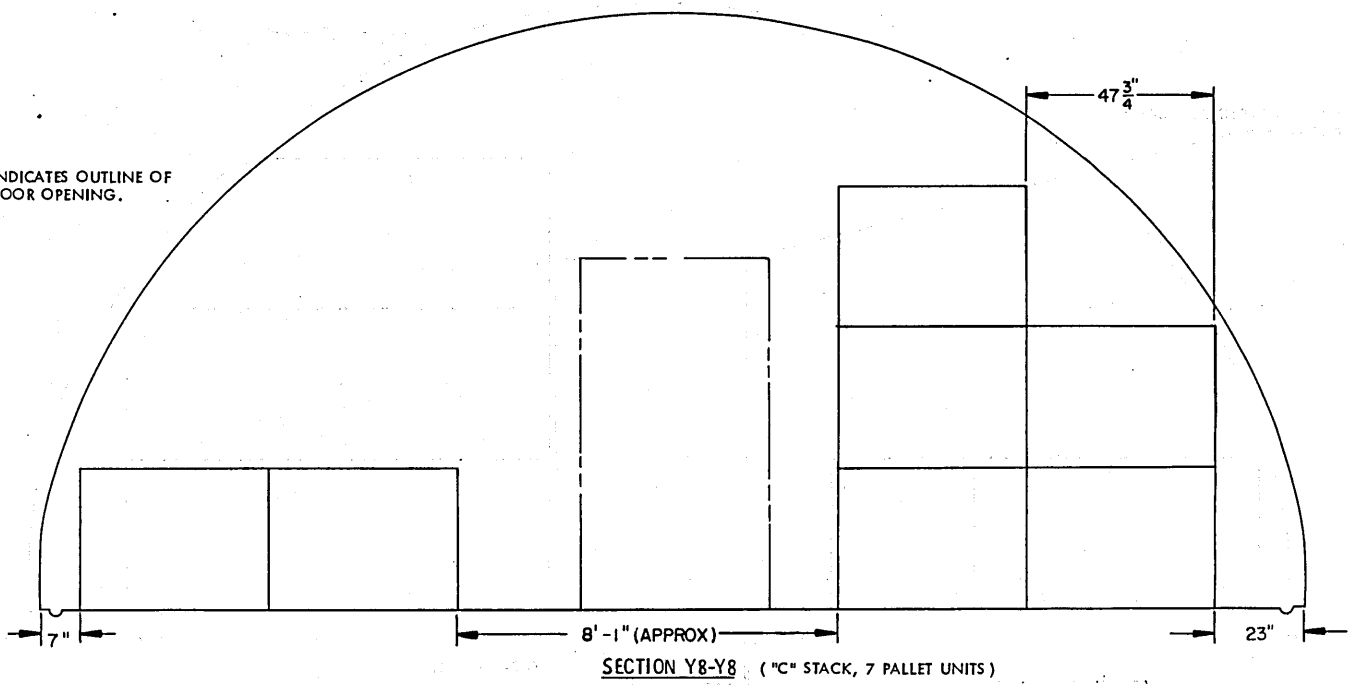

SECTION Y8-Y8 ("C" STACK, 7 PALLET UNITS)

THIS PAGE INTENTIONALLY LEFT BLANK

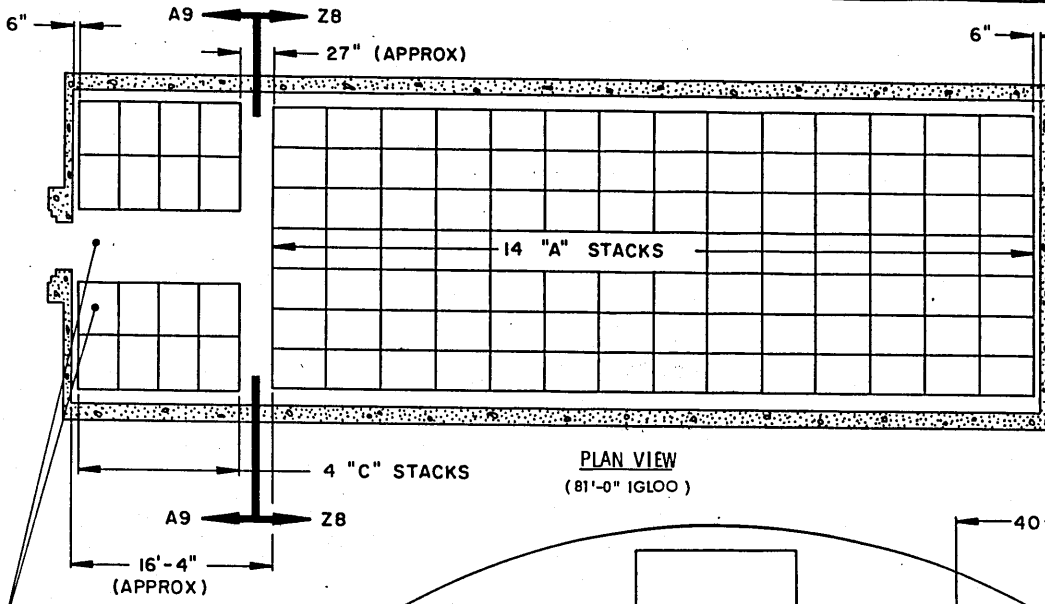

PLAN VIEW
(81'-0" IGLOO)

STORAGE IN 81'-0" IGLOO

ITEM	QUANTITY
PALLET UNITS-----	202

* STORAGE IN 60'-8" IGLOO

ITEM	QUANTITY
PALLET UNITS-----	145

* 10 "A" STACKS
3 "C" STACKS

** STORAGE IN 40'-4" IGLOO

ITEM	QUANTITY
PALLET UNITS-----	93

** 6 "A" STACKS
3 "C" STACKS

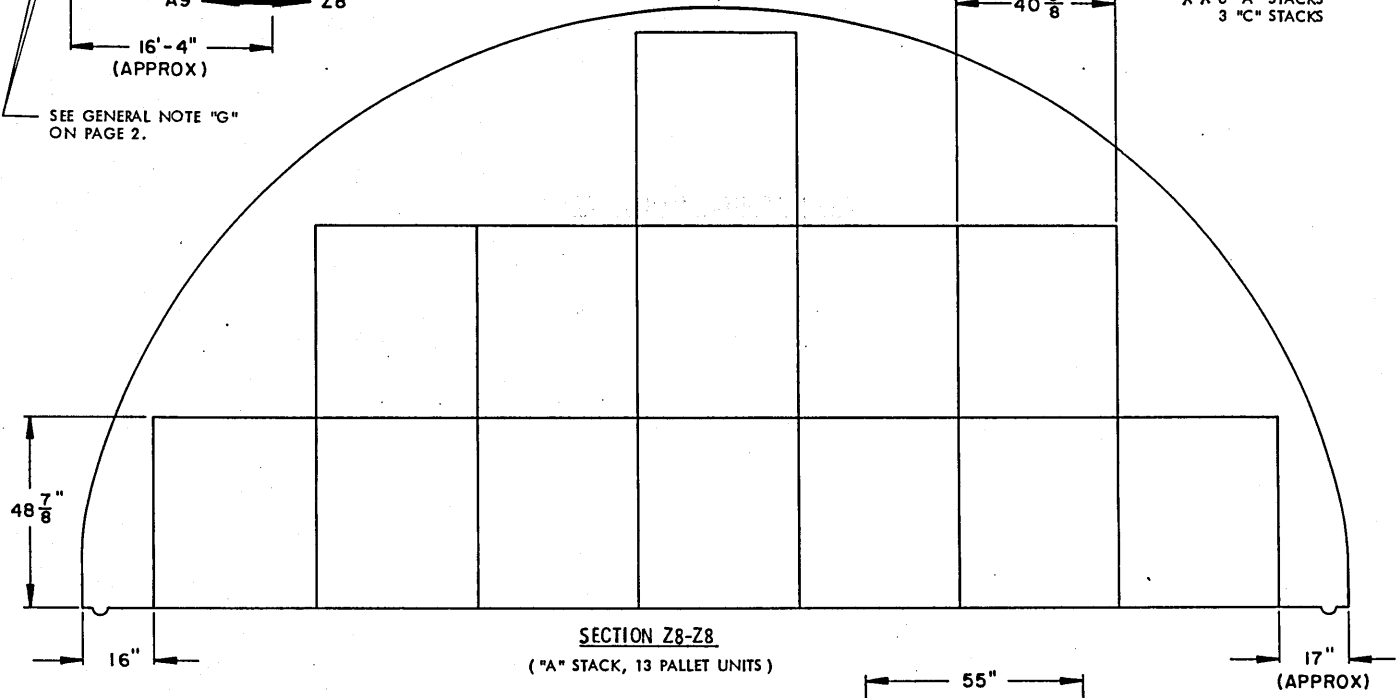

SECTION Z8-Z8
("A" STACK, 13 PALLET UNITS)

INDICATES OUTLINE OF
DOOR OPENING.

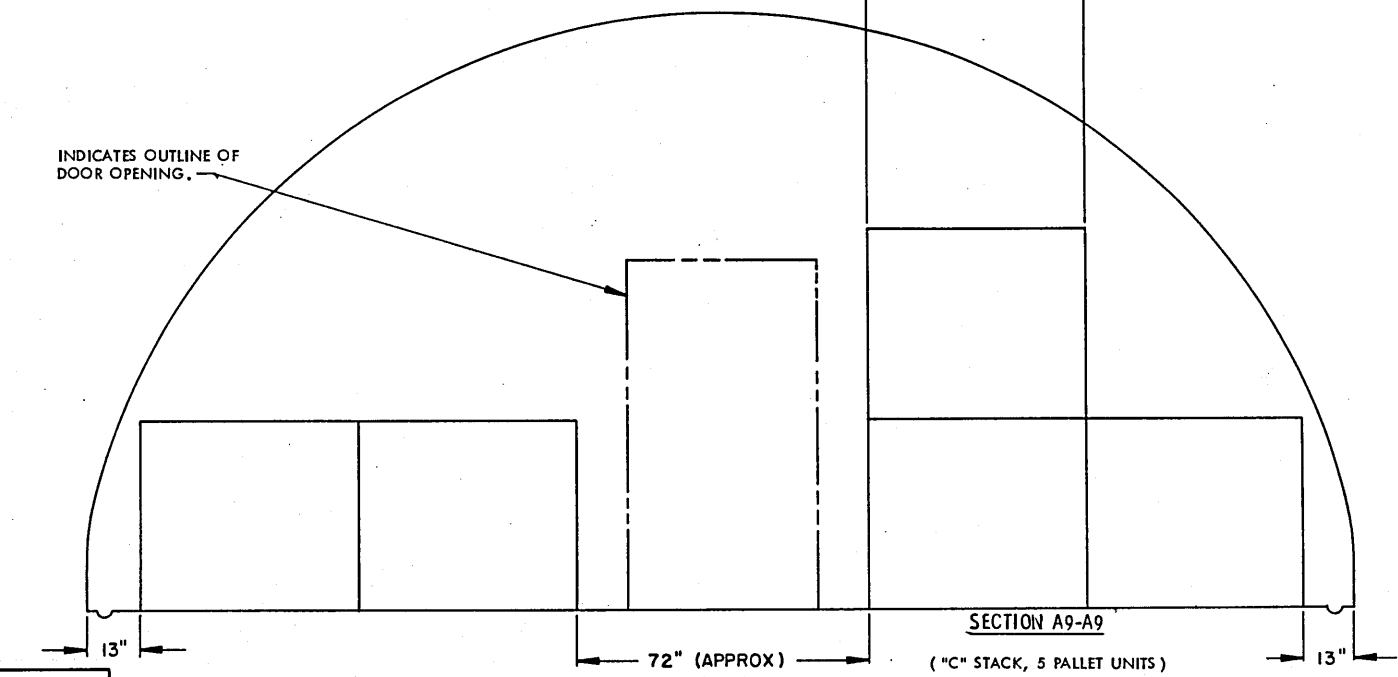

SECTION A9-A9
("C" STACK, 5 PALLET UNITS)

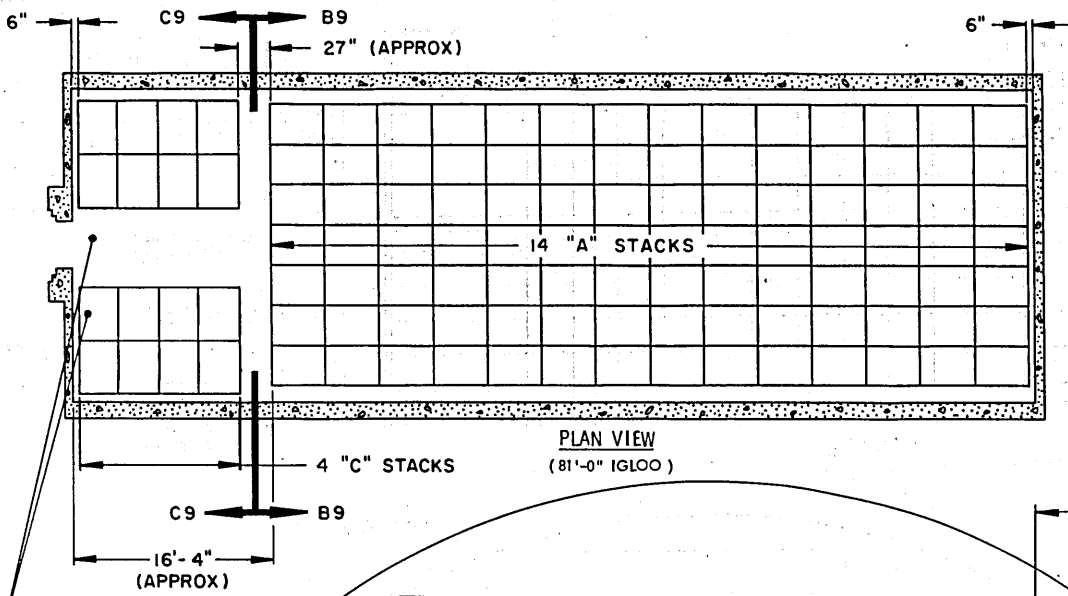

STORAGE IN 81'-0" IGLOO	
ITEM	QUANTITY
PALLET UNITS-----	262
* STORAGE IN 60'-8" IGLOO	
ITEM	QUANTITY
PALLET UNIT-----	188
* 10 "A" STACKS	
3 "C" STACKS	
** STORAGE IN 40'-4" IGLOO	
ITEM	QUANTITY
PALLET UNIT-----	120
** 6 "A" STACKS	
3 "C" STACKS	

SEE GENERAL NOTE "G" ON PAGE 2.

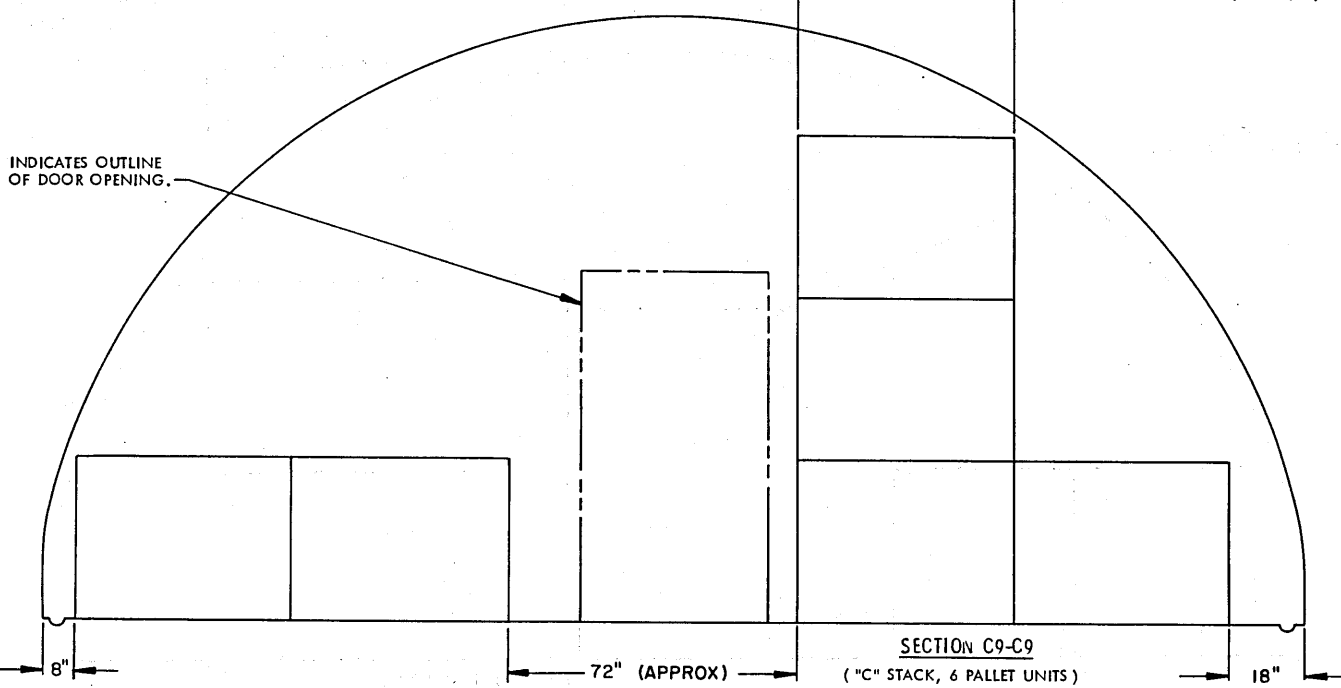
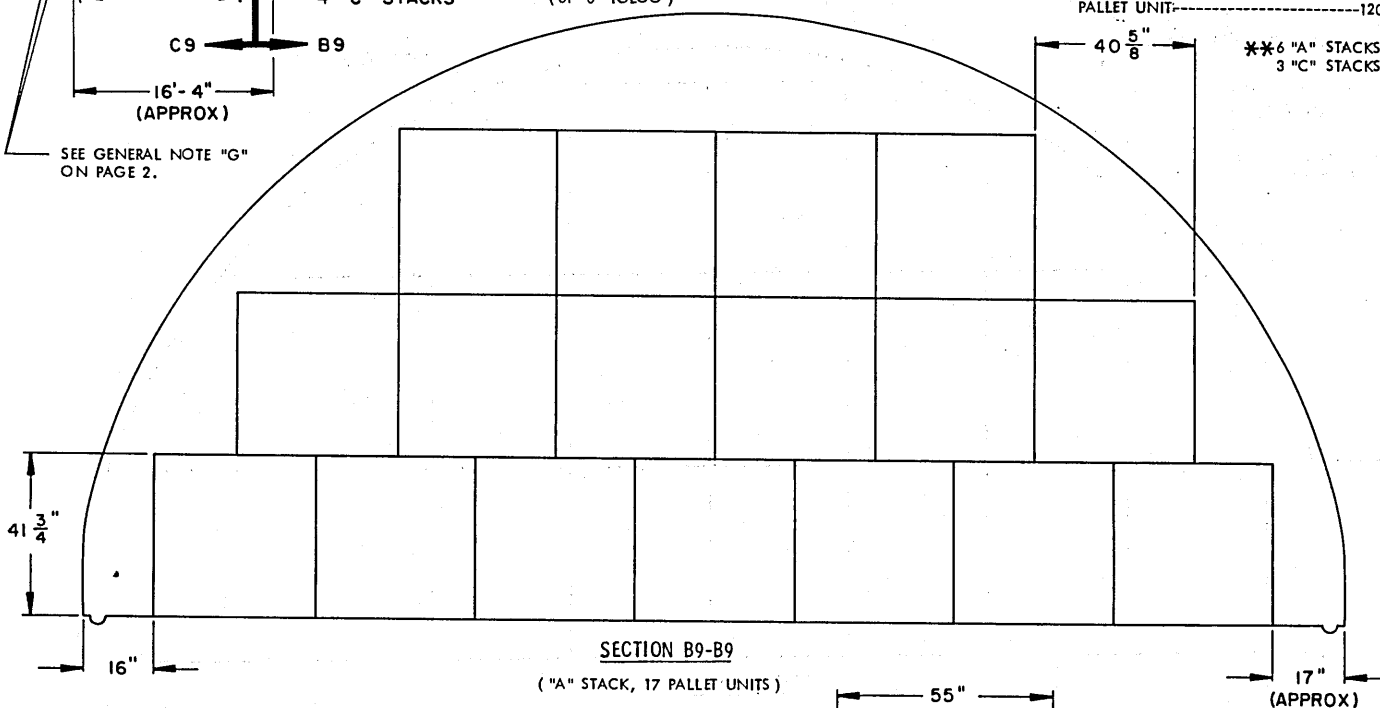

STORAGE PROCEDURES FOR UNIT NO. 72 (DECREASED-HEIGHT UNIT)

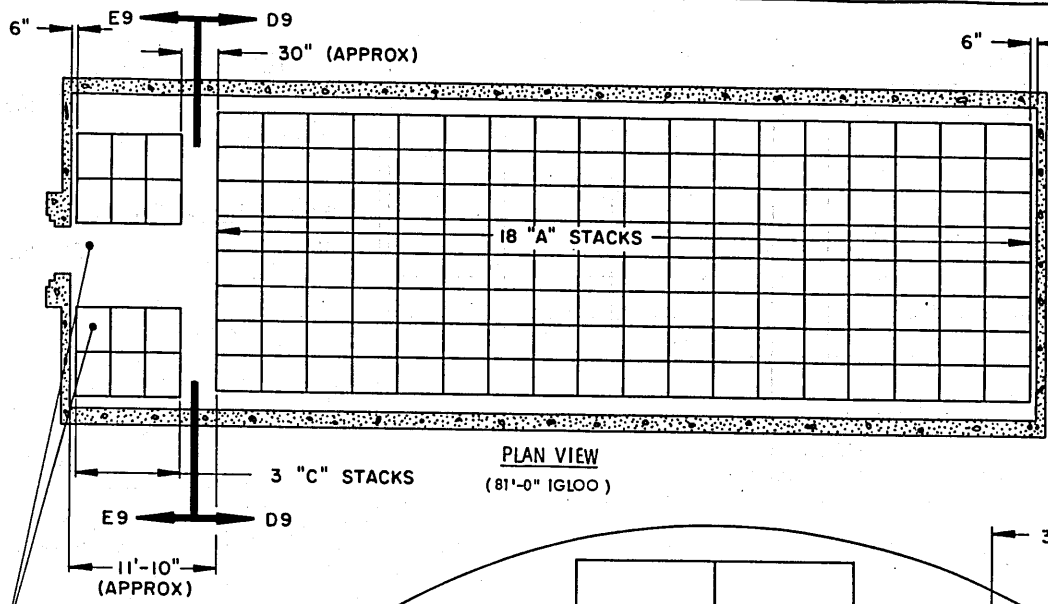

STORAGE IN 81'-0" IGLOO	
ITEM	QUANTITY
PALLET UNITS	306
* STORAGE IN 60'-8" IGLOO	
ITEM	QUANTITY
PALLET UNITS	216
* 12 "A" STACKS	
4 "C" STACKS	
** STORAGE IN 40'-4" IGLOO	
ITEM	QUANTITY
PALLET UNITS	136
** 7 "A" STACKS	
4 "C" STACKS	

PLAN VIEW
(81'-0" IGLOO)

SEE GENERAL NOTE "G" ON PAGE 2.

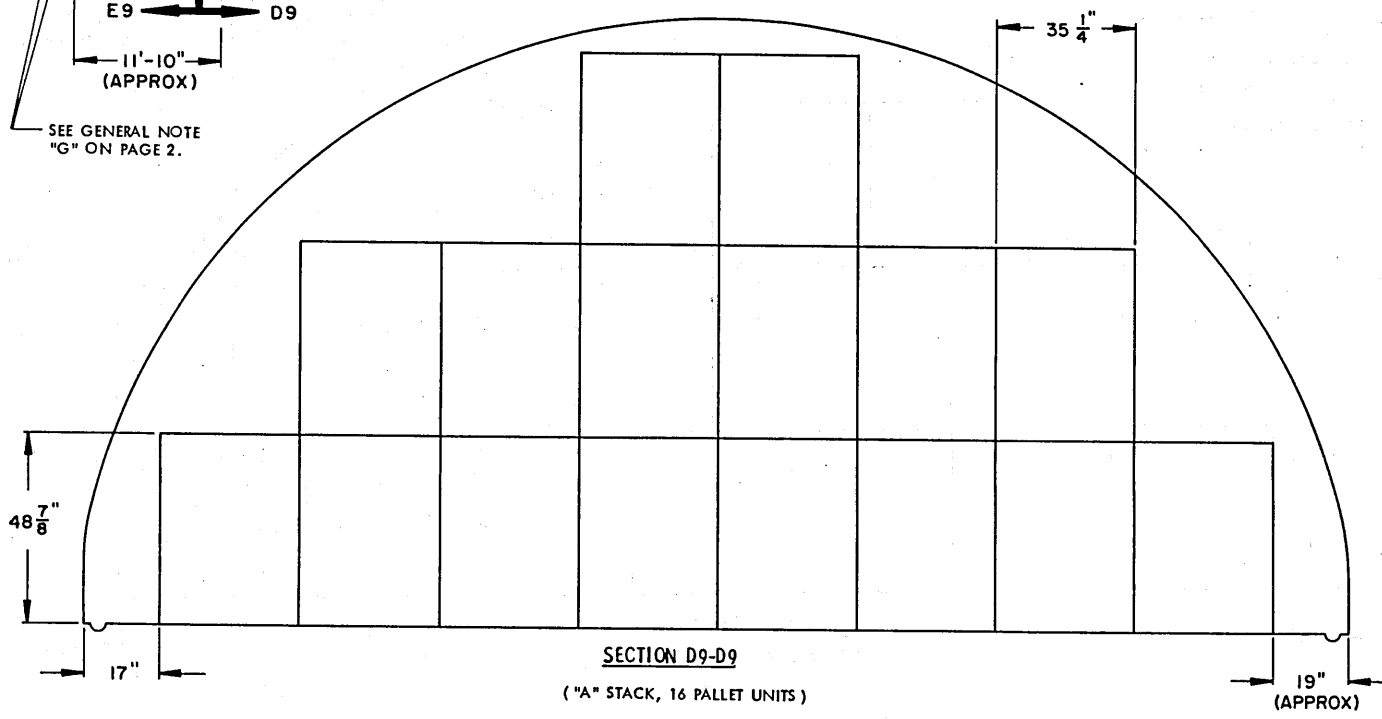

SECTION D9-D9
("A" STACK, 16 PALLET UNITS)

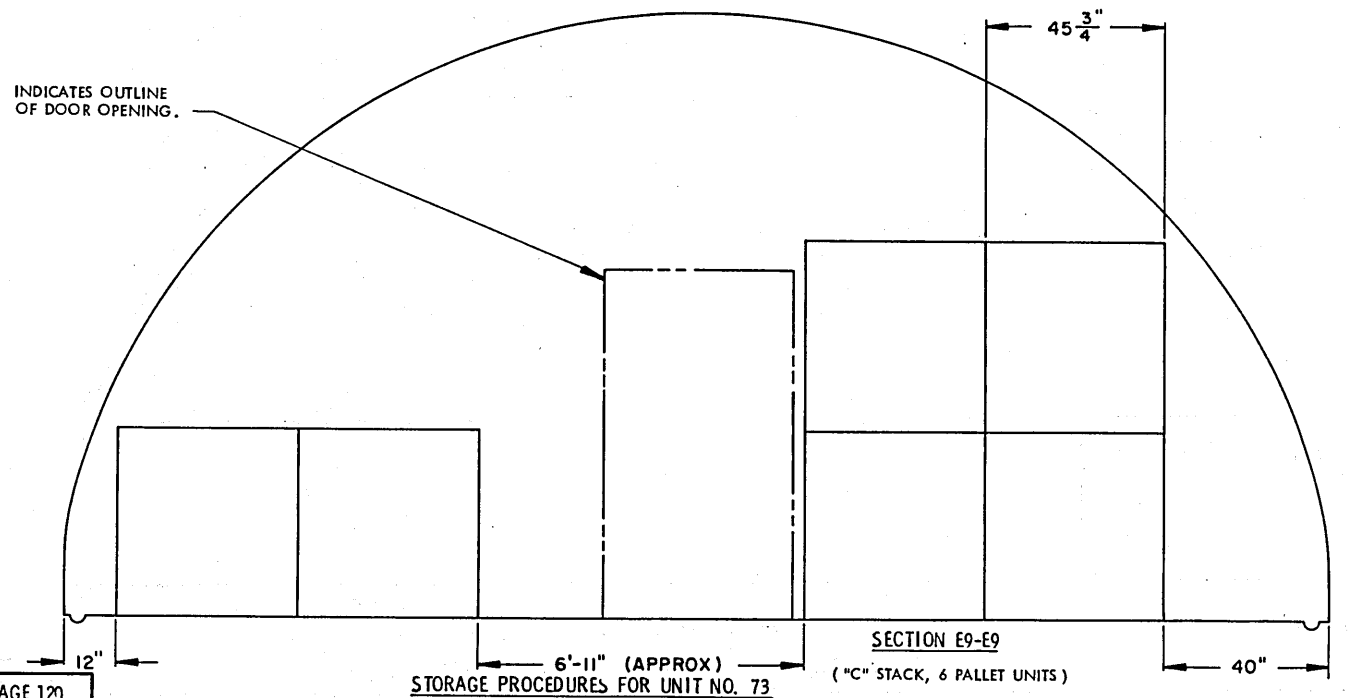

SECTION E9-E9
("C" STACK, 6 PALLET UNITS)
STORAGE PROCEDURES FOR UNIT NO. 73

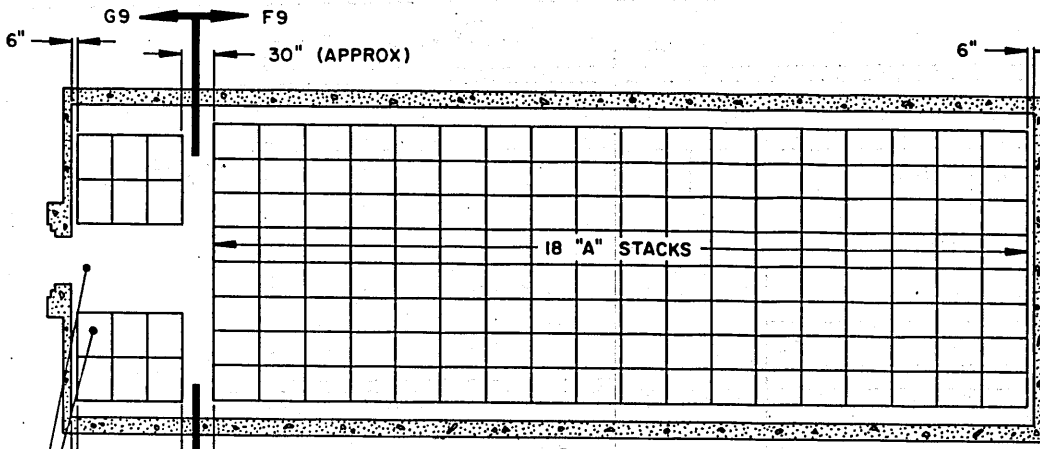

PLAN VIEW (81'-0" IGLOO)

STORAGE IN 81'-0" IGLOO

ITEM	QUANTITY
PALLET UNIT	345

* STORAGE IN 60'-8" IGLOO

ITEM	QUANTITY
PALLET UNIT	244
* 12 "A" STACKS	
4 "C" STACKS	

** STORAGE IN 40'-4" IGLOO

ITEM	QUANTITY
PALLET UNIT	154
** 7 "A" STACKS	
4 "C" STACKS	

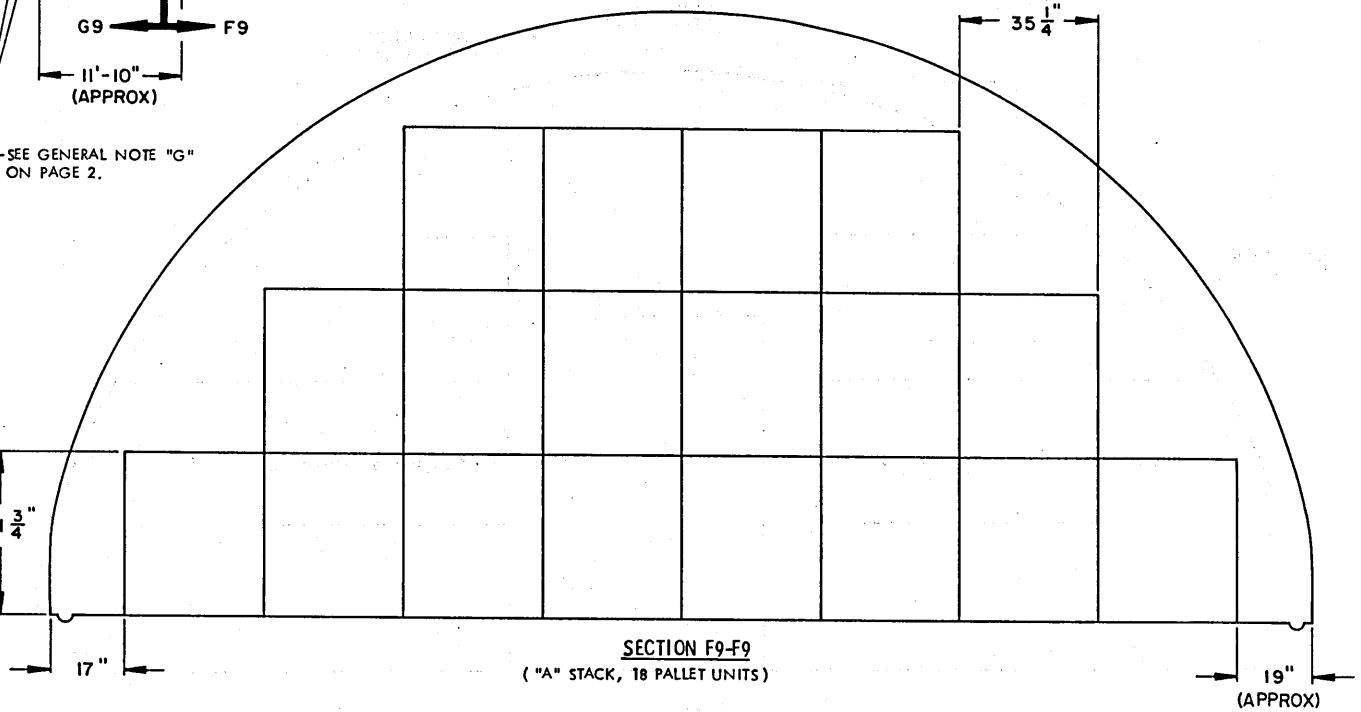

INDICATES OUTLINE OF DOOR OPENING.

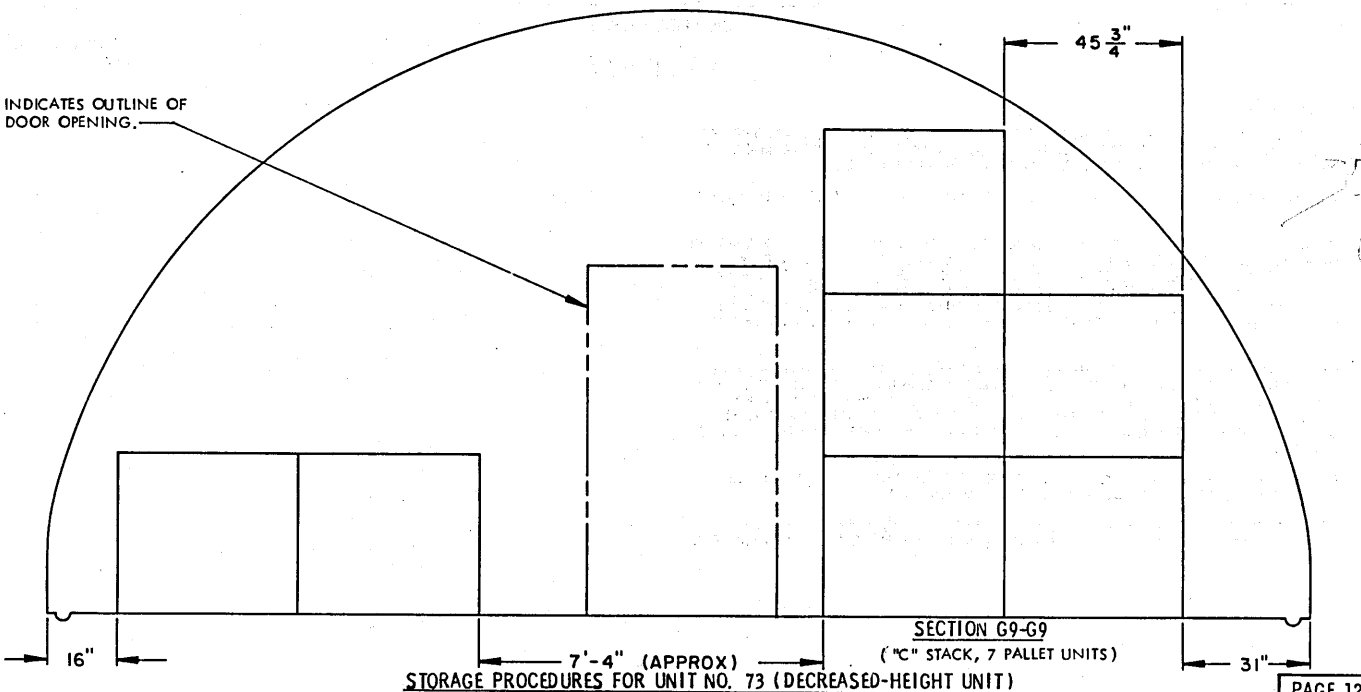

STORAGE PROCEDURES FOR UNIT NO. 73 (DECREASED-HEIGHT UNIT)

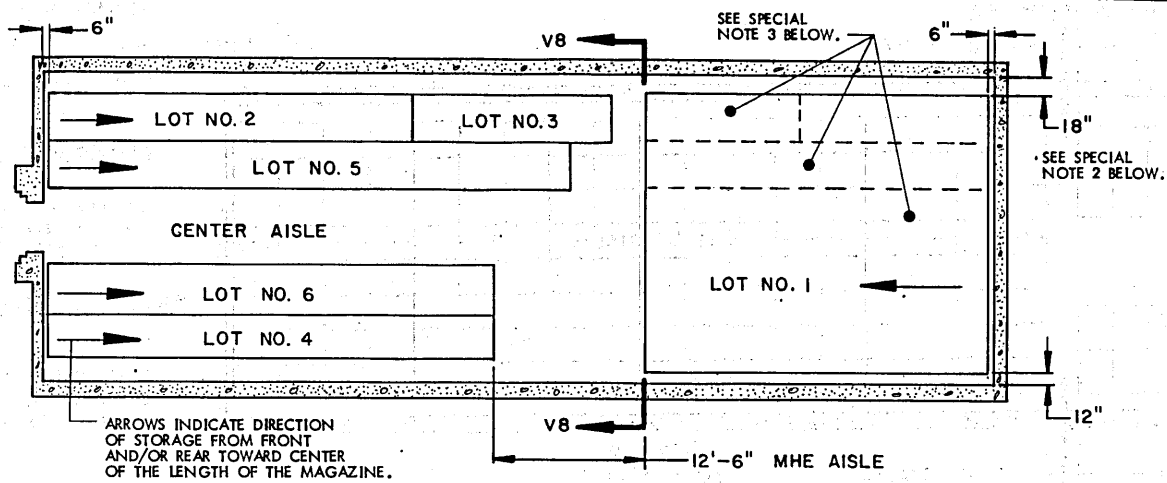

PLAN VIEW

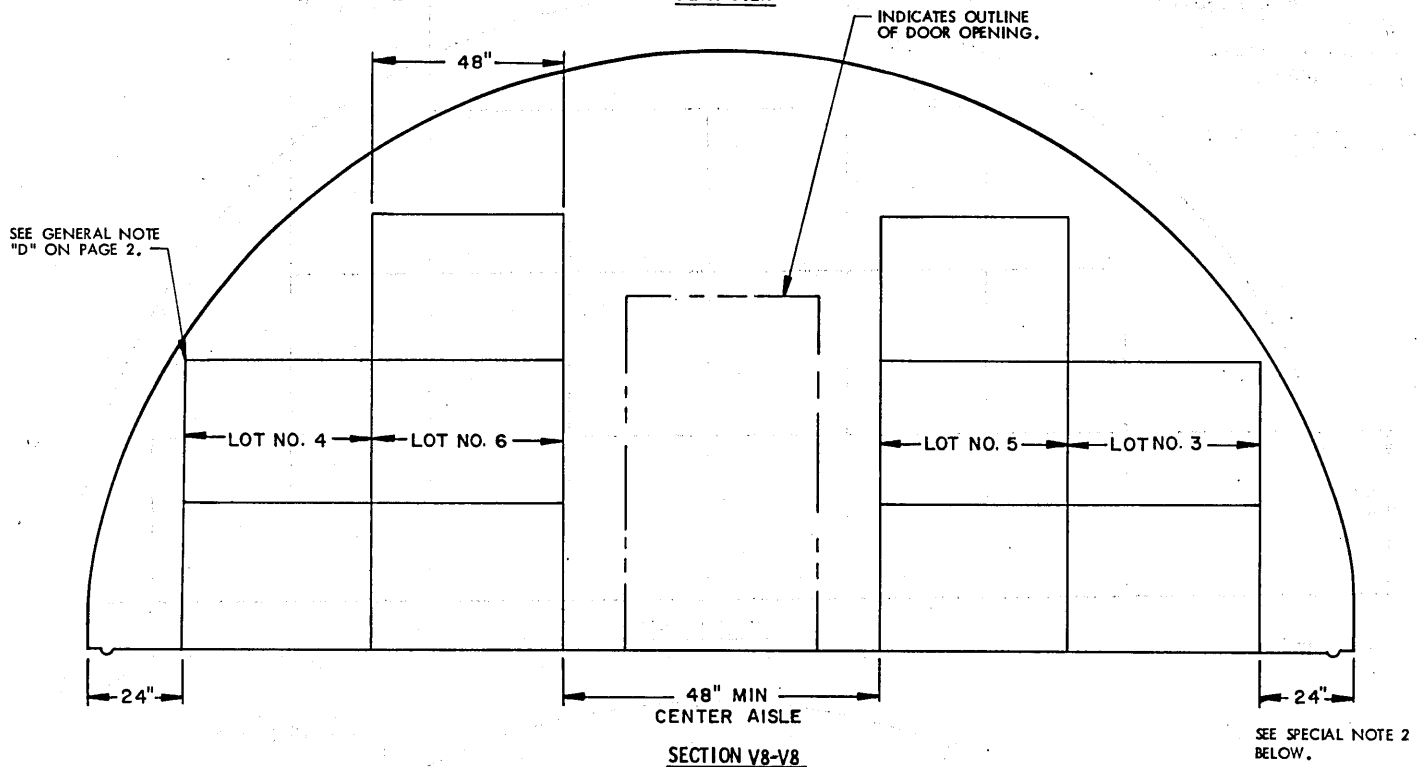

SECTION V8-V8

SPECIAL NOTES:

1. THE STORAGE PLANS AND CONFIGURATIONS SHOWN ON THIS PAGE ARE TYPICAL ONLY AND APPLY TO RELATIVELY LARGE LOTS. ADAPTATIONS MAY BE MADE AS NUMBER AND SIZES OF LOTS TO BE STORED IN MAGAZINE REQUIRE.
2. AN INSPECTION/INVENTORY AISLE MUST BE PROVIDED AT ONE SIDE OR END OF EACH LOT.
3. GENERALLY, THE LARGEST LOT SHOULD BE STORED IN THE REAR OF THE MAGAZINE. HOWEVER, THE REAR AREA MAY BE USED TO STORE MORE THAN ONE LOT BY ERECTING ROWS SIMILAR TO THOSE SHOWN IN THE FRONTAL AREA. A CENTER AISLE WILL NOT BE REQUIRED IN THE REAR AREA AS LONG AS EACH LOT IS ACCESSIBLE FOR REMOVAL AND INSPECTION/INVENTORY IN ACCORDANCE WITH OTHER CRITERIA SPECIFIED IN THESE SPECIAL NOTES AND IN THE GENERAL NOTES ON PAGE 2.
4. EACH LOT WITHIN THE MAGAZINE MUST BE ACCESSIBLE FOR MOVEMENT BY MHE. A SINGLE-LOT OF PALLET UNITS IS CONSIDERED "ACCESSIBLE" IF NOT MORE THAN TWELVE (12) "LIFTS" OF ANOTHER LOT OR LOTS HAVE TO BE MADE TO GAIN ACCESS TO THAT LOT. A "LIFT" MAY CONSIST OF ONE (1) OR MORE PALLET UNITS, PROVIDING THE CAPACITY OF MHE PERMITS, AND SAFE HANDLING IS NOT JEOPARDIZED.
5. FOR STORAGE OF MULTIPLE LOTS, THE DISTANCE FROM THE SIDEWALL WILL BE BASED ON THE OVERHEAD CLEARANCE REQUIRED FOR MHE.
6. WHEN TWO LOTS ARE STORED ADJACENT TO EACH OTHER, THEY SHOULD BE SEPARATED BY AT LEAST 1" TO PROVIDE CLEARANCE FOR REMOVAL OF EITHER LOT.

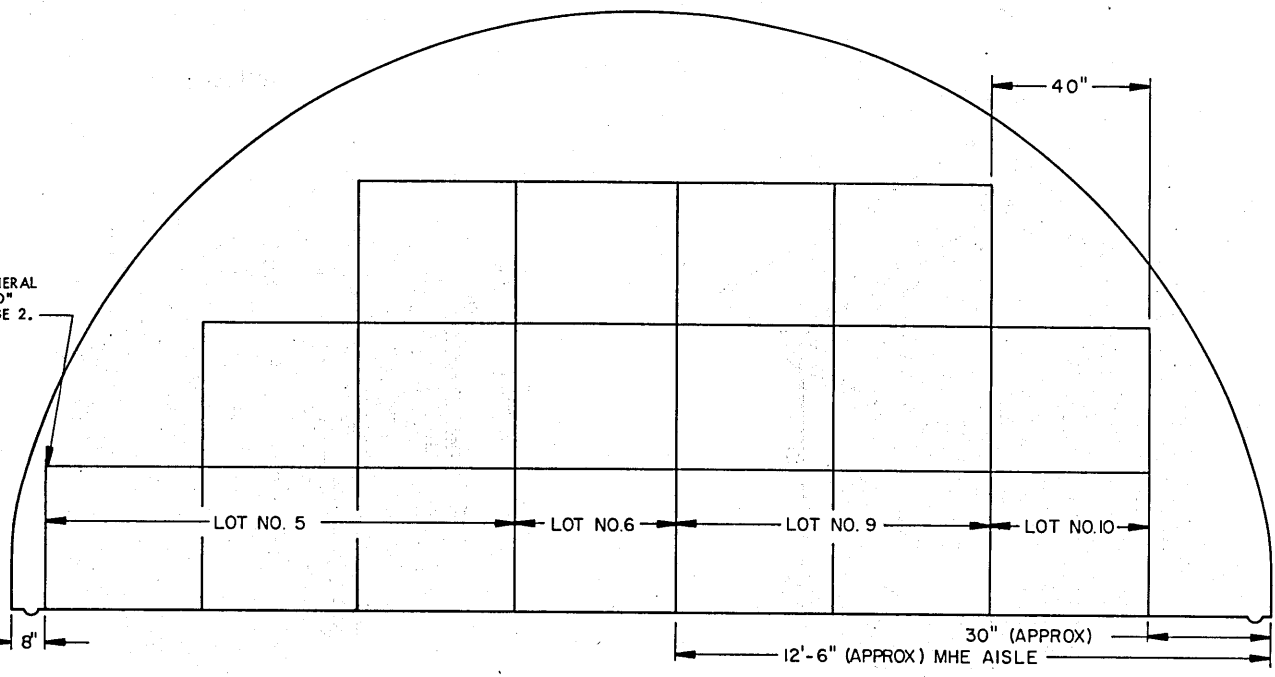
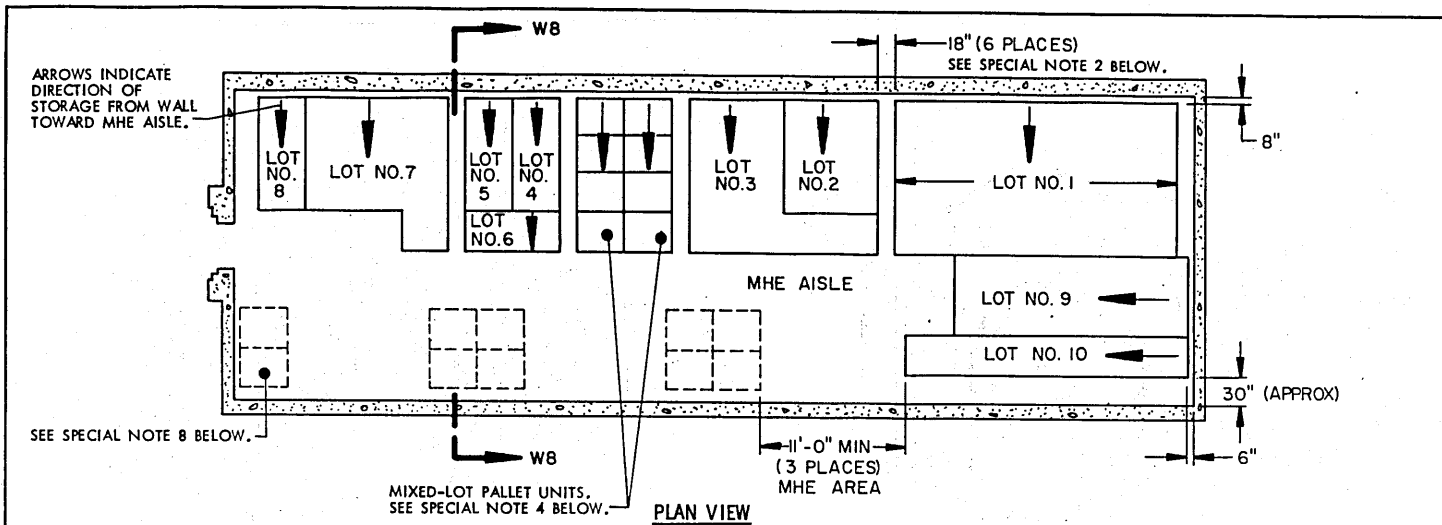

SECTION W8-W8

SPECIAL NOTES:

1. THE STORAGE PLANS AND CONFIGURATIONS SHOWN ON THIS PAGE ARE TYPICAL ONLY AND APPLY TO STORAGE OF NUMEROUS SMALL LOTS. ADAPTATIONS MAY BE MADE AS NUMBER AND SIZES OF LOTS TO BE STORED IN MAGAZINE REQUIRE.
2. AN INSPECTION/INVENTORY AISLE NOT LESS THAN 18" WIDE MUST BE PROVIDED AT ONE SIDE OR END OF EACH LOT.
3. GENERALLY, THE LARGEST LOT SHOULD BE STORED IN THE REAR OF THE MAGAZINE. HOWEVER, THE REAR AREA MAY BE USED TO STORE MORE THAN ONE LOT BY ERECTING STACKS SIMILAR TO THOSE SHOWN IN THE FRONTAL AREA. AN MHE AISLE WILL BE REQUIRED ON ONE SIDE OF THE MAGAZINE, AND EACH LOT MUST BE ACCESSIBLE FOR REMOVAL AND INSPECTION/INVENTORY IN ACCORDANCE WITH OTHER CRITERIA SPECIFIED IN THESE SPECIAL NOTES AND IN THE GENERAL NOTES ON PAGE 2.
4. A MIXED-LOT PALLET UNIT MAY HAVE FROM TWO LOTS PER PALLET UNIT UPWARDS TO AS MANY DIFFERENT LOTS AS PROPPELLING CHARGES WITHIN THAT UNIT. HOWEVER, ALL PROPPELLING CHARGES AND LOTS WITHIN THE PALLET UNIT MUST HAVE THE SAME NATIONAL STOCK NUMBER AND CONDITION CODE.
5. EACH LOT WITHIN THE MAGAZINE MUST BE ACCESSIBLE FOR MOVEMENT BY MHE. PALLET UNITS OF A SINGLE-LOT OR MIXED-LOT PALLET UNITS ARE CONSIDERED "ACCESSIBLE" IF NO MORE THAN TWELVE (12) "LIFTS" OF ANOTHER LOT OR LOTS HAVE TO BE MADE TO GAIN ACCESS TO THE SINGLE-LOT OR MIXED-LOT UNITS. A "LIFT" MAY CONSIST OF ONE (1) OR MORE PALLET UNITS, PROVIDING THE CAPACITY OF MHE PERMITS, AND SAFE HANDLING IS NOT JEOPARDIZED.
6. FOR STORAGE OF MULTIPLE LOTS, THE DISTANCE FROM THE SIDEWALL WILL BE BASED ON THE OVERHEAD CLEARANCE REQUIRED FOR MHE.

(SPECIAL NOTES CONTINUED)

7. WHEN TWO LOTS ARE STORED ADJACENT TO EACH OTHER, THEY SHOULD BE SEPARATED BY AT LEAST 1" TO PROVIDE CLEARANCE FOR REMOVAL OF EITHER LOT.
8. AREAS ENCLOSED BY DOTTED LINES INDICATE LOCATIONS WHERE ADDITIONAL LOTS MAY BE STORED OR WHERE ADDITIONAL ITEMS MAY BE STORED, THAT ARE FROM THE LOT OR LOTS WHICH ARE DIRECTLY OR ALMOST DIRECTLY ACROSS THE CENTER AISLE ON THE OTHER SIDE OF THE MAGAZINE. COMPLIANCE WITH ALL OF THE MULTIPLE-LOT CRITERIA AS SET FORTH ON THIS PAGE MUST BE OBSERVED. THE SIZE OF THE LOTS BEING STORED AND THE CRITERIA OF SPECIAL NOTE 5, RELATIVE TO "12 LIFTS", WILL BE MAJOR FACTORS IMPACTING ON THE NUMBER OF UNIT LOADS THAT CAN BE STORED IN AN "ADDITIONAL STORAGE LOCATION". MORE OR FEWER STACKS THAN SHOWN MAY BE STORED AT ANY ONE OF THE ADDITIONAL STORAGE LOCATIONS. AN 11-FOOT MHE OPERATING AREA HAS BEEN SPECIFIED FOR ACCESS TO EACH "ADDITIONAL LOCATION" BY FORKLIFT TRUCK. THIS OPERATING AREA IS BASED ON REQUIREMENTS OF FORKLIFT TRUCKS COMMONLY USED IN STORAGE MAGAZINES. THE MHE OPERATING AREA CAN BE ENLARGED AS REQUIRED TO SUIT AVAILABLE FORKLIFT TRUCKS, AND SHOULD BE MADE SMALLER IF AVAILABLE MHE PERMITS. A "CENTER AISLE" (SPACE BETWEEN STORAGE ON ONE SIDE OF A MAGAZINE AND AN "ADDITIONAL STORAGE LOCATION") IS TO BE AT LEAST 48 INCHES WIDE. AN AISLE SLIGHTLY WIDER THAN 48 INCHES WILL ENHANCE FORKLIFT TUCK MOVEMENT WITHIN A MAGAZINE; HOWEVER, THIS AISLE SHOULD NOT BE MADE WIDER IF A LOSS IN STORAGE RESULTS.

(CONTINUED AT RIGHT)

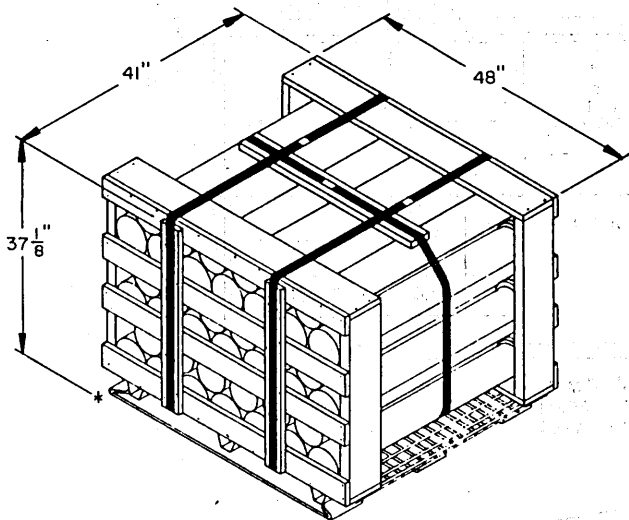

UNIT NO. 1

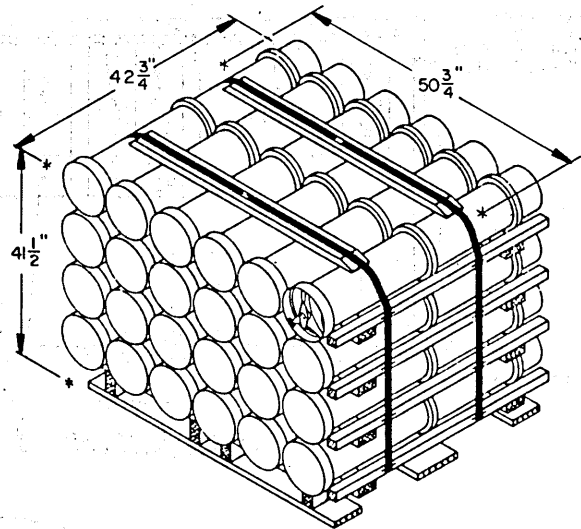

UNIT NO. 2

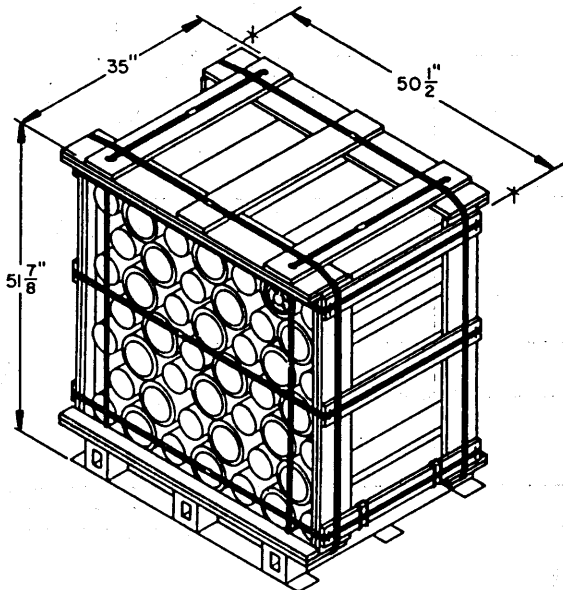

UNIT NO. 3

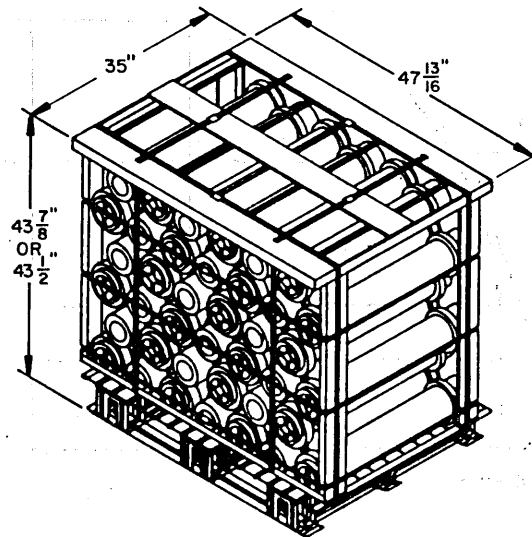

UNIT NO. 4

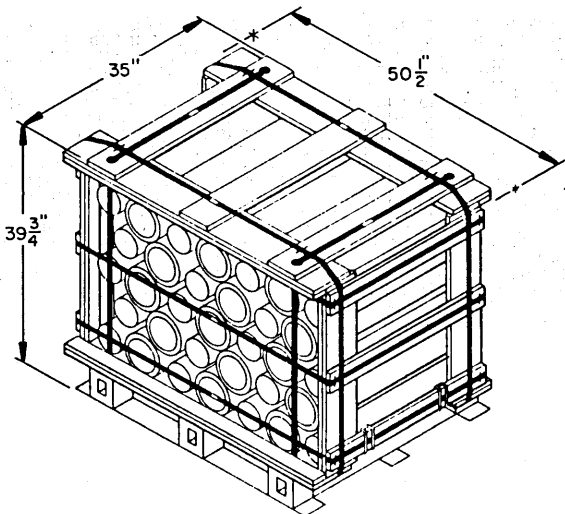

UNIT NO. 5

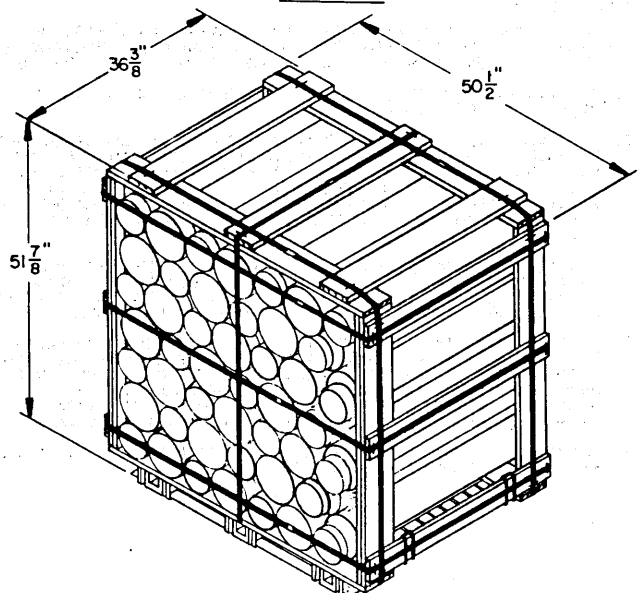

UNIT NO. 6

PALLET UNIT DETAILS

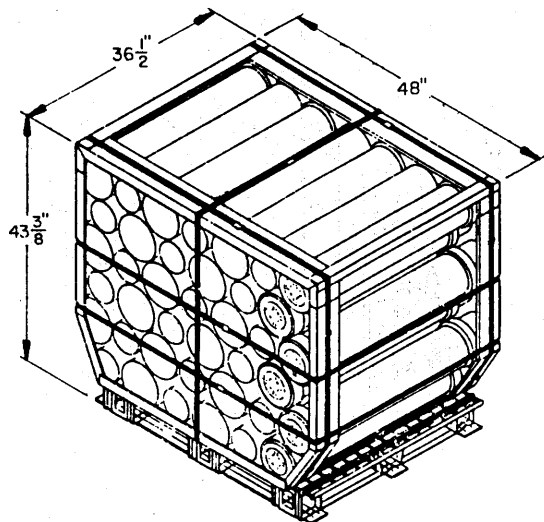

UNIT NO. 7

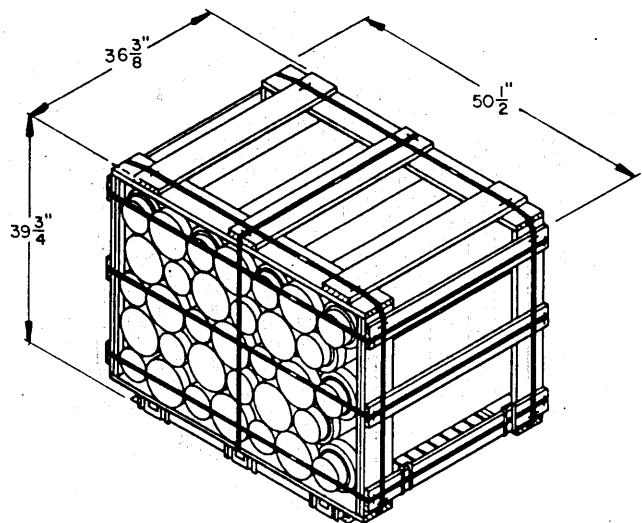

UNIT NO. 8

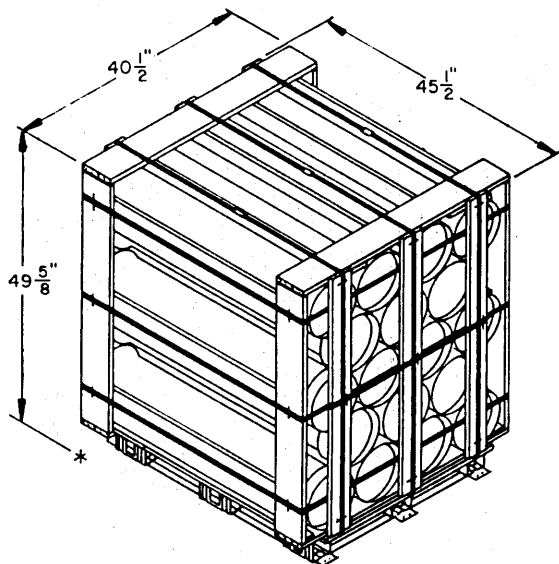

UNIT NO. 9

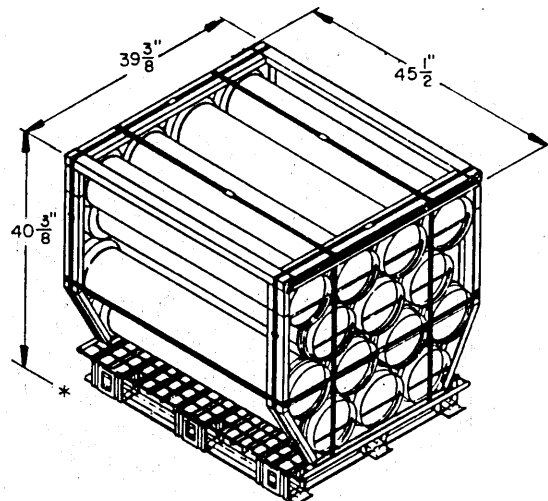

UNIT NO. 10

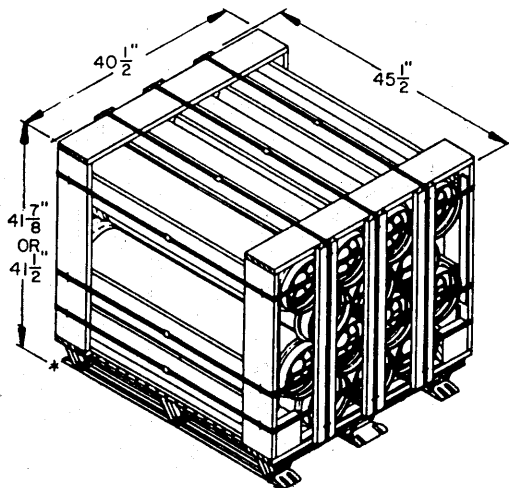

UNIT NO. 11

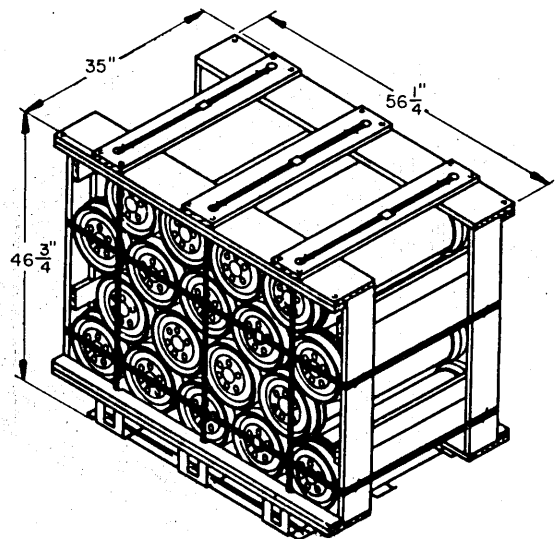

UNIT NO. 12

PALLET UNIT DETAILS

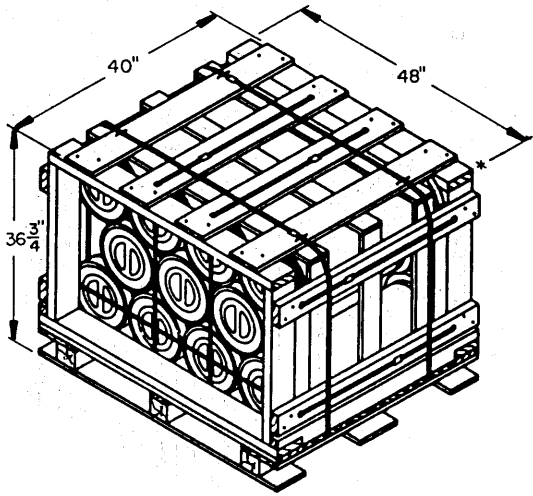

UNIT NO. 13

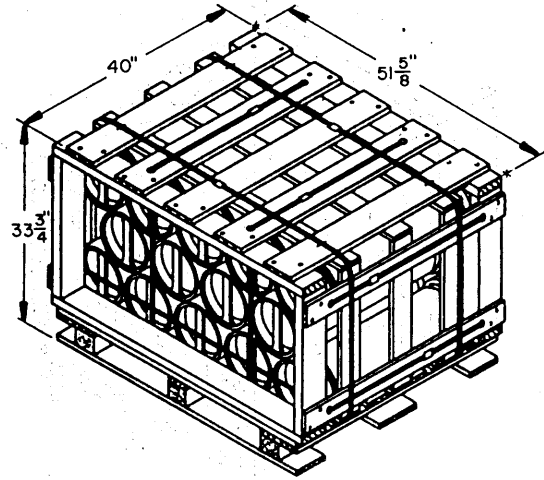

UNIT NO. 14

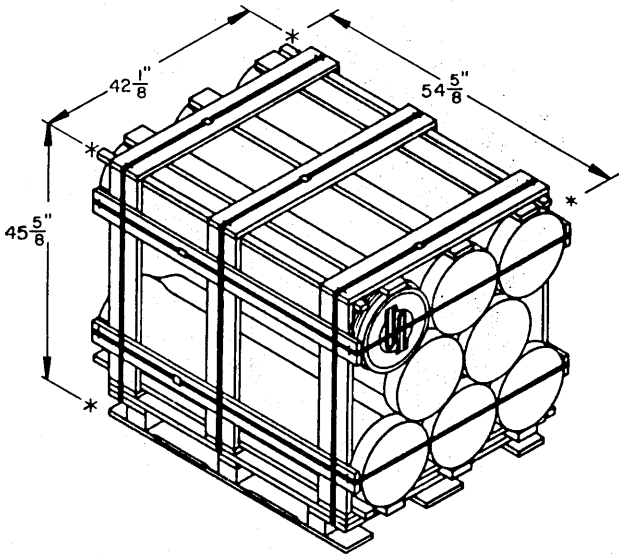

UNIT NO. 15

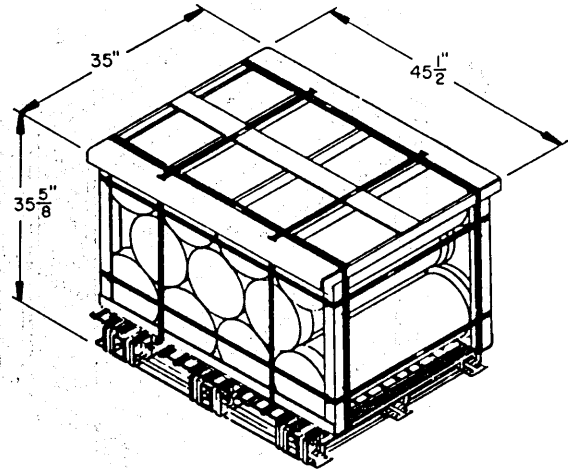

UNIT NO. 16

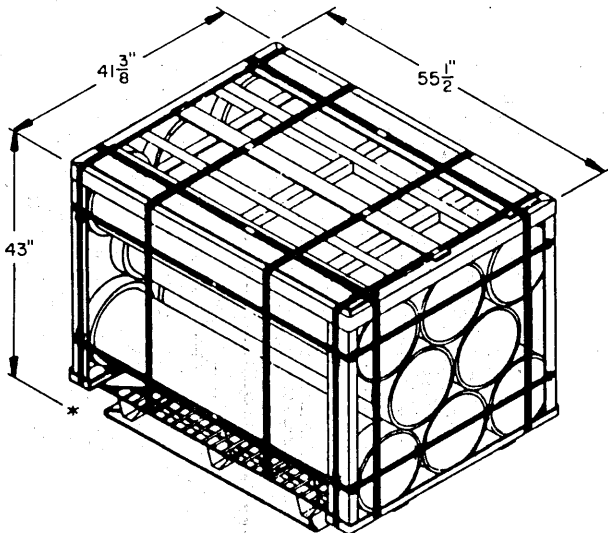

UNIT NO. 17

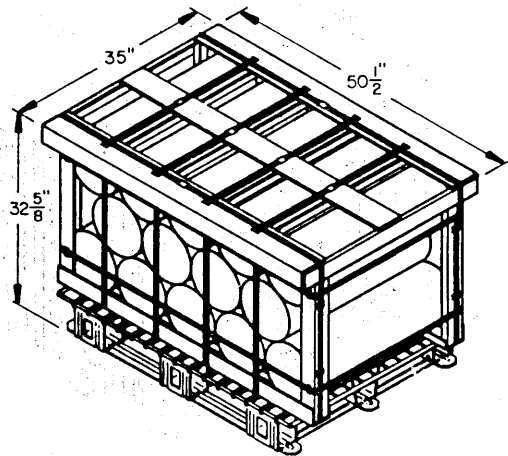

UNIT NO. 18

PALLET UNIT DETAILS

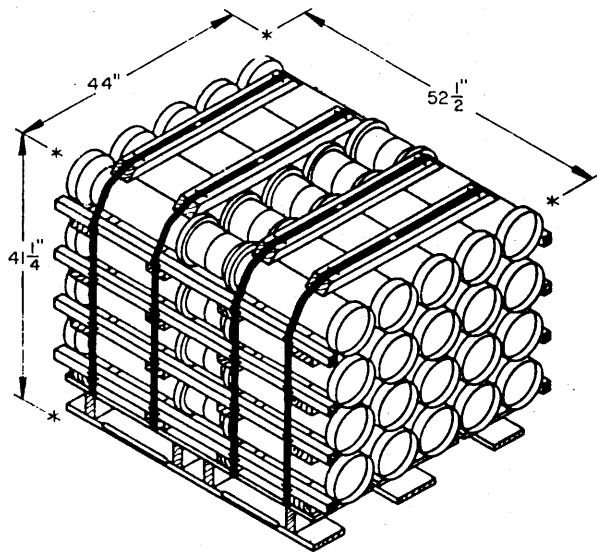

UNIT NO. 19

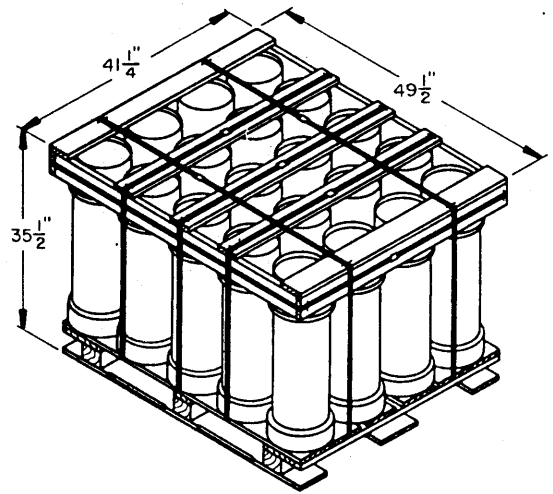

UNIT NO. 20

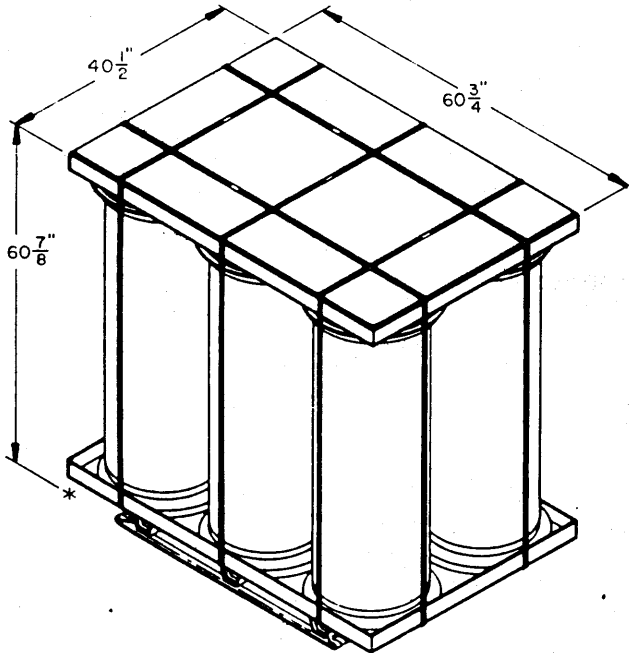

UNIT NO. 21

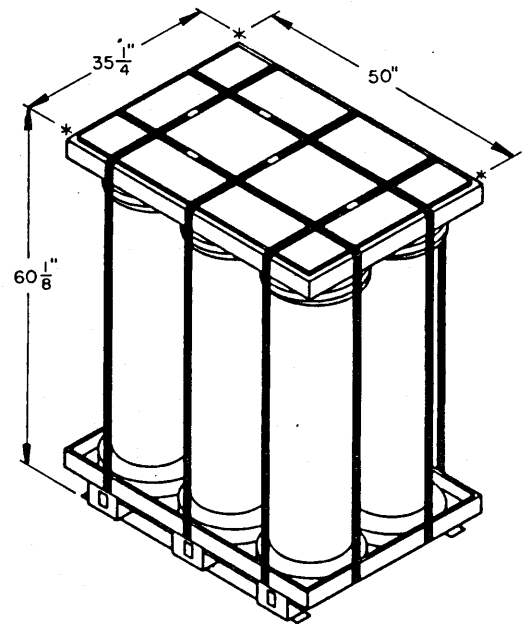

UNIT NO. 22

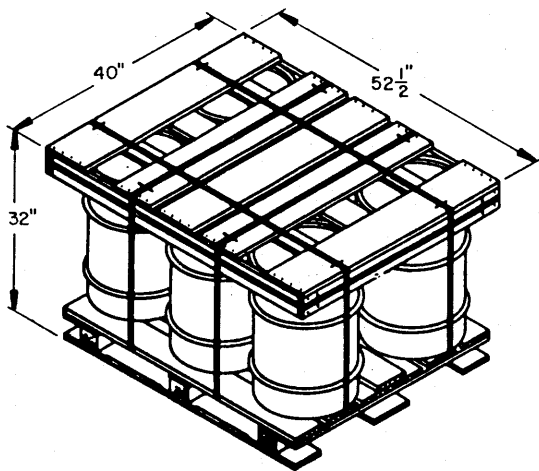

UNIT NO. 23

PALLET UNIT DETAILS

INTENTIONALLY LEFT BLANK
FOR UNITS 25 THRU 30

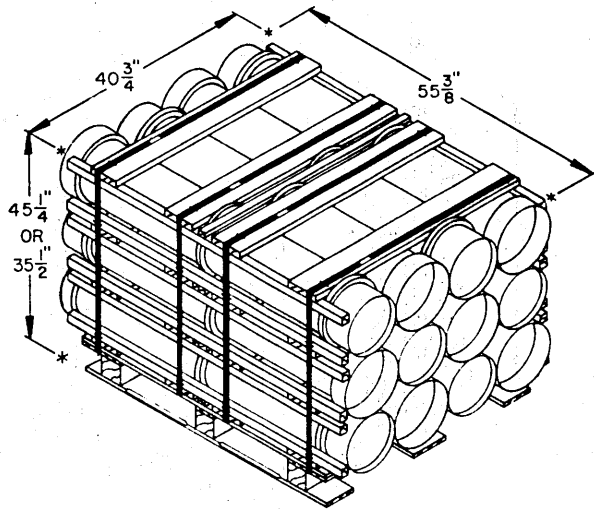

UNIT NO. 31

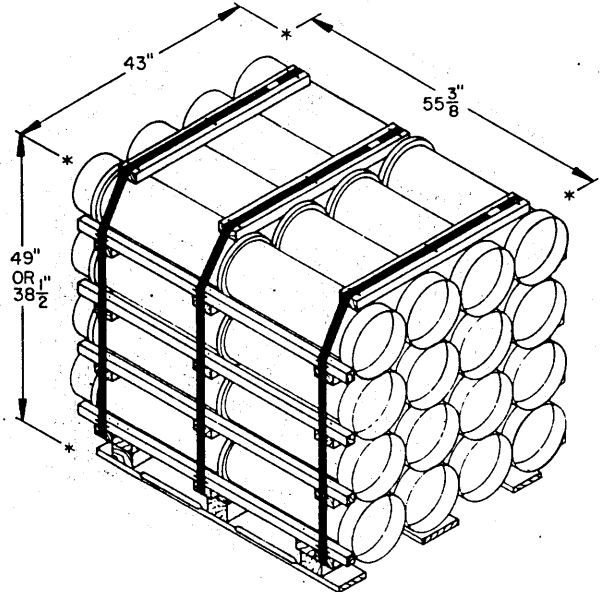

UNIT NO. 32

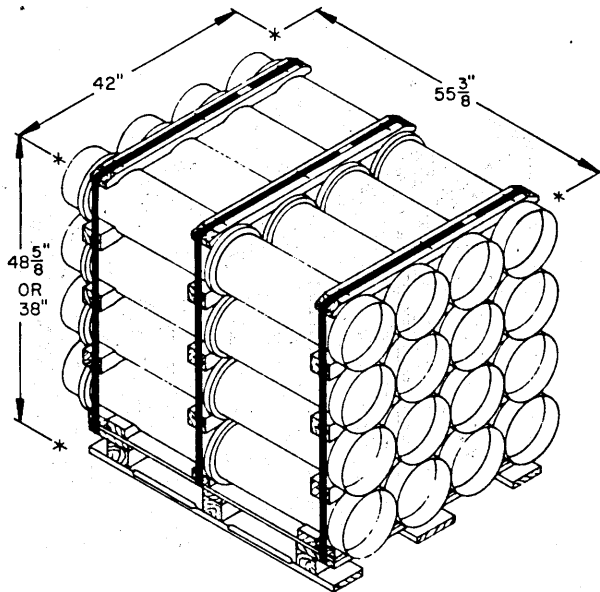

UNIT NO. 33

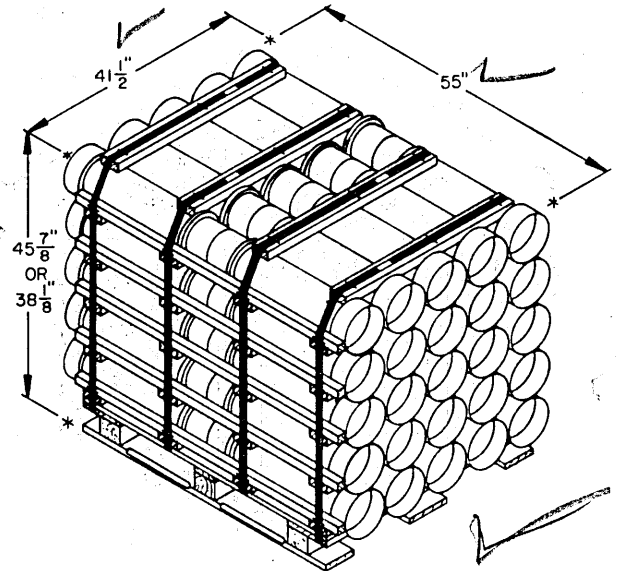

UNIT NO. 34

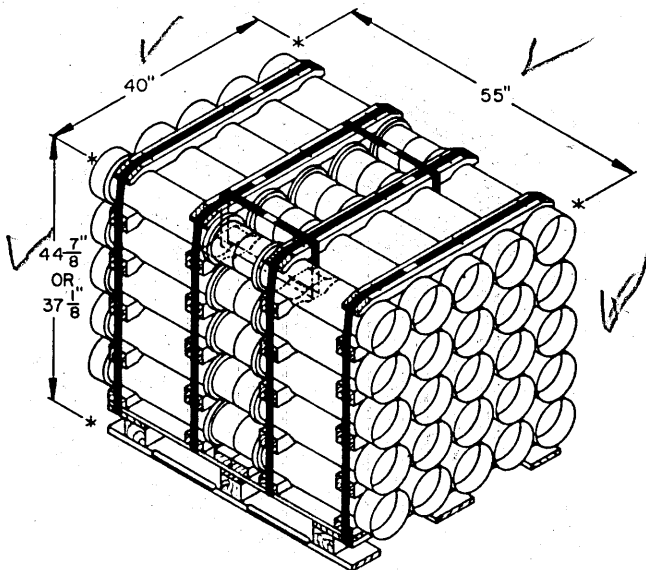

UNIT NO. 35

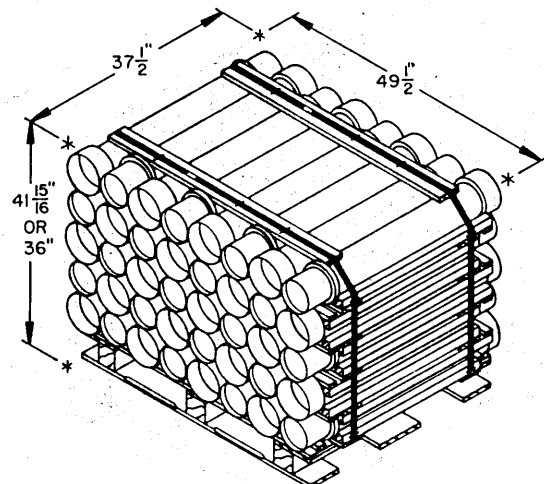

UNIT NO. 36

PALLET UNIT DETAILS

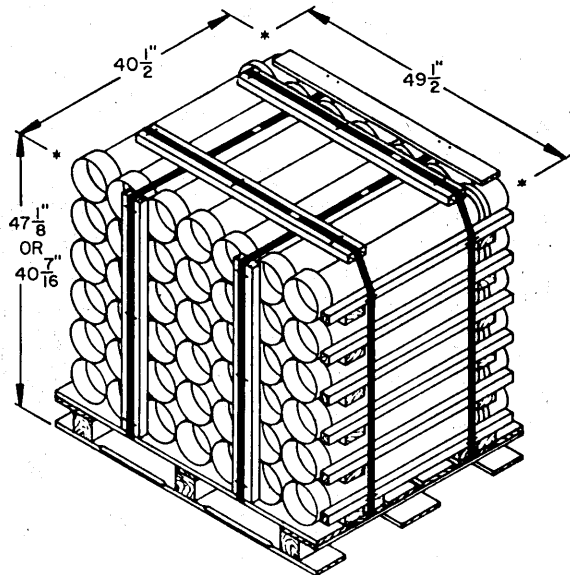

UNIT NO. 37

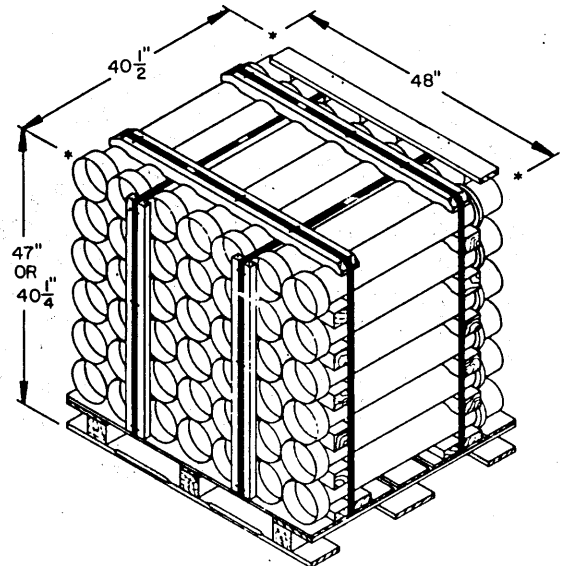

UNIT NO. 38

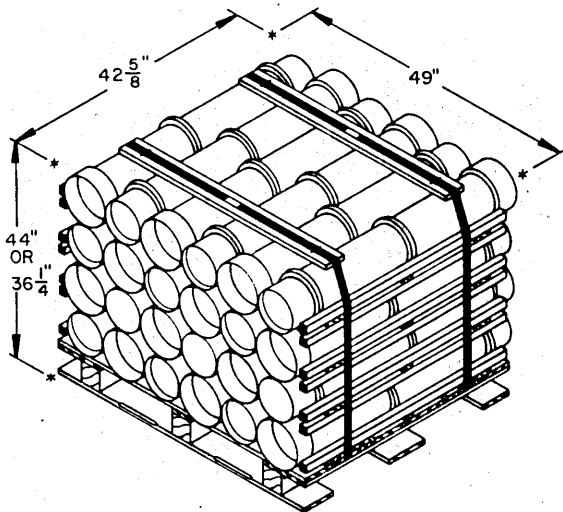

UNIT NO. 39

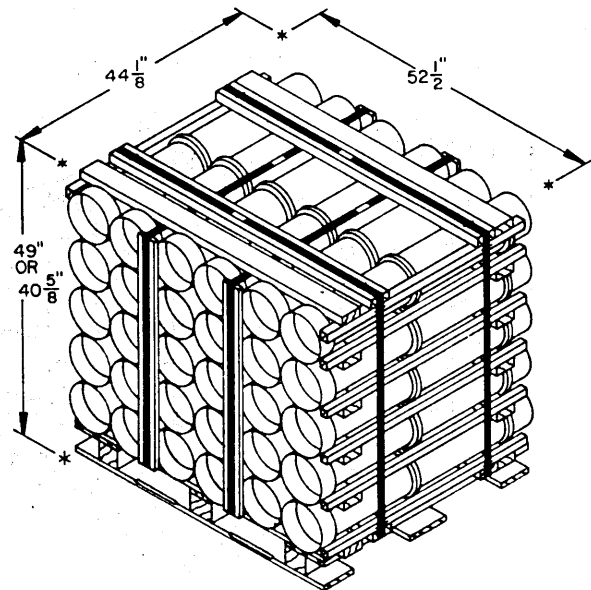

UNIT NO. 40

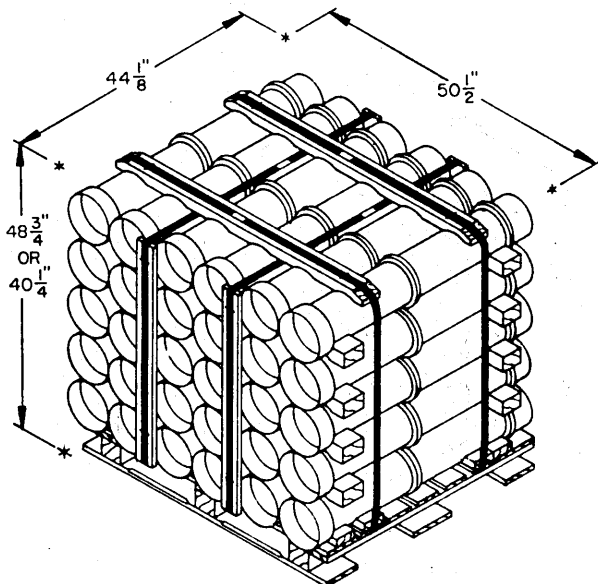

UNIT NO. 41

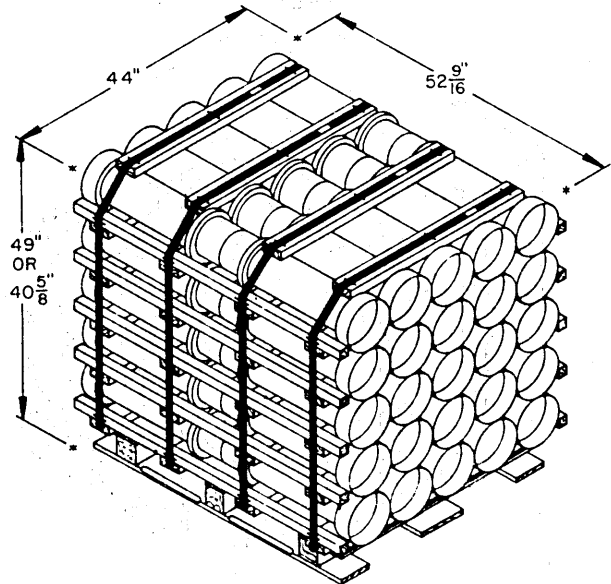

UNIT NO. 42

PALLET UNIT DETAILS

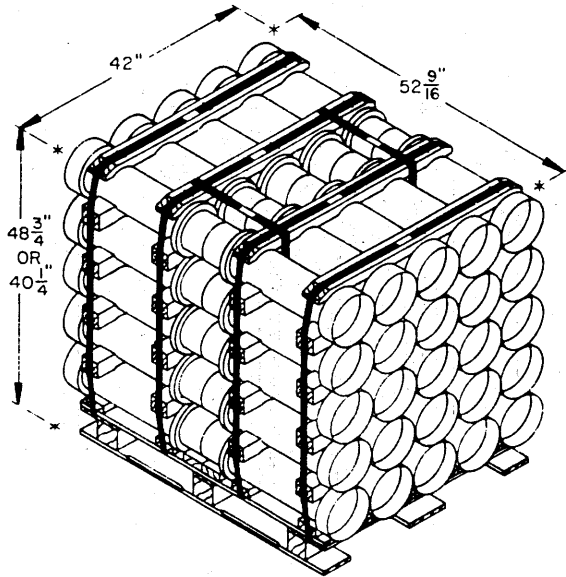

UNIT NO. 43

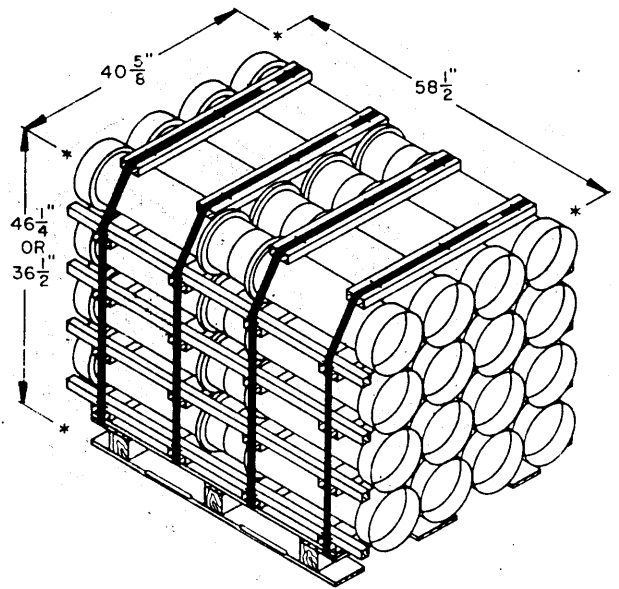

UNIT NO. 44

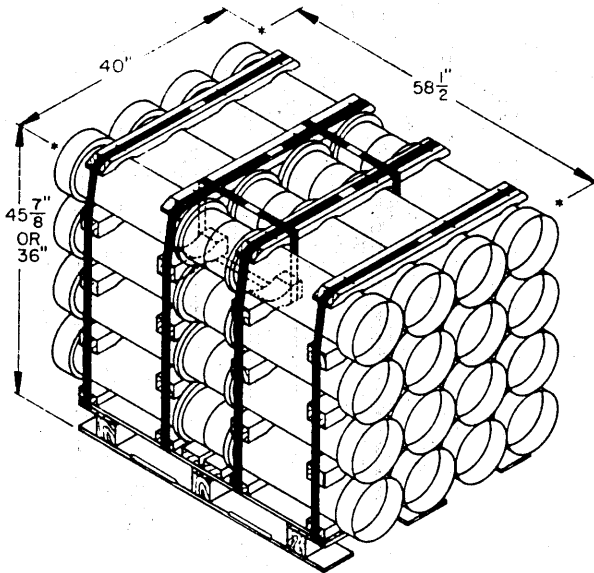

UNIT NO. 45

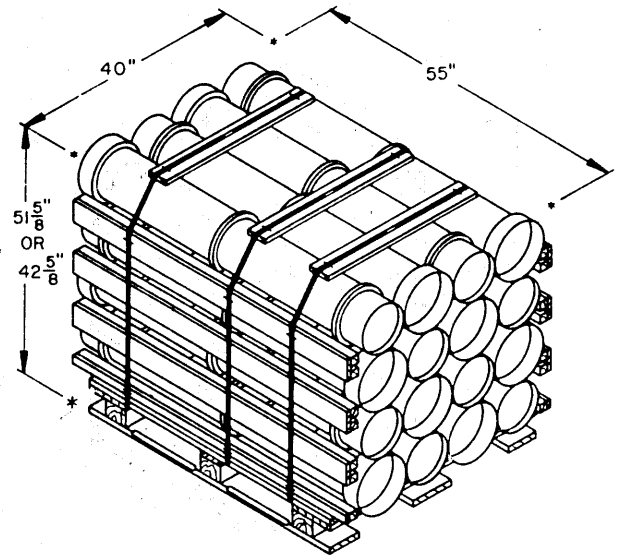

UNIT NO. 46

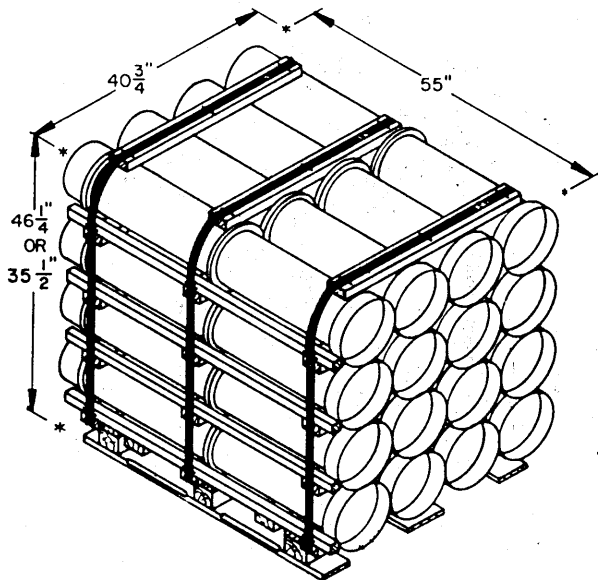

UNIT NO. 47

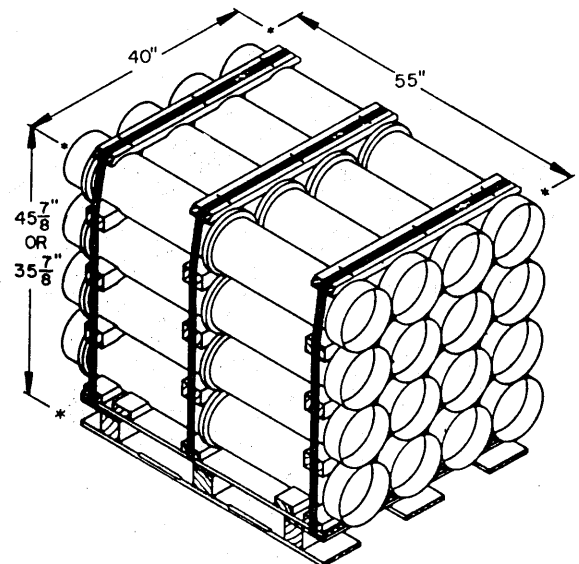

UNIT NO. 48

PALLET UNIT DETAILS

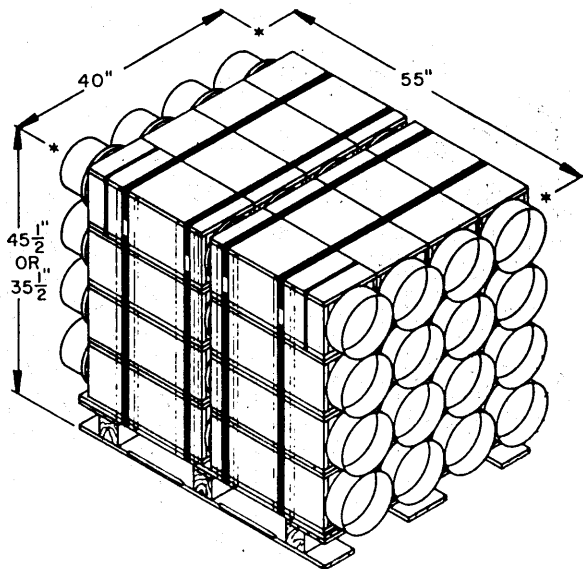

UNIT NO. 49

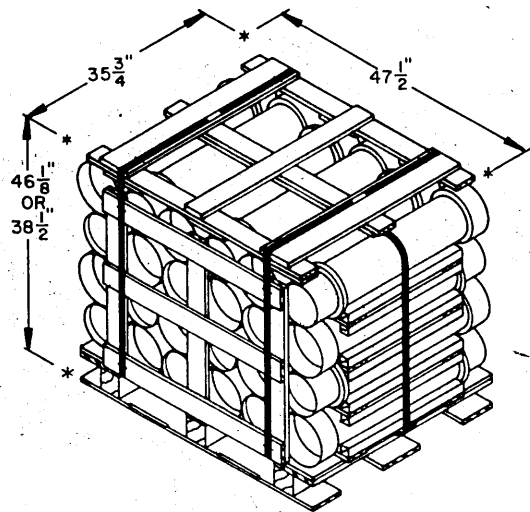

UNIT NO. 50

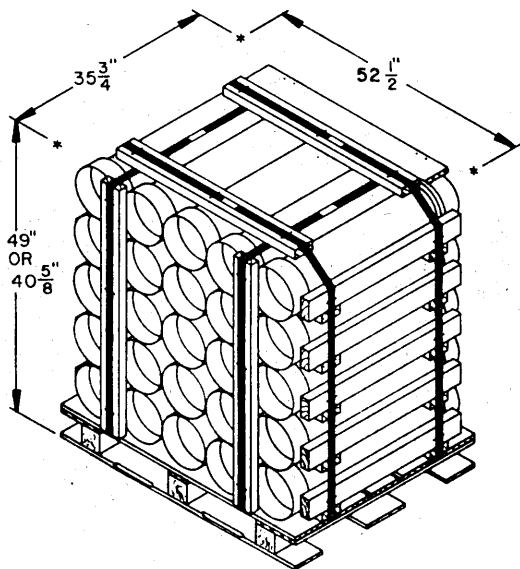

UNIT NO. 51

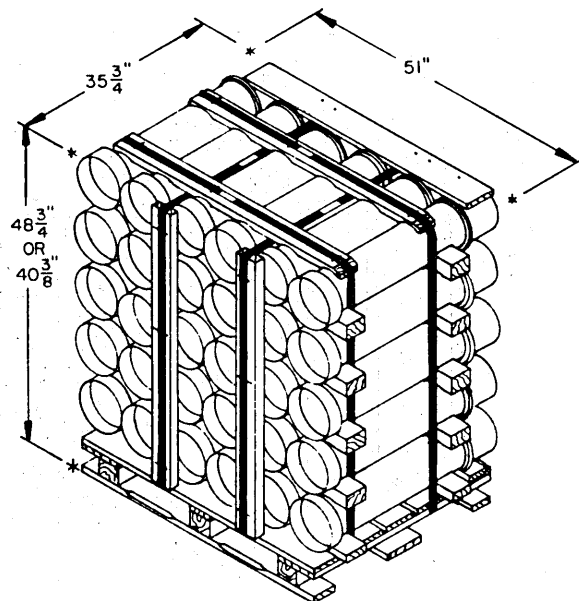

UNIT NO. 52

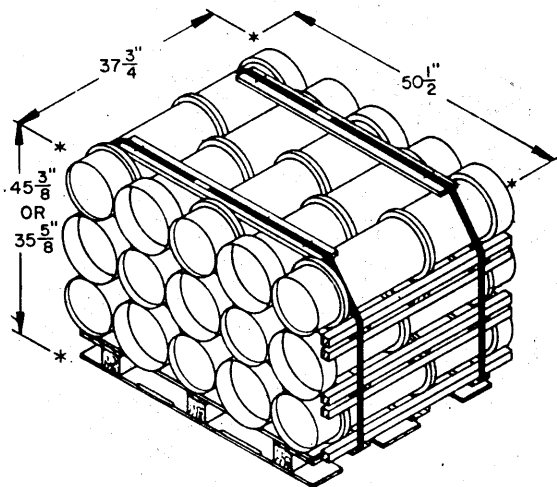

UNIT NO. 53

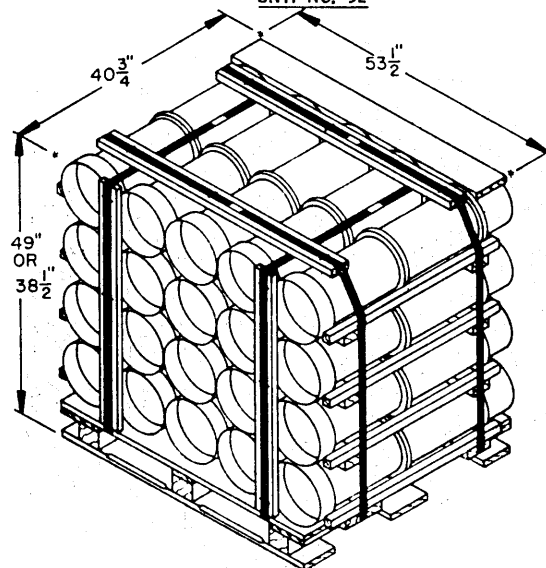

UNIT NO. 54

PALLET UNIT DETAILS

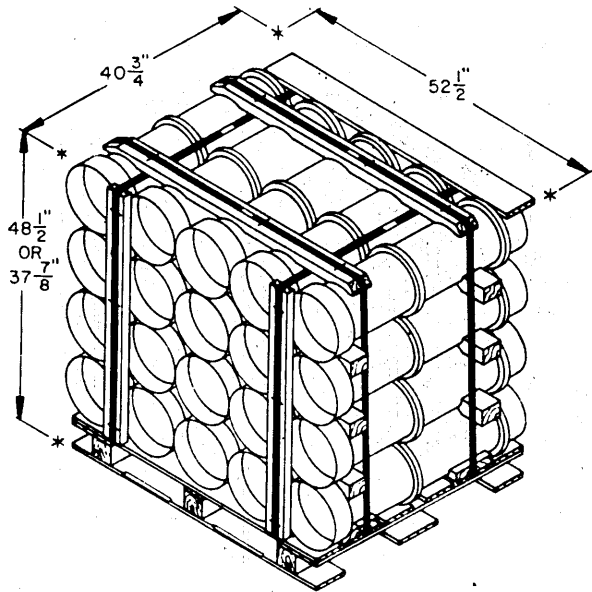

UNIT NO. 55

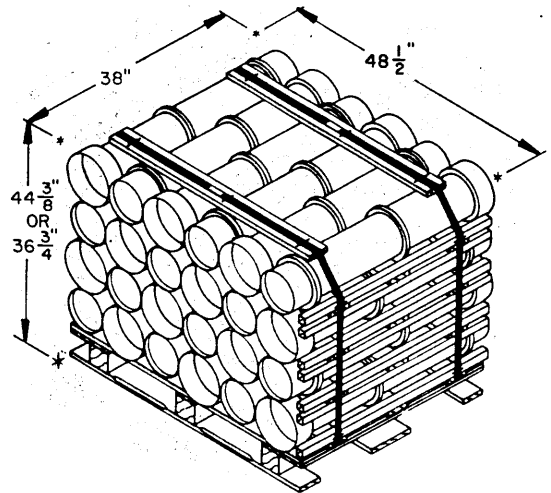

UNIT NO. 56

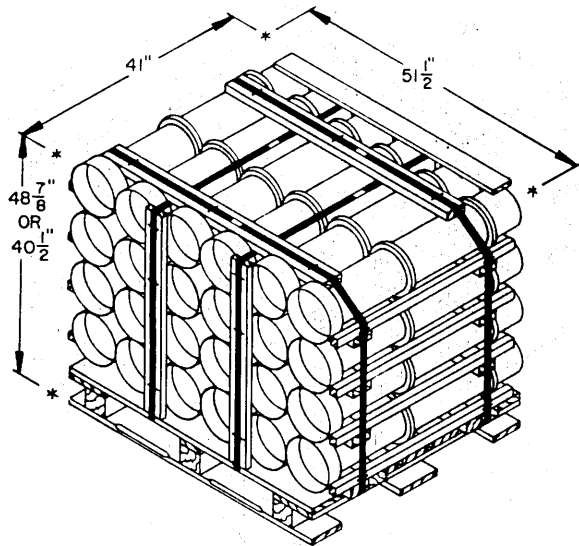

UNIT NO. 57

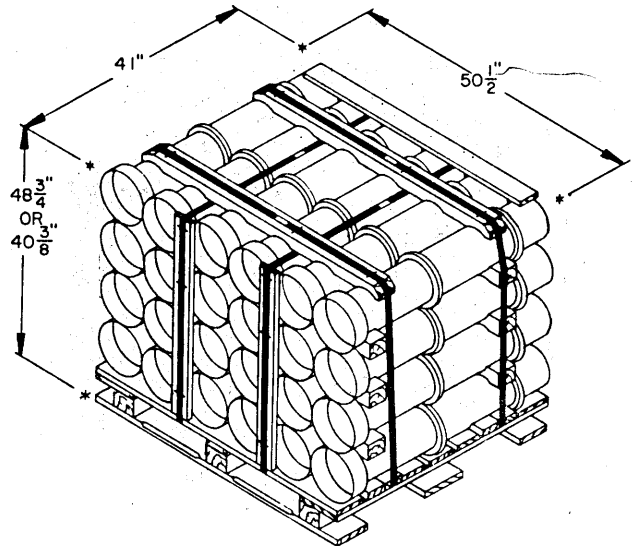

UNIT NO. 58

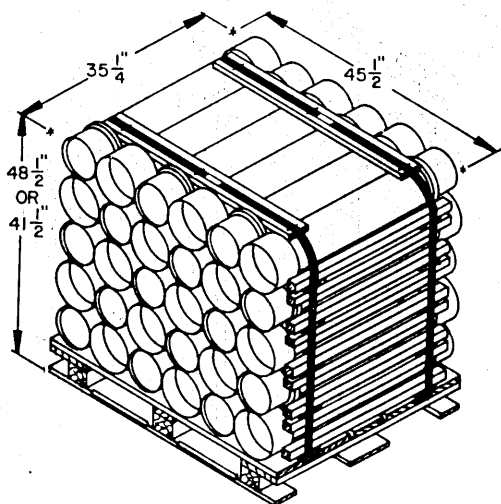

UNIT NO. 59

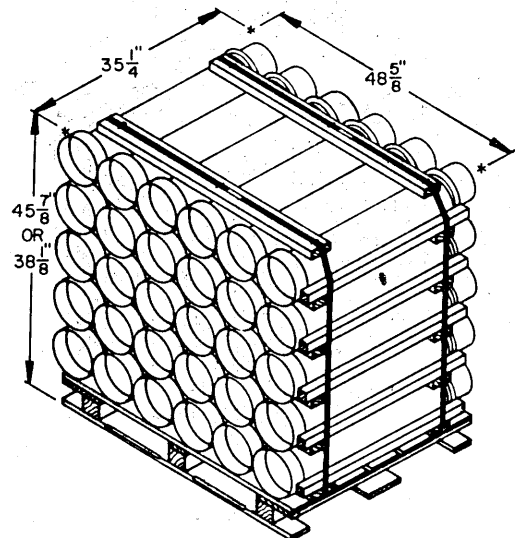

UNIT NO. 60

PALLET UNIT DETAILS

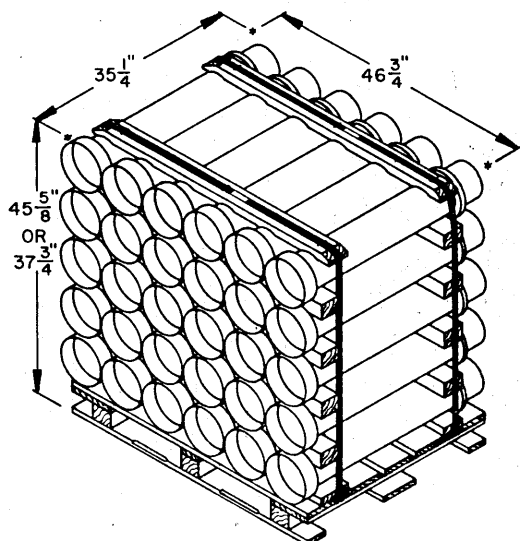

UNIT NO. 61

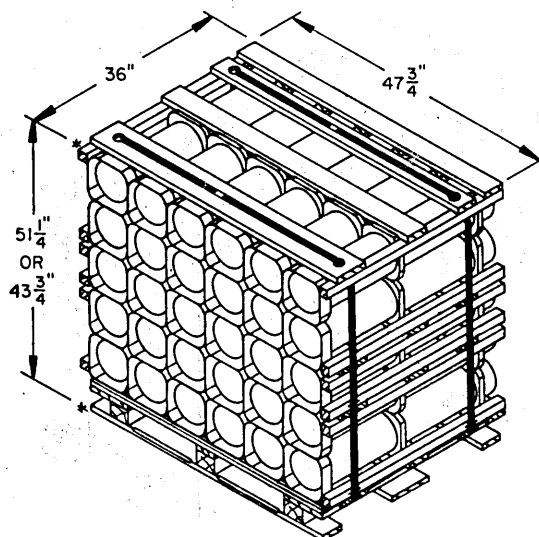

UNIT NO. 62

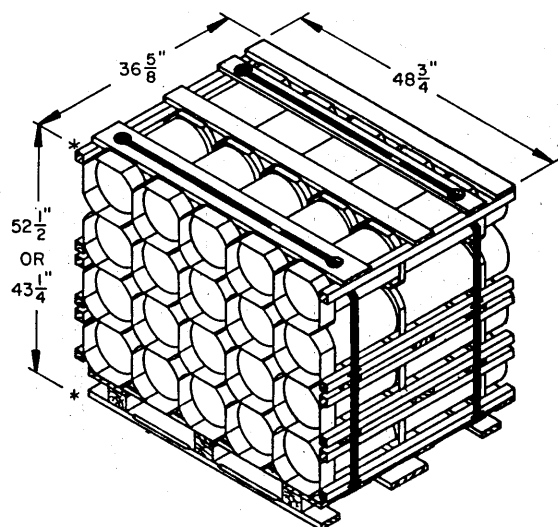

UNIT NO. 63

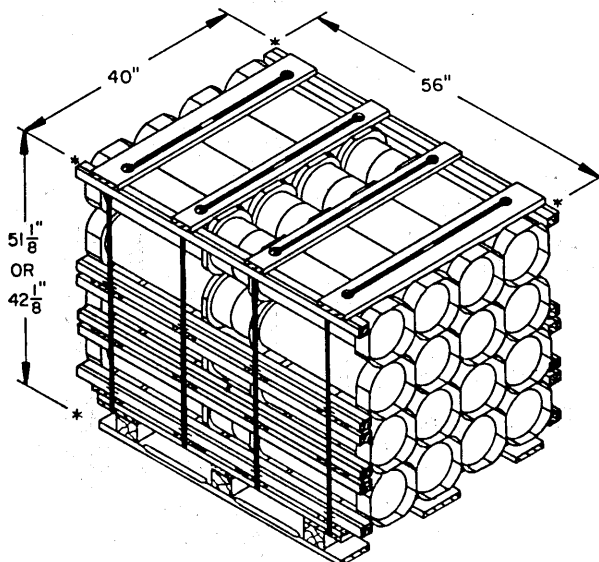

UNIT NO. 64

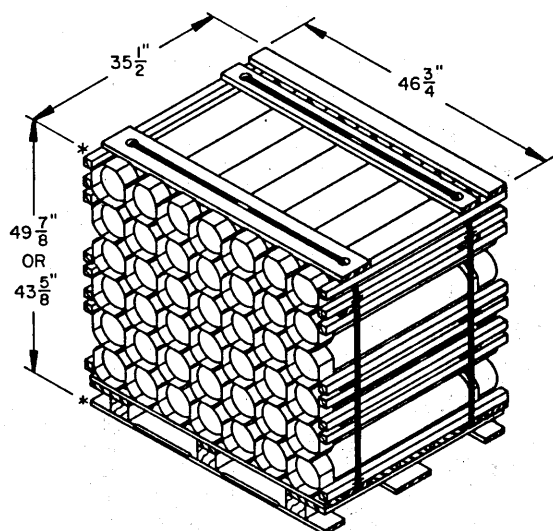

UNIT NO. 65

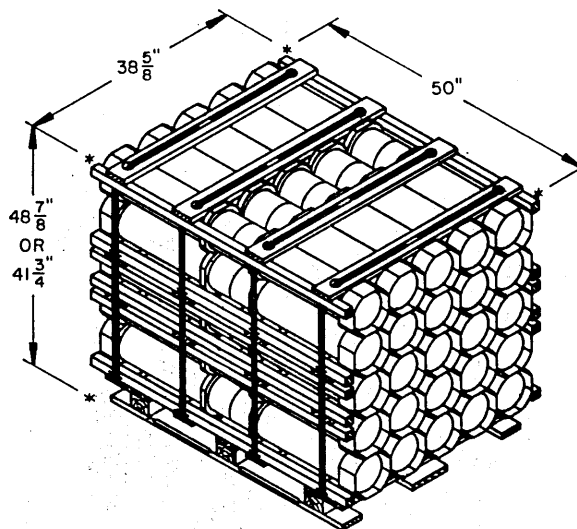

UNIT NO. 66

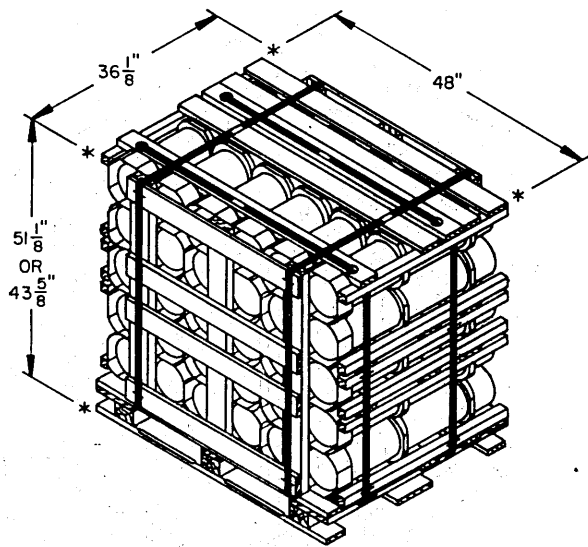

UNIT NO. 67

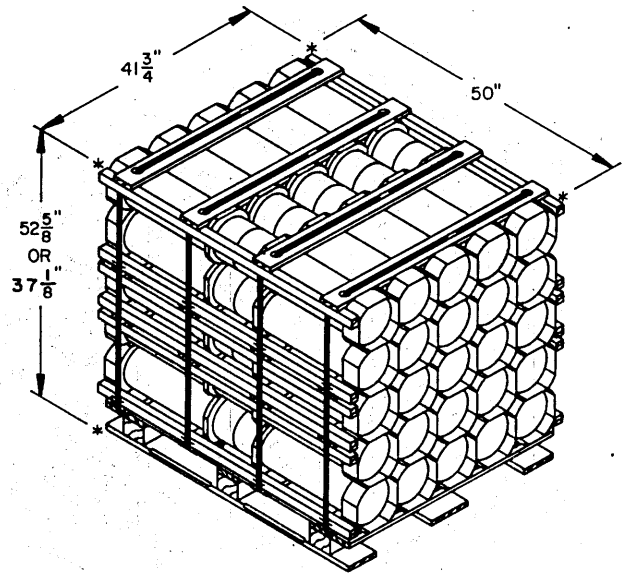

UNIT NO. 68

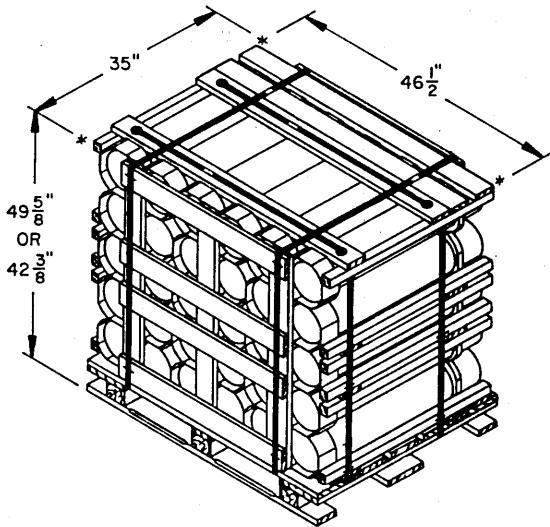

UNIT NO. 69

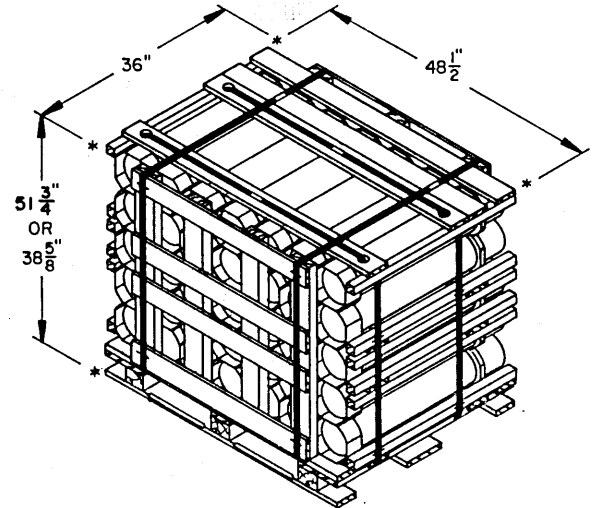

UNIT NO. 70

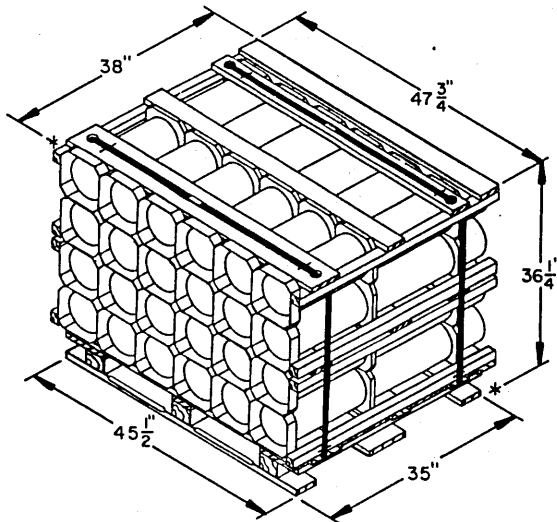

UNIT NO. 71

PALLET UNIT DETAILS

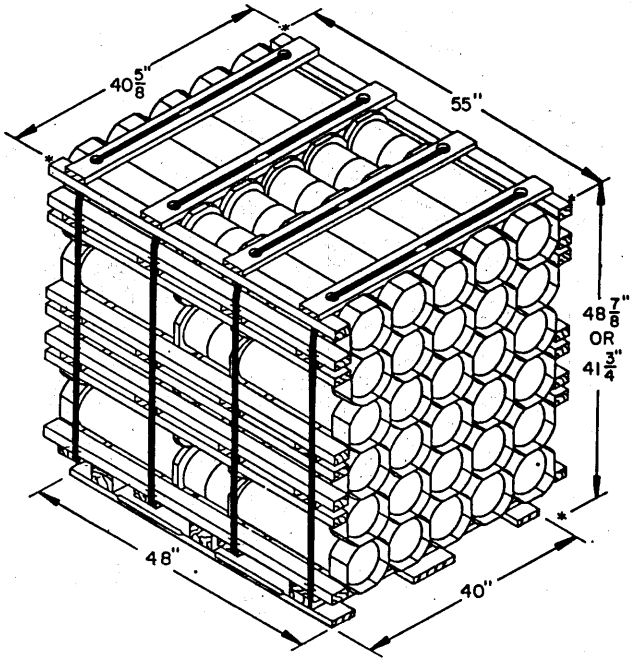

UNIT NO. 72

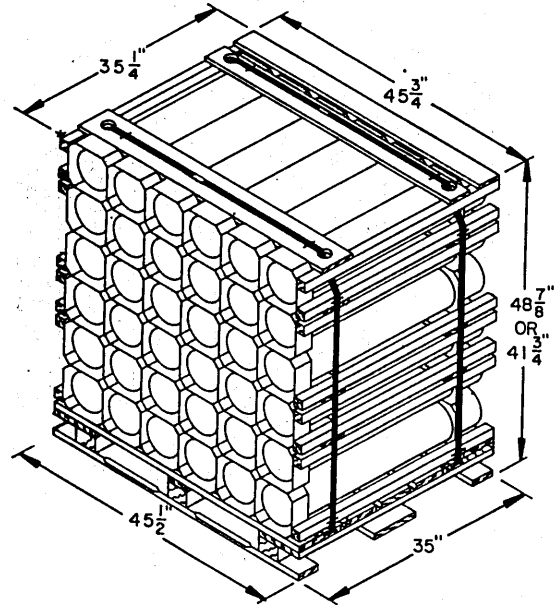

UNIT NO. 73

THIS PAGE INTENTIONALLY LEFT BLANK

ITEMIZED INDEX (CONTINUED FROM PAGE 3)

LINE NO.*	ITEM IDENTIFICATION	PALLET UNIT DIMENSIONS L X W X H (INCHES)	UNIT WEIGHT (POUNDS)	LINE NO.	UNIT DETAIL PAGE	STORAGE DETAIL PAGE
97	PA93 CNTR, PALLET UNIT	40 X 56 X 51-1/8	2,137	64	134	102
98	PA93 CNTR, PALLET UNIT (DECREASED HEIGHT)	40 X 56 X 42-1/8	1,723	64	134	103
99	PA94 CNTR, PALLET UNIT	35-1/2 X 46-3/4 X 49-7/8	1,471	65	134	104
100	PA94 CNTR, PALLET UNIT (DECREASED HEIGHT)	35-1/2 X 46-3/4 X 43-5/8	1,269	65	134	105
101	PA95 CNTR, PALLET UNIT	38-5/8 X 50 X 48-7/8	1,839	66	134	106
102	PA95 CNTR, PALLET UNIT (DECREASED HEIGHT)	38-5/8 X 50 X 41-3/4	1,539	66	134	107
103	PA96 CNTR, PALLET UNIT	36-1/8 X 48 X 51-1/8	1,783	67	135	108
104	PA96 CNTR, PALLET UNIT (DECREASED HEIGHT)	36-1/8 X 48 X 43-5/8	1,498	67	135	109
105	PA97 CNTR, PALLET UNIT	41-3/4 X 50 X 52-5/8	1,919	68	135	110
106	PA97 CNTR, PALLET UNIT (DECREASED HEIGHT)	41-3/4 X 50 X 37-1/8	1,320	68	135	111
107	PA99 CNTR, PALLET UNIT	35 X 46-1/2 X 49-5/8	1,715	69	135	112
108	PA99 CNTR, PALLET UNIT (DECREASED HEIGHT)	35 X 46-1/2 X 42-3/8	1,442	69	135	113
109	PA100 CNTR, PALLET UNIT	36 X 48-1/2 X 51-3/4	1,478	70	135	114
110	PA100 CNTR, PALLET UNIT (DECREASED HEIGHT)	36 X 48-1/2 X 38-3/8	1,077	70	135	115
111	PA 106 CNTR, PALLET	38 X 47-3/4 X 36-1/4	1,370	71	135	116
112	PA 106 CNTR, PALLET UNIT	40-5/8 X 55 X 48-7/8	2,186	72	136	118
113	PA 106 CNTR, PALLET UNIT (DECREASED HEIGHT)	40-5/8 X 55 X 41-3/4	1,681	72	136	119
114	PA 107 CNTR, PALLET UNIT	35-1/4 X 45-3/4 X 48-7/8	1,540	73	136	120
115	PA 107 CNTR, PALLET UNIT (DECREASED HEIGHT)	35-1/4 X 45-3/4 X 41-3/4	1,407	73	136	121

THE PALLET UNITS LISTED ON THE EVEN NUMBERED LINES 98 THRU 110, AND 113 AND 115 ARE DECREASED HEIGHT UNITS, AS PERMITTED BY THE UNITIZATION DRAWINGS FOR EACH ITEM CONTAINER MODEL.