

# APPENDIX 87

## UNITIZATION PROCEDURES FOR BOXED AMMUNITION AND COMPONENTS ON SKIDDED BASES

MINE, ANTIPERSONNEL, PACKED 10 PER WOODEN  
BOX, UNITIZED 9 BOXES PER TYPE I OR  
TYPE II SKID BASE; APPROX BOX SIZE 32" L  
X 13 $\frac{1}{4}$ " W X 9 $\frac{1}{2}$ " H

SKIDDED UNIT DATA						
ITEMS INCLUDED		HAZARD CLASSIFICATION				WEIGHT (LBS)
NSN	DODIC	DOT CLASS	CG CLASS	QD CLASS	COMP GROUP	
1345-00-028-5082	K090	A	IV	(08)1.2	D	880
00-028-5083	K090	A	IV	(08)1.2	D	880

**NOTICE:** THIS APPENDIX CANNOT STAND ALONE BUT MUST BE USED IN CONJUNCTION WITH THE BASIC UNITIZATION PROCEDURES DRAWING 19-48-4138-20PA1000.

**DO NOT SCALE**

REVISIONS											
			<small>DRAFTSMAN</small> GRG/Max <small>CHECKER</small> RSW/GRG <small>PROJ. ENG.</small> WRF/NEW <small>LOG. ENGRG. OFFICER</small> J.H.S.								
			<small>APPROVED, U. S. ARMY ARMAMENT MATERIEL READINESS COMMAND</small> 994 Benton Daniel C. Fetter <small>DRBAR-MAD</small> <small>DRBAR-TMD</small>								
			<small>APPROVED BY ORDER OF COMMANDING GENERAL, U. S. ARMY MATERIEL DEVELOPMENT AND READINESS COMMAND (DARCOM)</small> John X. Raymond Jr. <small>U. S. ARMY DEFENSE AMMUNITION CENTER AND SCHOOL</small>								
			<b>U. S. ARMY DARCOM DRAWING</b> <b>JANUARY 1980</b>								
			<table border="1" style="width: 100%; border-collapse: collapse;"> <tr> <td style="width: 25%;"><small>CLASS</small></td> <td style="width: 25%;"><small>DIVISION</small></td> <td style="width: 25%;"><small>DRAWING</small></td> <td style="width: 25%;"><small>FILE</small></td> </tr> <tr> <td style="text-align: center;">19</td> <td style="text-align: center;">48</td> <td style="text-align: center;">4138/ 87</td> <td style="text-align: center;">20PA 1000</td> </tr> </table>	<small>CLASS</small>	<small>DIVISION</small>	<small>DRAWING</small>	<small>FILE</small>	19	48	4138/ 87	20PA 1000
<small>CLASS</small>	<small>DIVISION</small>	<small>DRAWING</small>	<small>FILE</small>								
19	48	4138/ 87	20PA 1000								

TIEDOWN STRAP, 3/4" X .035" OR .031" X 12'-6" LONG STEEL STRAPPING (2 REQD).

TIEDOWN STRAP (SKID), 3/4" X .035" OR .031" X 13'-4" LONG STEEL STRAPPING (2 REQD).

### GENERAL NOTES

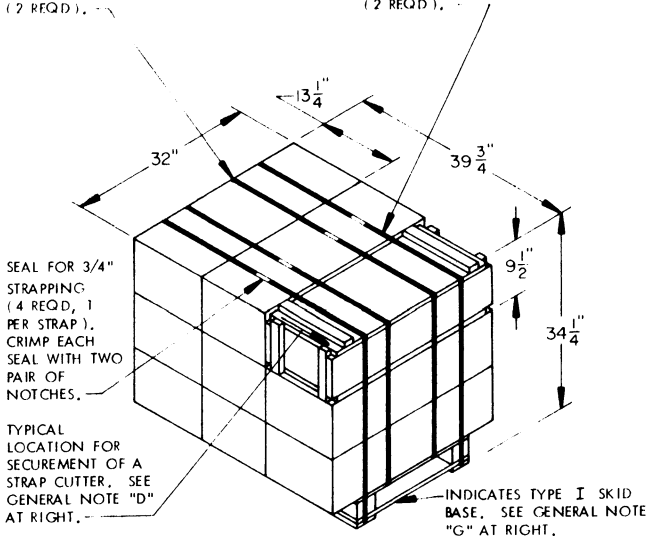

A. THIS APPENDIX CANNOT STAND ALONE BUT MUST BE USED IN CONJUNCTION WITH THE BASIC UNITIZATION PROCEDURES DRAWING 19-48-4138-20PA1000. TO PRODUCE AN APPROVED UNIT LOAD, ALL PERTINENT PROCEDURES, SPECIFICATIONS AND CRITERIA SET FORTH WITHIN THE BASIC DRAWING WILL APPLY TO THE PROCEDURES DELINEATED IN THIS APPENDIX. ANY EXCEPTIONS TO THE BASIC PROCEDURES ARE SPECIFIED IN THIS APPENDIX.

B. DIMENSIONS, CUBE AND WEIGHT OF A SKIDDED UNIT WILL VARY SLIGHTLY DEPENDING UPON THE ACTUAL DIMENSIONS OF THE BOXES AND THE WEIGHT OF THE SPECIFIC ITEM BEING UNITIZED.

C. THE FOLLOWING DARCOM DRAWINGS ARE APPLICABLE FOR OUTLOADING AND STORAGE OF THE ITEMS COVERED BY THIS APPENDIX.

CARLOADING ----- DRAWING 19-48-4123-5PA1003  
 TRUCKLOADING ----- DRAWING 19-48-4124-11PA1004  
 STORAGE ----- DRAWING 19-48-4125-1-2-14PA1003

D. FOR METHOD OF SECURING A STRAP CUTTER TO THE SKIDDED UNIT, SEE DARCOM DRAWING 19-48-4127-20P1000.

E. IF ITEMS COVERED HEREIN ARE UNITIZED PRIOR TO ISSUANCE OF THIS APPENDIX, THE BOXES NEED NOT BE REUNITIZED SOLELY TO CONFORM TO THIS APPENDIX.

F. THE UNITIZATION PROCEDURES DEPICTED HEREIN MAY ALSO BE USED FOR UNITIZING MINES WHEN IDENTIFIED BY DIFFERENT NATIONAL STOCK NUMBERS (NSN) THAN WHAT IS SHOWN ON THE TITLE PAGE, PROVIDED THE BOX PACK DOES NOT VARY FROM WHAT IS DELINEATED HEREIN. THE EXPLOSIVE CLASSIFICATION OF OTHER ITEMS MAY BE DIFFERENT THAN WHAT IS SHOWN.

G. NOTE: IF MORE COST EFFECTIVE, A TYPE II SKID BASE MAY BE USED IN LIEU OF THE TYPE I SKID BASE DEPICTED HEREIN. HOWEVER, A TYPE II SKID BASE MUST BE CONSTRUCTED IN ACCORDANCE WITH THE APPLICABLE SPECIFICATIONS OF THE BASIC PROCEDURE DRAWING AND ALL SPECIFIED STRAPPING MUST BE APPLIED IN ACCORDANCE WITH THE "UNIT ASSEMBLY ON TYPE II SKID BASE" DETAIL SHOWN ON PAGE 8 OF THE BASIC PROCEDURE DRAWING.

### SKIDDED UNIT

SEE GENERAL NOTE "B" AT RIGHT.

9 BOXES (MINE, ANTIPERSONNEL; 10 PER BOX) ..	93.4 LBS --	840 LBS (APPROX)
DUNNAGE .....	4 LBS	
SKID BASE .....	36 LBS	
TOTAL WEIGHT .....		880 LBS (APPROX)
CUBE .....		25.2 CU FT (APPROX)

### BILL OF MATERIAL

TYPE I SKID BASE, 22-1/2" W X 38-3/4" L .....	1 REQD .....	36 LBS
STEEL STRAPPING, 3/4" .....	51.67 REQD .....	3.69 LBS
SEAL FOR 3/4" STRAPPING .....	4 REQD .....	NIL

VERTICAL PIECE, 2" X 4" X BOX HEIGHT MINUS 3/4" (6 REQD). NAIL TO LONGITUDINAL PIECES W/2-10d NAILS AT EACH END.

TIE PIECE, 1" X 4" X BOX WIDTH (3 REQD). NAIL TO LONGITUDINAL PIECES W/2-6d NAILS AT EACH END AND TO LATERAL PIECES W/2-6d NAILS.

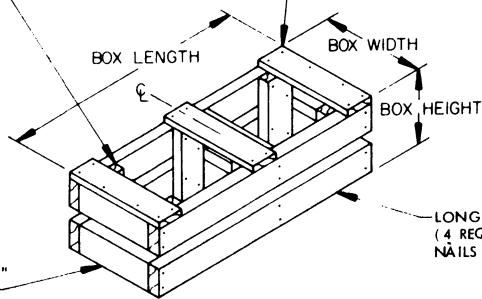

LATERAL PIECE, 2" X 4" X BOX WIDTH MINUS 3" (6 REQD).

LONGITUDINAL PIECE, 2" X 4" X BOX LENGTH (4 REQD). NAIL TO LATERAL PIECES W/2-10d NAILS AT EACH JOINT.

### FILLER ASSEMBLY

(FOR MINUS ONE BOX)