

APPENDIX 86B

UNITIZATION PROCEDURES FOR BOXED AMMUNITION AND COMPONENTS ON SKIDDED BASES

MINE, ANTITANK, HE, PACKED 4 PER WIREBOUND
BOX, UNITIZED 6 BOXES PER TYPE II SKID BASE;
APPROX BOX SIZE $27\frac{15}{16}$ " L X $12\frac{13}{16}$ " W X $14\frac{7}{32}$ " H

SKIDDED UNIT DATA						
ITEMS INCLUDED		HAZARD CLASSIFICATION				WEIGHT (LBS)
NSN	DODIC	DOT CLASS	CG CLASS	QD CLASS	COMP GROUP	
1345- 00-729-4263	K181	A	VII	1.1	D	573

NOTICE: THIS APPENDIX CANNOT STAND ALONE BUT MUST BE
USED IN CONJUNCTION WITH THE BASIC UNITIZATION PROCEDURES
DRAWING 19-48-4138-20PA1000.

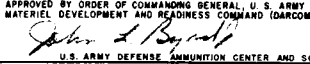
REVISIONS											
			<table border="1" style="width: 100%; border-collapse: collapse;"> <tr> <td style="font-size: small;">DRAFTSMAN</td> <td style="font-size: small;">PROJ ENG</td> </tr> <tr> <td><i>SRS/mbl</i></td> <td><i>VRE/ww</i></td> </tr> <tr> <td style="font-size: small;">CHECKER</td> <td style="font-size: small;">LOG ENGRG OFFICE</td> </tr> <tr> <td><i>ESH/SCG</i></td> <td><i>John Burns</i></td> </tr> </table>	DRAFTSMAN	PROJ ENG	<i>SRS/mbl</i>	<i>VRE/ww</i>	CHECKER	LOG ENGRG OFFICE	<i>ESH/SCG</i>	<i>John Burns</i>
DRAFTSMAN	PROJ ENG										
<i>SRS/mbl</i>	<i>VRE/ww</i>										
CHECKER	LOG ENGRG OFFICE										
<i>ESH/SCG</i>	<i>John Burns</i>										
			<small>APPROVED, U. S. ARMY ARMAMENT MATERIEL READINESS COMMAND</small>  <small>DRSAR - LEP</small>								
			<small>APPROVED BY ORDER OF COMMANDING GENERAL, U. S. ARMY MATERIEL DEVELOPMENT AND READINESS COMMAND (DARCOM)</small>  <small>U. S. ARMY DEFENSE AMMUNITION CENTER AND SCHOOL</small>								
			U. S. ARMY DARCOM DRAWING NOVEMBER 1981								
			<table border="1" style="width: 100%; border-collapse: collapse;"> <tr> <td style="font-size: small;">CLASS</td> <td style="font-size: small;">DIVISION</td> <td style="font-size: small;">DRAWING</td> <td style="font-size: small;">FILE</td> </tr> <tr> <td style="text-align: center;">19</td> <td style="text-align: center;">48</td> <td style="text-align: center;">4138/ 86B</td> <td style="text-align: center;">20PA 1000</td> </tr> </table>	CLASS	DIVISION	DRAWING	FILE	19	48	4138/ 86B	20PA 1000
CLASS	DIVISION	DRAWING	FILE								
19	48	4138/ 86B	20PA 1000								

DO NOT SCALE

TIEDOWN STRAP, 3/4" X .035" OR .031" X 12'-2" LONG STEEL STRAPPING (2 REQD).

TIEDOWN STRAP (SKID), 3/4" X .035" OR .031" X 12'-2" LONG STEEL STRAPPING (2 REQD).

SEAL FOR 3/4" STRAPPING (4 REQD, 1 PER STRAP). CRIMP EACH SEAL WITH TWO PAIR OF NOTCHES.

TYPICAL LOCATION FOR SECUREMENT OF A STRAP CUTTER, WIRE TIE TO STRAP. SEE GENERAL NOTE "F" AT RIGHT.

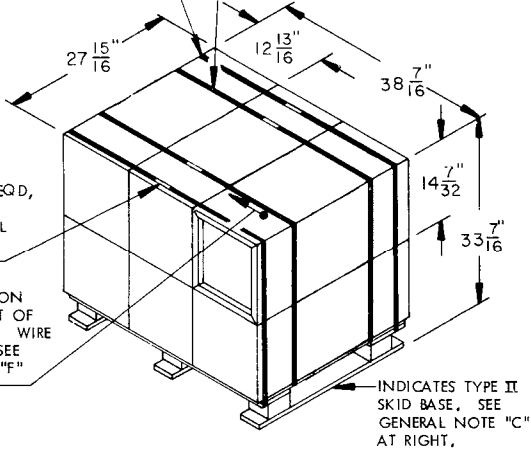

SKIDDED UNIT

SEE GENERAL NOTE "B" AT RIGHT.

6 BOXES (ANTITANK MINE; 4 PER BOX) @ 90 LBS -----	540 LBS (APPROX)
DUNNAGE -----	4 LBS
SKID BASE -----	29 LBS
<hr/>	
TOTAL WEIGHT -----	573 LBS (APPROX)
CUBE -----	20.8 CU FT (APPROX)

GENERAL NOTES

- A. THIS APPENDIX CANNOT STAND ALONE BUT MUST BE USED IN CONJUNCTION WITH THE BASIC UNITIZATION PROCEDURES DRAWING 19-48-4138-20PA1000. TO PRODUCE AN APPROVED UNIT LOAD, ALL PERTINENT PROCEDURES, SPECIFICATIONS AND CRITERIA SET FORTH WITHIN THE BASIC DRAWING WILL APPLY TO THE PROCEDURES DELINEATED IN THIS APPENDIX. ANY EXCEPTIONS TO THE BASIC PROCEDURES ARE SPECIFIED IN THIS APPENDIX.
- B. DIMENSIONS, CUBE AND WEIGHT OF A SKIDDED UNIT WILL VARY SLIGHTLY DEPENDING UPON THE ACTUAL DIMENSIONS OF THE BOXES AND THE WEIGHT OF THE SPECIFIC ITEM BEING UNITIZED.
- C. ONLY A TYPE II SKID BASE WILL BE USED TO ASSEMBLE THIS UNIT. THE "W" DIMENSION OF THE SKID BASE WILL BE 27" AND THE "L" DIMENSION WILL BE 38". NOTE: A TYPE I SKID BASE IS NOT APPROVED FOR UNITIZING THIS ITEM.
- D. WHEN A FILLER ASSEMBLY IS USED IN A UNIT LOAD, THE TIEDOWN STRAPS WILL BE STAPLED TO THE TOP LONGITUDINAL PIECES OF THE ASSEMBLY.
- E. THE FOLLOWING DARCOM DRAWINGS ARE APPLICABLE FOR OUTLOADING AND STORAGE OF THE ITEMS COVERED BY THIS APPENDIX.

CARLOADING -----	DRAWING 19-48-4123-5PA1003
TRUCKLOADING -----	DRAWING 19-48-4124-11PA1004
STORAGE -----	DRAWING 19-48-4125-1-2-14PA1003.
- F. FOR METHOD OF SECURING A STRAP CUTTER TO THE SKIDDED UNIT, SEE DARCOM DRAWING 19-48-4127-20P1000.
- G. IF ITEMS COVERED HEREIN ARE UNITIZED PRIOR TO ISSUANCE OF THIS APPENDIX, THE BOXES NEED NOT BE REUNITIZED SOLELY TO CONFORM TO THIS APPENDIX.
- H. THE UNITIZATION PROCEDURES DEPICTED HEREIN MAY ALSO BE USED FOR UNITIZING ANTITANK MINES WHEN IDENTIFIED BY DIFFERENT NATIONAL STOCK NUMBERS (NSN) THAN WHAT IS SHOWN ON THE TITLE PAGE, PROVIDED THE BOX PACK DOES NOT VARY FROM WHAT IS DELINEATED HEREIN. THE EXPLOSIVE CLASSIFICATION OF OTHER ITEMS MAY BE DIFFERENT THAN WHAT IS SHOWN.

BILL OF MATERIAL

TYPE II SKID BASE, 27" W X 38" L ---	1 REQD -----	29 LBS
STEEL STRAPPING, 3/4" -----	48.67 REQD -----	3.48 LBS
SEAL FOR 3/4" STRAPPING -----	4 REQD -----	NIL

VERTICAL PIECE, 2" X 4" X BOX HEIGHT (4 REQD).

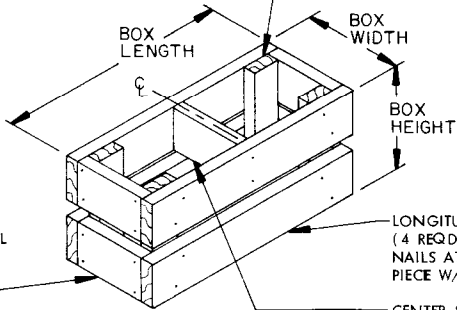

FILLER ASSEMBLY

(SEE GENERAL NOTE "D" AT RIGHT)