

# APPENDIX 13

## UNITIZATION PROCEDURES FOR BOXED AMMUNITION AND COMPONENTS ON SKIDDED BASES

CARTRIDGE, 90MM, PACKED 2 PER WOODEN BOX,  
UNITIZED 16 BOXES PER TYPE I SKID BASE;  
APPROX BOX SIZE 39" L X 12 $\frac{7}{8}$ " W X 8 $\frac{7}{8}$ " H

SKIDDED UNIT DATA						
ITEMS INCLUDED		HAZARD CLASSIFICATION				WEIGHT
NSN	DODIC	DOT CLASS	CG CLASS	QD CLASS	COMP GROUP	(LBS)
1315- 00-028-4431	C262	B	II-B	(08)1.2	C	1,827
00-301-1080	C262	B	II-B	(08)1.2	C	1,827

**NOTICE:** THIS APPENDIX CANNOT STAND ALONE BUT MUST  
BE USED IN CONJUNCTION WITH THE BASIC UNITIZATION  
PROCEDURES DRAWING 19-48-4138-20PA1000.

REVISIONS				DRAFTER	PROJ ENG
				<i>GRS/mek</i>	<i>wef/mw</i>
				<i>RSH/GRS</i>	<i>John Synt</i>
APPROVED, U. S. ARMY ARMAMENT MATERIAL READINESS COMMAND					
				<i>D. Benton</i>	<i>Daniel J. Feltner</i>
APPROVED BY ORDER OF COMMANDING GENERAL, U. S. ARMY MATERIEL DEVELOPMENT AND READINESS COMMAND (DARCOM)					
<i>John Z. Bryant</i>					
U. S. ARMY DEFENSE AMMUNITION CENTER AND SCHOOL					
U. S. ARMY DARCOM DRAWING					
NOVEMBER 1980					
CLASS	DIVISION	DRAWING	FILE		
19	48	4138/13	20PA 1000		

**DO NOT SCALE**

**GENERAL NOTES**

- A. THIS APPENDIX CANNOT STAND ALONE BUT MUST BE USED IN CONJUNCTION WITH THE BASIC UNITIZATION PROCEDURES DRAWING 19-48-4138-20PA1000. TO PRODUCE AN APPROVED UNIT LOAD, ALL PERTINENT PROCEDURES, SPECIFICATIONS AND CRITERIA SET FORTH WITHIN THE BASIC DRAWING WILL APPLY TO THE PROCEDURES DELINEATED IN THIS APPENDIX. ANY EXCEPTIONS TO THE BASIC PROCEDURES ARE SPECIFIED IN THIS APPENDIX.
- B. DIMENSIONS, CUBE AND WEIGHT OF A SKIDDED UNIT WILL VARY SLIGHTLY DEPENDING UPON THE ACTUAL DIMENSIONS OF THE BOXES AND THE WEIGHT OF THE SPECIFIC ITEM BEING UNITIZED.
- C. THE FOLLOWING DARCOM DRAWINGS ARE APPLICABLE FOR OUTLOADING AND STORAGE OF THE ITEMS COVERED BY THIS APPENDIX.
 

CARLOADING -----	DRAWING 19-48-4123-5PA1003
TRUCKLOADING -----	DRAWING 19-48-4124-11PA1004
STORAGE -----	DRAWING 19-48-4123-1-2-14PA1003
- D. FOR METHOD OF SECURING A STRAP CUTTER TO THE SKIDDED UNIT, SEE DARCOM DRAWING 19-48-4127-20P1000.
- E. IF ITEMS COVERED HEREIN ARE UNITIZED PRIOR TO ISSUANCE OF THIS APPENDIX, THE BOXES NEED NOT BE REUNITIZED SOLELY TO CONFORM TO THIS APPENDIX.
- F. THE UNITIZATION PROCEDURES DEPICTED HEREIN MAY ALSO BE USED FOR UNITIZING 90MM CARTRIDGES WHEN IDENTIFIED BY DIFFERENT NATIONAL STOCK NUMBERS (NSN) THAN WHAT IS SHOWN ON THE TITLE PAGE, PROVIDED THE BOX PACK DOES NOT VARY FROM WHAT IS DELINEATED HEREIN. THE EXPLOSIVE CLASSIFICATION OF OTHER ITEMS MAY BE DIFFERENT THAN WHAT IS SHOWN.
- G. NOTE: A TYPE II SKID BASE IS NOT APPROVED FOR USE IN UNITIZING THESE ITEMS. SEE GENERAL NOTE "B" ON PAGE 2 OF THE BASIC PROCEDURES DRAWING 19-48-4138-20PA1000.

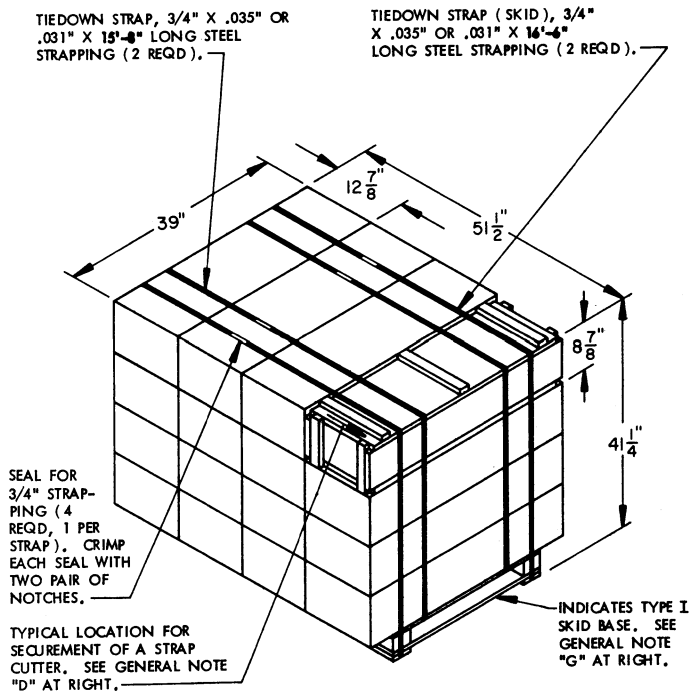

**SKIDDED UNIT**

SEE GENERAL NOTE "B" AT RIGHT.

16 BOXES (90MM CARTRIDGE; 2 PER BOX) @ 111 LBS ----- 1,776 LBS (APPROX)  
 DUNNAGE ----- 5 LBS  
 SKID BASE ----- 46 LBS

TOTAL WEIGHT ----- 1,827 LBS (APPROX)  
 CUBE ----- 47.9 CU FT (APPROX)

**BILL OF MATERIAL**

TYPE I SKID BASE, 29-1/2" W X 50-1/2" L	1 REQD	46 LBS
STEEL STRAPPING, 3/4"	44.33 REQD	4.60 LBS
SEAL FOR 3/4" STRAPPING	4 REQD	NIL

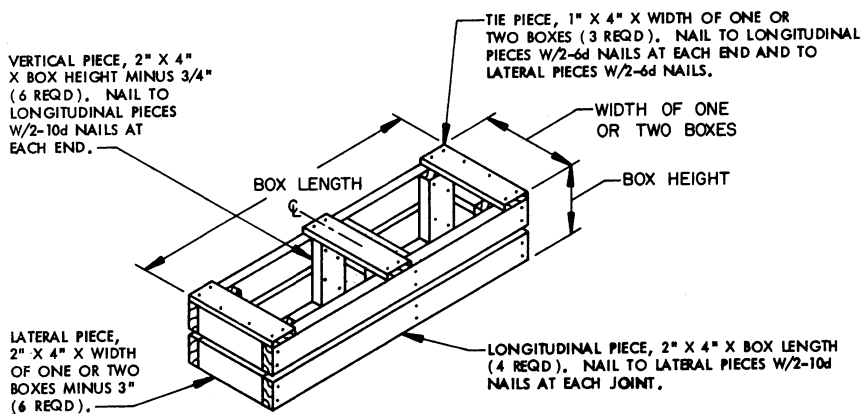

**FILLER ASSEMBLY**

(FOR MINUS ONE OR TWO BOXES)