

TIEDOWN STRAP, 3/4" X .035" OR .031" X 14'-3" LONG STEEL STRAPPING (2 REQD).

TIEDOWN STRAP (SKID), 3/4" X .035" OR .031" X 15'-1" LONG STEEL STRAPPING (2 REQD).

SEAL FOR 3/4" STRAPPING (4 REQD, 1 PER STRAP). CRIMP EACH SEAL WITH TWO PAIR OF NOTCHES.

TYPICAL LOCATION FOR SECUREMENT OF A STRAP CUTTER. SEE GENERAL NOTE "D" AT RIGHT.

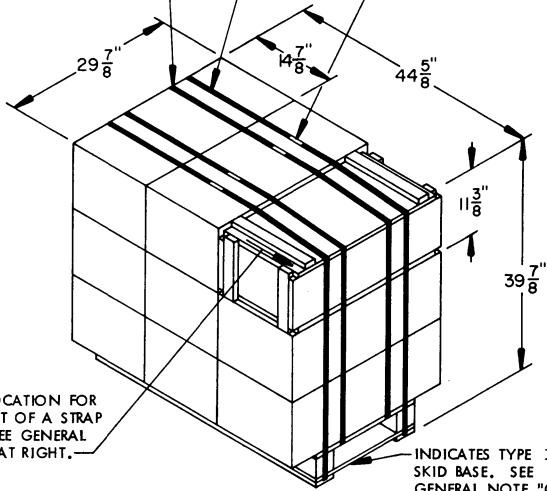

INDICATES TYPE I SKID BASE. SEE GENERAL NOTE "G" AT RIGHT.

SKIDDED UNIT

SEE GENERAL NOTE "B" AT RIGHT.

9 BOXES (POWDER IN WOODEN BOX) @ 199 LBS	-----	1,791 LBS (APPROX)
DUNNAGE	-----	5 LBS
SKID BASE	-----	33 LBS
TOTAL WEIGHT	-----	1,829 LBS (APPROX)
CUBE	-----	30.8 CU FT (APPROX)

GENERAL NOTES

- A. THIS APPENDIX CANNOT STAND ALONE BUT MUST BE USED IN CONJUNCTION WITH THE BASIC UNITIZATION PROCEDURES DRAWING 19-48-4138-20PA1000. TO PRODUCE AN APPROVED UNIT LOAD, ALL PERTINENT PROCEDURES, SPECIFICATIONS AND CRITERIA SET FORTH WITHIN THE BASIC DRAWING WILL APPLY TO THE PROCEDURES DELINEATED IN THIS APPENDIX. ANY EXCEPTIONS TO THE BASIC PROCEDURES ARE SPECIFIED IN THIS APPENDIX.
- B. DIMENSIONS, CUBE AND WEIGHT OF A SKIDDED UNIT WILL VARY SLIGHTLY DEPENDING UPON THE ACTUAL DIMENSIONS OF THE BOXES AND THE WEIGHT OF THE SPECIFIC ITEM BEING UNITIZED.
- C. THE FOLLOWING DARCOM DRAWINGS ARE APPLICABLE FOR OUTLOADING AND STORAGE OF THE ITEMS COVERED BY THIS APPENDIX.

CARLOADING	-----	DRAWING 19-48-4123-5PA1003
TRUCKLOADING	-----	DRAWING 19-48-4124-11PA1004
STORAGE	-----	DRAWING 19-48-4125-1-2-14PA1003
- D. FOR METHOD OF SECURING A STRAP CUTTER TO THE SKIDDED UNIT, SEE DARCOM DRAWING 19-48-4127-20P1000.
- E. IF ITEMS COVERED HEREIN ARE UNITIZED PRIOR TO ISSUANCE OF THIS APPENDIX, THE BOXES NEED NOT BE REUNITIZED SOLELY TO CONFORM TO THIS APPENDIX.
- F. THE UNITIZATION PROCEDURES DEPICTED HEREIN MAY ALSO BE USED FOR UNITIZING POWDER WHEN IDENTIFIED BY DIFFERENT NATIONAL STOCK NUMBERS (NSN) THAN WHAT IS SHOWN ON THE TITLE PAGE, PROVIDED THE BOX PACK DOES NOT VARY FROM WHAT IS DELINEATED HEREIN. THE EXPLOSIVE CLASSIFICATION OF OTHER ITEMS MAY BE DIFFERENT THAN WHAT IS SHOWN.
- G. NOTE: IF MORE COST EFFECTIVE, A TYPE II SKID BASE MAY BE USED IN LIEU OF THE TYPE I SKID BASE DEPICTED HEREIN. HOWEVER, A TYPE II SKID BASE MUST BE CONSTRUCTED IN ACCORDANCE WITH THE APPLICABLE SPECIFICATIONS OF THE BASIC PROCEDURE DRAWING AND ALL SPECIFIED STRAPPING MUST BE APPLIED IN ACCORDANCE WITH THE "UNIT ASSEMBLY ON TYPE II SKID BASE" DETAIL SHOWN ON PAGE 8 OF THE BASIC PROCEDURE DRAWING.

BILL OF MATERIAL

TYPE I SKID BASE, 20-3/8" W X 44" L	-	1 REQD	--	33 LBS
STEEL STRAPPING, 3/4"	-----	58.67' REQD	--	4.19 LBS
SEAL FOR 3/4" STRAPPING	-----	4 REQD	--	NIL

TIE PIECE, 1" X 4" X BOX WIDTH (3 REQD).
NAIL TO LONGITUDINAL PIECES W/2-6d
NAILS AT EACH END AND TO THE LATERAL
PIECE W/1-6d NAIL.

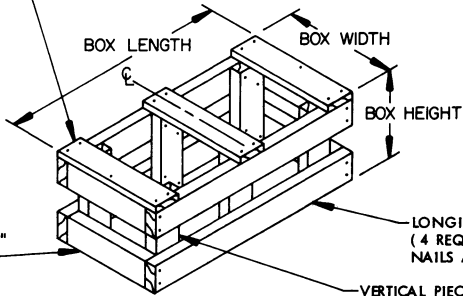

LATERAL PIECE, 2" X 4" X BOX WIDTH MINUS 3" (4 REQD).

LONGITUDINAL PIECE, 2" X 4" X BOX LENGTH (4 REQD). NAIL TO LATERAL PIECES W/2-10d NAILS AT EACH END.

VERTICAL PIECE, 2" X 4" X BOX HEIGHT MINUS 3/4" (6 REQD). NAIL TO LONGITUDINAL PIECES W/2-10d NAILS AT EACH END.

FILLER ASSEMBLY

(FOR MINUS ONE BOX)