

APPENDIX 115

UNITIZATION PROCEDURES FOR BOXED AMMUNITION AND COMPONENTS ON SKIDDED BASES

CHARGE, DEMOLITION, PACKED 40-FT OR 60-FT
PER WOODEN BOX, UNITIZED 8 BOXES PER TYPE II
SKID BASE; APPROX BOX SIZE 31" L X 31" W X 4" H

SKIDDED UNIT DATA						
ITEMS INCLUDED		HAZARD CLASSIFICATION ^①				WEIGHT
NSN	DOD IC	DOT CLASS	CG CLASS	QD CLASS	COMP GROUP	(LBS)
1375- 00-909-4227	M029	A	IX - B	1.1	D	425
01-027-6251	M029	A	IX - B	1.1	D	425

NOTICE: THIS APPENDIX CANNOT STAND ALONE BUT MUST BE USED IN CONJUNCTION WITH THE BASIC UNITIZATION PROCEDURES DRAWING 19-48-4138-20PA1000.

① HAZARD CLASSIFICATION DATA CONTAINED IN THE ABOVE CHART IS FOR GUIDANCE AND INFORMATIONAL PURPOSES ONLY. VERIFICATION OF THE SPECIFIED DATA SHOULD BE MADE BY CONSULTING THE MOST RECENT JOINT HAZARD CLASSIFICATION SYSTEM LISTING OR OTHER APPROVED LISTING(S).

DO NOT SCALE

REVISIONS																															
			<table border="1" style="width: 100%; border-collapse: collapse;"> <tr> <td style="font-size: small;">DRAFTSMAN</td> <td style="font-size: small;">PROJ ENG</td> </tr> <tr> <td style="font-size: small;">CHECKER</td> <td style="font-size: small;">LWS ENGINE OFFICE</td> </tr> <tr> <td colspan="2" style="font-size: x-small;">APPROVED, U. S. ARMY ARMAMENT, MUNITIONS AND CHEMICAL COMMAND</td> </tr> <tr> <td style="text-align: center;"><i>[Signature]</i></td> <td style="text-align: center;"><i>[Signature]</i></td> </tr> <tr> <td style="font-size: x-small;">DDESC - LEP</td> <td style="font-size: x-small;">DRSAC - TMO</td> </tr> <tr> <td colspan="2" style="font-size: x-small;">APPROVED BY ORDER OF COMMANDING GENERAL, U. S. ARMY MATERIAL DEVELOPMENT AND READINESS COMMAND (MARCOR)</td> </tr> <tr> <td colspan="2" style="text-align: center;"><i>[Signature]</i></td> </tr> <tr> <td colspan="2" style="font-size: x-small;">U. S. ARMY DEFENSE AMMUNITION CENTER AND SCHOOL</td> </tr> <tr> <td colspan="2" style="text-align: center;">U. S. ARMY DARCOM DRAWING</td> </tr> <tr> <td colspan="2" style="text-align: center;">NOVEMBER 1983</td> </tr> <tr> <td style="font-size: x-small;">CLASS</td> <td style="font-size: x-small;">DIVISION</td> <td style="font-size: x-small;">DRAWING</td> <td style="font-size: x-small;">FILE</td> </tr> <tr> <td style="text-align: center;">19</td> <td style="text-align: center;">48</td> <td style="text-align: center;">4138/ 115</td> <td style="text-align: center;">20PA 1000</td> </tr> </table>	DRAFTSMAN	PROJ ENG	CHECKER	LWS ENGINE OFFICE	APPROVED, U. S. ARMY ARMAMENT, MUNITIONS AND CHEMICAL COMMAND		<i>[Signature]</i>	<i>[Signature]</i>	DDESC - LEP	DRSAC - TMO	APPROVED BY ORDER OF COMMANDING GENERAL, U. S. ARMY MATERIAL DEVELOPMENT AND READINESS COMMAND (MARCOR)		<i>[Signature]</i>		U. S. ARMY DEFENSE AMMUNITION CENTER AND SCHOOL		U. S. ARMY DARCOM DRAWING		NOVEMBER 1983		CLASS	DIVISION	DRAWING	FILE	19	48	4138/ 115	20PA 1000
DRAFTSMAN	PROJ ENG																														
CHECKER	LWS ENGINE OFFICE																														
APPROVED, U. S. ARMY ARMAMENT, MUNITIONS AND CHEMICAL COMMAND																															
<i>[Signature]</i>	<i>[Signature]</i>																														
DDESC - LEP	DRSAC - TMO																														
APPROVED BY ORDER OF COMMANDING GENERAL, U. S. ARMY MATERIAL DEVELOPMENT AND READINESS COMMAND (MARCOR)																															
<i>[Signature]</i>																															
U. S. ARMY DEFENSE AMMUNITION CENTER AND SCHOOL																															
U. S. ARMY DARCOM DRAWING																															
NOVEMBER 1983																															
CLASS	DIVISION	DRAWING	FILE																												
19	48	4138/ 115	20PA 1000																												

GENERAL NOTES

- A. THIS APPENDIX CANNOT STAND ALONE BUT MUST BE USED IN CONJUNCTION WITH THE BASIC UNITIZATION PROCEDURES DRAWING 19-48-4138-20PA1000. TO PRODUCE AN APPROVED UNIT LOAD, ALL PERTINENT PROCEDURES, SPECIFICATIONS AND CRITERIA SET FORTH WITHIN THE BASIC DRAWING WILL APPLY TO THE PROCEDURES DELINEATED IN THIS APPENDIX. ANY EXCEPTIONS TO THE BASIC PROCEDURES ARE SPECIFIED IN THIS APPENDIX.
- B. DIMENSIONS, CUBE AND WEIGHT OF A SKIDDED UNIT WILL VARY SLIGHTLY DEPENDING UPON THE ACTUAL DIMENSIONS OF THE BOXES AND THE WEIGHT OF THE SPECIFIC ITEM BEING UNITIZED.
- C. ONLY A TYPE II SKID BASE WILL BE USED TO ASSEMBLE THIS UNIT. THE "W" DIMENSION OF THE SKID BASE WILL BE 24" AND THE "L" DIMENSION WILL BE 30". NOTE: A TYPE I SKID BASE IS NOT APPROVED FOR USE IN UNITIZING THIS ITEM.
- D. IT WILL NOT BE NECESSARY TO EVER USE FILLER ASSEMBLIES FOR THE UNIT LOAD COVERED BY THIS APPENDIX DRAWING.
- E. THE FOLLOWING DARCOM DRAWINGS ARE APPLICABLE FOR OUT-LOADING AND STORAGE OF THE ITEMS COVERED BY THIS APPENDIX.
 CARLOADING----- DRAWING 19-48-4123-5PA1003
 TRUCKLOADING ---- DRAWING 19-48-4124-11PA1004
 STORAGE----- DRAWING 19-48-4125-1-2-3-4-14-22PA1003
- F. FOR METHOD OF SECURING A STRAP CUTTER TO THE SKIDDED UNIT, SEE DARCOM DRAWING 19-48-4127-20P1000.
- G. IF ITEMS COVERED HEREIN ARE UNITIZED PRIOR TO ISSUANCE OF THIS APPENDIX, THE BOXES NEED NOT BE REUNITIZED SOLELY TO CONFORM TO THIS APPENDIX.
- H. THE UNITIZATION PROCEDURES DEPICTED HEREIN MAY ALSO BE USED FOR UNITIZING DEMOLITION CHARGE WHEN IDENTIFIED BY DIFFERENT NATIONAL STOCK NUMBERS (NSN) THAN WHAT IS SHOWN ON THE TITLE PAGE, PROVIDED THE BOX PACK DOES NOT VARY FROM WHAT IS DELINEATED HEREIN. THE EXPLOSIVE CLASSIFICATION OF OTHER ITEMS MAY BE DIFFERENT THAN WHAT IS SHOWN.

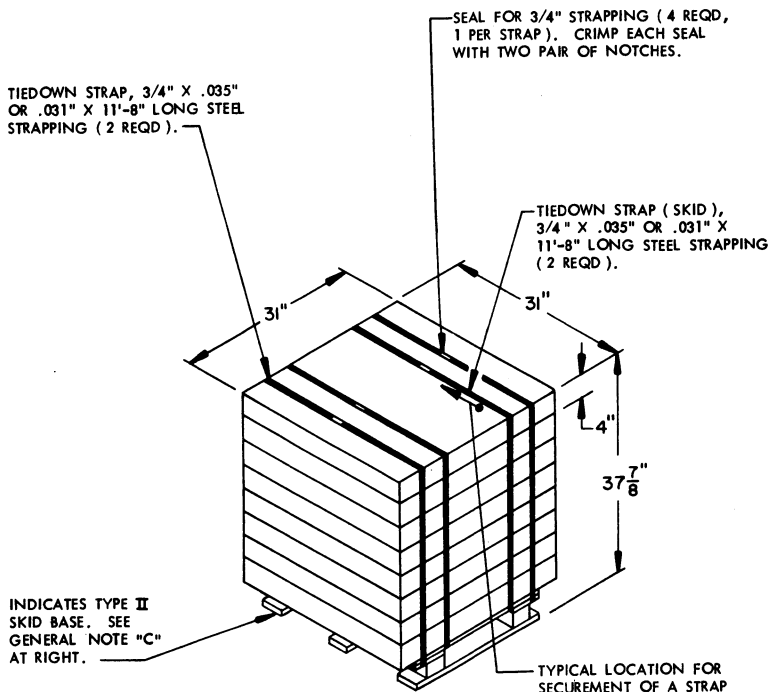

SKIDDED UNIT

SEE GENERAL NOTE "B" AT RIGHT.

8 BOXES (DEMOLITION CHARGE 60' PER BOX) @ 50 LBS-----	400 LBS (APPROX)
DUNNAGE -----	4 LBS
SKID BASE-----	21 LBS
TOTAL WEIGHT -----	425 LBS (APPROX)
CUBE -----	21.1 CU FT (APPROX)

BILL OF MATERIAL

TYPE II SKID BASE, 24" W X 30" L -----	1 REQD -----	21 LBS
STEEL STRAPPING, 3/4" -----	46.67' REQD -----	3.33 LBS
SEAL FOR 3/4" STRAPPING -----	4 REQD -----	NIL