

APPENDIX II

UNITIZATION PROCEDURES FOR BOXED AMMUNITION AND COMPONENTS ON SKIDDED BASES

CARTRIDGE, 76 MM, PACKED 2 PER WOODEN BOX,
UNITIZED 20 BOXES PER TYPE I SKID BASE;
APPROX BOX SIZE $39\frac{3}{8}$ " L X $11\frac{1}{8}$ " W X $7\frac{1}{4}$ " H

SKIDDED UNIT DATA						
ITEMS INCLUDED		HAZARD CLASSIFICATION				WEIGHT (LBS)
NSN	DODIC	DOT CLASS	CG CLASS	QD CLASS	COMP GROUP	
1315-00-028-4732	C122	A	IV	08) 1.2	E	1,726
028-4734	C122	A	IV	(08) 1.2	E	1,726
* 047-3867	C121	B	II-B	(08) 1.2	C	1,726
* 089-5167	C122	A	IV	(08) 1.2	E	1,726
* 752-8475	C098	B	II-B	(08) 1.2	C	1,846
* 756-2833	C110	A	IV	(08) 1.2	E	1,496

* SEE GENERAL NOTE "B" ON PAGE 2.

NOTICE: THIS APPENDIX CANNOT STAND ALONE BUT MUST BE USED IN CONJUNCTION WITH THE BASIC UNITIZATION PROCEDURES DRAWING 19-48-4138-20PA1000.

DO NOT SCALE

REVISIONS				DRAFTSMAN <i>A.G.C./MWR</i>	PROJ ENG <i>A.G.C./MWR</i>
				CHECKER <i>RSW/ABC</i>	LOG ENGINE OFFICE <i>John Byrd</i>
APPROVED, U. S. ARMY ARMAMENT MATERIEL READINESS COMMAND					
			<i>Lawrence Kuster</i> DARCOM-MAD		
			<i>Donald J. Holt</i> DARCOM-TMD		
APPROVED BY ORDER OF COMMANDING GENERAL, U. S. ARMY MATERIEL DEVELOPMENT AND READINESS COMMAND (DARCOM)					
<i>John T. Byrd</i> U. S. ARMY DEFENSE AMMUNITION CENTER AND SCHOOL					
U. S. ARMY DARCOM DRAWING					
JUNE 1980					
CLASS	DIVISION	DRAWING	FILE		
19	48	4138/11	20PA 1000		

GENERAL NOTES

- A. THIS APPENDIX CANNOT STAND ALONE BUT MUST BE USED IN CONJUNCTION WITH THE BASIC UNITIZATION PROCEDURES DRAWING 19-48-4138-20PA1000. TO PRODUCE AN APPROVED UNIT LOAD, ALL PERTINENT PROCEDURES, SPECIFICATIONS AND CRITERIA SET FORTH WITHIN THE BASIC DRAWING WILL APPLY TO THE PROCEDURES DELINEATED IN THIS APPENDIX. ANY EXCEPTIONS TO THE BASIC PROCEDURES ARE SPECIFIED IN THIS APPENDIX.
- B. DIMENSIONS, CUBE AND WEIGHT OF A SKIDDED UNIT WILL VARY SLIGHTLY DEPENDING UPON THE ACTUAL DIMENSIONS OF THE BOXES AND THE WEIGHT OF THE SPECIFIC ITEM BEING UNITIZED. **NOTE:** IF THE BOX LENGTH IS DIFFERENT THAN SHOWN IN THE UNIT DETAIL, THE "W" DIMENSION OF THE SKID BASE MUST BE ADJUSTED TO SUIT THE BOX BEING UNITIZED.
- C. THE FOLLOWING DARCOM DRAWINGS ARE APPLICABLE FOR OUTLOADING AND STORAGE OF THE ITEMS COVERED BY THIS APPENDIX.

CARLOADING -----	DRAWING 19-48-4123-5PA1003
TRUCKLOADING -----	DRAWING 19-48-4124-11PA1004
STORAGE -----	DRAWING 19-48-4125-1-2-14PA1003
- D. FOR METHOD OF SECURING A STRAP CUTTER TO THE SKIDDED UNIT, SEE DARCOM DRAWING 19-48-4127-20P1000.
- E. IF ITEMS COVERED HEREIN ARE UNITIZED PRIOR TO ISSUANCE OF THIS APPENDIX, THE BOXES NEED NOT BE REUNITIZED SOLELY TO CONFORM TO THIS APPENDIX.
- F. THE UNITIZATION PROCEDURES DEPICTED HEREIN MAY ALSO BE USED FOR UNITIZING 76 MM CARTRIDGES WHEN IDENTIFIED BY DIFFERENT NATIONAL STOCK NUMBERS (NSN) THAN WHAT IS SHOWN ON THE TITLE PAGE, PROVIDED THE BOX PACK DOES NOT VARY FROM WHAT IS DELINEATED HEREIN. THE EXPLOSIVE CLASSIFICATION OF OTHER ITEMS MAY BE DIFFERENT THAN WHAT IS SHOWN.
- G. **NOTE:** A TYPE II SKID BASE IS NOT APPROVED FOR USE IN UNITIZING THESE ITEMS. SEE GENERAL NOTE "B" ON PAGE 2 OF THE BASIC PROCEDURES DRAWING 19-48-4138-20PA1000.

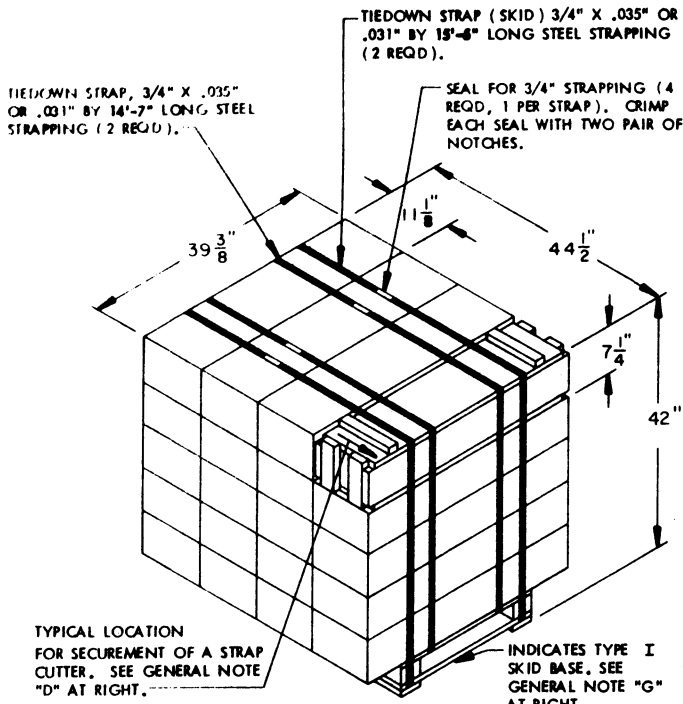

SKIDDED UNIT

SEE GENERAL NOTE "B" AT RIGHT.

20 BOXES (76 MM CARTRIDGE, 2 PER BOX) @ 84 LBS	---	1,680 LBS (APPROX)
DUNNAGE	-----	5 LBS
SKID BASE	-----	41 LBS

TOTAL WEIGHT	-----	1,726 LBS (APPROX)
CUBE	-----	42.6 CU FT (APPROX)

BILL OF MATERIAL

TYPE I SKID BASE, 30" W X 43-1/2" L	--	1 REQD	-----	41 LBS
STEEL STRAPPING, 3/4"	-----	60.00" REQD	-----	4.29 LBS
SEAL FOR 3/4" STRAPPING	-----	4 REQD	-----	NIL

TIE PIECE, 1" X 4" X BOX WIDTH (3 REQD).
NAIL TO LONGITUDINAL PIECES W/2-6d NAILS AT EACH END AND TO THE LATERAL PIECES W/2-6d NAILS.

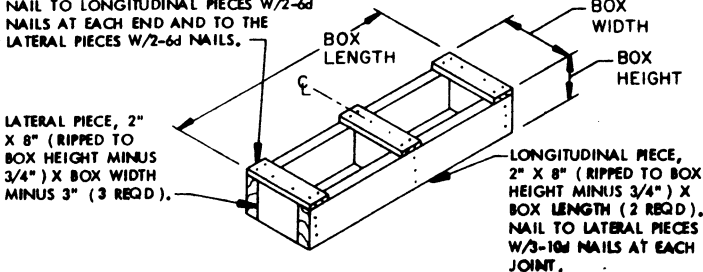

FILLER ASSEMBLY A
(FOR MINUS ONE BOX)

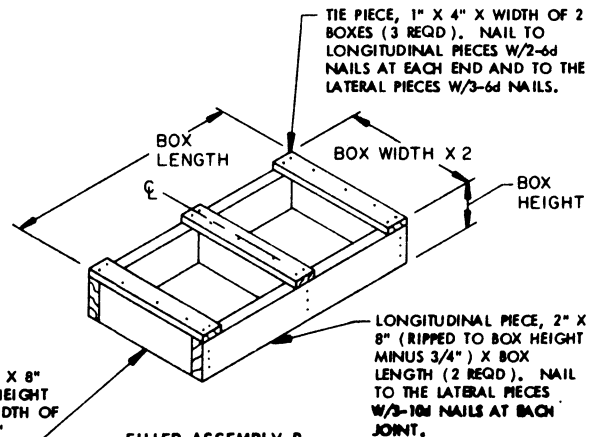

FILLER ASSEMBLY B
(FOR MINUS TWO BOXES)