

APPENDIX 108

UNITIZATION PROCEDURES FOR BOXED AMMUNITION AND COMPONENTS ON SKIDDED BASES

LAUNCHER, GRENADE, SMOKE, PACKED ONE PER
PLYWOOD BOX, UNITIZED 4 BOXES PER TYPE II SKID
BASE; APPROX BOX SIZE 28" L X 28" W X 18" H

SKIDDED UNIT DATA						
ITEMS INCLUDED		HAZARD CLASSIFICATION				WEIGHT
NSN	DOD IC	DOT CLASS	CG CLASS	QD CLASS	COMP GROUP	(LBS)
1040-01-015-0874			INERT			991

NOTICE: THIS APPENDIX CANNOT STAND ALONE BUT MUST BE USED IN CONJUNCTION WITH THE BASIC UNITIZATION PROCEDURES DRAWING 19-48-4138-20PA1000.

REVISIONS				DRAFTSMAN <i>B.L. 100</i>	PROJ ENG <i>FOR WIRE</i>
				CHECKER <i>GEC</i>	LOGGING OFFICE <i>Z. D. W.</i>
				APPROVED, U.S. ARMY AMMUNITION, MUNITIONS AND CHEMICAL COMMAND	
				<i>W. Martin</i>	<i>S. J. Boyd</i>
				APPROVED BY ORDER OF COMMANDING GENERAL, U.S. ARMY AMMUNITION CENTER AND SCHOOL	
				<i>John F. Boyd</i>	
				U.S. ARMY AMC DRAWING	
				JANUARY 1985	
				CLASS	DIVISION
				DRAWING	FILE
				19	48
				4138/ 108	20PA 1000

DO NOT SCALE

TIEDOWN STRAP, 3/4" X .035" OR .031" X 16'-4" LONG STEEL STRAPPING (4 REQD).

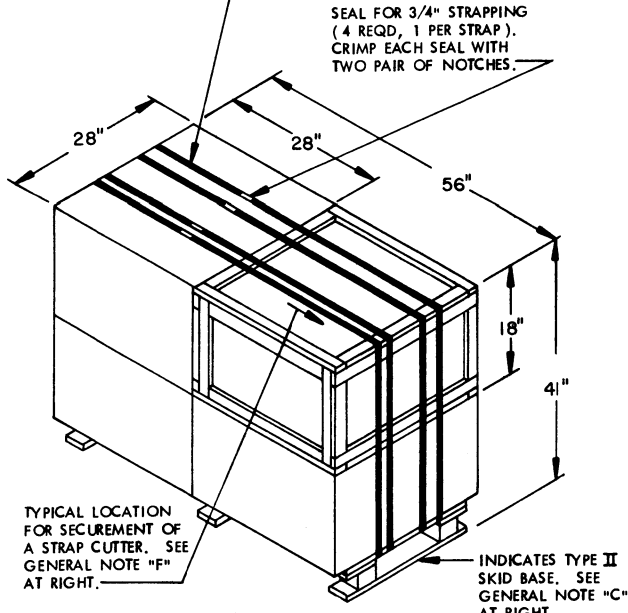

TYPICAL LOCATION FOR SECUREMENT OF A STRAP CUTTER. SEE GENERAL NOTE "F" AT RIGHT.

INDICATES TYPE II SKID BASE. SEE GENERAL NOTE "C" AT RIGHT.

SKIDDED UNIT
SEE GENERAL NOTE "B" AT RIGHT.

4 BOXES OF GRENADE LAUNCHER, (1 PER BOX) @ 240 LBS	----	960 LBS (APPROX)
DUNNAGE	-----	5 LBS
SKID BASE	-----	26 LBS
TOTAL WEIGHT	----	991 LBS (APPROX)
CUBE	-----	37.2 CU FT (APPROX)

GENERAL NOTES

- A. THIS APPENDIX CANNOT STAND ALONE BUT MUST BE USED IN CONJUNCTION WITH THE BASIC UNITIZATION PROCEDURES DRAWING 19-48-4138-20PA1000. TO PRODUCE AN APPROVED UNIT LOAD, ALL PERTINENT PROCEDURES, SPECIFICATIONS AND CRITERIA SET FORTH WITHIN THE BASIC DRAWING WILL APPLY TO THE PROCEDURES DELINEATED IN THIS APPENDIX. ANY EXCEPTIONS TO THE BASIC PROCEDURES ARE SPECIFIED IN THIS APPENDIX.
- B. DIMENSIONS, CUBE AND WEIGHT OF A SKIDDED UNIT WILL VARY SLIGHTLY DEPENDING UPON THE ACTUAL DIMENSIONS OF THE BOXES AND THE WEIGHT OF THE SPECIFIC ITEM BEING UNITIZED.
- C. ONLY A TYPE II SKID BASE WILL BE USED TO ASSEMBLE THIS UNIT. THE "W" DIMENSION OF THE SKID BASE WILL BE 24" AND THE "L" DIMENSION WILL BE 56". NOTE: A TYPE I SKID BASE IS NOT APPROVED FOR USE IN UNITIZING THIS ITEM.
- D. WHEN A FILLER ASSEMBLY IS USED IN A UNIT LOAD, THE TIEDOWN STRAPS WILL BE STAPLED TO THE TOP LONGITUDINAL PIECES OF THE ASSEMBLY.
- E. THE FOLLOWING AMC (DARCOM) DRAWINGS ARE APPLICABLE FOR OUTLOADING AND STORAGE OF THE ITEMS COVERED BY THIS APPENDIX.
 - CARLOADING ----- DRAWING 19-48-4123-5PA1003
 - TRUCKLOADING ----- DRAWING 19-48-4124-11PA1004
 - STORAGE ----- DRAWING 19-48-4128-1-2-3-4-14-22PA1003
- F. FOR METHOD OF SECURING A STRAP CUTTER TO THE PALLET UNIT, SEE DARCOM DRAWING 19-48-4127-20P1000.
- G. IF ITEMS COVERED HEREIN ARE UNITIZED PRIOR TO ISSUANCE OF THIS APPENDIX, THE BOXES NEED NOT BE REUNITIZED SOLELY TO CONFORM TO THIS APPENDIX.
- H. THE UNITIZATION PROCEDURES DEPICTED HEREIN MAY ALSO BE USED FOR UNITIZING GRENADE LAUNCHERS WHEN IDENTIFIED BY DIFFERENT NATIONAL STOCK NUMBERS (NSN) THAN WHAT IS SHOWN ON THE TITLE PAGE, PROVIDED THE BOX PACK DOES NOT VARY FROM WHAT IS DELINEATED HEREIN. THE EXPLOSIVE CLASSIFICATION OF OTHER ITEMS MAY BE DIFFERENT THAN WHAT IS SHOWN.

BILL OF MATERIAL

TYPE II SKID BASE, 24" W X 56" L	---	1	REQD	-----	26 LBS
STEEL STRAPPING, 3/4"	-----	65.33'	REQD	-----	4.67 LBS
SEAL FOR 3/4" STRAPPING	-----	4	REQD	-----	NIL

CENTER SUPPORT PIECE, 2" X 6" X BOX WIDTH MINUS 3" (1 REQD).

VERTICAL PIECE, 2" X 4" X BOX HEIGHT (4 REQD).

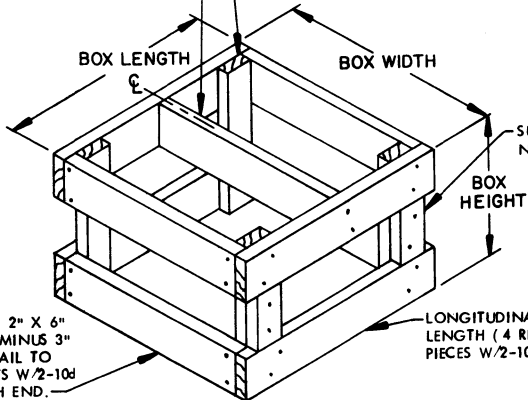

SUPPORT PIECE, 2" X 4" X CUT TO FIT (2 REQD). NAIL TO VERTICAL PIECE W/2-10d NAILS.

LATERAL PIECE, 2" X 6" X BOX WIDTH MINUS 3" (4 REQD). NAIL TO VERTICAL PIECES W/2-10d NAILS AT EACH END.

LONGITUDINAL PIECE, 2" X 6" X BOX LENGTH (4 REQD). NAIL TO VERTICAL PIECES W/2-10d NAILS AT EACH END.

FILLER ASSEMBLY
(FOR MINUS ONE BOX)