

APPENDIX IOI

UNITIZATION PROCEDURES FOR BOXED AMMUNITION AND COMPONENTS ON SKIDDED BASES

FLARE, AIRCRAFT, PACKED 2 PER WOODEN BOX,
UNITIZED 16 BOXES PER TYPE I SKID BASE;
APPROX BOX SIZE $28\frac{5}{8}$ " L X $11\frac{7}{16}$ " W X $6\frac{29}{32}$ " H

SKIDDED UNIT DATA						
ITEMS INCLUDED		HAZARD CLASSIFICATION				WEIGHT (LBS)
NSN	DODIC	DOT CLASS	CG CLASS	QD CLASS	COMP GROUP	
1370-00 028-5931	L388	B	II-C	1.3	G	1,002

NOTICE: THIS APPENDIX CANNOT STAND ALONE BUT MUST BE USED IN CONJUNCTION WITH THE BASIC UNITIZATION PROCEDURES DRAWING 19-48-4138-20PA1000.

REVISIONS				DRAFTSMAN MND/aw	PROJ ENG MND/aw
				CHECKER RSH/GRG	LOG ENGRG OFFICE John Boyd
APPROVED, U. S. ARMY ARMAMENT MATERIAL READINESS COMMAND					
		<i>W. H. Benton</i>		<i>Darrell C. Felty</i>	
		DRSAR - MAB		DRSAR - TMD	
APPROVED BY ORDER OF COMMANDING GENERAL, U. S. ARMY MATERIAL DEVELOPMENT AND READINESS COMMAND (DARCOM)					
<i>John T. Seynold</i>					
U. S. ARMY DEFENSE AMMUNITION CENTER AND SCHOOL					
U. S. ARMY DARCOM DRAWING					
FEBRUARY 1981					
CLASS	DIVISION	DRAWING	FILE		
19	48	4138/101	20PA 1000		

DO NOT SCALE

TIEDOWN STRAP, 3/4" X .035" OR .031"
X 18'-5" LONG STEEL STRAPPING (2 REQD).

TIEDOWN STRAP (SKID),
3/4" X .035" OR .031" X
14'-3" LONG STEEL
STRAPPING (2 REQD).

SEAL FOR 3/4"
STRAPPING (4
REQD), 1 PER
STRAP). CRIMP
EACH SEAL WITH
TWO PAIR OF
NOTCHES.

TYPICAL LOCATION
FOR SECUREMENT
OF A STRAP CUTTER.
SEE
GENERAL NOTE "D"
AT RIGHT.

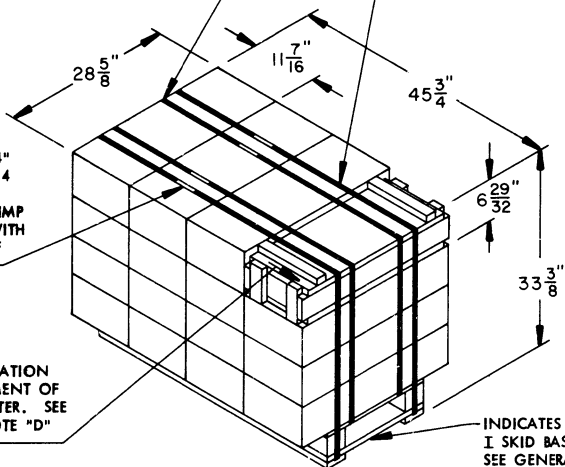

SKIDDED UNIT

SEE GENERAL NOTE "B" AT RIGHT.

16 BOXES (FLARE, AIRCRAFT; 2 PER BOX) @ 60 LBS ----- 960 LBS (APPROX)
DUNNAGE ----- 4 LBS (APPROX)
SKID BASE ----- 38 LBS

TOTAL WEIGHT ----- 1,002 LBS (APPROX)

CUBE ----- 25.3 CU FT (APPROX)

GENERAL NOTES

- A. THIS APPENDIX CANNOT STAND ALONE BUT MUST BE USED IN CONJUNCTION WITH THE BASIC UNITIZATION PROCEDURES DRAWING 19-48-4138-20PA1000. TO PRODUCE AN APPROVED UNIT LOAD, ALL PERTINENT PROCEDURES, SPECIFICATIONS AND CRITERIA SET FORTH WITHIN THE BASIC DRAWING WILL APPLY TO THE PROCEDURES DELINEATED IN THIS APPENDIX. ANY EXCEPTIONS TO THE BASIC PROCEDURES ARE SPECIFIED IN THIS APPENDIX.
- B. DIMENSIONS, CUBE AND WEIGHT OF A SKIDDED UNIT WILL VARY SLIGHTLY DEPENDING UPON THE ACTUAL DIMENSIONS OF THE BOXES AND THE WEIGHT OF THE SPECIFIC ITEM BEING UNITIZED.
- C. THE FOLLOWING DARCOM DRAWINGS ARE APPLICABLE FOR OUTLOADING AND STORAGE OF THE ITEMS COVERED BY THIS APPENDIX.
CARLOADING ----- DRAWING 19-48-4123-5PA1003
TRUCKLOADING ----- DRAWING 19-48-4124-11PA1004
STORAGE ----- DRAWING 19-48-4125-1-2-14PA1003
- D. FOR METHOD OF SECURING A STRAP CUTTER TO THE SKIDDED UNIT, SEE DARCOM DRAWING 19-48-4127-20P1000.
- E. IF ITEMS COVERED HEREIN ARE UNITIZED PRIOR TO ISSUANCE OF THIS APPENDIX, THE BOXES NEED NOT BE REUNITIZED SOLELY TO CONFORM TO THIS APPENDIX.
- F. THE UNITIZATION PROCEDURES DEPICTED HEREIN MAY ALSO BE USED FOR UNITIZING AIRCRAFT FLARES WHEN IDENTIFIED BY DIFFERENT NATIONAL STOCK NUMBERS (NSN) THAN WHAT IS SHOWN ON THE TITLE PAGE, PROVIDED THE BOX PACK DOES NOT VARY FROM WHAT IS DELINEATED HEREIN. THE EXPLOSIVE CLASSIFICATION OF OTHER ITEMS MAY BE DIFFERENT THAN WHAT IS SHOWN.
- G. NOTE: A TYPE II SKID BASE IS NOT APPROVED FOR USE IN UNITIZING THESE ITEMS. SEE GENERAL NOTE "B" ON PAGE 2 OF THE BASIC PROCEDURES DRAWING 19-48-4138-20PA1000.

BILL OF MATERIAL

TYPE I SKID BASE, 19-1/8" W X 44-3/4" L -- 1 REQD -- 38 LBS
STEEL STRAPPING, 3/4" ----- 55.30' REQD -- 3.95 LBS
SEAL FOR 3/4" STRAPPING ----- 4 REQD -- NIL

TIE PIECE, 1" X 4" X BOX WIDTH (3 REQD).
NAIL TO LONGITUDINAL PIECES W/2-6d
NAILS AT EACH END AND TO LATERAL
PIECE W/2-6d NAILS.

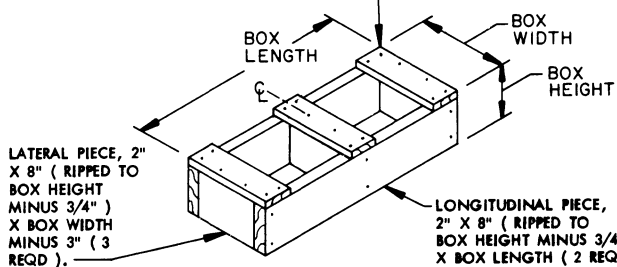

FILLER ASSEMBLY A

(FOR MINUS ONE BOX)

TIE PIECE, 1" X 4" X WIDTH OF TWO BOXES (3 REQD).
NAIL TO LONGITUDINAL PIECES W/2-6d NAILS AT EACH
END AND TO LATERAL PIECE W/3-6d NAILS.

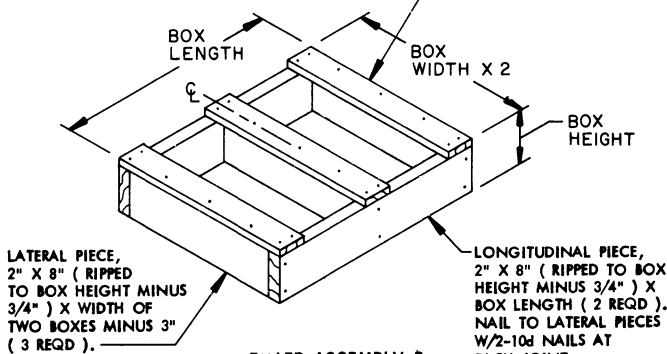

FILLER ASSEMBLY B

(FOR MINUS TWO BOXES)