

APPENDIX 10

UNITIZATION PROCEDURES FOR BOXED AMMUNITION AND COMPONENTS ON SKIDDED BASES

CARTRIDGE, 75 MM, PACKED 2 PER WOODEN
BOX, UNITIZED 20 BOXES PER TYPE I SKID
BASE; APPROX BOX SIZE $34\frac{1}{4}$ " L X $11\frac{1}{4}$ " W X
 $7\frac{1}{4}$ " H

SKIDDED UNIT DATA						
ITEMS INCLUDED		HAZARD CLASSIFICATION				WEIGHT (LBS)
NSN	DODIC	DOT CLASS	CG CLASS	QD CLASS	COMP GROUP	
1315-00-						
* 028-4651	C053	A	IV	1.1	E	1,442
* 028-4654	C051	A	IV	(08)1.2	E	1,662
028-4658	C051	A	IV	(08)1.2	E	1,642
028-4659	C057	A	IV	(08)1.2	E	1,502
028-4661	C054	A	IV	(08)1.2	E	1,602
028-4662	C052	A	IV	1.1	E	1,502
892-4896	C051	A	IV	(08)1.2	E	1,642

* SEE GENERAL NOTE "B" ON PAGE 2.

NOTICE: THIS APPENDIX CANNOT STAND ALONE BUT MUST BE
USED IN CONJUNCTION WITH THE BASIC UNITIZATION PROCEDURES
DRAWING 19-48-4138-20PA1000.

REVISIONS			
			<small>DRAWN BY</small> <i>W.E. MSHA/GC/MND</i> <small>PROJ ENG</small> <small>CHECKED</small> <i>A.H.C.</i> <small>LOG ENGRG OFFICER</small> <small>APPROVED, U. S. ARMY ARMAMENT MATERIEL READINESS COMMAND</small> <i>John L. Bryant Jr.</i> <small>DRSAR-MAD</small> <small>DRSAR-TMD</small> <small>APPROVED BY ORDER OF COMMANDING GENERAL, U. S. ARMY MATERIEL DEVELOPMENT AND READINESS COMMAND (DARCOM)</small> <small>U. S. ARMY DEFENSE AMMUNITION CENTER AND SCHOOL</small> U. S. ARMY DARCOM DRAWING JANUARY 1980 <small>CLASS</small> <small>DIVISION</small> <small>DRAWING</small> <small>FILE</small> 19 48 4138/10 20PA 1000

DO NOT SCALE

TIEDOWN STRAP, 3/4" X .035" OR .031" BY 14'-8" LONG STEEL STRAPPING (2 REQD).

TIEDOWN STRAP (SKID)
3/4" X .035" OR .031" BY 15'-4" LONG STEEL STRAPPING (2 REQD).

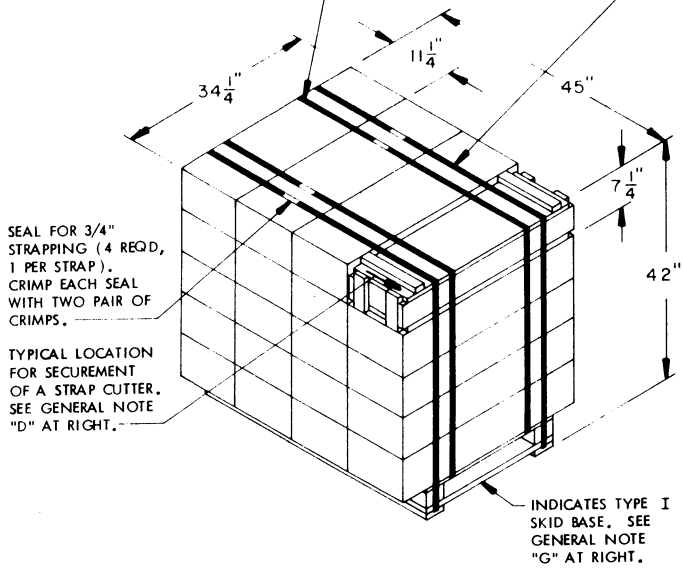

SKIDDED UNIT

SEE GENERAL NOTE "B" AT RIGHT.

20 BOXES (75 MM CARTRIDGE; 2 PER BOX) @ 78 LBS	-----	1,560 LBS (APPROX)
DUNNAGE	-----	5 LBS
SKID BASE	-----	37 LBS
TOTAL WEIGHT	-----	1,602 LBS (APPROX)
CUBE	-----	37.5 CU FT (APPROX)

BILL OF MATERIAL

TYPE I SKID BASE 24-3/4" W X 44" L	----	1 REQD	-----	37 LBS
STEEL STRAPPING, 3/4"	-----	60.33' REQD	-----	4.31 LBS
SEAL FOR 3/4" STRAPPING	-----	4 REQD	-----	NIL

GENERAL NOTES

- A. THIS APPENDIX CANNOT STAND ALONE BUT MUST BE USED IN CONJUNCTION WITH THE BASIC UNITIZATION PROCEDURES DRAWING 19-48-4138-20PA1000. TO PRODUCE AN APPROVED UNIT LOAD, ALL PERTINENT PROCEDURES, SPECIFICATIONS AND CRITERIA SET FORTH WITHIN THE BASIC DRAWING WILL APPLY TO THE PROCEDURES DELINEATED IN THIS APPENDIX. ANY EXCEPTIONS TO THE BASIC PROCEDURES ARE SPECIFIED IN THIS APPENDIX.
- B. DIMENSIONS, CUBE AND WEIGHT OF A SKIDDED UNIT WILL VARY SLIGHTLY DEPENDING UPON THE ACTUAL DIMENSIONS OF THE BOXES AND THE WEIGHT OF THE SPECIFIC ITEM BEING UNITIZED. NOTE: IF THE BOX LENGTH IS DIFFERENT THAN THAT SHOWN IN THE UNIT DETAIL, THE "W" DIMENSION OF THE SKID BASE MUST BE ADJUSTED TO SUIT THE BOX BEING UNITIZED. IF THE BOX WIDTH IS DIFFERENT THAN THAT SHOWN IN THE UNIT DETAIL, THE "L" DIMENSION OF THE SKID BASE MUST BE ADJUSTED TO SUIT THE BOX BEING UNITIZED.
- C. THE FOLLOWING DARCOM DRAWINGS ARE APPLICABLE FOR OUTLOADING AND STORAGE OF THE ITEMS COVERED BY THIS APPENDIX.

CARLOADING -----	DRAWING 19-48-4123-5PA1003
TRUCKLOADING -----	DRAWING 19-48-4124-11PA1004
STORAGE -----	DRAWING 19-48-4125-1-2-14PA1003
- D. FOR METHOD OF SECURING A STRAP CUTTER TO THE SKIDDED UNIT, SEE DARCOM DRAWING 19-48-4127-20P1000.
- E. IF ITEMS COVERED HEREIN ARE UNITIZED PRIOR TO ISSUANCE OF THIS APPENDIX, THE BOXES NEED NOT BE REUNITIZED SOLELY TO CONFORM TO THIS APPENDIX.
- F. THE UNITIZATION PROCEDURES DEPICTED HEREIN MAY ALSO BE USED FOR UNITIZING 75 MM CARTRIDGES WHEN IDENTIFIED BY DIFFERENT NATIONAL STOCK NUMBERS (NSN) THAN WHAT IS SHOWN ON THE TITLE PAGE, PROVIDED THE BOX PACK DOES NOT VARY FROM WHAT IS DELINEATED HEREIN. THE EXPLOSIVE CLASSIFICATION OF OTHER ITEMS MAY BE DIFFERENT THAN WHAT IS SHOWN.
- G. NOTE: A TYPE II SKID BASE IS NOT APPROVED FOR USE IN UNITIZING THESE ITEMS. SEE GENERAL NOTE "B" ON PAGE 2 OF THE BASIC PROCEDURES DRAWING 19-48-4138-20PA1000.

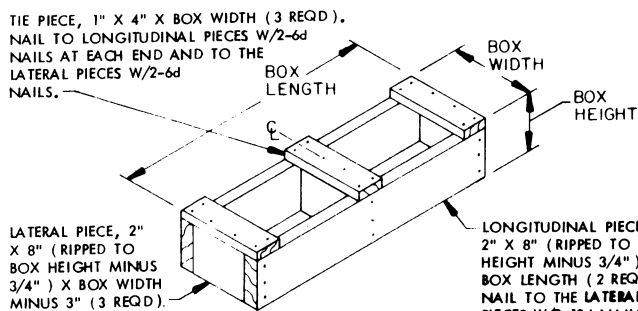

FILLER ASSEMBLY A
(FOR MINUS ONE BOX)

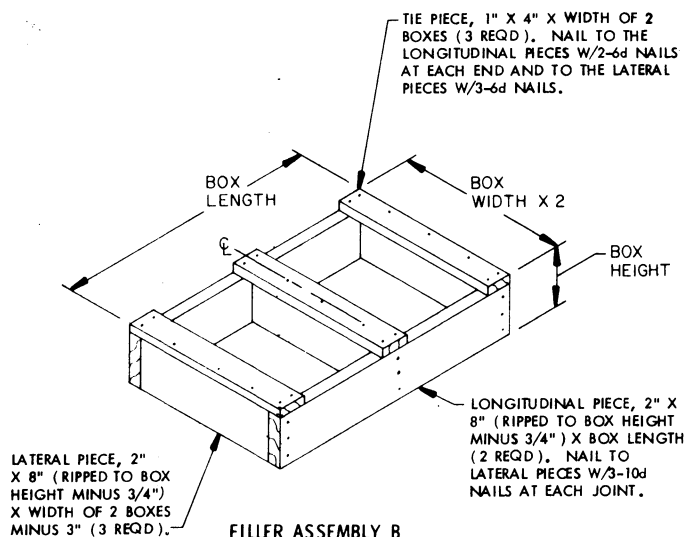

FILLER ASSEMBLY B
(FOR MINUS TWO BOXES)