

STORAGE IN 60' & 80' IGLOO AND 80' STRADLEY MAGAZINES OF 750- POUND BOMB (HIGH EXPLOSIVE) PACKED TWO PER WOODEN PALLET

INDEX

ITEM	PAGE(S)
GENERAL NOTES, AND MATERIAL SPECIFICATIONS-----	3
IGLOO STORAGE PROCEDURES-----	2,3
STRADLEY STORAGE PROCEDURES-----	4,5
DETAILS-----	6-8

DRAFTERMAN <i>TAS</i>	PROJ. ENG. <i>C. S. / WDP</i>	APSA <i>C. S.</i>	SUBMITTED <i>C. S. / WDP, C. S.</i>
CHECKER <i>TAS</i>	ENG. AMMO. CTR. <i>John Boyd</i>		COMMANDING OFFICER, SAVANNA ARMY DEPOT
REVISIONS			EXAMINED AND APPROVED <i>S. J. ...</i>
			AMMUNITION PROCUREMENT & SUPPLY AGENCY
			APPROVED BY ORDER OF COMMANDING GENERAL U. S. ARMY MATERIEL COMMAND
			<i>Paul ...</i>
			U. S. ARMY MATERIEL COMMAND
			MARCH 1970
			CLASS DIVISION DRAWING FILE
			19 48 4094 1-14 PB 1001

DO NOT SCALE

LATERAL INSPECTION AISLE.
SEE GENERAL NOTE "C" ON PAGE 3.

STORAGE AS SHOWN
80' IGLOO

ITEM	QUANTITY
PALLET UNIT	457
BOMB	914
EXPLOSIVE WEIGHT	353,000 LBS (APPROX)

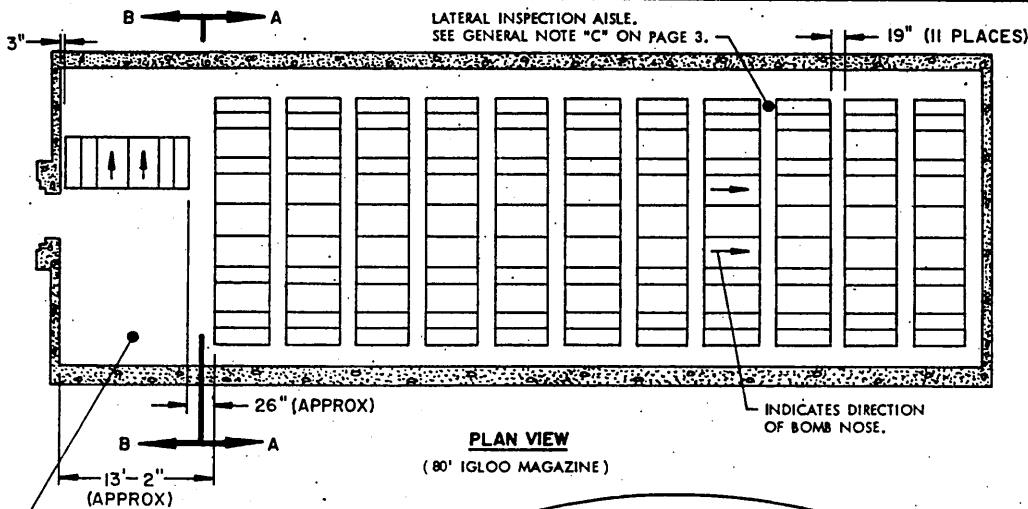

PLAN VIEW
(80' IGLOO MAGAZINE)

SEE GENERAL NOTE "D"
ON PAGE 3.

SEE GENERAL NOTE "E"
ON PAGE 3.

ACCESS
AISLE.

ACCESS
AISLE.

30"
(APPROX)

WEDGE, 2" X 4" X 9'-0"
(4 REQD PER STACK). SEE
"WEDGE DETAIL" ON PAGE
5, AND DETAIL ON PAGE 7
FOR PLACEMENT GUIDANCE.

SECTION A-A
(40 PALLET UNITS PER STACK)

INDICATES DOOR
OPENING.

STACK STABILIZING
ASSEMBLY (1 REQD FOR
EACH UPPER LAYER PALLET
UNIT). SEE DETAIL ON
PAGE 8 AND GENERAL
NOTE "G" ON PAGE 3.

30"

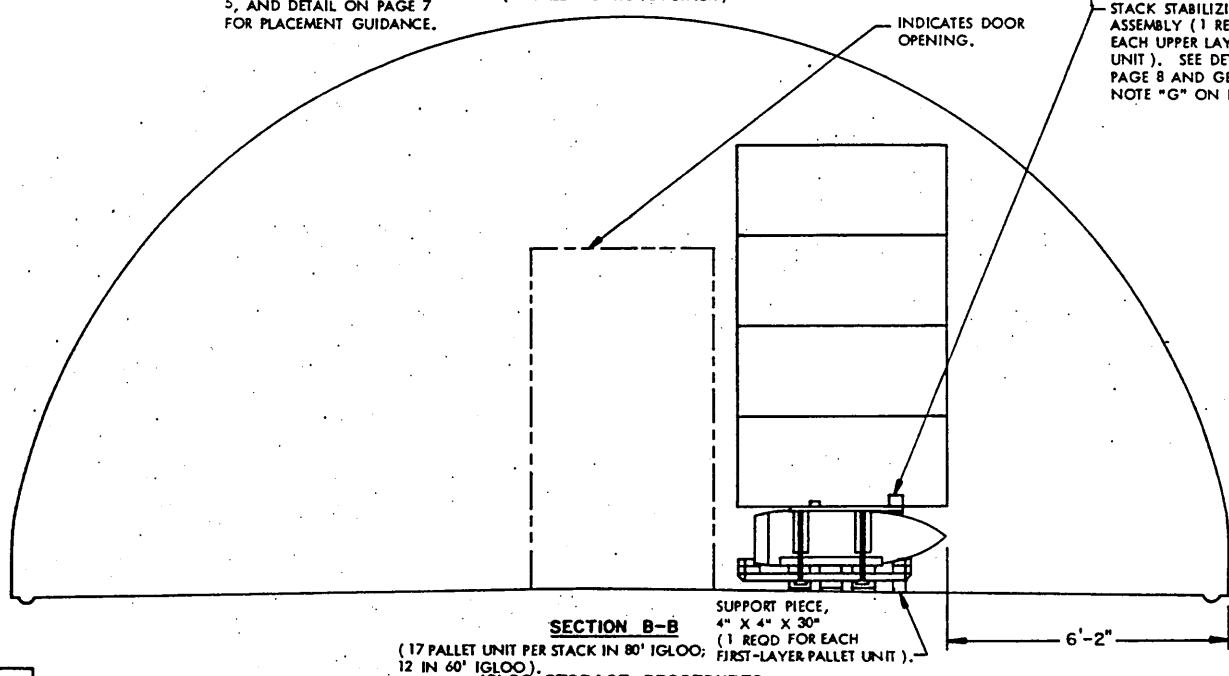

SECTION B-B
(17 PALLET UNIT PER STACK IN 80' IGLOO;
12 IN 60' IGLOO).

SUPPORT PIECE,
4" X 4" X 30"
(1 REQD FOR EACH
FIRST-LAYER PALLET UNIT).

6'-2"

STORAGE AS SHOWN
60' IGL00

ITEM	QUANTITY
PALLET UNIT -----	332
BOMB -----	664
EXPLOSIVE WEIGHT --	256,000 LBS (APPROX)

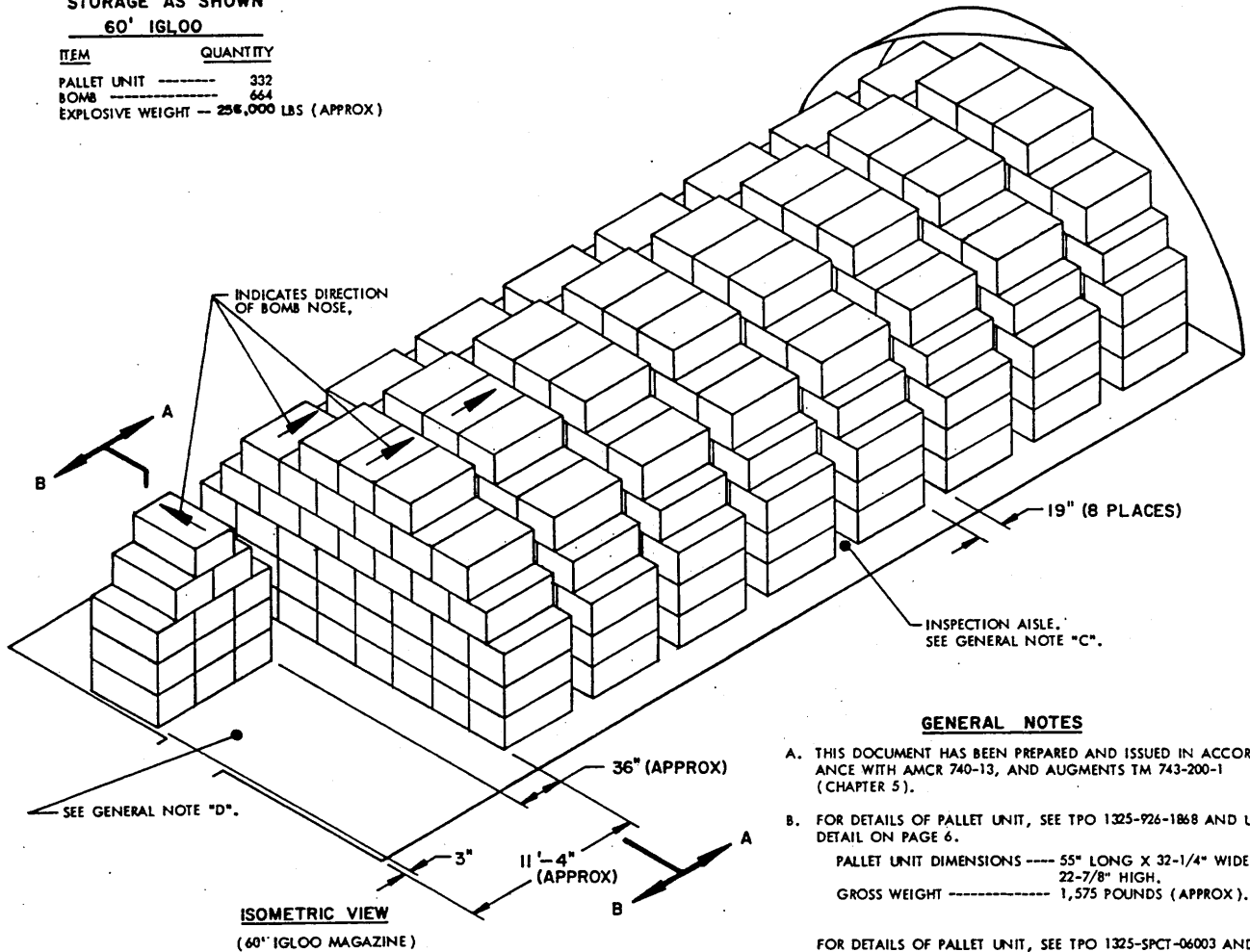

GENERAL NOTES

- A. THIS DOCUMENT HAS BEEN PREPARED AND ISSUED IN ACCORDANCE WITH AMCR 740-13, AND AUGMENTS TM 743-200-1 (CHAPTER 5).
- B. FOR DETAILS OF PALLET UNIT, SEE TPO 1325-926-1868 AND UNIT DETAIL ON PAGE 6.
 PALLET UNIT DIMENSIONS ---- 55" LONG X 32-1/4" WIDE X 22-7/8" HIGH.
 GROSS WEIGHT ----- 1,575 POUNDS (APPROX).
- FOR DETAILS OF PALLET UNIT, SEE TPO 1325-SPCT-06003 AND UNIT DETAIL ON PAGE 6.
 PALLET UNIT DIMENSIONS ---- 51" LONG X 32" WIDE X 23" HIGH.
 GROSS WEIGHT ----- 1,566 POUNDS (APPROX).
- C. AISLE DIMENSIONS SHOWN HEREIN MAY BE ADJUSTED TO SUIT LOCAL CONDITIONS AND/OR AVAILABLE MATERIALS HANDLING EQUIPMENT (MHE). HOWEVER, FOR USE OF THE TPO 1325-926-1868 PALLET, A NINETEEN INCH (19") (MINIMUM) LATERAL INSPECTION AISLE IS REQUIRED; FOR USE OF THE TPO 1325-SPCT-06003 PALLET, A TWENTY-THREE INCH (23") (MINIMUM) LATERAL INSPECTION AISLE IS REQUIRED TO FACILITATE INSPECTION OF BOMBS AT BOTH ENDS.
- D. IF THE AVAILABLE MATERIALS HANDLING EQUIPMENT (MHE) PERMITS, ADDITIONAL PALLET UNITS MAY BE STORED WITHIN THE FRONTAL AREA OF THE MAGAZINES.
- E. STORED PALLET UNITS MUST NOT CONTACT THE WALL OF A MAGAZINE. TO PROVIDE FOR THIS MANDATORY CLEARANCE REQUIREMENT, PALLET UNITS MAY BE ELIMINATED FROM THE DEPICTED STACKING PATTERN AS NECESSARY, OR AISLE DIMENSIONS MAY BE ADJUSTED AS PER GENERAL NOTE "C", ABOVE.
- F. CARE SHOULD BE EXERCISED WHEN STORING, SO THAT THE EXPLOSIVE LIMIT FOR THE MAGAZINE IS NOT EXCEEDED.
- G. STORAGE AS SHOWN DEPICTS USE OF PALLET UNIT SPECIFIED BY TPO 1325-926-1868. THE STORAGE METHODS SHOWN ARE ALSO APPLICABLE TO THE STORAGE OF PALLET UNITS SPECIFIED BY TPO 1325-SPCT-06003. NOTICE: WHEN STORING PALLET UNITS AS SPECIFIED BY TPO 1325-SPCT-06003, THE "STACK STABILIZING ASSEMBLY" METHOD OF DUNNAGING STACKS WILL NOT BE USED. HOWEVER, WEDGES WILL BE REQUIRED AS SPECIFIED HEREIN.
- H. CAUTION: PALLET UNITS WILL NOT BE STACKED MORE THAN THREE (3) HIGH WITHOUT STAGGER-STACKING THE UPPER LAYERS AS SHOWN.

BILL OF MATERIAL (PER 40-UNIT STACK)

LUMBER	LINEAR FEET	BOARD FEET
1" X 2"	54	9
1" X 4"	240	80
3" X 4"	100	100
NAILS		POUNDS
4d (1-1/2")	128	1/2
12d (3-1/4")	128	2-1/4
WEDGES		NO. REQD
2" X 4" X 9'-0"		4

MATERIAL SPECIFICATIONS

LUMBER: SEE TM 743-200-1, DUNNAGE LUMBER; FED SPEC MM-L-751.

NAILS: COMMON, CEMENT COATED OR CHEMICALLY ETCHED, FED SPEC FF-N-105.
 ALT: ANNULAR-RING TYPE NAIL OF SAME SIZE.

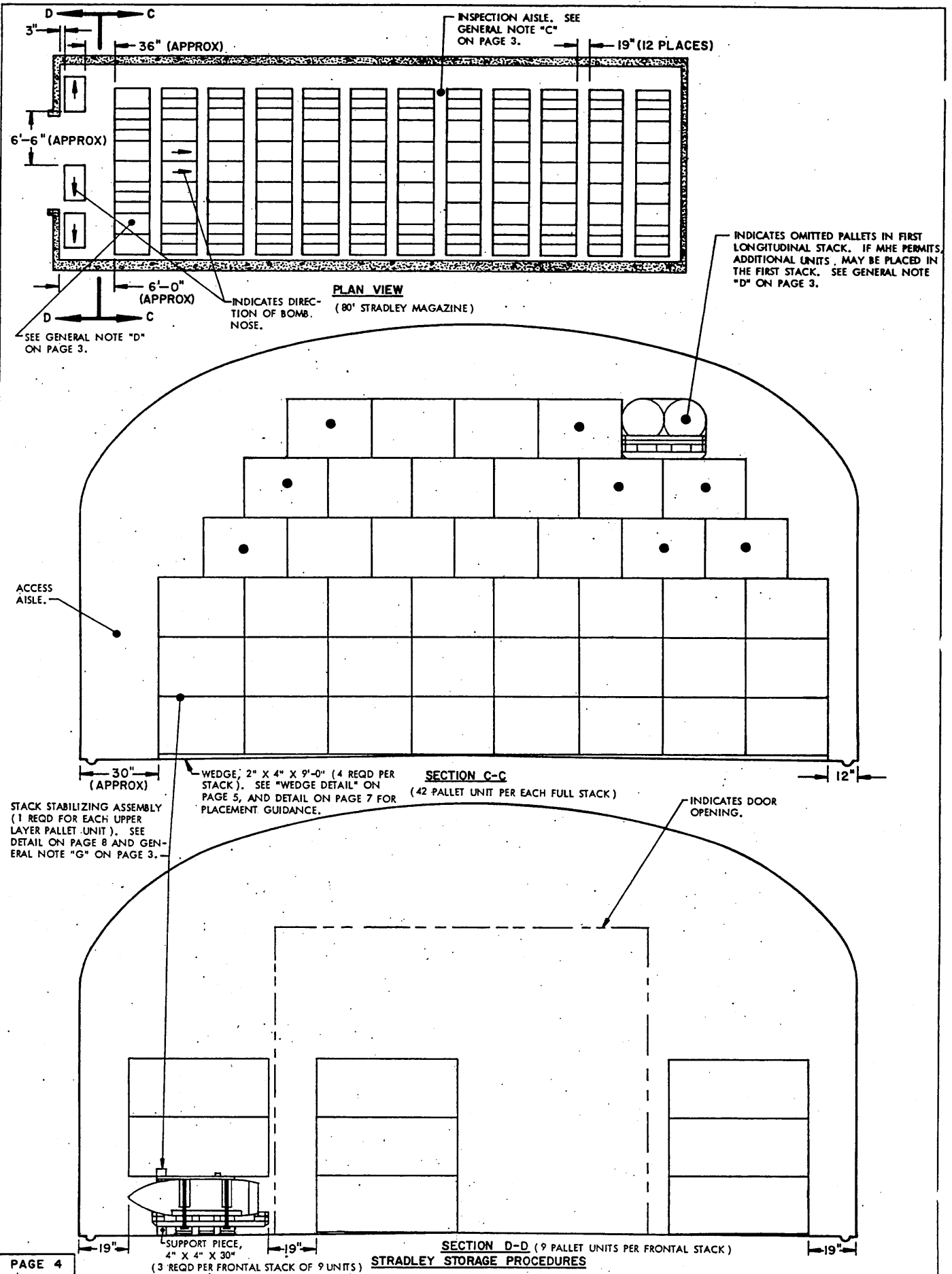

STORAGE AS SHOWN

80' STRADLEY

ITEM	QUANTITY
PALLET UNIT -----	504
BOMB -----	1,008
EXPLOSIVE WEIGHT -----	389,000 LBS (APPROX)

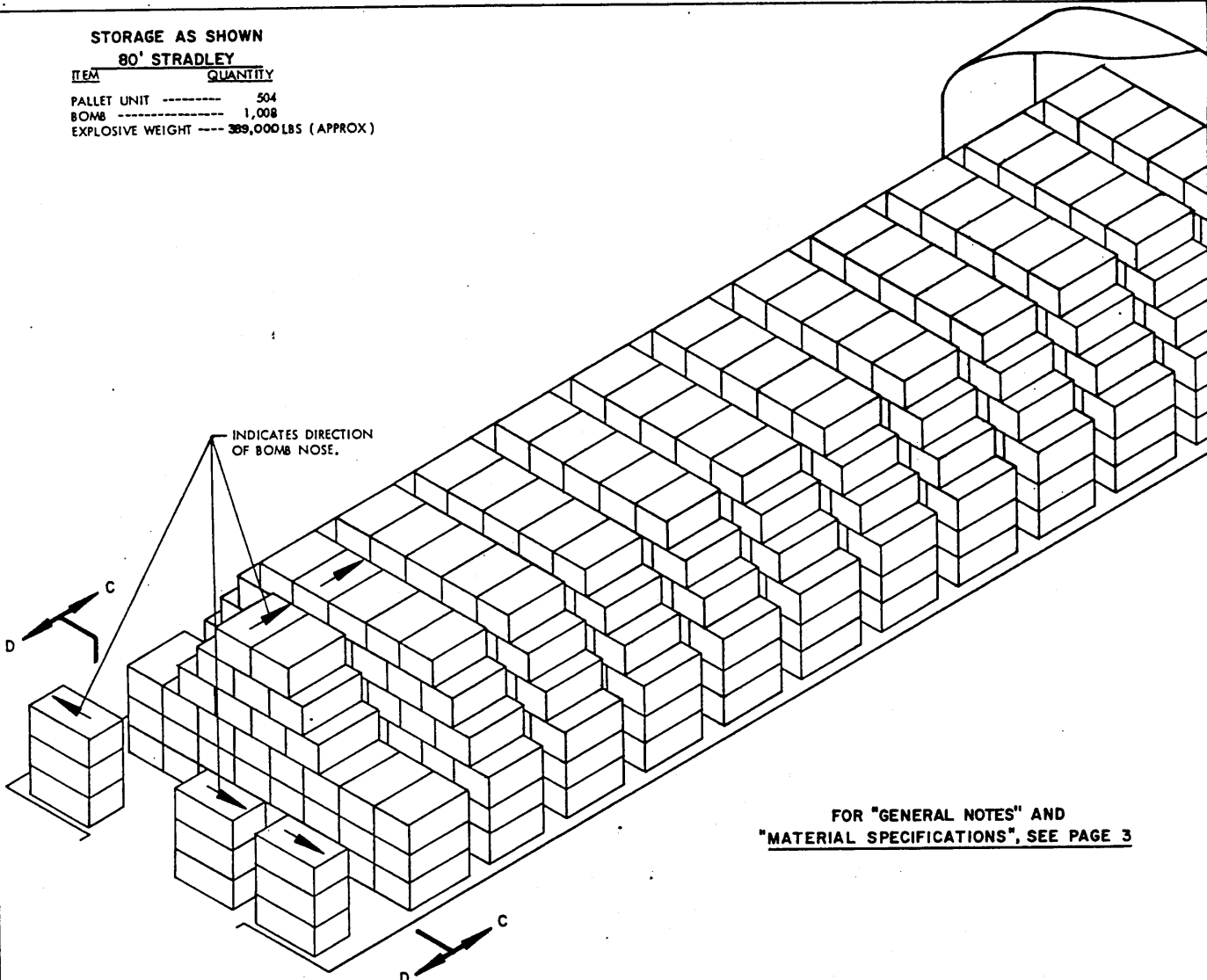

FOR "GENERAL NOTES" AND
"MATERIAL SPECIFICATIONS", SEE PAGE 3

ISOMETRIC VIEW
(80' STRADLEY MAGAZINE)

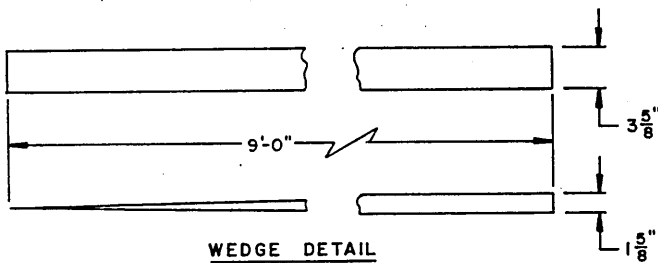

WEDGE DETAIL

BILL OF MATERIAL (PER 42-UNIT STACK)		
LUMBER	LINEAR FEET	BOARD FEET
1" X 2"	57	10
1" X 4"	255	85
3" X 4"	105	105
NAILS	NO. REQD	POUNDS
4d (1-1/2")	136	1/2
12d (3-1/4")	136	2-1/2
WEDGES	NO. REQD	
2" X 4" X 9'-0"	4	

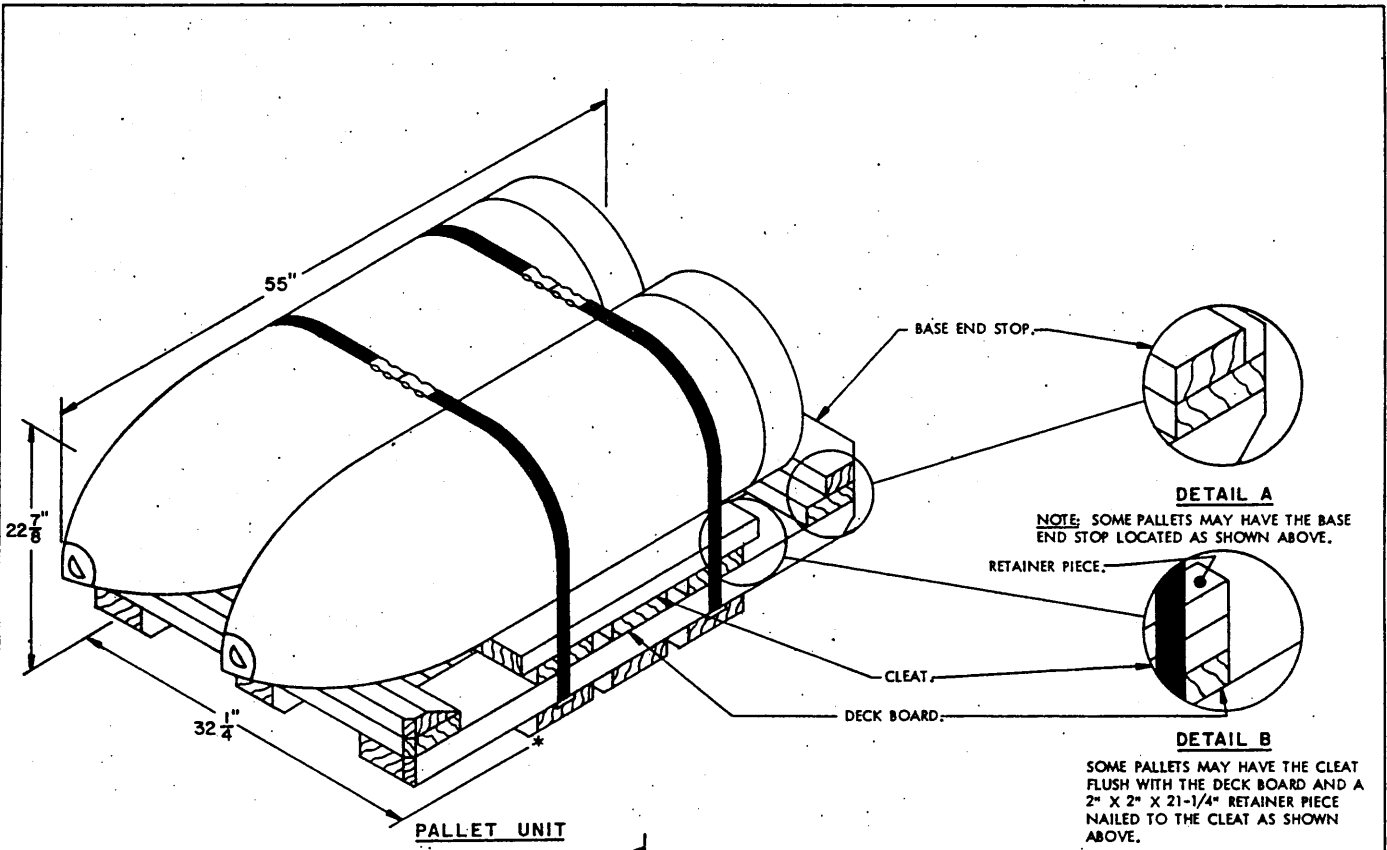

PALLET UNIT
 THE TPO 1325-926-1868 UNIT
 IS SHOWN ABOVE.

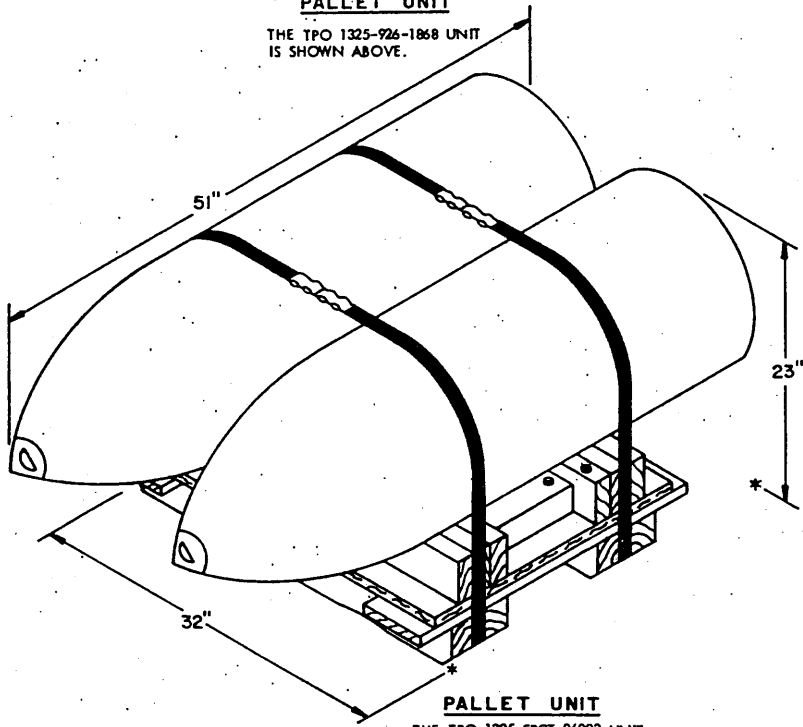

PALLET UNIT
 THE TPO 1325-SPCT-06003 UNIT
 IS SHOWN ABOVE.

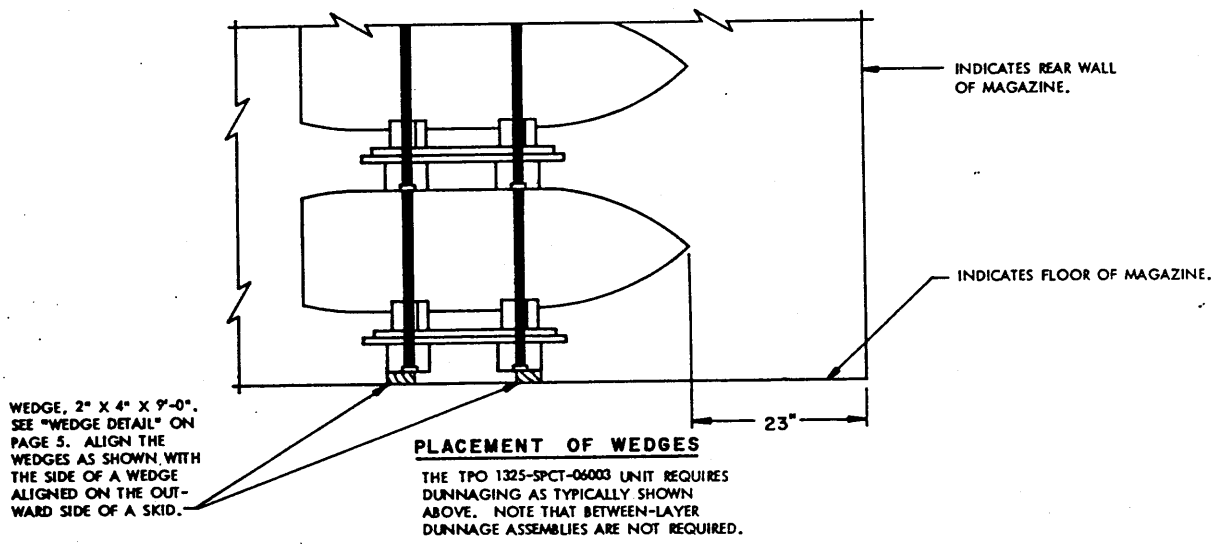
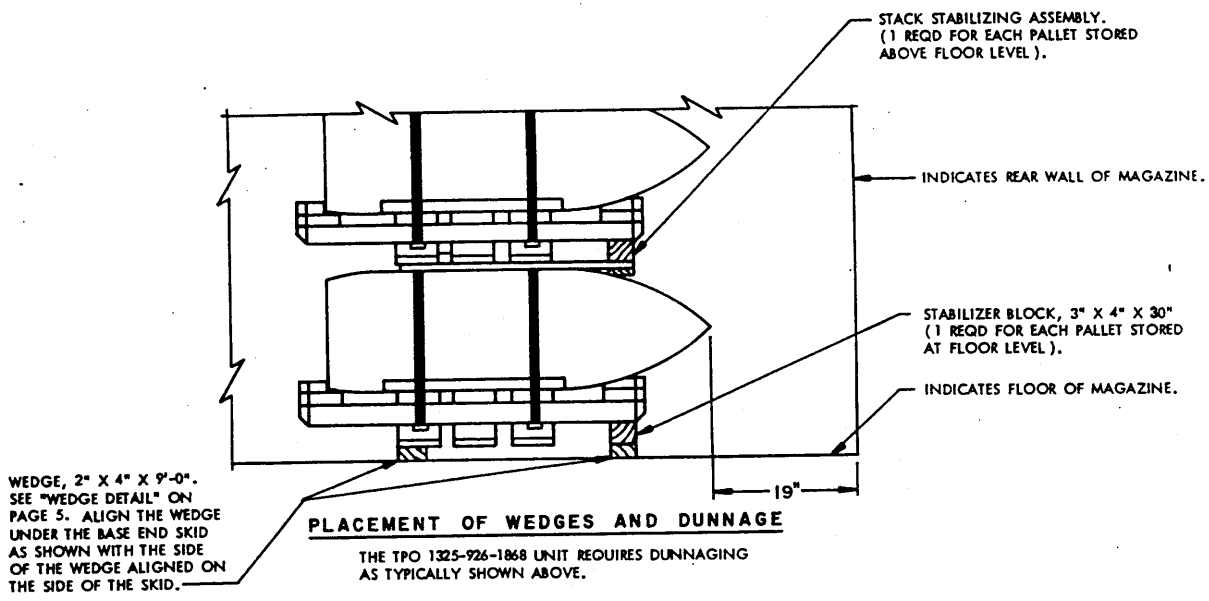

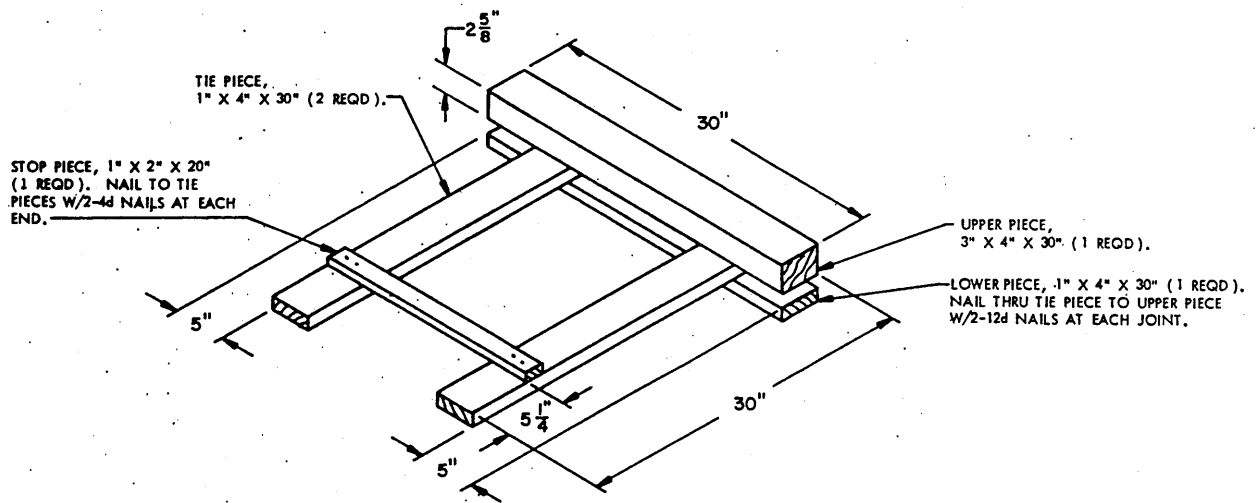

STACK STABILIZING ASSEMBLY

ASSEMBLY IS ONLY TO BE USED WITH TPO 1325-926-1868 PALLET UNIT. (1 REQD WITH EACH PALLET STORED ABOVE FLOOR LEVEL). NOTE THAT IF 3" X 4" MATERIAL IS NOT AVAILABLE, THE "UPPER PIECE" CAN BE MADE BY LAMINATING MATERIAL OF OTHER THICKNESSES, SUCH AS PROVIDED BY 2" X 4" AND 1" X 4" PIECES.