

BASIC PROCEDURES

UNITIZATION PROCEDURES FOR COMPLETE ROUNDS PACKED IN CYLINDRICAL METAL OR PLASTIC CONTAINERS ON 4-WAY ENTRY PALLETS

INDEX

<u>ITEM</u>	<u>PAGE(S)</u>
GENERAL NOTES AND MATERIAL SPECIFICATIONS - - - - -	2-4
PROVISIONS FOR LESS-THAN-FULL-LAYER UNIT LOADS - - - - -	5
TYPICAL PALLET UNIT WITH CONTAINERS UNITIZED VERTICALLY - - - - -	6-7
TYPICAL PALLET UNIT WITH CONTAINERS UNITIZED HORIZONTALLY - - - - -	8-9
UNIT ASSEMBLY TOLERANCE DETAILS - - - - -	10

THIS DRAWING SUPERCEDES THE PALLET UNIT DETAIL PORTIONS DELINEATED ON PAGES 2 THRU 11 OF DRAWING 19-48-4079-1-2-5-11-14PM1001, DATED SEPTEMBER 1969. HOWEVER THE PALLET UNIT DATA WITHIN DRAWING 19-48-4079-1-2-5-11-14PM1001 WILL CONTINUE TO BE VALID FOR EACH ITEM LISTED WITHIN THAT DRAWING UNTIL SUPERSEDED BY AN APPENDIX TO THIS DOCUMENT FOR THAT ITEM.

NOTICE:

THIS BASIC PROCEDURES DRAWING WILL BE AUGMENTED BY SEPARATELY ISSUED APPENDICES BEARING THE DRAWING AND FILE NUMBERS OF THIS DOCUMENT. AN APPENDIX WILL DELINEATE THE APPROVED CONFIGURATIONS OF A UNIT LOAD FOR A SPECIFIC SERIES CONTAINER WITH AMMUNITION ITEMS. APPENDICES CANNOT STAND ALONE, BUT MUST BE USED IN CONJUNCTION WITH THE BASIC PROCEDURES DRAWING. THE DRAWING NUMBER OF EACH APPENDIX WILL CONTAIN A SUB-NUMBER FOR IDENTIFICATION (E.G., THE DRAWING NUMBER FOR APPENDIX 2 WILL BE 19-48-4079/2-20PM1002)

DISTRIBUTION STATEMENT A:

APPROVED FOR PUBLIC RELEASE
DISTRIBUTION IS UNLIMITED.

U.S. ARMY MATERIEL COMMAND DRAWING

APPROVED, U.S. ARMY RESEARCH, DEVELOPMENT AND ENGINEERING COMMAND REHMSTEDT.MA RK.J.1230548400 <small>Digitally signed by REHMSTEDT.MARK.J.1230548400 DN: cn=CASILLAS, ou=U.S. Government, ou=DoD, ou=PKI, ou=USA, c=US Date: 2011.08.11 14:06:25 -0500</small>		CAUTION: VERIFY PRIOR TO USE AT WWW.DAC.ARMY.MIL THAT THIS IS THE MOST CURRENT VERSION OF THIS DOCUMENT. THIS IS PAGE 1 OF 10.			
APPROVED, U.S. ARMY JOINT MUNITIONS COMMAND CASILLAS.GILBE RT.J.1230393644 <small>Digitally signed by CASILLAS.GILBERT.J.1230393644 DN: cn=CASILLAS, ou=U.S. Government, ou=DoD, ou=PKI, ou=USA, c=US Date: 2011.08.15 09:53:30 -0500</small>		DO NOT SCALE		JANUARY 1981	
APPROVED BY ORDER OF COMMANDING GENERAL, U.S. ARMY MATERIEL COMMAND CARNEY.GARY.BURTON.1038708038 <small>Digitally signed by CARNEY.GARY.BURTON.1038708038 DN: cn=CARNEY.GARY.BURTON, ou=U.S. Government, ou=DoD, ou=PKI, ou=USA, c=US Date: 2011.08.15 07:45:17 -0500</small>		ENGINEER OR TECHNICIAN REV.	WILLIAM R. FRERICHS MADELINE BANKS	REVISION NO. 4	JUNE 2011
TRANSPORTATION ENGINEERING DIVISON		FIEFFER.LAURA.A.1230375727 <small>Digitally signed by FIEFFER.LAURA.A.1230375727 DN: cn=CASILLAS, ou=U.S. Government, ou=DoD, ou=PKI, ou=USA, c=US Date: 2011.04.28 15:37:38 -0500</small>		SEE THE REVISION LISTING ON PAGE 4	
VALIDATION ENGINEERING DIVISON		BARICKMAN.PHILIP.W.1230202202 <small>Digitally signed by BARICKMAN.PHILIP.W.1230202202 DN: cn=CASILLAS, ou=U.S. Government, ou=DoD, ou=PKI, ou=USA, c=US Date: 2011.04.28 15:36:55 -0500</small>		CLASS	DIVISION
ENGINEERING DIRECTORATE		BEAVER.JERRY.W.1230949952 <small>Digitally signed by BEAVER.JERRY.W.1230949952 DN: cn=CASILLAS, ou=U.S. Government, ou=DoD, ou=PKI, ou=USA, c=US Date: 2011.05.02 07:55:59 -0500</small>		DRAWING	FILE
U.S. ARMY DEFENSE AMMUNITION CENTER		19	48	4079	20PM1002

GENERAL NOTES

- A. THIS DOCUMENT HAS BEEN PREPARED AND ISSUED IN ACCORDANCE WITH AR 740-1 AND AUGMENTS TM 743-200-1 (CHAPTER 5) AND CONFORMS TO MIL-STD-1660.
- B. APPROVED SPECIFICATIONS, COVERING THE ASSEMBLAGE AND UNITIZATION OF COMPLETE ROUNDS INTO UNIT LOADS, ARE SET FORTH IN THIS DRAWING. THIS DRAWING WILL BE CONSIDERED THE BASIC DOCUMENT FOR THE UNITIZATION OF COMPLETE ROUNDS PACKED IN CYLINDRICAL METAL OR PLASTIC CONTAINERS, EXCEPT FOR SOME RESTRICTED ITEMS. THIS DOCUMENT INCLUDES MATERIAL SPECIFICATIONS AND UNITIZING STANDARDS APPLICABLE TO UNITIZATION, PLUS INFORMATION RELATIVE TO TYPICAL POSITIONING OF COMPLETE ROUNDS ON A PALLET AND INSTALLATION OF UNITIZING STEEL STRAPPING. FOR TYPICAL UNITIZATION PROCEDURES AND TYPICAL FILLER ASSEMBLIES, SEE PAGES 6 THRU 9. ADDITIONALLY, "PROVISIONS FOR LESS-THAN-FULL-LAYER UNIT LOADS" ARE SPECIFIED ON PAGE 5.
- C. APPENDICES PERTAINING TO THIS BASIC DOCUMENT WILL BE ISSUED SEPARATELY. HOWEVER, ALL APPENDICES ARE A PART OF THIS BASIC PROCEDURE DRAWING. EACH APPENDIX WILL COVER THE APPROVED CONFIGURATIONS FOR A UNIT LOAD, THE SPECIFIC UNITIZATION SPECIFICATIONS, AND THE PERTINENT TABULAR DATA FOR ONE SPECIFIC SERIES CONTAINER.
- D. GENERALLY, UNIT LOADS SHOWN IN THE APPENDICES WILL CONFORM TO THE STANDARDS LISTED BELOW.
- GROSS WEIGHTS OF PALLETIZED UNIT LOADS ARE BASED ON AN OPTIMUM WEIGHT OF 2,464 POUNDS, DUE TO MATERIAL HANDLING EQUIPMENT CONSIDERATIONS. UNLESS SPECIFICALLY RESTRICTED BY ANOTHER AUTHORITY DOCUMENT, THE MAXIMUM GROSS WEIGHT OF AMMUNITION UNIT LOADS IS 4,000 POUNDS. MAXIMUM SIZE CRITERIA WILL BE AS SHOWN BY "SIZE CRITERIA" DETAIL ON PAGE 5.
 - PALLETIZED UNITS OF COMPLETE ROUNDS ARE LIMITED TO NOT MORE THAN TWO LOTS PER UNIT, EXCEPT WHERE REQUIRED BY BALLISTIC SAMPLE SHIPMENT OR TROOP USE AT POST, CAMP, OR STATION. THESE UNITS ARE FURTHER RESTRICTED TO NOT MORE THAN ONE LOT PER CONTAINER WITHIN A PALLETIZED UNIT. SEE GENERAL NOTE "S" ON PAGE 3.
 - THE UNIT LOAD SHOULD EITHER SLIGHTLY OVERHANG THE PALLET OR BE FLUSH WITH THE PALLET ON ALL FOUR SIDES. WHEN IT IS NECESSARY TO ENLARGE THE LOAD TO MATCH THE DIMENSIONS OF THE PALLET, THE DUNNAGE ASSEMBLIES WILL BE CONSTRUCTED IN SUCH A MANNER THAT THE CONTAINERS ARE HELD IN PLACE AND THE PALLET IS FILLED OUT COMPLETELY.

(CONTINUED AT RIGHT)

MATERIAL SPECIFICATIONS

- PALLET:** - - - - - : MIL SPEC MIL-P-15011; 4 WAY ENTRY, STYLE 1, 1A, OR 1B, TYPE I CLASS 1, PRESERVATIVE AND HEAT TREATED. SEE GENERAL NOTE "BB" ON PAGE 4.
- LUMBER:** - - - - - : SEE TM 743-200-1 (DUNNAGE LUMBER) AND VOLUNTARY PRODUCT STANDARD PS 20 FOR FILLER ASSEMBLIES. ASTM D6199; CLASS 2, GROUP II, III, OR IV, PRESERVATIVE AND HEAT TREATED FOR STRAPPING BOARDS AND TOP INTERMEDIATE, AND PALLET DUNNAGE ASSEMBLIES. **NOTE:** ONLY GROUP IV LUMBER IN ACCORDANCE WITH ASTM D6199 WILL BE ACCEPTABLE FOR THE CONSTRUCTION OF THE PALLET. SEE GENERAL NOTES "X" AND "BB" ON PAGE 3.
- NAILS:** - - - - - : ASTM F1667; COMMON STEEL NAIL (NLCMS OR NLCCMS), ALT: UNDERLAYMENT NAIL (NLUN), PALLET NAIL (NLPL), OR COOLER NAIL (NLCL) OF THE SAME SIZE. SEE GENERAL NOTE "Z" ON PAGE 3.
- PLYWOOD:** - - - - - : COMMERCIAL ITEM DESCRIPTION A-A-55057, TYPE A, CONSTRUCTION AND INDUSTRIAL PLYWOOD, INTERIOR WITH EXTERIOR GLUE, GRADE C-D. IF SPECIFIED GRADE IS NOT AVAILABLE, A BETTER INTERIOR OR AN EXTERIOR GRADE MAY BE SUBSTITUTED.
- STRAPPING, STEEL:** - - - - - : ASTM D3953; FLAT STRAPPING, TYPE 1, HEAVY DUTY, FINISH B (GRADE 2), SIZE 3/4" X .035" OR .031" OR .029". ALTERNATIVE SIZE 1-1/4" X .035" OR .031" OR .029". **NOTE:** IF EDGES DO NOT MEET THE PRECEC TEST FOR GRADE 2, ANY BRITTE OR SLIT EDGES SHALL HAVE FINISH A OVERLAY APPLIED.
- SEAL, STRAP:** - - - - - : ASTM D3953; CLASS H, FINISH B (GRADE 2), DOUBLE NOTCH TYPE, STYLE I, II, III, OR IV. ALTERNATIVE SEAL FINISH: SIGNODE OR DELTA PAINTED SEALS MAY BE USED AS AN ALTERNATIVE IF ALL SURFACES ARE PAINTED. GRI TTED BACKING IS NOT PERMITTED.
- STAPLE:** - - - - - : ASTM F1667; STFCs-189 OR STFCs-207, 15/16" OR 1" CROWN WIDTH X 3/4" LEG LENGTH FOR 3/4" STRAPPING OR STFCs-224 1-17/32" CROWN WIDTH X 3/4" LEG LENGTH FOR 1-1/4" STRAPPING.

(GENERAL NOTES CONTINUED)

- A UNIT LOAD, SUCH AS THE LAST UNIT LOAD FOR A COMPLETE ROUND LOT, CAN BE ASSEMBLED WITH LESS LAYERS THAN SPECIFIED FOR THE BASIC UNIT LOAD. HOWEVER, UNIT LOADS, INCLUDING PARTIAL UNIT LOADS, WILL NOT BE ASSEMBLED WITH A PARTIAL LAYER. EMPTY CONTAINERS OR DUNNAGE WILL BE USED TO ACHIEVE FULL-LAYER UNIT LOADS. FOR SPECIFIC GUIDANCE, SEE THE "PROVISIONS FOR LESS-THAN-FULL-LAYER UNIT LOADS" ON PAGE 5.
- ANY REQUEST FOR DEVIATION FROM THE STANDARDS DESCRIBED IN GENERAL NOTE "D" OR FROM THE PROCEDURES DELINEATED IN AN APPENDIX MUST BE DIRECTED TO THE COMMANDER, U. S. ARMY RDECOM-ARDEC, ATTN: RDAR-EIL-TP, ROCK ISLAND, IL 61299-7300, FOR SPECIFIC APPROVAL. FOR EXAMPLE, SPECIFIC APPROVAL MUST BE OBTAINED FOR UNITIZATION OF AN ITEM WHEN PACKED IN CYLINDRICAL CONTAINERS WHICH ARE DIFFERENT IN SIZE THAN THOSE SHOWN IN THE APPENDIX FOR THAT ITEM, EVEN THOUGH THE UNIT LOAD MAY COMPLY WITH THE STANDARDS DESCRIBED IN GENERAL NOTE "D".
- COMPLETE ROUNDS IN CYLINDRICAL CONTAINERS UNITIZED PRIOR TO DISTRIBUTION OF THIS DRAWING OR OF AN APPENDIX THERETO, NEED NOT BE REUNITIZED SOLELY TO CONFORM TO THE STANDARDS SPECIFIED HEREIN OR TO THE METHOD SHOWN IN AN AUGMENTING APPENDIX. HOWEVER, CONTAINER AND STRAP ALIGNMENT MUST CONFORM WITH THE TOLERANCE STANDARDS SPECIFIED ON PAGE 10 OF THIS DRAWING BEFORE A UNIT IS ACCEPTABLE FOR SHIPMENT. ALSO, THE CONDITION OF THE UNITIZING STRAPPING ON A UNIT LOAD MUST COMPLY WITH THE CRITERIA OF GENERAL NOTE "N" BELOW.
- UNIT LOADS MUST ONLY BE MADE UP WITH FULL LAYERS. HOWEVER, FOR REDUCED QUANTITIES, ONE OR MORE FULL LAYERS MAY BE OMITTED, AND/OR A LAYER MAY CONSIST OF LOADED CONTAINERS AND A FILLER ASSEMBLY OR AN EMPTY CONTAINER(S). SEE THE "PROVISIONS FOR LESS-THAN-FULL LAYER UNIT LOADS" ON PAGE 5. ONLY ONE PALLETIZED UNIT HAVING A REDUCED QUANTITY OF CONTAINERS SHOULD BE PERMITTED PER LOT FOR THAT ITEM. CARE SHALL BE TAKEN TO INSURE THAT REDUCED-QUANTITY UNITS ARE EVENLY ALIGNED HORIZONTALLY AND VERTICALLY SO THAT THE SIDES AND ENDS OF THE UNIT LOAD DO NOT EXCEED 1/2" TOLERANCE, RELATIVE TO THE PALLET. SEE "UNIT ASSEMBLY TOLERANCES" DETAILS ON PAGE 10.
- DIMENSIONAL LUMBER SPECIFIED THROUGHOUT THIS PROCEDURAL DRAWING IS OF NOMINAL SIZE UNLESS OTHERWISE SPECIFIED. FOR EXAMPLE, 1" X 4" MATERIAL IS ACTUALLY 3/4" THICK BY 3-1/2" WIDE AND 2" X 6" MATERIAL IS ACTUALLY 1-1/2" THICK BY 5-1/2" WIDE. IF THE 1" X 2", 2" X 2", OR 2" X 3" DUNNAGE LUMBER SPECIFIED IN THE APPENDICES IS NOT READILY AVAILABLE, TWO ACCEPTABLE SIZE DUNNAGE PIECES CAN BE MADE BY RIPPING (SAWING) A PIECE OF NOMINAL SIZE 1" X 4", 2" X 4", OR 2" X 6" LUMBER RESPECTIVELY, ON THE CENTER LINE OF ITS WIDTH.
- UNLESS OTHERWISE SPECIFIED, A PLUS-OR-MINUS 1/4" IS ALLOWED ON OVERALL DIMENSIONS OF ANY PIECE OF DUNNAGE OR DUNNAGE ASSEMBLY. HOWEVER, SIMILAR PIECES IN AN ASSEMBLY MUST BE WITHIN 1/8" OF THE SAME DIMENSION.
- IN ORDER TO OBTAIN COMPACT (SOUND) UNITS, ALL STRAPS SHALL BE LOCATED IN PROPER ALIGNMENT AND TENSIONED UNTIL THEY CUT INTO THE EDGE OF THE STRAPPING BOARDS OR TOP DUNNAGE ASSEMBLY AND THE PALLET WITHOUT DAMAGING THE CONTAINER OR CONTENTS. AFTER TENSIONING, ALL STRAPS WILL BE SECURED USING ONE SEAL AND TWO PAIR OF NOTCHES PER SEAL. SEE "UNIT ASSEMBLY TOLERANCES" DETAILS ON PAGE 10. SEALS MAY BE LOCATED ON A SIDE OR ON THE TOP OF THE UNIT, AS REQUIRED BY OPERATIONAL NECESSITY.
- WHEN APPLYING ANY STRAP, CARE MUST BE EXERCISED TO ASSURE THAT THE END OF THE STRAP ON THE UNDERSIDE OF THE JOINT EXTENDS AT LEAST 6" BEYOND THE SEAL. THIS EXTRA MINIMUM LENGTH OF STRAP IS REQUIRED TO PERMIT SUBSEQUENT TIGHTENING OF LOOSENED STRAPPING. RETENSIONING CAN BE ACCOMPLISHED WITHOUT REPLACING STRAPPING OR SPLICING STRAPPING THROUGH THE USE OF A TENSIONING TOOL, MANUAL OR PNEUMATIC, AND THE APPLICATION OF ONE ADDITIONAL SEAL. SEE THE "STRAP RETENSIONING TAB" DETAIL ON PAGE 10.
- DETERMINATION OF LENGTH OF STRAPPING. THE FOLLOWING DEFINITIONS APPLY:
L = LENGTH OF STRAP REQUIRED IN INCHES
A = LENGTH OF UNIT IN INCHES
W = WIDTH OF UNIT IN INCHES
H = HEIGHT OF UNIT, INCLUDING PALLET, IN INCHES
 - THE LENGTH OF A LOAD STRAP REQUIRED FOR A SPECIFIC UNIT, WHERE THE STRAP PASSES THROUGH THE STRAP SLOT OR ABOVE THE PALLET DECK, WILL BE DETERMINED USING THE FOLLOWING FORMULA: $L = 2W + 2H + 2$.
 - THE LENGTH OF A TIEDOWN STRAP REQUIRED FOR A SPECIFIC UNIT, WHERE THE STRAP PASSES UNDER THE PALLET DECK, WILL BE DETERMINED BY USING THE FOLLOWING FORMULA: $L = 2A + 2H + 2$.
- PALLET UNIT LOADS SHALL BE INSPECTED FOR TORN, DETERIORATED OR LOOSENED STRAPPING PRIOR TO SHIPPING.
 - TORN OR BROKEN STRAPS SHOULD BE REPLACED OR REPAIRED BY SPLICING IN A MANNER SIMILAR TO THAT DESCRIBED IN "N.4.(B)" ON PAGE 3.
 - DETERIORATION DUE TO A MINOR AMOUNT OF RUST WILL NOT NECESSARILY BE CAUSE FOR REPLACING A STRAP. HOWEVER, AN EXTENSIVELY RUSTED/SCALED/PITTED STRAP IS CAUSE FOR REPLACING THE STRAP.

(CONTINUED ON PAGE 3)

(GENERAL NOTES CONTINUED FROM PAGE 2)

3. A DAMAGED OR DEFECTIVE SEAL IS SUFFICIENT CAUSE FOR REPLACEMENT OF THE SEAL.
4. LOOSE STRAPS SHOULD BE CHECKED FOR DEGREE OF LOOSENESS BY POSITIONING THE HOOK OF A SCALE (COMMONLY KNOWN AS A FISH SCALE) BEHIND THE STRAPS NEAR THE MIDPOINT AT THE TOP OR SIDE OF THE UNIT LOAD. PULL THE SCALE UNTIL A READING OF 20 POUNDS IS OBTAINED. THE DISTANCE A STRAP IS OUT OF ALIGNMENT MUST NOT EXCEED 1-1/2". IF THE MEASUREMENT EXCEEDS 1-1/2", THE STRAP MUST BE TIGHTENED OR REPLACED. SEE PAGE 10 FOR GUIDANCE. TIGHTENING CAN BE ACCOMPLISHED BY EITHER OF TWO METHODS.
 - (A) A RETENSIONING DEVICE CAN BE USED IF THE STRAP HAS AT LEAST A 6" LONG TAB AT THE SEAL. SEE GENERAL NOTE "L" FOR GUIDANCE.
 - (B) AN 18" OR LONGER STRAP CAN BE USED AS A SPLICE PIECE. CUT THE LOOSE STRAP ON BOTH SIDES OF THE ORIGINAL SEAL AND DISCARD THE CUT OUT SECTION. OVERLAP ONE END OF THE ORIGINAL STRAPPING SO AS TO PROTRUDE SLIGHTLY BEYOND THE END OF THE SEAL TO BE USED. POSITION AND SECURE SEAL TO OVERLAPPED SECTION WITH TWO PAIR OF NOTCHES. USING A STRAPPING TOOL, TENSION AND SEAL THE LENGTHENED STRAP. THE STRAP SPLICE PIECE MAY BE CUT FROM NEW STRAP OR USED STRAP (BENDS IN THE USED STRAP PIECE ARE NOT PERMITTED), PROVIDED IT IS AT LEAST OF AS GOOD A QUALITY AS THE STRAP TO WHICH IT IS BEING SECURED. **NOTE:** ONLY ONE SPLICE PER STRAP IS ALLOWED ON UNIT LOADS OF AMMUNITION.
 - (C) **CAUTION:** WHEN A STRAP IS REPLACED/SPLICED OR RETENSIONED, AND THE OTHER STRAPS ON A UNIT LOAD ARE NOT, CARE MUST BE EXERCISED TO INSURE THAT THE TENSION ON THE AFFECTED STRAP IS NEARLY THE SAME AS THAT OF THE OTHER STRAPS.
- O. USE OF OTHER THAN "FINISH B" STRAPPING IS A DEVIATION FROM APPROVED PROCEDURES AND IS SUBJECT TO REQUIREMENTS OF GENERAL NOTE "E" ON A CASE BY CASE BASIS.
- P. OUTLOADING AND STORAGE OF PALLET UNITS OF COMPLETE ROUNDS SHALL BE ACCOMPLISHED IN ACCORDANCE WITH THE APPLICABLE PROCEDURAL DRAWINGS AS IDENTIFIED IN THE SPECIFIC APPENDICES. THESE DRAWINGS ARE AVAILABLE ON THE INTERNET AT [HTTPS://WWW3.DAC.ARMY.MIL/DET](https://www3.dac.army.mil/det). CONTACT THE DEFENSE AMMUNITION CENTER AT ABOVE WEB ADDRESS IF SPECIFIC STORAGE AND OUTLOADING DRAWINGS ARE NOT IDENTIFIED WITHIN A PARTICULAR APPENDIX.
- Q. IF STRAP CUTTERS ARE SPECIFICALLY REQUIRED BY THE PROCURING ACTIVITY, REFER TO DARCOM DRAWING 19-48-4127-20P1000 FOR APPROPRIATE MEANS OF SECUREMENT TO THE PALLET UNIT.
- R. UNIT LOAD MARKING AND BAR CODE APPLICATION WILL BE ACCOMPLISHED IN ACCORDANCE WITH DAC DRAWING ACV00561.
- S. IF UNITIZING OPERATIONS ARE BEING PERFORMED IN SUPPORT OF A SHIPMENT OF ITEMS FOR TROOP USE AT A CAMP, POST OR STATION, AND, IF IN ADDITION TO FULL LAYER UNITS SPECIFIED IN GENERAL NOTE "G", A FEW LOOSE CONTAINERS ARE REQUIRED TO SATISFY THE QUANTITY REQUISITIONED, THE LOOSE CONTAINERS NEED NOT BE UNITIZED. HOWEVER, THE METHOD FOR BRACING AND STAYING OF THE LOOSE CONTAINERS WITHIN THE LOAD TO BE SHIPPED MUST COMPLY WITH METHODS SPECIFIED WITHIN THE APPLICABLE 19-48 SERIES OUTLOADING PROCEDURAL DRAWINGS.
- T. CONVERSION TO METRIC EQUIVALENTS: DIMENSIONS WITHIN THIS DOCUMENT ARE EXPRESSED IN INCHES, AND WEIGHTS ARE EXPRESSED IN POUNDS. WHEN NECESSARY, THE METRIC EQUIVALENT MAY BE COMPUTED ON THE BASIS OF ONE INCH EQUALS 25.4MM AND ONE POUND EQUALS 0.454 KG.

(CONTINUED AT RIGHT)

(GENERAL NOTES CONTINUED)

- U. WHEN ASSEMBLING A COMPLETE PALLET UNIT, CARE SHALL BE TAKEN TO INSURE THAT THE CONTAINERS AND DUNNAGE ASSEMBLIES OR PIECES ARE EVENLY ALIGNED SO THAT THE SIDES AND ENDS OF THE PALLET UNIT DO NOT EXCEED A 1/2" TOLERANCE, RELATIVE TO THE PALLET. SEE "UNIT ASSEMBLY TOLERANCES" DETAILS ON PAGE 10.
- V. DIMENSIONS GIVEN FOR DUNNAGE ASSEMBLIES WILL BE FIELD CHECKED PRIOR TO THEIR ASSEMBLY. CONTAINERS MUST FIT SNUGLY IN THE DUNNAGE ASSEMBLIES. THIS GUIDANCE MUST BE APPLIED PRIOR TO BEGINNING A PALLETIZING OPERATION. ALSO, DUE TO VARIATION OF CONTAINER DIMENSIONS, ADJUSTMENTS MAY BE REQUIRED AS TO THE LOCATION OF CERTAIN PIECES ON DUNNAGE ASSEMBLIES.
- W. FILLER ASSEMBLIES ARE DESIGNED SO AS TO PROVIDE LATERAL AND LONGITUDINAL BRACING WITHIN THE UNIT LOAD EQUAL TO OR GREATER THAN THE STRENGTH OF THE CONTAINER(S) BEING OMITTED FROM A LAYER. WHEN A FILLER ASSEMBLY IS REQUIRED TO BE USED WITHIN A UNIT LOAD, THE CONSTRUCTION SPECIFICATION AND DETAILS WILL BE PROVIDED IN THE APPLICABLE APPENDIX FOR THE ITEM TO BE UNITIZED. FOR TYPICAL FILLERS FOR OMITTED CONTAINERS, SEE PAGES 7 AND 9.
- X. ALL WOODEN DUNNAGE USED IN UNIT LOADS SHALL BE PRESERVATIVE TREATED IN ACCORDANCE WITH THE PROCEDURES SPECIFIED IN MIL-DTL-2427 FOR CLEATED WOODEN BOXES. IF THE DUNNAGE CONSISTS OF MORE THAN ONE COMPONENT, IT MUST BE ASSEMBLED PRIOR TO TREATMENT. THE LETTERS PA DENOTING PQ56 (COPPER-8-QUINOLINOLATE), PB DENOTING M-GARD W550 (ZINC NAPHTHENATE EMULSIFIABLE) OR PC DENOTING M-GARD W510 OR CUNAPSOL 5 (COPPER NAPHTHENATE) MUST BE APPLIED TO THE WOOD DUNNAGE IN LETTERS AT LEAST ONE-INCH HIGH.
- Y. GENERAL NOTE "D.2" ON PAGE 2 SPECIFIES THAT NO MORE THAN TWO LOTS OF AMMUNITION WILL BE CONTAINED ON A PALLET UNLESS IN SUPPORT OF BALLISTIC SAMPLE SHIPMENT OR TROOP USE AT POST, CAMP, OR STATION. THAT PORTION OF THE AFOREMENTIONED NOTE WHICH LIMITS PALLET UNIT TO NOT MORE THAN TWO LOTS IS INTENDED TO BE APPLIED TO PALLETIZING OPERATIONS BEING PERFORMED AT A LOAD, ASSEMBLE AND PACK PLANT, OR TO MAJOR MAINTENANCE OPERATIONS BEING PERFORMED AT ANY AMMUNITION DEPOT WHEN THE QUANTITY OF BOXES COMPRISING A LOT IS GREAT ENOUGH TO CONSTRUCT MORE THAN ONE PALLET UNIT. **NOTICE:** MULTIPLE (MORE THAN TWO) LOTS ARE PERMITTED TO BE PALLETIZED TOGETHER AS A UNIT LOAD WHEN A SINGLE LOT QUANTITY IS INSUFFICIENT TO COMPLETE ONE FULL-SIZE OR REDUCED-LAYER (TO SATISFY A SMALL-QUANTITY SHIPMENT) UNIT LOAD. MULTIPLE LOTS ON A PALLET WILL BE OF THE SAME NSN AND WILL BE UNITIZED IN ACCORDANCE WITH THE APPLICABLE APPENDIX FOR THE ITEM NSN INVOLVED. MULTIPLE-LOT UNIT LOADS WILL BE MARKED IN ACCORDANCE WITH DAC DRAWING ACV00561.
- Z. COOLER NAILS MAY BE SUBSTITUTED FOR THE COMMON NAILS WITHIN EACH APPENDIX BY APPLYING THE FOLLOWING GUIDANCE. THE NUMBER OF COOLER NAILS TO BE USED WILL BE THE NUMBER OF COMMON NAILS MULTIPLIED BY 1.2 ROUNDED UP TO THE NEXT WHOLE NUMBER. THE SIZE OF COOLER NAILS TO BE USED WILL BE THE SAME AS SPECIFIED FOR THE COMMON NAILS (4d, 6d, 10d, ETC.) BUT WILL CONFORM TO THE SIZE AND WEIGHT TOLERANCES SPECIFIED WITHIN ASTM F1667 FOR COOLER NAILS.
- AA. REFER TO DAC DRAWING ACV00617 FOR APPROVED SOURCES FOR SEALLESS (CLIPLESS) SEALING TOOL. THESE APPROVED SEALING TOOLS CAN BE USED IN PLACE OF SEALS CURRENTLY SPECIFIED IN THE MATERIAL SPECIFICATIONS ON PAGE 2.
- BB. ALL NON-MANUFACTURED WOOD USED IN THE PALLETIZED LOAD SHALL BE HEAT TREATED AND MARKED TO SHOW CONFORMANCE TO THE INTERNATIONAL PLANT PROTECTION CONVENTION STANDARD (IPPC), ISPM-15. SEE DAC DRAWING ACV00831 FOR ISPM-15 CERTIFICATION MARKING AND PLACEMENT DETAILS.

REVISIONS

REVISION NO. 1, DATED MAY 1985, CONSISTS OF:

1. ADDING GENERAL NOTE "X" (PRESERVATIVE TREATMENT).
2. UPDATING DRAWING TO CONFORM TO CURRENT STANDARDS.

REVISION NO. 2, DATED FEBRUARY 2000, CONSISTS OF:

1. ADDING PLASTIC CONTAINERS TO THE TITLE.
2. UPDATING DRAWING FORMAT.
3. UPDATING GENERAL NOTES AND MATERIAL SPECIFICATIONS.

REVISION NO. 3, DATED JUNE 2003, CONSISTS OF CHANGES PER ECP R2T5302 (1 AND 2) AND ECP R2T5310 (1) INCLUDING:

1. UPDATING STRAPPING, STAPLE AND WOOD SPECIFICATIONS.
2. ADDING GENERAL "BB" (HEAT TREATMENT).

REVISION NO. 4, DATED JUNE 2011, CONSISTS OF CHANGES PER ECP R07K3013 (2) INCLUDING:

1. UPDATING DRAWING FORMAT.
2. UPDATING MATERIAL SPECIFICATIONS FOR STRAPPING.
3. UPDATING GENERAL NOTES "E" (DEVIATIONS), "P" (OUTLOADING), "X" (PRESERVATIVE TREATMENT), AND "BB" (HEAT TREATMENT).

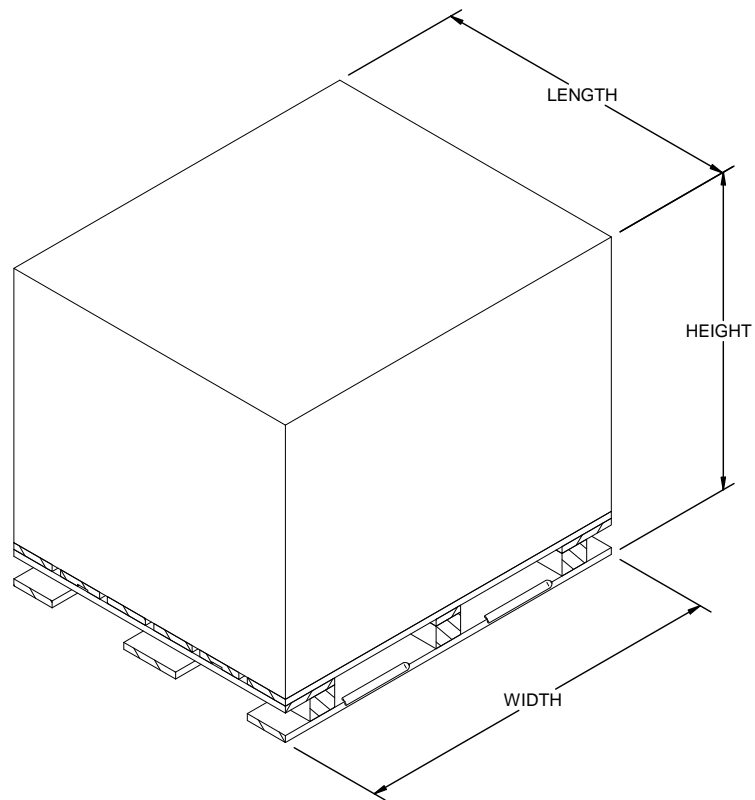

SIZE CRITERIA

MAXIMUM SIZE DIMENSIONS, SEPARATELY OR IN COMBINATION, ARE 44" LONG BY 60" WIDE BY 54" HIGH. A LENGTH NOT EXCEEDING 44" WILL PERMIT 2-WIDE LOADING IN TACTICAL CARGO VEHICLES.

PROVISIONS FOR LESS-THAN-FULL-LAYER UNIT LOADS

1. THE FOLLOWING PROVISIONS SET FORTH THE SPECIFICATIONS THAT MUST BE FOLLOWED IF A FILLER-TYPE ASSEMBLY IS TO BE USED TO ACHIEVE A FULL-LAYER PALLET UNIT.
 - A. FILLERS ARE DESIGNED FOR USE IN PLACE OF ONE OR MORE CONTAINERS OF A UNIT. FILLER ASSEMBLY DETAILS WILL BE DEPICTED IN THE APPENDIX APPLICABLE TO THE SPECIFIC ITEM TO BE UNITIZED. SEE GENERAL NOTE "W" ON PAGE 3.
 - B. FILLERS WILL BE POSITIONED IN THE TOP LAYER OR LAYERS OF THE CENTER STACK OR STACKS OF A UNIT LOAD AS SHOWN IN THE DETAILS ON PAGES 7 AND 9.
2. EMPTY CONTAINERS, PREFERABLY "REJECTS", CAN BE USED INSTEAD OF THE WOODEN DUNNAGE ASSEMBLIES SPECIFIED TO ACHIEVE A FULL-LAYER CONFIGURATION. WHEN AN EMPTY (REJECTED) CONTAINER IS USED TO FILL OUT A LAYER ON A PALLET UNIT, THEY WILL BE MARKED AS SPECIFIED IN ARDEC DRAWING NO. 12982865.
3. EACH UNIT LOAD CONTAINING ONE OR MORE EMPTY CONTAINERS WILL HAVE A WEATHER RESISTANT PLACARD APPLIED TO ONE SIDE AND ONE END OF THE PALLET UNIT. THE PLACARD WILL BE STENCILED WITH A CONTRASTING COLOR, USING LETTERS THAT ARE AS LARGE AS PRACTICAL BUT NOT LESS THAN 1/2" IN SIZE, TO READ: "THIS UNIT LOAD CONTAINS ____ EMPTY CONTAINER(S)".

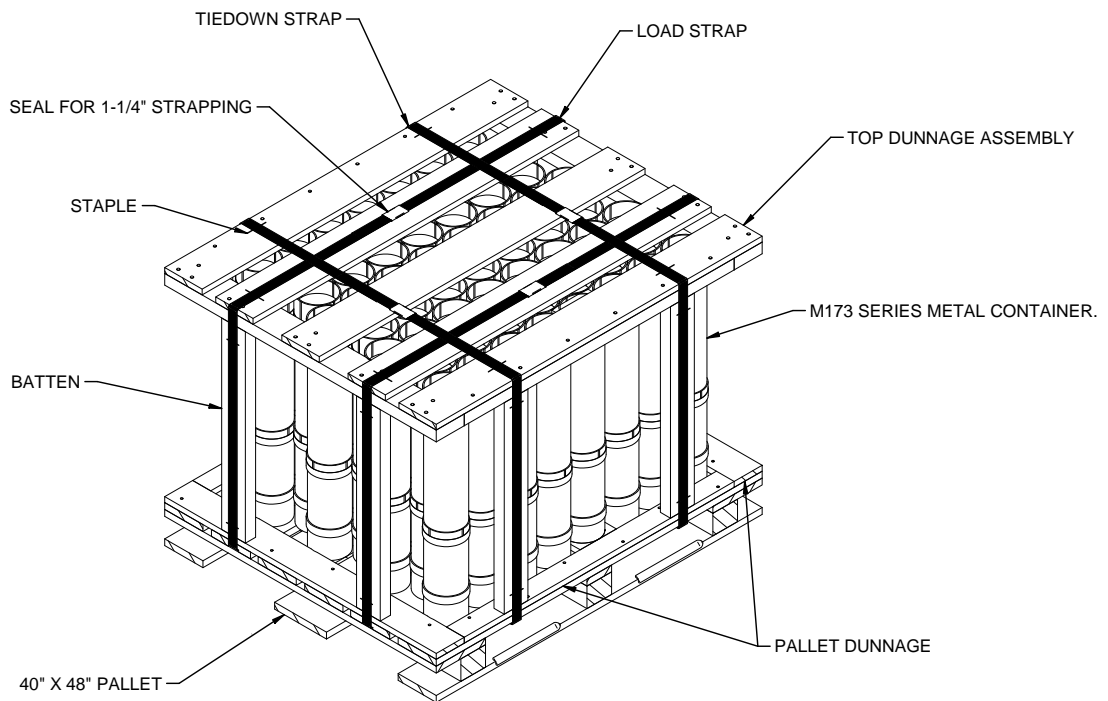

ISOMETRIC VIEW

THE M173 SERIES CONTAINER IS DEPICTED.

SPECIAL NOTES:

1. THE UNIT LOAD ABOVE DEPICTS A TYPICAL UNIT LOAD WITH THE CONTAINERS UNITIZED VERTICALLY.
2. EVEN THOUGH ONLY THE M173 SERIES CONTAINER IS DEPICTED ABOVE IN THIS LOAD CONFIGURATION, ANY OTHER SERIES CONTAINER OF A SIMILAR SIZE AND DESIGN MAY BE UNITIZED IN THIS CONFIGURATION. SEE THE APPLICABLE APPENDIX FOR SPECIFIC UNITIZATION PROCEDURAL GUIDANCE.

UNITIZING PROCEDURES

- STEP 1. POSITION PALLET IN DESIRED POSITION, WITH THE TOP DECK BOARDS UPWARDS. POSITION PALLET DUNNAGE ON PALLET AS INDICATED AND NAIL TO THE PALLET DECK BOARDS AS SHOWN. **NOTE:** NAILS MUST NOT BE DRIVEN THROUGH THE STRAP SLOTS OF THE PALLET.
- STEP 2. POSITION CONTAINERS ON PALLET AS SHOWN IN THE "LOADING PATTERN" DETAIL IN THE APPLICABLE APPENDIX. POSITION AND NAIL FILLER PIECES TO THE PALLET AND TOP DUNNAGE ASSEMBLY IF THE PALLET UNIT HAS LESS CONTAINERS THAN A FULL PALLET UNIT.
- STEP 3. POSITION TOP DUNNAGE ASSEMBLY ON CONTAINERS. POSITION BATTENS, AS SHOWN IN THE APPLICABLE APPENDIX. POSITION STRAPPING AROUND UNIT, KEEPING IN VERTICAL ALIGNMENT. SEAL EACH STRAP USING ONE SEAL, WITH TWO PAIR OF NOTCHES PER SEAL. INSTALL STRAP STAPLES AS INDICATED. SEALS SHALL BE PLACED SO AS TO NOT INTERFERE WITH THE STACKING OF ONE UNIT LOAD ON TOP OF ANOTHER.

NOTE: WHEN BUNDLING PALLET UNITS, CARE MUST BE EXERCISED TO INSURE THAT DUNNAGE ASSEMBLIES AND STRAPPING ARE IN VERTICAL ALIGNMENT. WHEN THE ASSEMBLIES AND STRAPPING ARE NOT IN VERTICAL ALIGNMENT, POOR OUTLOADING AND STORAGE PROCEDURES COULD RESULT. SEE GENERAL NOTES "G" AND "U" ON PAGES 2 AND 3 AND "UNIT ASSEMBLY TOLERANCE DETAILS" ON PAGE 10 FOR ALLOWABLE ALIGNMENT TOLERANCES.

TYPICAL PALLET UNIT WITH CONTAINERS UNITIZED VERTICALLY

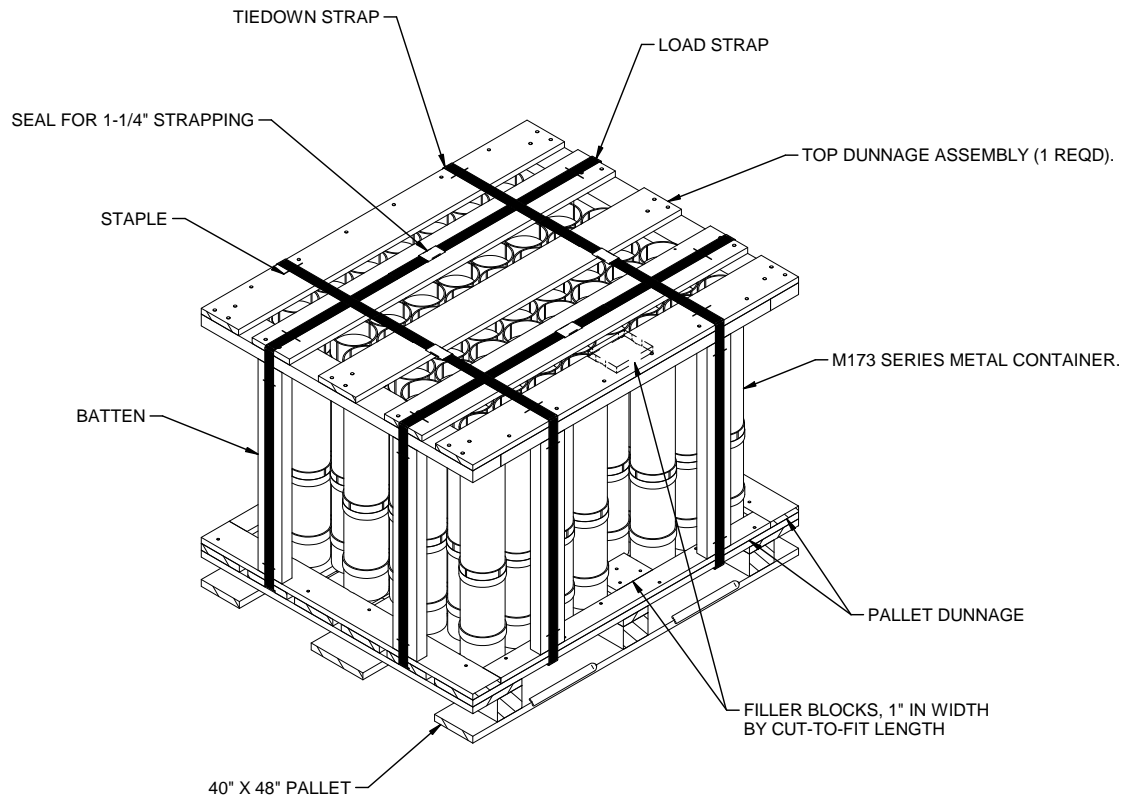

ISOMETRIC VIEW

FILLER BLOCKS FOR ONE OMITTED M173 SERIES CONTAINER ARE DEPICTED.

SPECIAL NOTE:

THE UNIT LOAD ABOVE DEPICTS A TYPICAL UNIT LOAD WITH THE CONTAINERS UN-ITIZED VERTICALLY AND FILLER BLOCKS INSTALLED FOR ONE OMITTED M173 SE-RIES CONTAINER. SIMILAR FILLER BLOCKS CAN BE INSTALLED IN UNIT LOADS CON-TAINING OTHER SERIES CONTAINERS PROVIDED THE CONTAINERS ARE UNITIZED IN A VERTICAL POSITION

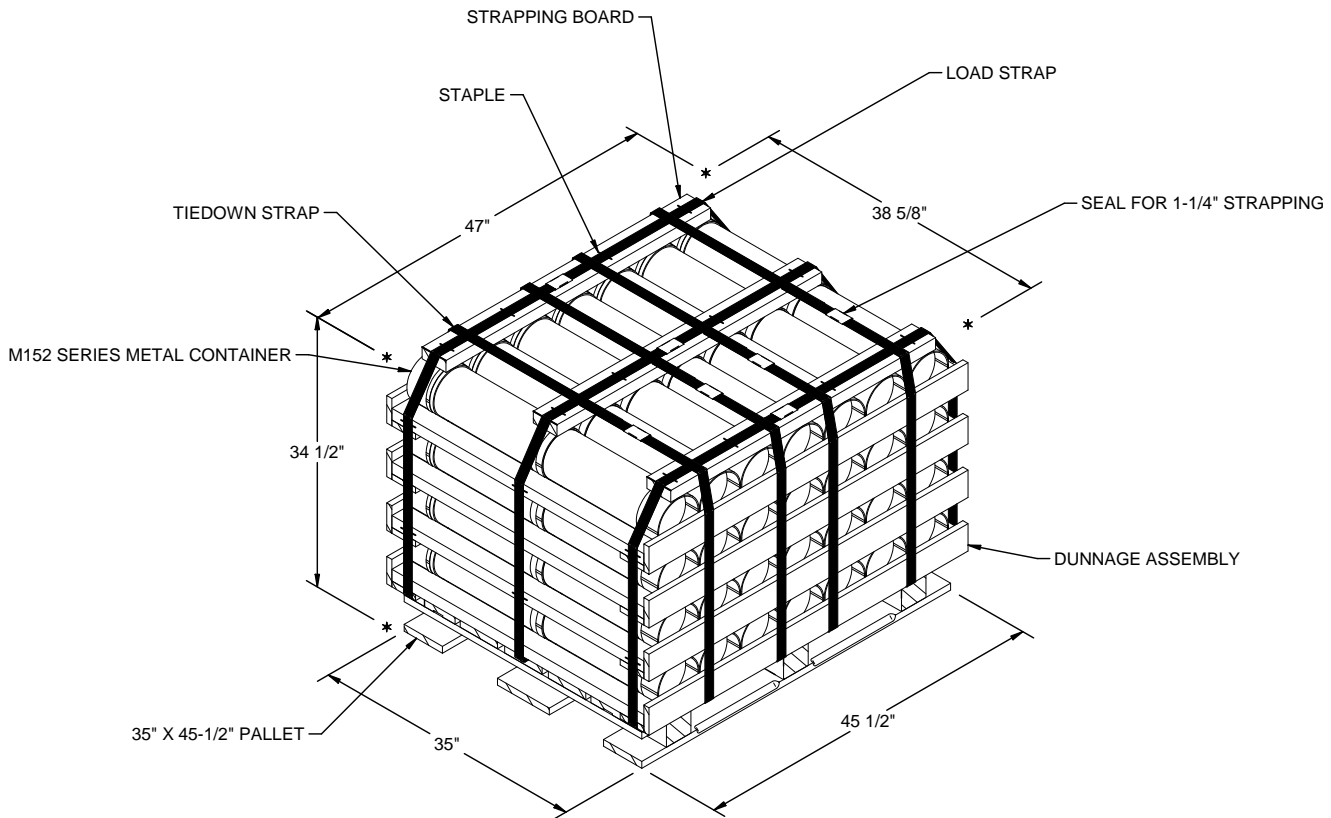

ISOMETRIC VIEW

THE M152 SERIES CONTAINER IS DEPICTED

SPECIAL NOTES:

1. THE UNIT LOAD ABOVE DEPICTS A TYPICAL UNIT LOAD USING FLAT DUNNAGE WITH THE CONTAINERS UNITIZED HORIZONTALLY.
2. EVEN THOUGH ONLY THE M152 SERIES CONTAINER IS DEPICTED ABOVE IN THIS LOAD CONFIGURATION, ANY OTHER SERIES CONTAINER OF A SIMILAR SIZE AND DESIGN MAY BE UNITIZED IN THIS CONFIGURATION. SEE THE APPLICABLE APPENDIX FOR SPECIFIC UNITIZATION PROCEDURAL GUIDANCE.

UNITIZING PROCEDURES

- STEP 1. POSITION PALLET IN DESIRED POSITION, WITH THE TOP DECK BOARDS UPWARDS. POSITION PALLET DUNNAGE ON PALLET AS INDICATED AND NAIL TO THE PALLET DECK BOARDS AS SHOWN. **NOTE:** NAILS MUST NOT BE DRIVEN THROUGH THE STRAP SLOTS OF THE PALLET.
- STEP 2. POSITION THE FIRST LAYER OF CONTAINERS ON THE DUNNAGE ASSEMBLY. POSITION SECOND LAYER DUNNAGE ASSEMBLY ON TOP OF THE FIRST LAYER OF CONTAINERS. REPEAT UNTIL UNIT LOAD IS COMPLETE.
- STEP 3. AFTER PALLET IS LOADED, POSITION STRAPPING BOARDS IN PROPER ALIGNMENT WITH OTHER DUNNAGE ASSEMBLIES. POSITION STRAPPING AROUND UNIT, KEEPING IN VERTICAL ALIGNMENT. SEAL EACH STRAP USING ONE SEAL, WITH TWO PAIR OF NOTCHES PER SEAL. INSTALL STRAP STAPLES AS INDICATED. SEALS SHALL BE PLACED SO AS TO NOT INTERFERE WITH THE STACKING OF ONE UNIT LOAD ON TOP OF ANOTHER.

NOTE: WHEN BUNDLING PALLET UNITS, CARE MUST BE EXERCISED TO INSURE THAT DUNNAGE ASSEMBLIES AND STRAPPING ARE IN VERTICAL ALIGNMENT. WHEN CONTAINERS ARE NOT IN VERTICAL ALIGNMENT, POOR OUTLOADING AND STORAGE PROCEDURES COULD RESULT. SEE GENERAL NOTES "G" AND "U" ON PAGES 2 AND 3 AND "UNIT ASSEMBLY TOLERANCE DETAILS" ON PAGE 10 FOR ALLOWABLE ALIGNMENT TOLERANCES.

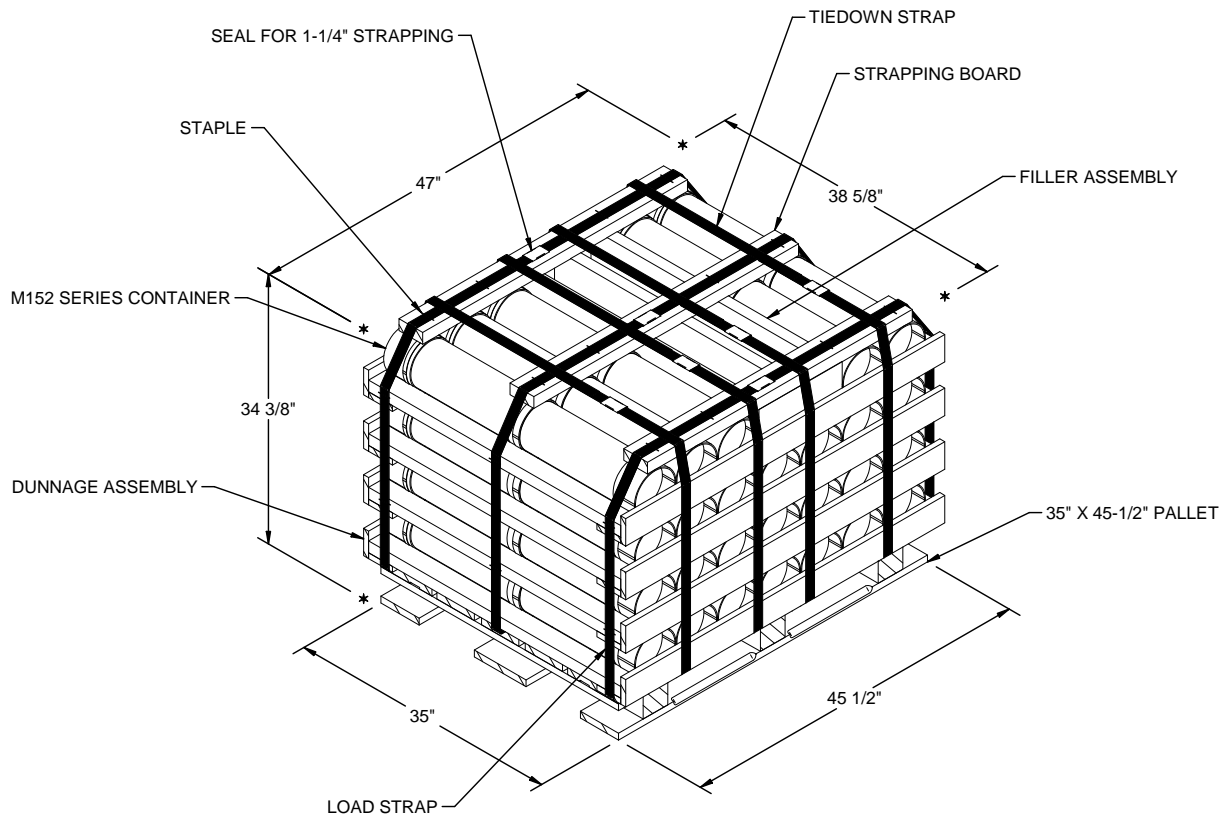

ISOMETRIC VIEW

THE M152 SERIES CONTAINER IS DEPICTED

SPECIAL NOTES:

1. THE UNIT LOAD ABOVE DEPICTS A TYPICAL UNIT LOAD USING FLAT DUNNAGE WITH THE CONTAINERS UNITIZED HORIZONTALLY AND A FILLER ASSEMBLY INSTALLED FOR TWO OMITTED M152 SERIES CONTAINERS. SIMILAR FILLER TYPE ASSEMBLIES CAN BE INSTALLED IN UNIT LOADS CONTAINING OTHER SERIES CONTAINERS. FOR SPECIFIC GUIDANCE IN THE CONSTRUCTION OF A FILLER ASSEMBLY, SEE THE APPLICABLE APPENDIX.
2. GENERALLY, FILLER ASSEMBLIES CAN BE CONSTRUCTED FOR OMITTING ONE, TWO, THREE, FOUR, OR FIVE CONTAINERS, DEPENDING UPON THE LOAD CONFIGURATION. FOR OMITTING MORE THAN FIVE CONTAINERS, A COMBINATION OF FILLERS WILL BE USED. ADDITIONALLY, THE USE OF MORE THAN TWO FILLER ASSEMBLIES PER UNIT LOAD IS NOT PERMITTED.
3. FILLER ASSEMBLIES WILL NOT BE INSTALLED IN THE OUTSIDE STACKS OF A UNIT LOAD. FILLER ASSEMBLIES WILL BE INSTALLED ONLY IN THE TOP LAYER OR LAYERS OF THE CENTER STACK OR STACKS OF A UNIT LOAD.

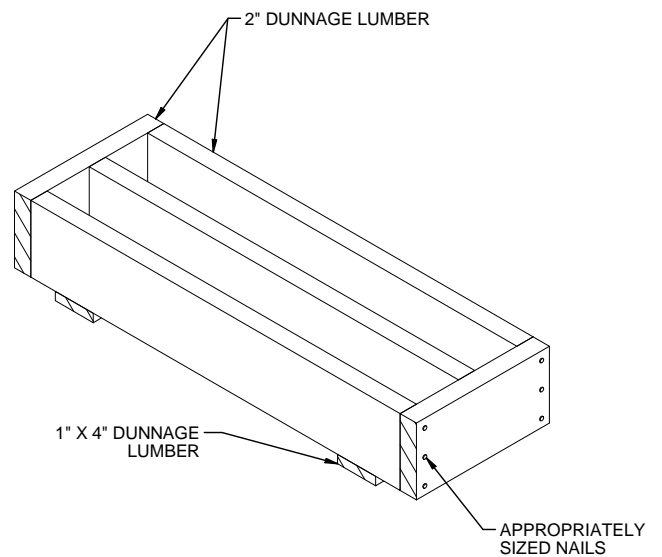

FILLER ASSEMBLY

A FILLER ASSEMBLY FOR TWO OMITTED M152 SERIES CONTAINERS IS DEPICTED

TYPICAL PALLET UNIT WITH FILLER ASSEMBLY FOR OMITTED CONTAINERS

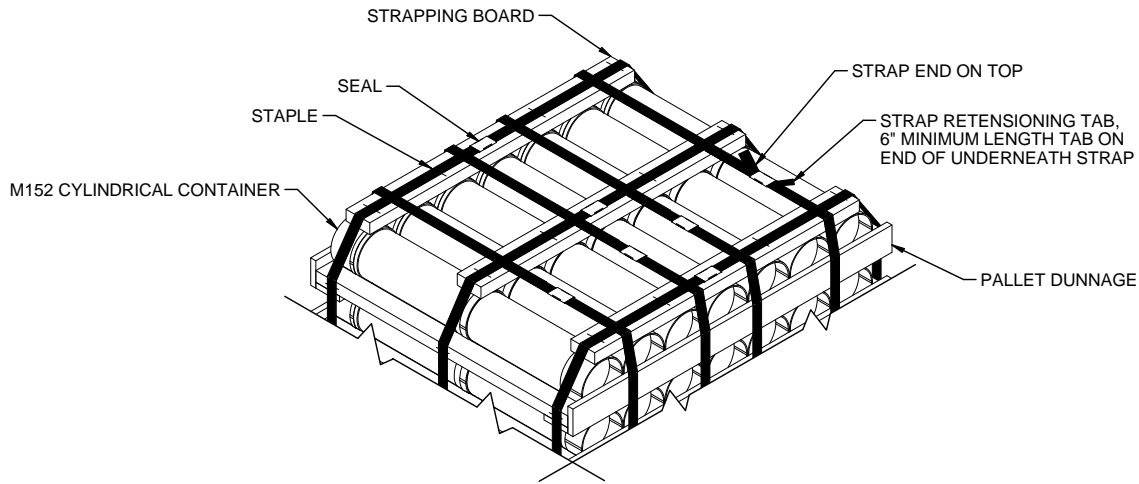

STRAP RETENSIONING TAB

THE M152 SERIES CONTAINER IS DEPICTED (SEE GENERAL NOTE "L" ON PAGE 2.

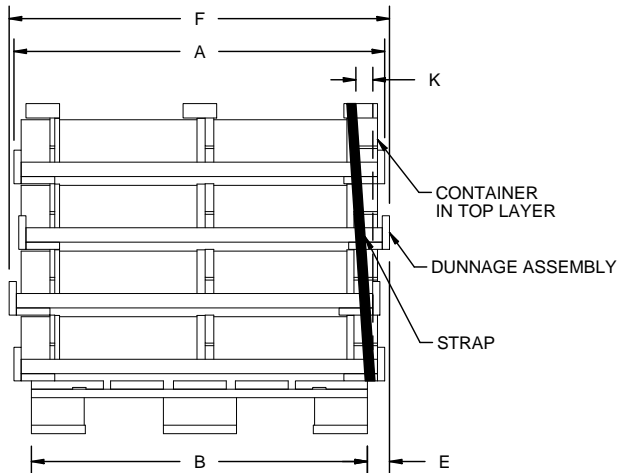

UNIT LENGTH VIEW

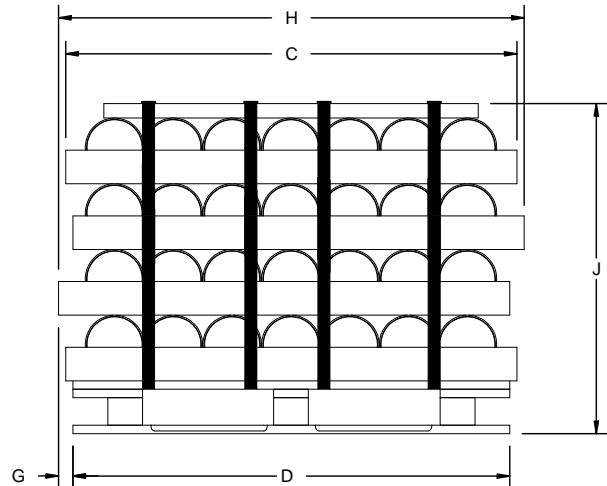

UNIT WIDTH VIEW

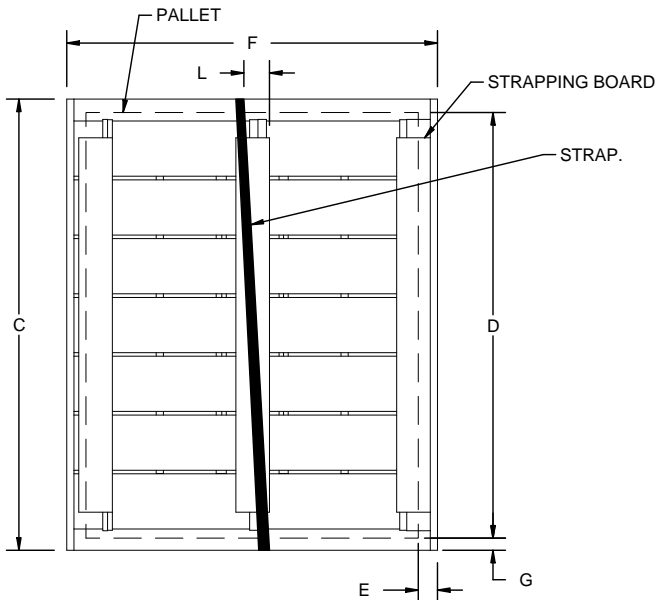

UNIT TOP VIEW

SPECIAL NOTES:

1. DIMENSIONS APPLICABLE TO ALLOWABLE TOLERANCES ARE EXPRESSED IN INCHES AND IDENTIFIED BY LETTERS AS FOLLOWS:
 A = UNIT LENGTH
 B = PALLET LENGTH
 C = UNIT WIDTH
 D = PALLET WIDTH
 E = (A-B)/2 WITH A PLUS OR MINUS 1/2" TOLERANCE FOR EACH LAYER AND FOR EACH STACK = LENGTHWISE OVERHANG
 F = DIMENSION "A" PLUS 1/2" MAXIMUM = ALLOWABLE UNIT LENGTH
 G = (C-D)/2 WITH A PLUS OR MINUS 1/2" TOLERANCE FOR EACH LAYER = WIDTHWISE OVERHANG
 H = DIMENSION "C" PLUS 1/2" MAXIMUM = ALLOWABLE UNIT WIDTH
 J = UNIT HEIGHT
 K = J/24" = MAXIMUM INCHES FROM TRUE ALIGNMENT (E.G., IF J = 36", K = 36"/24" = 1-1/2" MAXIMUM) = VERTICAL STRAP ALIGNMENT
 L = C/24" = MAXIMUM INCHES FROM TRUE ALIGNMENT (E.G., IF C = 48", L = 48"/24" = 2" MAXIMUM) = TRANSVERSE STRAP ALIGNMENT
2. CONTAINER, DUNNAGE ASSEMBLY, AND PIECE ALIGNMENT TOLERANCES APPLY TO EACH LAYER AND TO EACH STACK RELATIVE TO THE PALLET DECK. SEE GENERAL NOTES "G" AND "U" ON PAGES 2 AND 3.
3. STRAPPING TOLERANCES APPLY TO ALL STRAPS AND TO ALL SURFACES WHICH EACH STRAP ENCOMPASSES; I.E., TOP, BOTTOM AND BOTH SIDES.
4. ALTHOUGH THE DIMENSIONS APPLICABLE TO ALLOWABLE TOLERANCES SPECIFIED IN SPECIAL NOTE 1 ABOVE AND DEPICTED IN THE DETAIL ON THIS PAGE ARE FOR UNITS HAVING THE CONTAINERS UNITIZED HORIZONTALLY, THE GUIDANCE PROVIDED IS ALSO APPLICABLE TO UNITS HAVING THE CONTAINERS UNITIZED VERTICALLY.

UNIT ASSEMBLY TOLERANCE DETAILS