

APPROVED BY  
 BUREAU OF EXPLOSIVES  
*M. R. Miller*  
 SUPERVISOR, MILITARY & INTERMODAL SERVICES  
 DATE *4/9/81*

# LOADING AND BRACING (CL & LCL) IN BOX CARS OF PALLETIZED PROPELLING CHARGES PACKED IN CYLINDRICAL METAL CONTAINERS MIO SERIES CONTAINER

INDEX

<u>ITEM</u>	<u>PAGE (S)</u>
GENERAL NOTES -----	2, 3
MATERIAL SPECIFICATIONS -----	2
PALLET UNIT DETAILS -----	4, 5
ALTERNATED CONTAINERS UNITS ( BASIC HEIGHT ):	
LOADS -----	6-15
DETAILS -----	16-19
ALTERNATED CONTAINERS UNITS ( INCREASED HEIGHT ):	
LOADS -----	20-29
DETAILS -----	30-33
FLAT DUNNAGE METHOD UNITS ( BASIC HEIGHT ):	
LOADS -----	34-43
DETAILS -----	44-47
FLAT DUNNAGE METHOD UNITS ( DECREASED HEIGHT ):	
LOADS -----	48-57
DETAILS -----	58-61
ROUTED DUNNAGE METHOD UNITS ( BASIC HEIGHT ):	
LOADS -----	62-71
DETAILS -----	72-75
ROUTED DUNNAGE METHOD UNITS ( DECREASED HEIGHT ):	
LOADS -----	76-85
DETAILS -----	86-89
LCL PROCEDURES FOR CARS EQUIPPED WITH MECHANICAL BRACING DEVICES -----	90, 91
LCL PROCEDURES FOR CONVENTIONAL BOX CARS -----	92-120
GENERAL DETAILS -----	121-128
PROVISIONS FOR BOX CARS EQUIPPED WITH LOAD DIVIDER BULKHEADS -----	129, 130

THIS OUTLOADING PROCEDURE DRAWING INCLUDES PROCEDURES FOR CONVENTIONAL TYPE BOX CARS, BOX CARS EQUIPPED WITH MECHANICAL BRACING DEVICES OF VARIOUS DESIGN AND MANUFACTURE, AND CUSHIONED BOX CARS EQUIPPED WITH LOAD DIVIDER BULKHEADS.

THIS DRAWING SUPERSEDES THE CARLOADING PORTIONS DELINEATED ON PAGES 42 THRU 73 OF DRAWING 19-48-4042-1-2-5-11-14PM1000, DATED 8 FEBRUARY 1965 AND REVISION 1, DATED 29 AUGUST 1969.

**DO NOT SCALE**

REVISIONS				DATE	BY	FOR
				20/81	RSH	RHA/NIUS
				/RSH	/RSH	/RSH
APPROVED, U. S. ARMY ARMAMENT MATERIAL READINESS COMMAND				<i>John M. ...</i>		
APPROVED BY ORDER OF COMMANDING GENERAL, U. S. ARMY MATERIAL DEVELOPMENT AND READINESS COMMAND (MARCOS)				<i>David E. Brown</i>		
U. S. ARMY DARCOM DRAWING				MAY 1981		
CLASS	DIVISION	DRAWING	FILE			
19	48	4042B/ 1	5PM 1000			

## GENERAL NOTES

- A. THIS DOCUMENT HAS BEEN PREPARED AND ISSUED IN ACCORDANCE WITH AR 740-1 AND AUGMENTS TM 743-200-1 (CHAPTER 5).
- B. THE UNLOADING PROCEDURES SPECIFIED IN THIS DRAWING ARE APPLICABLE FOR THE M10 SERIES PROPELLING CHARGE CONTAINER WHEN UNITIZED ON A 40" X 48" PALLET. SEE THE PICTORIAL VIEWS ON PAGES 4 AND 5. REFER TO THE US ARMY DARCOM DRAWING 19-48-4042A/1-20PM1001 FOR UNITIZATION PROCEDURES FOR THE M10 SERIES CONTAINER.
- C. THE UNLOADING PROCEDURES DEPICTED WITHIN THIS DOCUMENT ARE APPLICABLE FOR SHIPMENTS IN CONVENTIONAL TYPE BOX CARS, FOR SHIPMENTS IN BOX CARS EQUIPPED WITH VARIOUS TYPES OF SELF-CONTAINED MECHANICAL BRACING DEVICES, AND FOR SHIPMENTS IN CUSHIONED BOX CARS EQUIPPED WITH LOAD DIVIDER BULKHEADS.
- D. CAUTION: METAL PROPELLING CHARGE CONTAINERS THAT OVERHANG THE PALLET END MUST NOT BE ALLOWED TO CONTACT STEEL SIDEWALLS OR END WALLS OF BOX CARS. THIS TYPE OF UNIT LOAD SHOULD BE SHIPPED IN BOX CARS HAVING WOOD SIDEWALLS AND/OR END WALLS. IF CARS WITH WOOD SIDEWALLS AND/OR END WALLS ARE NOT AVAILABLE, AND ALL-STEEL CARS ARE USED, THE SIDEWALLS AND/OR END WALLS MUST BE LINED WITH DIMENSIONAL LUMBER, PLYWOOD, HARDBOARD, OR SOLID FIBERBOARD. THE LINING SHOULD BE PROVIDED WHEREVER METAL-OF-CONTAINER TO METAL-OF-CAR CONTACT IS POSSIBLE. REFER TO PAGE 121 FOR GUIDANCE.
- E. EXCEPT FOR PALLET UNITS OF ALTERNATED CONTAINERS, UNITS WILL BE POSITIONED WITH THE BASE ENDS OF CONTAINERS AGAINST THE CAR END WALL OR SIDEWALL AS APPLICABLE TO THE LOAD BEING SHIPPED. LONGITUDINALLY ADJACENT LENGTHWISE UNITS WILL BE POSITIONED WITH BASE END AGAINST BASE END OR BELL END AGAINST BELL END, EXCEPT FOR UNITS HAVING ALTERNATED CONTAINERS.
- F. THE SELECTION OF RAIL CARS FOR THE TRANSPORT OF PALLETIZED UNITS OF PROPELLING CHARGES IS THE RESPONSIBILITY OF THE ORIGINATING CARRIER AND THE SHIPPER. ONLY CARS WHICH HAVE "SOUND" FLOORS AND ARE IN OTHERWISE PROPER CONDITION, IN ACCORDANCE WITH THE REQUIREMENTS OF THE APPLICABLE REGULATORY DOCUMENTS, WILL BE SELECTED.
- G. WHEN SELECTING RAIL CARS, EVERY EFFORT SHOULD BE MADE TO OBTAIN BOX CARS THAT DO NOT HAVE BOWED END WALLS. CARS HAVING BOWED ENDS CAN BE USED, HOWEVER, IF AN END WALL IS BOWED OUTWARD MORE THAN TWO INCHES (2"), EITHER FROM SIDE TO SIDE OR FROM FLOOR TO ROOF, AN END-OF-CAR BULKHEAD MUST BE INSTALLED TO PROVIDE A "SQUARED OFF" SURFACE FOR THE LOAD AT THE END OF THE CAR. REFER TO PAGE 122 FOR GUIDANCE.
- H. BOX CARS EQUIPPED WITH CONVENTIONAL SLIDING DOORS HAVE BEEN SHOWN. HOWEVER, THE DEPICTED UNLOADING PROCEDURES ARE ALSO APPLICABLE FOR CARS EQUIPPED WITH PLUG DOORS. CAUTION: DUNNAGE MATERIAL MUST NOT BE NAILED TO ANY PLUG DOOR, WHETHER AUXILIARY OR MAIN. ALSO, AFTER THE PLUG DOORS ON A CAR ARE CLOSED AND READY FOR THE INSTALLATION OF CAR SEALS, A PIECE OF WIRE OF SUITABLE SIZE WILL BE USED IN ADDITION TO, AND IN CONJUNCTION WITH EACH CAR SEAL USED TO SEAL THE CAR. THE WIRE WILL BE THREADED THRU THE HOLES IN THE DOOR LATCH ASSEMBLY ONE OR MORE TIMES, AND THE WIRE ENDS WILL BE TWISTED TOGETHER.
- J. THE USE OF AN OFFSET LOADING PATTERN WILL FACILITATE LOADING AND UNLOADING OPERATIONS IN THE DOORWAY AREA OF THE CAR. WHEN POSSIBLE TO DO SO, A FULL LOAD SHOULD BE BUILT USING AN OFFSET LOADING PATTERN. FOR INSTANCE, A LOAD CONSISTING OF AN EVEN NUMBER OF LOAD UNITS AND HAVING TWO MORE LOAD UNITS IN ONE END OF THE CAR THAN IN THE OPPOSITE END, OR A LOAD CONSISTING OF AN ODD NUMBER OF LOAD UNITS AND HAVING ONE MORE LOAD UNIT IN ONE END THAN IN THE OTHER IS CONSIDERED TO BE AN OFFSET LOAD.
- K. OTHER TYPES OF LADING ITEMS MAY BE LOADED IN CARS WHICH ARE PARTIALLY LOADED WITH PALLETIZED UNITS OF PROPELLING CHARGES, PROVIDING THE TOTAL LOAD IS COMPATIBLE, EXISTING DIRECTIVES ARE NOT VIOLATED, AND THE OTHER LADING ITEMS ARE BLOCKED AND BRACED TO EQUAL THE BLOCKING AND BRACING CRITERIA SPECIFIED HEREIN. MIXED ITEMS TO BE SHIPPED IN CARS EQUIPPED WITH MECHANICAL BRACING DEVICES MUST BE SEPARATELY BLOCKED, USING THE PROCEDURES SHOWN FOR THESE CARS AS GUIDANCE.

(CONTINUED AT RIGHT)

### MATERIAL SPECIFICATIONS

LUMBER	SEE TM 743-200-1, DUNNAGE LUMBER, FED SPEC MM-L-751.
NAILS	COMMON, FED SPEC FF-N-105.
STRAPPING, STEEL	CLASS I, TYPE I OR IV, HEAVY DUTY, FINISH A OR B (GRADE 2), FED SPEC QQ-5-781.
STRAP SEAL	TYPE D, STYLE I, II, OR IV, CLASS H, FED SPEC QQ-5-781.
STRAP STAPLE	COMMERCIAL GRADE.
PLYWOOD	GROUP B OR C, GRADE C-D (EXTERIOR). FED SPEC NN-P-530. IF SPECIFIED GRADE IS NOT AVAILABLE, A BETTER EXTERIOR GRADE MAY BE SUBSTITUTED.
WIRE	FED SPEC QQ-W-461.
HARDBOARD	FED SPEC LL-B-810.
SOLID FIBERBOARD	FED SPEC PP-F-320. TYPE SF, CLASS DOMESTIC, GRADE 175 OR STRONGER; OR TYPE SF, CLASS WEATHER-RESISTANT, GRADE W65 OR STRONGER.

## (GENERAL NOTES CONTINUED)

- L. DUNNAGE LUMBER SPECIFIED THROUGHOUT THIS PROCEDURAL DRAWING IS OF NOMINAL SIZE. FOR EXAMPLE 2" X 4" MATERIAL IS ACTUALLY 1-1/2" THICK BY 3-1/2" WIDE AND 2" X 6" MATERIAL IS ACTUALLY 1-1/2" THICK BY 5-1/2" WIDE. IF THOSE MEMBERS SPECIFICALLY IDENTIFIED AS "STRUTS" WITHIN THE KEY NUMBERS OF A DEPICTED LOAD ARE SPECIFIED TO BE 4" X 4" MATERIAL, IT IS PERMISSIBLE TO USE TWO LAMINATED PIECES OF 2" X 6" MATERIAL IN LIEU OF EACH 4" X 4" STRUT. DOUBLED 2" X 6" STRUTS WILL BE LAMINATED W/1-10d NAIL EVERY 6".
- M. NOTICE: A STAGGERED NAILING PATTERN WILL BE USED WHEREVER POSSIBLE WHEN NAILS ARE DRIVEN INTO JOINTS OF DUNNAGE ASSEMBLIES. ALSO, A STAGGERED NAILING PATTERN WILL BE USED WHEN DUNNAGE IS NAILED TO THE FLOOR OR SIDEWALL OF THE TRANSPORTING VEHICLE, OR WHEN LAMINATING DUNNAGE. THE NAILING PATTERN WILL BE ADJUSTED AS REQUIRED SO THAT A NAIL DOES NOT PENETRATE INTO OR NEAR A CRACK BETWEEN FLOOR BOARDS OR SIDEWALL BOARDS. ADDITIONALLY, THE NAILING PATTERN FOR AN UPPER PIECE OF LAMINATED DUNNAGE WILL BE ADJUSTED AS REQUIRED SO THAT A NAIL FOR THAT PIECE WILL NOT BE DRIVEN THROUGH ONTO OR RIGHT BESIDE A NAIL IN A LOWER PIECE.
- N. WHEN STEEL STRAPPING IS SEALED AT AN END-OVER-END LAP JOINT, A MINIMUM OF TWO (2) SEALS, BUTTED TOGETHER, WITH TWO (2) PAIR OF CRIMPS PER SEAL WILL BE USED TO SEAL THE JOINT.
- O. THROUGHOUT THIS PROCEDURAL DRAWING, PORTIONS OF THE BLOCKING COMPONENTS AND OF THE DEPICTED CARS, SUCH AS A CAR SIDE WALL, HAVE BEEN OMITTED FROM THE LOAD VIEW FOR CLARITY PURPOSES.
- P. THE NUMBER OF LADING UNITS MAY BE ADJUSTED TO FIT THE SIZE OF THE BOX CAR BEING LOADED OR THE QUANTITY TO BE SHIPPED. HOWEVER, THE APPROVED METHODS SPECIFIED HEREIN MUST BE FOLLOWED AS CLOSELY AS POSSIBLE FOR BLOCKING, BRACING, AND STAYING OF THE UNITS. NOTICE: A SHIPMENT WILL BE POSITIONED IN THE RAIL CAR IN COMPLIANCE WITH THE WEIGHT DISTRIBUTION REQUIREMENTS OF THE AAR.

## GENERAL NOTES

(FOR CONVENTIONAL TYPE BOX CARS)

- Q. IF THE CAR BEING USED FOR A SHIPMENT IS EQUIPPED WITH A NAILABLE METAL FLOOR AND A NAIL SIZE FOR FLOOR NAILING IS MARKED ON THE SIDEWALL OF THE CAR, THAT GUIDANCE SHOULD BE APPLIED TO THE NAILING OF THE "DOORWAY BLOCKING" PIECES IN THE FULL LOADS AND TO THE NAILING TO THE CAR FLOOR OF THE LCL BRACES AND KNEE BRACE ASSEMBLIES IN THE LESS-THAN-FULL LOADS. IF A NAIL SIZE IS NOT SPECIFIED IN THE CAR, 30d NAILS SHOULD BE USED IN LIEU OF THOSE SPECIFIED IN THE APPLICABLE KEY NUMBERS. SEE GENERAL NOTE "M" ABOVE.
- R. NOTICE: WHEN POSITIONING PALLETIZED UNITS IN A CAR THEY SHOULD BE PLACED TIGHTLY AGAINST A CAR SIDEWALL AND ARE TO BE PRESSED TIGHTLY TOGETHER LENGTHWISE SO AS TO ACHIEVE A TIGHT LOAD. TO AID IN ACHIEVING TIGHTNESS LENGTHWISE IN A FULL LOAD, A LOAD-COMPRESSING JACK MAY BE EMPLOYED IN THE AREA OF THE CENTER GATES TO MOVE THE PALLETIZED UNITS INTO THEIR FINAL SHIPPING POSITION. A HYDRAULIC JACK IS RECOMMENDED FOR THIS OPERATION. CAUTION: WHEN USING A JACK TO COMPACT A LOAD, THE JACK MUST BE USED AGAINST STRONG POINTS OF THE PALLETIZED UNITS, SUCH AS THE JOINTS BETWEEN THE LAYERS OF CONTAINERS ON THE UNIT. PADDING, OF 2-INCH (2") THICK LUMBER OR ANY OTHER MATERIAL OF SIMILAR CONSISTENCY, SHOULD BE PLACED BETWEEN THE JACK AND THE LADING.
- S. LOAD-BLOCKING STRUTS WHICH ARE 48" OR LONGER MUST BE STIFFENED BY THE APPLICATION OF HORIZONTAL AND VERTICAL STRUT BRACING AS SHOWN BY THE "STRUT BRACING" DETAIL ON PAGE 124. BRACING IS NOT REQUIRED IF THE STRUTS FOR THE LOAD BEING SHIPPED ARE SHORTER THAN 48". THE LENGTH OF THE LOAD-BLOCKING STRUTS SHOULD BE KEPT AS SHORT AS POSSIBLE (APPROX 18" MINIMUM), BUT IN THE EVENT IT IS NECESSARY TO USE STRUTS WHICH ARE 8'-0" OR MORE IN LENGTH, IT WILL BE NECESSARY TO APPLY AN ADDITIONAL SET OF HORIZONTAL AND VERTICAL STRUT BRACING PIECES. STRUT BRACING SHOULD BE APPLIED SO AS TO PROVIDE NEARLY EQUAL SPACES BETWEEN THE BRACING PIECES AND THE CENTER GATES AND/OR BETWEEN ADJACENT STRUT BRACING PIECES. NOTE THAT HORIZONTAL STRUT BRACING PIECES FOR THE UPPER LEVEL OF STRUTS FOR ALL BUT THE UPPERMOST TIER OF A LOAD MAY BE DIFFICULT TO APPLY TO THE TOP SURFACES OF THE STRUTS AS DEPICTED. STRUT BRACING WILL BE EQUALLY EFFECTIVE IF APPLIED TO THE UNDER SIDE OF THOSE STRUTS.
- T. TO ACHIEVE A TIGHTLY BLOCKED LOAD, A STRUT WILL BE CUT SLIGHTLY LONGER THAN THE MEASURED DISTANCE BETWEEN THE STRUT BEARING AREAS ON THE TWO CENTER GATES. ONE END OF THE STRUT WILL BE POSITIONED AT ITS BEARING AREA JUST ABOVE THE STRUT LEDGER ON ONE GATE. THE OTHER END, WHICH CAN BE BEVELED ON THE LOWER CORNER IF DESIRED, WILL THEN BE DRIVEN DOWNWARD UNTIL IT CONTACTS THE STRUT LEDGER ON THE OTHER GATE. EACH END OF THE STRUT WILL BE TOENAILED TO THE ADJACENT CENTER GATE, AS SPECIFIED WITHIN THE KEY NUMBERS FOR A LOAD, IN SUCH A MANNER SO THAT AS NEARLY AS PRACTICAL EQUAL LENGTHS OF A NAIL ARE EMBEDDED IN THE STRUT AND IN THE VERTICAL PIECE OF THE CENTER GATE. SEE THE "BEVEL CUT" DETAIL ON PAGE 124 FOR BEVELING INSTRUCTIONS AND THE "STRUT INSTALLATION" DETAIL ON THAT PAGE FOR A PICTORIAL VIEW SHOWING THE PROPER POSITIONING OF A BEVELED STRUT FOR INSTALLATION. NOTE THAT THE UPPER CORNER NEEDS TO BE BEVELED ONLY IF THE STRUTS ARE VERY SHORT. IF ONLY ONE END IS BEVEL-CUT, THE BEVELED EDGE WILL BE PLACED IN THE DOWNWARD POSITION SO THAT IT WILL ALLOW THE STRUT END TO SLIDE MORE FREELY DOWN THE FACE OF THE VERTICAL PIECE ON THE ADJACENT CENTER GATE AS THE STRUT IS DRIVEN DOWN INTO ITS FINAL BLOCKING POSITION.
- U. FOR ADDITIONAL GUIDANCE, ATTENTION IS DIRECTED TO THE "SPECIAL NOTES" SECTIONS WHICH ARE IMMEDIATELY ADJACENT TO THE DEPICTED UNLOADING METHODS.

### GENERAL NOTES

(FOR BOX CARS EQUIPPED WITH MECHANICAL BRACING DEVICES)

- W. THE OUTLOADING PROCEDURES FOR BOX CARS EQUIPPED WITH MECHANICAL BRACING DEVICES MAY BE ADAPTED AS REQUIRED TO FACILITATE THE USE OF BOX CARS EQUIPPED WITH VARIOUS TYPES OF SELF-CONTAINED MECHANICAL BRACING DEVICES. HOWEVER, FIXED OR ADJUSTABLE WALL MEMBERS AND DOORWAY MEMBERS WITHIN THESE CARS MUST PROVIDE FOR THE INSTALLATION OF LOAD BLOCKING CROSS MEMBERS AT THE HEIGHTS SPECIFIED. CAUTION: BOX CARS EQUIPPED WITH MEMBERS WHICH DO NOT MEET THE LOCATION REQUIREMENTS MUST NOT BE USED.
1. FOR BLOCKING THE LOADS WHICH ARE DEPICTED, A CROSS MEMBER WILL NOT BE RELIED UPON TO RETAIN MORE LADING ON EITHER SIDE THAN AS SHOWN. VOIDS LENGTHWISE WITHIN THE LOAD MUST BE HELD TO A MINIMUM AND CROSS MEMBERS MUST BE PLACED AGAINST THE LADING AS TIGHTLY AS THE SPACING OF THE LOCKING HOLES IN THE WALL MEMBERS PERMIT. LOCKING BARS (LEVER JACKS) SHOULD BE USED FOR THIS PURPOSE. AN ADDITIONAL 1/2" OF ADJUSTMENT CAN BE MADE BY TURNING A CROSS MEMBER END-FOR-END WHEN LOCKING PINS ON THE MEMBER ARE OFF-CENTER. NOTE: IT IS RECOMMENDED THAT EACH CROSS MEMBER BE INSTALLED WITH THE ENDS ATTACHED AS NEARLY AS POSSIBLE IN "MATED" POSITIONS (AT EQUAL HEIGHTS AND AT EQUAL DISTANCES FROM THE END OF THE CAR).
  2. CAUTION: ALL BLOCKING AND BRACING COMPONENTS IN EMPTY CARS AND ALL UNUSED COMPONENTS IN LOADED CARS MUST BE "SECURED" FOR SHIPMENT---ADJUSTABLE WALL MEMBERS TO VERTICAL WALL ATTACHMENT RAILS, AND CROSS MEMBERS TO ADJUSTABLE WALL MEMBERS OR TO FIXED HORIZONTAL WALL MEMBERS OR TO DOORWAY MEMBERS, AND DOORWAY MEMBERS TO DOOR POSTS. COMPONENTS ASSIGNED TO EACH CAR MUST REMAIN THEREWITH EVEN THOUGH UNUSED DURING SOME SHIPMENTS.
- X. IN A CAR EQUIPPED WITH ADJUSTABLE WALL MEMBERS, PROVIDING THE FIXED WALL MEMBERS WHICH ARE PRESENT IN SOME "ADJUSTABLE" CARS ARE NOT PROPERLY POSITIONED TO PROVIDE SIDE BEARING SURFACES BETWEEN THE UNITS AND THE CAR SIDEWALLS, ADJUSTABLE WALL MEMBERS (AS REQUIRED) MUST BE INSTALLED TO PROVIDE A MINIMUM OF ONE SURFACE AREA FOR SIDE BEARING AT SOME LOCATION WITHIN THE UPPER HALF OF EACH UNIT.
- Y. FOR ADDITIONAL GUIDANCE, ATTENTION IS DIRECTED TO THE "SPECIAL NOTES" SECTIONS WHICH ARE IMMEDIATELY ADJACENT TO THE DEPICTED OUTLOADING METHODS.

### GENERAL NOTES

(FOR CARS EQUIPPED WITH LOAD DIVIDER BULKHEADS)

- AA. CAUTION: FOR CUSHIONED BOX CARS EQUIPPED WITH LOAD DIVIDER BULKHEADS, ONLY CARS EQUIPPED WITH LOAD DIVIDERS MANUFACTURED BY EVANS, EQUIPCO, OR PRECO MAY BE USED. LOAD DIVIDERS MANUFACTURED BY TRANSCO ARE NOT ACCEPTABLE, WHETHER OF ALUMINUM OR STEEL CONSTRUCTION. THE DEPICTED PROCEDURES ARE APPLICABLE FOR CARS OF VARIOUS LENGTHS AND WIDTHS. THE AAR MECHANICAL DESIGNATION CLASS FOR THESE CARS, AS IDENTIFIED IN THE "OFFICIAL RAILWAY EQUIPMENT REGISTER," WILL BE RBL, XL, OR XLI.
- BB. THE USE OF LOAD DIVIDER EQUIPPED CARS WILL ELIMINATE THE NEED FOR CENTER GATES AND STRUTS, AND GATE HOLD DOWNS (WHEN APPLICABLE) WHICH ARE REQUIRED IN CONVENTIONAL BOX CAR LOADS. THIS WILL ACCOUNT FOR A CONSIDERABLE SAVING IN MATERIAL AND LABOR COSTS. THEREFORE, EVERY EFFORT SHOULD BE MADE TO ACQUIRE CUSHIONED CARS EQUIPPED WITH LOAD DIVIDERS FOR SHIPMENT OF PROPELLING CHARGES. NOTICE: ONLY CUSHIONED CARS THAT HAVE SLIDING CENTER SILL TYPE CUSHIONING DEVICES OR END-OF-CAR TYPE DEVICES WHICH HAVE AT LEAST FIFTEEN INCHES (15") OF TRAVEL ARE ACCEPTABLE.
- CC. IF NAILING TO A CAR SIDEWALL IS NOT REQUIRED, BOX CARS EQUIPPED WITH ADJUSTABLE SIDE FILLERS THAT HAVE 3/8" OR THICKER PANELS MAY BE USED. HOWEVER, THESE SIDE FILLERS MUST NOT BE USED FOR LATERAL BLOCKING; THEY MUST BE RETRACTED AND LOCKED AGAINST THE CAR SIDEWALL. A "FILL PIECE" MUST BE INSTALLED IN THE VOID BETWEEN THE CAR SIDEWALL AND THE SIDE FILLER PANEL. SEE THE "TYPICAL TYPE A" VIEW ON PAGE 130 FOR GUIDANCE. IF THE BACK OF THE SIDE FILLER PANELS ARE REINFORCED WITH VERTICAL AND HORIZONTAL STEEL MEMBERS AS SHOWN IN THE "TYPICAL TYPE B" VIEW ON PAGE 130, THE "FILL PIECE" MATERIAL IS NOT REQUIRED.
- DD. NOTICE: AFTER THE LOAD DIVIDER BULKHEADS ARE POSITIONED AGAINST THE LADING, AND THE LOCKING PINS ARE ENGAGED IN THE HOLES OF THE RAILS, THE LOWER LOCKING PINS MUST BE INSPECTED TO ENSURE THAT THE PINS ARE FULLY ENGAGED IN THE LOCKING HOLES. IF THE PINS ARE NOT FULLY SEATED IN THE LOCKING HOLES, THE LINKAGE MECHANISM WILL BE ADJUSTED AS REQUIRED SO THAT THE PINS WILL BE FULLY SEATED INTO THE LOCKING HOLES OF THE LOWER RAILS. IF PRESENT, DEBRIS MUST BE REMOVED FROM BENEATH THE LOCKING HOLES WHICH HAVE BEEN SELECTED FOR SECURING A LOAD DIVIDER BULKHEAD.
- EE. A "STRUT ASSEMBLY" MUST BE INSTALLED BETWEEN THE LOAD DIVIDER BULKHEADS IF THE CAR CONTAINS CLASS A OR CLASS B EXPLOSIVES AND THE LOAD IN EITHER END OF THE CAR WEIGHS 50,000 POUNDS OR MORE. A STRUT ASSEMBLY IS NOT REQUIRED FOR LOADS OF CLASS C EXPLOSIVES. NOTE THAT THE STRUT ASSEMBLY MAY BE OMITTED FROM LOADS OF CLASS A OR B EXPLOSIVES WEIGHING 50,000 POUNDS WHEN THE LADING AND ADEQUATE BLOCKING AND BRACING ARE POSITIONED TO COMPLETELY FILL THE SPACE BETWEEN THE INSTALLED BULKHEADS AS SPECIFIED IN GENERAL NOTE "FF-3" AT RIGHT. DETAILS OF STRUT ASSEMBLIES FOR USE BETWEEN 2-PIECE BULKHEADS AND BETWEEN 1-PIECE BULKHEADS ARE SHOWN ON PAGE 129.

(CONTINUED AT RIGHT)

### (GENERAL NOTES CONTINUED)

- FF. THE NORMAL LOADING PATTERN IN CARS EQUIPPED WITH LOAD DIVIDER BULKHEADS IS TO POSITION THE LADING BETWEEN A CAR END WALL AND A LOAD DIVIDER BULKHEAD IN FULL LAYERS. OBVIOUSLY, A LOAD QUANTITY MUST THEN BE A MULTIPLE OF THE NUMBER OF PALLETIZED UNITS WHICH ARE IN ONE LOAD UNIT. A LOAD UNIT IS DEFINED AS A STACK OF CONTAINERS WHICH IS FULL CAR WIDTH BY FULL LOAD HEIGHT BY ONE UNIT IN LENGTH. IF THE QUANTITY TO BE SHIPPED CANNOT BE ATTAINED BY ADJUSTING THE NUMBER OF TIERS IN ONE OR BOTH ENDS OF A CAR, OR BY ADJUSTING THE NUMBER OF LOAD UNITS IN EITHER END OF THE CAR, ONE OF THE FOLLOWING PROCEDURES MUST BE USED IN ORDER TO OBTAIN THE DESIRED QUANTITY.
1. ONE OR MORE RISERS CAN BE POSITIONED WITHIN A LOAD TO INCREASE A LOAD QUANTITY. SEE THE RISER PROCEDURES AND DETAILS ON PAGE 102 THRU 105.
  2. THE "GATES AND STRUTS" METHOD OF OMITTING A PALLET UNIT MAY BE USED TO ADJUST A LOAD QUANTITY DOWNWARD BY OTHER THAN A MULTIPLE OF A LOAD UNIT. SEE THE PROCEDURES ON PAGES 96 THRU 101 FOR GUIDANCE.
  3. AT LOCATION (5) WHERE K-BRACES MIGHT NORMALLY BE USED IN A LOAD IN A CONVENTIONAL CAR, LOAD DIVIDER BULKHEADS CAN BE POSITIONED. LOADING CAN THEN CONTINUE TOWARD THE CENTER OF THE CAR FROM EACH INSTALLED LOAD DIVIDER BULKHEAD, IN EVEN LAYERS WHICH ARE ONE OR MORE LESS IN HEIGHT THAN THE LOAD IN THE ENDS OF THE CAR. INSTALL CENTER GATES, STRUTS AND GATE HOLD DOWNS AS SHOWN IN THE APPLICABLE CONVENTIONAL BOX CAR DRAWING HEREIN, TO PROVIDE FOR A TIGHT LOAD BETWEEN THE BULKHEADS.
  4. ONE OR MORE UNITS CAN BE POSITIONED IN CONTACT WITH A LOAD DIVIDER BULKHEAD ON THE CENTER-OF-CAR SIDE. BLOCK AND BRACE WITH LCL BRACES AS SHOWN ON PAGE 116, OR WITH KNEE BRACE ASSEMBLIES, AS SHOWN ON PAGE 112.
- GG. FOR ADDITIONAL GUIDANCE, ATTENTION IS DIRECTED TO THE "SPECIAL NOTES" SECTIONS WHICH ARE IMMEDIATELY ADJACENT TO THE DEPICTED OUTLOADING METHODS.

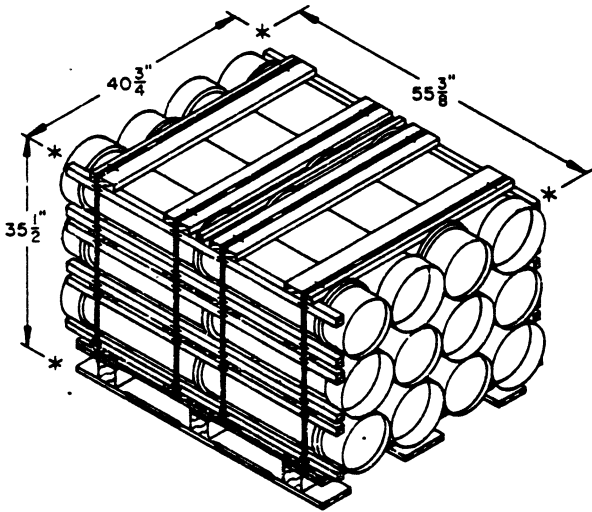

**ALTERNATED CONTAINERS UNIT ( BASIC HEIGHT )**

CONTAINER ----- 12 EACH @ 121 LBS ( APPROX )  
 CUBE ----- 46.4 CUBIC FEET ( APPROX )  
 GROSS WEIGHT ----- 1,636 LBS ( MAX ) ( APPROX )

REFER TO PAGES 6 THRU 15 FOR OUTLOADING PROCEDURES.

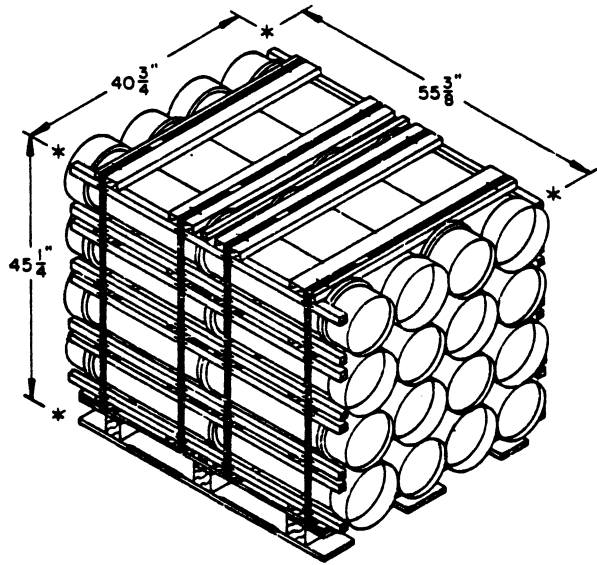

**ALTERNATED CONTAINERS UNIT ( INCREASED HEIGHT )**

CONTAINER ----- 16 EACH @ 121 LBS ( APPROX )  
 CUBE ----- 59.1 CUBIC FEET ( APPROX )  
 GROSS WEIGHT ----- 2,148 LBS ( APPROX )

REFER TO PAGES 20 THRU 29 FOR OUTLOADING PROCEDURES.

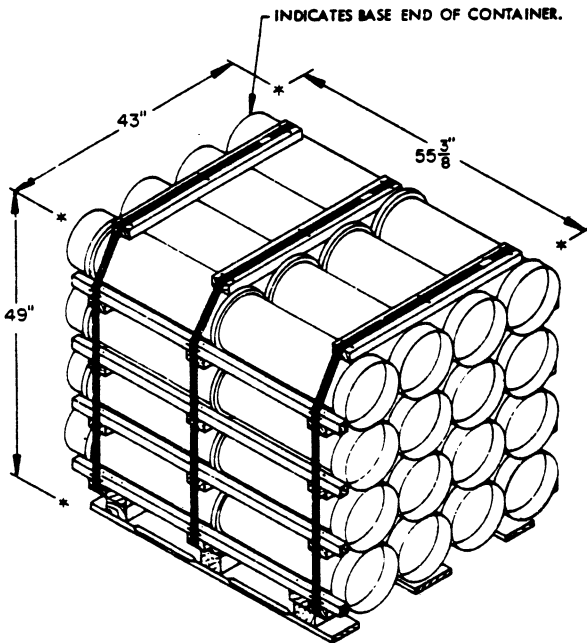

**FLAT DUNNAGE METHOD UNIT ( BASIC HEIGHT )**

CONTAINER ----- 16 EACH @ 121 LBS ( APPROX )  
 CUBE ----- 67.5 CUBIC FEET ( APPROX )  
 GROSS WEIGHT ----- 2,127 LBS ( APPROX )

REFER TO PAGES 34 THRU 43 FOR OUTLOADING PROCEDURES.

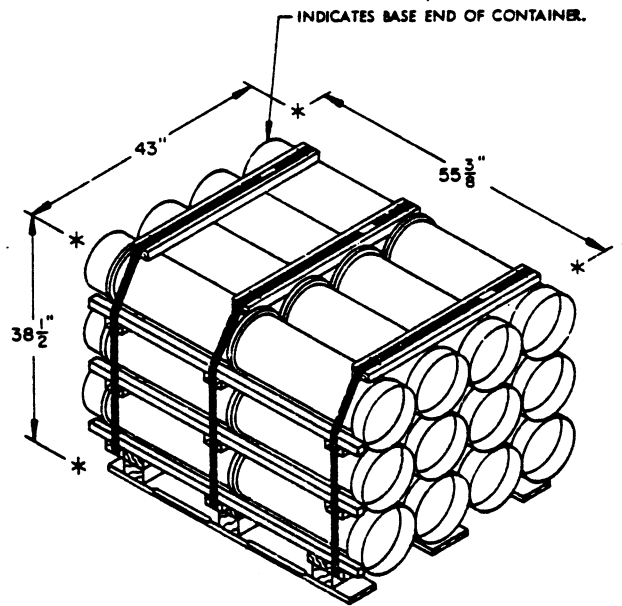

**FLAT DUNNAGE METHOD UNIT ( DECREASED HEIGHT )**

CONTAINER ----- 12 EACH @ 121 LBS ( APPROX )  
 CUBE ----- 53.0 CUBIC FEET ( APPROX )  
 GROSS WEIGHT ----- 1,614 LBS ( APPROX )

REFER TO PAGES 48 THRU 57 FOR OUTLOADING PROCEDURES.

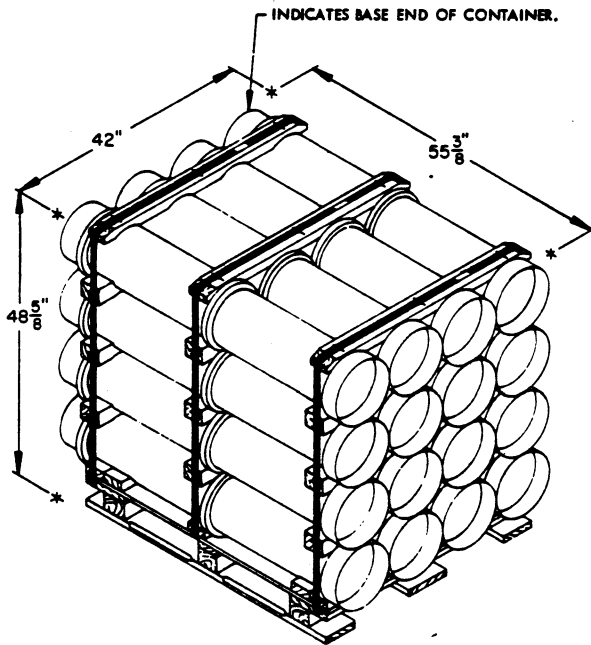

**ROUTED DUNNAGE METHOD UNIT ( BASIC HEIGHT )**

CONTAINER ——— 16 EACH @ 121 LBS ( APPROX )  
 CUBE ——— 65.4 CUBIC FEET ( APPROX )  
 GROSS WEIGHT ——— 2,122 LBS ( APPROX )

REFER TO PAGES 62 THRU 71 FOR OUTLOADING PROCEDURES.

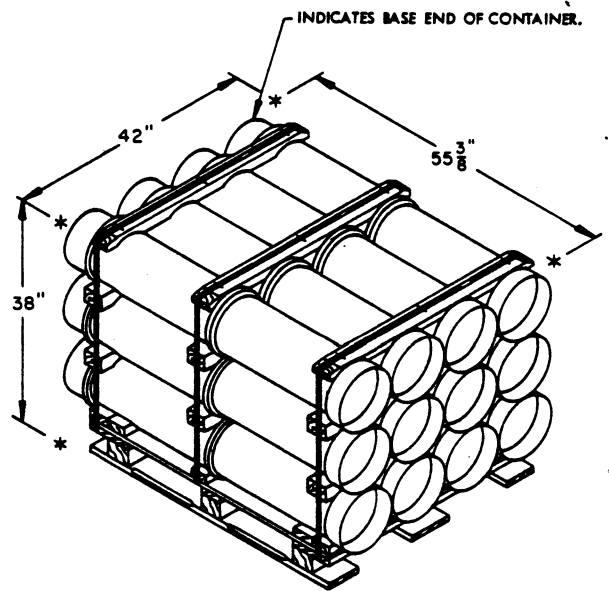

**ROUTED DUNNAGE METHOD UNIT ( DECREASED HEIGHT )**

CONTAINER ——— 12 EACH @ 121 LBS ( APPROX )  
 CUBE ——— 51.1 CUBIC FEET ( APPROX )  
 GROSS WEIGHT ——— 1,616 LBS ( APPROX )

REFER TO PAGES 76 THRU 85 FOR OUTLOADING PROCEDURES.

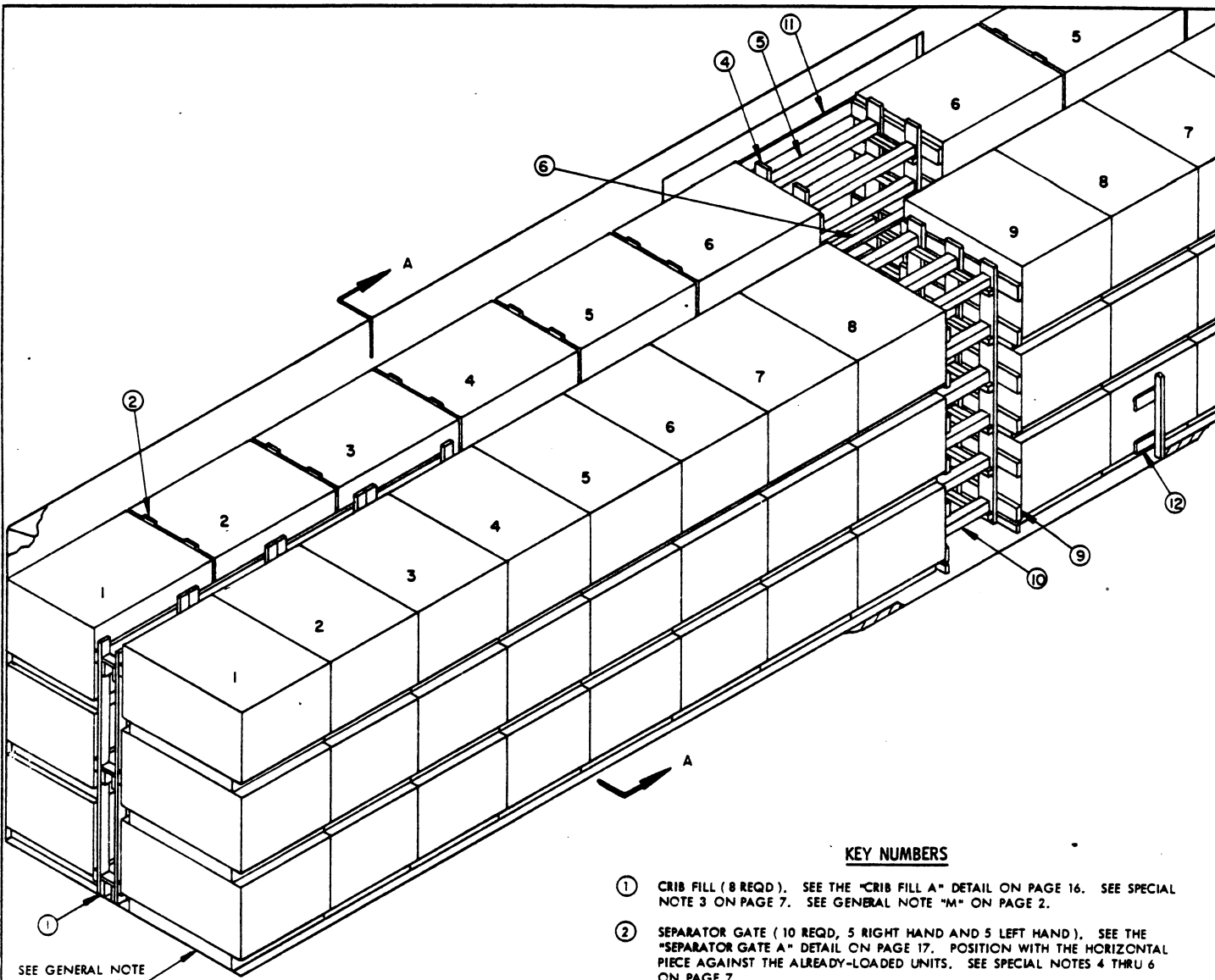

SEE GENERAL NOTE "G" ON PAGE 2.

ISOMETRIC VIEW

**KEY NUMBERS**

- ① CRIB FILL (8 REQD). SEE THE "CRIB FILL A" DETAIL ON PAGE 16. SEE SPECIAL NOTE 3 ON PAGE 7. SEE GENERAL NOTE "M" ON PAGE 2.
- ② SEPARATOR GATE (10 REQD, 5 RIGHT HAND AND 5 LEFT HAND). SEE THE "SEPARATOR GATE A" DETAIL ON PAGE 17. POSITION WITH THE HORIZONTAL PIECE AGAINST THE ALREADY-LOADED UNITS. SEE SPECIAL NOTES 4 THRU 6 ON PAGE 7.
- ③ CRIB FILL (9 REQD). SEE THE "CRIB FILL B" DETAIL ON PAGE 16.
- ④ CENTER GATE (2 REQD, 1 RIGHT HAND AND 1 LEFT HAND). SEE THE "CENTER GATE A" DETAIL ON PAGE 16. SEE SPECIAL NOTE 7 ON PAGE 7.
- ⑤ STRUT, 4" X 4" BY CUT TO FIT (REF: 48") (12 REQD). TOENAIL TO PIECES MARKED ④ W/2-16d NAILS AT EACH END. SEE GENERAL NOTES "L", "S", AND "T" ON PAGE 2.
- ⑥ STRUT, 2" X 4" BY CUT TO FIT (REF: 48") (3 REQD). TOENAIL TO THE STOP PIECES OF PIECES MARKED ④ W/2-12d NAILS AT EACH END.
- ⑦ SIDE BLOCKING FOR CENTER GATE "A", 2" X 4" X 18" (DOUBLED) (1 REQD). NAIL THE FIRST PIECE TO THE CAR FLOOR W/4-16d NAILS. NAIL THE SECOND PIECE TO THE FIRST IN A LIKE MANNER. SEE THE "PARTIAL PLAN VIEW" ON PAGE 7.
- ⑧ CRIB FILL RETAINER, 2" X 4" BY A LENGTH TO SUIT (REF: 48") (2 REQD). POSITION TO SPAN THE UPPER AND LOWER STRUTS OF LONGITUDINALLY ADJACENT CRIB FILL "B" ASSEMBLIES AT THE CENTER OF THE CAR AND NAIL TO EACH STRUT W/3-10d NAILS. SEE THE "PARTIAL PLAN VIEW" ON PAGE 7.
- ⑨ CENTER GATE (2 REQD). SEE THE "CENTER GATE B" DETAIL ON PAGE 17.
- ⑩ STRUT, 4" X 4" BY CUT TO FIT (REF: 29") (18 REQD). TOENAIL TO PIECES MARKED ⑨ W/2-16d NAILS AT EACH END.
- ⑪ DOORWAY PROTECTION (1 REQD). SEE THE "DOORWAY PROTECTION A" DETAIL ON PAGE 18. NAIL TO THE DOOR POSTS W/12d NAILS. SEE SPECIAL NOTE 8 ON PAGE 7.
- ⑫ DOORWAY PROTECTION (1 REQD). SEE THE "DOORWAY PROTECTION B" DETAIL ON PAGE 19. NAIL TO THE DOOR POSTS W/12d NAILS.

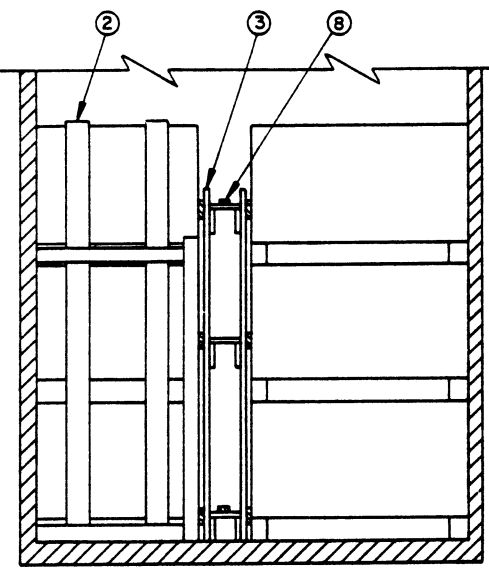

SECTION A-A

ALTERNATED CONTAINERS UNIT (BASIC HEIGHT)  
 87-UNIT LOAD IN A 60'-8" LONG BY 9'-2" WIDE CONVENTIONAL BOX CAR

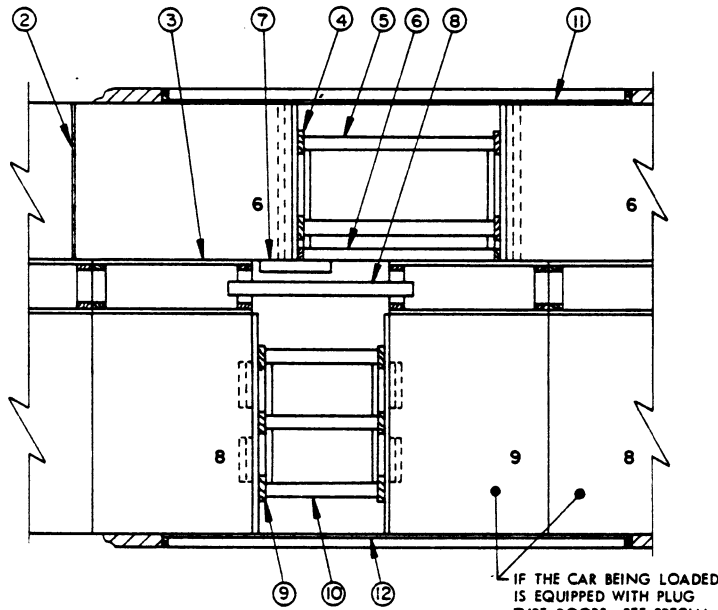

**PARTIAL PLAN VIEW**

( SPECIAL NOTES CONTINUED )

9. THE DEPICTED LOAD CAN BE REDUCED TO SUIT THE QUANTITY TO BE SHIPPED. THE LOAD CAN BE REDUCED BY ONE OR TWO PALLET UNITS BY EMPLOYING THE PROCEDURES ON PAGE 96. THREE (3) PALLET UNITS CAN BE OMITTED FROM A 3-TIER LOAD BY LEAVING OUT THE CROSSWISE STACK NO. 9 AND THE ADJACENT CRIB FILL. NOTE THAT STRUT BRACING MUST BE APPLIED TO THE STRUTS, PIECES MARKED 10, AND AN ADDITIONAL PIECE MARKED 7 WILL BE REQUIRED FOR THE OTHER CENTER GATE MARKED 4. OR, THE ENTIRE ONE OR TWO TOP TIERS CAN BE OMITTED. A PARTIAL 1-TIER LOAD CAN BE SHIPPED IN ONE OR BOTH ENDS OF A CAR BY USING KNEE BRACES AS SHOWN ON PAGES 112 AND 113.
10. IF PALLETIZED UNITS WHICH DO NOT CONTAIN A FULL QUANTITY OF CONTAINERS ARE TO BE TRANSPORTED, REFER TO PAGE 117 FOR SHIPPING GUIDANCE FOR LENGTHWISE UNITS AND PAGES 118 AND 120 FOR CROSSWISE UNITS.
11. FOR SHIPMENT OF ONE OR MORE LEFTOVER CONTAINERS, SEE THE "PROCEDURES FOR SHIPMENT OF LEFTOVER CONTAINERS" ON PAGE 119 FOR GUIDANCE.

**SPECIAL NOTES:**

1. A 60'-8" LONG BY 9'-2" WIDE WOOD-LINED CONVENTIONAL TYPE BOX CAR EQUIPPED WITH 10'-0" WIDE DOOR OPENINGS IS SHOWN. CARS OF OTHER DIMENSIONS AND CARS HAVING WIDER OR NARROWER DOOR OPENINGS CAN BE USED. SEE GENERAL NOTE "D" ON PAGE 2.
2. THE PALLET UNIT SHOWN IN THE TYPICAL LOAD ON PAGE 6 IS THE ALTERNATED CONTAINERS UNIT (BASIC HEIGHT). A MAXIMUM OF SEVENTY-TWO (72) OF THESE UNITS, FOR AN APPROXIMATE LADING WEIGHT OF 117,792 POUNDS, CAN BE PLACED IN A 50'-6" LONG CAR WHEN USING THE DEPICTED PROCEDURES; FIFTY-SEVEN (57) UNITS, FOR A LADING WEIGHT OF 93,252 POUNDS, CAN BE OUTLOADED IN A 40'-6" LONG CAR.
3. THE "HIGH" CRIB, SHOWN AS PIECE MARKED ①, MUST BE INSTALLED IN EACH END OF THE LOAD. FOUR (4) ASSEMBLIES ARE REQUIRED IN EACH END OF A LOAD REGARDLESS OF THE CAR LENGTH.
4. THE SEPARATOR GATES, SHOWN AS PIECES MARKED ② IN THE LOAD ON PAGE 6, ARE DESIGNATED "RIGHT HAND" AND "LEFT HAND" TO FACILITATE POSITIONING OF THE PALLET UNITS AS LOADING PROGRESSES. WHEN LOADING THE CAR, POSITION A PALLET UNIT STACK AGAINST THE END WALL, THEN POSITION A SEPARATOR GATE SO THE 1" X 4" TIE PIECES ARE LOCATED UNDER THE "OVERHANG" OF THE BOTTOM AND TOP PALLET UNITS IN THE FIRST STACK. REPEAT THIS PROCEDURE FOR THE REMAINING STACKS.
5. ALL SEPARATOR GATES, PIECES MARKED ②, WHICH ARE WITHIN THE DOORWAY AREA OF A CAR EQUIPPED WITH CONVENTIONAL SLIDING DOORS MUST BE WIRE TIED TO THE ADJACENT CRIB FILL TO PREVENT DISPLACEMENT. ENIRCLE THE STOP PIECE OF THE SEPARATOR GATE AND THE UPPER HORIZONTAL PIECE OF THE CRIB FILL WITH NO. 14 GAGE WIRE AND TWIST TAUT.
6. SEPARATOR GATES MAY BE FORMED FROM 3/8" OR THICKER PLYWOOD IN LIEU OF DIMENSIONAL LUMBER, IF DESIRED, FOR ONE OR TWO-LAYER LOADS; PLYWOOD SEPARATOR GATES FOR A 3-LAYER LOAD ARE NOT ECONOMICALLY FEASIBLE. CONSTRUCT EACH SEPARATOR GATE FOR ONE OR TWO-HIGH LOADS FROM 40-3/4" WIDE PLYWOOD OF AN APPROPRIATE LENGTH.
7. CENTER GATES "A" AND "B" MAY BE PARTIALLY FORMED FROM 1/2" OR THICKER PLYWOOD, IF DESIRED. PLYWOOD MAY BE USED IN LIEU OF THE 2" X 6" HORIZONTAL PIECES. SEE THE "PLYWOOD CENTER GATE ALTERNATIVE" DETAIL ON PAGE 123 FOR GUIDANCE.
8. DOORWAY PROTECTION IS REQUIRED FOR ALL PALLET UNIT STACKS WHICH ARE COMPLETELY WITHIN THE DOORWAY AREA OR WHICH EXTENDS INTO THE DOORWAY AREA BY ONE-HALF OR MORE OF THE STACK WIDTH OR LENGTH. THE WOODEN GATE TYPE OF DOORWAY PROTECTION, SHOWN AS PIECES MARKED ⑪ AND ⑫ IN THE LOAD ON PAGE 6, IS APPLICABLE FOR BOX CARS EQUIPPED WITH CONVENTIONAL SLIDING DOORS AND NAILABLE DOOR POSTS. REFER TO PAGES 126 THRU 128 FOR ALTERNATIVE DOORWAY PROTECTION FOR CARS EQUIPPED WITH CONVENTIONAL SLIDING DOORS. IF THE CAR BEING LOADED IS EQUIPPED WITH PLUG TYPE DOORS, NAILED FLOORLINE BLOCKING AND LOAD-BUNDLING STRAPS MUST BE USED. SEE THE "ALTERNATIVE DOOR PROTECTION E" AND "ALTERNATIVE DOORWAY PROTECTION F" DETAILS ON PAGE 128 FOR GUIDANCE; A COMBINATION OF THE TWO METHODS MUST BE USED. NAILED SIDE BLOCKING WILL BE USED UNDER THE CRIB FILL SHOWN IN THE DOORWAY AREA OF THE LOAD. POSITION DOUBLED 2" X 4" X 48" PIECES AGAINST THE LENGTHWISE STACK NUMBERED 6, AND PRE-POSITION DOUBLED 2" X 4" X 7'-0" PIECES (APPROXIMATELY 52" FROM THE NEAR SIDE CAR WALL) SO AS TO BE AGAINST THE CROSSWISE STACKS NUMBERED 8 AND 9. THESE PIECES WILL BE USED IN LIEU OF THE 40" AND 48" LONG PIECES SHOWN BY THE ALTERNATIVE DETAILS. A SPACER ASSEMBLY, AS SHOWN IN THE "ALTERNATIVE DOORWAY PROTECTION F" DETAIL, MUST BE MODIFIED FOR USE BY CHANGING THE END WHICH EXTENDS OVER THE CROSSWISE CONTAINERS TO BE LIKE THE NEAR END OF THE STRAPPING BOARD SHOWN IN THE "ALTERNATIVE DOORWAY PROTECTION E" DETAIL. A 2" X 4" X 40" DOUBLED BATTEN AS SHOWN IN THAT VIEW IS ALSO REQUIRED. NOTE THAT THE VERTICAL PIECES AND BOTTOM SUPPORT PIECES OF THE CRIB FILL, PIECES MARKED ③, MUST HAVE THREE INCHES (3") CUT OFF THE BOTTOM END OF ONE SIDE SO THE CRIB WILL REST EVENLY ON THE NAILED SIDE BLOCKING WHICH IS ADJACENT TO THE LENGTHWISE UNITS. ALSO NOTE THAT THE CENTER GATES "A" MUST BE WIRE TIED TO PIECE MARKED ⑧ OR THE ADJACENT CRIB FILL, AS APPLICABLE, TO PREVENT DISPLACEMENT.

( CONTINUED AT LEFT )

BILL OF MATERIAL		
LUMBER	LINEAR FEET	BOARD FEET
1" X 4"	132	44
1" X 6"	300	150
2" X 2"	68	23
2" X 3"	42	21
2" X 4"	1113	742
2" X 6"	190	190
4" X 4"	94	126
NAILS	NO. REQD	POUNDS
6d (2")	252	1-1/2
10d (3")	1846	28-1/2
12d (3-1/4")	46	1
16d (3-1/2")	128	3

**LOAD AS SHOWN**

ITEM	QUANTITY	WEIGHT (APPROX)
PALLET UNIT	87	142,332 LBS
DUNNAGE		2,626 LBS
<b>TOTAL WEIGHT</b>		<b>144,958 LBS</b>

**ALTERNATED CONTAINERS UNIT ( BASIC HEIGHT )  
87-UNIT LOAD IN A 60'-8" LONG BY 9'-2" WIDE CONVENTIONAL BOX CAR**

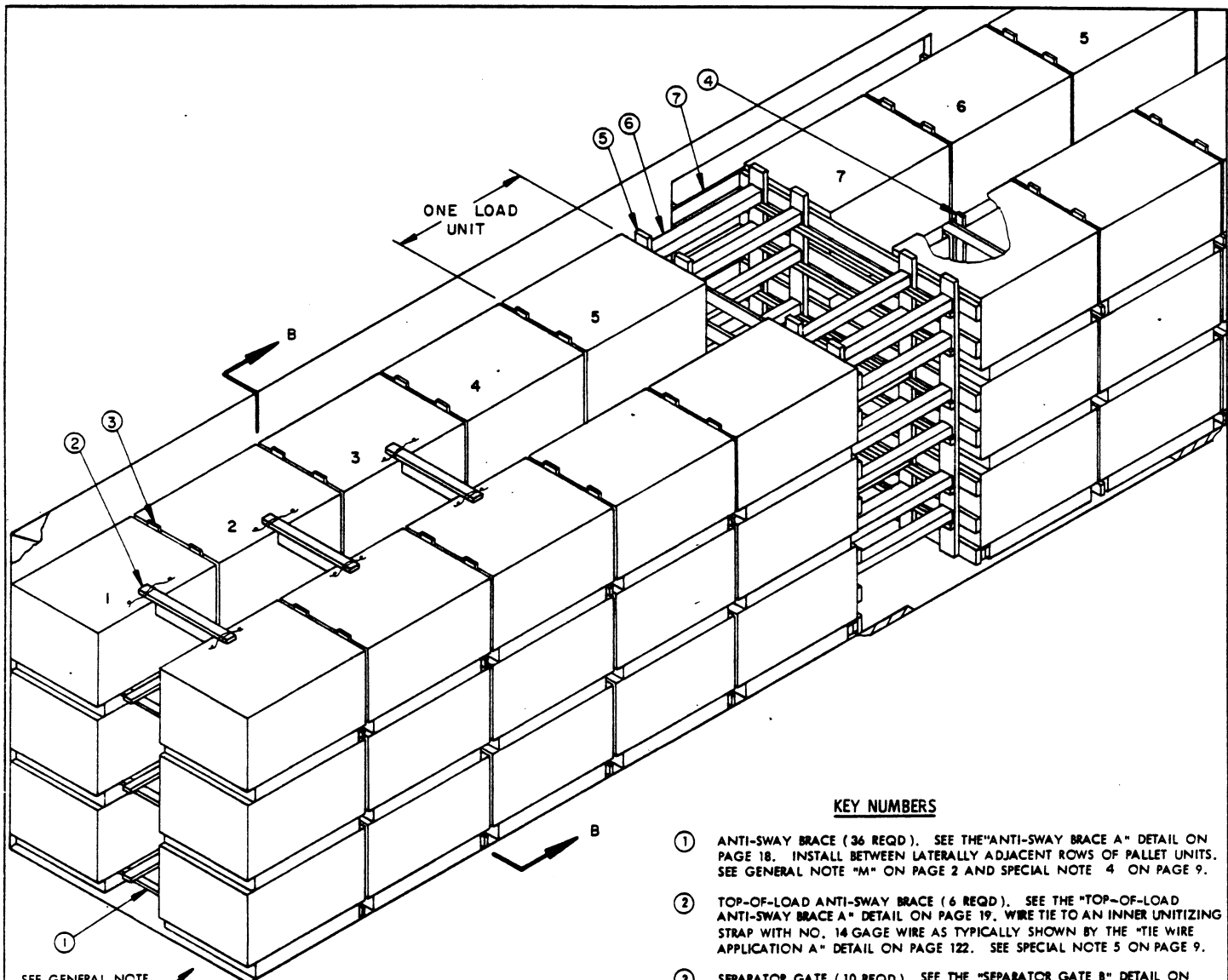

SEE GENERAL NOTE "G" ON PAGE 2

**ISOMETRIC VIEW**

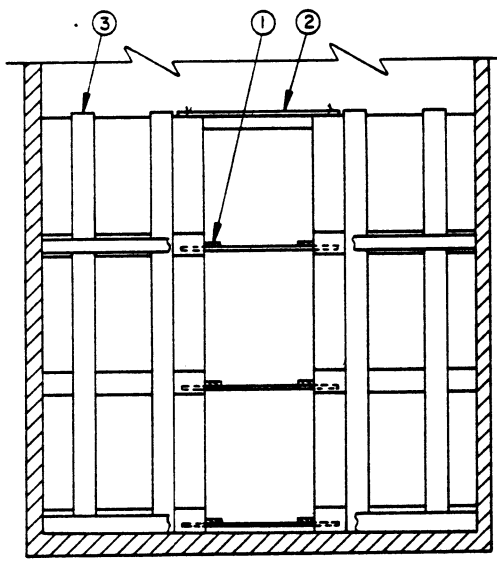

**SECTION B-B**

**KEY NUMBERS**

- ① ANTI-SWAY BRACE (36 REQD). SEE THE "ANTI-SWAY BRACE A" DETAIL ON PAGE 18. INSTALL BETWEEN LATERALLY ADJACENT ROWS OF PALLET UNITS. SEE GENERAL NOTE "M" ON PAGE 2 AND SPECIAL NOTE 4 ON PAGE 9.
- ② TOP-OF-LOAD ANTI-SWAY BRACE (6 REQD). SEE THE "TOP-OF-LOAD ANTI-SWAY BRACE A" DETAIL ON PAGE 19. WIRE TIE TO AN INNER UNITIZING STRAP WITH NO. 14 GAGE WIRE AS TYPICALLY SHOWN BY THE "TIE WIRE APPLICATION A" DETAIL ON PAGE 122. SEE SPECIAL NOTE 5 ON PAGE 9.
- ③ SEPARATOR GATE (10 REQD). SEE THE "SEPARATOR GATE B" DETAIL ON PAGE 17. POSITION WITH THE HORIZONTAL PIECE AGAINST THE ALREADY-LOADED UNITS. SEE SPECIAL NOTES 6 AND 8 ON PAGE 9.
- ④ STOP PIECE, 1" X 4" X 6'-6" (2 REQD). INSTALL ON THE SIDE OPPOSITE THE VERTICAL PIECES OF THE SEPARATOR GATE, PIECE MARKED ③, WHICH IS IN THE DOORWAY AREA. POSITION IN CONTACT WITH THE ADJACENT PALLET UNITS AND NAIL TO THE HORIZONTAL PIECES W/3-6d NAILS AT EACH JOINT AND CLINCH. SEE SPECIAL NOTE 7 ON PAGE 9.
- ⑤ CENTER GATE (2 REQD). SEE THE "CENTER GATE C" DETAIL ON PAGE 18. SEE SPECIAL NOTES 9, 10, AND 13 ON PAGE 9.
- ⑥ STRUT, 4" X 4" BY CUT TO FIT (REF: 48") (24 REQD). TCENAIL TO PIECES MARKED ③ W/2-16d NAILS AT EACH END. SEE GENERAL NOTES "L", "S", AND "T" ON PAGE 2.
- ⑦ DOORWAY PROTECTION (2 REQD). SEE THE "DOORWAY PROTECTION A" DETAIL ON PAGE 18. NAIL TO THE DOOR POSTS W/12d NAILS. SEE SPECIAL NOTE 12 ON PAGE 9.

**ALTERNATED CONTAINERS UNIT ( BASIC HEIGHT )  
72-UNIT LOAD IN A 60'-8" LONG BY 9'-2" WIDE CONVENTIONAL BOX CAR**



( SPECIAL NOTES CONTINUED )

12. DOORWAY PROTECTION IS REQUIRED FOR ALL PALLET UNIT STACKS WHICH ARE COMPLETELY WITHIN THE DOORWAY AREA OR WHICH EXTEND INTO THE DOORWAY AREA BY ONE-HALF OR MORE OF THE STACK WIDTH. THE WOODEN GATE TYPE OF DOORWAY PROTECTION, SHOWN AS PIECES MARKED (7) IN THE LOAD ON PAGE 8, IS APPLICABLE FOR BOXCARS EQUIPPED WITH CONVENTIONAL SLIDING DOORS AND AVAILABLE DOOR POSTS. REFER TO PAGES 126 THRU 128 FOR ALTERNATIVE DOORWAY PROTECTION FOR CARS EQUIPPED WITH CONVENTIONAL SLIDING DOORS. IF THE CAR BEING LOADED IS EQUIPPED WITH PLUG TYPE DOORS, NAILED FLOORLINE BLOCKING AND LOAD BUNDLING STRAPS MUST BE USED. SEE THE "ALTERNATIVE DOORWAY PROTECTION F" DETAIL ON PAGE 128 FOR GUIDANCE. SEE SPECIAL NOTE 13.
13. IF THE "ALTERNATIVE DOORWAY PROTECTION F" PROCEDURES SHOWN ON PAGE 128 ARE USED IN LIEU OF THE WOODEN DOORWAY PROTECTION, PIECES MARKED (7), THE CENTER GATES MUST BE RESTRAINED FROM LATERAL MOVEMENT. THIS CAN BE ACCOMPLISHED BY NAILING TO THE CAR FLOOR A DOUBLED 2" X 4" X 18" PIECE POSITIONED LONGITUDINALLY SO AS TO BE CENTERED AGAINST THE FILL PIECE OF A CENTER GATE. TWO (2) PIECES WILL BE REQUIRED FOR EACH CENTER GATE WHICH IS IN THE DOOR OPENING OR WITHIN SIX INCHES (6") OF BEING IN THE OPENING.
14. THE DEPICTED LOAD CAN BE REDUCED TO SUIT THE QUANTITY TO BE SHIPPED. A 3-TIER LOAD CAN BE REDUCED BY A MULTIPLE OF SIX (6) PALLET UNITS, A 2-TIER LOAD CAN BE REDUCED BY A MULTIPLE OF FOUR (4) UNITS, OR A 1-TIER LOAD CAN BE REDUCED BY A MULTIPLE OF TWO (2) UNITS BY OMITTING ONE OR MORE LOAD UNITS FROM THE CENTER PORTION OF THE LOAD. OR, THE ENTIRE ONE OR TWO TOP TIERS CAN BE OMITTED. FOR OTHER METHODS OF REDUCING A LOAD, AND FOR TYPICAL LCL PROCEDURES, REFER TO PAGES 92 THRU 120 FOR GUIDANCE.
15. IF PALLET UNITS WHICH DO NOT CONTAIN A FULL QUANTITY OF CONTAINERS ARE TO BE TRANSPORTED, REFER TO PAGE 117 FOR SHIPPING GUIDANCE.
16. FOR SHIPMENT OF ONE OR MORE LEFTOVER CONTAINERS, SEE THE "PROCEDURES FOR SHIPMENT OF LEFTOVER CONTAINERS" ON PAGE 119 FOR GUIDANCE.

SPECIAL NOTES:

1. A 60'-8" LONG BY 9'-2" WIDE WOOD-LINED CONVENTIONAL TYPE BOXCAR EQUIPPED WITH 10'-0" WIDE DOOR OPENINGS IS SHOWN. CARS OF OTHER DIMENSIONS AND CARS HAVING WIDER OR NARROWER DOOR OPENINGS CAN BE USED. SEE GENERAL NOTE "D" ON PAGE 2 AND SPECIAL NOTE 3 BELOW.
2. THE PALLET UNIT SHOWN IN THE TYPICAL LOAD ON PAGE 8 IS THE ALTERNATED CONTAINERS UNIT (BASIC HEIGHT). A MAXIMUM OF SIXTY (60) OF THESE UNITS, FOR AN APPROXIMATE LADING WEIGHT OF 98,160 POUNDS, CAN BE PLACED IN A 50'-6" LONG CAR WHEN USING THE DEPICTED PROCEDURES; FORTY-EIGHT (48) UNITS, FOR AN APPROXIMATE LADING WEIGHT OF 78,528 POUNDS, CAN BE OUT-LOADED IN A 40'-6" LONG CAR.
3. THE DEPICTED LOADING PATTERN IS ADEQUATE FOR CARS HAVING DOOR OPENINGS 8' THRU 10' OR WIDER. IF THE CAR TO BE LOADED HAS DOOR OPENINGS LESS THAN 8'-0" WIDE AND NOT OF SUFFICIENT HEIGHT TO ALLOW PERSONNEL TO EXIT THE CAR OVER THE TOP OF THE LOAD WHEN NECESSARY, THE PALLETS SHOULD BE POSITIONED SO THERE ARE SIX (6) LOAD UNITS IN EACH END. NOTE THAT ALTHOUGH CARS HAVING DOOR OPENINGS AS NARROW AS 6'-0" WIDE CAN BE USED FOR FULL LOADS, LOADING IS PROGRESSIVELY MORE DIFFICULT AS THE WIDTH OF THE DOOR OPENING DECREASES.
4. IF THE "ALTERNATIVE DOORWAY PROTECTION F" PROCEDURES AS SHOWN ON PAGE 128 ARE USED IN LIEU OF THE WOODEN DOORWAY PROTECTION, PIECE MARKED (7), NAILED FLOORLINE BLOCKING MUST BE USED IN LIEU OF EACH LOWER ANTI-SWAY BRACE IN THE DOORWAY AREA. NAILED BLOCKING IS REQUIRED FOR ALL PALLET STACKS WHICH ARE COMPLETELY WITHIN THE DOORWAY AREA OR WHICH EXTEND INTO THE DOORWAY AREA BY ONE-HALF OR MORE OF THE STACK WIDTH ON EITHER SIDE OF THE CAR. SEE SPECIAL NOTE 12.
5. TOP-OF-LOAD ANTI-SWAY BRACES, SHOWN AS PIECES MARKED (8) IN THE LOAD ON PAGE 8, MUST BE INSTALLED IN EACH END OF THE CAR AND WIRE TIED TO A UNITIZING STRAP WITH NO. 14 GAGE WIRE AS TYPICALLY SHOWN BY THE "TIE WIRE APPLICATION A" DETAIL ON PAGE 122. THREE (3) BRACES ARE REQUIRED IN EACH END OF A LOAD REGARDLESS OF THE CAR LENGTH.
6. TO FACILITATE POSITIONING OF THE PALLET UNITS AS LOADING PROGRESSES, POSITION PALLET UNIT STACKS AGAINST THE END WALL, THEN POSITION A SEPARATOR GATE, SHOWN AS PIECE MARKED (9), SO THE 1" X 4" TIE PIECES ARE LOCATED UNDER THE "OVERHANG" OF THE PALLET UNITS. REPEAT THIS PROCEDURE FOR THE REMAINING STACKS.
7. SEPARATOR GATES IN THE DOORWAY MUST BE PREVENTED FROM SHIFTING INTO A DOOR OPENING BY THE APPLICATION OF THE STOP PIECES, PIECES MARKED (4). IN CARS EQUIPPED WITH STAGGERED DOORS, STOP PIECES MAY BE REQUIRED ON UP TO FOUR SEPARATOR GATES.
8. SEPARATOR GATES MAY BE FORMED FROM 3/8" OR THICKER PLYWOOD IN LIEU OF DIMENSIONAL LUMBER, IF DESIRED, FOR ONE OR TWO-LAYER LOADS; PLYWOOD SEPARATOR GATES FOR A 3-LAYER LOAD ARE NOT ECONOMICALLY FEASIBLE. SEE THE "ALTERNATIVE SEPARATOR GATE" DETAIL ON PAGE 122 FOR CONSTRUCTION GUIDANCE.
9. CENTER GATE "C" MAY BE PARTIALLY FORMED FROM 1/2" OR THICKER PLYWOOD, IF DESIRED. PLYWOOD MAY BE USED IN LIEU OF THE 2" X 6" HORIZONTAL PIECES. SEE THE "PLYWOOD CENTER GATE ALTERNATIVE" DETAIL ON PAGE 123 FOR GUIDANCE.
10. FOR EASE OF HANDLING, SPLIT CENTER GATES, WHICH ARE NOT DEPENDENT UPON THE WIDTH OF THE CAR, MAY BE USED AS AN ALTERNATIVE TO THE CAR-WIDTH GATES. IN LIEU OF EACH "CENTER GATE C", SHOWN AS PIECE MARKED (9) IN THE LOAD ON PAGE 8, INSTALL TWO (2) "CENTER GATES A" AS SHOWN ON PAGE 16. AFTER THE SPLIT GATES AND STRUTS HAVE BEEN INSTALLED, THE SPLIT GATES MUST BE TIED TOGETHER AS DEPICTED BY THE "TIE PIECE APPLICATION" DETAIL ON PAGE 123. OMIT THE STOP PIECES FROM "CENTER GATE A".
11. DOOR SPANNER TYPE GATE HOLD DOWN MAY BE USED IN LIEU OF THE DOUBLED 2" X 4" MATERIAL NAILED TO CENTER GATE C, PROVIDING THE CAR BEING LOADED HAS NAILABLE SIDEWALLS. SEE THE DETAILS ON PAGE 125 FOR GUIDANCE.

( CONTINUED AT LEFT )

BILL OF MATERIAL		
LUMBER	LINEAR FEET	BOARD FEET
1" X 4"	196	66
1" X 6"	480	240
2" X 2"	95	32
2" X 3"	33	17
2" X 4"	526	351
2" X 6"	196	196
4" X 4"	100	134
NAILS	NO. REQD	POUNDS
6d (2")	324	2
10d (3")	736	11-1/2
12d (3-1/4")	62	1-1/4
16d (3-1/2")	96	2-1/4
WIRE, NO. 14 GAGE	36' REQD	1/2 LB

LOAD AS SHOWN		
ITEM	QUANTITY	WEIGHT ( APPROX )
PALLET UNIT	72	117,792 LBS
DUNNAGE		2,094 LBS
TOTAL WEIGHT		119,886 LBS

ALTERNATED CONTAINERS UNIT ( BASIC HEIGHT )  
72-UNIT LOAD IN A 60'-8" LONG BY 9'-2" WIDE CONVENTIONAL BOX CAR

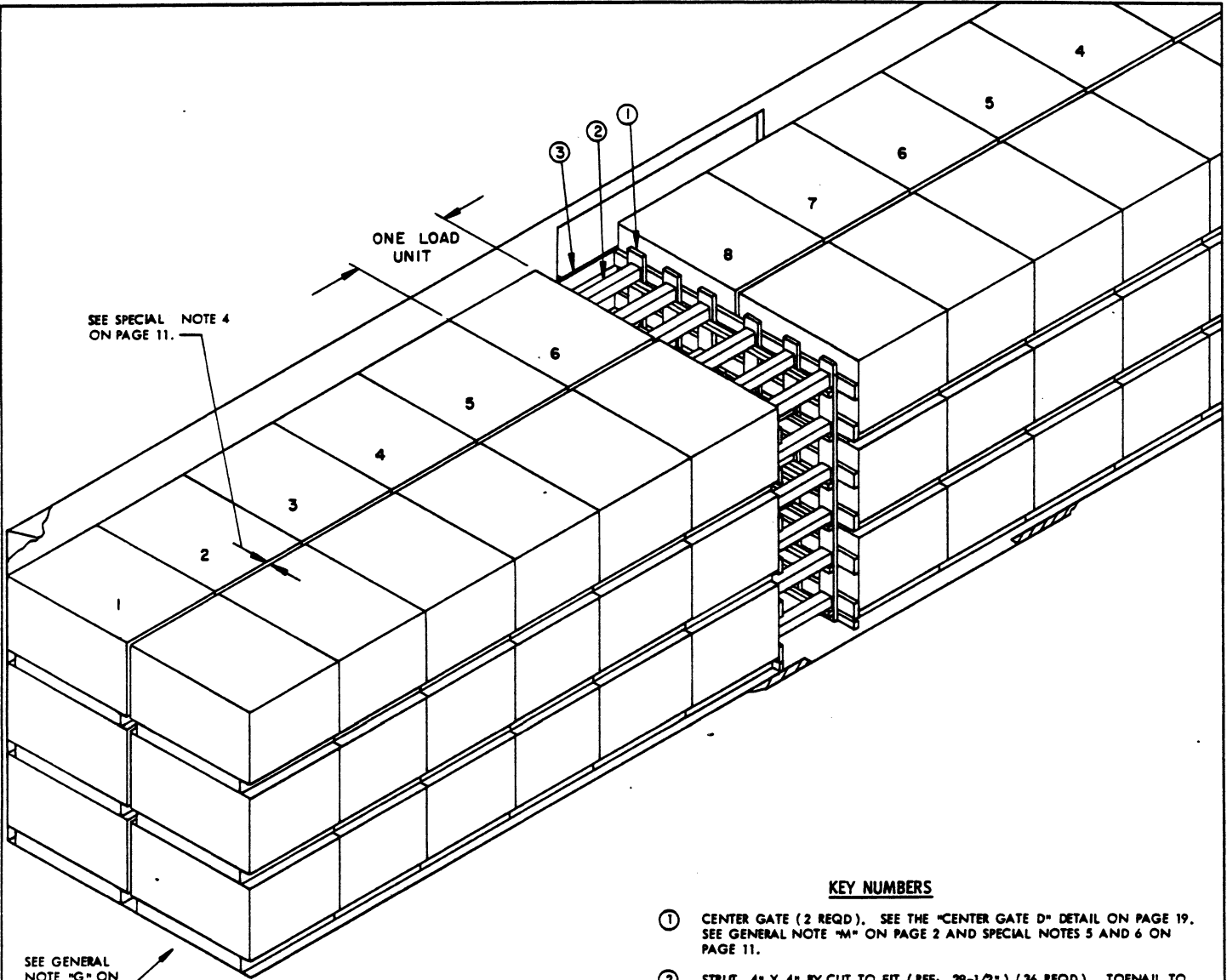

ISOMETRIC VIEW

**KEY NUMBERS**

- ① CENTER GATE (2 REQD). SEE THE "CENTER GATE D" DETAIL ON PAGE 19. SEE GENERAL NOTE "M" ON PAGE 2 AND SPECIAL NOTES 5 AND 6 ON PAGE 11.
- ② STRUT, 4" X 4" BY CUT TO FIT (REF: 29'-1/2") (36 REQD). TOENAIL TO PIECES MARKED ① W/2-16d NAILS AT EACH END. SEE GENERAL NOTES "L", "S", AND "T" ON PAGE 2.
- ③ DOORWAY PROTECTION (2 REQD). SEE THE "DOORWAY PROTECTION B" DETAIL ON PAGE 19. NAIL TO THE DOOR POSTS W/12d NAILS. SEE SPECIAL NOTE 8 ON PAGE 11.

**SPECIAL NOTES:**

1. A 50'-6" LONG BY 9'-4" WIDE WOOD-LINED CONVENTIONAL TYPE BOXCAR EQUIPPED WITH 8'-0" WIDE DOOR OPENINGS IS SHOWN. WIDER CARS OF OTHER LENGTHS AND CARS HAVING WIDER OR NARROWER DOOR OPENINGS CAN BE USED. SEE GENERAL NOTE "D" ON PAGE 2 AND SPECIAL NOTE 3 BELOW.
2. THE PALLET UNIT SHOWN IN THE TYPICAL LOAD ON PAGE 10 IS THE ALTERNATED CONTAINERS UNIT (BASIC HEIGHT). A MAXIMUM OF SIXTY-SIX (66) OF THESE UNITS, FOR AN APPROXIMATE LADING WEIGHT OF 107,976 POUNDS, CAN BE PLACED IN A 40'-6" LONG CAR WHEN USING THE DEPICTED PROCEDURES. IF A 60'-8" LONG BY 9'-4" OR WIDER CAR IS AVAILABLE, ONE HUNDRED AND TWO (102) PALLET UNITS FOR AN APPROXIMATE LADING WEIGHT OF 165,236 POUNDS CAN BE LOADED, LOAD LIMIT OF THE CAR PERMITTING.
3. THE DEPICTED LOADING PATTERN IS ADEQUATE FOR CARS HAVING DOOR OPENINGS 8' OR WIDER. IF THE CAR TO BE LOADED HAS DOOR OPENINGS LESS THAN 8'-0" WIDE AND NOT OF SUFFICIENT HEIGHT TO ALLOW PERSONNEL TO EXIT THE CAR OVER THE TOP OF THE LOAD WHEN NECESSARY, THE PALLETS SHOULD BE POSITIONED SO THERE ARE SEVEN (7) LOAD UNITS IN EACH END. NOTE THAT ALTHOUGH CARS HAVING DOOR OPENINGS AS NARROW AS 6'-0" WIDE CAN BE USED FOR FULL LOADS, LOADING IS PROGRESSIVELY MORE DIFFICULT AS THE WIDTH OF THE DOOR OPENING DECREASES.
4. ANTI-SWAY BRACING BETWEEN LATERALLY ADJACENT ROWS OF PALLET UNITS IS NOT REQUIRED REGARDLESS OF THE WIDTH OF THE CAR BEING LOADED.
5. CENTER GATE "D" MAY BE PARTIALLY FORMED FROM 1/2" OR THICKER PLYWOOD, IF DESIRED. PLYWOOD MAY BE USED IN LIEU OF THE 2" X 6" HORIZONTAL PIECES. SEE THE "PLYWOOD CENTER GATE ALTERNATIVE" DETAIL ON PAGE 123 FOR GUIDANCE.
6. FOR EASE OF HANDLING, SPLIT CENTER GATES, WHICH ARE NOT DEPENDENT UPON THE WIDTH OF THE CAR, MAY BE USED AS AN ALTERNATIVE TO THE CAR-WIDTH GATES. IN LIEU OF EACH "CENTER GATE D", SHOWN AS PIECE MARKED ① IN THE LOAD ON PAGE 10, INSTALL TWO (2) "CENTER GATES B" AS SHOWN ON PAGE 17. AFTER THE SPLIT GATES AND STRUTS HAVE BEEN INSTALLED, THE SPLIT GATES MUST BE TIED TOGETHER AS DEPICTED BY THE "TIE PIECE APPLICATION" DETAIL ON PAGE 123.
7. DOOR SPANNER TYPE GATE HOLD DOWN MAY BE USED IN LIEU OF THE DOUBLED 2" X 3" HOLD DOWNS ON CENTER GATES "D", PROVIDING THE CAR BEING LOADED HAS NAILABLE SIDEWALLS. SEE THE DETAILS ON PAGE 125 FOR GUIDANCE.
8. DOORWAY PROTECTION IS REQUIRED FOR ALL PALLET UNIT STACKS WHICH ARE COMPLETELY WITHIN THE DOORWAY AREA OR WHICH EXTEND INTO THE DOORWAY AREA BY ONE-HALF OR MORE OF THE STACK LENGTH. THE WOODEN GATE TYPE OF DOORWAY PROTECTION SHOWN AS PIECES MARKED ② IN THE LOAD ON PAGE 10 IS APPLICABLE FOR BOXCARS EQUIPPED WITH CONVENTIONAL SLIDING DOORS AND NAILABLE DOOR POSTS. REFER TO PAGES 126 THRU 128 FOR ALTERNATIVE DOORWAY PROTECTION FOR CARS EQUIPPED WITH CONVENTIONAL SLIDING DOORS. IF THE CAR BEING LOADED IS EQUIPPED WITH PLUG TYPE DOORS, NAILABLE FLOORLINE BLOCKING AND LOAD BUNDLING STRAPS MUST BE USED. SEE THE "ALTERNATIVE DOORWAY PROTECTION E" DETAIL ON PAGE 128 FOR GUIDANCE.
9. THE DEPICTED LOAD CAN BE REDUCED TO SUIT THE QUANTITY TO BE SHIPPED. A 3-TIER LOAD CAN BE REDUCED BY A MULTIPLE OF SIX (6) PALLET UNITS, A 2-TIER LOAD CAN BE REDUCED BY A MULTIPLE OF FOUR (4) UNITS, OR A 1-TIER LOAD CAN BE REDUCED BY A MULTIPLE OF TWO (2) UNITS BY OMITTING ONE OR MORE LOAD UNITS FROM THE CENTER PORTION OF THE LOAD. OR, THE ENTIRE ONE OR TWO TOP TIERS CAN BE OMITTED. FOR OTHER METHODS OF REDUCING A LOAD, AND FOR TYPICAL LCL PROCEDURES, REFER TO PAGES 92 THRU 120 FOR GUIDANCE.
10. IF PALLETIZED UNITS WHICH DO NOT CONTAIN A FULL QUANTITY OF CONTAINERS ARE TO BE TRANSPORTED, REFER TO PAGES 118 AND 120 FOR SHIPPING GUIDANCE.
11. FOR SHIPMENT OF ONE OR MORE LEFTOVER CONTAINERS, SEE THE "PROCEDURES FOR SHIPMENT OF LEFTOVER CONTAINERS" ON PAGE 119 FOR GUIDANCE.

BILL OF MATERIAL		
LUMBER	LINEAR FEET	BOARD FEET
1" X 6"	96	48
2" X 2"	112	38
2" X 3"	41	21
2" X 4"	19	13
2" X 6"	215	215
4" X 4"	89	119
NAILS	NO. REQD	POUNDS
6d (2")	72	1/2
10d (3")	420	6-1/2
12d (3-1/4")	32	3/4
16d (3-1/2")	144	3-1/4

**LOAD AS SHOWN**

ITEM	QUANTITY	WEIGHT (APPROX)
PALLET UNIT	84	137,424 LBS
DUNNAGE		919 LBS
<b>TOTAL WEIGHT</b>		<b>138,343 LBS</b>

ALTERNATED CONTAINERS UNIT (BASIC HEIGHT)  
 84-UNIT LOAD IN A 50'-6" LONG BY 9'-4" WIDE CONVENTIONAL BOX CAR

**CAR EQUIPMENT REQUIRED**

ADJUSTABLE WALL MEMBER	32
(SEE "NOTE 1" BELOW)	
CROSS MEMBERS	28
DOORWAY MEMBERS	8

NOTE 1: FOR CARS EQUIPPED WITH FIXED WALL MEMBERS LOCATED AT THE HEIGHTS SPECIFIED IN "SECTION C-C"; OMIT ALL REFERENCE TO "ADJUSTABLE WALL MEMBERS".

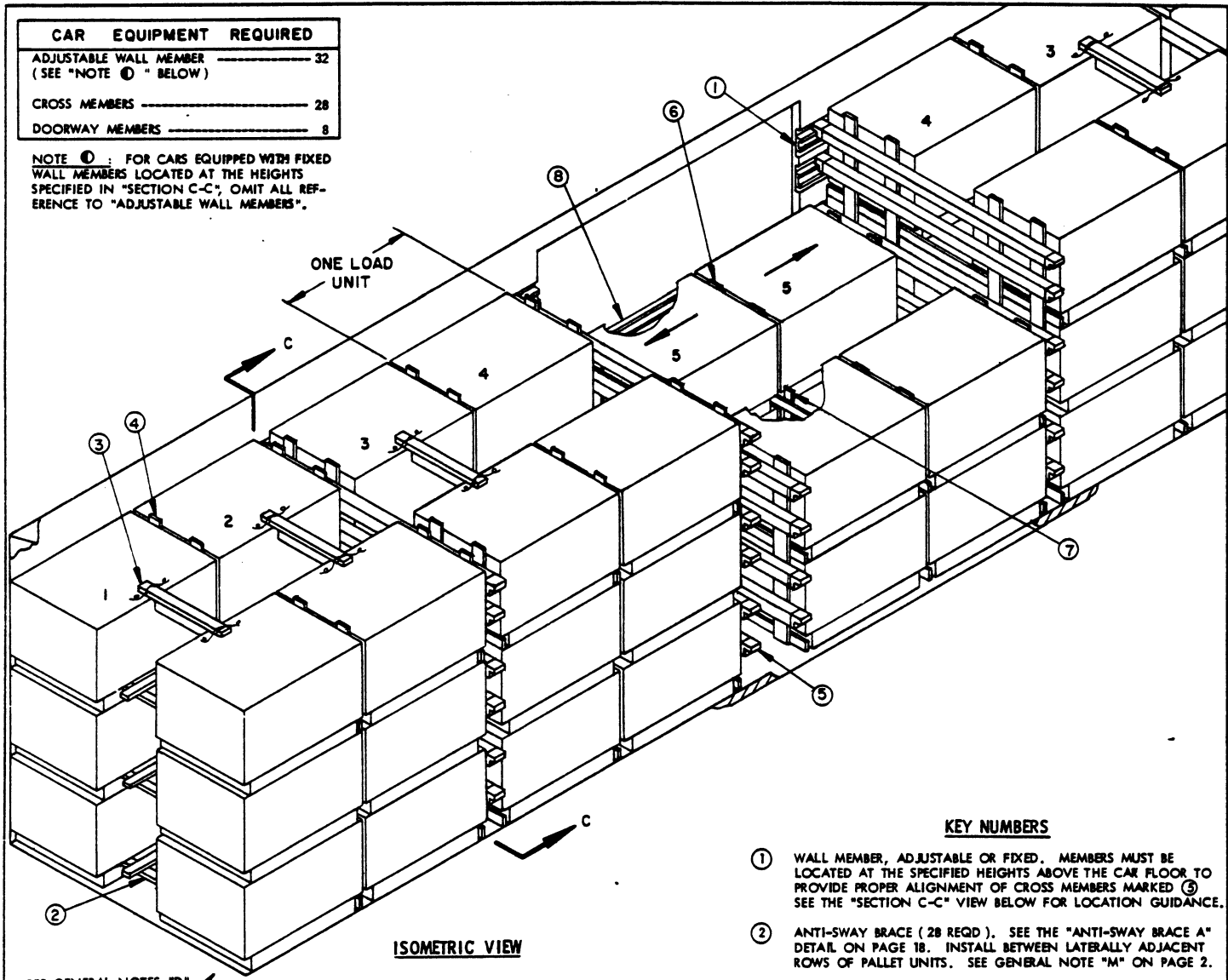

**ISOMETRIC VIEW**

SEE GENERAL NOTES "D" AND "G" ON PAGE 2 AND SPECIAL NOTE 3 ON PAGE 13.

EACH DIMENSIONED HEIGHT ABOVE THE CAR FLOOR TO AN ADJUSTABLE OR FIXED WALL MEMBER MARKED 1 AND/OR A DOORWAY MEMBER MARKED 8 IS SPECIFIED TO LOCATE THE CENTER LINE OF A CROSS MEMBER.

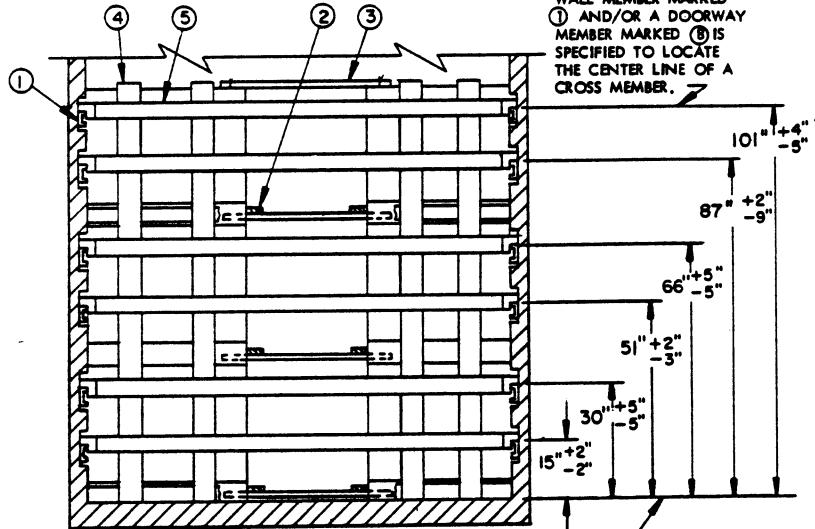

**SECTION C-C**

INDICATES CAR FLOOR.

**KEY NUMBERS**

- 1 WALL MEMBER, ADJUSTABLE OR FIXED. MEMBERS MUST BE LOCATED AT THE SPECIFIED HEIGHTS ABOVE THE CAR FLOOR TO PROVIDE PROPER ALIGNMENT OF CROSS MEMBERS MARKED 5. SEE THE "SECTION C-C" VIEW BELOW FOR LOCATION GUIDANCE.
- 2 ANTI-SWAY BRACE (28 REQD). SEE THE "ANTI-SWAY BRACE A" DETAIL ON PAGE 18. INSTALL BETWEEN LATERALLY ADJACENT ROWS OF PALLET UNITS. SEE GENERAL NOTE "M" ON PAGE 2.
- 3 TOP-OF-LOAD ANTI-SWAY BRACE (6 REQD). SEE THE "TOP-OF-LOAD ANTI-SWAY BRACE A" DETAIL ON PAGE 19. WIRE TIE TO AN INNER UNITIZING STRAP WITH NO. 14 GAGE WIRE AS TYPICALLY SHOWN BY THE "TIE WIRE APPLICATION A" DETAIL ON PAGE 122. SEE SPECIAL NOTE 4 ON PAGE 13.
- 4 SEPARATOR GATE FOR 3-HIGH (10 REQD). SEE THE "SEPARATOR GATE B" DETAIL ON PAGE 17. AS APPLICABLE, POSITION WITH THE HORIZONTAL PIECES AGAINST THE ALREADY-LOADED UNITS. SEE SPECIAL NOTES 5 AND 7 ON PAGE 13.
- 5 CROSS MEMBER (28 REQD). SEE GENERAL NOTE "W" ON PAGE 3.
- 6 SEPARATOR GATE FOR 2-HIGH (3 REQD). SEE THE "SEPARATOR GATE B" DETAIL ON PAGE 17. AS APPLICABLE, POSITION WITH THE HORIZONTAL PIECES AGAINST THE ALREADY-LOADED UNITS.
- 7 STOP PIECE, 1" X 4" X 42" (4 REQD). POSITION AGAINST PALLET UNITS IN THE DOORWAY AND NAIL TO THE HORIZONTAL PIECES ON PIECE MARKED 6 W/3-6d NAILS AT EACH JOINT AND CLINCH. SEE SPECIAL NOTE 6 ON PAGE 13.
- 8 DOORWAY MEMBER (8 REQD). SEE THE "SECTION C-C" VIEW AT LEFT FOR LOCATION GUIDANCE. SEE SPECIAL NOTE 8 ON PAGE 13.

ALTERNATED CONTAINERS UNIT (BASIC HEIGHT)

56-UNIT LOAD IN A 50'-0" LONG BY 9'-0" WIDE BOX CAR EQUIPPED WITH MECHANICAL BRACING DEVICES

**SPECIAL NOTES:**

1. A 50'-6" LONG BY 9'-0" WIDE (INSIDE CLEARANCE) WOOD-LINED BOX CAR EQUIPPED WITH ADJUSTABLE AND/OR FIXED WALL MEMBERS, AND WITH 10'-0" WIDE DOOR OPENINGS IS SHOWN. CARS OF OTHER DIMENSIONS AND CARS HAVING WIDER OR NARROWER DOOR OPENINGS CAN BE USED. SEE GENERAL NOTE "D" ON PAGE 2.
2. THE PALLET UNIT SHOWN IN THE TYPICAL LOAD ON PAGE 12 IS THE ALTERNATED CONTAINERS UNIT (BASIC HEIGHT). A MAXIMUM OF FORTY-FOUR (44) OF THESE UNITS, FOR AN APPROXIMATE LADING WEIGHT OF 71,984 POUNDS, CAN BE PLACED IN A 40'-6" LONG CAR.
3. IF A CAR HAS BOWED END WALLS WHICH ARE BOWED OUTWARD TWO INCHES (2") OR MORE EITHER FROM SIDE-TO-SIDE OR FROM FLOOR-TO-ROOF, CROSS MEMBERS CAN BE INSTALLED NEAR THE END WALL OF THE CAR TO PROVIDE A "SQUARED END" RATHER THAN INSTALLING DUNNAGE AS SPECIFIED IN GENERAL NOTE "G" ON PAGE 2. THESE CROSS MEMBERS SHOULD BE INSTALLED AT THE SAME HEIGHTS AS THE CROSS MEMBERS USED THROUGHOUT THE LOAD AS BLOCKING MEMBERS. A SEPARATOR GATE SHOWN AS PIECE MARKED ④, MUST BE POSITIONED AGAINST THESE CROSS MEMBERS PRIOR TO LOADING.
4. TOP-OF-LOAD ANTI-SWAY BRACES, SHOWN AS PIECES MARKED ③ IN THE LOAD ON PAGE 12, MUST BE INSTALLED IN EACH END OF THE CAR AND WIRE TIED TO A UNITIZING STRAP WITH NO. 14 GAGE WIRE AS TYPICALLY SHOWN BY THE "TIE WIRE APPLICATION A" DETAIL ON PAGE 122. THREE (3) BRACES ARE REQUIRED IN EACH END OF A LOAD REGARDLESS OF THE CAR LENGTH.
5. TO FACILITATE POSITIONING OF THE PALLET UNITS AS LOADING PROGRESSES, POSITION PALLET UNIT STACKS AGAINST THE END WALL, THEN POSITION A SEPARATOR GATE SHOWN AS PIECES MARKED ④ SO THE 1" X 4" TIE PIECES ARE LOCATED UNDER THE "OVERHANG" OF THE BOTTOM AND TOP PALLET UNITS. REPEAT THIS PROCEDURE FOR THE REMAINING STACKS.
6. SEPARATOR GATES IN THE DOORWAY MUST BE PREVENTED FROM SHIFTING INTO A DOOR OPENING BY THE APPLICATION OF THE STOP PIECES, PIECES MARKED ⑦ IN CARS EQUIPPED WITH STAGGERED DOORS, STOP PIECES MAY BE REQUIRED ON UP TO FOUR SEPARATOR GATES.
7. SEPARATOR GATES MAY BE FORMED FROM 3/8" OR THICKER PLYWOOD IN LIEU OF DIMENSIONAL LUMBER, IF DESIRED, FOR ONE OR TWO-LAYER LOADS; PLYWOOD SEPARATOR GATES FOR A 3-LAYER LOAD ARE NOT ECONOMICALLY FEASIBLE. SEE THE "ALTERNATIVE SEPARATOR GATE" DETAIL ON PAGE 122 FOR CONSTRUCTION GUIDANCE.
8. IF THE CAR BEING LOADED IS EQUIPPED WITH AT LEAST TWELVE (12) DOORWAY MEMBERS, AN ADDITIONAL FOUR PALLET UNITS CAN BE LOADED IN THE DOORWAY AREA.
9. THE DEPICTED LOAD CAN BE REDUCED TO SUIT THE QUANTITY TO BE SHIPPED. A LOAD MAY BE REDUCED BY MULTIPLES OF TWO (2) PALLET UNITS BY OMITTING LATERALLY ADJACENT UNITS FROM THE TOP ONE OR TWO LAYERS OF ONE OR MORE LOAD UNITS, OR BY MULTIPLES OF SIX (6) PALLET UNITS BY OMITTING ONE OR MORE ENTIRE LOAD UNITS. TO REDUCE A LOAD BY ONE (1) PALLET UNIT, REFER TO THE LCL PROCEDURES ON PAGES 90 AND 91 FOR GUIDANCE.
10. FOR SHIPMENT OF ONE OR MORE LEFTOVER CONTAINERS, SEE THE "PROCEDURES FOR SHIPMENT OF LEFTOVER CONTAINERS" ON PAGE 119 FOR GUIDANCE.

BILL OF MATERIAL		
LUMBER	LINEAR FEET	BOARD FEET
1" X 4"	248	83
1" X 6"	432	216
2" X 4"	399	266
NAILS	NO. REQD	POUNDS
6d (2")	336	2
10d (3")	336	5-1/4
12d (3-1/4")	30	1/2
WIRE, NO. 14 GAGE	36' REQD	NIL

**LOAD AS SHOWN**

ITEM	QUANTITY	WEIGHT (APPROX)
PALLET UNIT	56	91,616 LBS
DUNNAGE		1,138 LBS
		<b>TOTAL WEIGHT—92,754 LBS</b>

ALTERNATED CONTAINERS UNIT (BASIC HEIGHT)  
**56-UNIT LOAD IN A 50'-6" LONG BY 9'-0" WIDE BOX CAR EQUIPPED WITH MECHANICAL BRACING DEVICES**

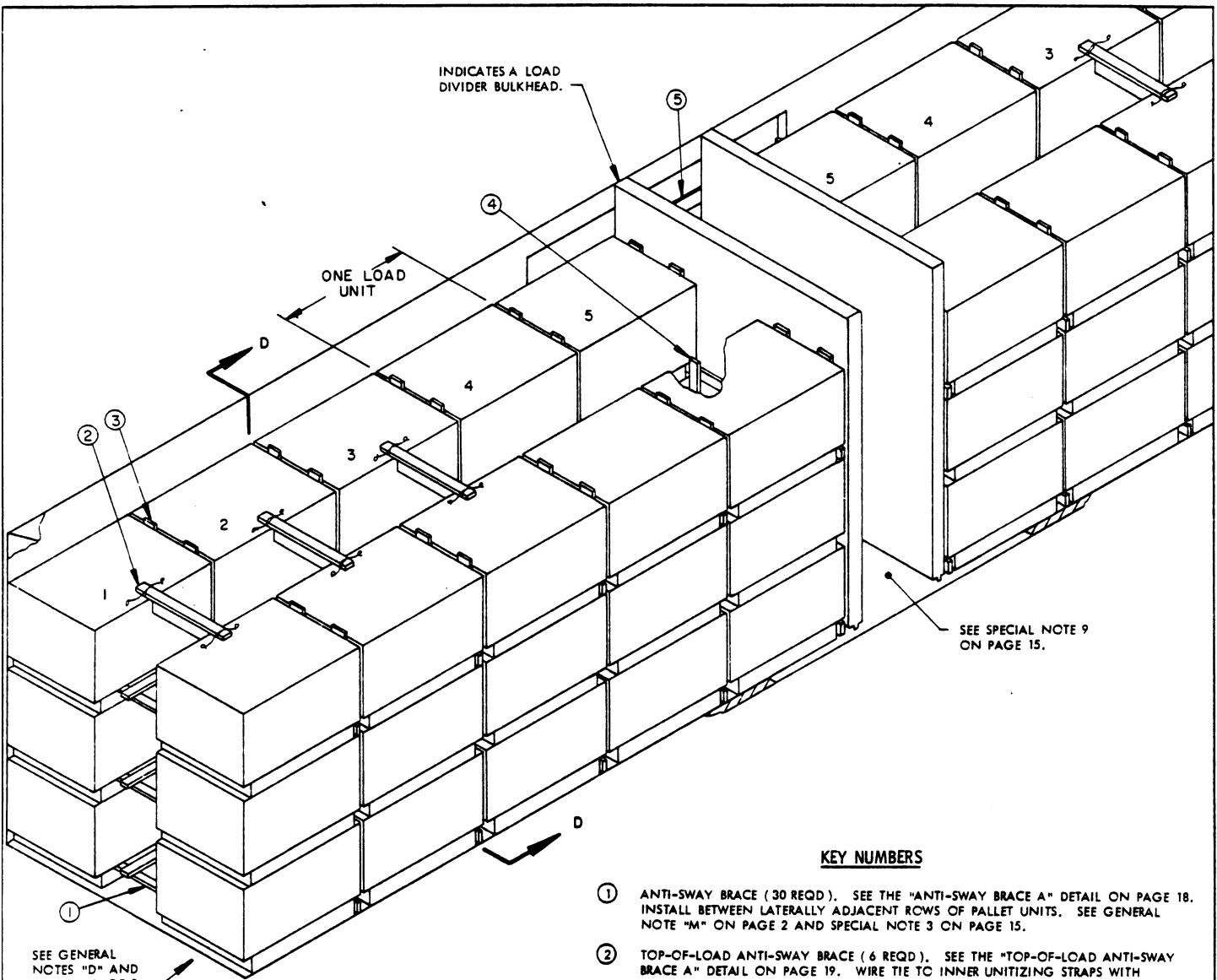

ISOMETRIC VIEW

**KEY NUMBERS**

- ① ANTI-SWAY BRACE (30 REQD). SEE THE "ANTI-SWAY BRACE A" DETAIL ON PAGE 18. INSTALL BETWEEN LATERALLY ADJACENT ROWS OF PALLET UNITS. SEE GENERAL NOTE "M" ON PAGE 2 AND SPECIAL NOTE 3 ON PAGE 15.
- ② TOP-OF-LOAD ANTI-SWAY BRACE (6 REQD). SEE THE "TOP-OF-LOAD ANTI-SWAY BRACE A" DETAIL ON PAGE 19. WIRE TIE TO INNER UNITIZING STRAPS WITH NO. 14 GAGE WIRE AS TYPICALLY SHOWN BY THE "TIE WIRE APPLICATION A" DETAIL ON PAGE 122. SEE SPECIAL NOTE 4 ON PAGE 15.
- ③ SEPARATOR GATE (10 REQD). SEE THE "SEPARATOR GATE B" DETAIL ON PAGE 17. POSITION WITH THE HORIZONTAL PIECES AGAINST THE ALREADY-LOADED UNITS. SEE SPECIAL NOTES 5 AND 7 ON PAGE 15.
- ④ STOP PIECE, 1" X 4" X 6'-6" (4 REQD). POSITION AGAINST PALLET UNITS IN THE DOORWAY AREA AND NAIL TO THE HORIZONTAL PIECES OF PIECE MARKED ③ W/3-6d NAILS AT EACH JOINT AND CLINCH. SEE SPECIAL NOTE 6 ON PAGE 15.
- ⑤ DOORWAY PROTECTION (2 REQD). SEE THE "DOORWAY PROTECTION A" DETAIL ON PAGE 18. NAIL TO THE DOOR POSTS W/12d NAILS. SEE SPECIAL NOTE 8 ON PAGE 15.

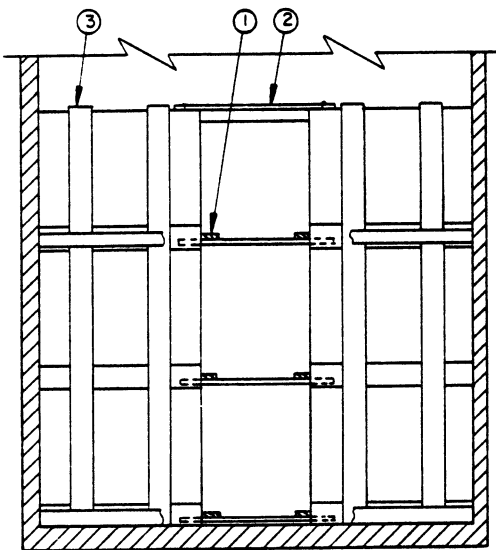

SECTION D-D

ALTERNATED CONTAINERS UNIT (BASIC HEIGHT)  
 60-UNIT LOAD IN A 50'-6" LONG BY 9'-2" WIDE BOX CAR EQUIPPED WITH LOAD DIVIDERS

( SPECIAL NOTES CONTINUED )

10. THE DEPICTED LOAD CAN BE REDUCED TO SUIT THE QUANTITY TO BE SHIPPED. A 3-TIER LOAD CAN BE REDUCED BY A MULTIPLE OF SIX ( 6 ) PALLET UNITS, OR A 2-TIER LOAD CAN BE REDUCED BY A MULTIPLE OF FOUR ( 4 ) UNITS, OR A 1-TIER LOAD CAN BE REDUCED BY A MULTIPLE OF TWO ( 2 ) UNITS BY OMITTING ONE OR MORE LOAD UNITS FROM THE CENTER PORTION OF THE LOAD. OR, THE ENTIRE ONE OR TWO TOP TIERS CAN BE OMITTED. FOR OTHER METHODS OF REDUCING A LOAD, AND FOR TYPICAL LCL PROCEDURES, REFER TO PAGES 94 THRU 105 AND GENERAL NOTE "FF" ON PAGE 3 FOR GUIDANCE.
11. IF PALLET UNITS WHICH DO NOT CONTAIN A FULL QUANTITY OF CONTAINERS ARE TO BE TRANSPORTED, REFER TO PAGE 117 AND/OR PAGES 118 AND 120 FOR SHIPPING GUIDANCE.
12. FOR SHIPMENT OF ONE OR MORE LEFTOVER CONTAINERS, SEE THE "PROCEDURES FOR SHIPMENT OF LEFTOVER CONTAINERS" ON PAGE 119 FOR GUIDANCE.

SPECIAL NOTES:

1. A 50'-6" LONG BY 9'-2" WIDE WOOD-LINED CUSHIONED BOX CAR EQUIPPED WITH LOAD DIVIDER BULKHEADS AND WITH 10'-0" WIDE DOOR OPENINGS IS SHOWN. CARS OF OTHER DIMENSIONS AND CARS HAVING NARROWER OR WIDER DOOR OPENINGS CAN BE USED. SEE GENERAL NOTES "AA" THRU "EE" ON PAGE 3.
2. THE PALLET UNIT SHOWN IN THE TYPICAL LOAD ON PAGE 14 IS THE ALTERNATED CONTAINERS UNIT ( BASIC HEIGHT ). A MAXIMUM OF SEVENTY-TWO ( 72 ) OF THESE UNITS, FOR AN APPROXIMATE LADING WEIGHT OF 117,792 POUNDS, CAN BE PLACED IN A 60'-8" LONG CAR, OR A MAXIMUM OF FORTY-EIGHT ( 48 ) UNITS CAN BE LOADED IN A 40'-6" CAR FOR AN APPROXIMATE LADING WEIGHT OF 78,528 POUNDS, WHEN USING THE DEPICTED PROCEDURES. IF CARS 9'-4" OR WIDER ARE AVAILABLE, THE CROSSWISE LOADING PATTERN SHOWN ON PAGE 10 MAY BE EMPLOYED. THEN, NINETY-SIX ( 96 ) PALLET UNITS FOR AN APPROXIMATE LADING WEIGHT OF 157,056 POUNDS CAN BE PLACED IN A 60'-8" LONG CAR, SEVENTY-EIGHT ( 78 ) UNITS CAN BE LOADED IN A 50'-6" LONG CAR FOR AN APPROXIMATE LADING WEIGHT OF 127,608 POUNDS, AND SIXTY ( 60 ) UNITS CAN BE LOADED IN A 40'-6" LONG CAR FOR AN APPROXIMATE LADING WEIGHT OF 98,160 POUNDS. IF THE "ALTERNATIVE DOORWAY PROTECTION F" PROCEDURES AS SHOWN ON PAGE 128 ARE USED IN LIEU OF THE WOODEN DOOR GATE TYPE PROTECTION, PIECE MARKED ⑤, NAILED FLOORLINE BLOCKING MUST BE USED IN LIEU OF THE LOWER ANTI-SWAY BRACES IN THE DOORWAY AREA. NAILED BLOCKING IS REQUIRED FOR ALL PALLET STACKS WHICH ARE COMPLETELY WITHIN THE DOORWAY AREA OR WHICH EXTEND INTO THE DOORWAY AREA BY ONE-HALF OR MORE OF THE STACK WIDTH ON EITHER SIDE OF THE CAR.
3. TOP-OF-LOAD ANTI-SWAY BRACES, SHOWN AS PIECES MARKED ② IN THE LOAD ON PAGE 14, MUST BE INSTALLED IN EACH END OF THE CAR AND WIRE TIED TO UNITIZING STRAPS WITH NO. 14 GAGE WIRE AS TYPICALLY SHOWN BY THE "TIE WIRE APPLICATION A" DETAIL ON PAGE 122. THREE ( 3 ) BRACES ARE REQUIRED IN EACH END OF A LOAD REGARDLESS OF THE CAR LENGTH.
4. TO FACILITATE POSITIONING OF THE PALLET UNITS AS LOADING PROGRESSES, POSITION PALLET UNIT STACKS AGAINST THE END WALL, THEN POSITION A SEPARATOR GATE SHOWN AS PIECE MARKED ③, SO THE 1" X 4" TIE PIECES ARE LOCATED UNDER THE "OVERHANG" OF THE BOTTOM AND TOP PALLET UNITS. REPEAT THIS PROCEDURE FOR THE REMAINING STACKS.
5. SEPARATOR GATES IN THE DOORWAY MUST BE PREVENTED FROM SHIFTING INTO A DOOR OPENING BY THE APPLICATION OF THE STOP PIECES, PIECES MARKED ④. IN CARS EQUIPPED WITH STAGGERED DOORS, STOP PIECES MAY BE REQUIRED ON UP TO FOUR SEPARATOR GATES.
6. SEPARATOR GATES MAY BE FORMED FROM 3/8" OR THICKER PLYWOOD IN LIEU OF DIMENSIONAL LUMBER, IF DESIRED. SEE THE "ALTERNATIVE SEPARATOR GATE" DETAIL ON PAGE 122 FOR CONSTRUCTION GUIDANCE.
7. DOORWAY PROTECTION IS REQUIRED FOR ALL PALLET UNIT STACKS WHICH ARE COMPLETELY WITHIN THE DOORWAY AREA OR WHICH EXTEND INTO THE DOORWAY AREA BY ONE-HALF OR MORE OF THE STACK WIDTH. THE WOODEN GATE TYPE OF DOORWAY PROTECTION, SHOWN AS PIECES MARKED ⑤ IN THE LOAD ON PAGE 14, IS APPLICABLE FOR BOX CARS EQUIPPED WITH CONVENTIONAL SLIDING DOORS AND NAILABLE DOOR POSTS. REFER TO PAGES 126 THRU 128 FOR ALTERNATIVE DOORWAY PROTECTION FOR CARS EQUIPPED WITH CONVENTIONAL SLIDING DOORS. IF THE CAR BEING LOADED IS EQUIPPED WITH PLUG TYPE DOORS, NAILED FLOORLINE BLOCKING AND LOAD BUNDLING STRAPS MUST BE USED. SEE THE "ALTERNATIVE DOORWAY PROTECTION F" DETAIL ON PAGE 128 FOR GUIDANCE IF THE PALLET UNITS ARE POSITIONED AS SHOWN ON PAGE 14. SEE THE "ALTERNATIVE DOORWAY PROTECTION E" DETAIL ON THAT PAGE IF THE PALLET UNITS ARE POSITIONED CROSSWISE.
8. A STRUT ASSEMBLY, SHOWN AS PIECE MARKED ⑥ IN THE LOAD ON PAGE 42, IS REQUIRED BETWEEN THE LOAD DIVIDER BULKHEADS WHEN THE LOAD IN EITHER END OF THE CAR IS 50,000 POUNDS OR MORE. FOR THE DEPICTED PALLET UNIT, A STRUT ASSEMBLY WILL BE REQUIRED IF THE LOAD IN ONE END OF THE CAR CONSISTS OF MORE THAN FIVE ( 5 ) LOAD UNITS, WHICH WOULD BE THE CASE IF AN OFFSET LOADING PATTERN IS EMPLOYED. THE STRUT ASSEMBLY WILL ALWAYS BE REQUIRED FOR FULL LOADS IN 60' OR LONGER CARS.

( CONTINUED AT LEFT )

BILL OF MATERIAL		
LUMBER	LINEAR FEET	BOARD FEET
1" X 4"	209	70
1" X 6"	480	240
2" X 3"	35	18
2" X 4"	435	290
NAILS	NO. REQD	POUNDS
6d ( 2" )	336	2
10d ( 3" )	360	5-3/4
12d ( 3-1/4" )	66	1-1/4
WIRE, NO. 14 GAGE	36' REQD	NIL

LOAD AS SHOWN

ITEM	QUANTITY	WEIGHT ( APPROX )
PALLET UNIT	60	98,160 LBS
DUNNAGE		1,245 LBS
TOTAL WEIGHT		99,405 LBS

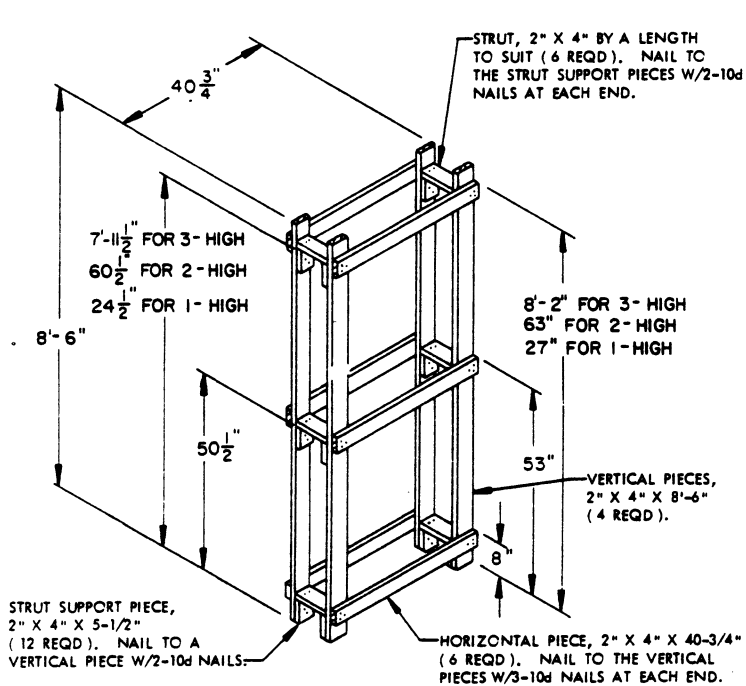

**CRIB FILL A**

CRIB FILL ASSEMBLIES "A" AND "B" SHOULD BE PRE-FABRICATED. CONSTRUCT TO BE 1/2" TO 3/4" LESS IN WIDTH THAN THE DISTANCE BETWEEN LATERALLY ADJACENT ROWS OF PALLET UNITS. OMIT THE MID-HEIGHT HORIZONTAL PIECES, STRUTS, AND STRUT SUPPORT PIECES WHEN USING CRIB FOR A 1 OR 2-HIGH LOAD.

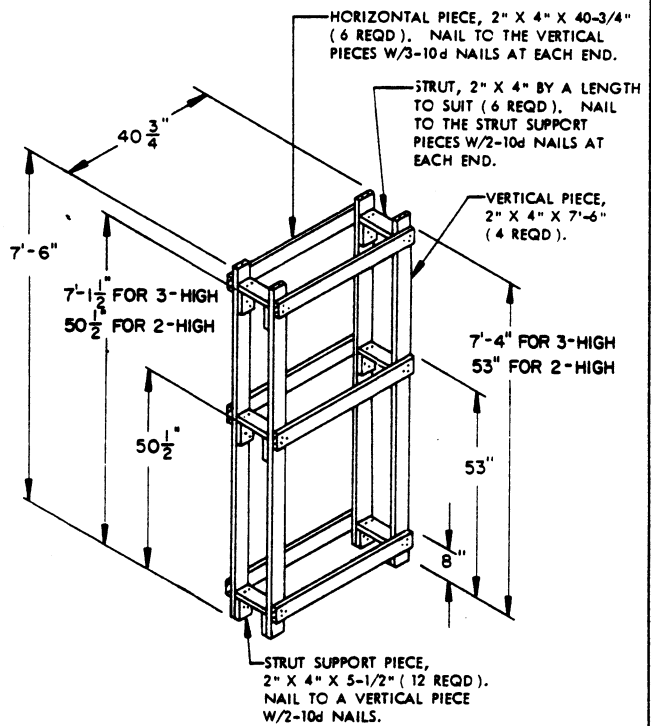

**CRIB FILL B**

OMIT THE MID-HEIGHT HORIZONTAL PIECES, STRUTS, AND STRUT SUPPORT PIECES WHEN USING CRIB FOR A 2-HIGH LOAD. CRIB FILL "B" IS NOT REQUIRED FOR A 1-HIGH LOAD; USE CRIB FILL "A" THROUGHOUT THE LENGTH OF THE LOAD.

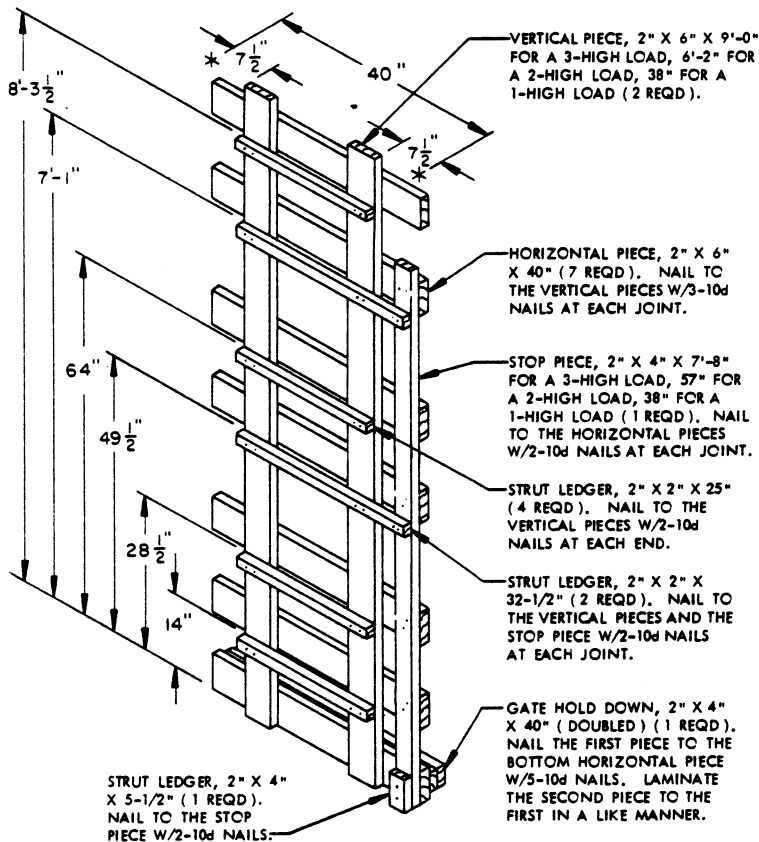

**CENTER GATE A**

1 RIGHT HAND AND 1 LEFT HAND GATE REQUIRED. NOTE THAT THE SECOND 2" X 2" STRUT LEDGER FROM THE BOTTOM MUST BE 32-1/2" LONG FOR A 1-HIGH LOAD.

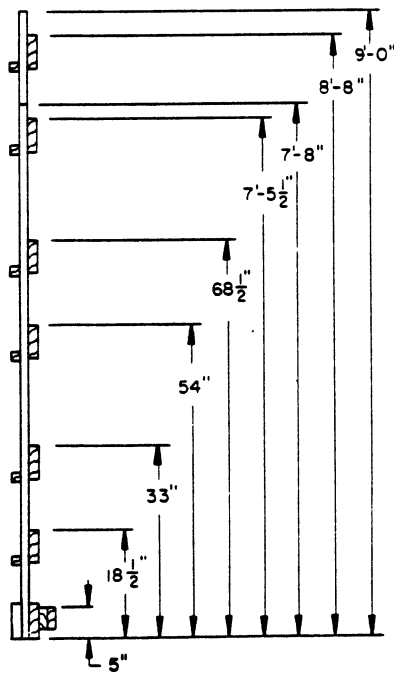

**END VIEW**



HORIZONTAL PIECE, 1" X 4" X 40" (2 REQD)  
NAIL TO THE VERTICAL PIECES AND THE STOP  
PIECE W/3-6d NAILS AT EACH JOINT AND CLINCH.

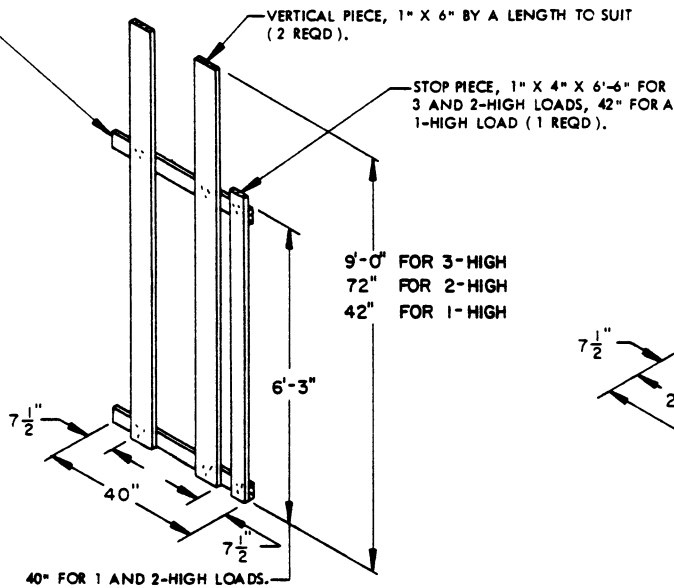

**SEPARATOR GATE A**

RIGHT HAND AND LEFT HAND GATES ARE REQUIRED. A  
RIGHT HAND GATE IS SHOWN.

HORIZONTAL PIECE, 1" X 4" BY CAR WIDTH MINUS 1/2"  
IN LENGTH (2 REQD). NAIL TO THE VERTICAL PIECES  
W/3-6d NAILS AT EACH JOINT AND CLINCH.

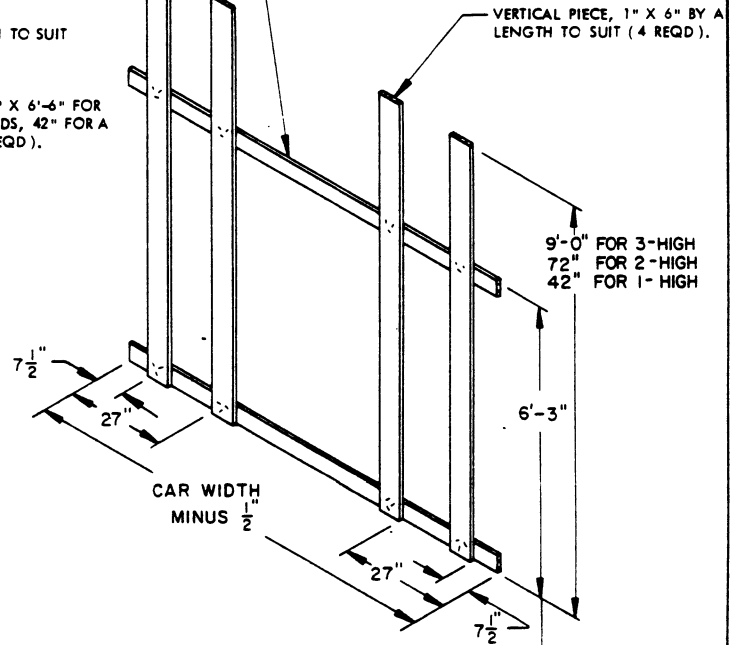

**SEPARATOR GATE B**

40" FOR 1 AND 2-  
HIGH LOADS.

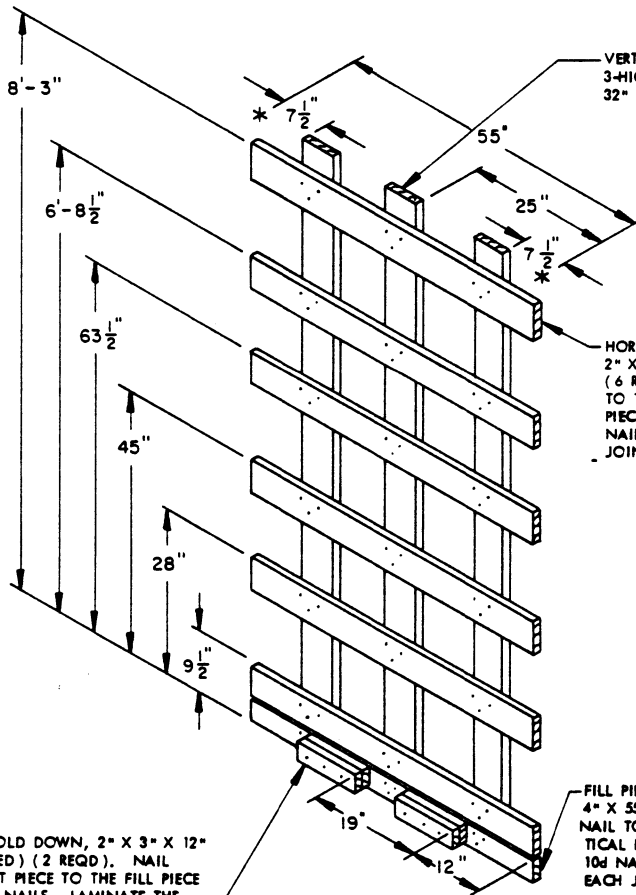

**CENTER GATE B**

GATE HOLD DOWN, 2" X 3" X 12"  
(DOUBLED) (2 REQD). NAIL  
THE FIRST PIECE TO THE FILL PIECE  
W/3-10d NAILS. LAMINATE THE  
SECOND PIECE TO THE FIRST IN A  
LIKE MANNER.

FILL PIECE, 2" X  
4" X 55" (1 REQD).  
NAIL TO THE VER-  
TICAL PIECES W/3-  
10d NAILS AT  
EACH JOINT.

STRUT LEDGER, 2" X 2" X 40" (6 REQD). NAIL  
TO THE VERTICAL PIECES W/2-10d NAILS AT  
EACH JOINT.

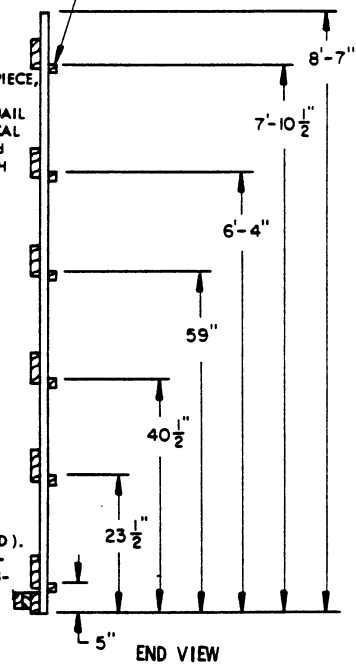

RETAINER PIECE, 2" X 4" BY A LENGTH TO SUIT (2 REQD).

FABRICATE TO FIT BETWEEN THE POSTS OF LATERALLY ADJACENT PALLETS.

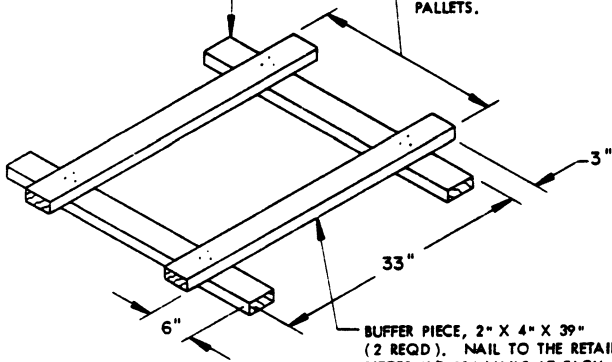

BUFFER PIECE, 2" X 4" X 39" (2 REQD). NAIL TO THE RETAINER PIECES W/3-10d NAILS AT EACH JOINT.

**ANTI-SWAY BRACE A**

IF DESIRED, THE ANTI-SWAY BRACE CAN BE PARTIALLY PRE-ASSEMBLED; ONE BUFFER PIECE CAN BE NAILED TO BOTH RETAINER PIECES. THE LONG ENDS OF THE ASSEMBLY CAN THEN BE INSTALLED INTO THE FORKLIFT OPENING OF A LOADED PALLET PRIOR TO POSITIONING THE LATERALLY ADJACENT PALLET.

HORIZONTAL PIECE, 1" X 6" BY DOOR OPENING WIDTH (6 REQD). NAIL TO THE VERTICAL PIECES W/3-6d NAILS AT EACH END.

DOOR OPENING WIDTH

8'-8"

7'-5 1/2"

68 1/2"

54"

33"

18 1/2"

VERTICAL PIECE, 2" X 3" X 8'-8" (2 REQD). NAIL TO A DOOR POST W/12d NAILS.

**DOORWAY PROTECTION A**

VERTICAL PIECE, 2" X 6" X 9'-0" FOR A 3-HIGH LOAD, 6'-2" FOR A 2-HIGH LOAD, 38" FOR A 1-HIGH LOAD (4 REQD).

CAR WIDTH MINUS 1/2"

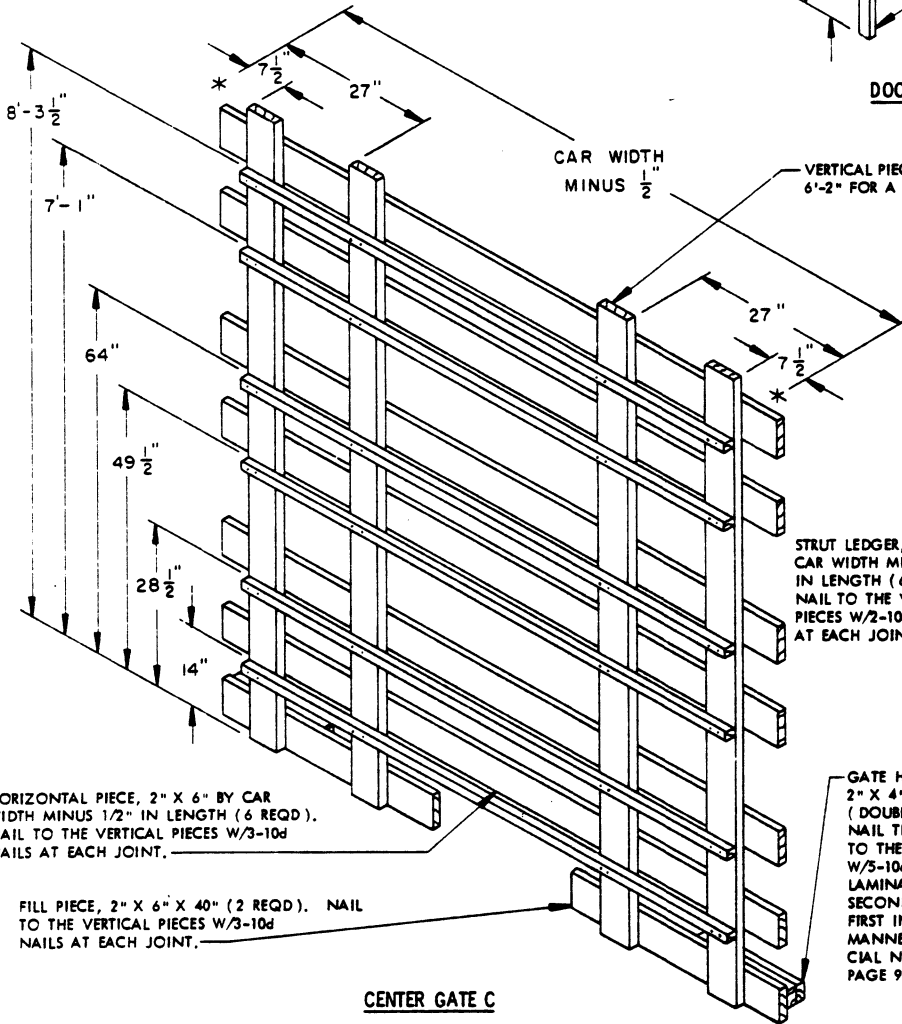

HORIZONTAL PIECE, 2" X 6" BY CAR WIDTH MINUS 1/2" IN LENGTH (6 REQD). NAIL TO THE VERTICAL PIECES W/3-10d NAILS AT EACH JOINT.

FILL PIECE, 2" X 6" X 40" (2 REQD). NAIL TO THE VERTICAL PIECES W/3-10d NAILS AT EACH JOINT.

**CENTER GATE C**

STRUT LEDGER, 2" X 2" BY CAR WIDTH MINUS 15-1/2" IN LENGTH (6 REQD). NAIL TO THE VERTICAL PIECES W/2-10d NAILS AT EACH JOINT.

GATE HOLD DOWN, 2" X 4" X 18" (DOUBLED) (2 REQD). NAIL THE FIRST PIECE TO THE FILL PIECE W/5-10d NAILS, LAMINATE THE SECOND PIECE TO THE FIRST IN A LIKE MANNER. SEE SPECIAL NOTE 11 ON PAGE 9.

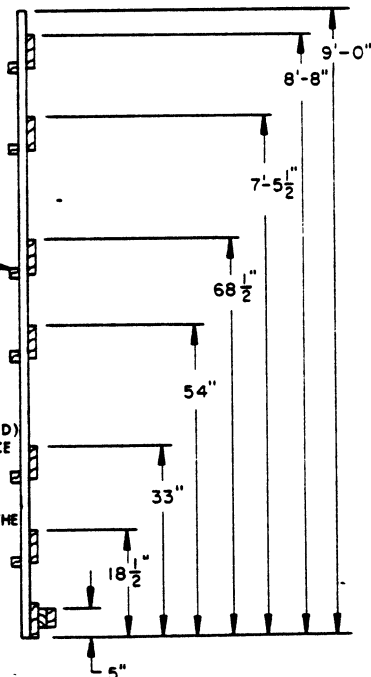

**END VIEW**

SUPPORT PIECE, 2" X 4" BY A LENGTH TO SUIT (1 REQD). NAIL TO THE SPACER PIECE W/3-12d NAILS.

SPACER PIECE, 2" X 4" BY CUT TO FIT BETWEEN LATERALLY ADJACENT PALLET UNITS MINUS 1/4" (1 REQD). POSITION SO AS TO BE CENTERED UNDER THE SUPPORT PIECE. SEE THE "END VIEW" BELOW.

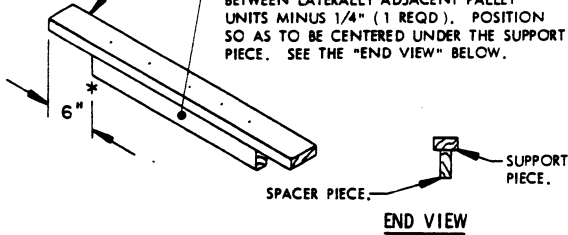

**TOP-OF-LOAD ANTI-SWAY BRACE A**

HORIZONTAL PIECE, 1" X 6" BY DOOR OPENING WIDTH (6 REQD). NAIL TO THE VERTICAL PIECES W/3-6d NAILS AT EACH END.

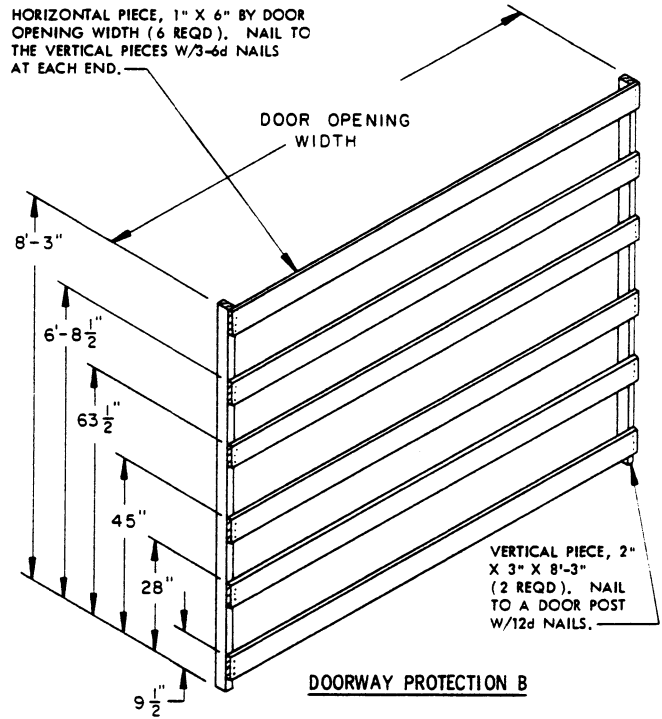

**DOORWAY PROTECTION B**

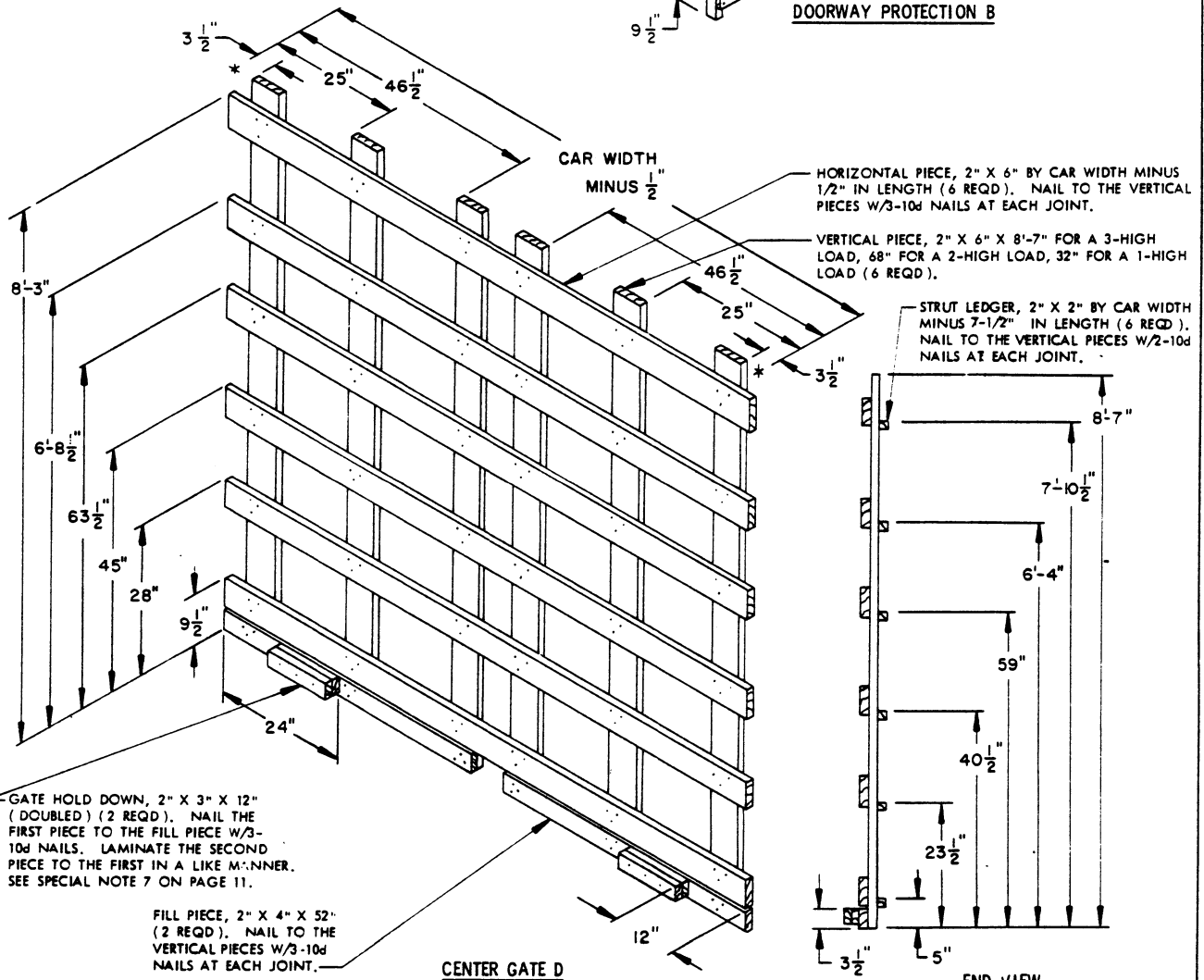

**CENTER GATE D**

**END VIEW**

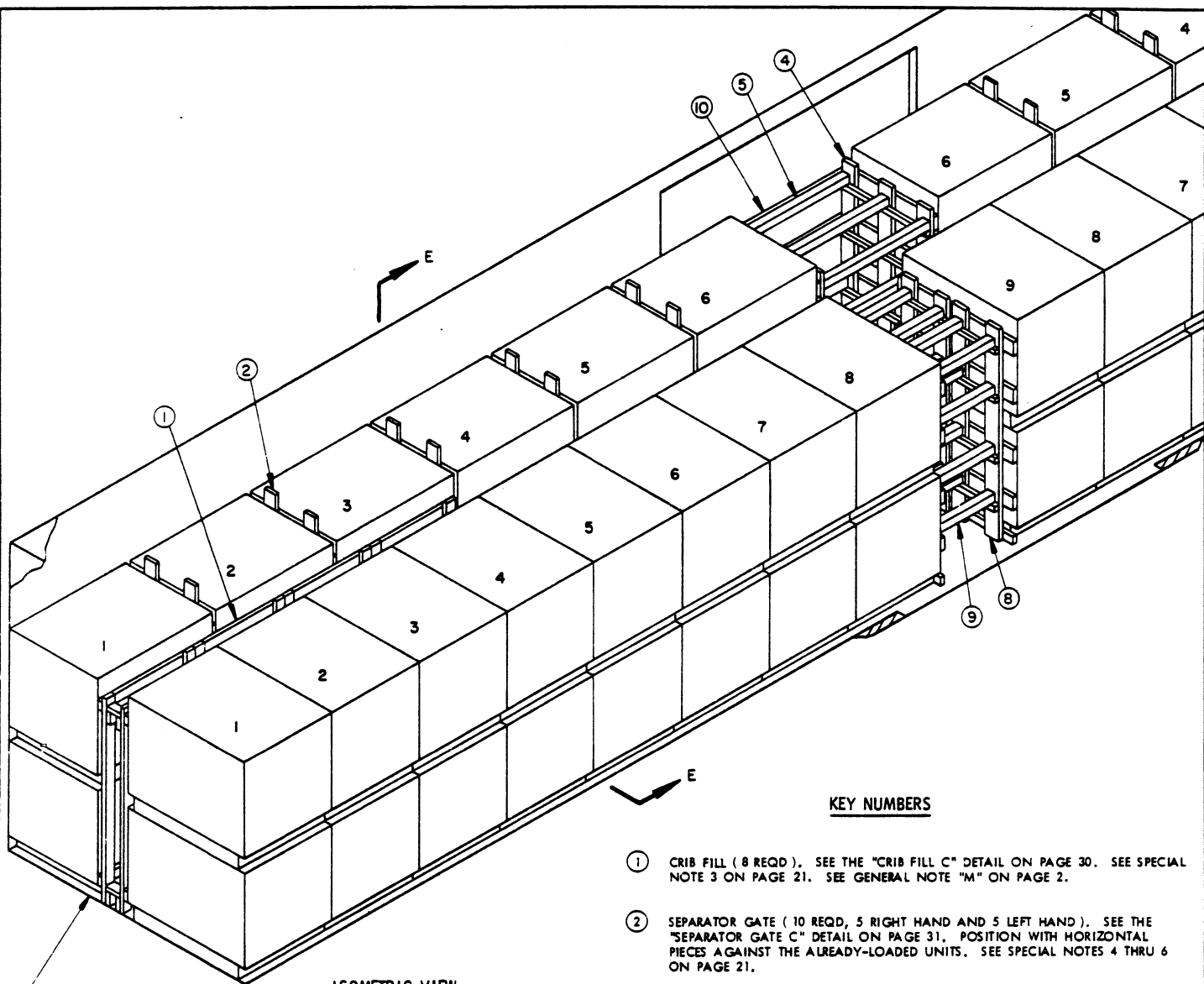

**ISOMETRIC VIEW**

SEE GENERAL NOTE "G" ON PAGE 2.

**KEY NUMBERS**

- ① CRIB FILL (8 REQD). SEE THE "CRIB FILL C" DETAIL ON PAGE 30. SEE SPECIAL NOTE 3 ON PAGE 21. SEE GENERAL NOTE "M" ON PAGE 2.
- ② SEPARATOR GATE (10 REQD, 5 RIGHT HAND AND 5 LEFT HAND). SEE THE "SEPARATOR GATE C" DETAIL ON PAGE 31. POSITION WITH HORIZONTAL PIECES AGAINST THE ALREADY-LOADED UNITS. SEE SPECIAL NOTES 4 THRU 6 ON PAGE 21.
- ③ CRIB FILL (9 REQD). SEE THE "CRIB FILL D" DETAIL ON PAGE 30.
- ④ CENTER GATE (2 REQD). SEE "CENTER GATE E" DETAIL ON PAGE 30. SEE SPECIAL NOTE 7 ON PAGE 21.
- ⑤ STRUT, 4" X 4" BY CUT TO FIT (REF: 48") (12 REQD). TOENAIL TO PIECES MARKED ④ W/2-16d NAILS AT EACH END. SEE GENERAL NOTES "L", "S", AND "T" ON PAGE 2.
- ⑥ SIDE BLOCKING FOR CENTER GATE "E", 2" X 4" X 18" (DOUBLED) (1 REQD). NAIL THE FIRST PIECE TO THE CAR FLOOR W/4-16d NAILS. NAIL THE SECOND PIECE TO THE FIRST IN A LIKE MANNER. SEE THE "PARTIAL PLAN VIEW" ON PAGE 21.
- ⑦ CRIB FILL RETAINER, 2" X 4" BY A LENGTH TO SUIT (REF: 48") (2 REQD). POSITION TO SPAN THE STRUTS OF LONGITUDINALLY ADJACENT CRIB FILL "D" ASSEMBLIES AT THE CENTER OF THE CAR AND NAIL TO EACH STRUT W/3-10d NAILS. SEE THE "PARTIAL PLAN VIEW" ON PAGE 21.
- ⑧ CENTER GATE (2 REQD). SEE "CENTER GATE "F" DETAIL ON PAGE 31.
- ⑨ STRUT, 4" X 4" BY CUT TO FIT (REF: 29") (16 REQD). TOENAIL TO PIECES MARKED ⑧ W/2-16d NAILS AT EACH END.
- ⑩ DOORWAY PROTECTION (2 REQD). SEE THE "DOORWAY PROTECTION C" DETAIL ON PAGE 32. NAIL TO THE DOOR POSTS W/12d NAILS. SEE SPECIAL NOTE 8 ON PAGE 21.

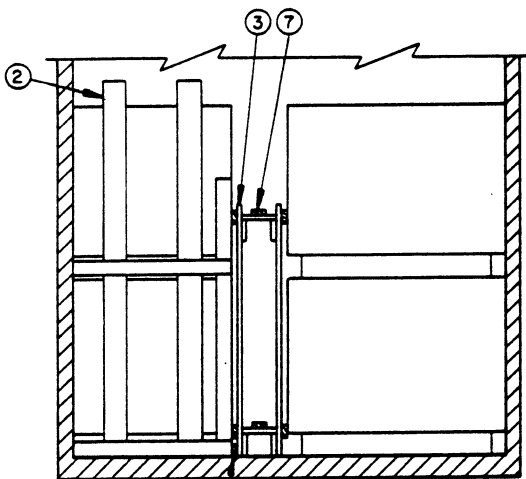

**SECTION E-E**

**ALTERNATED CONTAINERS UNIT ( INCREASED HEIGHT )  
58-UNIT LOAD IN A 60'-8" LONG BY 9'-2" WIDE CONVENTIONAL BOX CAR**

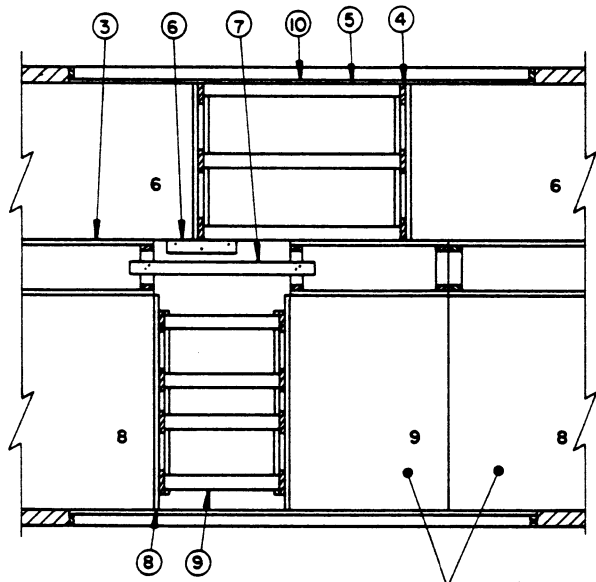

**PARTIAL PLAN VIEW**

IF THE CAR BEING LOADED IS EQUIPPED WITH PLUG TYPE DOORS, SEE SPECIAL NOTE 8 AT RIGHT.

**SPECIAL NOTES:**

1. A 60'-8" LONG BY 9'-2" WIDE WOOD-LINED CONVENTIONAL TYPE BOX-CAR EQUIPPED WITH 10'-0" WIDE DOOR OPENINGS IS SHOWN. CARS OF OTHER DIMENSIONS AND CARS HAVING WIDER OR NARROWER DOOR OPENINGS CAN BE USED. SEE GENERAL NOTE "D" ON PAGE 2.
2. THE PALLET UNIT SHOWN IN THE TYPICAL LOAD ON PAGE 20 IS THE ALTERNATED CONTAINER UNIT (INCREASED HEIGHT). A MAXIMUM OF FORTY-EIGHT (48) OF THESE UNITS, FOR AN APPROXIMATE LADING WEIGHT OF 103,104 POUNDS, CAN BE PLACED IN A 50'-6" LONG CAR WHEN USING THE DEPICTED PROCEDURES; THIRTY-EIGHT (38) UNITS; FOR A LADING WEIGHT OF 81,624 POUNDS, CAN BE OUTLOADED IN A 40'-6" LONG CAR.
3. THE "HIGH" CRIB, SHOWN AS PIECE MARKED ①, MUST BE INSTALLED IN EACH END OF THE LOAD. FOUR (4) ASSEMBLIES ARE REQUIRED IN EACH END OF A LOAD REGARDLESS OF THE CAR LENGTH.
4. THE SEPARATOR GATES, SHOWN AS PIECES MARKED ②, IN THE LOAD ON PAGE 20, ARE DESIGNATED "RIGHT HAND" AND "LEFT HAND" TO FACILITATE POSITIONING OF THE PALLET UNITS AS LOADING PROGRESSES. WHEN LOADING THE CAR, POSITION A PALLET UNIT STACK AGAINST THE END WALL, THEN POSITION A SEPARATOR GATE SO THE 1" X 4" TIE PIECES ARE LOCATED UNDER THE "OVERHANG" OF THE PALLET UNITS IN THE FIRST STACK. REPEAT THIS PROCEDURE FOR THE REMAINING STACKS.
5. ALL SEPARATOR GATES, PIECES MARKED ②, WHICH ARE WITHIN THE DOORWAY AREA OF A CAR EQUIPPED WITH CONVENTIONAL SLIDING DOORS MUST BE WIRE TIED TO THE ADJACENT CRIB FILL TO PREVENT DISPLACEMENT. ENCIRCLE THE STOP PIECE OF THE SEPARATOR GATE AND THE UPPER HORIZONTAL PIECE OF THE CRIB FILL WITH NO. 14 GAGE WIRE AND TWIST TAUT.
6. SEPARATOR GATES MAY BE FORMED FROM 3/8" OR THICKER PLYWOOD IN LIEU OF DIMENSIONAL LUMBER, IF DESIRED. CONSTRUCT EACH GATE 40-3/4" WIDE BY 8'-0" LONG.
7. CENTER GATES "E" AND "F" MAY BE PARTIALLY FORMED FROM 1/2" OR THICKER PLYWOOD, IF DESIRED. PLYWOOD MAY BE USED IN LIEU OF THE 2" X 6" HORIZONTAL PIECES. SEE THE "PLYWOOD CENTER GATE ALTERNATIVE" DETAIL ON PAGE 123 FOR GUIDANCE.
8. DOORWAY PROTECTION IS REQUIRED FOR ALL PALLET UNIT STACKS WHICH ARE COMPLETELY WITHIN THE DOORWAY AREA OR WHICH EXTEND INTO THE DOORWAY AREA BY ONE-HALF OR MORE OF THE STACK WIDTH OR LENGTH. THE WOODEN GATE TYPE OF DOORWAY PROTECTION, SHOWN AS PIECES MARKED ⑩ IN THE LOAD ON PAGE 20, IS APPLICABLE FOR BOXCARS EQUIPPED WITH CONVENTIONAL SLIDING DOORS AND NAILABLE DOOR POSTS. REFER TO PAGE 126 THRU 128 FOR ALTERNATIVE DOORWAY PROTECTION FOR CARS EQUIPPED WITH CONVENTIONAL SLIDING DOORS. IF THE CAR BEING LOADED IS EQUIPPED WITH PLUG TYPE DOORS, NAILED FLOORLINE BLOCKING AND LOAD-BUNDLING STRAPS MUST BE USED. SEE THE "ALTERNATIVE DOORWAY PROTECTION E" AND "ALTERNATIVE DOORWAY PROTECTION F" DETAILS ON PAGE 128 FOR GUIDANCE; A COMBINATION OF THE TWO METHODS MUST BE USED. NAILED SIDE BLOCKING WILL BE USED UNDER THE CRIB FILL SHOWN IN THE DOORWAY AREA OF THE LOAD. POSITION DOUBLED 2" X 4" X 48" PIECES AGAINST THE LENGTHWISE STACK NUMBERED 6, AND PRE-POSITION DOUBLED 2" X 4" X 7'-0" PIECES (APPROXIMATELY 52" FROM THE NEAR SIDE CAR WALL) SO AS TO BE AGAINST THE CROSS WISE STACKS NUMBERED 8 AND 9. THESE PIECES WILL BE USED IN LIEU OF THE 40" AND 48" LONG PIECES SHOWN BY THE ALTERNATIVE DETAILS. A SPACER ASSEMBLY, AS SHOWN IN THE "ALTERNATIVE DOORWAY PROTECTION F" DETAIL, MUST BE MODIFIED FOR USE BY CHANGING THE END WHICH EXTENDS OVER THE CROSS WISE CONTAINERS TO BE LIKE THE NEAR END OF THE STRAPPING BOARD SHOWN IN THE "ALTERNATIVE DOORWAY PROTECTION E" DETAIL. A 2" X 4" X 40" DOUBLED BATTEN AS SHOWN IN THAT VIEW IS ALSO REQUIRED. NOTE THAT THE VERTICAL PIECES AND BOTTOM SUPPORT PIECES OF THE CRIB FILL, PIECES MARKED ③, MUST HAVE THREE INCHES (3") CUT OFF THE BOTTOM END OF ONE SIDE SO THE CRIB WILL REST EVENLY ON THE NAILED SIDE BLOCKING WHICH IS ADJACENT TO THE LENGTHWISE UNITS. ALSO NOTE THAT THE CENTER GATES "E" MUST BE WIRE TIED TO PIECE MARKED ⑦ OR THE ADJACENT CRIB FILL, AS APPLICABLE, TO PREVENT DISPLACEMENT.
9. THE DEPICTED LOAD CAN BE REDUCED TO SUIT THE QUANTITY TO BE SHIPPED. A 2-TIER LOAD CAN BE REDUCED BY ONE PALLET UNIT BY EMPLOYING THE PROCEDURES ON PAGE 96. TWO (2) PALLET UNITS CAN BE OMITTED BY LEAVING OUT CROSSWISE STACK NO. 9 AND THE ADJACENT CRIB FILL. NOTE THAT STRUT BRACING MUST BE APPLIED TO THE STRUTS, PIECES MARKED ④, AND AN ADDITIONAL PIECE MARKED ④ WILL BE REQUIRED FOR THE OTHER CENTER GATE MARKED ④. OR, THE ENTIRE TOP TIER CAN BE OMITTED. A PARTIAL 1-TIER LOAD CAN BE SHIPPED IN ONE OR BOTH ENDS OF A CAR BY USING KNEE BRACES AS SHOWN ON PAGES 112 AND 113.
10. IF PALLET UNITS WHICH DO NOT CONTAIN A FULL QUANTITY OF CONTAINERS ARE TO BE TRANSPORTED, REFER TO PAGE 117 FOR SHIPPING GUIDANCE FOR LENGTHWISE UNITS AND PAGES 118 AND 120 FOR CROSSWISE UNITS.
11. FOR SHIPMENT OF ONE OR MORE LEFTOVER CONTAINERS, SEE THE "PROCEDURES FOR SHIPMENT OF LEFTOVER CONTAINERS" ON PAGE 119 FOR GUIDANCE.

**BILL OF MATERIAL**

LUMBER	LINEAR FEET	BOARD FEET
1" X 4"	137	46
1" X 6"	224	112
2" X 2"	57	19
2" X 3"	36	18
2" X 4"	791	528
2" X 6"	172	172
4" X 4"	89	119
NAILS	NO. REQD	POUNDS
6d (2")	228	1-1/2
10d (3")	1330	20-1/2
12d (3-1/4")	28	1/2
16d (3-1/2")	120	2-3/4

**LOAD AS SHOWN**

ITEM	QUANTITY	WEIGHT (APPROX)
PALLET UNIT	58	124,584 LBS
DUNNAGE		2,054 LBS
TOTAL WEIGHT		126,638 LBS

ALTERNATED CONTAINERS UNIT (INCREASED HEIGHT)  
58-UNIT LOAD IN A 60'-8" LONG BY 9'-2" WIDE CONVENTIONAL BOX CAR

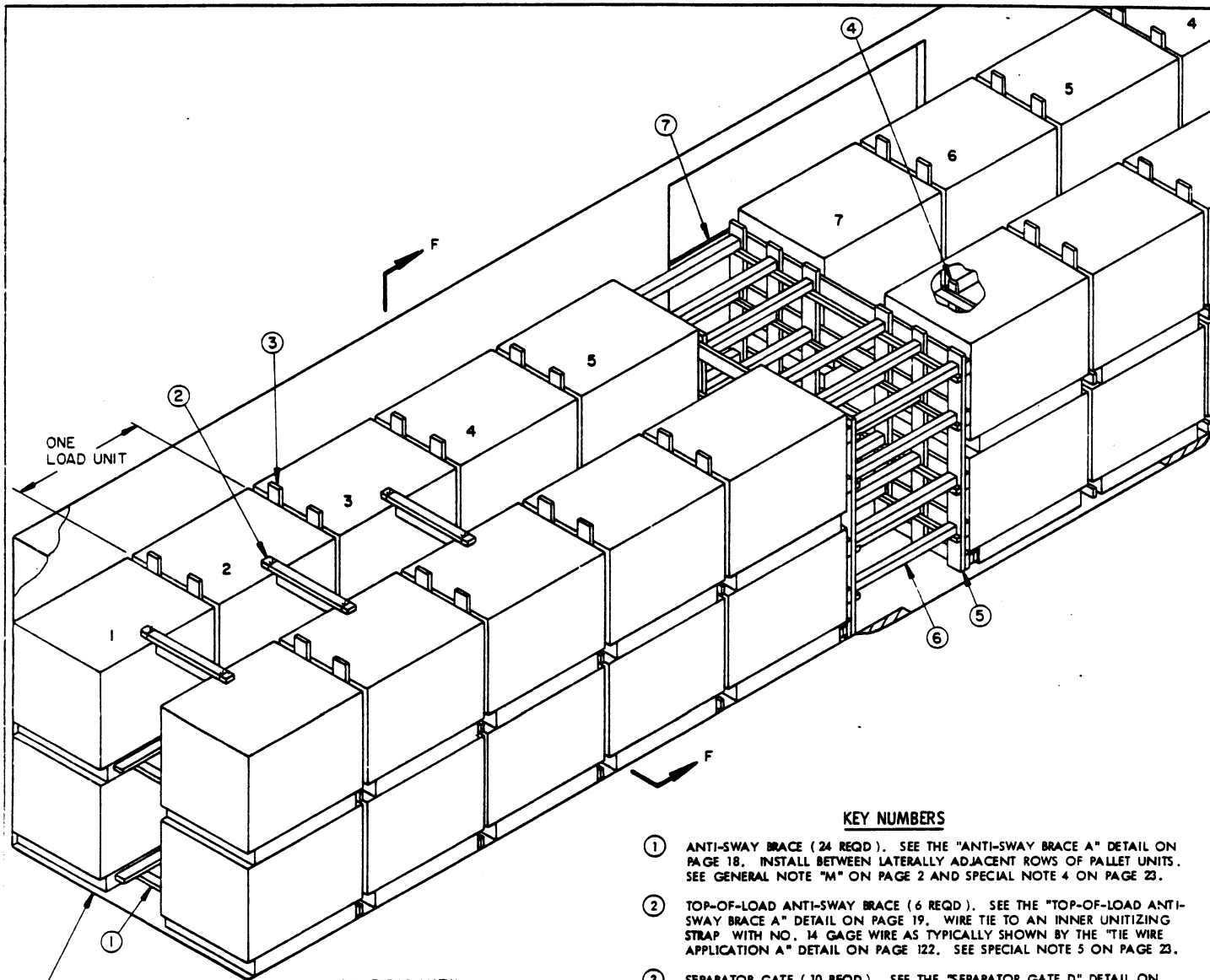

ISOMETRIC VIEW

SEE GENERAL NOTE "G" ON PAGE 2.

**KEY NUMBERS**

- ① ANTI-SWAY BRACE (24 REQD). SEE THE "ANTI-SWAY BRACE A" DETAIL ON PAGE 18. INSTALL BETWEEN LATERALLY ADJACENT ROWS OF PALLET UNITS. SEE GENERAL NOTE "M" ON PAGE 2 AND SPECIAL NOTE 4 ON PAGE 23.
- ② TOP-OF-LOAD ANTI-SWAY BRACE (6 REQD). SEE THE "TOP-OF-LOAD ANTI-SWAY BRACE A" DETAIL ON PAGE 19. WIRE TIE TO AN INNER UNITIZING STRAP WITH NO. 14 GAGE WIRE AS TYPICALLY SHOWN BY THE "TIE WIRE APPLICATION A" DETAIL ON PAGE 122. SEE SPECIAL NOTE 5 ON PAGE 23.
- ③ SEPARATOR GATE (10 REQD). SEE THE "SEPARATOR GATE D" DETAIL ON PAGE 31. POSITION WITH THE HORIZONTAL PIECES AGAINST THE ALREADY-LOADED UNITS. SEE SPECIAL NOTES 6 AND 8 ON PAGE 23.
- ④ STOP PIECE, 1" X 4" X 52" (2 REQD). INSTALL ON THE SIDE OPPOSITE THE VERTICAL PIECES OF THE SEPARATOR GATE, PIECE MARKED ③, WHICH IS IN THE DOORWAY AREA. POSITION IN CONTACT WITH THE ADJACENT PALLET UNITS AND NAIL TO THE HORIZONTAL PIECES W/3-6d NAILS AT EACH JOINT AND CLINCH. SEE SPECIAL NOTE 7 ON PAGE 23.
- ⑤ CENTER GATE (2 REQD). SEE THE "CENTER GATE G" DETAIL ON PAGE 32. SEE SPECIAL NOTES 9, 10, AND 13 ON PAGE 23.
- ⑥ STRUT, 4" X 4" BY CUT TO FIT (REF. 48") (24 REQD). TOENAIL TO PIECES MARKED ④ W/2-16d NAILS AT EACH END. SEE GENERAL NOTES "L", "S", AND "T" ON PAGE 2.
- ⑦ DOORWAY PROTECTION (2 REQD). SEE THE "DOORWAY PROTECTION C" DETAIL ON PAGE 32. NAIL TO THE DOOR POSTS W/12d NAILS. SEE SPECIAL NOTE 12 ON PAGE 23.

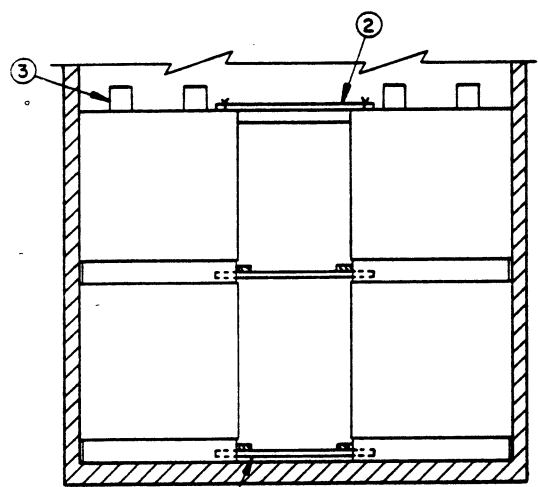

SECTION F-F

ALTERNATED CONTAINERS UNIT ( INCREASED HEIGHT )  
 48-UNIT LOAD IN A 60'-8" LONG BY 9'-2" WIDE CONVENTIONAL BOX CAR

(SPECIAL NOTES CONTINUED)

- 14. THE DEPICTED LOAD CAN BE REDUCED TO SUIT THE QUANTITY TO BE SHIPPED. A 2-TIER LOAD CAN BE REDUCED BY A MULTIPLE OF FOUR (4) PALLET UNITS OR A 1-TIER LOAD CAN BE REDUCED BY A MULTIPLE OF TWO (2) UNITS BY OMITTING ONE OR MORE LOAD UNITS FROM THE CENTER PORTION OF THE LOAD. OR, THE ENTIRE TOP TIER CAN BE OMITTED. FOR OTHER METHODS OF REDUCING A LOAD, AND FOR TYPICAL LCL PROCEDURES, REFER TO PAGES 92 THRU 120 FOR GUIDANCE.
- 15. IF PALLET UNITS WHICH DO NOT CONTAIN A FULL QUANTITY OF CONTAINERS ARE TO BE TRANSPORTED, REFER TO PAGE 117 FOR SHIPPING GUIDANCE.
- 16. FOR SHIPMENT OF ONE OR MORE LEFTOVER CONTAINERS, SEE THE "PROCEDURES FOR SHIPMENT OF LEFTOVER CONTAINERS" ON PAGE 119 FOR GUIDANCE.

SPECIAL NOTES:

- 1. A 60'-8" LONG BY 9'-2" WIDE WOOD-LINED CONVENTIONAL TYPE BOXCAR EQUIPPED WITH 10'-0" WIDE DOOR OPENINGS IS SHOWN. CARS OF OTHER DIMENSIONS AND CARS HAVING WIDER OR NARROWER DOOR OPENINGS CAN BE USED. SEE GENERAL NOTE "D" ON PAGE 2 AND SPECIAL NOTE 3 BELOW.
- 2. THE PALLETIZED UNIT SHOWN IN THE TYPICAL LOAD ON PAGE 22 IS THE ALTERNATED CONTAINER UNIT (INCREASED HEIGHT). A MAXIMUM OF FORTY (40) OF THESE UNITS, FOR AN APPROXIMATE LADING WEIGHT OF 85,920 POUNDS, CAN BE PLACED IN A 50'-6" LONG CAR WHEN USING THE DEPICTED PROCEDURES; THIRTY-TWO (32) UNITS, FOR AN APPROXIMATE WEIGHT OF 68,736 POUNDS, CAN BE OUTLOADED IN A 40'-6" LONG CAR.
- 3. THE DEPICTED LOADING PATTERN IS ADEQUATE FOR CARS HAVING DOOR OPENINGS 8' THRU 10' OR WIDER. IF THE CAR TO BE LOADED HAS DOOR OPENINGS LESS THAN 8'-0" WIDE AND NOT OF SUFFICIENT HEIGHT TO ALLOW PERSONNEL TO EXIT THE CAR OVER THE TOP OF THE LOAD WHEN NECESSARY, THE PALLETS SHOULD BE POSITIONED SO THERE ARE SIX (6) LOAD UNITS IN EACH END. NOTE THAT ALTHOUGH CARS HAVING DOOR OPENINGS AS NARROW AS 6'-0" WIDE CAN BE USED FOR FULL LOADS, LOADING IS PROGRESSIVELY MORE DIFFICULT AS THE WIDTH OF THE DOOR OPENING DECREASES.
- 4. IF THE "ALTERNATIVE DOORWAY PROTECTION F" PROCEDURES AS SHOWN ON PAGE 128 ARE USED IN LIEU OF THE WOODEN DOOR GATE TYPE PROTECTION, PIECE MARKED ⑦, NAILED FLOORLINE BLOCKING MUST BE USED IN LIEU OF EACH LOWER ANTI-SWAY BRACE IN THE DOORWAY AREA. NAILED BLOCKING IS REQUIRED FOR ALL PALLET STACKS WHICH ARE COMPLETELY WITHIN THE DOORWAY AREA OR WHICH EXTEND INTO THE DOORWAY AREA BY ONE-HALF OR MORE OF THE STACK WIDTH ON EITHER SIDE OF THE CAR. SEE SPECIAL NOTE 12.
- 5. TOP-OF-LOAD ANTI-SWAY BRACES, SHOWN AS PIECES MARKED ② IN THE LOAD ON PAGE 22, MUST BE INSTALLED IN EACH END OF THE CAR AND WIRE TIED TO A UNITIZING STRAP WITH NO. 14 GAGE WIRE AS TYPICALLY SHOWN BY THE "TIE WIRE APPLICATION A" DETAIL ON PAGE 122. THREE (3) BRACES ARE REQUIRED IN EACH END OF A LOAD REGARDLESS OF THE CAR LENGTH.
- 6. TO FACILITATE POSITIONING OF THE PALLET UNITS AS LOADING PROGRESSES, WHEN LOADING THE BOXCAR, POSITION PALLET UNIT STACKS AGAINST THE END WALL, THEN POSITION A SEPARATOR GATE, SHOWN AS PIECE MARKED ③ SO THE 1" X 4" TIE PIECES ARE LOCATED UNDER THE "OVERHANG" OF THE PALLET UNITS. REPEAT THIS PROCEDURE FOR THE REMAINING STACKS.
- 7. SEPARATOR GATES IN THE DOORWAY MUST BE PREVENTED FROM SHIFTING INTO A DOOR OPENING BY THE APPLICATION OF THE STOP PIECES, PIECES MARKED ④. IN CARS EQUIPPED WITH STAGGERED DOORS, STOP PIECES MAY BE REQUIRED ON UP TO FOUR SEPARATOR GATES.
- 8. SEPARATOR GATES MAY BE FORMED FROM 3/8" OR THICKER PLYWOOD IN LIEU OF DIMENSIONAL LUMBER, IF DESIRED. SEE THE "ALTERNATIVE SEPARATOR GATE" DETAIL ON PAGE 122 FOR CONSTRUCTION GUIDANCE.
- 9. CENTER GATE "G" MAY BE PARTIALLY FORMED FROM 1/2" OR THICKER PLYWOOD, IF DESIRED. PLYWOOD MAY BE USED IN LIEU OF THE 2" X 6" HORIZONTAL PIECES. SEE THE "PLYWOOD CENTER GATE ALTERNATIVE" DETAIL ON PAGE 123 FOR GUIDANCE.
- 10. FOR EASE OF HANDLING, SPLIT CENTER GATES, WHICH ARE NOT DEPENDENT UPON THE WIDTH OF THE CAR, MAY BE USED AS AN ALTERNATIVE TO THE CAR WIDTH GATES. IN LIEU OF EACH "CENTER GATE G", SHOWN AS PIECE MARKED ⑤ IN THE LOAD ON PAGE 22, INSTALL TWO (2) "CENTER GATES E" AS SHOWN ON PAGE 30. AFTER THE SPLIT GATES AND STRUTS HAVE BEEN INSTALLED, THE SPLIT GATES MUST BE TIED TOGETHER AS DEPICTED BY THE "TIE PIECE APPLICATION" DETAIL ON PAGE 123.
- 11. DOOR SPANNER TYPE GATE HOLD DOWN MAY BE USED IN LIEU OF THE DOUBLED 2" X 4" MATERIAL NAILED TO CENTER GATE G, PROVIDING THE CAR BEING LOADED HAS NAILED SIDEWALLS. SEE THE DETAILS ON PAGE 125 FOR GUIDANCE.
- 12. DOORWAY PROTECTION IS REQUIRED FOR ALL PALLET UNIT STACKS WHICH ARE COMPLETELY WITHIN THE DOORWAY AREA OR WHICH EXTEND INTO THE DOORWAY AREA BY ONE-HALF OR MORE OF THE STACK WIDTH. THE WOODEN GATE TYPE OF DOORWAY PROTECTION, SHOWN AS PIECE MARKED ⑦ IN THE LOAD ON PAGE 22, IS APPLICABLE FOR BOXCARS EQUIPPED WITH CONVENTIONAL SLIDING DOORS AND NAILED DOOR POSTS. REFER TO PAGES 126 THRU 128 FOR ALTERNATIVE DOORWAY PROTECTION FOR CARS EQUIPPED WITH CONVENTIONAL SLIDING DOORS. IF THE CAR BEING LOADED IS EQUIPPED WITH PLUG TYPE DOORS, NAILED FLOORLINE BLOCKING AND LOAD BUNDLING STRAPS MUST BE USED. SEE THE "ALTERNATIVE DOORWAY PROTECTION F" DETAIL ON PAGE 128 FOR GUIDANCE.
- 13. IF THE ALTERNATIVE DOORWAY PROTECTION "F" PROCEDURES SHOWN ON PAGE 128 ARE USED IN LIEU OF THE WOODEN DOORWAY PROTECTION, PIECES MARKED ⑦, THE CENTER GATES MUST BE RESTRAINED FROM LATERAL MOVEMENT. THIS CAN BE ACCOMPLISHED BY NAILING TO THE CAR FLOOR A DOUBLED 2" X 4" X 18" PIECE POSITIONED LONGITUDINALLY SO AS TO BE CENTERED AGAINST THE FILL PIECE OF A CENTER GATE. TWO (2) PIECES WILL BE REQUIRED FOR EACH CENTER GATE WHICH IS IN THE DOOR OPENING OR WITHIN SIX INCHES (6") OF BEING IN THE DOOR OPENING.

(CONTINUED AT LEFT)

BILL OF MATERIAL		
LUMBER	LINEAR FEET	BOARD FEET
1" X 4"	192	64
1" X 6"	400	200
2" X 2"	73	25
2" X 3"	28	14
2" X 4"	367	265
2" X 6"	183	183
4" X 4"	100	134
NAILS	NO. REQD	POUNDS
6d (2")	300	1-3/4
10d (3")	620	9-3/4
12d (3-1/4")	58	1
16d (3-1/2")	96	2-1/4
WIRE, NO. 14 GAGE ----- 36' REQD ----- NIL		

LOAD AS SHOWN

ITEM	QUANTITY	WEIGHT (APPROX)
PALLET UNIT	48	103,104 LBS
DUNNAGE		1,745 LBS
TOTAL WEIGHT		104,849 LBS

ALTERNATED CONTAINERS UNIT (INCREASED HEIGHT)  
48-UNIT LOAD IN A 60'-8" LONG BY 9'-2" WIDE CONVENTIONAL BOX CAR

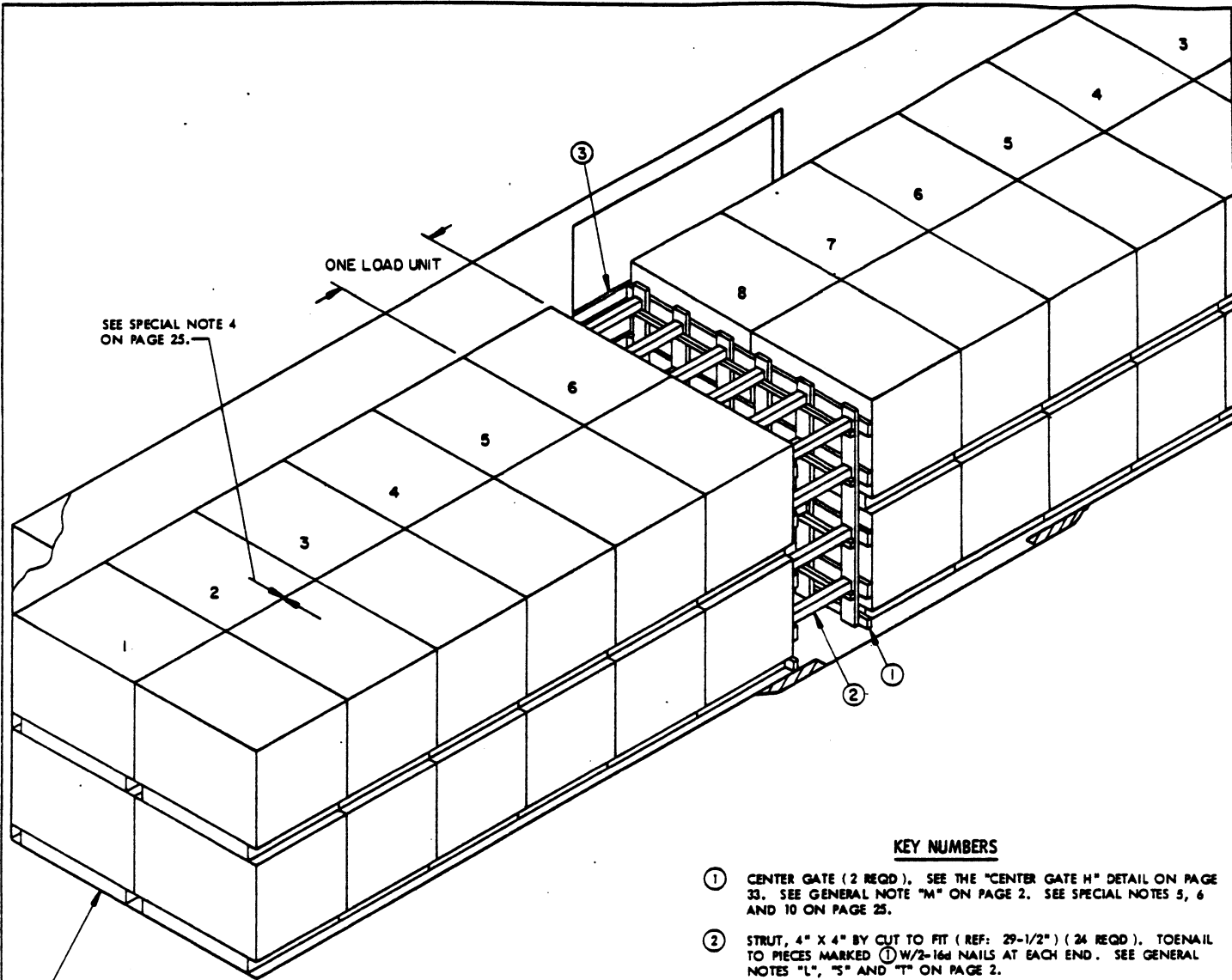

ISOMETRIC VIEW

KEY NUMBERS

- ① CENTER GATE (2 REQD). SEE THE "CENTER GATE H" DETAIL ON PAGE 33. SEE GENERAL NOTE "M" ON PAGE 2. SEE SPECIAL NOTES 5, 6 AND 10 ON PAGE 25.
- ② STRUT, 4" X 4" BY CUT TO FIT (REF: 29-1/2") (24 REQD). TOENAIL TO PIECES MARKED ① W/2-16d NAILS AT EACH END. SEE GENERAL NOTES "L", "5" AND "T" ON PAGE 2.
- ③ DOORWAY PROTECTION (2 REQD). SEE THE "DOORWAY PROTECTION C" DETAIL ON PAGE 32. NAIL TO THE DOOR POSTS W/12d NAILS. SEE SPECIAL NOTE 8 ON PAGE 25.

SEE GENERAL NOTE "G" ON PAGE 2.

SEE SPECIAL NOTE 4 ON PAGE 25.

ONE LOAD UNIT

ALTERNATED CONTAINERS UNIT (INCREASED HEIGHT)  
 56-UNIT LOAD IN A 50'-6" LONG BY 9'-4" WIDE CONVENTIONAL BOX CAR



**SPECIAL NOTES:**

1. A 50'-6" LONG BY 9'-4" WIDE WOOD-LINED CONVENTIONAL TYPE BOX CAR EQUIPPED WITH 8'-0" WIDE DOOR OPENINGS IS SHOWN. WIDER CARS OF OTHER LENGTHS AND CARS HAVING WIDER OR NARROWER DOOR OPENINGS CAN BE USED. SEE GENERAL NOTE "D" ON PAGE 2 AND SPECIAL NOTE 3 BELOW.
2. THE PALLETIZED UNIT SHOWN IN THE TYPICAL LOAD ON PAGE 24 IS THE ALTERNATED CONTAINER UNIT ( INCREASED HEIGHT ). A MAXIMUM OF FORTY-FOUR ( 44 ) OF THESE UNITS, FOR AN APPROXIMATE LADING WEIGHT OF 94,512 POUNDS CAN BE PLACED IN A 40'-6" LONG CAR WHEN USING THE DEPICTED PROCEDURES. IF A 60'-8" LONG BY 9'-4" OR WIDER CAR IS AVAILABLE, SIXTY-EIGHT ( 68 ) PALLET UNITS FOR AN APPROXIMATE LADING WEIGHT OF 146,064 POUNDS CAN BE LOADED. SEE SPECIAL NOTE 10 FOR CENTER GATE MODIFICATIONS WHICH MUST BE MADE IF 60' LONG CARS ARE TO BE USED.
3. THE DEPICTED LOADING PATTERN IS ADEQUATE FOR CARS HAVING DOOR OPENINGS 8' OR WIDER. IF THE CAR TO BE LOADED HAS DOOR OPENINGS LESS THAN 8'-0" WIDE AND NOT OF SUFFICIENT HEIGHT TO ALLOW PERSONNEL TO EXIT THE CAR OVER THE TOP OF THE LOAD WHEN NECESSARY, THE PALLETS SHOULD BE POSITIONED SO THERE ARE SEVEN ( 7 ) LOAD UNITS IN EACH END. NOTE THAT ALTHOUGH CARS HAVING DOOR OPENINGS AS NARROW AS 6'-0" WIDE CAN BE USED FOR FULL LOADS, LOADING IS PROGRESSIVELY MORE DIFFICULT AS THE WIDTH OF THE DOOR OPENING DECREASES.
4. ANTI-SWAY BRACING BETWEEN LATERALLY ADJACENT ROWS OF PALLET UNITS IS NOT REQUIRED REGARDLESS OF THE WIDTH OF THE CAR BEING LOADED.
5. CENTER GATE "H" MAY BE PARTIALLY FORMED FROM 1/2" OR THICKER PLYWOOD, IF DESIRED. PLYWOOD MAY BE USED IN LIEU OF THE 2" X 6" HORIZONTAL PIECES. SEE THE "PLYWOOD CENTER GATE ALTERNATIVE" DETAIL ON PAGE 123 FOR GUIDANCE.
6. FOR EASE OF HANDLING, SPLIT CENTER GATES, WHICH ARE NOT DEPENDENT UPON THE WIDTH OF THE CAR, MAY BE USED AS AN ALTERNATIVE TO THE CAR-WIDTH GATES. IN LIEU OF EACH "CENTER GATE H", SHOWN AS PIECE MARKED ① IN THE LOAD ON PAGE 24, INSTALL TWO ( 2 ) "CENTER GATES F" AS SHOWN ON PAGE 31. AFTER THE SPLIT GATES AND STRUTS HAVE BEEN INSTALLED, THE SPLIT GATES MUST BE TIED TOGETHER AS DEPICTED BY THE "TIE PIECE APPLICATION" DETAIL ON PAGE 123.
7. DOOR SPANNER TYPE GATE HOLD DOWN MAY BE USED IN LIEU OF THE DOUBLED 2" X 3" HOLD DOWNS ON CENTER GATES "H" PROVIDING THE CAR BEING LOADED HAS AVAILABLE SIDEWALLS. SEE THE DETAILS ON PAGE 125 FOR GUIDANCE.
8. DOORWAY PROTECTION IS REQUIRED FOR ALL PALLET UNIT STACKS WHICH ARE COMPLETELY WITHIN THE DOORWAY AREA OR WHICH EXTEND INTO THE DOORWAY AREA BY ONE-HALF OR MORE OF THE STACK LENGTH. THE WOODEN GATE TYPE OF DOORWAY PROTECTION, SHOWN AS PIECES MARKED ③ IN THE LOAD ON PAGE 24, IS APPLICABLE FOR BOXCARS EQUIPPED WITH CONVENTIONAL SLIDING DOORS AND AVAILABLE DOOR POSTS. REFER TO PAGES 126 THRU 128 FOR ALTERNATIVE DOORWAY PROTECTION FOR CARS EQUIPPED WITH CONVENTIONAL SLIDING DOORS. IF THE CAR BEING LOADED IS EQUIPPED WITH PLUG TYPE DOORS, NAILED FLOORLINE BLOCKING AND LOAD BUNDLING STRAPS MUST BE USED. SEE THE "ALTERNATIVE DOORWAY PROTECTION E" DETAIL ON PAGE 128 FOR GUIDANCE.
9. THE DEPICTED LOAD CAN BE REDUCED TO SUIT THE QUANTITY TO BE SHIPPED. A 2-TIER LOAD CAN BE REDUCED BY A MULTIPLE OF FOUR ( 4 ) PALLET UNITS OR A 1-TIER LOAD CAN BE REDUCED BY A MULTIPLE OF TWO ( 2 ) UNITS BY OMITTING ONE OR MORE LOAD UNITS FROM THE CENTER PORTION OF THE LOAD, OR THE ENTIRE TOP TIER CAN BE OMITTED. FOR OTHER METHODS OF REDUCING A LOAD, AND FOR TYPICAL LCL PROCEDURES, REFER TO PAGES 92 THRU 120 FOR GUIDANCE.
10. IF A FULL LOAD IS TO BE SHIPPED IN A 60' LONG CAR, NINE ( 9 ) STRUTS WILL BE REQUIRED PER ROW/TIER. TO ACCOMMODATE THESE ADDITIONAL STRUTS, A HORIZONTAL PIECE AND STRUT LEDGER MUST BE ADDED TO CENTER GATE "H" FOR EACH TIER AS SHOWN BY THE PHANTOMED LINES ON THE DETAIL ON PAGE 33.
11. IF PALLET UNITS WHICH DO NOT CONTAIN A FULL QUANTITY OF CONTAINERS ARE TO BE TRANSPORTED, REFER TO PAGES 118 AND 120 FOR SHIPPING GUIDANCE.
12. FOR SHIPMENT OF ONE OR MORE LEFTOVER CONTAINERS, SEE THE "PROCEDURES FOR SHIPMENT OF LEFTOVER CONTAINERS" ON PAGE 119 FOR GUIDANCE.

**BILL OF MATERIAL**

LUMBER	LINEAR FEET	BOARD FEET
1" X 6"	64	32
2" X 2"	68	23
2" X 3"	36	18
2" X 4"	19	13
2" X 6"	162	162
4" X 4"	59	79
NAILS	NO. REQD	POUNDS
6d ( 2" )	48	1/2
10d ( 3" )	300	4-3/4
12d ( 3-1/4" )	28	1/2
16d ( 3-1/2" )	96	2-1/4

**LOAD AS SHOWN**

ITEM	QUANTITY	WEIGHT ( APPROX )
PALLET UNIT	56	120,288 LBS
DUNNAGE		662 LBS
TOTAL WEIGHT		120,950 LBS

ALTERNATED CONTAINERS UNIT ( INCREASED HEIGHT )  
56-UNIT LOAD IN A 50'-6" LONG BY 9'-4" WIDE CONVENTIONAL BOX CAR

**CAR EQUIPMENT REQUIRED**

ADJUSTABLE WALL MEMBER (SEE "NOTE 1" BELOW)	32
CROSS MEMBER	20
DOORWAY MEMBER	8

NOTE 1: FOR CARS EQUIPPED WITH FIXED WALL MEMBERS LOCATED AT THE HEIGHTS SPECIFIED IN "SECTION G-G;" OMIT ALL REFERENCE TO "ADJUSTABLE WALL MEMBERS".

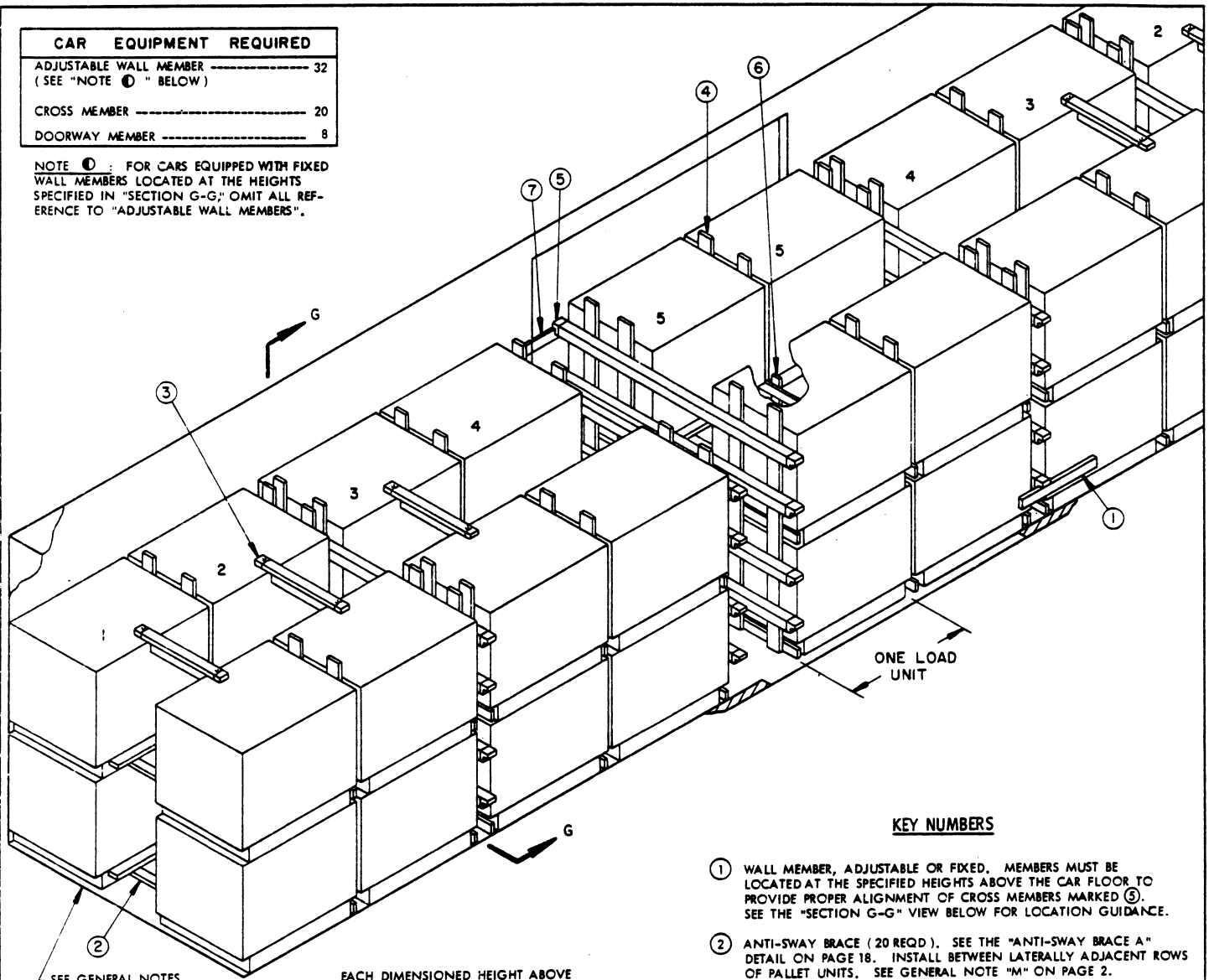

SEE GENERAL NOTES "D" AND "G" ON PAGE 2 AND SPECIAL NOTE 3 ON PAGE 27.

EACH DIMENSIONED HEIGHT ABOVE THE CAR FLOOR TO AN ADJUSTABLE OR FIXED WALL MEMBER MARKED 1 AND/OR A DOORWAY MEMBER MARKED 7 IS SPECIFIED TO LOCATE THE CENTER LINE OF A CROSS MEMBER.

**ISOMETRIC VIEW**

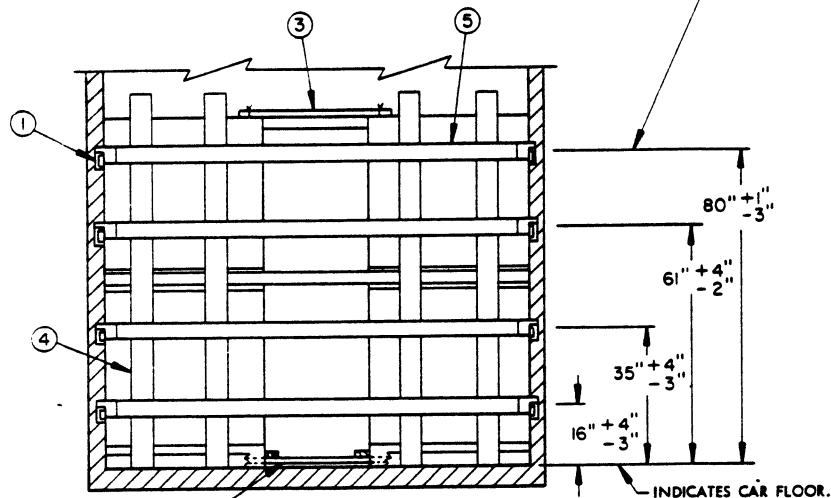

**SECTION G-G**

**KEY NUMBERS**

- 1 WALL MEMBER, ADJUSTABLE OR FIXED. MEMBERS MUST BE LOCATED AT THE SPECIFIED HEIGHTS ABOVE THE CAR FLOOR TO PROVIDE PROPER ALIGNMENT OF CROSS MEMBERS MARKED 5. SEE THE "SECTION G-G" VIEW BELOW FOR LOCATION GUIDANCE.
- 2 ANTI-SWAY BRACE (20 REQD). SEE THE "ANTI-SWAY BRACE A" DETAIL ON PAGE 18. INSTALL BETWEEN LATERALLY ADJACENT ROWS OF PALLET UNITS. SEE GENERAL NOTE "M" ON PAGE 2.
- 3 TOP-OF-LOAD ANTI-SWAY BRACE (6 REQD). SEE THE "TOP-OF-LOAD ANTI-SWAY BRACE A" DETAIL ON PAGE 19. WIRE TIE TO AN INNER UNITIZING STRAP WITH NO. 14 GAGE WIRE AS TYPICALLY SHOWN BY THE "TIE WIRE APPLICATION A" DETAIL ON PAGE 122. SEE SPECIAL NOTE 4 ON PAGE 27.
- 4 SEPARATOR GATE (13 REQD). SEE THE "SEPARATOR GATE D" DETAIL ON PAGE 31. AS APPLICABLE, POSITION WITH HORIZONTAL PIECES AGAINST THE ALREADY-LOADED UNITS. SEE SPECIAL NOTES 5 AND 7 ON PAGE 27.
- 5 CROSS MEMBER (20 REQD). SEE GENERAL NOTE "W" ON PAGE 3.
- 6 STOP PIECE, 1" X 4" X 52" (4 REQD). POSITION AGAINST PALLET UNITS IN THE DOORWAY AREA AND NAIL TO THE HORIZONTAL PIECES OF PIECE MARKED 4 W/3-6d NAILS AT EACH JOINT AND CLINCH. SEE SPECIAL NOTE 6 ON PAGE 27.
- 7 DOORWAY MEMBER (8 REQD). SEE THE "SECTION G-G" VIEW AT LEFT FOR LOCATION GUIDANCE.

**ALTERNATED CONTAINERS UNIT (INCREASED HEIGHT)**

**40-UNIT LOAD IN A 50'-6" LONG BY 9'-0" WIDE BOX CAR EQUIPPED WITH MECHANICAL BRACING DEVICES**

**SPECIAL NOTES:**

1. A 50'-6" LONG BY 9'-0" WIDE ( INSIDE CLEARANCE ) WOOD-LINED BOX CAR EQUIPPED WITH ADJUSTABLE AND/OR FIXED WALL MEMBERS, AND WITH 10'-0" WIDE DOOR OPENINGS IS SHOWN. CARS OF OTHER DIMENSIONS AND CARS HAVING WIDER OR NARROWER DOOR OPENINGS CAN BE USED. SEE GENERAL NOTE "D" ON PAGE 2.
2. THE PALLET UNIT SHOWN IN THE TYPICAL LOAD ON PAGE 26 IS THE ALTERNATED CONTAINERS UNIT ( INCREASED HEIGHT ). A MAXIMUM OF TWENTY-EIGHT ( 28 ) OF THESE UNITS, FOR AN APPROXIMATE LADING WEIGHT OF 60,144 POUNDS, CAN BE PLACED IN A 40'-6" LONG CAR.
3. IF A CAR HAS BOWED END WALLS WHICH ARE BOWED OUTWARD TWO INCHES ( 2" ) OR MORE EITHER FROM SIDE-TO-SIDE OR FROM FLOOR-TO-ROOF, CROSS MEMBERS CAN BE INSTALLED NEAR THE END WALL OF THE CAR TO PROVIDE A "SQUARED END" RATHER THAN INSTALLING DUNNAGE AS SPECIFIED IN GENERAL NOTE "G" ON PAGE 2. THESE CROSS MEMBERS SHOULD BE INSTALLED AT THE SAME HEIGHTS AS THE CROSS MEMBERS USED THROUGHOUT THE LOAD AS BLOCKING MEMBERS. A SEPARATOR GATE, SHOWN AS PIECE MARKED ( 4 ), MUST BE POSITIONED AGAINST THESE CROSS MEMBERS PRIOR TO LOADING.
4. TOP-OF-LOAD ANTI-SWAY BRACES, SHOWN AS PIECES MARKED ( 3 ) IN THE LOAD ON PAGE 26, MUST BE INSTALLED IN EACH END OF THE CAR AND WIRE TIED TO A UNITIZING STRAP WITH NO. 14 GAGE WIRE AS TYPICALLY SHOWN BY THE "TIE WIRE APPLICATION A" DETAIL ON PAGE 122. THREE ( 3 ) BRACES ARE REQUIRED IN EACH END OF A LOAD REGARDLESS OF THE CAR LENGTH.
5. TO FACILITATE POSITIONING OF THE PALLET UNITS AS LOADING PROGRESSES POSITION PALLET UNIT STACKS AGAINST THE END WALL, THEN POSITION A SEPARATOR GATE, SHOWN AS PIECE MARKED ( 4 ), SO THE 1" X 4" TIE PIECES ARE LOCATED UNDER THE "OVERHANG" OF THE PALLET UNITS. REPEAT THIS PROCEDURE FOR THE REMAINING STACKS.
6. SEPARATOR GATES IN THE DOORWAY MUST BE PREVENTED FROM SHIFTING INTO A DOOR OPENING BY THE APPLICATION OF THE STOP PIECES, PIECES MARKED ( 4 ). IN CARS EQUIPPED WITH STAGGERED DOORS, STOP PIECES MAY BE REQUIRED ON UP TO FOUR SEPARATOR GATES.
7. SEPARATOR GATES MAY BE FORMED FROM 3/8" OR THICKER PLYWOOD IN LIEU OF DIMENSIONAL LUMBER, IF DESIRED. SEE THE "ALTERNATIVE SEPARATOR GATE" DETAIL ON PAGE 122 FOR CONSTRUCTION GUIDANCE.
8. THE DEPICTED LOAD CAN BE REDUCED TO SUIT THE QUANTITY TO BE SHIPPED. A LOAD MAY BE REDUCED BY MULTIPLES OF TWO ( 2 ) PALLET UNITS BY OMITTING LATERALLY ADJACENT UNITS FROM THE TOP LAYER OF ONE OR MORE LOAD UNITS, OR BY MULTIPLES OF FOUR ( 4 ) PALLET UNITS BY OMITTING ONE OR MORE ENTIRE LOAD UNITS. TO REDUCE A LOAD BY ONE ( 1 ) PALLET UNIT, REFER TO THE LCL PROCEDURES ON PAGES 90 AND 91 FOR GUIDANCE.
9. FOR SHIPMENT OF ONE OR MORE LEFTOVER CONTAINERS, SEE THE "PROCEDURES FOR SHIPMENT OF LEFTOVER CONTAINERS" ON PAGE 119 FOR GUIDANCE.

**BILL OF MATERIAL**

LUMBER	LINEAR FEET	BOARD FEET
1" X 4"	251	84
1" X 6"	416	208
2" X 4"	293	196
NAILS	NO. REQD	POUNDS
6d ( 2" )	336	2
10d ( 3" )	240	3-3/4
12d ( 3-1/4" )	30	1/2
WIRE, NO. 14 GAGE -----	36' REQD -----	NIL

**LOAD AS SHOWN**

ITEM	QUANTITY	WEIGHT ( APPROX )
PALLET UNIT -----	40 -----	85,920 LBS
DUNNAGE-----	-----	983 LBS
TOTAL WEIGHT -----	-----	86,903 LBS

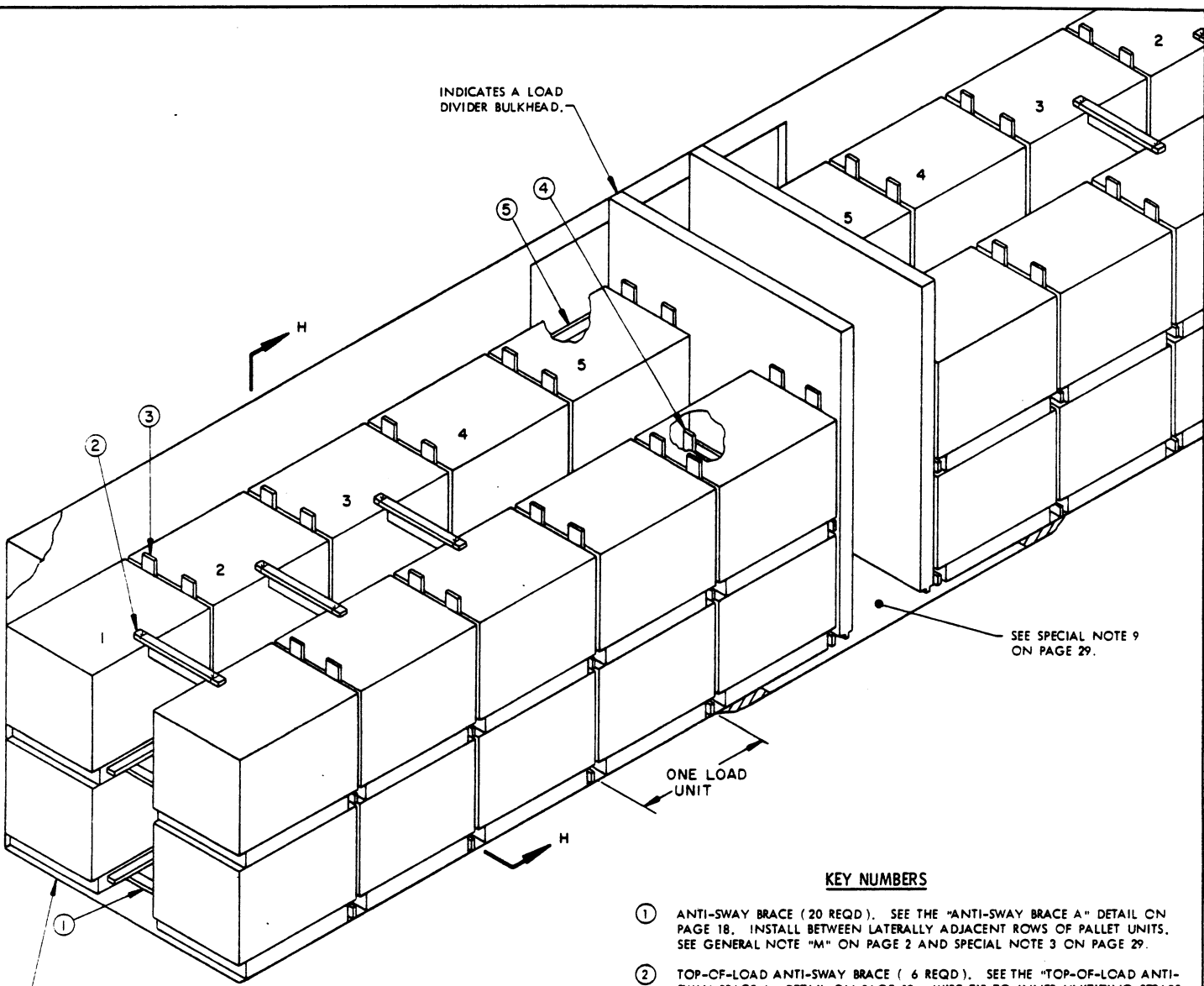

INDICATES A LOAD  
DIVIDER BULKHEAD.

SEE SPECIAL NOTE 9  
ON PAGE 29.

ONE LOAD  
UNIT

SEE GENERAL NOTES "D"  
AND "G" ON PAGE 2

**ISOMETRIC VIEW**

**KEY NUMBERS**

- ① ANTI-SWAY BRACE (20 REQD). SEE THE "ANTI-SWAY BRACE A" DETAIL ON PAGE 18. INSTALL BETWEEN LATERALLY ADJACENT ROWS OF PALLET UNITS. SEE GENERAL NOTE "M" ON PAGE 2 AND SPECIAL NOTE 3 ON PAGE 29.
- ② TOP-OF-LOAD ANTI-SWAY BRACE ( 6 REQD). SEE THE "TOP-OF-LOAD ANTI-SWAY BRACE A" DETAIL ON PAGE 19. WIRE TIE TO INNER UNITIZING STRAPS WITH NO. 14 GAGE WIRE AS TYPICALLY SHOWN BY THE "TIE WIRE APPLICATION A" DETAIL ON PAGE 122. SEE SPECIAL NOTE 4 ON PAGE 29.
- ③ SEPARATOR GATE (10 REQD). SEE THE "SEPARATOR GATE D" DETAIL ON PAGE 31. POSITION WITH THE HORIZONTAL PIECES AGAINST THE ALREADY-LOADED UNITS. SEE SPECIAL NOTES 5 AND 7 ON PAGE 29.
- ④ STOP PIECE, 1" X 4" X 52" (4 REQD). POSITION AGAINST PALLET UNITS IN THE DOORWAY AREA AND NAIL TO THE HORIZONTAL PIECES OF PIECE MARKED ③ W/3-6d NAILS AT EACH END AND CLINCH. SEE SPECIAL NOTE 6 ON PAGE 29.
- ⑤ DOORWAY PROTECTION (2 REQD). SEE THE "DOORWAY PROTECTION C" DETAIL ON PAGE 32. NAIL TO THE DOOR POSTS W/12d NAILS. SEE SPECIAL NOTE 8 ON PAGE 29.

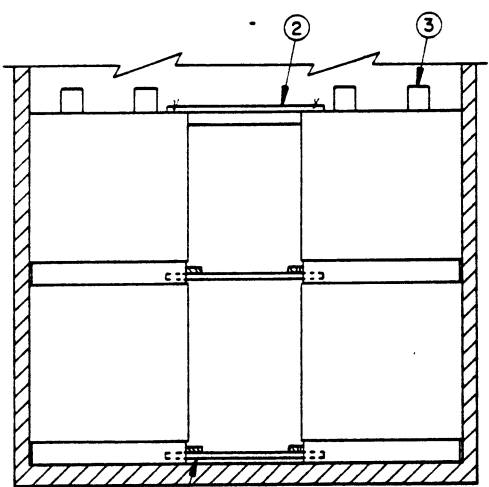

**SECTION H-H**

ALTERNATED CONTAINERS UNIT ( INCREASED HEIGHT )  
40-UNIT LOAD IN A 50'-6" LONG BY 9'-2" WIDE BOX CAR EQUIPPED WITH LOAD DIVIDERS

( SPECIAL NOTES CONTINUED )

- 10. THE DEPICTED LOAD CAN BE REDUCED TO SUIT THE QUANTITY TO BE SHIPPED. A 2-TIER LOAD CAN BE REDUCED BY A MULTIPLE OF FOUR ( 4 ) PALLET UNITS OR A 1-TIER LOAD CAN BE REDUCED BY A MULTIPLE OF TWO ( 2 ) UNITS BY OMITTING ONE OR MORE LOAD UNITS FROM THE CENTER PORTION OF THE LOAD. OR, THE ENTIRE TOP TIER CAN BE OMITTED. FOR OTHER METHODS OF REDUCING A LOAD, AND FOR TYPICAL LCL PROCEDURES, REFER TO PAGES 94 THRU 105 AND GENERAL NOTE "FF" ON PAGE 3 FOR GUIDANCE.
- 11 IF PALLET UNITS WHICH DO NOT CONTAIN A FULL QUANTITY OF CONTAINERS ARE TO BE TRANSPORTED, REFER TO PAGE 117 AND/OR PAGES 118 AND 120 FOR SHIPPING GUIDANCE.
- 12 FOR SHIPMENT OF ONE OR MORE LEFTOVER CONTAINERS, SEE THE "PROCEDURES FOR SHIPMENT OF LEFTOVER CONTAINERS" ON PAGE 119 FOR GUIDANCE.

SPECIAL NOTES:

- 1. A 50'-6" LONG BY 9'-2" WIDE WOOD-LINED, CUSHIONED BOX CAR EQUIPPED WITH LOAD DIVIDER BULKHEADS AND WITH 10'-0" WIDE DOOR OPENINGS IS SHOWN. CARS OF OTHER DIMENSIONS AND CARS HAVING NARROWER OR WIDER DOOR OPENINGS CAN BE USED. SEE GENERAL NOTES "AA" THRU "EE" ON PAGE 3.
- 2. THE PALLET UNIT SHOWN IN THE TYPICAL LOAD ON PAGE 28 IS THE ALTERNATED CONTAINERS UNIT ( INCREASED HEIGHT ). A MAXIMUM OF FORTY-EIGHT ( 48 ) OF THESE UNITS, FOR AN APPROXIMATE LADING WEIGHT OF 103,104 POUNDS, CAN BE PLACED IN A 60'-8" LONG CAR, OR A MAXIMUM OF THIRTY-TWO ( 32 ) UNITS CAN BE LOADED IN A 40'-6" CAR FOR AN APPROXIMATE LADING WEIGHT OF 68,736 POUNDS, WHEN USING THE DEPICTED PROCEDURES. IF CARS 9'-4" OR WIDER ARE AVAILABLE, THE CROSSWISE LOADING PATTERN SHOWN ON PAGE 24 MAY BE EMPLOYED. THEN, SIXTY-FOUR ( 64 ) PALLET UNITS FOR AN APPROXIMATE LADING WEIGHT OF 137,472 POUNDS CAN BE PLACED IN A 60'-8" LONG CAR, FIFTY-TWO ( 52 ) UNITS CAN BE LOADED IN A 50'-6" LONG CAR FOR AN APPROXIMATE LADING WEIGHT OF 111,696 POUNDS, AND FORTY ( 40 ) UNITS CAN BE LOADED IN A 40'-6" LONG CAR FOR AN APPROXIMATE LADING WEIGHT OF 85,920 POUNDS.
- 3. IF THE "ALTERNATIVE DOORWAY PROTECTION F" PROCEDURES AS SHOWN ON PAGE 128 ARE USED IN LIEU OF THE WOODEN DOOR GATE TYPE PROTECTION, PIECE MARKED ⑤, NAILED FLOORLINE BLOCKING MUST BE USED IN LIEU OF THE LOWER ANTI-SWAY BRACES IN THE DOORWAY AREA. NAILED BLOCKING IS REQUIRED FOR ALL PALLET STACKS WHICH ARE COMPLETELY WITHIN THE DOORWAY AREA OR WHICH EXTEND INTO THE DOORWAY AREA BY ONE-HALF OR MORE OF THE STACK WIDTH ON EITHER SIDE OF THE CAR.
- 4. TOP-OF-LOAD ANTI-SWAY BRACES, SHOWN AS PIECES MARKED ② IN THE LOAD ON PAGE 28, MUST BE INSTALLED IN EACH END OF THE CAR AND WIRE TIED TO UNITIZING STRAPS WITH NO. 14 GAGE WIRE AS TYPICALLY SHOWN BY THE "TIE WIRE APPLICATION A" DETAIL ON PAGE 122. THREE ( 3 ) BRACES ARE REQUIRED IN EACH END OF A LOAD REGARDLESS OF THE CAR LENGTH.
- 5. TO FACILITATE POSITIONING OF THE PALLET UNITS AS LOADING PROGRESSES, POSITION PALLET UNIT STACKS AGAINST THE END WALL, THEN POSITION A SEPARATOR GATE SHOWN AS PIECE MARKED ③, SO THE 1" X 4" TIE PIECES ARE LOCATED UNDER THE "OVERHANG" OF THE PALLET UNITS. REPEAT THIS PROCEDURE FOR THE REMAINING STACKS.
- 6. SEPARATOR GATES IN THE DOORWAY MUST BE PREVENTED FROM SHIFTING INTO A DOOR OPENING BY THE APPLICATION OF THE STOP PIECES, PIECES MARKED ④. IN CARS EQUIPPED WITH STAGGERED DOORS, STOP PIECES MAY BE REQUIRED ON UP TO FOUR SEPARATOR GATES.
- 7. SEPARATOR GATES MAY BE FORMED FROM 3/8" OR THICKER PLYWOOD IN LIEU OF DIMENSIONAL LUMBER, IF DESIRED. SEE THE "ALTERNATIVE SEPARATOR GATE " DETAIL ON PAGE 122 FOR CONSTRUCTION GUIDANCE.
- 8. DOORWAY PROTECTION IS REQUIRED FOR ALL PALLET UNIT STACKS WHICH ARE COMPLETELY WITHIN THE DOORWAY AREA OR WHICH EXTEND INTO THE DOORWAY AREA BY ONE-HALF OR MORE OF THE STACK WIDTH. THE WOODEN GATE TYPE OF DOORWAY PROTECTION, SHOWN AS PIECES MARKED ⑥ IN THE LOAD ON PAGE 28, IS APPLICABLE FOR BOX CARS EQUIPPED WITH CONVENTIONAL SLIDING DOORS AND NAILABLE DOOR POSTS. REFER TO PAGES 126 THRU 128 FOR ALTERNATIVE DOORWAY PROTECTION FOR CARS EQUIPPED WITH CONVENTIONAL SLIDING DOORS. IF THE CAR BEING LOADED IS EQUIPPED WITH PLUG TYPE DOORS, NAILED FLOORLINE BLOCKING AND LOAD BUNDLING STRAPS MUST BE USED. SEE THE "ALTERNATIVE DOORWAY PROTECTION F" DETAIL ON PAGE 128 FOR GUIDANCE IF THE PALLET UNITS ARE POSITIONED AS SHOWN ON PAGE 28. SEE THE "ALTERNATIVE DOORWAY PROTECTION E" DETAIL ON THAT PAGE IF THE PALLET UNITS ARE POSITIONED CROSSWISE.
- 9. A STRUT ASSEMBLY, SHOWN AS PIECE MARKED ⑦ IN THE LOAD ON PAGE 42, IS REQUIRED BETWEEN THE LOAD DIVIDER BULKHEADS WHEN THE LOAD IN EITHER END OF THE CAR IS 50,000 POUNDS OR MORE. FOR THE DEPICTED PALLET UNIT, A STRUT ASSEMBLY WILL BE REQUIRED IF THE LOAD IN ONE END OF THE CAR CONSISTS OF MORE THAN FIVE ( 5 ) LOAD UNITS, WHICH WOULD BE THE CASE IF AN OFFSET LOADING PATTERN IS EMPLOYED. THE STRUT ASSEMBLY WILL ALWAYS BE REQUIRED FOR FULL LOADS IN 60' OR LONGER CARS.

( CONTINUED AT LEFT )

BILL OF MATERIAL		
LUMBER	LINEAR FEET	BOARD FEET
1" X 4"	200	67
1" X 6"	400	200
2" X 3"	28	14
2" X 4"	302	202
NAILS	NO. REQD	POUNDS
6d ( 2" )	312	2
10d ( 3" )	240	3-3/4
12d ( 3-1/4" )	58	1
WIRE, NO. 14 GAGE -----36' REQD-----NIL		

LOAD AS SHOWN

ITEM	QUANTITY	WEIGHT ( APPROX )
PALLET UNIT -----	40 -----	85,920 LBS
DUNNAG E-----	-----	973 LBS
TOTAL WEIGHT ---		86,893 LBS

ALTERNATED CONTAINERS UNIT ( INCREASED HEIGHT )  
40-UNIT LOAD IN A 50'-6" LONG BY 9'-2" WIDE BOX CAR EQUIPPED WITH LOAD DIVIDERS

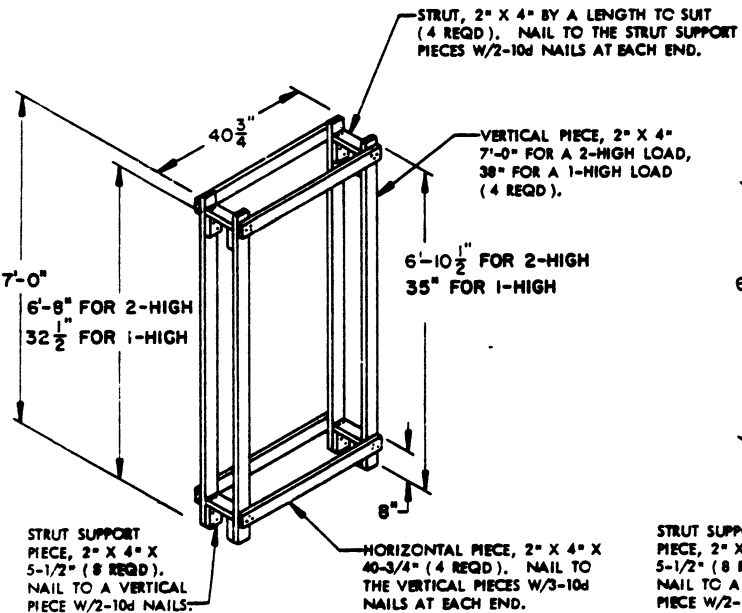

**CRIB FILL C**

CRIB FILL ASSEMBLIES "C" AND "D" SHOULD BE PRE-FABRICATED. CONSTRUCT TO BE 1/2" TO 3/4" LESS IN WIDTH THAN THE DISTANCE BETWEEN LATERALLY ADJACENT ROWS OF BALLET UNITS.

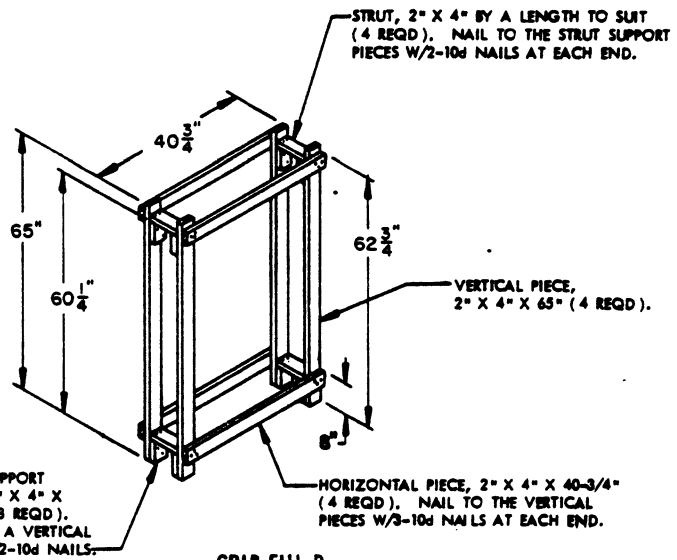

**CRIB FILL D**

CRIB FILL "D" IS NOT REQUIRED FOR A 1-HIGH LOAD; CRIB FILL "C" WILL BE USED THROUGHOUT THE LENGTH OF THE LOAD.

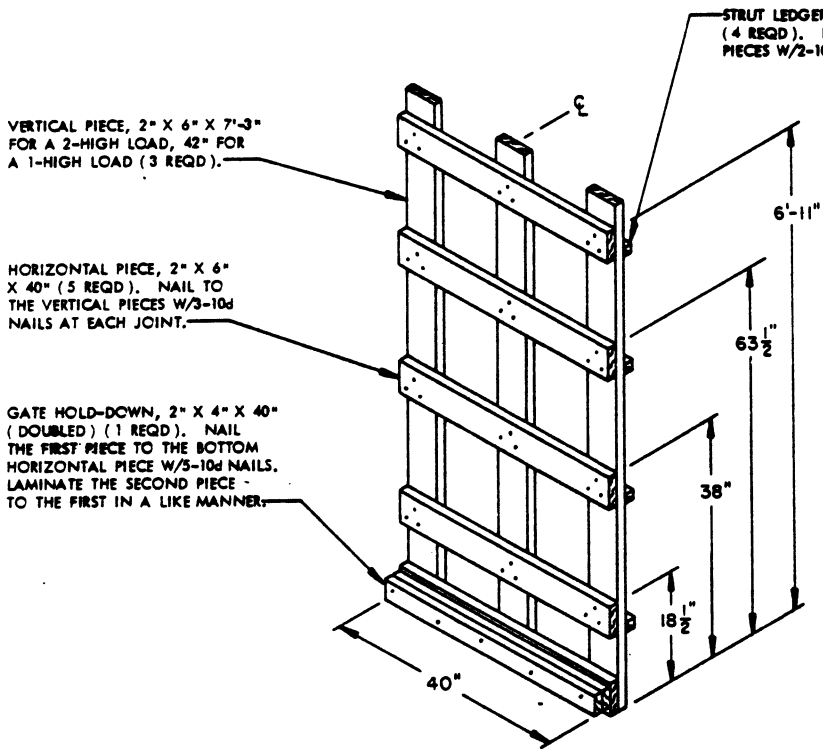

**CENTER GATE E**

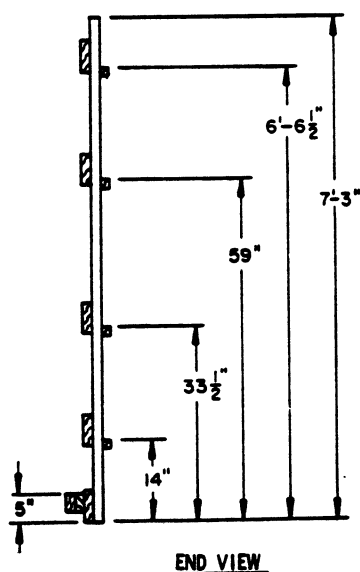

**END VIEW**

**DETAILS FOR ALTERNATED CONTAINERS UNIT ( INCREASED HEIGHT )**

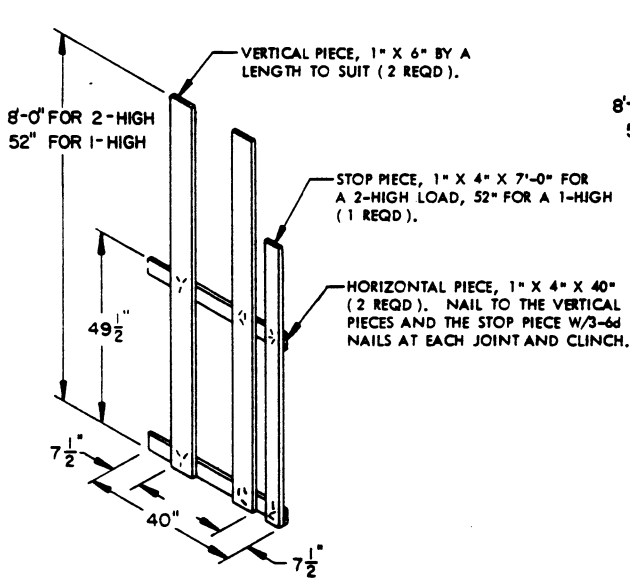

**SEPARATOR GATE C**

RIGHT HAND AND LEFT HAND GATES ARE REQUIRED. A RIGHT HAND GATE IS SHOWN.

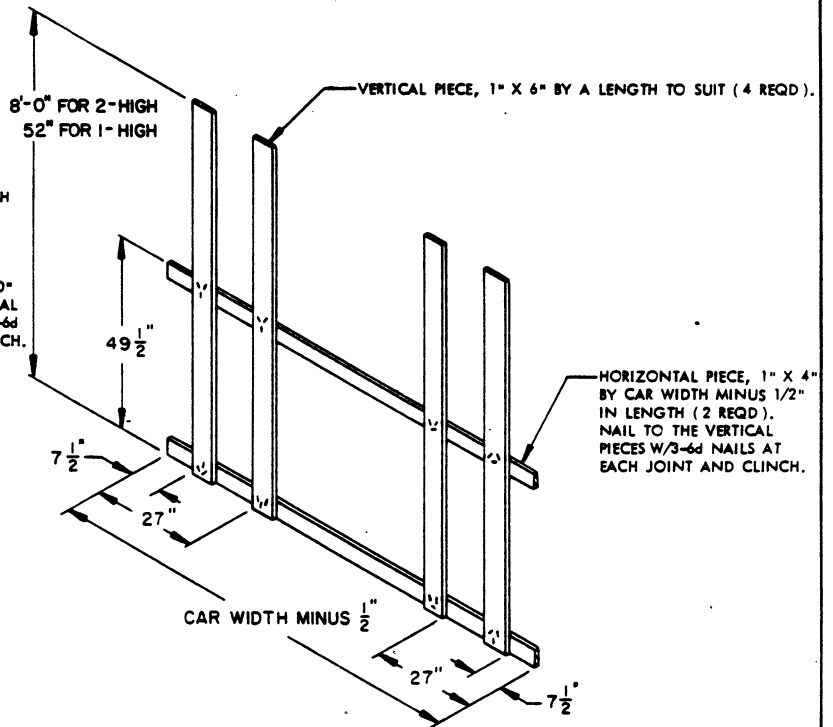

**SEPARATOR GATE D**

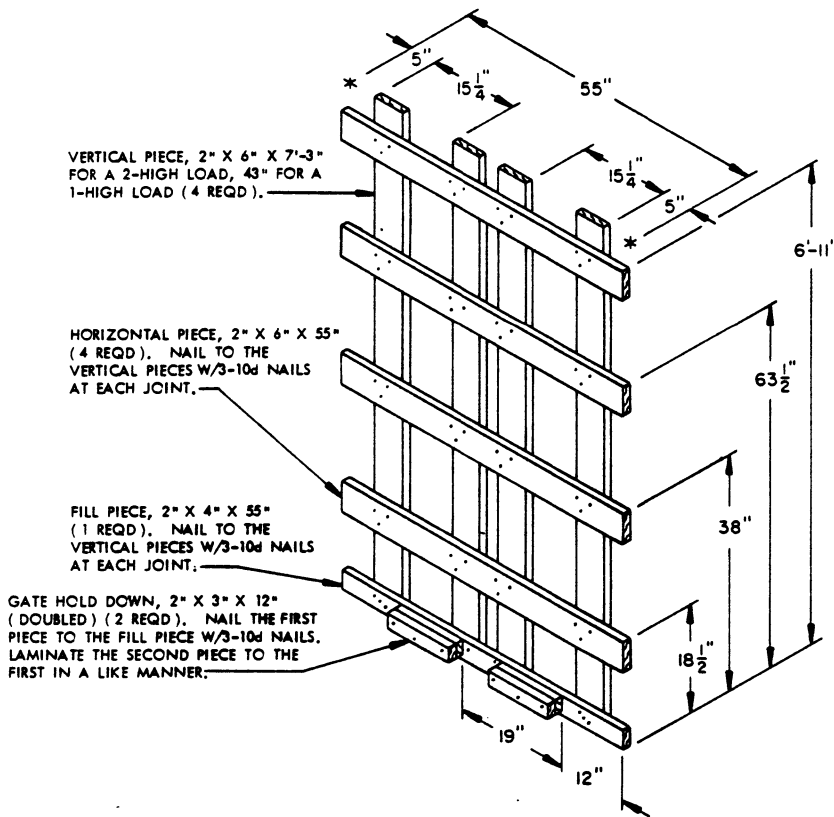

**CENTER GATE F**

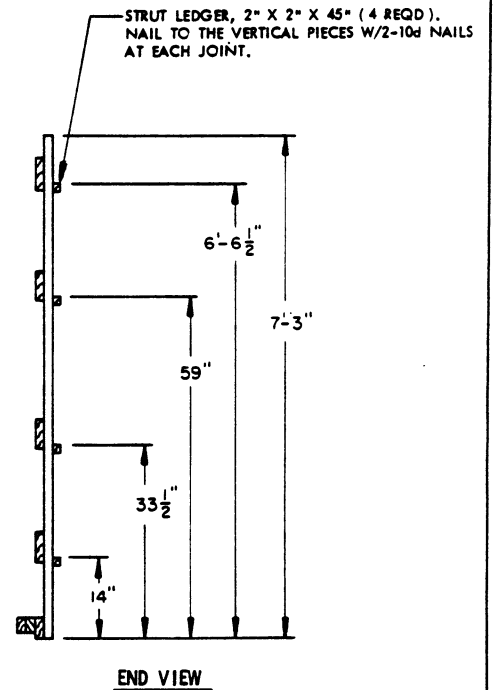

**END VIEW**

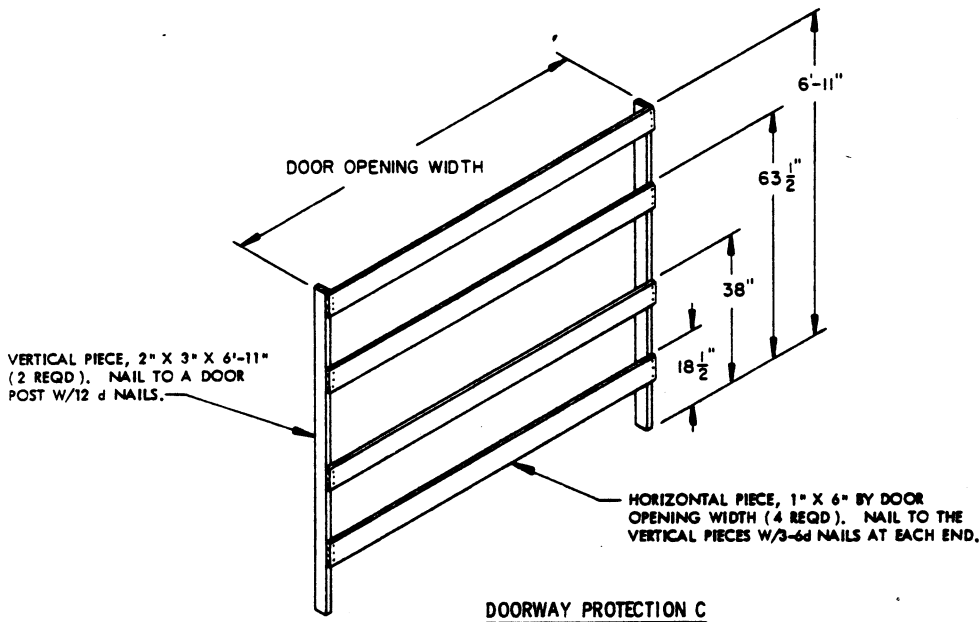

**DOORWAY PROTECTION C**

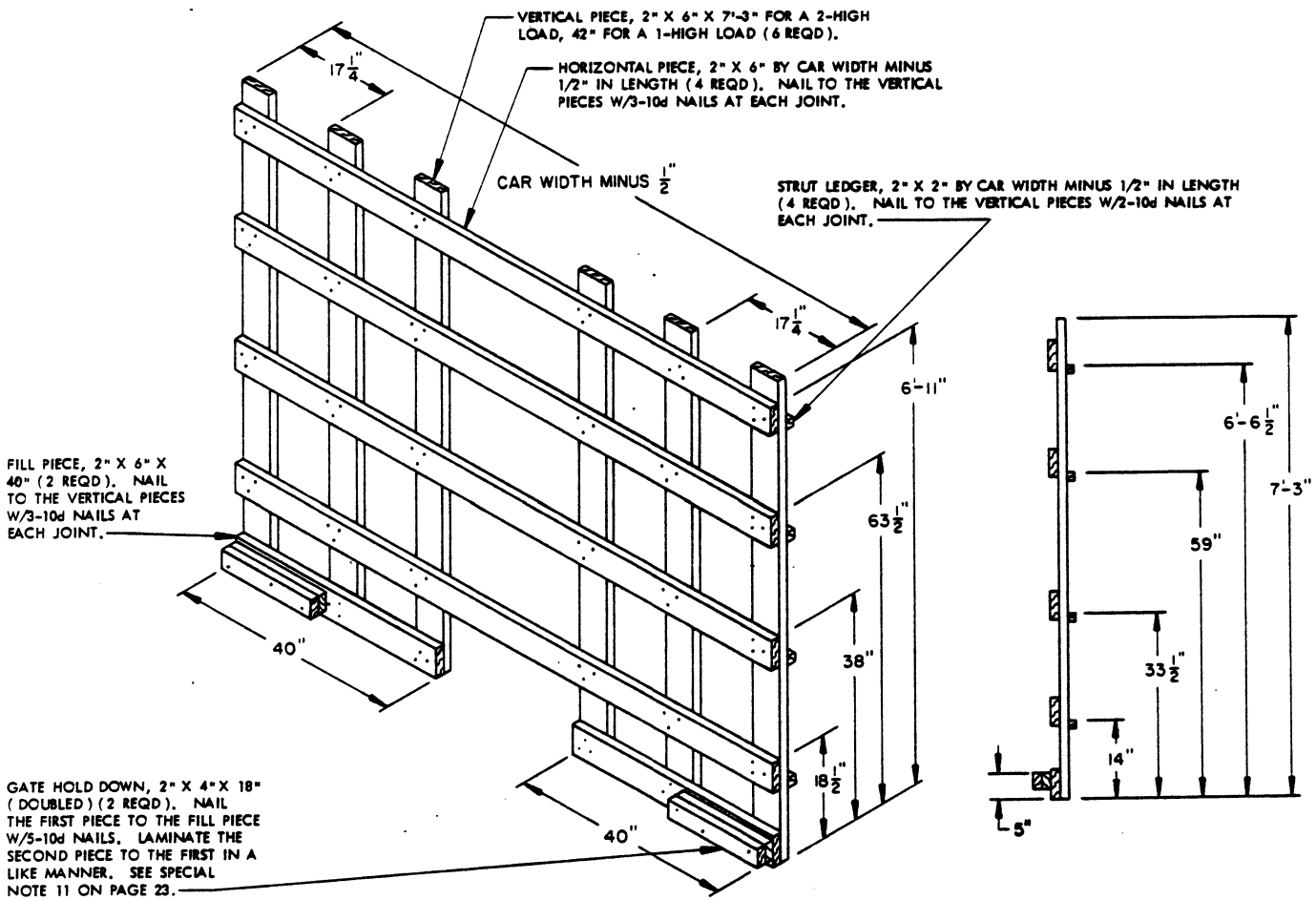

**CENTER GATE G**



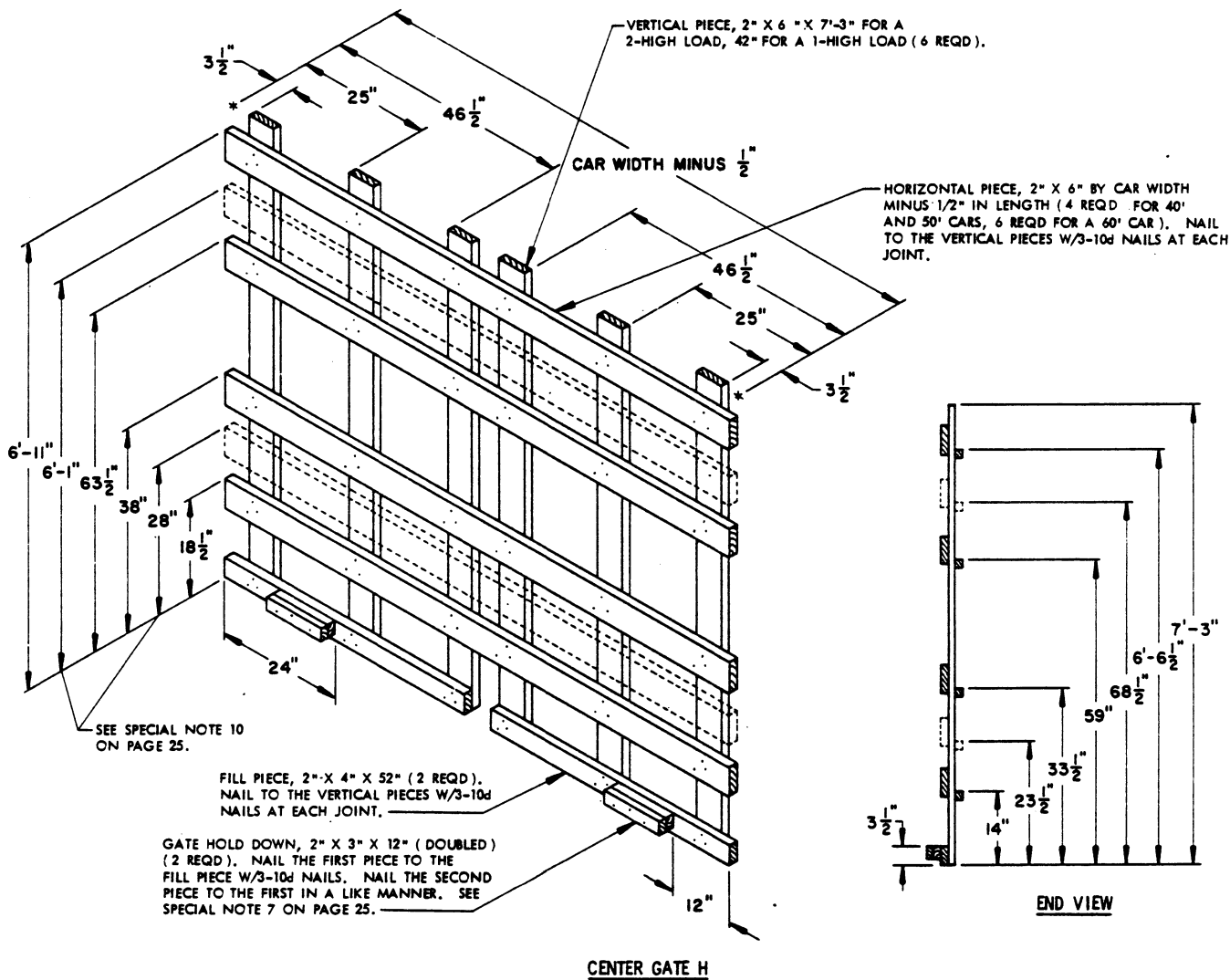

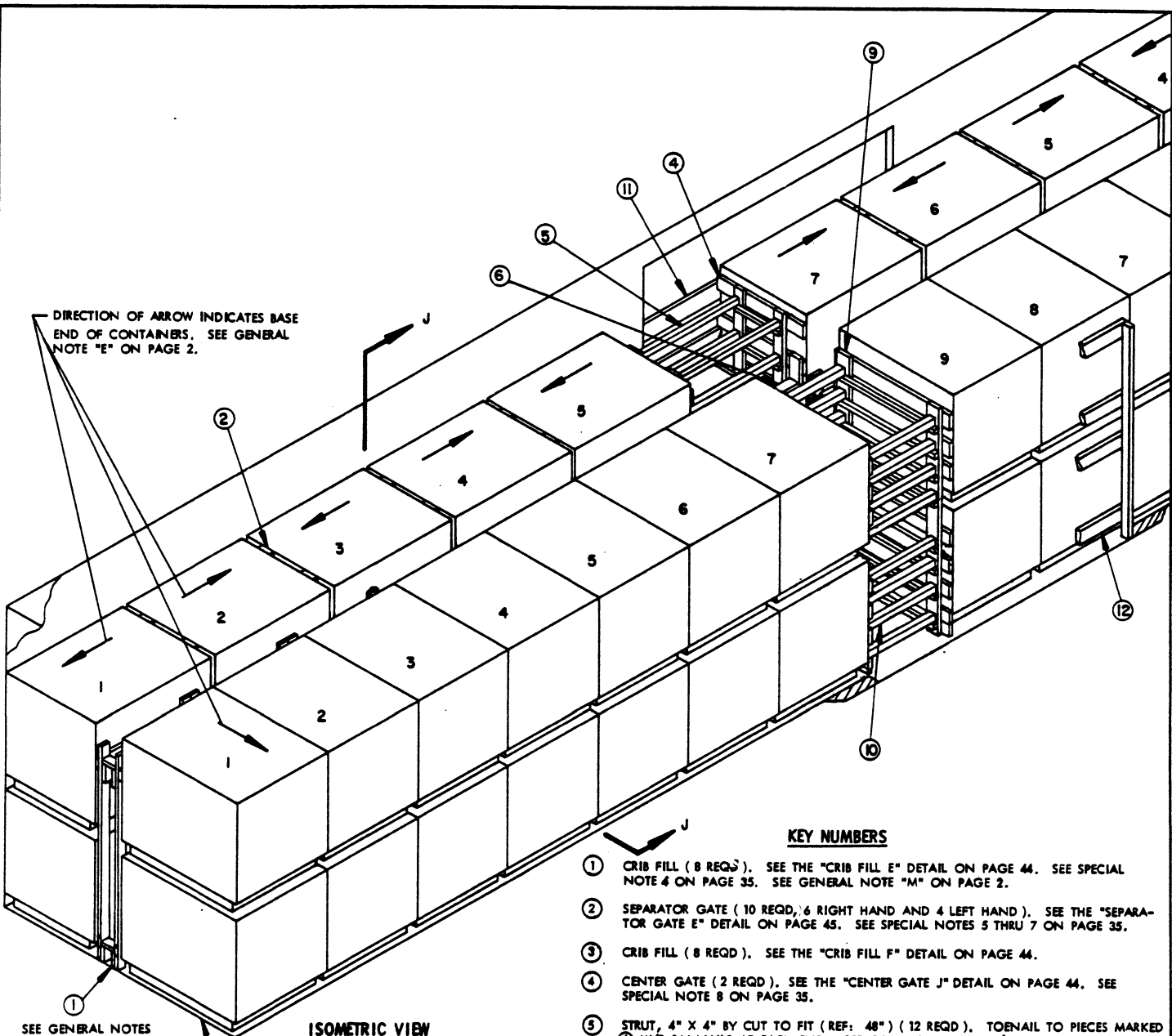

DIRECTION OF ARROW INDICATES BASE END OF CONTAINERS. SEE GENERAL NOTE "E" ON PAGE 2.

**ISOMETRIC VIEW**

SEE GENERAL NOTES "D" AND "G" ON PAGE 2.

**KEY NUMBERS**

- ① CRIB FILL (8 REQD). SEE THE "CRIB FILL E" DETAIL ON PAGE 44. SEE SPECIAL NOTE 4 ON PAGE 35. SEE GENERAL NOTE "M" ON PAGE 2.
- ② SEPARATOR GATE (10 REQD, 6 RIGHT HAND AND 4 LEFT HAND). SEE THE "SEPARATOR GATE E" DETAIL ON PAGE 45. SEE SPECIAL NOTES 5 THRU 7 ON PAGE 35.
- ③ CRIB FILL (8 REQD). SEE THE "CRIB FILL F" DETAIL ON PAGE 44.
- ④ CENTER GATE (2 REQD). SEE THE "CENTER GATE J" DETAIL ON PAGE 44. SEE SPECIAL NOTE 8 ON PAGE 35.
- ⑤ STRUT, 4" X 4" BY CUT TO FIT (REF: 48") (12 REQD). TOENAIL TO PIECES MARKED ④ W/2-16d NAILS AT EACH END. SEE GENERAL NOTES "L", "S", AND "T" ON PAGE 2.
- ⑥ STRUT, 2" X 4" BY CUT TO FIT (REF: 48") (2 REQD). TOENAIL TO THE STOP PIECES OF PIECES MARKED ④ W/2-12d NAILS AT EACH END. SEE THE "PARTIAL PLAN VIEW" ON PAGE 35.
- ⑦ SIDE BLOCKING FOR CENTER GATE "J", 2" X 4" X 18" (DOUBLED) (1 REQD). NAIL THE FIRST PIECE TO THE CAR FLOOR W/4-16d NAILS. NAIL THE SECOND PIECE TO THE FIRST IN A LIKE MANNER. SEE THE "PARTIAL PLAN VIEW" ON PAGE 35.
- ⑧ CRIB FILL RETAINER, 2" X 4" BY A LENGTH TO SUIT (REF: 54") (2 REQD). POSITION TO SPAN THE STRUTS OF LONGITUDINALLY ADJACENT CRIB FILL "F" ASSEMBLIES AND NAIL TO EACH STRUT W/3-10d NAILS. SEE THE "PARTIAL PLAN VIEW" ON PAGE 35.
- ⑨ CENTER GATE (2 REQD). SEE THE "CENTER GATE K" DETAIL ON PAGE 45.
- ⑩ STRUT, 4" X 4" BY CUT TO FIT (REF: 34") (16 REQD). TOENAIL TO PIECES MARKED ⑨ W/2-16d NAILS AT EACH END.
- ⑪ DOORWAY PROTECTION (1 REQD). SEE THE "DOORWAY PROTECTION D" DETAIL ON PAGE 46. NAIL TO THE DOOR POSTS W/12d NAILS. SEE SPECIAL NOTE 9 ON PAGE 35.
- ⑫ DOORWAY PROTECTION (1 REQD). SEE THE "DOORWAY PROTECTION E" DETAIL ON PAGE 47. NAIL TO THE DOOR POSTS W/12d NAILS.

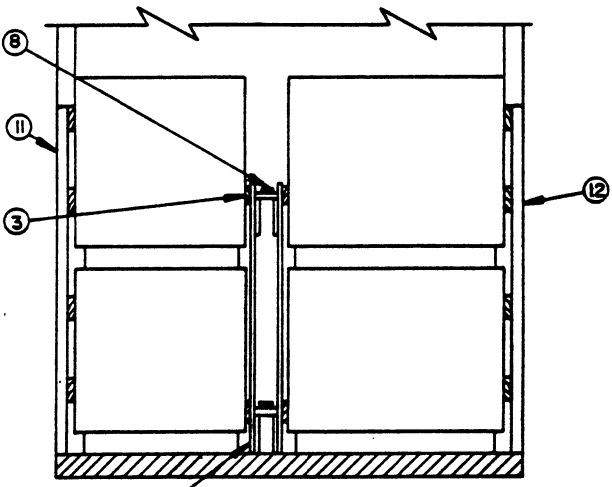

**SECTION J-J**

**FLAT DUNNAGE METHOD UNIT (BASIC HEIGHT)  
56-UNIT LOAD IN A 60'-8" LONG BY 9'-2" WIDE CONVENTIONAL BOX CAR**

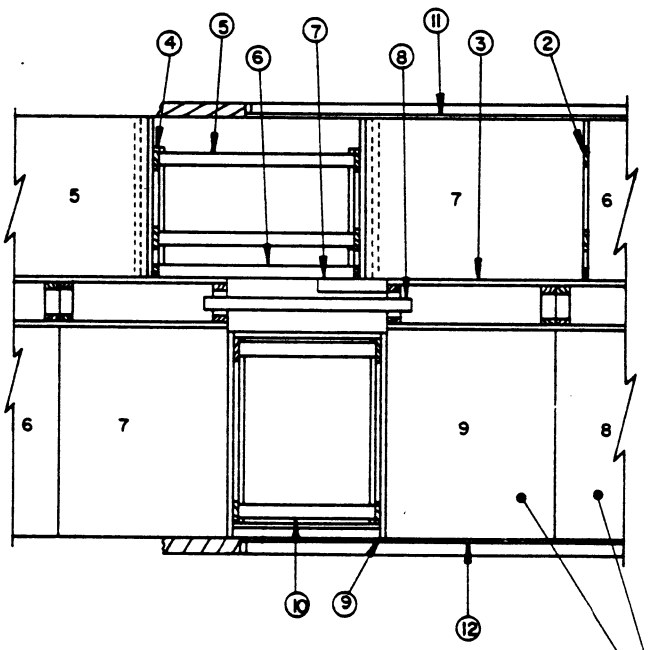

**PARTIAL PLAN VIEW**

IF THE CAR BEING LOADED IS EQUIPPED WITH PLUG TYPE DOORS, SEE SPECIAL NOTE 9 AT RIGHT.

**(SPECIAL NOTES CONTINUED)**

11. IF PALLETIZED UNITS WHICH DO NOT CONTAIN A FULL QUANTITY OF CONTAINERS ARE TO BE TRANSPORTED, REFER TO PAGE 117 FOR SHIPPING GUIDANCE FOR LENGTHWISE UNITS AND PAGES 118 AND 120 FOR CROSSWISE UNITS.
12. FOR SHIPMENT OF ONE OR MORE LEFTOVER CONTAINERS, SEE THE "PROCEDURES FOR SHIPMENT OF LEFTOVER CONTAINERS" ON PAGE 119 FOR GUIDANCE.

BILL OF MATERIAL		
LUMBER	LINEAR FEET	BOARD FEET
1" X 4"	147	49
1" X 6"	245	123
2" X 2"	95	32
2" X 3"	31	16
2" X 4"	816	344
4" X 4"	96	128
NAILS	NO. REQD	POUNDS
6d (2")	228	1-1/2
10d (3")	1,256	19-1/2
12d (3-1/4")	40	3/4
16d (3-1/2")	120	2-3/4
WIRE, NO. 14 GAGE ----- 3' REQD ----- NIL		

**SPECIAL NOTES:**

1. A 60'-8" LONG BY 9'-2" WIDE WOOD-LINED CONVENTIONAL TYPE BOX CAR EQUIPPED WITH 10'-0" WIDE DOOR OPENINGS IS SHOWN. CARS OF OTHER DIMENSIONS AND CARS HAVING WIDER OR NARROWER DOOR OPENINGS CAN BE USED. SEE SPECIAL NOTE 3 BELOW AND GENERAL NOTE "D" ON PAGE 2.
2. THE PALLET UNIT SHOWN IN THE TYPICAL LOAD ON PAGE 34 IS THE FLAT DUNNAGE METHOD UNIT (BASIC HEIGHT). A MAXIMUM OF FORTY-SIX (46) OF THESE UNITS, FOR AN APPROXIMATE LADING WEIGHT OF 97,842 POUNDS, CAN BE PLACED IN A 50'-6" LONG CAR WHEN USING THE DEPICTED PROCEDURES; THIRTY-SIX (36) UNITS, FOR A LADING WEIGHT OF 76,572 POUNDS, CAN BE OUTLOADED IN A 40'-6" LONG CAR.
3. THE DEPICTED LOADING PATTERN IS ADEQUATE FOR CARS HAVING DOOR OPENINGS AS NARROW AS 8'-0". IF THE CAR TO BE LOADED HAS DOOR OPENINGS LESS THAN 8'-0" WIDE AND NOT OF SUFFICIENT HEIGHT TO ALLOW PERSONNEL TO EXIT THE CAR OVER THE TOP OF THE LOAD, THE LENGTHWISE UNITS SHOULD BE LOADED SIX (6) STACKS LONG IN EACH END OF THE CAR AND THE CROSSWISE STACKS SHOULD BE LOADED EIGHT (8) STACKS LONG IN EACH END. PIECE MARKED ⑦ WILL NOT BE REQUIRED; THE BALANCE OF THE DUNNAGE WILL NOT CHANGE.
4. THE "HIGH" CRIB, SHOWN AS PIECE MARKED ①, MUST BE INSTALLED IN EACH END OF THE LOAD. FOUR (4) ASSEMBLIES ARE REQUIRED IN EACH END OF A LOAD REGARDLESS OF THE CAR LENGTH.
5. THE SEPARATOR GATES, SHOWN AS PIECES MARKED ② IN THE LOAD ON PAGE 34, ARE DESIGNATED "RIGHT HAND" AND "LEFT HAND" TO FACILITATE POSITIONING OF THE PALLET UNITS AS LOADING PROGRESSES. WHEN LOADING THE CAR, POSITION A PALLET UNIT STACK AGAINST THE END WALL, THEN POSITION A SEPARATOR GATE SO THE 1" X 4" TIE PIECES ARE LOCATED UNDER THE "OVERHANG" OF THE BOTTOM AND TOP PALLET UNITS IN THE FIRST STACK. REPEAT THIS PROCEDURE FOR THE REMAINING STACKS.
6. ALL SEPARATOR GATES WHICH ARE WITHIN THE DOORWAY AREA OF A CAR EQUIPPED WITH CONVENTIONAL SLIDING DOORS MUST BE WIRE TIED TO THE ADJACENT CRIB FILL TO PREVENT DISPLACEMENT. ENCIRCLE THE STOP PIECE OF THE SEPARATOR GATE AND THE UPPER HORIZONTAL PIECE OF THE CRIB FILL WITH NO. 14 GAGE WIRE AND TWIST TAUT.
7. SEPARATOR GATES MAY BE FORMED FROM 3/8" OR THICKER PLYWOOD IN LIEU OF DIMENSIONAL LUMBER, IF DESIRED. CONSTRUCT EACH GATE 43" WIDE BY 8'-0" LONG.
8. CENTER GATES "J" AND "K" MAY BE PARTIALLY FORMED FROM 1/2" OR THICKER PLYWOOD, IF DESIRED. PLYWOOD MAY BE USED IN LIEU OF THE 2" X 6" HORIZONTAL PIECES. SEE THE "PLYWOOD CENTER GATE ALTERNATIVE" DETAIL ON PAGE 123 FOR GUIDANCE.
9. DOORWAY PROTECTION IS REQUIRED FOR ALL PALLET UNIT STACKS WHICH ARE COMPLETELY WITHIN THE DOORWAY AREA OR WHICH EXTEND INTO THE DOORWAY AREA BY ONE-HALF OR MORE OF THE STACK WIDTH OR LENGTH. THE WOODEN GATE TYPE OF DOORWAY PROTECTION, SHOWN AS PIECES MARKED ⑪ AND ⑫ IN THE LOAD ON PAGE 34, IS APPLICABLE FOR BOX CARS EQUIPPED WITH CONVENTIONAL SLIDING DOORS AND NAILABLE DOOR POSTS. REFER TO PAGES 126 THRU 128 FOR ALTERNATIVE DOORWAY PROTECTION FOR CARS EQUIPPED WITH CONVENTIONAL SLIDING DOORS. IF THE CAR BEING LOADED IS EQUIPPED WITH PLUG TYPE DOORS, NAILED FLOORLINE BLOCKING AND LOAD-BUNDLING STRAPS MUST BE USED. SEE THE "ALTERNATIVE DOORWAY PROTECTION E" AND "ALTERNATIVE DOORWAY PROTECTION F" DETAILS ON PAGE 128 FOR GUIDANCE; A COMBINATION OF THE TWO METHODS MUST BE USED. NAILED SIDE BLOCKING, DOUBLED 2" X 4" X 7'-6" LONG, WILL BE USED UNDER THE CRIB FILL SHOWN IN THE DOORWAY AREA OF THE LOAD. POSITION ONE SIDE BLOCKING ADJACENT TO THE CROSSWISE STACKS NUMBERED 8 AND 9 AND ONE DIRECTLY OPPOSITE AGAINST ALL OR A PORTION OF THE LENGTHWISE STACKS NUMBERED 6 AND 7. THESE PIECES WILL BE USED IN LIEU OF THE 40" AND 48" LONG PIECES SHOWN BY THE ALTERNATIVE DETAILS A SPACER ASSEMBLY, AS SHOWN IN THE "ALTERNATIVE DOORWAY PROTECTION F" DETAIL, MUST BE MODIFIED FOR USE BY CHANGING THE END WHICH EXTENDS OVER THE CROSSWISE CONTAINERS TO BE LIKE THE NEAR END OF THE STRAPPING BOARD SHOWN IN THE "ALTERNATIVE DOORWAY PROTECTION E" DETAIL. A 2" X 4" X 40" DOUBLED BATTEN AS SHOWN IN THAT VIEW IS ALSO REQUIRED. NOTE THAT THE VERTICAL PIECES AND BOTTOM SUPPORT PIECES OF THE CRIB FILL, PIECES MARKED ③, MUST HAVE THREE INCHES (3") CUT OFF THE BOTTOM END OF ONE SIDE SO THE CRIB WILL REST EVENLY ON THE NAILED SIDE BLOCKING WHICH IS ADJACENT TO THE LENGTHWISE UNITS. ALSO NOTE THAT THE SIDE BLOCKING FOR THE CROSSWISE UNITS MUST BE PRE-POSITIONED APPROXIMATELY FIFTY-TWO INCHES (52") FROM THE NEAR SIDE CAR WALL, AND THE CENTER GATE "J" WHICH IS IN THE DOORWAY MUST BE WIRE TIED TO PIECE MARKED ⑥ TO PREVENT DISPLACEMENT.
10. THE DEPICTED LOAD CAN BE REDUCED TO SUIT THE QUANTITY TO BE SHIPPED. A 2-TIER LOAD CAN BE REDUCED BY ONE OR MORE PALLET UNITS BY EMPLOYING THE PROCEDURES ON PAGE 96. FOUR (4) UNITS CAN BE OMITTED FROM A 2-TIER LOAD BY LEAVING OUT THE LENGTHWISE STACKS NO. 7 AND THE CROSSWISE STACK NO. 9. NOTE THAT STRUT BRACING WILL THEN BE REQUIRED. OR, THE ENTIRE TOP TIER CAN BE OMITTED. A PARTIAL 1-TIER LOAD CAN BE SHIPPED IN ONE OR BOTH ENDS OF A CAR BY USING KNEE BRACES AS SHOWN ON PAGES 112 AND 113.

(CONTINUED AT LEFT)

**LOAD AS SHOWN**

ITEM	QUANTITY	WEIGHT (APPROX)
PALLET UNITS	56	119,112 LBS
DUNNAGE		1,809 LBS
<b>TOTAL WEIGHT</b>		<b>120,921 LBS</b>

FLAT DUNNAGE METHOD UNIT (BASIC HEIGHT)  
56-UNIT LOAD IN A 60'-8" LONG BY 9'-2" WIDE CONVENTIONAL BOX CAR

DIRECTION OF ARROW INDICATES BASE END OF CONTAINERS. SEE GENERAL NOTE "E" ON PAGE 2.

ONE LOAD UNIT

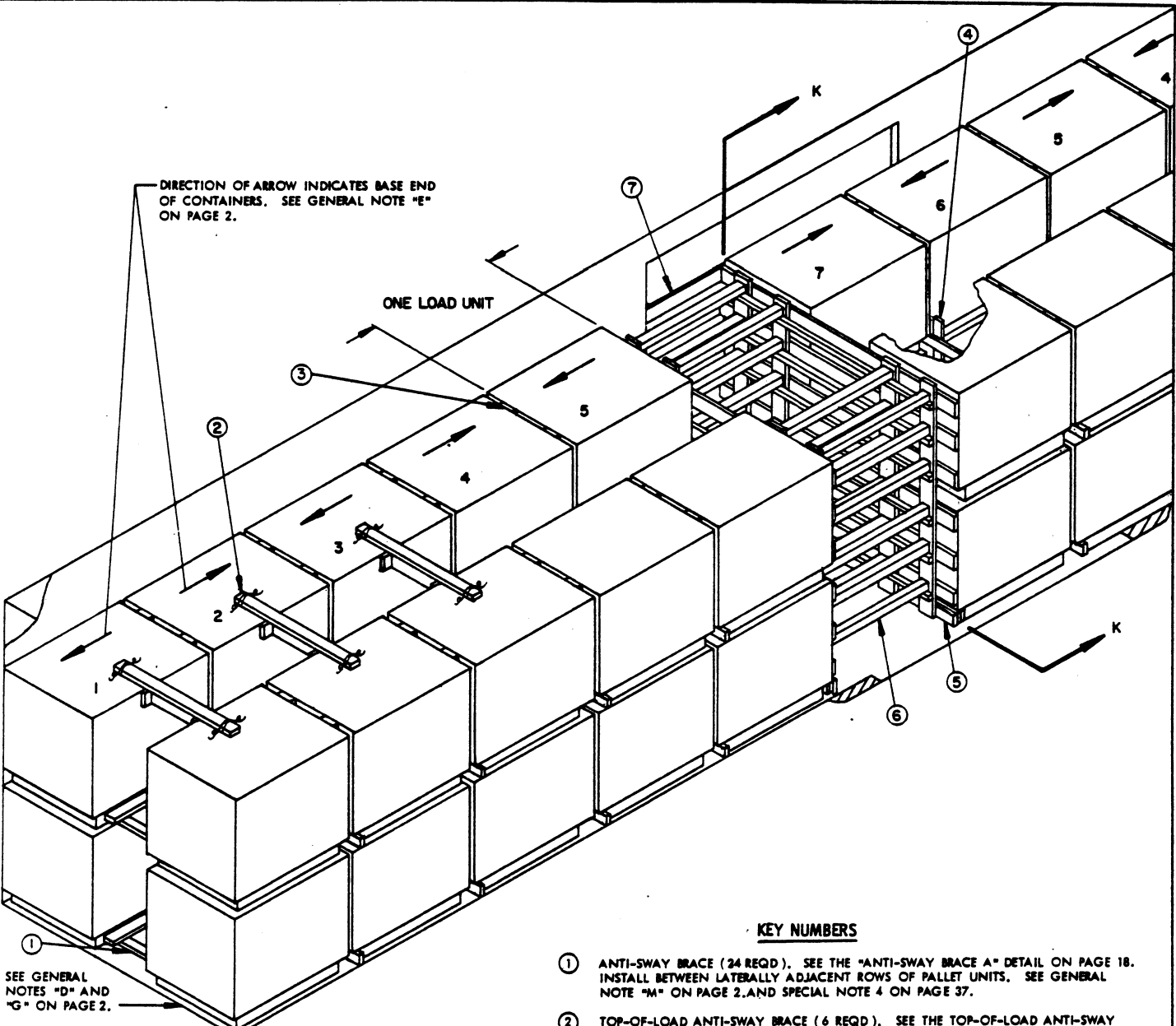

SEE GENERAL NOTES "D" AND "G" ON PAGE 2.

ISOMETRIC VIEW

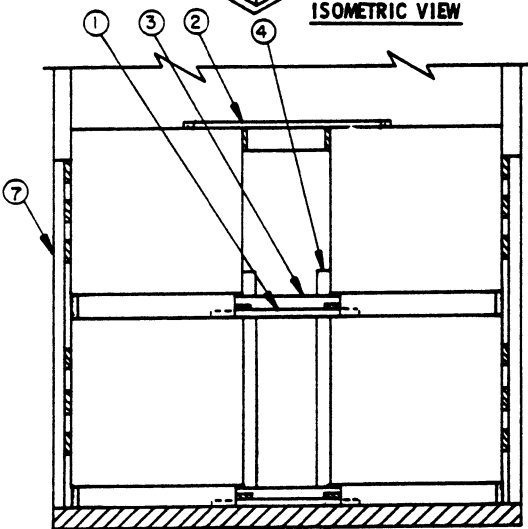

SECTION K-K

**KEY NUMBERS**

- ① ANTI-SWAY BRACE (24 REQD). SEE THE "ANTI-SWAY BRACE A" DETAIL ON PAGE 18. INSTALL BETWEEN LATERALLY ADJACENT ROWS OF PALLET UNITS. SEE GENERAL NOTE "M" ON PAGE 2 AND SPECIAL NOTE 4 ON PAGE 37.
- ② TOP-OF-LOAD ANTI-SWAY BRACE (6 REQD). SEE THE TOP-OF-LOAD ANTI-SWAY BRACE B" DETAIL ON PAGE 46. WIRE TIE TO STRAPPING BOARDS OF UNIT WITH NO. 14 GAGE WIRE AS TYPICALLY SHOWN BY THE "TIE WIRE APPLICATION B" DETAIL ON PAGE 122. SEE SPECIAL NOTE 5 ON PAGE 37.
- ③ SEPARATOR GATE (10 REQD). SEE THE "SEPARATOR GATE F" DETAIL ON PAGE 45. POSITION WITH THE HORIZONTAL PIECES AGAINST THE ALREADY-LOADED UNITS. SEE SPECIAL NOTES 6 AND 8 ON PAGE 37.
- ④ STOP PIECE, 1" X 4" X 60" (2 REQD). INSTALL ON THE SIDE OPPOSITE THE VERTICAL PIECES OF THE SEPARATOR GATE, PIECE MARKED ③, WHICH IS IN THE DOORWAY AREA. POSITION IN CONTACT WITH THE ADJACENT PALLET UNITS AND NAIL TO THE HORIZONTAL PIECES W/3-6d NAILS AT EACH JOINT AND CLINCH. SEE SPECIAL NOTE 7 ON PAGE 37.
- ⑤ CENTER GATE (2 REQD). SEE THE "CENTER GATE L" DETAIL ON PAGE 46. SEE SPECIAL NOTES 9, 10, AND 11 ON PAGE 37.
- ⑥ STRUT, 4" X 4" BY CUT TO FIT (REF: 48") (24 REQD). TOENAIL TO PIECES MARKED ③ W/2-16d NAILS AT EACH END. SEE GENERAL NOTES "L", "S", AND "T" ON PAGE 2.
- ⑦ DOORWAY PROTECTION (2 REQD). SEE THE "DOORWAY PROTECTION D" DETAIL ON PAGE 46. NAIL TO THE DOOR POSTS W/12d NAILS. SEE SPECIAL NOTE 12 ON PAGE 37.

FLAT DUNNAGE METHOD UNIT ( BASIC HEIGHT )  
48-UNIT LOAD IN A 60'-8" LONG BY 9'-2" WIDE CONVENTIONAL BOX CAR

( SPECIAL NOTES CONTINUED )

- 13. IF THE ALTERNATIVE DOORWAY PROTECTION "F" PROCEDURES SHOWN ON PAGE 128 ARE USED IN LIEU OF THE WOODEN DOORWAY PROTECTION PIECES MARKED ⑦, THE CENTER GATES MUST BE RESTRAINED FROM LATERAL MOVEMENT. THIS CAN BE ACCOMPLISHED BY NAILING TO THE CAR FLOOR A DOUBLED 2" X 4" X 18" PIECE POSITIONED LONGITUDINALLY SO AS TO BE CENTERED AGAINST THE FULL PIECE OF A CENTER GATE. TWO (2) PIECES WILL BE REQUIRED FOR EACH CENTER GATE WHICH IS IN THE DOOR OPENING OR WITHIN SIX INCHES (6") OF BEING IN THE DOOR OPENING.
- 14. THE DEPICTED LOAD CAN BE REDUCED TO SUIT THE QUANTITY TO BE SHIPPED. A 2-TIER LOAD CAN BE REDUCED BY A MULTIPLE OF FOUR (4) PALLET UNITS OR A 1-TIER LOAD CAN BE REDUCED BY A MULTIPLE OF TWO (2) UNITS BY OMITTING ONE OR MORE LOAD UNITS FROM THE CENTER PORTION OF THE LOAD. OR, THE ENTIRE TOP TIER CAN BE OMITTED. FOR OTHER METHODS OF REDUCING A LOAD, AND FOR TYPICAL LCL PROCEDURES, REFER TO PAGES 92 THRU 120 FOR GUIDANCE.
- 15. IF PALLET UNITS WHICH DO NOT CONTAIN A FULL QUANTITY OF CONTAINERS ARE TO BE TRANSPORTED, REFER TO PAGE 117 FOR SHIPPING GUIDANCE.
- 16. FOR SHIPMENT OF ONE OR MORE LEFTOVER CONTAINERS, SEE THE "PROCEDURES FOR SHIPMENT OF LEFTOVER CONTAINERS" ON PAGE 119 FOR GUIDANCE.

SPECIAL NOTES:

- 1. A 60'-8" LONG BY 9'-2" WIDE WOOD-LINED CONVENTIONAL TYPE BOX CAR EQUIPPED WITH 10'-0" WIDE DOOR OPENINGS IS SHOWN. CARS OF OTHER DIMENSIONS AND CARS HAVING WIDER OR NARROWER DOOR OPENINGS CAN BE USED. SEE GENERAL NOTE "D" ON PAGE 2 AND SPECIAL NOTE 3 BELOW.
- 2. THE PALLETIZED UNIT SHOWN IN THE TYPICAL LOAD ON PAGE 36 IS THE FLAT DUNNAGE METHOD UNIT (BASIC HEIGHT). A MAXIMUM OF FORTY (40) OF THESE UNITS, FOR AN APPROXIMATE LADING WEIGHT OF 85,080 POUNDS, CAN BE PLACED IN A 50'-6" LONG CAR WHEN USING THE DEPICTED PROCEDURES; THIRTY-TWO (32) UNITS, FOR AN APPROXIMATE LADING WEIGHT OF 68,064 POUNDS, CAN BE OUTLOADED IN A 40'-6" LONG CAR.
- 3. THE DEPICTED LOADING PATTERN IS ADEQUATE FOR CARS HAVING DOOR OPENINGS 8' THRU 10' OR WIDER. IF THE CAR TO BE LOADED HAS DOOR OPENINGS LESS THAN 8'-0" WIDE AND NOT OF SUFFICIENT HEIGHT TO ALLOW PERSONNEL TO EXIT THE CAR OVER THE TOP OF THE LOAD, THE PALLETS SHOULD BE POSITIONED SO THERE ARE SIX (6) LOAD UNITS IN EACH END. NOTE THAT ALTHOUGH CARS HAVING DOOR OPENINGS AS NARROW AS 6'-0" WIDE CAN BE USED FOR FULL LOADS, LOADING IS PROGRESSIVELY MORE DIFFICULT AS THE WIDTH OF THE DOOR OPENING DECREASES.
- 4. IF THE "ALTERNATIVE DOORWAY PROTECTION F" PROCEDURES AS SHOWN ON PAGE 128 ARE USED IN LIEU OF THE WOODEN DOOR GATE TYPE PROTECTION, PIECE MARKED ⑦, NAILED FLOORLINE BLOCKING MUST BE USED IN LIEU OF EACH LOWER ANTI-SWAY BRACE IN THE DOORWAY AREA. NAILED BLOCKING IS REQUIRED FOR ALL PALLET STACKS WHICH ARE COMPLETELY WITHIN THE DOORWAY AREA OR WHICH EXTEND INTO THE DOORWAY AREA BY ONE-HALF OR MORE OF THE STACK WIDTH ON EITHER SIDE OF THE CAR.
- 5. TOP-OF-LOAD ANTI-SWAY BRACES, SHOWN AS PIECES MARKED ② IN THE LOAD ON PAGE 36, MUST BE INSTALLED IN EACH END OF THE CAR AND WIRE TIED TO A STRAPPING BOARD WITH NO. 14 GAGE WIRE AS TYPICALLY SHOWN BY THE "TIE WIRE APPLICATION B" DETAIL ON PAGE 122. THREE (3) BRACES ARE REQUIRED IN EACH END OF A LOAD REGARDLESS OF THE CAR LENGTH.
- 6. TO FACILITATE POSITIONING OF THE PALLET UNITS AS LOADING PROGRESSES, POSITION PALLET UNIT STACKS AGAINST THE END WALL, THEN POSITION A SEPARATOR GATE, SHOWN AS PIECE MARKED ③, SO THE 1" X 4" TIE PIECES ARE LOCATED UNDER THE "OVERHANG" OF THE PALLET UNITS. REPEAT THIS PROCEDURE FOR THE REMAINING STACKS.
- 7. SEPARATOR GATES IN THE DOORWAY MUST BE PREVENTED FROM SHIFTING INTO A DOOR OPENING BY THE APPLICATION OF THE STOP PIECES, PIECES MARKED ④ IN CARS EQUIPPED WITH STAGGERED DOORS, STOP PIECES MAY BE REQUIRED ON UP TO FOUR SEPARATOR GATES.
- 8. SEPARATOR GATES MAY BE FORMED FROM 3/8" OR THICKER PLYWOOD IN LIEU OF DIMENSIONAL LUMBER, IF DESIRED. SEE THE "ALTERNATIVE SEPARATOR GATE" DETAIL ON PAGE 122 FOR CONSTRUCTION GUIDANCE.
- 9. CENTER GATE "L" MAY BE PARTIALLY FORMED FROM 1/2" OR THICKER PLYWOOD, IF DESIRED. PLYWOOD MAY BE USED IN LIEU OF THE 2" X 6" HORIZONTAL PIECES. SEE THE "PLYWOOD CENTER GATE ALTERNATIVE" DETAIL ON PAGE 123 FOR GUIDANCE.
- 10. FOR EASE OF HANDLING, SPLIT CENTER GATES, WHICH ARE NOT DEPENDENT UPON THE WIDTH OF THE CAR, MAY BE USED AS AN ALTERNATIVE TO THE CAR-WIDTH GATES. IN LIEU OF EACH "CENTER GATE L" SHOWN AS PIECE MARKED ③ IN THE LOAD ON PAGE 36, INSTALL TWO (2) "CENTER GATES J" AS SHOWN ON PAGE 44. AFTER THE SPLIT GATES AND STRUTS HAVE BEEN INSTALLED, THE SPLIT GATES MUST BE TIED TOGETHER AS DEPICTED BY THE "TIE PIECE APPLICATION" DETAIL ON PAGE 123. OMIT THE STOP PIECES FROM "CENTER GATE J".
- 11. DOOR SPANNER TYPE GATE HOLD DOWN MAY BE USED IN LIEU OF THE DOUBLED 2" X 4" MATERIAL NAILED TO CENTER GATE "L", PROVIDING THE CAR BEING LOADED HAS NAILABLE SIDEWALLS. SEE THE DETAILS ON PAGE 125 FOR GUIDANCE.
- 12. DOORWAY PROTECTION IS REQUIRED FOR ALL PALLET UNIT STACKS WHICH ARE COMPLETELY WITHIN THE DOORWAY AREA OR WHICH EXTEND INTO THE DOORWAY AREA BY ONE-HALF OR MORE OF THE STACK WIDTH. THE WOODEN GATE TYPE OF DOORWAY PROTECTION, SHOWN AS PIECE MARKED ⑦ IN THE LOAD ON PAGE 36, IS APPLICABLE FOR BOX CARS EQUIPPED WITH CONVENTIONAL SLIDING DOORS AND NAILABLE DOOR POSTS. REFER TO PAGES 126 THRU 128 FOR ALTERNATIVE DOORWAY PROTECTION FOR CARS EQUIPPED WITH CONVENTIONAL SLIDING DOORS. IF THE CAR BEING LOADED IS EQUIPPED WITH PLUG TYPE DOORS, NAILED FLOORLINE BLOCKING AND LOAD BUNDLING STRAPS MUST BE USED. SEE THE "ALTERNATIVE DOORWAY PROTECTION F" DETAIL ON PAGE 128 FOR GUIDANCE.

BILL OF MATERIAL		
LUMBER	LINEAR FEET	BOARD FEET
1" X 4"	193	65
1" X 6"	410	205
2" X 2"	94	32
2" X 3"	32	16
2" X 4"	359	240
2" X 6"	207	207
4" X 4"	100	134
NAILS	NO. REQD	POUNDS
6d (2")	400	2-1/2
10d (3")	1048	16-1/4
12d (3-1/4")	32	3/4
16d (3-1/2")	96	2-1/4
WIRE, NO. 14 GAGE-----60' REQD-----1 LB		

( CONTINUED AT LEFT )

LOAD AS SHOWN

ITEM	QUANTITY	WEIGHT ( APPROX )
PALLET UNITS -----	48 -----	102,096 LBS
DUNNAGE-----	-----	1,821 LBS
TOTAL WEIGHT -----		103,917 LBS

FLAT DUNNAGE METHOD UNIT ( BASIC HEIGHT )  
48-UNIT LOAD IN A 60'-8" LONG BY 9'-2" WIDE CONVENTIONAL BOX CAR

DIRECTION OF ARROW INDICATES BASE END OF CONTAINERS. SEE GENERAL NOTE "E" ON PAGE 2.

SEE SPECIAL NOTE 3 ON PAGE 39.

ONE LOAD UNIT

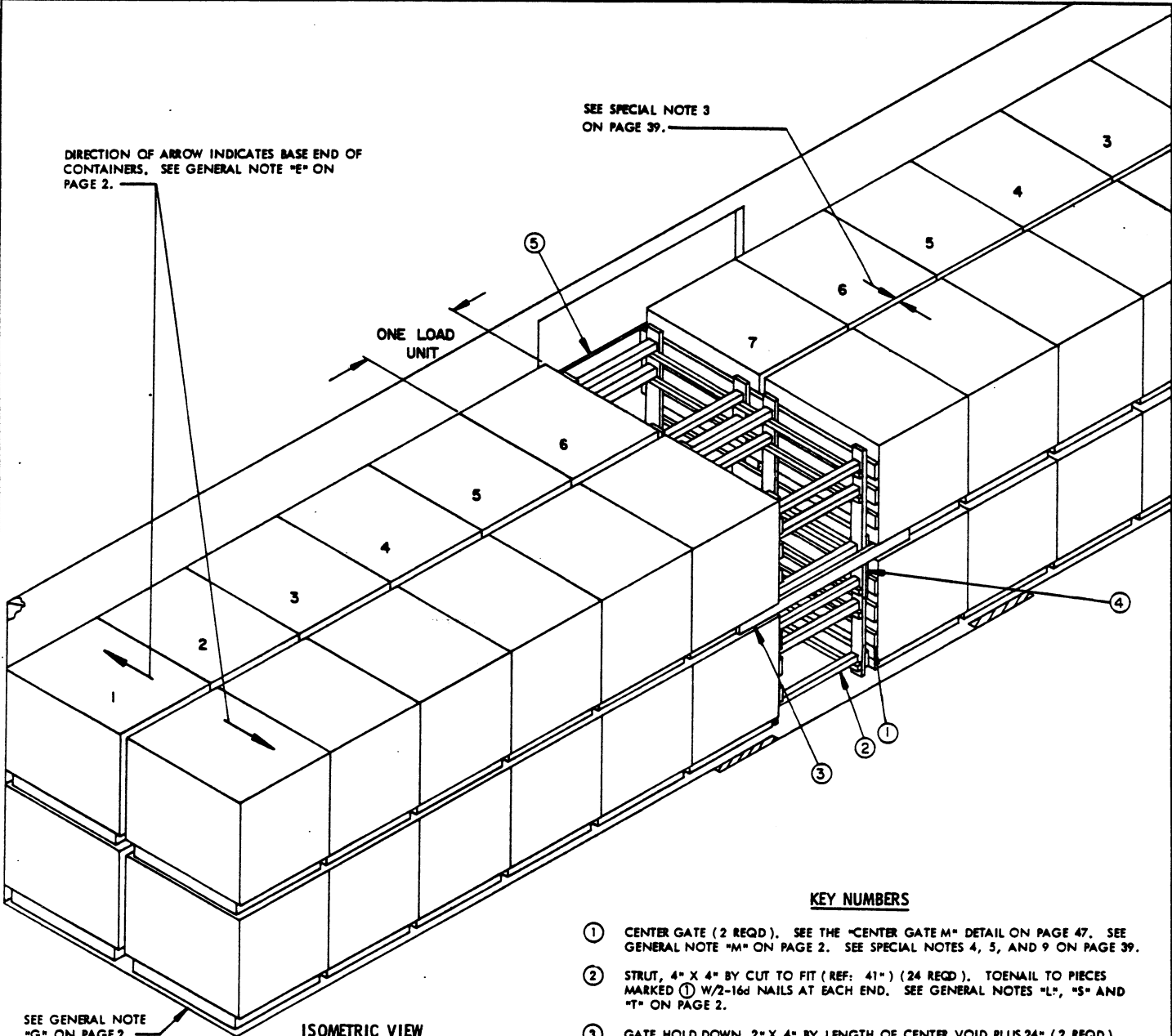

SEE GENERAL NOTE "G" ON PAGE 2.

**ISOMETRIC VIEW**

**KEY NUMBERS**

- ① CENTER GATE (2 REQD). SEE THE "CENTER GATE M" DETAIL ON PAGE 47. SEE GENERAL NOTE "M" ON PAGE 2. SEE SPECIAL NOTES 4, 5, AND 9 ON PAGE 39.
- ② STRUT, 4" X 4" BY CUT TO FIT (REF: 41") (24 REQD). TOENAIL TO PIECES MARKED ① W/2-16d NAILS AT EACH END. SEE GENERAL NOTES "L", "S" AND "T" ON PAGE 2.
- ③ GATE HOLD DOWN, 2" X 4" BY LENGTH OF CENTER VOID PLUS 24" (2 REQD). POSITION UNDER THE ENDS OF THE CONTAINERS AND NAIL TO THE VERTICAL PIECES OF THE CENTER GATES W/2-10d NAILS AT EACH JOINT. SEE SPECIAL NOTE 6 ON PAGE 39.
- ④ GATE HOLD DOWN SUPPORT PIECE 2" X 2" X 15" (4 REQD). POSITION UNDER PIECE MARKED ③ AND NAIL TO A VERTICAL PIECE OF PIECE MARKED ① W/4-10d NAILS.
- ⑤ DOORWAY PROTECTION (2 REQD). SEE THE "DOORWAY PROTECTION E" DETAIL ON PAGE 47. NAIL TO THE DOOR POSTS W/12d NAILS. SEE SPECIAL NOTE 7 ON PAGE 39.

**SPECIAL NOTES:**

1. A 50'-6" LONG BY 9'-4" WIDE WOOD-LINED CONVENTIONAL TYPE BOX CAR EQUIPPED WITH 8'-0" WIDE DOOR OPENINGS IS SHOWN. WIDER CARS OF OTHER LENGTHS AND CARS HAVING WIDER OR NARROWER DOOR OPENINGS CAN BE USED. SEE GENERAL NOTE "D" ON PAGE 2.
2. THE PALLETIZED UNIT SHOWN IN THE TYPICAL LOAD ON PAGE 38 IS THE FLAT DUNNAGE METHOD UNIT (BASIC HEIGHT). A MAXIMUM OF FORTY (40) OF THESE UNITS, FOR AN APPROXIMATE LADING WEIGHT OF 85,080 POUNDS, CAN BE PLACED IN A 40'-6" LONG CAR WHEN USING THE DEPICTED PROCEDURES. IF A 60'-8" LONG BY 9'-4" OR WIDER CAR IS AVAILABLE, SIXTY-FOUR (64) PALLET UNITS FOR AN APPROXIMATE LADING WEIGHT OF 136,128 POUNDS CAN BE LOADED. NOTE THAT EIGHT (8) STRUTS ARE REQUIRED FOR EACH ROW/LAYER IN A 60' CAR; SEE THE PHANTOMED STRUT LEDGERS WHICH MUST BE ADDED TO THE GATES, AS SHOWN ON THE "CENTER GATE M" DETAIL ON PAGE 47.
3. ANTI-SWAY BRACING BETWEEN LATERALLY ADJACENT ROWS OF PALLET UNITS IS NOT REQUIRED REGARDLESS OF THE WIDTH OF THE CAR BEING LOADED.
4. CENTER GATE "M" MAY BE PARTIALLY FORMED FROM 1/2" OR THICKER PLYWOOD, IF DESIRED. PLYWOOD MAY BE USED IN LIEU OF THE 2" X 6" HORIZONTAL PIECES. SEE THE "PLYWOOD CENTER GATE ALTERNATIVE" DETAIL ON PAGE 123 FOR GUIDANCE.
5. FOR EASE OF HANDLING, SPLIT CENTER GATES, WHICH ARE NOT DEPENDENT UPON THE WIDTH OF THE CAR, MAY BE USED AS AN ALTERNATIVE TO THE CAR-WIDTH GATES. IN LIEU OF EACH "CENTER GATE M" SHOWN AS PIECE MARKED ① IN THE LOAD ON PAGE 38, INSTALL TWO (2) "CENTER GATES K" AS SHOWN ON PAGE 45. AFTER THE SPLIT GATES AND STRUTS HAVE BEEN INSTALLED, THE SPLIT GATES MUST BE TIED TOGETHER AS DEPICTED BY THE "TIE PIECE APPLICATION" DETAIL ON PAGE 123.
6. AN ALTERNATIVE TO THE GATE HOLD DOWN SHOWN AS PIECE MARKED ② IN THE LOAD ON PAGE 38 MAY BE USED, IF DESIRED, WHEN THE CAR FURNISHED FOR LOADING IS EQUIPPED WITH 8'-0" OR WIDER DOORS. AN ALTERNATIVE MUST BE USED WHEN THE CAR FURNISHED HAS DOOR OPENINGS LESS THAN 8'-0" WIDE. DOOR SPANNER TYPE HOLD DOWN AS SHOWN BY THE DETAILS ON PAGE 125 MAY BE USED IF THE CAR HAS NAILABLE SIDEWALLS, OR HOLD DOWN PIECES MAY BE APPLIED TO THE CENTER GATES AS SHOWN BY THE CENTER GATE "M" DETAIL ON PAGE 47.
7. DOORWAY PROTECTION IS REQUIRED FOR ALL PALLET UNIT STACKS WHICH ARE COMPLETELY WITHIN THE DOORWAY AREA OR WHICH EXTEND INTO THE DOORWAY AREA BY ONE-HALF OR MORE OF THE STACK LENGTH. THE WOODEN GATE TYPE OF DOORWAY PROTECTION, SHOWN AS PIECES MARKED ③ IN THE LOAD ON PAGE 38, IS APPLICABLE FOR BOX CARS EQUIPPED WITH CONVENTIONAL SLIDING DOORS AND NAILABLE DOOR POSTS. REFER TO PAGES 126 THRU 128 FOR ALTERNATIVE DOORWAY PROTECTION FOR CARS EQUIPPED WITH CONVENTIONAL SLIDING DOORS. IF THE CAR BEING LOADED IS EQUIPPED WITH PLUG TYPE DOORS, NAILABLE FLOOR-LINE BLOCKING AND LOAD BUNDLING STRAPS MUST BE USED. SEE THE "ALTERNATIVE DOORWAY PROTECTION E" DETAIL ON PAGE 128 FOR GUIDANCE.
8. THE DEPICTED LOAD CAN BE REDUCED TO SUIT THE QUANTITY TO BE SHIPPED. A 2-TIER LOAD CAN BE REDUCED BY A MULTIPLE OF FOUR (4) PALLET UNITS OR A 1-TIER LOAD CAN BE REDUCED BY A MULTIPLE OF TWO (2) UNITS BY OMITTING ONE OR MORE LOAD UNITS FROM THE CENTER PORTION OF THE LOAD. OR, THE ENTIRE TOP TIER CAN BE OMITTED. FOR OTHER METHODS OF REDUCING A LOAD, AND FOR TYPICAL LCL PROCEDURES, REFER TO PAGES 92 THRU 120 FOR GUIDANCE.
9. IF A FULL LOAD IS TO BE SHIPPED IN A 60' LONG CAR, EIGHT (8) STRUTS WILL BE REQUIRED PER ROW/TIER. TO ACCOMMODATE THESE ADDITIONAL STRUTS, A STRUT LEDGER MUST BE ADDED TO CENTER GATE "M" FOR EACH TIER AS SHOWN BY THE PHANTOMED LINES ON THE DETAIL ON PAGE 47.
10. IF PALLETIZED UNITS WHICH DO NOT CONTAIN A FULL QUANTITY OF CONTAINERS ARE TO BE TRANSPORTED, REFER TO PAGES 118 AND 120 FOR SHIPPING GUIDANCE.
11. FOR SHIPMENT OF ONE OR MORE LEFTOVER CONTAINERS, SEE THE "PROCEDURES FOR SHIPMENT OF LEFTOVER CONTAINERS" ON PAGE 119 FOR GUIDANCE.

**BILL OF MATERIAL**

LUMBER	LINEAR FEET	BOARD FEET
1" X 6"	64	32
2" X 2"	110	37
2" X 3"	30	15
2" X 4"	12	8
2" X 6"	209	209
4" X 4"	82	110
NAILS	NO. REQD	POUNDS
6d (2")	48	1/2
10d (3")	304	4-3/4
12d (3-1/4")	32	3/4
16d (3-1/2")	96	2-1/4

**LOAD AS SHOWN**

ITEM	QUANTITY	WEIGHT (APPROX)
PALLET UNITS	52	110,604 LBS
DUNNAGE		831 LBS
		<b>TOTAL WEIGHT ---- 111,435 LBS</b>

FLAT DUNNAGE METHOD UNIT (BASIC HEIGHT)  
52-UNIT LOAD IN A 50'-6" LONG BY 9'-4" WIDE CONVENTIONAL BOX CAR

**CAR EQUIPMENT REQUIRED**

ADJUSTABLE WALL MEMBER (SEE "NOTE ①" BELOW)	48
CROSS MEMBER	27
DOORWAY MEMBER	12

NOTE ①: FOR CARS EQUIPPED WITH FIXED WALL MEMBERS LOCATED AT THE HEIGHTS SPECIFIED IN "SECTION L-L", OMIT ALL REFERENCE TO "ADJUSTABLE WALL MEMBERS".

DIRECTION OF ARROW INDICATES BASE END OF CONTAINERS. SEE GENERAL NOTE "E" ON PAGE 2.

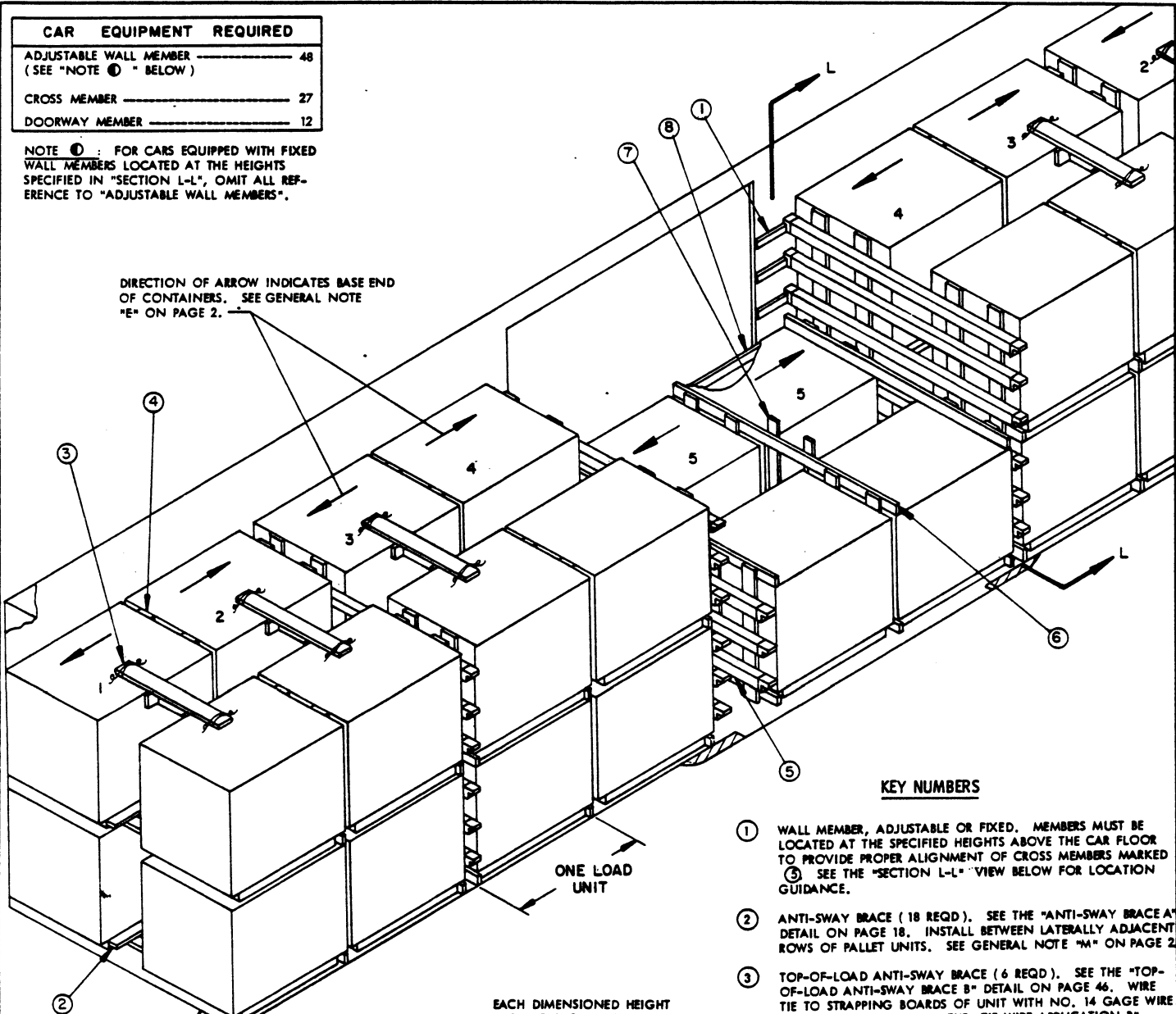

SEE GENERAL NOTES "D" AND "G" ON PAGE 2 AND SPECIAL NOTE 3 ON PAGE 41.

**ISOMETRIC VIEW**

EACH DIMENSIONED HEIGHT ABOVE THE CAR FLOOR TO AN ADJUSTABLE OR FIXED WALL MEMBER MARKED ① AND/OR A DOORWAY MEMBER MARKED ⑧ IS SPECIFIED TO LOCATE THE CENTER LINE OF A CROSS MEMBER.

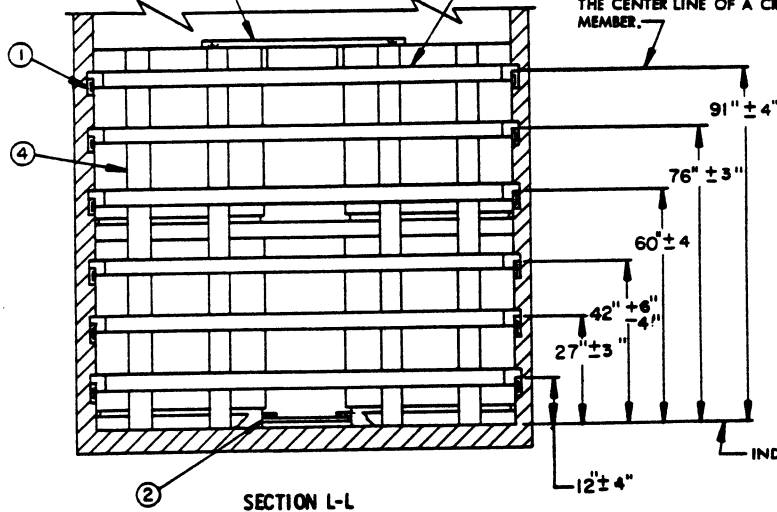

**SECTION L-L**

**KEY NUMBERS**

- ① WALL MEMBER, ADJUSTABLE OR FIXED. MEMBERS MUST BE LOCATED AT THE SPECIFIED HEIGHTS ABOVE THE CAR FLOOR TO PROVIDE PROPER ALIGNMENT OF CROSS MEMBERS MARKED ⑤. SEE THE "SECTION L-L" VIEW BELOW FOR LOCATION GUIDANCE.
- ② ANTI-SWAY BRACE (18 REQD). SEE THE "ANTI-SWAY BRACE A" DETAIL ON PAGE 18. INSTALL BETWEEN LATERALLY ADJACENT ROWS OF PALLET UNITS. SEE GENERAL NOTE "M" ON PAGE 2.
- ③ TOP-OF-LOAD ANTI-SWAY BRACE (6 REQD). SEE THE "TOP-OF-LOAD ANTI-SWAY BRACE B" DETAIL ON PAGE 46. WIRE TIE TO STRAPPING BOARDS OF UNIT WITH NO. 14 GAGE WIRE AS TYPICALLY SHOWN BY THE "TIE WIRE APPLICATION B" DETAIL ON PAGE 122. SEE SPECIAL NOTE 4 ON PAGE 41.
- ④ SEPARATOR GATE FOR 2-HIGH (10 REQD). SEE THE "SEPARATOR GATE F" DETAIL ON PAGE 45. AS APPLICABLE, POSITION WITH THE HORIZONTAL PIECES AGAINST THE ALREADY-LOADED UNITS. SEE SPECIAL NOTES 5 AND 7 ON PAGE 41.
- ⑤ CROSS MEMBER (27 REQD). SEE GENERAL NOTE "W" ON PAGE 3.
- ⑥ SEPARATOR GATE FOR 1-HIGH (3 REQD). SEE THE "SEPARATOR GATE F" DETAIL ON PAGE 45. AS APPLICABLE, POSITION WITH THE HORIZONTAL PIECES AGAINST THE ALREADY-LOADED UNITS. SEE SPECIAL NOTES 5 AND 7 ON PAGE 41.
- ⑦ STOP PIECE, 1" X 4" X 57" (4 REQD). POSITION AGAINST PALLET UNITS IN THE DOORWAY AREA AND NAIL TO THE HORIZONTAL PIECES OF PIECE MARKED ⑥ W/3-6d NAILS AT EACH JOINT AND CLINCH. SEE SPECIAL NOTE 6 ON PAGE 41.
- ⑧ DOORWAY MEMBER (6 REQD). SEE THE "SECTION L-L" VIEW AT LEFT FOR LOCATION GUIDANCE. SEE SPECIAL NOTE 8 ON PAGE 41.

**FLAT DUNNAGE METHOD UNIT (BASIC HEIGHT)**

**40-UNIT LOAD IN A 50'-6" LONG BY 9'-0" WIDE BOX CAR EQUIPPED MECHANICAL BRACING DEVICES**



**SPECIAL NOTES:**

1. A 50'-6" LONG BY 9'-0" WIDE (INSIDE CLEARANCE) WOOD-LINED BOX CAR EQUIPPED WITH ADJUSTABLE AND/OR FIXED WALL MEMBERS, AND WITH 10'-0" WIDE DOOR OPENINGS IS SHOWN. CARS OF OTHER DIMENSIONS AND CARS HAVING WIDER OR NARROWER DOOR OPENINGS CAN BE USED. SEE GENERAL NOTE "D" ON PAGE 2.
2. THE PALLET UNIT SHOWN IN THE TYPICAL LOAD ON PAGE 40 IS THE FLAT DUNNAGE METHOD UNIT (BASIC HEIGHT). A MAXIMUM OF TWENTY-EIGHT (28) OF THESE UNITS, FOR AN APPROXIMATE LADING WEIGHT OF 59,556 POUNDS, CAN BE PLACED IN A 40'-6" LONG CAR.
3. IF A CAR HAS BOWED END WALLS WHICH ARE BOWED OUTWARD TWO INCHES (2") OR MORE EITHER FROM SIDE-TO-SIDE OR FROM FLOOR-TO-ROOF, CROSS MEMBERS CAN BE INSTALLED NEAR THE END WALL OF THE CAR TO PROVIDE A "SQUARED END" RATHER THAN INSTALLING DUNNAGE AS SPECIFIED IN GENERAL NOTE "G" ON PAGE 2. THESE CROSS MEMBERS SHOULD BE INSTALLED AT THE SAME HEIGHTS AS THE CROSS MEMBERS USED THROUGHOUT THE LOAD AS BLOCKING MEMBERS. A SEPARATOR GATE SHOWN AS PIECE MARKED ④, MUST BE POSITIONED AGAINST THESE CROSS MEMBERS PRIOR TO LOADING.
4. TOP-OF-LOAD ANTI-SWAY BRACES, SHOWN AS PIECES MARKED ③ IN THE LOAD ON PAGE 40, MUST BE INSTALLED IN EACH END OF THE CAR AND WIRE TIED TO THE STRAPPING BOARDS WITH NO. 14 GAGE WIRE AS TYPICALLY SHOWN BY THE "TIE WIRE APPLICATION B" DETAIL ON PAGE 122. THREE (3) BRACES ARE REQUIRED IN EACH END OF A LOAD REGARDLESS OF THE CAR LENGTH.
5. TO FACILITATE POSITIONING OF THE PALLET UNITS AS LOADING PROGRESSES, POSITION PALLET UNIT STACKS AGAINST THE END WALL, THEN POSITION A SEPARATOR GATE, SHOWN AS PIECE MARKED ④, SO THE 1" X 4" TIE PIECES ARE LOCATED UNDER THE "OVERHANG" OF THE PALLET UNITS. REPEAT THIS PROCEDURE FOR THE REMAINING STACKS.
6. SEPARATOR GATES IN THE DOORWAY MUST BE PREVENTED FROM SHIFTING INTO A DOOR OPENING BY THE APPLICATION OF THE STOP PIECES, PIECES MARKED ⑦ IN CARS EQUIPPED WITH STAGGERED DOORS, STOP PIECES MAY BE REQUIRED ON UP TO FOUR SEPARATOR GATES.
7. SEPARATOR GATES MAY BE FORMED FROM 3/8" OR THICKER PLYWOOD IN LIEU OF DIMENSIONAL LUMBER, IF DESIRED. SEE THE "ALTERNATIVE SEPARATOR GATE" DETAIL ON PAGE 122 FOR CONSTRUCTION GUIDANCE.
8. IF THE CAR BEING LOADED IS EQUIPPED WITH AT LEAST TWELVE (12) DOORWAY MEMBERS, AN ADDITIONAL FOUR PALLET UNITS CAN BE LOADED IN THE DOORWAY AREA.
9. THE DEPICTED LOAD CAN BE REDUCED TO SUIT THE QUANTITY TO BE SHIPPED. A LOAD MAY BE REDUCED BY MULTIPLES OF TWO (2) PALLET UNITS BY OMITTING Laterally ADJACENT UNITS FROM THE TOP LAYER OF ONE OR MORE LOAD UNITS OR BY MULTIPLES OF FOUR (4) PALLET UNITS BY OMITTING ONE OR MORE ENTIRE LOAD UNITS. TO REDUCE A LOAD BY ONE (1) PALLET UNIT, REFER TO THE LCL PROCEDURES ON PAGES 90 AND 91 FOR GUIDANCE.
10. FOR SHIPMENT OF ONE OR MORE LEFTOVER CONTAINERS, SEE THE "PROCEDURES FOR SHIPMENT OF LEFTOVER CONTAINERS" ON PAGE 119 FOR GUIDANCE.

**BILL OF MATERIAL**

LUMBER	LINEAR FEET	BOARD FEET
1" X 4"	252	84
1" X 6"	387	194
2" X 4"	255	170
2" X 6"	19	19
NAILS	NO. REQD	POUNDS
6d (2")	336	2
10d (3")	300	4-3/4
WIRE, NO. 14 GAGE -----60' REQD-----1 LB		

**LOAD AS SHOWN**

ITEM	QUANTITY	WEIGHT (APPROX)
PALLET UNIT	36	76,572 LBS
DUNNAGE		942 LBS
TOTAL WEIGHT		77,514 LBS

FLAT DUNNAGE METHOD UNIT (BASIC HEIGHT)  
 40-UNIT LOAD IN A 50'-6" LONG BY 9'-0" WIDE BOX CAR EQUIPPED WITH MECHANICAL BRACING DEVICES

DIRECTION OF ARROW INDICATES BASE END OF CONTAINERS. SEE GENERAL NOTE "E" ON PAGE 2.

INDICATES A LOAD DIVIDER BULKHEAD.

ONE LOAD UNIT

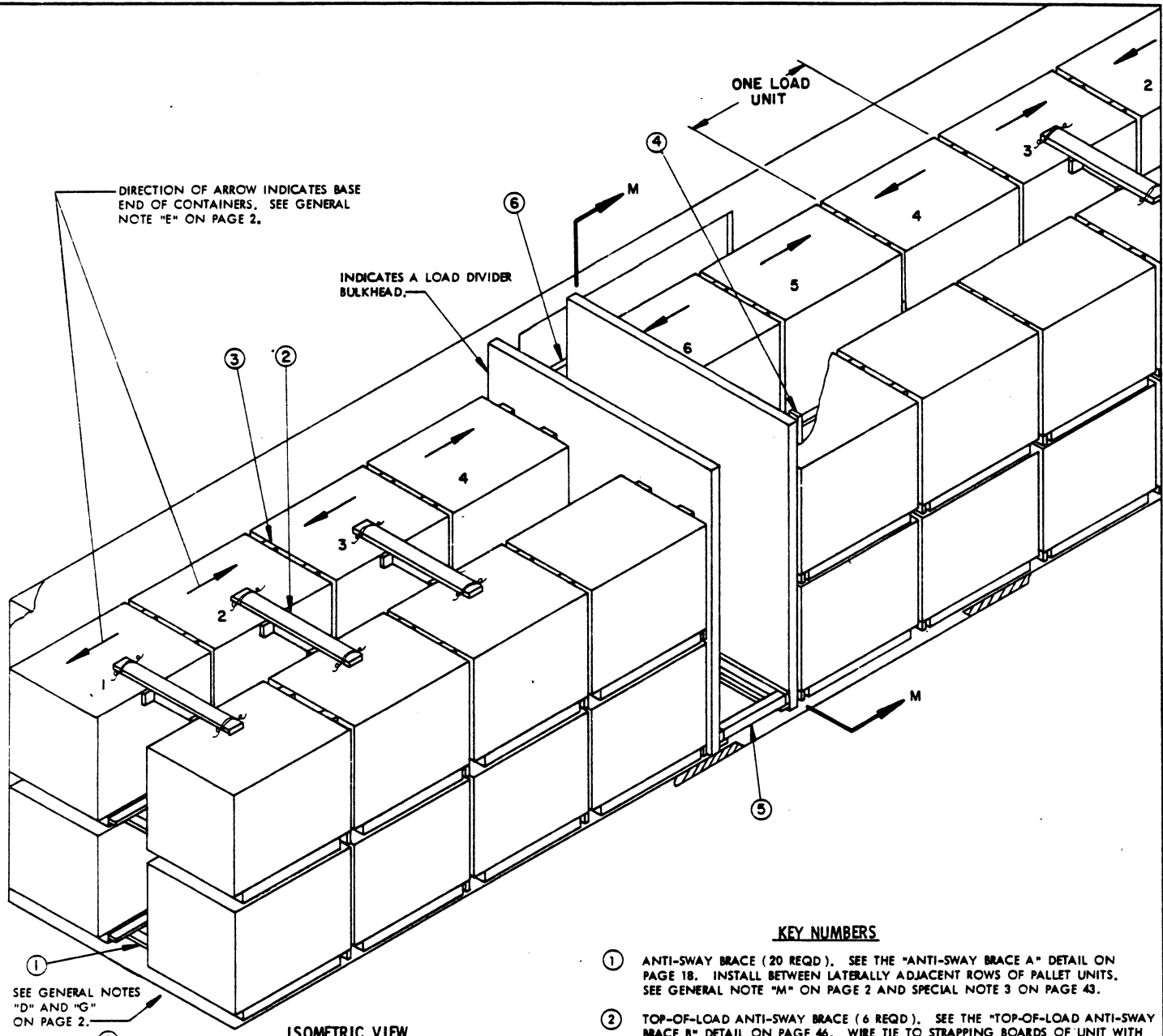

ISOMETRIC VIEW

SEE GENERAL NOTES "D" AND "G" ON PAGE 2.

**KEY NUMBERS**

- ① ANTI-SWAY BRACE (20 REQD). SEE THE "ANTI-SWAY BRACE A" DETAIL ON PAGE 18. INSTALL BETWEEN LATERALLY ADJACENT ROWS OF PALLET UNITS. SEE GENERAL NOTE "M" ON PAGE 2 AND SPECIAL NOTE 3 ON PAGE 43.
- ② TOP-OF-LOAD ANTI-SWAY BRACE (6 REQD). SEE THE "TOP-OF-LOAD ANTI-SWAY BRACE B" DETAIL ON PAGE 46. WIRE TIE TO STRAPPING BOARDS OF UNIT WITH NO. 14 GAGE WIRE AS TYPICALLY SHOWN BY THE "TIE WIRE APPLICATION B" DETAIL ON PAGE 122. SEE SPECIAL NOTE 4 ON PAGE 43.
- ③ SEPARATOR GATE (10 REQD). SEE THE "SEPARATOR GATE F" DETAIL ON PAGE 45. POSITION WITH THE HORIZONTAL PIECES AGAINST THE ALREADY-LOADED UNITS. SEE SPECIAL NOTES 5 AND 7 ON PAGE 43.
- ④ STOP PIECE, 1" X 4" X 57" (4 REQD). POSITION AGAINST PALLET UNITS IN THE DOORWAY AREA AND NAIL TO THE HORIZONTAL PIECES OF PIECE MARKED ③ W/3-6d NAILS AT EACH JOINT AND CLINCH. SEE SPECIAL NOTE 6 ON PAGE 43.
- ⑤ STRUT ASSEMBLY (1 REQD). SEE THE "STRUT ASSEMBLY FOR 1-PIECE BULKHEADS" DETAIL ON PAGE 129. INSTALL BETWEEN THE LOAD DIVIDER BULKHEADS. SEE SPECIAL NOTE 9 ON PAGE 43.
- ⑥ DOORWAY PROTECTION (2 REQD). SEE THE "DOORWAY PROTECTION D" DETAIL ON PAGE 46. NAIL TO THE DOOR POSTS W/12d NAILS. SEE SPECIAL NOTE 8 ON PAGE 43.

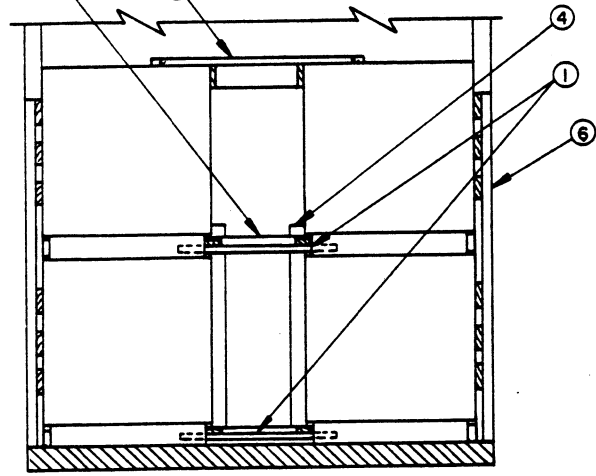

SECTION M-M

FLAT DUNNAGE METHOD UNIT ( BASIC HEIGHT )  
 40-UNIT LOAD IN A 50'-6" LONG BY 9'-2" WIDE BOX CAR EQUIPPED WITH LOAD DIVIDERS

( SPECIAL NOTES CONTINUED )

- 10. THE DEPICTED LOAD CAN BE REDUCED TO SUIT THE QUANTITY TO BE SHIPPED. A 2-TIER LOAD CAN BE REDUCED BY A MULTIPLE OF FOUR ( 4 ) PALLET UNITS OR A 1-TIER LOAD CAN BE REDUCED BY A MULTIPLE OF TWO ( 2 ) UNITS BY OMITTING ONE OR MORE LOAD UNITS FROM THE CENTER PORTION OF THE LOAD. OR, THE ENTIRE TOP TIER CAN BE OMITTED. FOR OTHER METHODS OF REDUCING A LOAD, AND FOR TYPICAL LCL PROCEDURES, REFER TO PAGES 94 THRU 105 AND GENERAL NOTE "FF" ON PAGE 3 FOR GUIDANCE.
- 11. IF PALLET UNITS WHICH DO NOT CONTAIN A FULL QUANTITY OF CONTAINERS ARE TO BE TRANSPORTED, REFER TO PAGE 117 AND/OR PAGES 118 AND 120 FOR SHIPPING GUIDANCE.
- 12. FOR SHIPMENT OF ONE OR MORE LEFTOVER CONTAINERS, SEE THE "PROCEDURES FOR SHIPMENT OF LEFTOVER CONTAINERS" ON PAGE 119 FOR GUIDANCE.

SPECIAL NOTES:

- 1. A 50'-6" LONG BY 9'-2" WIDE WOOD-LINED CUSHIONED BOX CAR EQUIPPED WITH LOAD DIVIDER BULKHEADS AND WITH 10'-0" WIDE DOOR OPENINGS IS SHOWN. CARS OF OTHER DIMENSIONS AND CARS HAVING NARROWER OR WIDER DOOR OPENINGS CAN BE USED. SEE GENERAL NOTES "AA" THRU "EE" ON PAGE 3.
- 2. THE PALLET UNIT SHOWN IN THE TYPICAL LOAD ON PAGE 42 IS THE FLAT DUNNAGE METHOD UNIT ( BASIC HEIGHT ). A MAXIMUM OF FORTY-EIGHT ( 48 ) OF THESE UNITS, FOR AN APPROXIMATE LADING WEIGHT OF 102,096 POUNDS, CAN BE PLACED IN A 60'-8" LONG CAR, OR A MAXIMUM OF THIRTY-TWO UNITS CAN BE PLACED IN A 40'-6" CAR FOR AN APPROXIMATE LADING WEIGHT OF 68,064 POUNDS, WHEN USING THE DEPICTED PROCEDURES. IF CARS 9'-4" OR WIDER ARE AVAILABLE, THE CROSSWISE LOADING PATTERN SHOWN ON PAGE 38 MAY BE EMPLOYED. THEN, SIXTY-FOUR ( 64 ) PALLET UNITS FOR AN APPROXIMATE LADING WEIGHT OF 136,128 POUNDS CAN BE PLACED IN A 60'-8" LONG CAR, FIFTY-TWO ( 52 ) UNITS CAN BE PLACED IN A 50'-6" LONG CAR FOR AN APPROXIMATE LADING WEIGHT OF 110,604 POUNDS, AND FORTY ( 40 ) UNITS CAN BE PLACED IN A 40'-6" LONG CAR FOR AN APPROXIMATE LADING WEIGHT OF 85,080 POUNDS.
- 3. IF THE "ALTERNATIVE DOORWAY PROTECTION F" PROCEDURES AS SHOWN ON PAGE 128 ARE USED IN LIEU OF THE WOODEN DOOR GATE TYPE PROTECTION, PIECE MARKED ⑤, NAILED FLOORLINE BLOCKING MUST BE USED IN LIEU OF THE LOWER ANTI-SWAY BRACE IN THE DOORWAY AREA. NAILED BLOCKING IS REQUIRED FOR ALL PALLET STACKS WHICH ARE COMPLETELY WITHIN THE DOORWAY AREA OR WHICH EXTEND INTO THE DOORWAY AREA BY ONE-HALF OR MORE OF THE STACK WIDTH ON EITHER SIDE OF THE CAR.
- 4. TOP-OF-LOAD ANTI-SWAY BRACES, SHOWN AS PIECES MARKED ② IN THE LOAD ON PAGE 42, MUST BE INSTALLED IN EACH END OF THE CAR AND WIRE TIED TO STRAPPING BOARDS WITH NO. 14 GAGE WIRE AS TYPICALLY SHOWN BY THE "TIE WIRE APPLICATION B" DETAIL ON PAGE 122. THREE ( 3 ) BRACES ARE REQUIRED IN EACH END OF A LOAD REGARDLESS OF THE CAR LENGTH.
- 5. TO FACILITATE POSITIONING OF THE PALLET UNITS AS LOADING PROGRESSES, POSITION PALLET UNIT STACKS AGAINST THE END WALL, THEN POSITION A SEPARATOR GATE SHOWN AS PIECE MARKED ③, SO THE 1" X 4" TIE PIECES ARE LOCATED UNDER THE "OVERHANG" OF THE PALLET UNITS. REPEAT THIS PROCEDURE FOR THE REMAINING STACKS.
- 6. SEPARATOR GATES IN THE DOORWAY MUST BE PREVENTED FROM SHIFTING INTO A DOOR OPENING BY THE APPLICATION OF THE STOP PIECES, PIECES MARKED ④ IN CARS EQUIPPED WITH STAGGERED DOORS, STOP PIECES MAY BE REQUIRED ON UP TO FOUR SEPARATOR GATES.
- 7. SEPARATOR GATES MAY BE FORMED FROM 3/8" OR THICKER PLYWOOD IN LIEU OF DIMENSIONAL LUMBER, IF DESIRED. SEE THE "ALTERNATIVE SEPARATOR GATE" DETAIL ON PAGE 122 FOR CONSTRUCTION GUIDANCE.
- 8. DOORWAY PROTECTION IS REQUIRED FOR ALL PALLET UNIT STACKS WHICH ARE COMPLETELY WITHIN THE DOORWAY AREA OR WHICH EXTEND INTO THE DOORWAY AREA BY ONE-HALF OR MORE OF THE STACK WIDTH. THE WOODEN GATE TYPE OF DOORWAY PROTECTION, SHOWN AS PIECES MARKED ⑥ IN THE LOAD ON PAGE 42, IS APPLICABLE FOR BOX CARS EQUIPPED WITH CONVENTIONAL SLIDING DOORS AND NAILABLE DOOR POSTS. REFER TO PAGES 126 THRU 128 FOR ALTERNATIVE DOORWAY PROTECTION FOR CARS EQUIPPED WITH CONVENTIONAL SLIDING DOORS. IF THE CAR BEING LOADED IS EQUIPPED WITH PLUG TYPE DOORS, NAILED FLOORLINE BLOCKING AND LOAD BUNDLING STRAPS MUST BE USED. SEE THE "ALTERNATIVE DOORWAY PROTECTION F" DETAIL ON PAGE 128 FOR GUIDANCE IF THE PALLET UNITS ARE POSITIONED AS SHOWN ON PAGE 42. SEE THE "ALTERNATIVE DOORWAY PROTECTION E" DETAIL ON THAT PAGE IF THE PALLET UNITS ARE POSITIONED CROSSWISE.
- 9. THE STRUT ASSEMBLY, SHOWN AS PIECE MARKED ⑤ IN THE LOAD ON PAGE 42, IS REQUIRED WHEN THE LOAD IN EITHER END OF A CAR IS 50,000 POUNDS OR MORE. FOR THE DEPICTED LOAD THE STRUT ASSEMBLY WOULD NOT BE REQUIRED IF THE LOAD CONSISTED OF FIVE ( 5 ) LOAD UNITS IN EACH END OF THE CAR. THE STRUT ASSEMBLY WILL ALWAYS BE REQUIRED FOR FULL LOADS IN 60' OR LONGER CARS.

( CONTINUED AT LEFT )

BILL OF MATERIAL		
LUMBER	LINEAR FEET	BOARD FEET
1" X 4"	202	68
1" X 6"	410	205
1" X 8"	18	12
2" X 3"	32	16
2" X 4"	323	216
2" X 6"	19	19
4" X 4"	10	14
NAILS	NO. REQD	POUNDS
6d ( 2" )	330	2
10d ( 3" )	358	5-1/2
12d ( 3-1/4" )	32	3/4
WIRE, NO. 14 GAGE----- 60' REQD-----1 LB		

LOAD AS SHOWN

ITEM	QUANTITY	WEIGHT ( APPROX )
PALLET UNIT -----	40 -----	85,080 LBS
DUNNAGE -----		1,109 LBS
TOTAL WEIGHT -----		86,189 LBS

FLAT DUNNAGE METHOD UNIT ( BASIC HEIGHT )  
40-UNIT LOAD IN A 50'-6" LONG BY 9'-2" WIDE BOX CAR EQUIPPED WITH LOAD DIVIDERS

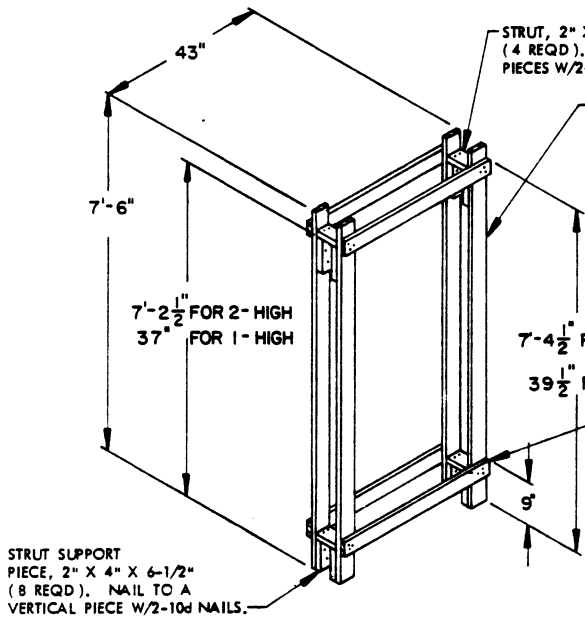

STRUT SUPPORT  
PIECE, 2" X 4" X 6-1/2"  
(8 REQD.). NAIL TO A  
VERTICAL PIECE W/2-10d  
NAILS.

STRUT, 2" X 4" BY A LENGTH TO SUIT  
(4 REQD.). NAIL TO THE STRUT SUPPORT  
PIECES W/2-10d NAILS AT EACH END.

VERTICAL PIECE, 2" X 4" X 7'-6"  
FOR A 2-HIGH LOAD, 42" FOR A  
1-HIGH LOAD (4 REQD.).

7'-4 1/2" FOR 2-HIGH  
39 1/2" FOR 1-HIGH

HORIZONTAL PIECE, 2" X 4"  
X 43" (4 REQD.). NAIL TO  
THE VERTICAL PIECES W/3-10d  
NAILS AT EACH END.

STRUT SUPPORT PIECE,  
2" X 4" X 6-1/2"  
(8 REQD.). NAIL TO  
A VERTICAL PIECE  
W/2-10d NAILS.

**CRIB FILL E**

CRIB FILL ASSEMBLIES "E" AND "F" SHOULD BE  
PRE-FABRICATED. CONSTRUCT TO BE 1/2" TO 3/4"  
LESS IN WIDTH THAN THE DISTANCE BETWEEN  
LATERALLY ADJACENT ROWS OF PALLET UNITS.

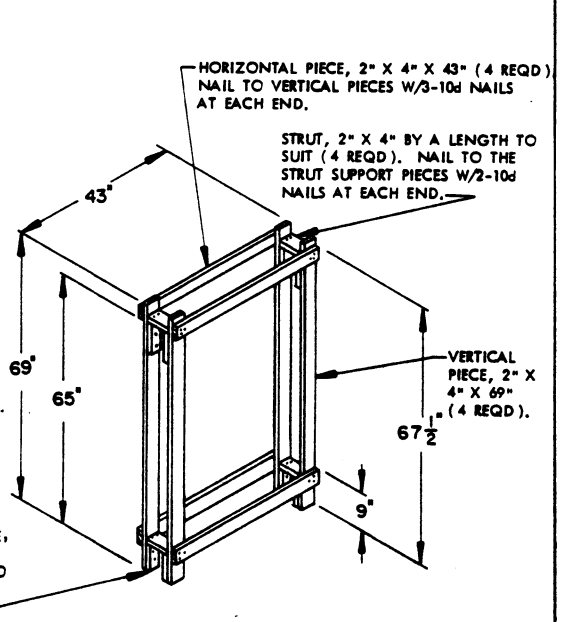

HORIZONTAL PIECE, 2" X 4" X 43" (4 REQD.)  
NAIL TO VERTICAL PIECES W/3-10d NAILS  
AT EACH END.

STRUT, 2" X 4" BY A LENGTH TO  
SUIT (4 REQD.). NAIL TO THE  
STRUT SUPPORT PIECES W/2-10d  
NAILS AT EACH END.

VERTICAL  
PIECE, 2" X  
4" X 69"  
(4 REQD.).

**CRIB FILL F**

CRIB FILL "F" IS NOT REQUIRED FOR A 1-HIGH LOAD;  
USE CRIB FILL "E" THROUGHOUT THE LENGTH OF THE LOAD.

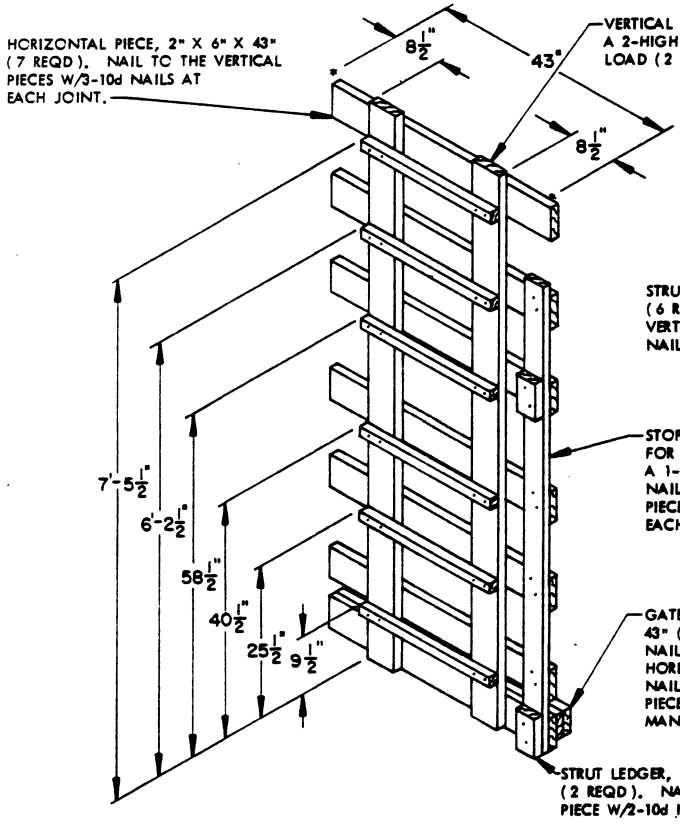

HORIZONTAL PIECE, 2" X 6" X 43"  
(7 REQD.). NAIL TO THE VERTICAL  
PIECES W/3-10d NAILS AT  
EACH JOINT.

VERTICAL PIECE, 2" X 6" X 8'-3" FOR  
A 2-HIGH LOAD, 50" FOR A 1-HIGH  
LOAD (2 REQD.).

STRUT LEDGER, 2" X 2" X 26"  
(6 REQD.). NAIL TO THE  
VERTICAL PIECES W/2-10d  
NAILS AT EACH END.

STOP PIECE, 2" X 4" X 6'-9"  
FOR A 2-HIGH LOAD, 48" FOR  
A 1-HIGH LOAD (1 REQD.).  
NAIL TO THE HORIZONTAL  
PIECES W/2-10d NAILS AT  
EACH JOINT.

GATE HOLD DOWN, 2" X 4" X  
43" (DOUBLED) (1 REQD.).  
NAIL FIRST PIECE TO THE BOTTOM  
HORIZONTAL PIECE W/5-10d  
NAILS. LAMINATE THE SECOND  
PIECE TO THE FIRST IN A LIKE  
MANNER.

STRUT LEDGER, 2" X 4" X 6-1/2"  
(2 REQD.). NAIL TO THE  
STOP  
PIECE W/2-10d NAILS.

**CENTER GATE J**

1 RIGHT HAND AND 1 LEFT HAND GATE REQUIRED.

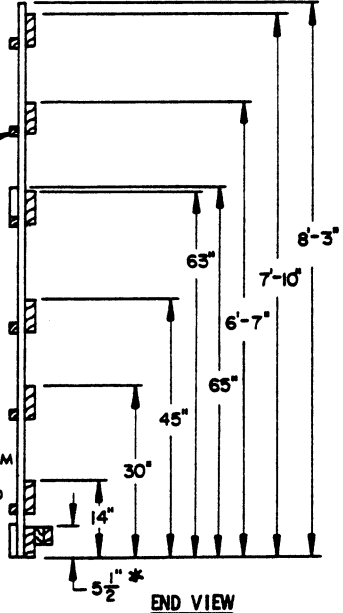

\* THE DIMENSION SHOWN IS FOR A GATE WHICH IS TO BE  
POSITIONED AGAINST THE BELL ENDS OF THE CONTAINERS. THIS  
DIMENSION WILL BE 6-1/2" FOR THE BASE END OF THE UNIT.

**DETAILS FOR FLAT DUNNAGE METHOD (BASIC HEIGHT)**

HORIZONTAL PIECE, 1" X 4" X 43" (2 REQD).  
NAIL TO THE VERTICAL PIECES AND THE STOP  
PIECE W/3-6d NAILS AT EACH JOINT  
AND CLINCH.

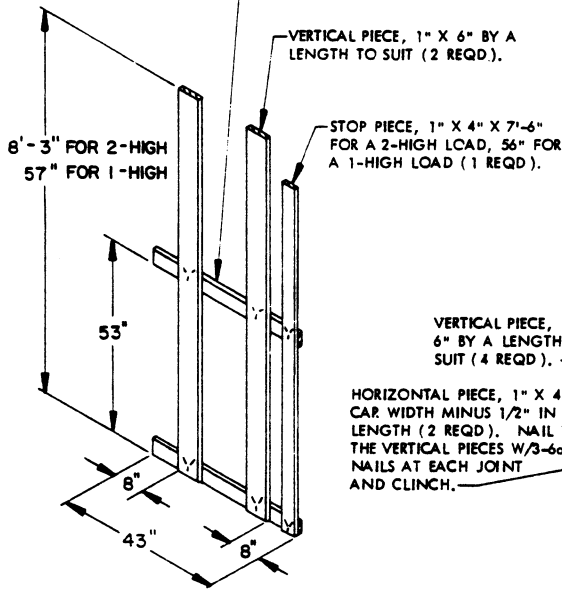

VERTICAL PIECE, 1" X 6" BY A  
LENGTH TO SUIT (2 REQD).

STOP PIECE, 1" X 4" X 7'-6"  
FOR A 2-HIGH LOAD, 56" FOR  
A 1-HIGH LOAD (1 REQD).

HORIZONTAL PIECE, 1" X 4" BY  
CAR WIDTH MINUS 1/2" IN  
LENGTH (2 REQD). NAIL TO  
THE VERTICAL PIECES W/3-6d  
NAILS AT EACH JOINT  
AND CLINCH.

VERTICAL PIECE, 1" X  
6" BY A LENGTH TO  
SUIT (4 REQD).

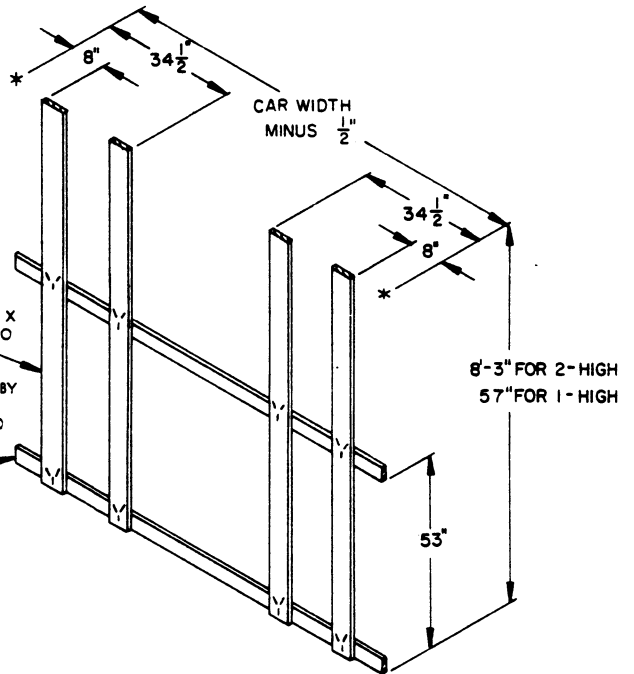

**SEPARATOR GATE E**

RIGHT HAND AND LEFT HAND GATES ARE REQUIRED. A RIGHT  
HAND GATE IS SHOWN.

**SEPARATOR GATE F**

HORIZONTAL PIECE, 2" X 6" X 55"  
(8 REQD). NAIL TO THE VERTICAL  
PIECES W/3-10d NAILS AT EACH  
JOINT.

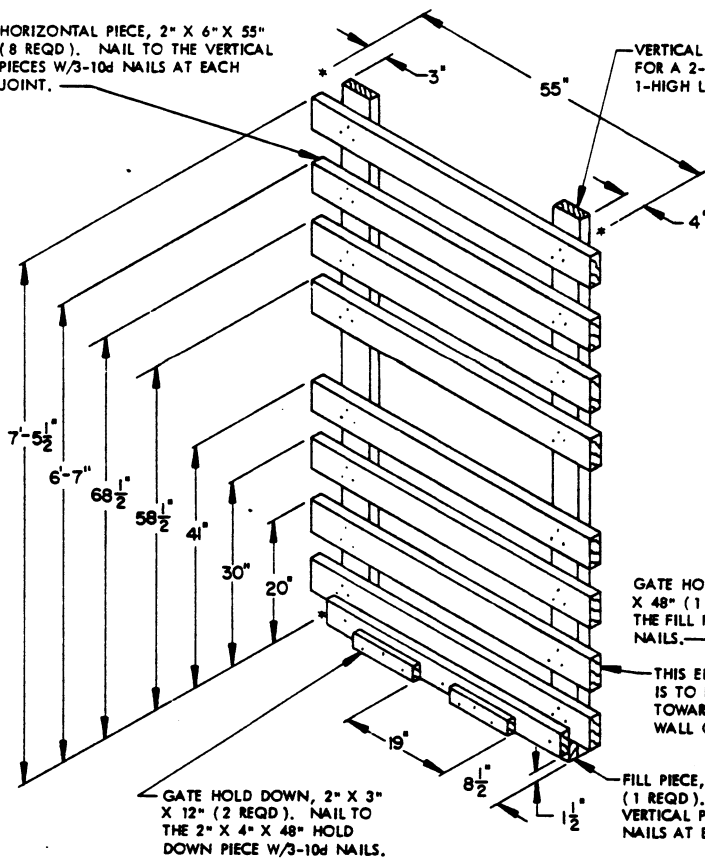

VERTICAL PIECE, 2" X 6" X 7'-10"  
FOR A 2-HIGH LOAD, 46" FOR A  
1-HIGH LOAD (2 REQD).

GATE HOLD DOWN, 2" X 4"  
X 48" (1 REQD). NAIL TO  
THE FILL PIECE W/3-10d  
NAILS.

THIS EDGE OF THE GATE  
IS TO BE POSITIONED  
TOWARD THE SIDE-  
WALL OF CAR.

FILL PIECE, 2" X 4" X 48"  
(1 REQD). NAIL TO THE  
VERTICAL PIECES W/3-10d  
NAILS AT EACH END.

GATE HOLD DOWN, 2" X 3"  
X 12" (2 REQD). NAIL TO  
THE 2" X 4" X 48" HOLD  
DOWN PIECE W/3-10d NAILS.

**CENTER GATE K**

1 RIGHT HAND AND 1 LEFT HAND GATE REQUIRED.

STRUT LEDGER, 2" X 2" X 48" (8 REQD).  
NAIL TO THE VERTICAL PIECES W/2-10d  
NAILS AT EACH END.

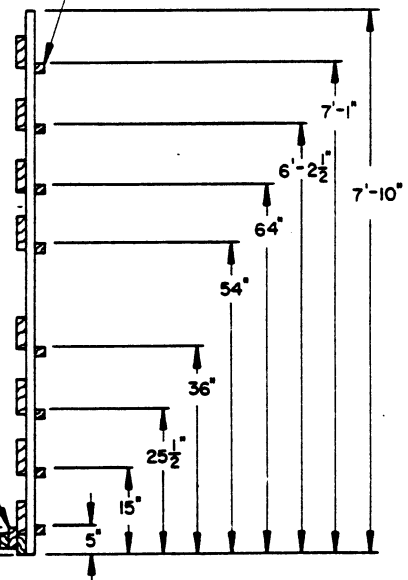

**END VIEW**

NOTE THAT THE UPPER THREE STRUT LEDGERS FOR EACH TIER  
ON ONE CENTER GATE MAY NEED TO BE APPLIED AFTER THE  
NEXT LOWER LEVEL STRUTS HAVE BEEN INSTALLED.

SUPPORT PIECE, 2" X 4" BY A LENGTH TO SUIT (1 REQD). NAIL TO SPACER PIECE W/4-10d NAILS AND TO THE BUFFER PIECES W/2-10d NAILS AT EACH JOINT.

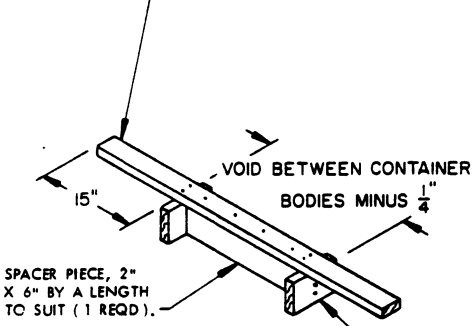

**TOP-OF-LOAD ANTI-SWAY BRACE B**

HORIZONTAL PIECE, 1" X 6" BY DOOR OPENING WIDTH (4 REQD). NAIL TO THE VERTICAL PIECES W/3-6d NAILS AT EACH END.

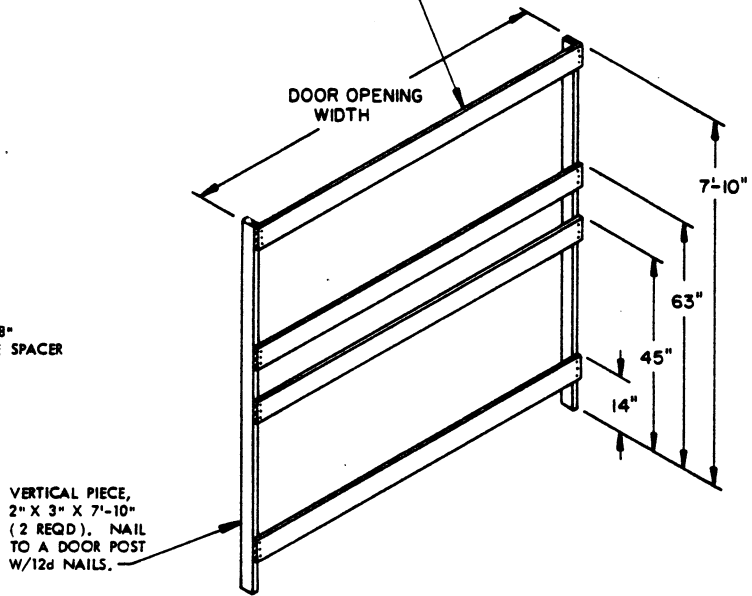

**DOORWAY PROTECTION D**

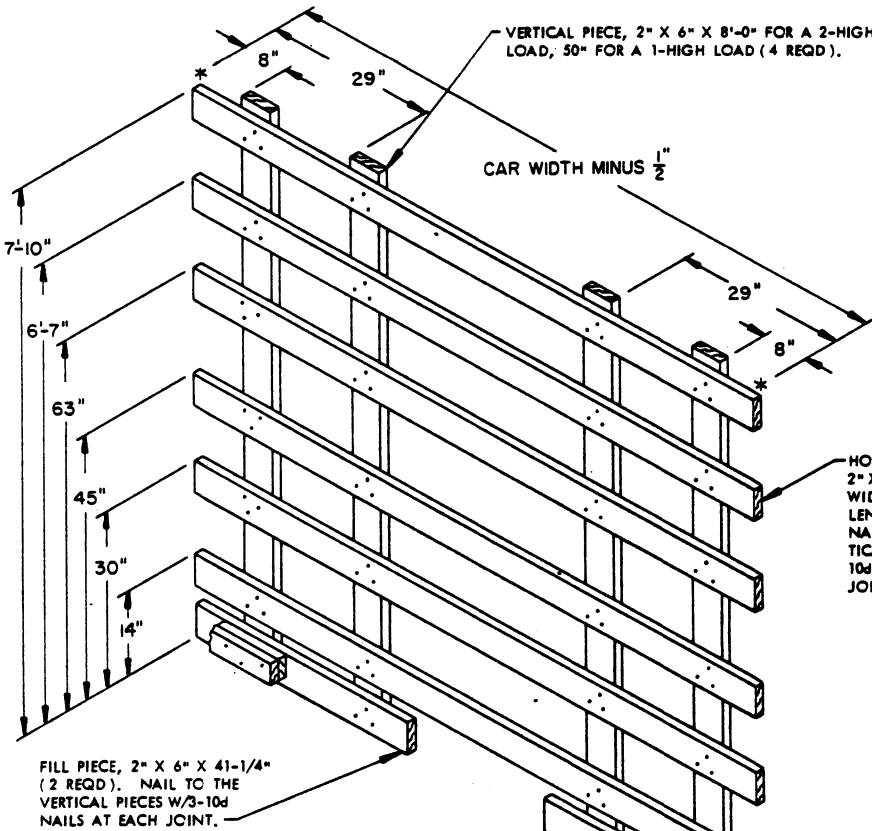

GATE HOLD DOWN, 2" X 4" X 18" (DOUBLED) (2 REQD). NAIL THE FIRST PIECE TO A FILL PIECE W/3-10d NAILS. LAMINATE THE SECOND PIECE TO THE FIRST IN A LIKE MANNER. SEE SPECIAL NOTE 11 ON PAGE 37.

**CENTER GATE L**

STRUT LEDGER, 2" X 2" BY CAR WIDTH MINUS 16- $\frac{1}{2}$ " IN LENGTH (6 REQD). NAIL TO THE VERTICAL PIECES W/2-10d NAILS AT EACH JOINT.

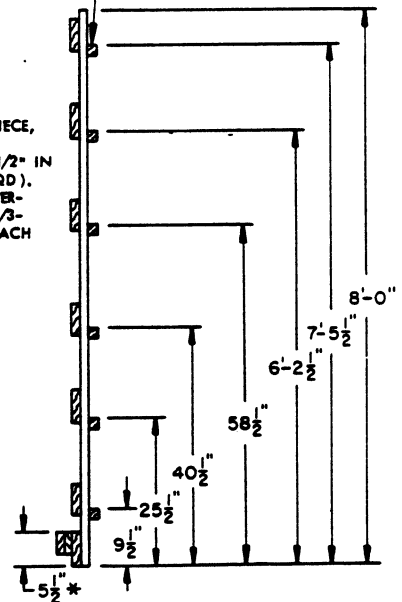

**END VIEW**

\*THE DIMENSION SHOWN IS FOR A GATE WHICH IS TO BE POSITIONED AGAINST THE BELL END OF THE CONTAINER. THIS DIMENSION WILL BE 6- $\frac{1}{2}$ " FOR THE BASE END OF UNITS.

**DETAILS FOR FLAT DUNNAGE METHOD UNIT ( BASIC HEIGHT )**

VERTICAL PIECE, 2" X 3" X 7'-6" FOR A 2-HIGH LOAD, 41" FOR A 1-HIGH LOAD (2 REQD.). NAIL TO A DOOR POST W/12d NAILS.

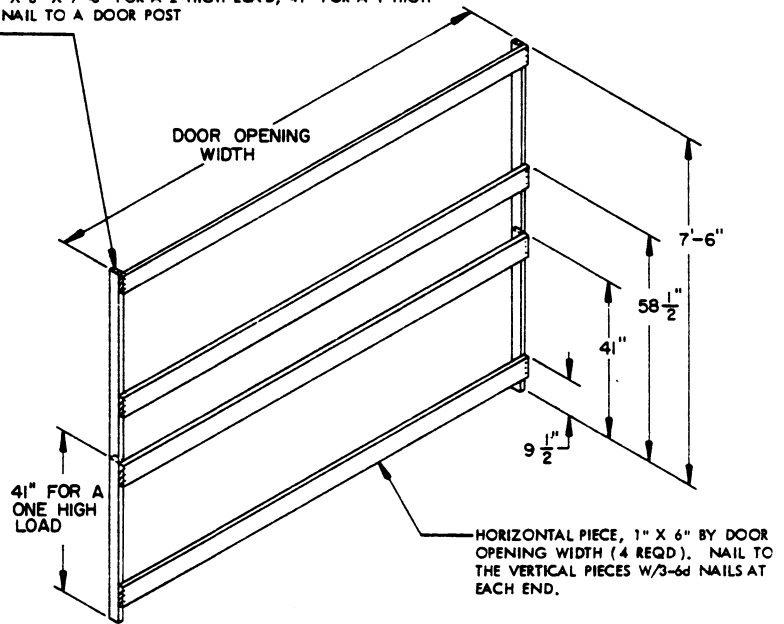

**DOORWAY PROTECTION E**

VERTICAL PIECE, 2" X 6" X 8'-0" FOR A 2-HIGH LOAD, 46" FOR A 1-HIGH LOAD (4 REQD).

HORIZONTAL PIECE, 2" X 6" BY CAR WIDTH MINUS 5-1/2" IN LENGTH (2 REQD). NAIL TO THE VERTICAL PIECES W/3-10d NAILS AT EACH JOINT.

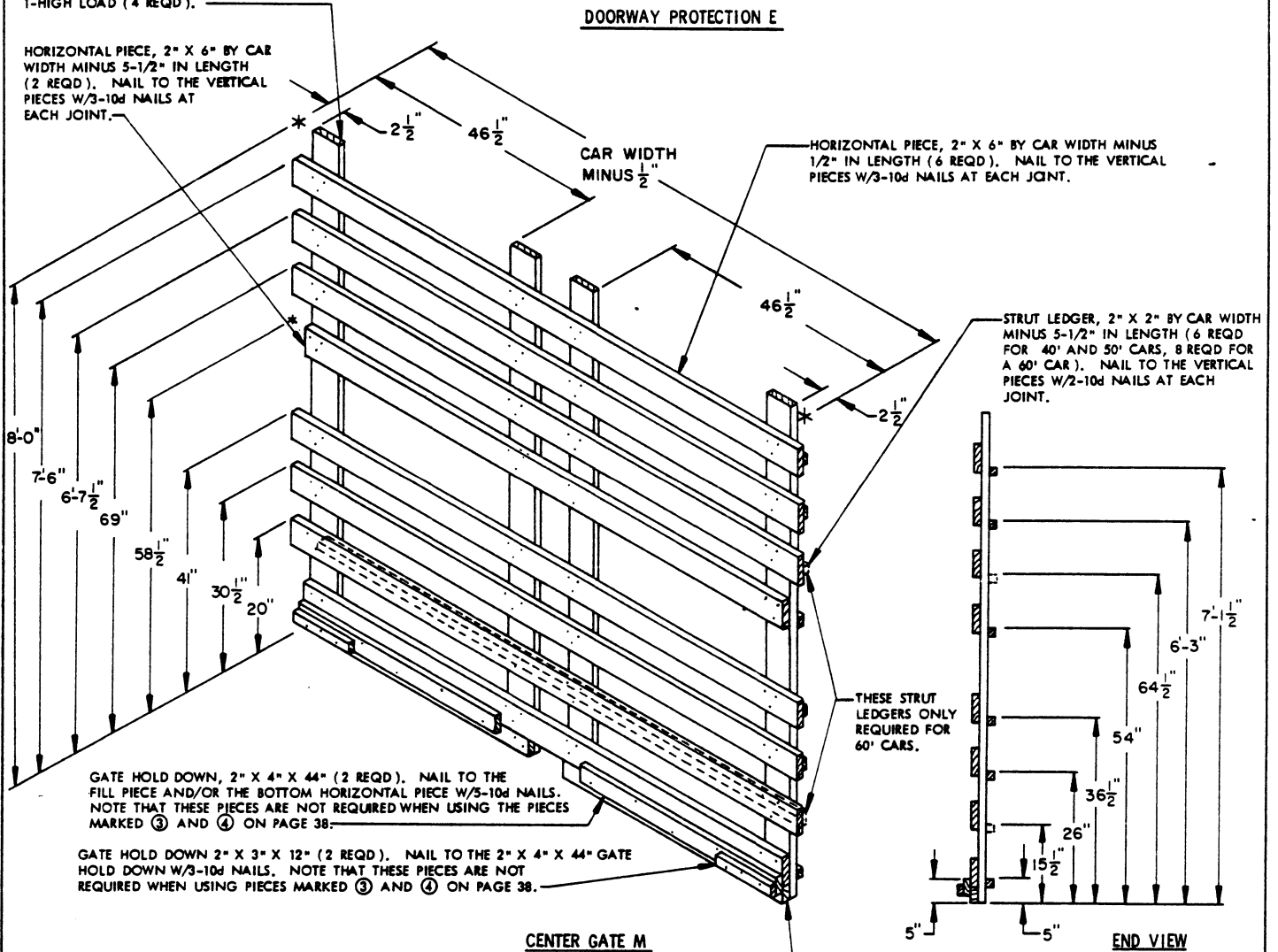

**CENTER GATE M**

**END VIEW**

FILL PIECE, 2" X 4" X 49-1/2" (2 REQD). NAIL TO THE VERTICAL PIECES W/3-10d NAILS AT EACH END. THESE PIECES ARE NOT REQUIRED WHEN USING PIECES MARKED ③ AND ④ ON PAGE 38.

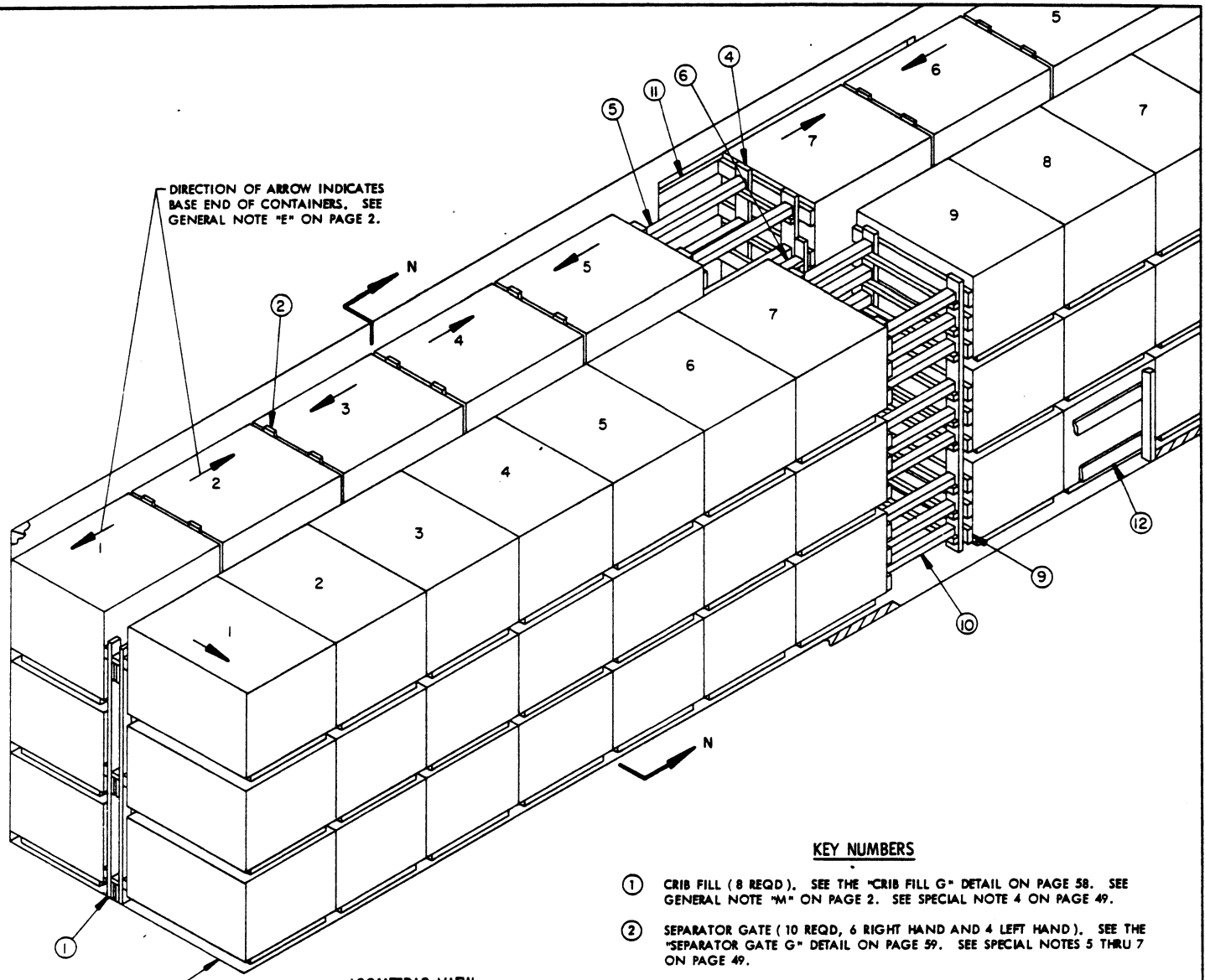

DIRECTION OF ARROW INDICATES  
BASE END OF CONTAINERS. SEE  
GENERAL NOTE "E" ON PAGE 2.

SEE GENERAL NOTES  
"D" AND "G"  
ON PAGE 2.

**ISOMETRIC VIEW**

**KEY NUMBERS**

- ① CRIB FILL (8 REQD). SEE THE "CRIB FILL G" DETAIL ON PAGE 58. SEE GENERAL NOTE "M" ON PAGE 2. SEE SPECIAL NOTE 4 ON PAGE 49.
- ② SEPARATOR GATE (10 REQD, 6 RIGHT HAND AND 4 LEFT HAND). SEE THE "SEPARATOR GATE G" DETAIL ON PAGE 59. SEE SPECIAL NOTES 5 THRU 7 ON PAGE 49.
- ③ CRIB FILL (8 REQD). SEE THE "CRIB FILL H" DETAIL ON PAGE 58.
- ④ CENTER GATE (2 REQD, 1 RIGHT HAND AND 1 LEFT HAND). SEE THE "CENTER GATE N" DETAIL ON PAGE 58. SEE SPECIAL NOTE 8 ON PAGE 49.
- ⑤ STRUT, 4" X 4" BY CUT TO FIT (REF: 48") (12 REQD). TOENAIL TO PIECES MARKED ④ W/2-16d NAILS AT EACH END. SEE GENERAL NOTES "L", "5", AND "T" ON PAGE 2.
- ⑥ STRUT, 2" X 4" BY CUT TO FIT (REF: 48") (3 REQD). TOENAIL TO THE STOP PIECES OF PIECES MARKED ④ W/2-12d NAILS AT EACH END.
- ⑦ SIDE BLOCKING FOR CENTER GATE "N", 2" X 4" X 18" (DOUBLED) (1 REQD). NAIL THE FIRST PIECE TO THE CAR FLOOR W/4-16d NAILS. NAIL THE SECOND PIECE TO THE FIRST IN A LIKE MANNER. SEE THE "PARTIAL PLAN VIEW" ON PAGE 49.
- ⑧ CRIB FILL RETAINER, 2" X 4" BY A LENGTH TO SUIT (REF: 54") (2 REQD). POSITION TO SPAN THE STRUTS OF LONGITUDINALLY ADJACENT CRIB FILL "H" ASSEMBLIES AT THE CENTER OF THE CAR AND NAIL TO EACH STRUT W/3-10d NAILS. SEE THE "PARTIAL PLAN VIEW" ON PAGE 49.
- ⑨ CENTER GATE (2 REQD). SEE THE "CENTER GATE O" DETAIL ON PAGE 59.
- ⑩ STRUT, 4" X 4" BY CUT TO FIT (REF: 34") (18 REQD). TOENAIL TO PIECES MARKED ⑨ W/2-16d NAILS AT EACH END.
- ⑪ DOORWAY PROTECTION (1 REQD). SEE THE "DOORWAY PROTECTION F" DETAIL ON PAGE 60. NAIL TO THE DOOR POSTS W/12d NAILS. SEE SPECIAL NOTE 9 ON PAGE 49.
- ⑫ DOORWAY PROTECTION (1 REQD). SEE THE "DOORWAY PROTECTION G" DETAIL ON PAGE 61. NAIL TO THE DOOR POSTS W/12d NAILS.

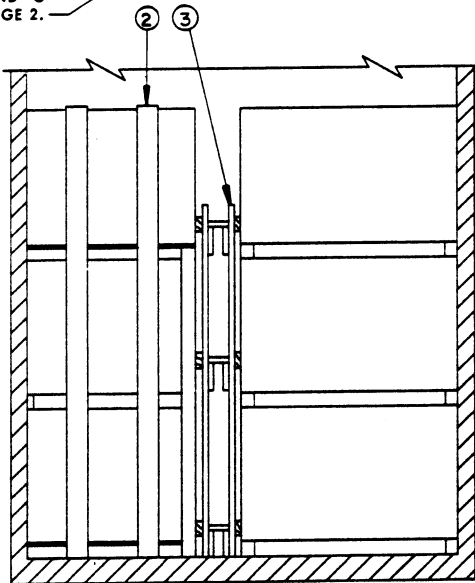

**SECTION N-N**

FLAT DUNNAGE METHOD UNIT (DECREASED HEIGHT)  
84-UNIT LOAD IN A 60'-8" LONG BY 9'-2" WIDE CONVENTIONAL BOX CAR



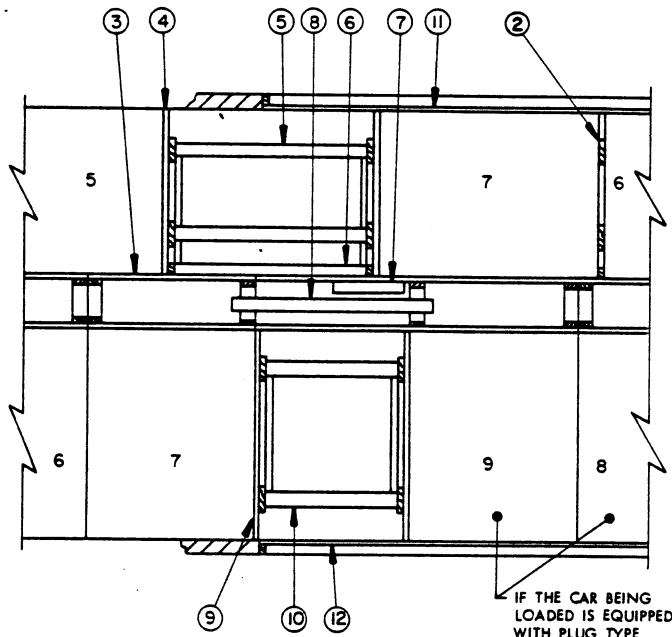

**PARTIAL PLAN VIEW**

IF THE CAR BEING LOADED IS EQUIPPED WITH PLUG TYPE DOORS, SEE SPECIAL NOTE 9 AT RIGHT.

(SPECIAL NOTES CONTINUED)

PIECES AND BOTTOM SUPPORT PIECES OF THE CRIB FILL, PIECES MARKED ③, MUST HAVE THREE INCHES (3") CUT OFF THE BOTTOM END OF ONE SIDE SO THE CRIB WILL REST EVENLY ON THE NAILED SIDE BLOCKING WHICH IS ADJACENT TO THE LENGTHWISE UNITS. ALSO NOTE THAT THE SIDE BLOCKING FOR THE CROSSWISE UNITS MUST BE PRE-POSITIONED APPROXIMATELY FIFTY-TWO INCHES (52") FROM THE NEAR SIDE CAR WALL, AND THE CENTER GATE "N" WHICH IS IN THE DOORWAY MUST BE WIRE TIED TO PIECE MARKED ⑨ TO PREVENT DISPLACEMENT.

10. THE DEPICTED LOAD CAN BE REDUCED TO SUIT THE QUANTITY TO BE SHIPPED. THE LOAD CAN BE REDUCED BY ONE OR MORE PALLET UNITS BY EMPLOYING THE PROCEDURES SHOWN ON PAGE 96. SIX (6) PALLET UNITS CAN BE OMITTED FROM A 3-TIER LOAD BY LEAVING OUT THE LENGTHWISE STACK NUMBERED 7, THE CROSSWISE STACK NUMBERED 9 AND THE ADJACENT CRIB FILL. NOTE THAT STRUT BRACING MUST BE APPLIED TO ALL THE STRUTS. OR, THE ENTIRE ONE OR TWO TOP TIERS CAN BE OMITTED. A PARTIAL 1-TIER LOAD CAN BE SHIPPED IN ONE OR BOTH ENDS OF A CAR BY USING KNEE BRACES AS SHOWN ON PAGES 112 AND 113.
11. IF PALLETIZED UNITS WHICH DO NOT CONTAIN A FULL QUANTITY OF CONTAINERS ARE TO BE TRANSPORTED, REFER TO PAGE 117 FOR SHIPPING GUIDANCE FOR LENGTHWISE UNITS AND PAGES 118 AND 120 FOR CROSSWISE UNITS.
12. FOR SHIPMENT OF ONE OR MORE LEFTOVER CONTAINERS, SEE THE "PROCEDURES FOR SHIPMENT OF LEFTOVER CONTAINERS" ON PAGE 119 FOR GUIDANCE.

**BILL OF MATERIAL**

LUMBER	LINEAR FEET	BOARD FEET
1" X 4"	142	48
1" X 6"	314	157
2" X 2"	98	33
2" X 3"	36	18
2" X 4"	1075	717
2" X 6"	206	206
4" X 4"	73	98
NAILS	NO. REQD	POUNDS
6d (2")	252	1-1/2
10d (3")	1704	26-1/4
12d (3-1/4")	48	1
16d (3-1/2")	128	3
WIRE, NO. 14 GAGE	3' REQD	NIL

**SPECIAL NOTES:**

1. A 60'-8" LONG BY 9'-2" WIDE WOOD-LINED CONVENTIONAL TYPE BOX CAR EQUIPPED WITH 10'-0" WIDE DOOR OPENINGS IS SHOWN. CARS OF OTHER DIMENSIONS AND CARS HAVING WIDER OR NARROWER DOOR OPENINGS CAN BE USED. SEE GENERAL NOTE "D" ON PAGE 2 AND SPECIAL NOTE 3 BELOW.
2. THE PALLET UNIT SHOWN IN THE TYPICAL LOAD ON PAGE 48 IS THE FLAT DUNNAGE METHOD UNIT (DECREASED HEIGHT). A MAXIMUM OF SIXTY-NINE (69) OF THESE UNITS, FOR AN APPROXIMATE LADING WEIGHT OF 111,366 POUNDS, CAN BE PLACED IN A 50'-6" LONG CAR WHEN USING THE DEPICTED PROCEDURES; FIFTY-FOUR (54) UNITS, FOR A LADING WEIGHT OF 87,156 POUNDS, CAN BE OUTLOADED IN A 40'-6" LONG CAR.
3. THE DEPICTED LOADING PATTERN IS ADEQUATE FOR CARS HAVING DOOR OPENINGS AS NARROW AS 8'-0". IF A CAR HAVING DOOR OPENINGS LESS THAN 8'-0" WIDE IS TO BE LOADED, THE LENGTHWISE UNITS SHOULD BE LOADED SIX (6) STACKS LONG IN EACH END OF THE CAR AND THE CROSSWISE UNITS SHOULD BE LOADED EIGHT (8) STACKS LONG IN EACH END. PIECE MARKED ⑦ WILL NOT BE REQUIRED; THE BALANCE OF THE DUNNAGE WILL NOT CHANGE.
4. THE "HIGH" CRIB, SHOWN AS PIECE MARKED ①, MUST BE INSTALLED IN EACH END OF THE LOAD. FOUR (4) ASSEMBLIES ARE REQUIRED IN EACH END OF A LOAD REGARDLESS OF THE CAR LENGTH.
5. THE SEPARATOR GATES, SHOWN AS PIECES MARKED ② IN THE LOAD ON PAGE 48, ARE DESIGNATED "RIGHT HAND" AND "LEFT HAND" TO FACILITATE POSITIONING OF THE PALLET UNITS AS LOADING PROGRESSES. WHEN LOADING THE CAR, POSITION A PALLET UNIT STACK AGAINST THE END WALL, THEN POSITION A SEPARATOR GATE SO THE 1" X 4" TIE PIECES ARE LOCATED UNDER THE "OVERHANG" OF THE BOTTOM AND TOP PALLET UNITS. REPEAT THIS PROCEDURE FOR THE REMAINING STACKS.
6. ALL SEPARATOR GATES, PIECES MARKED ②, WHICH ARE WITHIN THE DOORWAY AREA OF A CAR EQUIPPED WITH CONVENTIONAL SLIDING DOORS MUST BE WIRE TIED TO THE ADJACENT CRIB FILL TO PREVENT DISPLACEMENT. ENCIRCLE THE STOP PIECE OF THE SEPARATOR GATE AND THE UPPER HORIZONTAL PIECE OF THE CRIB FILL WITH NO. 14 GAGE WIRE AND TWIST TAUT.
7. SEPARATOR GATES MAY BE FORMED FROM 3/8" OR THICKER PLYWOOD IN LIEU OF DIMENSIONAL LUMBER, IF DESIRED, FOR ONE OR TWO-LAYER LOADS; PLYWOOD SEPARATOR GATES FOR A 3-LAYER LOAD ARE NOT ECONOMICALLY FEASIBLE. CONSTRUCT EACH SEPARATOR GATE FOR ONE OR TWO-LAYER LOADS FROM 43" WIDE PLYWOOD OF AN APPROPRIATE LENGTH.
8. CENTER GATES "N" AND "C" MAY BE PARTIALLY FORMED FROM 1/2" OR THICKER PLYWOOD, IF DESIRED. PLYWOOD MAY BE USED IN LIEU OF THE 2" X 6" HORIZONTAL PIECES. SEE THE "PLYWOOD CENTER GATE ALTERNATIVE" DETAIL ON PAGE 123 FOR GUIDANCE.
9. DOORWAY PROTECTION IS REQUIRED FOR ALL PALLET UNIT STACKS WHICH ARE COMPLETELY WITHIN THE DOORWAY AREA OR WHICH EXTEND INTO THE DOORWAY AREA BY ONE-HALF OR MORE OF THE STACK WIDTH OR LENGTH. THE WOODEN GATE TYPE OF DOORWAY PROTECTION, SHOWN AS PIECES MARKED ⑪ AND ⑫ IN THE LOAD ON PAGE 48, IS APPLICABLE FOR BOX CARS EQUIPPED WITH CONVENTIONAL SLIDING DOORS AND NAILED DOOR POSTS. REFER TO PAGES 126 THRU 128 FOR ALTERNATIVE DOORWAY PROTECTION FOR CARS EQUIPPED WITH CONVENTIONAL SLIDING DOORS. IF THE CAR BEING LOADED IS EQUIPPED WITH PLUG TYPE DOORS, NAILED FLOORLINE BLOCKING AND LOAD-BUNDLING STRAPS MUST BE USED. SEE THE "ALTERNATIVE DOORWAY PROTECTION E" AND "ALTERNATIVE DOORWAY PROTECTION F" DETAILS ON PAGE 128 FOR GUIDANCE; A COMBINATION OF THE TWO METHODS MUST BE USED. NAILED SIDE BLOCKING, DOUBLED 2" X 4" X 7'-6" LONG, WILL BE USED UNDER THE CRIB FILL SHOWN IN THE DOORWAY AREA OF THE LOAD. POSITION ONE SIDE BLOCKING ADJACENT TO THE CROSSWISE STACKS NUMBERED 8 AND 9 AND ONE DIRECTLY OPPOSITE AGAINST ALL OR A PORTION OF THE LENGTHWISE STACKS NUMBERED 6 AND 7. THESE PIECES WILL BE USED IN LIEU OF THE 40" AND 48" LONG PIECES SHOWN BY THE ALTERNATIVE DETAILS. A SPACER ASSEMBLY, AS SHOWN IN THE "ALTERNATIVE DOORWAY PROTECTION F" DETAIL, MUST BE MODIFIED FOR USE BY CHANGING THE END WHICH EXTENDS OVER THE CROSSWISE CONTAINERS TO BE LIKE THE NEAR END OF THE STRAPPING BOARD SHOWN IN THE "ALTERNATIVE DOORWAY PROTECTION E" DETAIL. A 2" X 4" X 40" DOUBLED BATTEN AS SHOWN IN THAT VIEW IS ALSO REQUIRED. NOTE THAT THE VERTICAL

(CONTINUED AT LEFT)

**LOAD AS SHOWN**

ITEM	QUANTITY	WEIGHT (APPROX)
PALLET UNIT	84	135,576 LBS
DUNNAGE		2,586 LBS
<b>TOTAL WEIGHT</b>		<b>138,162 LBS</b>

FLAT DUNNAGE METHOD UNIT (DECREASED HEIGHT)  
84-UNIT LOAD IN A 60'-8" LONG BY 9'-2" WIDE CONVENTIONAL BOX CAR

DIRECTION OF ARROW INDICATES  
BASE END OF CONTAINERS. SEE  
GENERAL NOTE "E" ON PAGE 2.

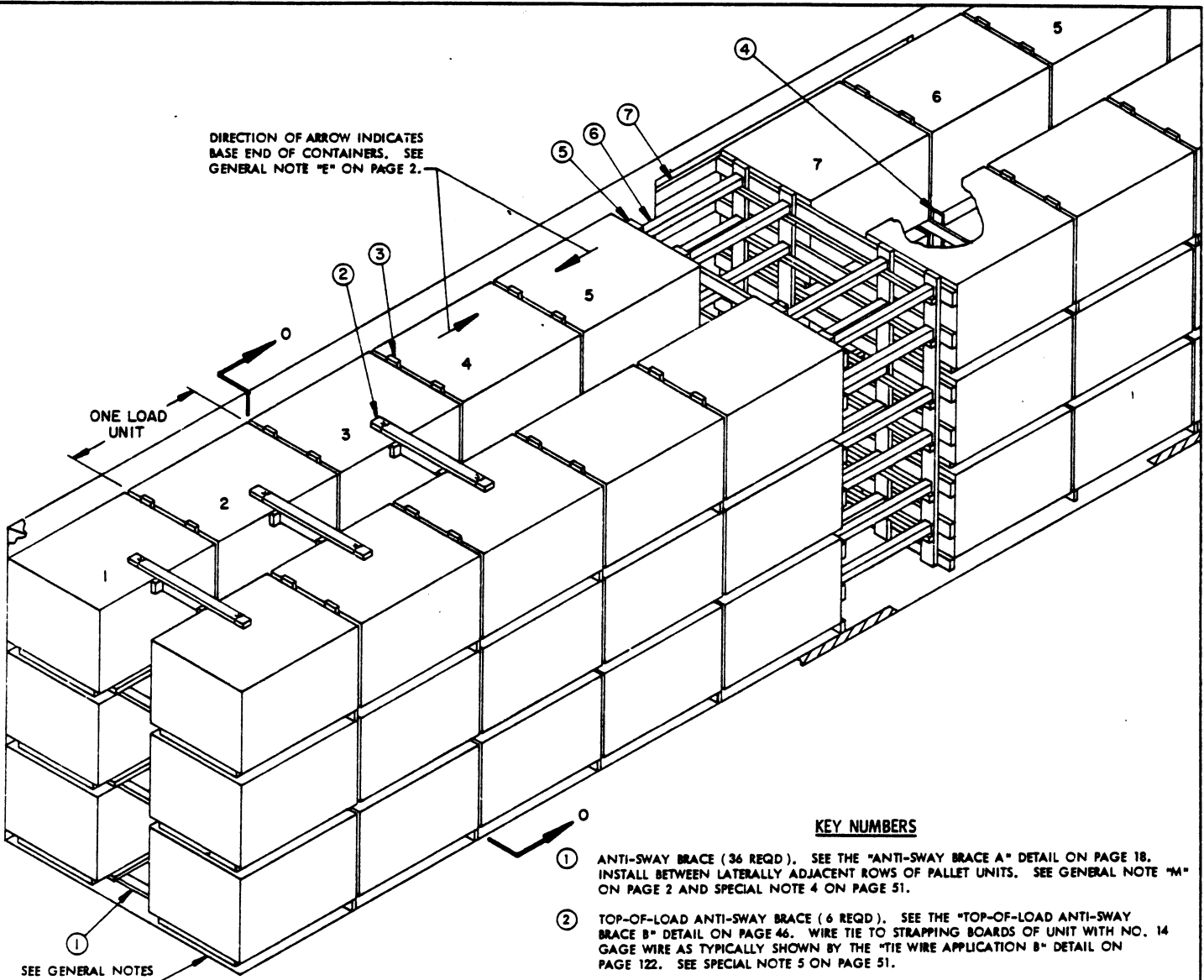

SEE GENERAL NOTES  
"D" AND "G"  
ON PAGE 2.

**ISOMETRIC VIEW**

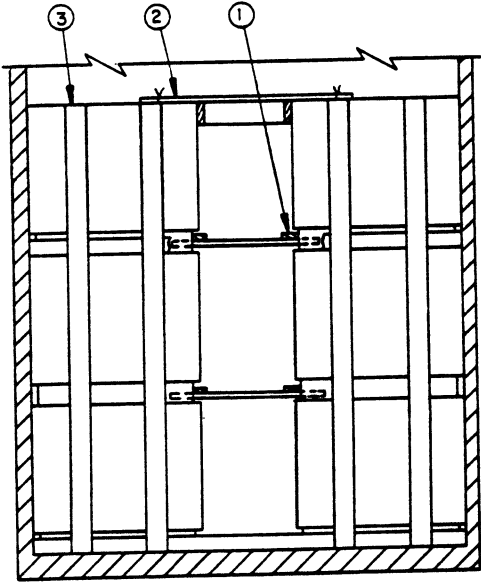

**SECTION O-O**

**KEY NUMBERS**

- ① ANTI-SWAY BRACE (36 REQD). SEE THE "ANTI-SWAY BRACE A" DETAIL ON PAGE 18. INSTALL BETWEEN LATERALLY ADJACENT ROWS OF PALLET UNITS. SEE GENERAL NOTE "M" ON PAGE 2 AND SPECIAL NOTE 4 ON PAGE 51.
- ② TOP-OF-LOAD ANTI-SWAY BRACE (6 REQD). SEE THE "TOP-OF-LOAD ANTI-SWAY BRACE B" DETAIL ON PAGE 46. WIRE TIE TO STRAPPING BOARDS OF UNIT WITH NO. 14 GAGE WIRE AS TYPICALLY SHOWN BY THE "TIE WIRE APPLICATION B" DETAIL ON PAGE 122. SEE SPECIAL NOTE 5 ON PAGE 51.
- ③ SEPARATOR GATE (10 REQD). SEE THE "SEPARATOR GATE H" DETAIL ON PAGE 59. POSITION WITH THE HORIZONTAL PIECES AGAINST THE ALREADY-LOADED UNITS. SEE SPECIAL NOTES 6 AND 8 ON PAGE 51.
- ④ STOP PIECE, 1" X 4" X 7'-0" (2 REQD). INSTALL ON THE SIDE OPPOSITE THE VERTICAL PIECES OF THE SEPARATOR GATE, PIECE MARKED ③, WHICH IS IN THE DOORWAY AREA. POSITION IN CONTACT WITH THE ADJACENT PALLET UNITS AND NAIL TO THE HORIZONTAL PIECES W/3-6d NAILS AT EACH JOINT AND CLINCH. SEE SPECIAL NOTE 7 ON PAGE 51.
- ⑤ CENTER GATE (2 REQD). SEE THE "CENTER GATE P" DETAIL ON PAGE 60. SEE SPECIAL NOTES 9, 10, AND 13 ON PAGE 51.
- ⑥ STRUT, 4" X 4" BY CUT TO FIT (REF: 48") (24 REQD). TOENAIL TO PIECES MARKED ⑤ W/2-16d NAILS AT EACH END. SEE GENERAL NOTES "L", "S", AND "T" ON PAGE 2.
- ⑦ DOORWAY PROTECTION (2 REQD). SEE THE "DOORWAY PROTECTION F" DETAIL ON PAGE 60. NAIL TO THE DOOR POSTS W/12d NAILS. SEE SPECIAL NOTE 12 ON PAGE 51.

FLAT DUNNAGE METHOD UNIT (DECREASED HEIGHT)  
72-UNIT LOAD IN A 60'-8" LONG BY 9'-2" WIDE CONVENTIONAL BOX CAR

(SPECIAL NOTES CONTINUED)

- 12. DOORWAY PROTECTION IS REQUIRED FOR ALL PALLET UNIT STACKS WHICH ARE COMPLETELY WITHIN THE DOORWAY AREA OR WHICH EXTEND INTO THE DOORWAY AREA BY ONE-HALF OR MORE OF THE STACK WIDTH. THE WOODEN GATE TYPE OF DOORWAY PROTECTION, SHOWN AS PIECES MARKED ⑦ IN THE LOAD ON PAGE 50, IS APPLICABLE FOR BOX CARS EQUIPPED WITH CONVENTIONAL SLIDING DOORS AND NAILABLE DOOR POSTS. REFER TO PAGES 126 THRU 128 FOR ALTERNATIVE DOORWAY PROTECTION FOR CARS EQUIPPED WITH CONVENTIONAL SLIDING DOORS. IF THE CAR BEING LOADED IS EQUIPPED WITH PLUG TYPE DOORS, NAILED FLOORLINE BLOCKING AND LOAD BUNDLING STRAPS MUST BE USED. SEE THE "ALTERNATIVE DOORWAY PROTECTION F" DETAIL ON PAGE 128 FOR GUIDANCE. SEE SPECIAL NOTE 13.
- 13. IF THE ALTERNATIVE DOORWAY PROTECTION "F" PROCEDURES SHOWN ON PAGE 128 ARE USED IN LIEU OF THE WOODEN DOORWAY PROTECTION, PIECES MARKED ⑦, THE CENTER GATES MUST BE RESTRAINED FROM LATERAL MOVEMENT. THIS CAN BE ACCOMPLISHED BY NAILING TO THE CAR FLOOR A DOUBLED 2" X 4" X 18" PIECE POSITIONED LONGITUDINALLY SO AS TO BE CENTERED AGAINST THE FILL PIECE OF A CENTER GATE. TWO (2) PIECES WILL BE REQUIRED FOR EACH CENTER GATE WHICH IS IN THE DOOR OPENING OR WITHIN SIX INCHES (6") OF BEING IN THE DOOR OPENING.
- 14. THE DEPICTED LOAD CAN BE REDUCED TO SUIT THE QUANTITY TO BE SHIPPED. A 3-TIER LOAD CAN BE REDUCED BY A MULTIPLE OF SIX (6) PALLET UNITS, OR A 2-TIER LOAD CAN BE REDUCED BY A MULTIPLE OF FOUR (4) UNITS, OR A 1-TIER LOAD CAN BE REDUCED BY A MULTIPLE OF TWO (2) UNITS BY OMITTING ONE OR MORE LOAD UNITS FROM THE CENTER PORTION OF THE LOAD. OR, THE ENTIRE ONE OR TWO TOP TIERS CAN BE OMITTED. FOR OTHER METHODS OF REDUCING A LOAD, AND FOR TYPICAL LCL PROCEDURES, REFER TO PAGES 92 THRU 120 FOR GUIDANCE.
- 15. IF PALLET UNITS WHICH DO NOT CONTAIN A FULL QUANTITY OF CONTAINERS ARE TO BE TRANSPORTED, REFER TO PAGE 117 FOR SHIPPING GUIDANCE.
- 16. FOR SHIPMENT OF ONE OR MORE LEFTOVER CONTAINERS, SEE THE "PROCEDURES FOR SHIPMENT OF LEFTOVER CONTAINERS" ON PAGE 119 FOR GUIDANCE.

SPECIAL NOTES:

- 1. A 60'-8" LONG BY 9'-2" WIDE WOOD-LINED CONVENTIONAL TYPE BOX CAR EQUIPPED WITH 10'-0" WIDE DOOR OPENINGS IS SHOWN. CARS OF OTHER DIMENSIONS AND CARS HAVING WIDER OR NARROWER DOOR OPENINGS CAN BE USED. SEE GENERAL NOTE "D" ON PAGE 2 AND SPECIAL NOTE 3 BELOW.
- 2. THE PALLETIZED UNIT SHOWN IN THE TYPICAL LOAD ON PAGE 50 IS THE FLAT DUNNAGE METHOD UNIT (DECREASED HEIGHT). A MAXIMUM OF SIXTY (60) OF THESE UNITS, FOR AN APPROXIMATE LADING WEIGHT OF 96,840 POUNDS, CAN BE PLACED IN A 50'-6" LONG CAR WHEN USING THE DEPICTED PROCEDURES; FORTY-EIGHT (48) UNITS, FOR AN APPROXIMATE LADING WEIGHT OF 77,472 POUNDS, CAN BE OUTLOADED IN A 40'-6" LONG CAR.
- 3. THE DEPICTED LOADING PATTERN IS ADEQUATE FOR CARS HAVING DOOR OPENINGS 8' THRU 10' OR WIDER. IF THE CAR TO BE LOADED HAS DOOR OPENINGS LESS THAN 8'-0" WIDE AND NOT OF SUFFICIENT HEIGHT TO ALLOW PERSONNEL TO EXIT THE CAR OVER THE TOP OF THE LOAD WHEN NECESSARY, THE PALLETS SHOULD BE POSITIONED SO THERE ARE SIX (6) LOAD UNITS IN EACH END. NOTE THAT ALTHOUGH CARS HAVING DOOR OPENINGS AS NARROW AS 6'-0" WIDE CAN BE USED FOR FULL LOADS, LOADING IS PROGRESSIVELY MORE DIFFICULT AS THE WIDTH OF THE DOOR OPENING DECREASES.
- 4. IF THE "ALTERNATIVE DOORWAY PROTECTION F" PROCEDURES AS SHOWN ON PAGE 128 ARE USED IN LIEU OF THE WOODEN DOOR GATE TYPE PROTECTION, PIECE MARKED ⑦, NAILED FLOORLINE BLOCKING MUST BE USED IN LIEU OF THE LOWER ANTI-SWAY BRACE IN THE DOORWAY AREA. NAILED BLOCKING IS REQUIRED FOR ALL PALLET STACKS WHICH ARE COMPLETELY WITHIN THE DOORWAY AREA OR WHICH EXTEND INTO THE DOORWAY AREA BY ONE-HALF OR MORE OF THE STACK WIDTH ON EITHER SIDE OF THE CAR.
- 5. TOP-OF-LOAD ANTI-SWAY BRACES, SHOWN AS PIECES MARKED ② IN THE LOAD ON PAGE 50, MUST BE INSTALLED IN EACH END OF THE CAR AND WIRE TIED TO A STRAPPING BOARD WITH NO. 14 GAGE WIRE AS TYPICALLY SHOWN BY THE "TIE WIRE APPLICATION B" DETAIL ON PAGE 122. THREE (3) BRACES ARE REQUIRED IN EACH END OF A LOAD REGARDLESS OF THE CAR LENGTH.
- 6. TO FACILITATE POSITIONING OF THE PALLET UNITS AS LOADING PROGRESSES, WHEN LOADING THE BOX CAR, POSITION PALLET UNIT STACKS AGAINST THE END WALL, THEN POSITION A SEPARATOR GATE, SHOWN AS PIECE MARKED ③, SO THE 1" X 4" TIE PIECES ARE LOCATED UNDER THE "OVERHANG" OF THE BOTTOM AND TOP PALLET UNITS. REPEAT THIS PROCEDURE FOR THE REMAINING STACKS.
- 7. SEPARATOR GATES IN THE DOORWAY MUST BE PREVENTED FROM SHIFTING INTO A DOOR OPENING BY THE APPLICATION OF THE STOP PIECES, PIECES MARKED ④. IN CARS EQUIPPED WITH STAGGERED DOORS, STOP PIECES MAY BE REQUIRED ON UP TO FOUR SEPARATOR GATES.
- 8. SEPARATOR GATES MAY BE FORMED FROM 3/8" OR THICKER PLYWOOD IN LIEU OF DIMENSIONAL LUMBER, IF DESIRED, FOR ONE OR TWO-LAYER LOADS; PLYWOOD SEPARATOR GATES FOR A 3-LAYER LOAD ARE NOT ECONOMICALLY FEASIBLE. SEE THE "ALTERNATIVE SEPARATOR GATE" DETAIL ON PAGE 122 FOR CONSTRUCTION GUIDANCE.
- 9. CENTER GATE "P" MAY BE PARTIALLY FORMED FROM 1/2" OR THICKER PLYWOOD IF DESIRED. PLYWOOD MAY BE USED IN LIEU OF THE 2" X 6" HORIZONTAL PIECES. SEE THE "PLYWOOD CENTER GATE ALTERNATIVE" DETAIL ON PAGE 123 FOR GUIDANCE.
- 10. FOR EASE OF HANDLING, SPLIT CENTER GATES, WHICH ARE NOT DEPENDENT UPON THE WIDTH OF THE CAR, MAY BE USED AS AN ALTERNATIVE TO THE CAR-WIDTH GATES. IN LIEU OF EACH "CENTER GATE P", SHOWN AS PIECE MARKED ⑤ IN THE LOAD ON PAGE 50, INSTALL TWO (2) "CENTER GATES N" AS SHOWN ON PAGE 58. AFTER THE SPLIT GATES AND STRUTS HAVE BEEN INSTALLED, THE SPLIT GATES MUST BE TIED TOGETHER AS DEPICTED BY THE "TIE PIECE APPLICATION" DETAIL ON PAGE 123. OMIT THE STOP PIECES FROM "CENTER GATE N".
- 11. DOOR SPANNER TYPE GATE HOLD DOWN MAY BE USED IN LIEU OF THE DOUBLED 2" X 4" MATERIAL NAILED TO CENTER GATE "P" PROVIDING THE CAR BEING LOADED HAS NAILABLE SIDEWALLS. SEE THE DETAILS ON PAGE 125 FOR GUIDANCE.

BILL OF MATERIAL		
LUMBER	LINEAR FEET	BOARD FEET
1" X 4"	197	66
1" X 6"	507	254
2" X 2"	94	32
2" X 3"	36	18
2" X 4"	523	349
2" X 6"	219	219
4" X 4"	100	134
NAILS	NO. REQD	POUNDS
6d (2")	324	2
10d (3")	820	12-3/4
12d (3-1/4")	36	3/4
16d (3-1/2")	96	2-1/4
WIRE, NO. 14 GAGE ----- 60' REQD ----- 1 LB		

(CONTINUED AT LEFT)

LOAD AS SHOWN

ITEM	QUANTITY	WEIGHT (APPROX)
PALLET UNIT -----	72 -----	116,208 LBS
DUNNAGE -----	-----	2,163 LBS
TOTAL WEIGHT -----	-----	118,371 LBS

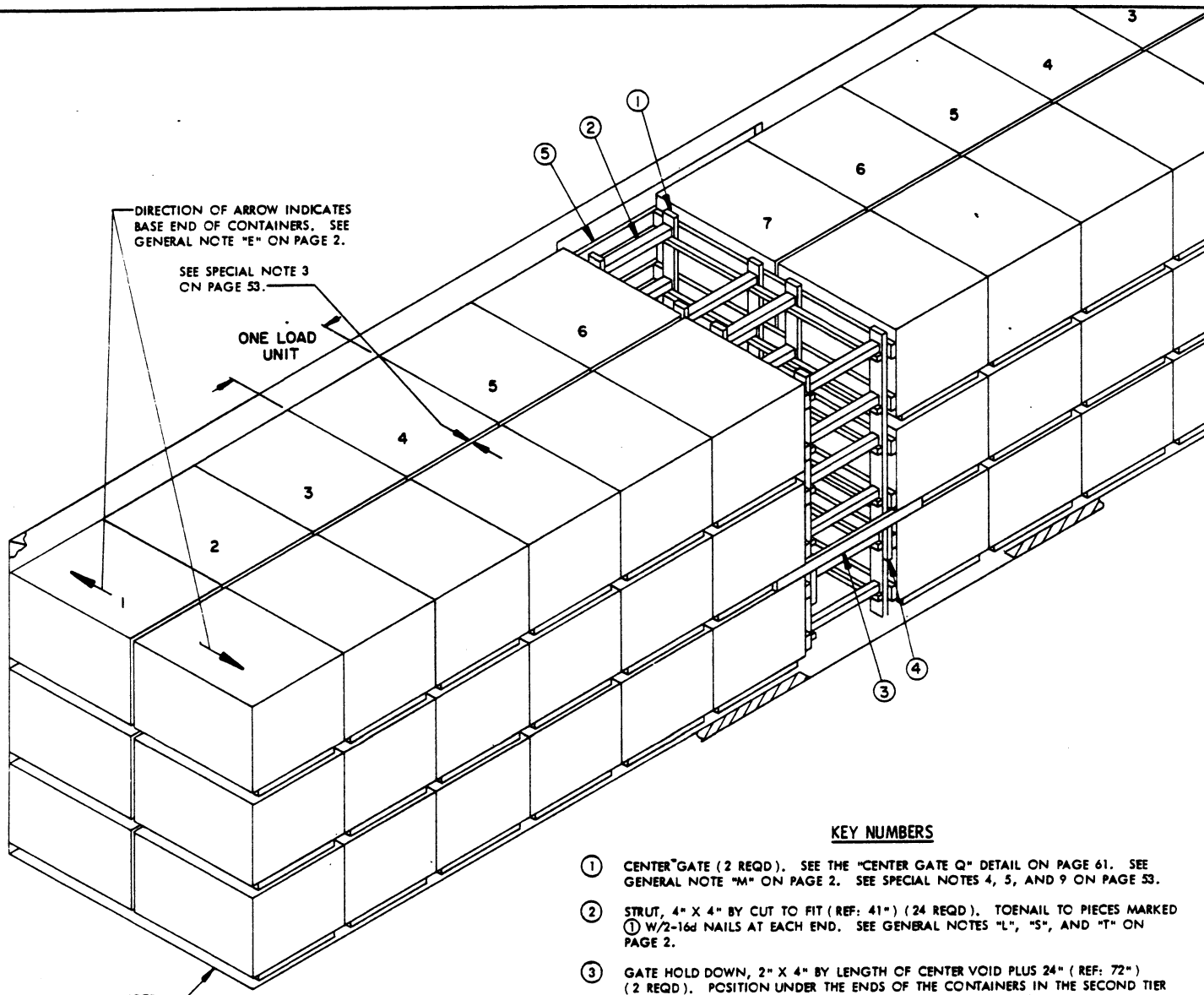

ISOMETRIC VIEW

**KEY NUMBERS**

- ① CENTER GATE (2 REQD). SEE THE "CENTER GATE Q" DETAIL ON PAGE 61. SEE GENERAL NOTE "M" ON PAGE 2. SEE SPECIAL NOTES 4, 5, AND 9 ON PAGE 53.
- ② STRUT, 4" X 4" BY CUT TO FIT (REF: 41") (24 REQD). TOENAIL TO PIECES MARKED ① W/2-16d NAILS AT EACH END. SEE GENERAL NOTES "L", "5", AND "T" ON PAGE 2.
- ③ GATE HOLD DOWN, 2" X 4" BY LENGTH OF CENTER VOID PLUS 24" (REF: 72") (2 REQD). POSITION UNDER THE ENDS OF THE CONTAINERS IN THE SECOND TIER AND NAIL TO THE VERTICAL PIECES OF THE CENTER GATES W/2-10d NAILS AT EACH JOINT. SEE SPECIAL NOTE 6 ON PAGE 53.
- ④ GATE HOLD DOWN SUPPORT PIECE, 2" X 2" X 15" (4 REQD). POSITION UNDER PIECE MARKED ③ AND NAIL TO A VERTICAL PIECE OF PIECE MARKED ① W/4-10d NAILS.
- ⑤ DOORWAY PROTECTION (2 REQD). SEE THE "DOORWAY PROTECTION G" DETAIL ON PAGE 61. NAIL TO THE DOOR POSTS W/12d NAILS. SEE SPECIAL NOTE 7 ON PAGE 53.

SEE GENERAL NOTE "G" ON PAGE 2.

**SPECIAL NOTES:**

1. A 50'-6" LONG BY 9'-4" WIDE WOOD-LINED CONVENTIONAL TYPE BOX CAR EQUIPPED WITH 8'-0" WIDE DOOR OPENINGS IS SHOWN. WIDER CARS OF OTHER LENGTHS AND CARS HAVING WIDER OR NARROWER DOOR OPENINGS CAN BE USED. SEE GENERAL NOTE "D" ON PAGE 2 AND SPECIAL NOTE 9 BELOW.
2. THE PALLETIZED UNIT SHOWN IN THE TYPICAL LOAD ON PAGE 52 IS THE FLAT DUNNAGE METHOD UNIT (DECREASED HEIGHT). A MAXIMUM OF SIXTY (60) OF THESE UNITS, FOR AN APPROXIMATE LADING WEIGHT OF 96,840 POUNDS, CAN BE PLACED IN A 40'-6" LONG CAR WHEN USING THE DEPICTED PROCEDURES. IF A 60'-8" LONG BY 9'-4" OR WIDER CAR IS AVAILABLE, NINETY-SIX (96) PALLET UNITS FOR AN APPROXIMATE LADING WEIGHT OF 154,944 POUNDS CAN BE LOADED. SEE SPECIAL NOTE 9 FOR CENTER GATE MODIFICATIONS WHICH MUST BE MADE IF 60' LONG CARS ARE TO BE USED.
3. ANTI-SWAY BRACING BETWEEN LATERALLY ADJACENT ROWS OF PALLET UNITS IS NOT REQUIRED REGARDLESS OF THE WIDTH OF THE CAR BEING LOADED.
4. CENTER GATE "Q" MAY BE PARTIALLY FORMED FROM 1/2" OR THICKER PLYWOOD, IF DESIRED. PLYWOOD MAY BE USED IN LIEU OF THE 2" X 6" HORIZONTAL PIECES. SEE THE "PLYWOOD CENTER GATE ALTERNATIVE" DETAIL ON PAGE 123 FOR GUIDANCE.
5. FOR EASE OF HANDLING, SPLIT CENTER GATES, WHICH ARE NOT DEPENDENT UPON THE WIDTH OF THE CAR, MAY BE USED AS AN ALTERNATIVE TO THE CAR-WIDTH GATES. IN LIEU OF EACH "CENTER GATE Q", SHOWN AS PIECE MARKED ① IN THE LOAD ON PAGE 52, INSTALL TWO (2) "CENTER GATES C" AS SHOWN ON PAGE 59. AFTER THE SPLIT GATES AND STRUTS HAVE BEEN INSTALLED, THE SPLIT GATES MUST BE TIED TOGETHER AS DEPICTED BY THE "TIE PIECE APPLICATION" DETAIL ON PAGE 123.
6. AN ALTERNATIVE TO THE GATE HOLD DOWN SHOWN AS PIECE MARKED ③ IN THE LOAD ON PAGE 52 MAY BE USED, IF DESIRED, WHEN THE CAR FURNISHED FOR LOADING IS EQUIPPED WITH 8'-0" OR WIDER DOORS. AN ALTERNATIVE MUST BE USED WHEN THE CAR FURNISHED HAS DOOR OPENINGS LESS THAN 8'-0" WIDE. DOOR SPANNER TYPE HOLD DOWN AS SHOWN ON PAGE 125 MAY BE USED, OR HOLD DOWN PIECES MAY BE APPLIED TO THE CENTER GATES AS SHOWN BY THE CENTER GATE "Q" DETAIL ON PAGE 61.
7. DOORWAY PROTECTION IS REQUIRED FOR ALL PALLET UNIT STACKS WHICH ARE COMPLETELY WITHIN THE DOORWAY AREA OR WHICH EXTEND INTO THE DOORWAY AREA BY ONE-HALF OR MORE OF THE STACK LENGTH. THE WOODEN GATE TYPE OF DOORWAY PROTECTION, SHOWN AS PIECES MARKED ⑤ IN THE LOAD ON PAGE 52, IS APPLICABLE FOR BOX CARS EQUIPPED WITH CONVENTIONAL SLIDING DOORS AND NAILABLE DOOR POSTS. REFER TO PAGES 126 THRU 128 FOR ALTERNATIVE DOORWAY PROTECTION FOR CARS EQUIPPED WITH CONVENTIONAL SLIDING DOORS. IF THE CAR BEING LOADED IS EQUIPPED WITH PLUG TYPE DOORS, NAILED FLOORLINE BLOCKING AND LOAD BUNDLING STRAPS MUST BE USED. SEE THE "ALTERNATIVE DOORWAY PROTECTION E" DETAIL ON PAGE 128 FOR GUIDANCE.
8. THE DEPICTED LOAD CAN BE REDUCED TO SUIT THE QUANTITY TO BE SHIPPED. A 3-TIER LOAD CAN BE REDUCED BY A MULTIPLE OF SIX (6) PALLET UNITS, A 2-TIER LOAD CAN BE REDUCED BY A MULTIPLE OF FOUR (4) UNITS, OR A 1-TIER LOAD CAN BE REDUCED BY A MULTIPLE OF TWO (2) UNITS BY OMITTING ONE OR MORE LOAD UNITS FROM THE CENTER PORTION OF THE LOAD. OR, THE ENTIRE ONE OR TWO TOP TIERS CAN BE OMITTED. FOR OTHER METHODS OF REDUCING A LOAD, AND FOR TYPICAL LCL PROCEDURES, REFER TO PAGES 92 THRU 120 FOR GUIDANCE.
9. IF A FULL LOAD IS TO BE SHIPPED IN A 60' LONG CAR, SIX (6) STRUTS ARE REQUIRED FOR EACH ROW/TIER. TO ACCOMMODATE THESE ADDITIONAL STRUTS, A STRUT LEDGER MUST BE ADDED TO CENTER GATE "Q" FOR EACH TIER AS SHOWN BY THE PHANTOMED LINES ON THE DETAIL ON PAGE 61.
10. IF PALLET UNITS WHICH DO NOT CONTAIN A FULL QUANTITY OF CONTAINERS ARE TO BE TRANSPORTED, REFER TO PAGES 118 AND 120 FOR SHIPPING GUIDANCE.
11. FOR SHIPMENT OF ONE OR MORE LEFTOVER CONTAINERS, SEE THE "PROCEDURES FOR SHIPMENT OF LEFTOVER CONTAINERS" ON PAGE 119 FOR GUIDANCE.

**BILL OF MATERIAL**

LUMBER	LINEAR FEET	BOARD FEET
1" X 6"	96	48
2" X 2"	112	38
2" X 3"	36	18
2" X 4"	12	8
2" X 6"	184	184
4" X 4"	82	110
NAILS	NO. REQD	POUNDS
6d (2")	72	1/2
10d (3")	264	4-1/4
12d (3-1/4")	36	3/4
16d (3-1/2")	96	2-1/4

**LOAD AS SHOWN**

ITEM	QUANTITY	WEIGHT (APPROX)
PALLET UNIT -----	78 -----	125,892 LBS
DUNNAGE -----	-----	820 LBS
<b>TOTAL WEIGHT -----</b>	<b>-----</b>	<b>126,712 LBS</b>

FLAT DUNNAGE METHOD UNIT (DECREASED HEIGHT)  
78-UNIT LOAD IN A 50'-6" LONG BY 9'-4" WIDE CONVENTIONAL BOX CAR

**CAR EQUIPMENT REQUIRED**

ADJUSTABLE WALL MEMBER (SEE "NOTE 1" BELOW)	40
CROSS MEMBER	28
DOORWAY MEMBER	8

NOTE 1: FOR CARS EQUIPPED WITH FIXED WALL MEMBERS LOCATED AT THE HEIGHTS SPECIFIED IN "SECTION P-P", OMIT ALL REFERENCE TO "ADJUSTABLE WALL MEMBERS".

DIRECTION OF ARROW INDICATES BASE END OF CONTAINERS. SEE GENERAL NOTE "E" ON PAGE 2.

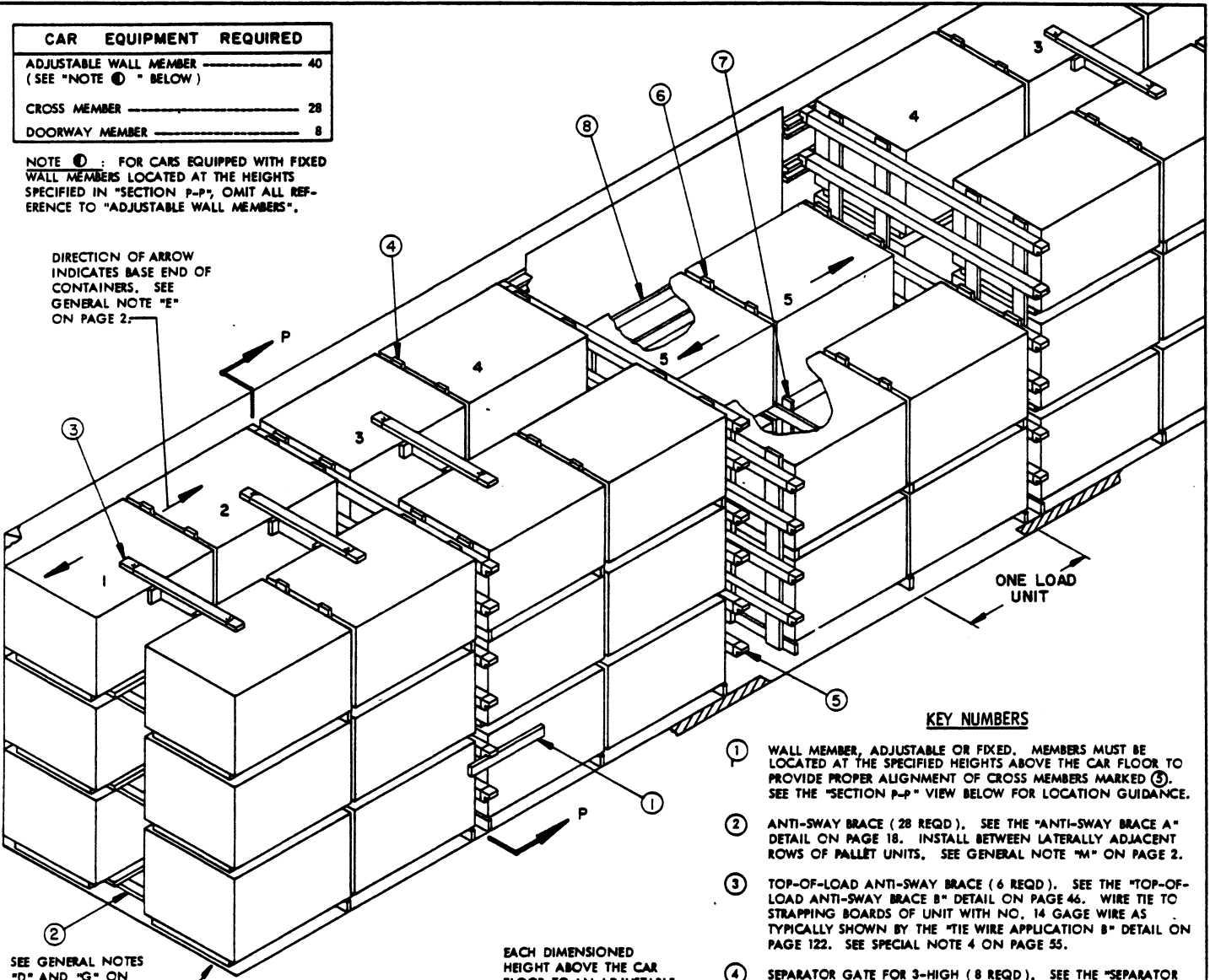

SEE GENERAL NOTES "D" AND "G" ON PAGE 2 AND SPECIAL NOTE 3 ON PAGE 55.

**ISOMETRIC VIEW**

EACH DIMENSIONED HEIGHT ABOVE THE CAR FLOOR TO AN ADJUSTABLE OR FIXED WALL MEMBER MARKED 1 AND/OR A DOORWAY MEMBER MARKED 8 IS SPECIFIED TO LOCATE THE CENTER LINE OF A CROSS MEMBER.

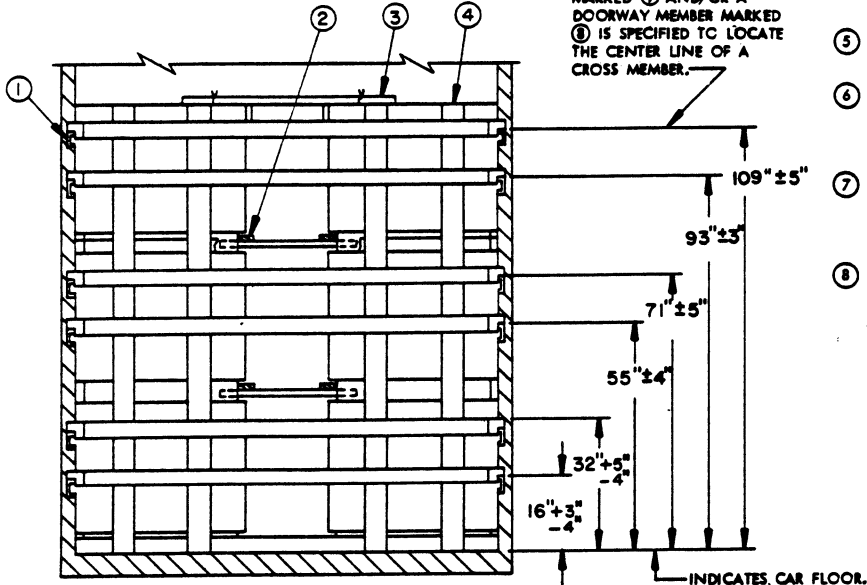

**SECTION P-P**

**KEY NUMBERS**

- 1 WALL MEMBER, ADJUSTABLE OR FIXED. MEMBERS MUST BE LOCATED AT THE SPECIFIED HEIGHTS ABOVE THE CAR FLOOR TO PROVIDE PROPER ALIGNMENT OF CROSS MEMBERS MARKED 3. SEE THE "SECTION P-P" VIEW BELOW FOR LOCATION GUIDANCE.
- 2 ANTI-SWAY BRACE (28 REQD). SEE THE "ANTI-SWAY BRACE A" DETAIL ON PAGE 18. INSTALL BETWEEN LATERALLY ADJACENT ROWS OF PALLET UNITS. SEE GENERAL NOTE "M" ON PAGE 2.
- 3 TOP-OF-LOAD ANTI-SWAY BRACE (6 REQD). SEE THE "TOP-OF-LOAD ANTI-SWAY BRACE B" DETAIL ON PAGE 46. WIRE TIE TO STRAPPING BOARDS OF UNIT WITH NO. 14 GAGE WIRE AS TYPICALLY SHOWN BY THE "TIE WIRE APPLICATION B" DETAIL ON PAGE 122. SEE SPECIAL NOTE 4 ON PAGE 55.
- 4 SEPARATOR GATE FOR 3-HIGH (8 REQD). SEE THE "SEPARATOR GATE H" DETAIL ON PAGE 59. AS APPLICABLE, POSITION WITH THE HORIZONTAL PIECES AGAINST THE ALREADY-LOADED UNITS. SEE SPECIAL NOTES 5 AND 7 ON PAGE 55.
- 5 CROSS MEMBER (28 REQD). SEE GENERAL NOTE "W" ON PAGE 3.
- 6 SEPARATOR GATE FOR 2-HIGH (3 REQD). SEE THE "SEPARATOR GATE H" DETAIL ON PAGE 59. AS APPLICABLE, POSITION WITH THE HORIZONTAL PIECES AGAINST THE ALREADY-LOADED UNITS. SEE SPECIAL NOTES 5 THRU 7 ON PAGE 55.
- 7 STOP PIECE, 1" X 4" X 48" (4 REQD). POSITION AGAINST PALLET UNITS IN THE DOORWAY AND NAIL TO THE HORIZONTAL PIECES OF PIECE MARKED 4 W/3-6d NAILS AT EACH JOINT AND CLINGH. SEE SPECIAL NOTE 6 ON PAGE 55.
- 8 DOORWAY MEMBER (8 REQD). SEE THE "SECTION P-P" VIEW AT LEFT FOR LOCATION GUIDANCE. SEE SPECIAL NOTE 8 ON PAGE 55.

FLAT DUNNAGE METHOD UNIT (DECREASED HEIGHT)

56-UNIT LOAD IN A 50'-6" LONG BY 9'-0" WIDE BOX CAR EQUIPPED WITH MECHANICAL BRACING DEVICES

**SPECIAL NOTES:**

1. A 50'-6" LONG BY 9'-0" WIDE (INSIDE CLEARANCE) WOOD-LINED BOX CAR EQUIPPED WITH ADJUSTABLE AND/OR FIXED WALL MEMBERS, AND WITH 10'-0" WIDE DOOR OPENINGS IS SHOWN. CARS OF OTHER DIMENSIONS AND CARS HAVING WIDER OR NARROWER DOOR OPENINGS CAN BE USED. SEE GENERAL NOTE "D" ON PAGE 2.
2. THE PALLETIZED UNIT SHOWN IN THE TYPICAL LOAD ON PAGE 54 IS THE FLAT DUNNAGE METHOD UNIT (DECREASED HEIGHT). A MAXIMUM OF FORTY-FOUR (44) OF THESE UNITS, FOR AN APPROXIMATE LADING WEIGHT OF 71,016 POUNDS, CAN BE PLACED IN A 40'-6" LONG CAR.
3. IF A CAR HAS BOWED END WALLS WHICH ARE BOWED OUTWARD TWO INCHES (2") OR MORE EITHER FROM SIDE-TO-SIDE OR FROM FLOOR-TO-ROOF, CROSS MEMBERS CAN BE INSTALLED NEAR THE END WALL OF THE CAR TO PROVIDE A "SQUARED END" RATHER THAN INSTALLING DUNNAGE AS SPECIFIED IN GENERAL NOTE "G" ON PAGE 2. THESE CROSS MEMBERS SHOULD BE INSTALLED AT THE SAME HEIGHTS AS THE CROSS MEMBERS USED THROUGHOUT THE LOAD AS BLOCKING MEMBERS. A SEPARATOR GATE, SHOWN AS PIECE MARKED (4), MUST BE POSITIONED AGAINST THESE CROSS MEMBERS PRIOR TO LOADING.
4. TOP-OF-LOAD ANTI-SWAY BRACES, SHOWN AS PIECES MARKED (3) IN THE LOAD ON PAGE 54, MUST BE INSTALLED IN EACH END OF THE CAR AND WIRE TIED TO THE STRAPPING BOARDS WITH NO. 14 GAGE WIRE AS TYPICALLY SHOWN BY THE "TIE WIRE APPLICATION B" DETAIL ON PAGE 122. THREE (3) BRACES ARE REQUIRED IN EACH END OF A LOAD REGARDLESS OF THE CAR LENGTH.
5. TO FACILITATE POSITIONING OF THE PALLET UNITS AS LOADING PROGRESSES, POSITION PALLET UNIT STACKS AGAINST THE END WALL, THEN POSITION A SEPARATOR GATE, SHOWN AS PIECE MARKED (4), SO THE 1" X 4" TIE PIECES ARE LOCATED UNDER THE "OVERHANG" OF THE BOTTOM AND TOP PALLET UNITS. REPEAT THIS PROCEDURE FOR THE REMAINING STACKS.
6. SEPARATOR GATES IN THE DOORWAY MUST BE PREVENTED FROM SHIFTING INTO A DOOR OPENING BY THE APPLICATION OF THE STOP PIECES, PIECES MARKED (7). IN CARS EQUIPPED WITH STAGGERED DOORS, STOP PIECES MAY BE REQUIRED ON UP TO FOUR SEPARATOR GATES.
7. SEPARATOR GATES MAY BE FORMED FROM 3/8" OR THICKER PLYWOOD IN LIEU OF DIMENSIONAL LUMBER, IF DESIRED, FOR ONE OR TWO-LAYER LOADS; PLYWOOD SEPARATOR GATES FOR A 3-LAYER LOAD ARE NOT ECONOMICALLY FEASIBLE. SEE THE "ALTERNATIVE SEPARATOR GATE" DETAIL ON PAGE 122 FOR CONSTRUCTION GUIDANCE.
8. IF THE CAR BEING LOADED IS EQUIPPED WITH AT LEAST TWELVE (12) DOORWAY MEMBERS, AN ADDITIONAL FOUR PALLET UNITS CAN BE LOADED IN THE DOORWAY AREA.
9. THE DEPICTED LOAD CAN BE REDUCED TO SUIT THE QUANTITY TO BE SHIPPED. A LOAD MAY BE REDUCED BY MULTIPLES OF TWO (2) PALLET UNITS BY OMITTING LATERALLY ADJACENT UNITS FROM THE TOP ONE OR TWO LAYERS OF ONE OR MORE LOAD UNITS, OR BY MULTIPLES OF SIX (6) PALLET UNITS BY OMITTING ONE OR MORE ENTIRE LOAD UNITS. TO REDUCE A LOAD BY ONE (1) PALLET UNIT, REFER TO THE LCL PROCEDURES ON PAGES 90 AND 91 FOR GUIDANCE.
10. FOR SHIPMENT OF ONE OR MORE LEFTOVER CONTAINERS, SEE THE "PROCEDURES FOR SHIPMENT OF LEFTOVER CONTAINERS" ON PAGE 119 FOR GUIDANCE.

BILL OF MATERIAL		
LUMBER	LINEAR FEET	BOARD FEET
1" X 4"	214	72
1" X 6"	388	194
2" X 4"	381	254
2" X 6"	18	18
NAILS	NO. REQD	POUNDS
6d (2")	276	1-3/4
10d (3")	420	6-1/2
WIRE, NO. 14 GAGE ----- 60' REQD ----- 1 LB		

**LOAD AS SHOWN**

ITEM	QUANTITY	WEIGHT (APPROX)
PALLET UNIT -----	56 -----	90,384 LBS
DUNNAGE -----	-----	1,086 LBS
TOTAL WEIGHT -----		91,470 LBS

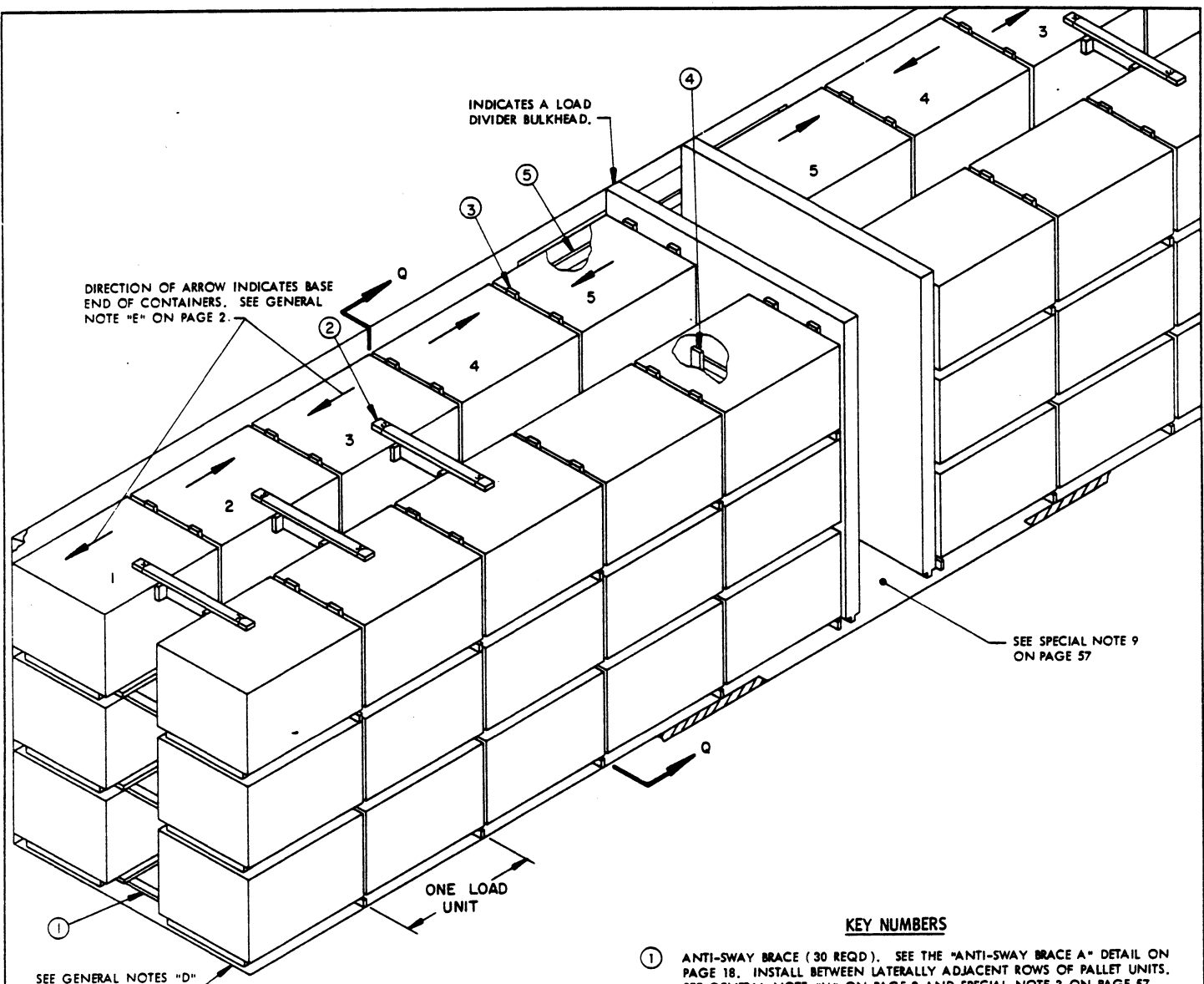

SEE GENERAL NOTES "D" AND "G" ON PAGE 2.

**ISOMETRIC VIEW**

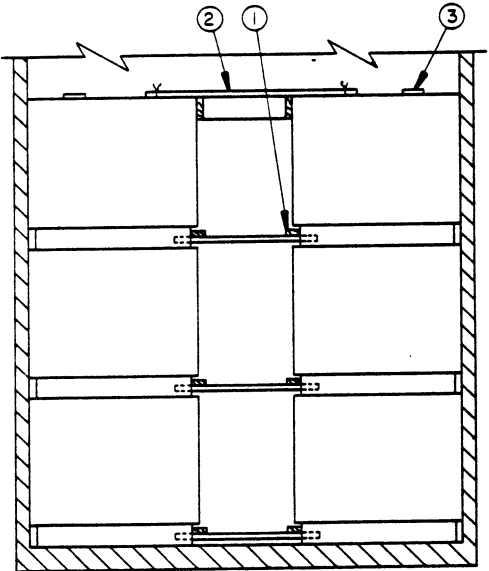

**SECTION Q-Q**

**KEY NUMBERS**

- ① ANTI-SWAY BRACE (30 REQD). SEE THE "ANTI-SWAY BRACE A" DETAIL ON PAGE 18. INSTALL BETWEEN LATERALLY ADJACENT ROWS OF PALLET UNITS. SEE GENERAL NOTE "M" ON PAGE 2 AND SPECIAL NOTE 3 ON PAGE 57.
- ② TOP-OF-LOAD ANTI-SWAY BRACE (6 REQD). SEE THE "TOP-OF-LOAD ANTI-SWAY BRACE B" DETAIL ON PAGE 46. WIRE TIE TO STRAPPING BOARDS WITH NO. 14 GAGE WIRE AS TYPICALLY SHOWN BY THE "TIE WIRE APPLICATION B" DETAIL ON PAGE 122. SEE SPECIAL NOTE 4 ON PAGE 57.
- ③ SEPARATOR GATE (10 REQD). SEE THE "SEPARATOR GATE H" DETAIL ON PAGE 59. POSITION WITH THE HORIZONTAL PIECES AGAINST THE ALREADY-LOADED UNITS. SEE SPECIAL NOTES 5 AND 7 ON PAGE 57.
- ④ STOP PIECE, 1" X 4" X 7'-0" (4 REQD). NAIL TO THE HORIZONTAL PIECES ON PIECE MARKED ③ W/3-6d NAILS AT EACH JOINT AND CLINCH. SEE SPECIAL NOTE 6 ON PAGE 57.
- ⑤ DOORWAY PROTECTION (2 REQD). SEE THE "DOORWAY PROTECTION F" DETAIL ON PAGE 60. NAIL TO THE DOOR POSTS W/12d NAILS. SEE SPECIAL NOTE 8 ON PAGE 57.

SEE SPECIAL NOTE 9 ON PAGE 57

**FLAT DUNNAGE METHOD UNIT (DECREASED HEIGHT)  
60-UNIT LOAD IN A 50'-6" LONG BY 9'-2" WIDE BOX CAR EQUIPPED WITH LOAD DIVIDERS**



( SPECIAL NOTES CONTINUED )

10. THE DEPICTED LOAD CAN BE REDUCED TO SUIT THE QUANTITY TO BE SHIPPED. A 3-TIER LOAD CAN BE REDUCED BY A MULTIPLE OF SIX (6) PALLET UNITS, OR A 2-TIER LOAD CAN BE REDUCED BY A MULTIPLE OF FOUR (4) UNITS, OR A 1-TIER LOAD CAN BE REDUCED BY A MULTIPLE OF TWO (2) UNITS BY OMITTING ONE OR MORE LOAD UNITS FROM THE CENTER PORTION OF THE LOAD. OR, THE ENTIRE ONE OR TWO TOP TIERS CAN BE OMITTED. FOR OTHER METHODS OF REDUCING A LOAD, AND FOR TYPICAL LCL PROCEDURES, REFER TO PAGES 94 THRU 105 AND GENERAL NOTE "FF" ON PAGE 3 FOR GUIDANCE.
11. IF PALLET UNITS WHICH DO NOT CONTAIN A FULL QUANTITY OF CONTAINERS ARE TO BE TRANSPORTED, REFER TO PAGE 117 AND/OR PAGES 118 AND 120 FOR SHIPPING GUIDANCE.
12. FOR SHIPMENT OF ONE OR MORE LEFTOVER CONTAINERS, SEE THE "PROCEDURES FOR SHIPMENT OF LEFTOVER CONTAINERS" ON PAGE 119 FOR GUIDANCE.

SPECIAL NOTES:

1. A 50'-6" LONG BY 9'-2" WIDE WOOD-LINED CUSHIONED BOX CAR EQUIPPED WITH LOAD DIVIDER BULKHEADS AND WITH 10'-0" WIDE DOOR OPENINGS IS SHOWN. CARS OF OTHER DIMENSIONS AND CARS HAVING NARROWER OR WIDER DOOR OPENINGS CAN BE USED. SEE GENERAL NOTES "AA THRU "EE ON PAGE 3.
2. THE PALLET UNIT SHOWN IN THE TYPICAL LOAD ON PAGE 56 IS THE FLAT DUNNAGE METHOD UNIT ( DECREASED HEIGHT ). A MAXIMUM OF SEVENTY-TWO ( 72 ) OF THESE UNITS, FOR AN APPROXIMATE LADING WEIGHT OF 116,208 POUNDS, CAN BE PLACED IN A 60'-8" LONG CAR, OR A MAXIMUM OF FORTY-EIGHT ( 48 ) UNITS CAN BE LOADED IN A 40'-6" CAR FOR AN APPROXIMATE LADING WEIGHT OF 77,472 POUNDS, WHEN USING THE DEPICTED PROCEDURES. IF CARS 9'-4" OR WIDER ARE AVAILABLE, THE CROSSWISE LOADING PATTERN SHOWN ON PAGE 32 MAY BE EMPLOYED. THEN, NINETY-SIX ( 96 ) PALLET UNITS FOR AN APPROXIMATE LADING WEIGHT OF 154,944 POUNDS CAN BE PLACED IN A 60'-8" LONG CAR, SEVENTY-EIGHT ( 78 ) UNITS CAN BE PLACED IN A 50'-6" LONG CAR FOR AN APPROXIMATE LADING WEIGHT OF 125,892 POUNDS, AND SIXTY ( 60 ) UNITS CAN BE LOADED IN A 40'-6" LONG CAR FOR AN APPROXIMATE LADING WEIGHT OF 96,840 POUNDS.
3. IF THE "ALTERNATIVE DOORWAY PROTECTION F" PROCEDURES AS SHOWN ON PAGE 128 ARE USED IN LIEU OF THE WOODEN DOOR GATE TYPE PROTECTION, PIECE MARKED ⑤ , NAILED FLOORLINE BLOCKING MUST BE USED IN LIEU OF THE LOWER ANTI-SWAY BRACE IN THE DOORWAY AREA. NAILED BLOCKING IS REQUIRED FOR ALL PALLET STACKS WHICH ARE COMPLETELY WITHIN THE DOORWAY AREA OR WHICH EXTEND INTO THE DOORWAY AREA BY ONE-HALF OR MORE OF THE STACK WIDTH ON EITHER SIDE OF THE CAR.
4. TOP-OF-LOAD ANTI-SWAY BRACES, SHOWN AS PIECES MARKED ② IN THE LOAD ON PAGE 56, MUST BE INSTALLED IN EACH END OF THE CAR AND WIRE TIED TO STRAPPING BOARDS WITH NO. 14 GAGE WIRE AS TYPICALLY SHOWN BY THE "TIE WIRE APPLICATION B" DETAIL ON PAGE 122. THREE ( 3 ) BRACES ARE REQUIRED IN EACH END OF A LOAD REGARDLESS OF THE CAR LENGTH.
5. TO FACILITATE POSITIONING OF THE PALLET UNITS AS LOADING PROGRESSES, POSITION PALLET UNIT STACKS AGAINST THE END WALL, THEN POSITION A SEPARATOR GATE SHOWN AS PIECE MARKED ③ , SO THE 1" X 4" TIE PIECES ARE LOCATED UNDER THE "OVERHANG" OF THE BOTTOM AND TOP PALLET UNITS. REPEAT THIS PROCEDURE FOR THE REMAINING STACKS.
6. SEPARATOR GATES IN THE DOORWAY MUST BE PREVENTED FROM SHIFTING INTO A DOOR OPENING BY THE APPLICATION OF THE STOP PIECES, PIECES MARKED ④ IN CARS EQUIPPED WITH STAGGERED DOORS, STOP PIECES MAY BE REQUIRED ON UP TO FOUR SEPARATOR GATES.
7. SEPARATOR GATES MAY BE FORMED FROM 3/8" OR THICKER PLYWOOD IN LIEU OF DIMENSIONAL LUMBER, IF DESIRED. SEE THE "ALTERNATIVE SEPARATOR GATE" DETAIL ON PAGE 122 FOR CONSTRUCTION GUIDANCE.
8. DOORWAY PROTECTION IS REQUIRED FOR ALL PALLET UNIT STACKS WHICH ARE COMPLETELY WITHIN THE DOORWAY AREA OR WHICH EXTEND INTO THE DOORWAY AREA BY ONE-HALF OR MORE OF THE STACK WIDTH. THE WOODEN GATE TYPE OF DOORWAY PROTECTION, SHOWN AS PIECES MARKED ⑤ IN THE LOAD ON PAGE 56, IS APPLICABLE FOR BOX CARS EQUIPPED WITH CONVENTIONAL SLIDING DOORS AND NAILABLE DOOR POSTS. REFER TO PAGES 126 THRU 128 FOR ALTERNATIVE DOORWAY PROTECTION FOR CARS EQUIPPED WITH CONVENTIONAL SLIDING DOORS. IF THE CAR BEING LOADED IS EQUIPPED WITH PLUG TYPE DOORS NAILED FLOORLINE BLOCKING AND LOAD BUNDLING STRAPS MUST BE USED. SEE THE "ALTERNATIVE DOORWAY PROTECTION F" DETAIL ON PAGE 128 FOR GUIDANCE IF THE PALLET UNITS ARE POSITIONED AS SHOWN ON PAGE 56. SEE THE "ALTERNATIVE DOORWAY PROTECTION E" DETAIL ON THAT PAGE IF THE PALLET UNITS ARE POSITIONED CROSSWISE.
9. A STRUT ASSEMBLY, SHOWN AS PIECE MARKED ⑥ IN THE LOAD ON PAGE 42, IS REQUIRED BETWEEN THE LOAD DIVIDER BULKHEADS WHEN THE LOAD IN EITHER END OF THE CAR IS 50,000 POUNDS OR MORE. FOR THE DEPICTED PALLET UNIT, A STRUT ASSEMBLY WILL BE REQUIRED IF THE LOAD IN ONE END OF THE CAR CONSISTS OF MORE THAN FIVE ( 5 ) LOAD UNITS, WHICH WOULD BE THE CASE IF AN OFFSET LOADING PATTERN IS EMPLOYED. THE STRUT ASSEMBLY WILL ALWAYS BE REQUIRED FOR FULL LOADS IN 60' OR LONGER CARS.

( CONTINUED AT LEFT )

BILL OF MATERIAL		
LUMBER	LINEAR FEET	BOARD FEET
1" X 4"	211	71
1" X 6"	507	254
2" X 3"	36	18
2" X 4"	418	279
2" X 6"	20	20
NAILS	NO. REQD	POUNDS
6d ( 2" )	366	2-1/4
10d ( 3" )	444	7
12d ( 3-1/4" )	36	3/4
WIRE, NO. 14 GAGE-----	60' REQD-----	1 LB

LOAD AS SHOWN

ITEM	QUANTITY	WEIGHT ( APPROX )
PALLET UNIT -----	60-----	96,840 LBS
DUNNAGE-----	-----	1,295 LBS
TOTAL WEIGHT -----		98,135 LBS

FLAT DUNNAGE METHOD UNIT ( DECREASED HEIGHT )  
60-UNIT LOAD IN A 50'-6" LONG BY 9'-2" WIDE BOX CAR EQUIPPED WITH LOAD DIVIDERS

STRUT, 2" X 4" BY A LENGTH TO SUIT (6 REQD). NAIL TO THE STRUT SUPPORT PIECES W/2-10d NAILS AT EACH END.

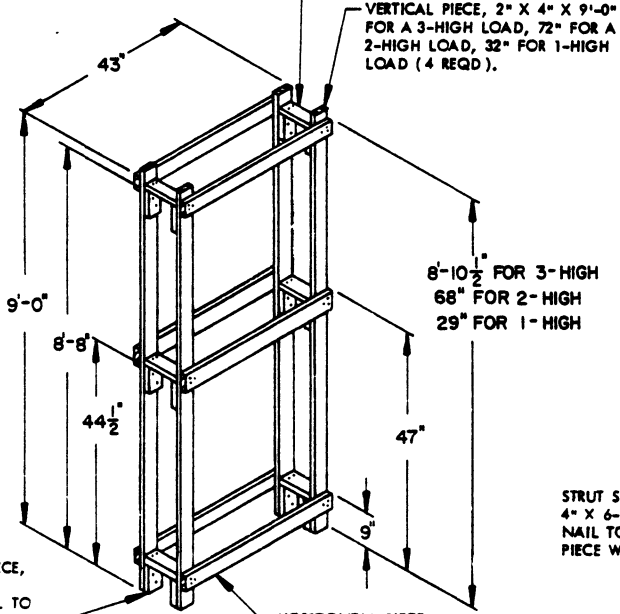

**CRIB FILL G**

STRUT SUPPORT PIECE, 2" X 4" X 6-1/2" (12 REQD). NAIL TO A VERTICAL PIECE W/2-10d NAILS.

HORIZONTAL PIECE, 2" X 4" X 43" (6 REQD). NAIL TO THE VERTICAL PIECES W/3-10d NAILS AT EACH END.

VERTICAL PIECE, 2" X 4" X 7'-4" FOR A 2-HIGH LOAD, 50" FOR A 1-HIGH LOAD (4 REQD).

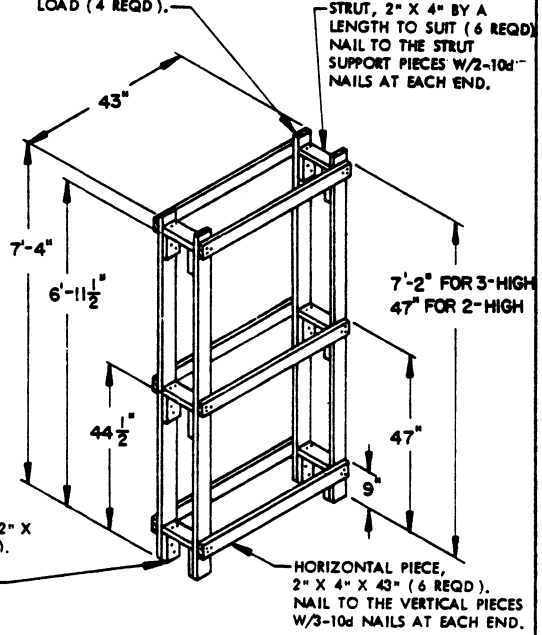

**CRIB FILL H**

OMIT THE MID-HEIGHT HORIZONTAL PIECES, STRUTS, AND STRUT SUPPORT PIECES, WHEN USING CRIB FOR A 2-HIGH LOAD. CRIB FILL "H" IS NOT REQUIRED FOR A 1-HIGH LOAD; USE CRIB FILL "G" THROUGHOUT THE LENGTH OF THE LOAD.

STRUT SUPPORT PIECE, 2" X 4" X 6-1/2" (12 REQD). NAIL TO A VERTICAL PIECE W/2-10d NAILS.

HORIZONTAL PIECE, 2" X 4" X 43" (6 REQD). NAIL TO THE VERTICAL PIECES W/3-10d NAILS AT EACH END.

CRIB FILL ASSEMBLIES "G" AND "H" SHOULD BE PRE-ASSEMBLED. CONSTRUCT TO BE 1/2" TO 3/4" LESS IN WIDTH THAN THE DISTANCE BETWEEN LATERALLY ADJACENT ROWS OF PALLET UNITS. OMIT THE MID-HEIGHT HORIZONTAL PIECES, STRUTS, AND STRUT SUPPORT PIECES WHEN USING CRIB FOR A 1 OR 2 HIGH LOAD.

VERTICAL PIECE, 2" X 6" X 9'-3" FOR A 3-HIGH LOAD, 6'-2" FOR A 2-HIGH LOAD, 36" FOR A 1-HIGH LOAD (2 REQD).

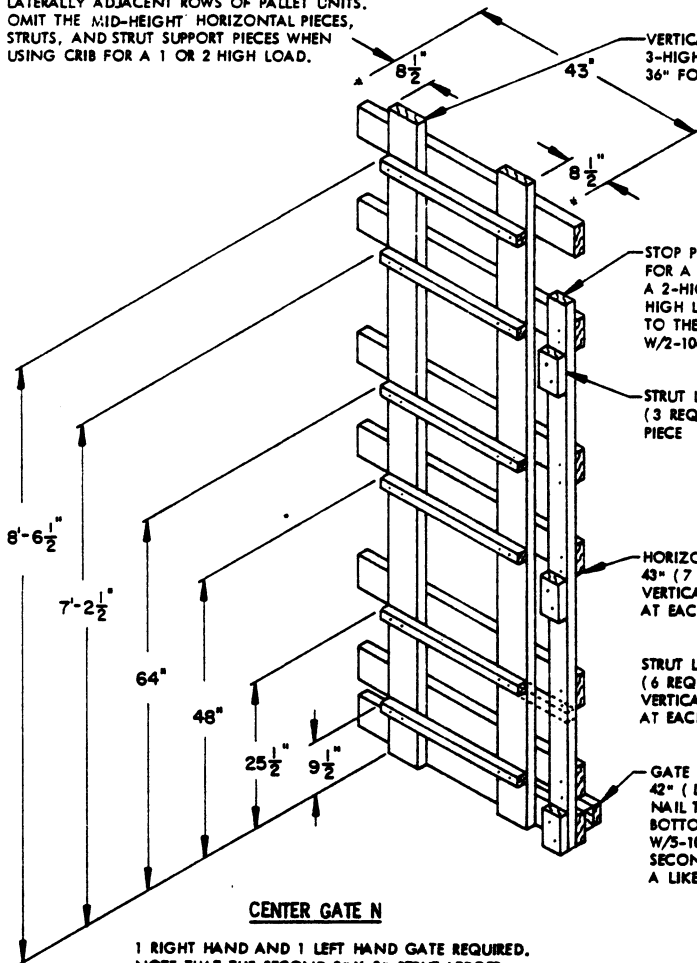

**CENTER GATE N**

1 RIGHT HAND AND 1 LEFT HAND GATE REQUIRED. NOTE THAT THE SECOND 2" X 2" STRUT LEDGER FROM THE BOTTOM MUST BE 34-1/2" LONG, AS SHOWN BY THE PHANTOM LINES, FOR A 1-HIGH LOAD.

STOP PIECE, 2" X 4" X 7'-10" FOR A 3-HIGH LOAD, 72" FOR A 2-HIGH LOAD, 32" FOR A 1-HIGH LOAD (1 REQD). NAIL TO THE HORIZONTAL PIECES W/2-10d NAILS AT EACH JOINT.

STRUT LEDGER, 2" X 4" X 6-1/2" (3 REQD). NAIL TO THE STOP PIECE W/2-10d NAILS.

HORIZONTAL PIECE, 2" X 6" X 43" (7 REQD). NAIL TO THE VERTICAL PIECES W/3-10d NAILS AT EACH JOINT.

STRUT LEDGER, 2" X 2" X 26" (6 REQD). NAIL TO THE VERTICAL PIECES W/2-10d NAILS AT EACH END.

GATE HOLD DOWN, 2" X 4" X 42" (DOUBLED) (1 REQD). NAIL THE FIRST PIECE TO THE BOTTOM HORIZONTAL PIECE W/5-10d NAILS. LAMINATE THE SECOND PIECE TO THE FIRST IN A LIKE MANNER.

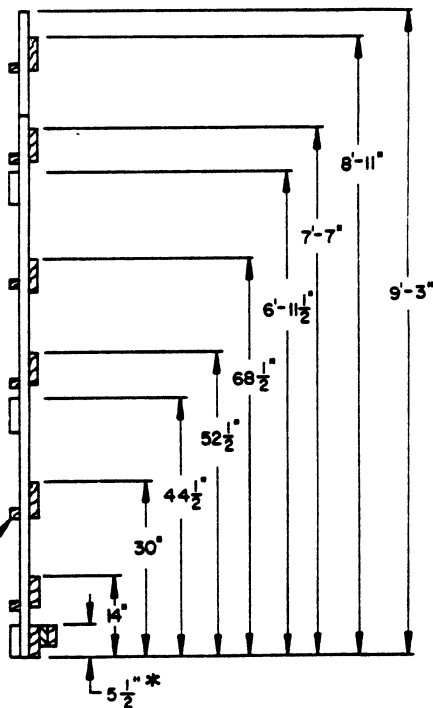

**END VIEW**

\* THE DIMENSION SHOWN IS FOR A GATE WHICH IS TO BE POSITIONED AGAINST THE BELL ENDS OF THE CONTAINERS. THIS DIMENSION WILL BE 6-1/4" FOR THE BASE END OF THE UNITS.

**DETAILS FOR FLAT DUNNAGE METHOD UNIT (DECREASED HEIGHT)**

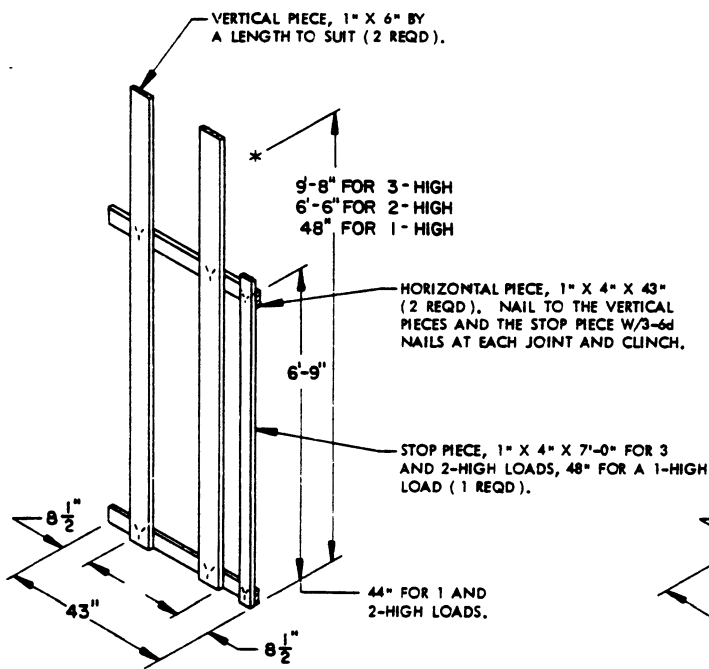

**SEPARATOR GATE G**

RIGHT HAND AND LEFT HAND GATES ARE REQUIRED. A RIGHT HAND GATE IS SHOWN.

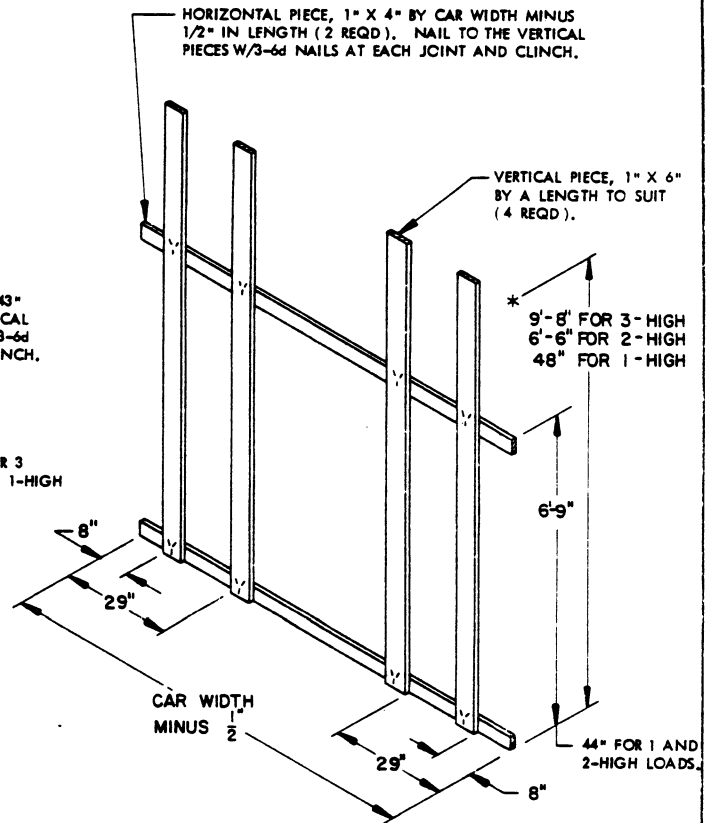

**SEPARATOR GATE H**

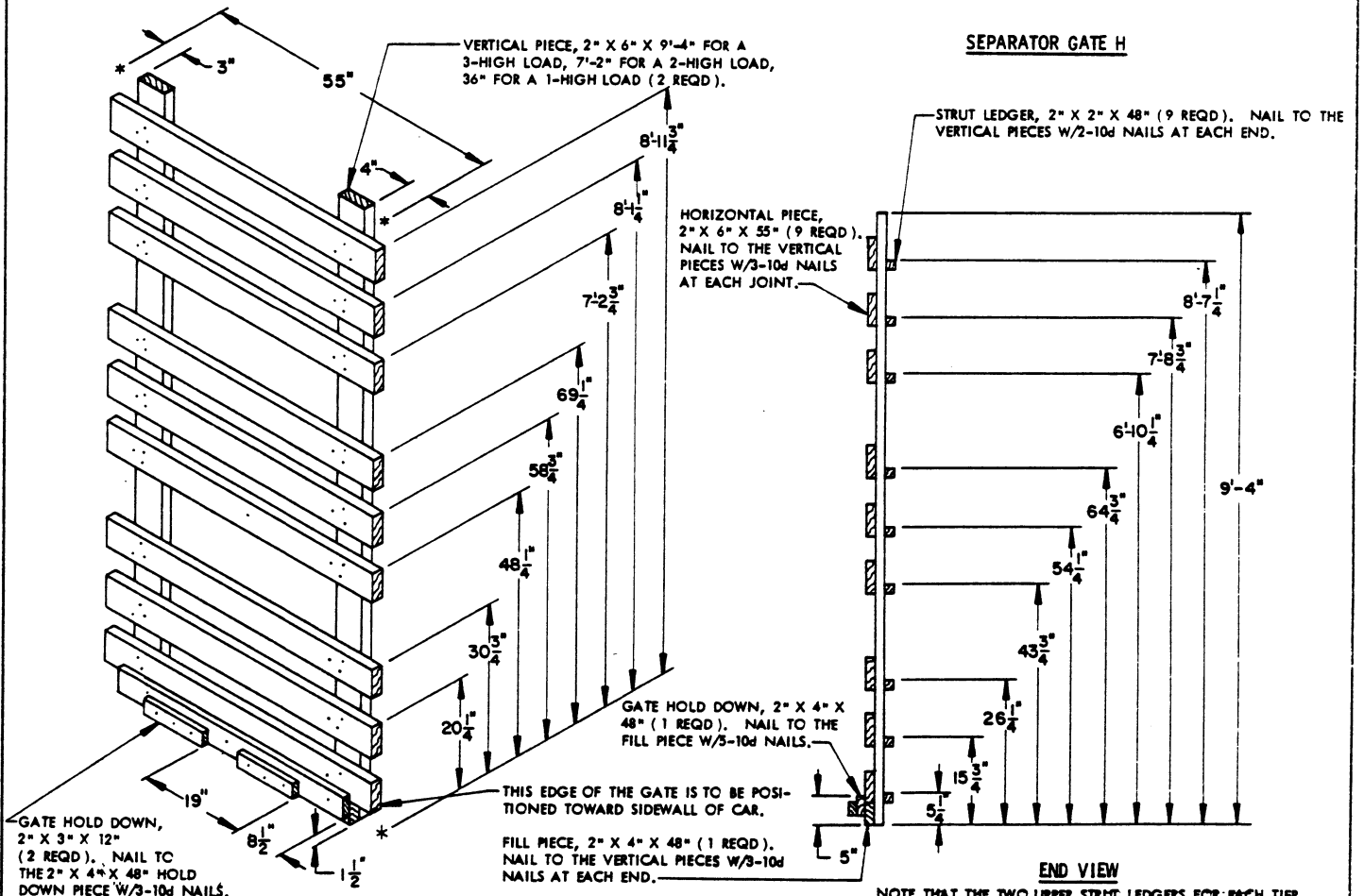

**CENTER GATE O**  
1 RIGHT HAND AND 1 LEFT HAND GATE REQUIRED.

DETAILS FOR FLAT DUNNAGE METHOD UNIT (DECREASED HEIGHT)

NOTE THAT THE TWO UPPER STRUT LEDGERS FOR EACH TIER MAY NEED TO BE APPLIED AFTER THE NEXT LOWER LEVEL STRUTS HAVE BEEN INSTALLED.

HORIZONTAL PIECE, 1" X 6" BY DOOR OPENING WIDTH (6 REQD). NAIL TO THE VERTICAL PIECES W/3-6d NAILS AT EACH END.

DOOR OPENING WIDTH

VERTICAL PIECE, 2" X 3" X 9'-0" (2 REQD). NAIL TO A DOOR POST W/12d NAILS.

9'-0"  
7'-7"  
68 1/2"  
52 1/2"  
30"  
14"

**DOORWAY PROTECTION F**

VERTICAL PIECE, 2" X 6" X 9'-3" FOR A 3-HIGH LOAD, 6'-2" FOR A 2-HIGH LOAD, 36" FOR A 1-HIGH LOAD (4 REQD).

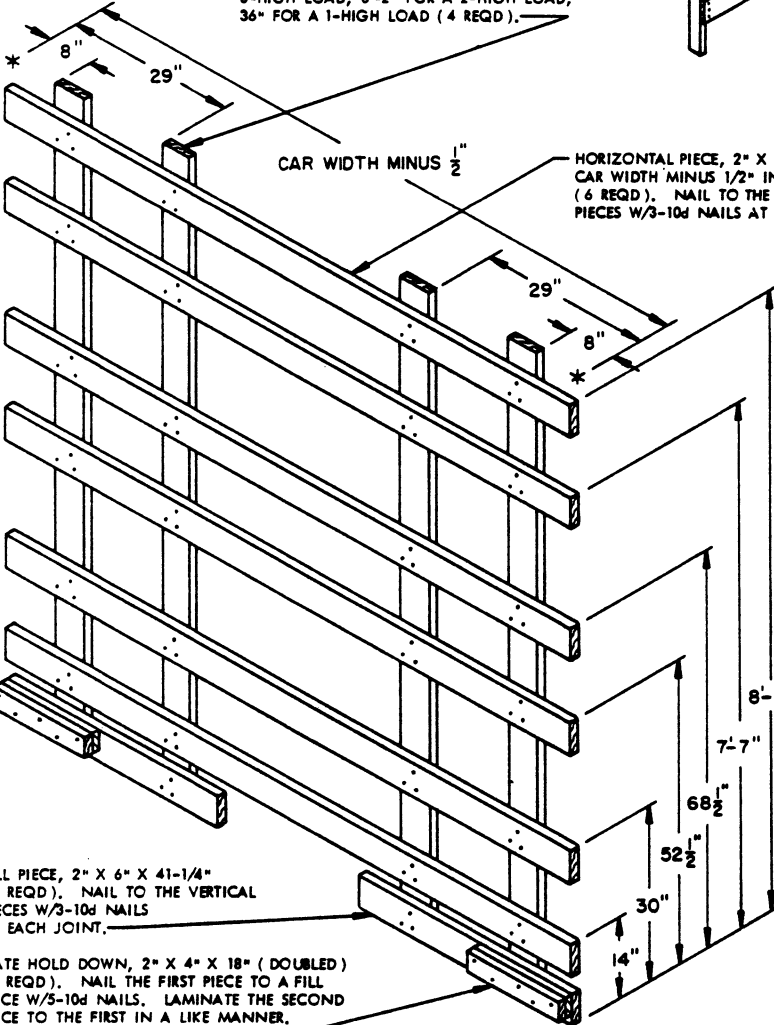

HORIZONTAL PIECE, 2" X 6" BY CAR WIDTH MINUS 1/2" IN LENGTH (6 REQD). NAIL TO THE VERTICAL PIECES W/3-10d NAILS AT EACH JOINT.

STRUT LEDGER, 2" X 2" X CAR WIDTH MINUS 16-1/2" IN LENGTH (6 REQD). NAIL TO THE VERTICAL PIECES W/2-10d NAILS AT EACH JOINT.

FILL PIECE, 2" X 6" X 41-1/4" (2 REQD). NAIL TO THE VERTICAL PIECES W/3-10d NAILS AT EACH JOINT.

GATE HOLD DOWN, 2" X 4" X 18" (DOUBLED) (2 REQD). NAIL THE FIRST PIECE TO A FILL PIECE W/5-10d NAILS. LAMINATE THE SECOND PIECE TO THE FIRST IN A LIKE MANNER. SEE SPECIAL NOTE 11 ON PAGE 51.

**CENTER GATE P**

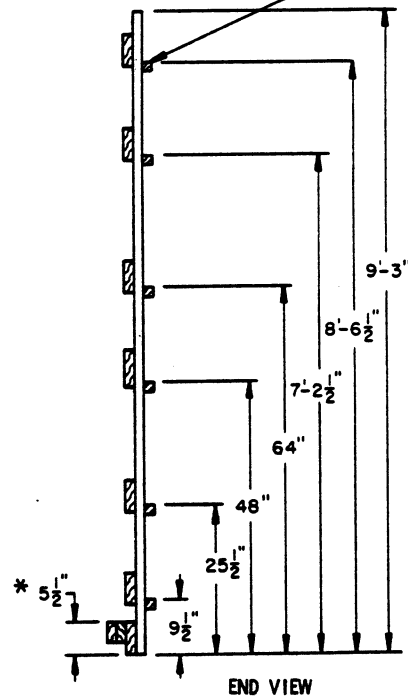

**END VIEW**

\* THE DIMENSION SHOWN IS FOR A GATE WHICH IS TO BE POSITIONED AGAINST THE BELL END OF THE CONTAINERS. THIS DIMENSION WILL BE 6'-1/2" FOR THE BASE END OF UNITS.

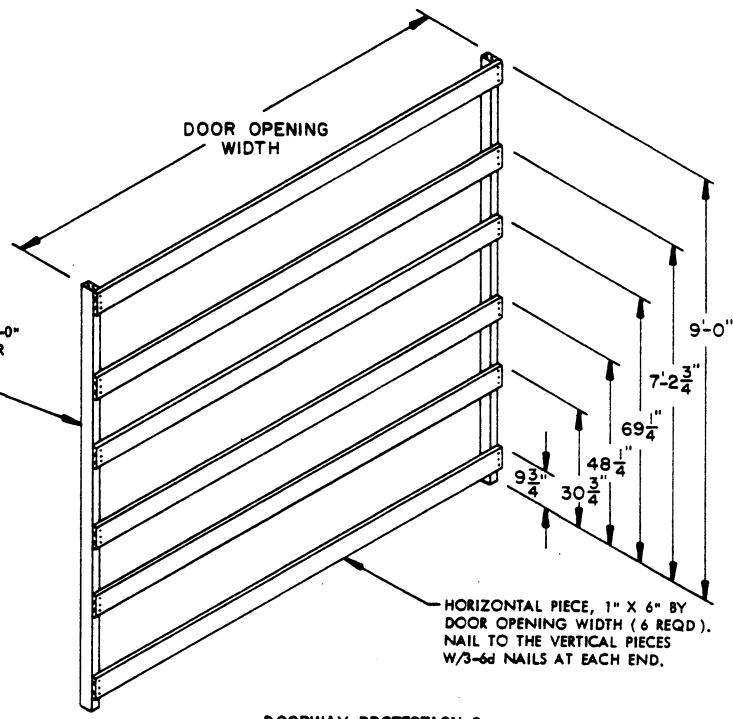

**DOORWAY PROTECTION G**

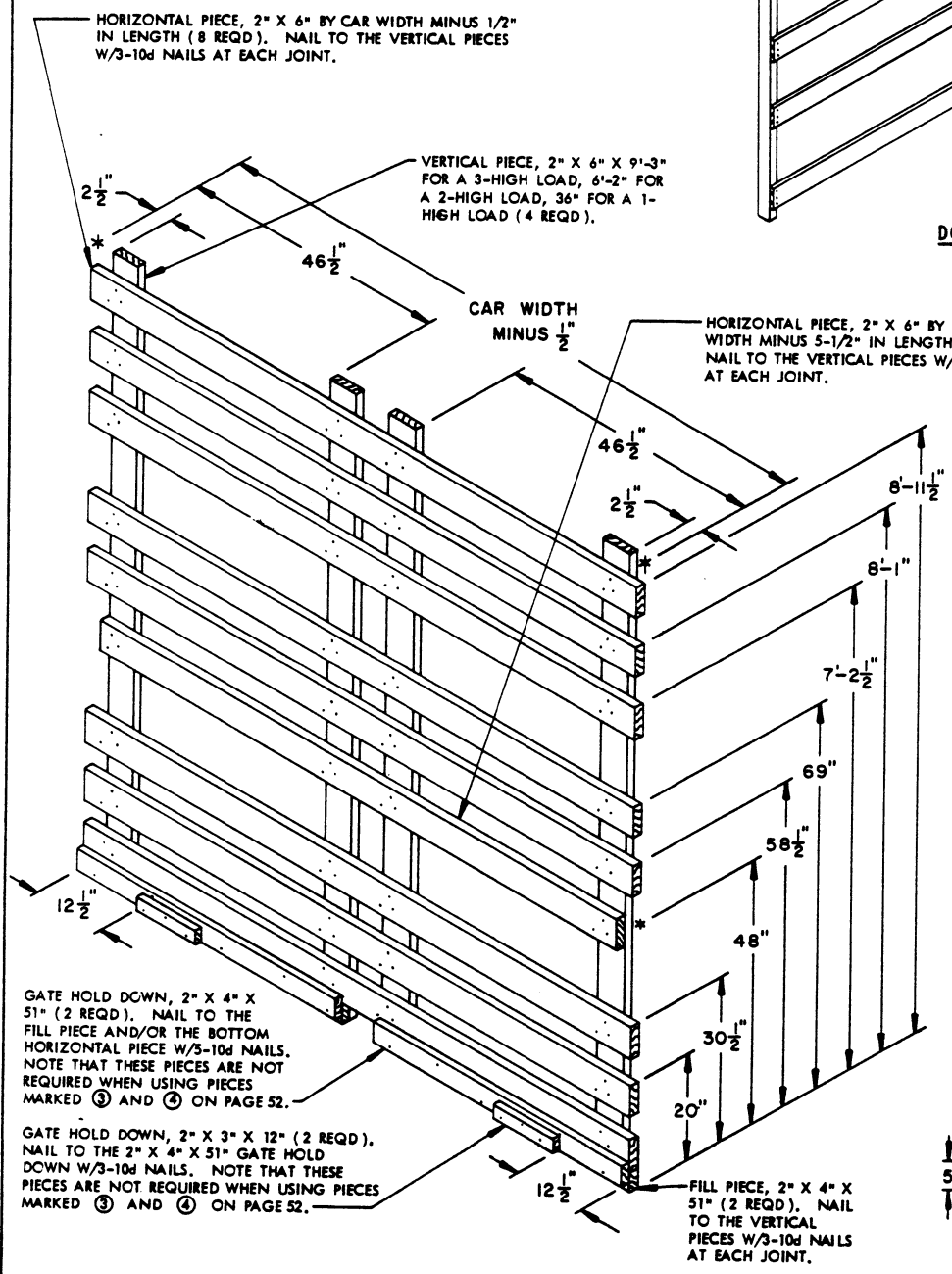

**CENTER GATE Q**

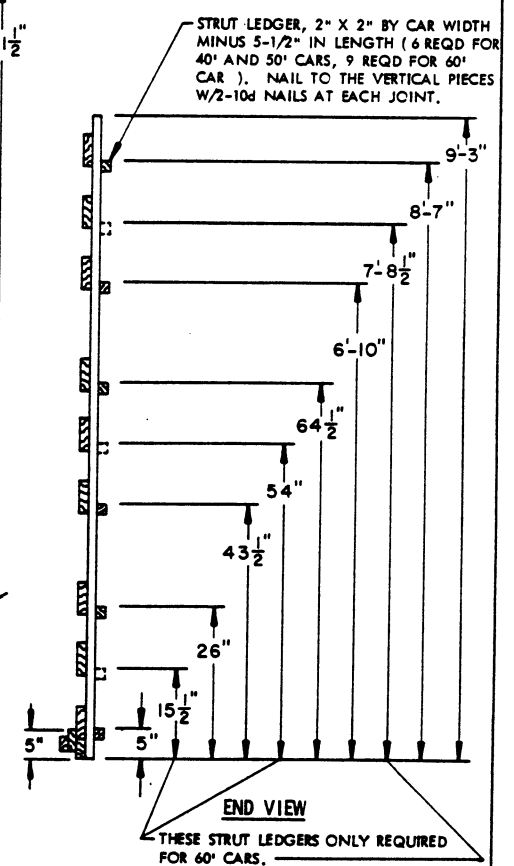

**DETAILS FOR FLAT DUNNAGE METHOD UNIT (DECREASED HEIGHT)**

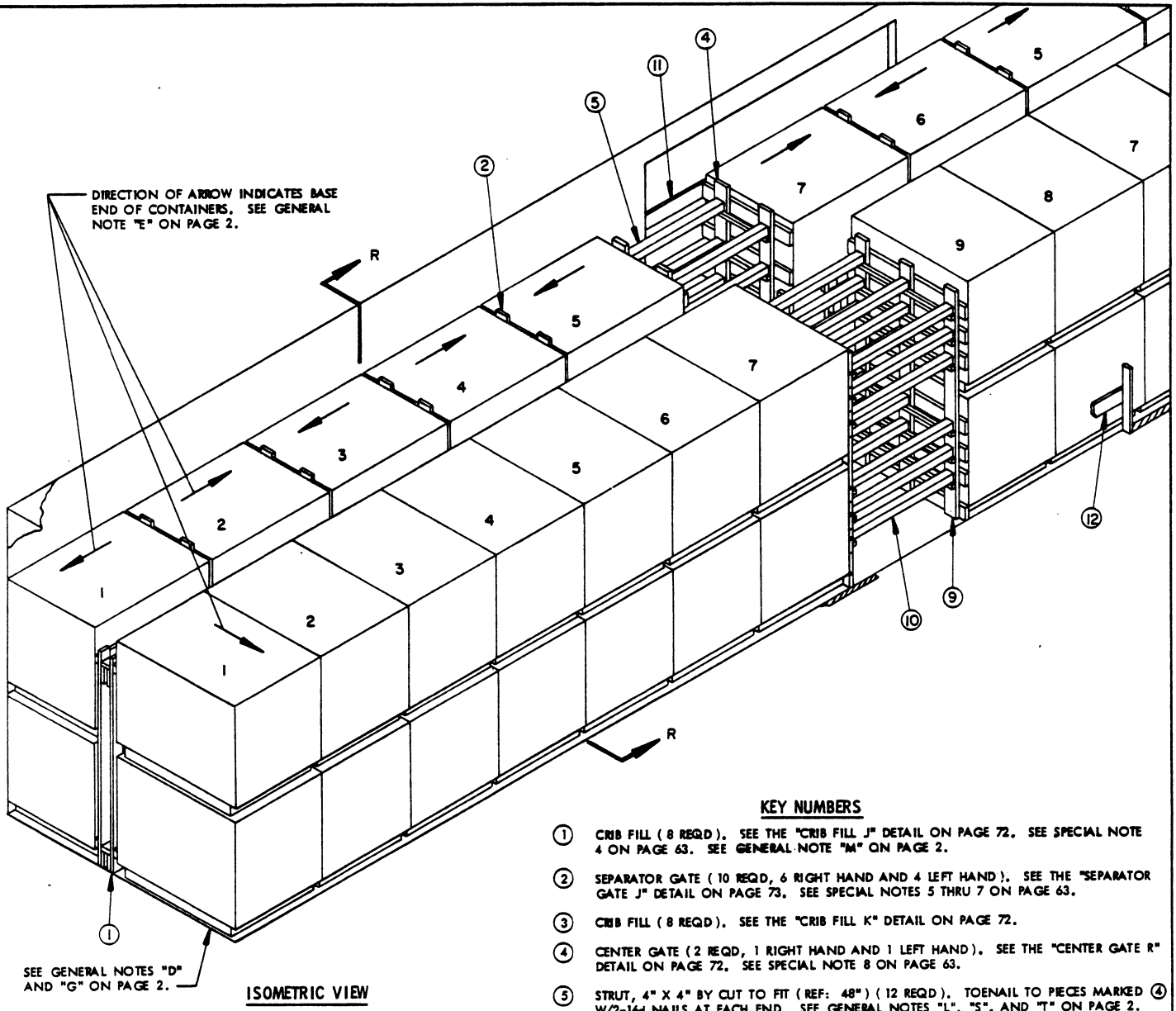

**KEY NUMBERS**

- ① CRIB FILL ( 8 REQD ). SEE THE "CRIB FILL J" DETAIL ON PAGE 72. SEE SPECIAL NOTE 4 ON PAGE 63. SEE GENERAL NOTE "M" ON PAGE 2.
- ② SEPARATOR GATE ( 10 REQD, 6 RIGHT HAND AND 4 LEFT HAND ). SEE THE "SEPARATOR GATE J" DETAIL ON PAGE 73. SEE SPECIAL NOTES 5 THRU 7 ON PAGE 63.
- ③ CRIB FILL ( 8 REQD ). SEE THE "CRIB FILL K" DETAIL ON PAGE 72.
- ④ CENTER GATE ( 2 REQD, 1 RIGHT HAND AND 1 LEFT HAND ). SEE THE "CENTER GATE R" DETAIL ON PAGE 72. SEE SPECIAL NOTE 8 ON PAGE 63.
- ⑤ STRUT, 4" X 4" BY CUT TO FIT ( REF: 48" ) ( 12 REQD ). TOENAIL TO PIECES MARKED ④ W/2-16d NAILS AT EACH END. SEE GENERAL NOTES "L", "S", AND "T" ON PAGE 2.
- ⑥ STRUT, 2" X 4" BY CUT TO FIT ( REF: 48" ) ( 2 REQD ). TOENAIL TO THE STOP PIECES OF PIECES MARKED ④ W/2-12d NAILS AT EACH END. SEE THE "PARTIAL PLAN VIEW" ON PAGE 63.
- ⑦ SIDE BLOCKING FOR CENTER GATE "R", 2" X 4" X 18" ( DOUBLED ) ( 1 REQD ). NAIL THE FIRST PIECE TO THE CAR FLOOR W/4-16d NAILS. NAIL SECOND PIECE TO THE FIRST IN A LIKE MANNER. SEE THE "PARTIAL PLAN VIEW" ON PAGE 63.
- ⑧ CRIB FILL RETAINER, 2" X 4" BY A LENGTH TO SUIT ( REF: 72" ) ( 2 REQD ). POSITION TO SPAN THE STRUTS OF LONGITUDINALLY ADJACENT CRIB FILL "K" ASSEMBLIES AND NAIL TO EACH STRUT W/3-10d NAILS. SEE THE "PARTIAL PLAN VIEW" ON PAGE 63.
- ⑨ CENTER GATE ( 2 REQD ). SEE THE "CENTER GATE S" DETAIL ON PAGE 73.
- ⑩ STRUT, 4" X 4" BY CUT TO FIT ( REF: 48" ) ( 18 REQD ). TOENAIL TO PIECES MARKED ⑨ W/2-16d NAILS AT EACH END.
- ⑪ DOORWAY PROTECTION ( 1 REQD ). SEE THE "DOORWAY PROTECTION H" DETAIL ON PAGE 74. NAIL TO THE DOOR POSTS W/12d NAILS. SEE SPECIAL NOTE 9 ON PAGE 63.
- ⑫ DOORWAY PROTECTION ( 1 REQD ). SEE THE "DOORWAY PROTECTION J" DETAIL ON PAGE 75. NAIL TO THE DOOR POSTS W/12d NAILS.

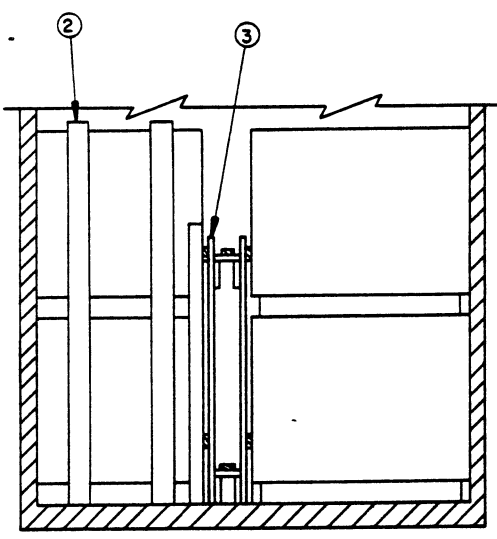

ROUTED DUNNAGE METHOD UNIT ( BASIC HEIGHT )  
 56-UNIT LOAD IN A 60'-8" LONG BY 9'-2" WIDE CONVENTIONAL BOX CAR

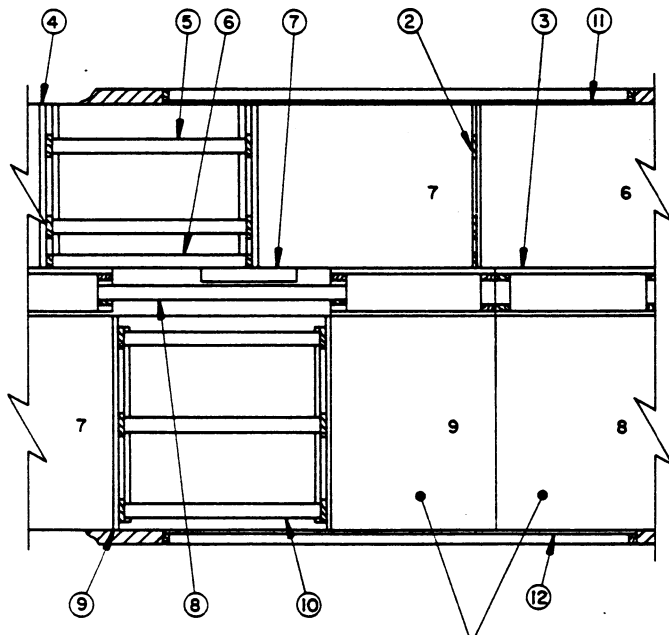

**PARTIAL PLAN VIEW**

IF THE CAR BEING LOADED IS EQUIPPED WITH PLUG TYPE DOORS, SEE SPECIAL NOTE 9 AT RIGHT.

(SPECIAL NOTES CONTINUED)

10. THE DEPICTED LOAD CAN BE REDUCED TO SUIT THE QUANTITY TO BE SHIPPED. A 2-TIER LOAD CAN BE REDUCED BY ONE OR MORE PALLET UNITS BY EMPLOYING THE PROCEDURES ON PAGE 96. FOUR (4) UNITS CAN BE OMITTED FROM A 2-TIER LOAD BY LEAVING OUT THE LENGTHWISE STACK NO. 7 AND THE CROSSWISE STACK NO. 9. NOTE THAT STRUT BRACING WILL THEN BE REQUIRED. OR, THE ENTIRE TOP TIER CAN BE OMITTED. A PARTIAL 1-TIER LOAD CAN BE SHIPPED IN ONE OR BOTH ENDS OF A CAR BY USING KNEE BRACES AS SHOWN ON PAGES 112 AND 113.
11. IF PALLETIZED UNITS WHICH DO NOT CONTAIN A FULL QUANTITY OF CONTAINERS ARE TO BE TRANSPORTED, REFER TO PAGE 117 FOR SHIPPING GUIDANCE. FOR LENGTHWISE UNITS AND PAGES 118 AND 120 FOR CROSSWISE UNITS.
12. FOR SHIPMENT OF ONE OR MORE LEFTOVER CONTAINERS, SEE THE "PROCEDURES FOR SHIPMENT OF LEFTOVER CONTAINERS" ON PAGE 119 FOR GUIDANCE.

**SPECIAL NOTES:**

1. A 60'-8" LONG BY 9'-2" WIDE WOOD-LINED CONVENTIONAL TYPE BOXCAR EQUIPPED WITH 10'-0" WIDE DOOR OPENINGS IS SHOWN. CARS OF OTHER DIMENSIONS AND CARS HAVING WIDER OR NARROWER DOOR OPENINGS CAN BE USED. SEE GENERAL NOTE "D" ON PAGE 2 AND SPECIAL NOTE 3 BELOW.
2. THE PALLET UNIT SHOWN IN THE TYPICAL LOAD ON PAGE 62 IS THE ROUTED DUNNAGE METHOD UNIT ( BASIC HEIGHT ). A MAXIMUM OF FORTY-SIX (46) OF THESE UNITS, FOR AN APPROXIMATE LADING WEIGHT OF 97,612 POUNDS, CAN BE PLACED IN A 50'-6" LONG CAR WHEN USING THE DEPICTED PROCEDURES THIRTY-SIX (36) UNITS, FOR A LADING WEIGHT OF 76,392 POUNDS, CAN BE OUTLOADED IN A 40'-6" LONG CAR.
3. THE DEPICTED LOAD PATTERN IS ADEQUATE FOR CARS HAVING DOOR OPENINGS AS NARROW AS 7'-0". IF THE CAR TO BE LOADED HAS DOOR OPENINGS LESS THAN 7'-0" WIDE AND NOT OF SUFFICIENT HEIGHT TO ALLOW PERSONNEL TO EXIT OVER THE TOP OF THE LOAD, THE LENGTHWISE UNITS SHOULD BE LOADED SIX (6) STACKS LONG IN EACH END OF THE CAR AND THE CROSSWISE UNITS SHOULD BE LOADED EIGHT (8) STACKS LONG IN EACH END. AN ADDITIONAL PIECE MARKED ⑦ WILL BE REQUIRED; THE BALANCE OF THE DUNNAGE WILL NOT CHANGE.
4. THE "HIGH" CRIB, SHOWN AS PIECE MARKED ①, MUST BE INSTALLED IN EACH END OF THE LOAD. FOUR (4) ASSEMBLIES ARE REQUIRED IN EACH END OF A LOAD REGARDLESS OF THE CAR LENGTH.
5. THE SEPARATOR GATES, SHOWN AS PIECES MARKED ② IN THE LOAD ON PAGE 62, ARE DESIGNATED "RIGHT HAND" AND "LEFT HAND" TO FACILITATE POSITIONING OF THE PALLET UNITS AS LOADING PROGRESSES. WHEN LOADING THE CAR, POSITION A PALLET UNIT STACK AGAINST THE END WALL THEN POSITION A SEPARATOR GATE SO THE 1" X 4" TIE PIECES ARE LOCATED UNDER THE "OVERHANG" OF THE PALLET UNITS IN THE FIRST STACK. REPEAT THIS PROCEDURE FOR THE REMAINING STACKS.
6. ALL SEPARATOR GATES, PIECES MARKED ②, WHICH ARE WITHIN THE DOORWAY AREA OF A CAR EQUIPPED WITH CONVENTIONAL SLIDING DOORS MUST BE WIRE TIED TO THE ADJACENT CRIB FILL TO PREVENT DISPLACEMENT. ENCIRCLE THE STOP PIECE OF THE SEPARATOR GATE AND THE UPPER HORIZONTAL PIECE OF THE CRIB FILL WITH NO. 14 GAGE WIRE AND TWIST TAUT.
7. SEPARATOR GATES MAY BE FORMED FROM 3/8" OR THICKER PLYWOOD IN LIEU OF DIMENSIONAL LUMBER, IF DESIRED. CONSTRUCT EACH GATE 42" WIDE BY 8'-0" LONG.
8. CENTER GATES "R" AND "S" MAY BE PARTIALLY FORMED FROM 1/2" OR THICKER PLYWOOD, IF DESIRED. PLYWOOD MAY BE USED IN LIEU OF THE 2" X 6" HORIZONTAL PIECES. SEE THE "PLYWOOD CENTER GATE ALTERNATIVE" DETAIL ON PAGE 123 FOR GUIDANCE.
9. DOORWAY PROTECTION IS REQUIRED FOR ALL PALLET UNIT STACKS WHICH ARE COMPLETELY WITHIN THE DOORWAY AREA OR WHICH EXTEND INTO THE DOORWAY AREA BY ONE-HALF OR MORE OF THE STACK WIDTH OR LENGTH. THE WOODEN GATE TYPE OF DOORWAY PROTECTION, SHOWN AS PIECES MARKED ⑩ AND ⑪ IN THE LOAD ON PAGE 62, IS APPLICABLE FOR BOXCARS EQUIPPED WITH CONVENTIONAL SLIDING DOORS AND NAILABLE DOOR POSTS. REFER TO PAGES 126 THRU 128 FOR ALTERNATIVE DOORWAY PROTECTION FOR CARS EQUIPPED WITH CONVENTIONAL SLIDING DOORS. IF THE CAR BEING LOADED IS EQUIPPED WITH PLUG TYPE DOORS, NAILED FLOORLINE BLOCKING AND LOAD-BUNDLING STRAPS MUST BE USED. SEE THE "ALTERNATIVE DOORWAY PROTECTION E" AND "ALTERNATIVE DOORWAY PROTECTION F" DETAILS ON PAGE 128 FOR GUIDANCE; A COMBINATION OF THE TWO METHODS MUST BE USED. NAILED SIDE BLOCKING WILL BE USED UNDER THE CRIB FILL SHOWN IN THE DOORWAY AREA OF THE LOAD. POSITION DOUBLED 2" X 4" X 8'-0" PIECES AGAINST THE LENGTHWISE STACKS NUMBERED 6 AND 7, AND PRE-POSITION DOUBLED 2" X 4" X 7'-0" PIECES (APPROXIMATELY 52" FROM THE NEAR SIDE CAR WALL) SO AS TO BE AGAINST THE CROSSWISE STACKS NUMBERED 8 AND 9. THESE PIECES WILL BE USED IN LIEU OF THE 40" AND 48" LONG PIECES SHOWN BY THE ALTERNATIVE DETAILS. A SPACER ASSEMBLY, AS SHOWN IN THE "ALTERNATIVE DOORWAY PROTECTION F" DETAIL MUST BE MODIFIED FOR USE BY CHANGING THE END WHICH EXTENDS OVER THE CROSSWISE CONTAINERS TO BE LIKE THE NEAR END OF THE STRAPPING BOARD SHOWN IN THE "ALTERNATIVE DOORWAY PROTECTION E" DETAIL. A 2" X 4" X 40" DOUBLED BATTEN AS SHOWN IN THAT VIEW IS ALSO REQUIRED. NOTE THAT THE VERTICAL PIECES AND BOTTOM SUPPORT PIECES OF THE CRIB FILL, PIECES MARKED ③, MUST HAVE THREE INCHES (3") CUT OFF THE BOTTOM END OF ONE SIDE SO THE CRIB WILL REST EVENLY ON THE NAILED SIDE BLOCKING WHICH IS ADJACENT TO THE LENGTHWISE UNITS. ALSO NOTE THAT THE CENTER GATE "R" WHICH IS IN THE DOOR OPENING MUST BE WIRE TIED TO PIECE MARKED ⑥ TO PREVENT DISPLACEMENT.

(CONTINUED AT LEFT)

**LOAD AS SHOWN**

ITEM	QUANTITY	WEIGHT ( APPROX )
PALLET UNIT	56	118,832 LBS
DUNNAGE		2,263 LBS
<b>TOTAL WEIGHT</b>		<b>121,095 LBS</b>

BILL OF MATERIAL		
LUMBER	LINEAR FEET	BOARD FEET
1" X 4"	144	48
1" X 6"	245	123
2" X 2"	76	26
2" X 3"	39	20
2" X 4"	810	540
2" X 6"	195	195
4" X 4"	125	167
NAILS	NO. REQD	POUNDS
6d (2")	228	1-1/2
10d (3")	1280	19-3/4
12d (3-1/4")	38	3/4
16d (3-1/2")	128	3
WIRE, NO. 14 GAGE	3' REQD	NIL

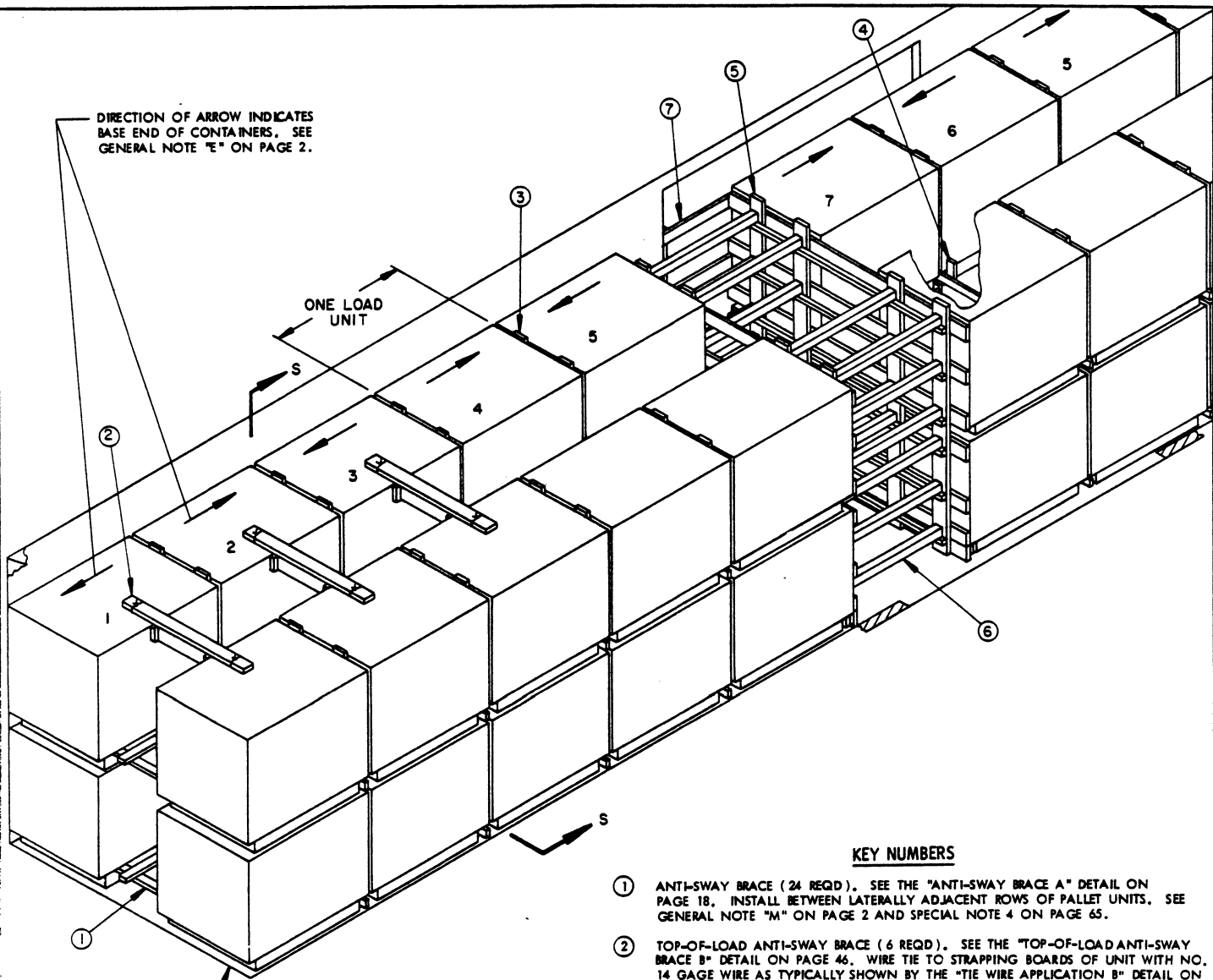

DIRECTION OF ARROW INDICATES  
BASE END OF CONTAINERS. SEE  
GENERAL NOTE "E" ON PAGE 2.

ONE LOAD  
UNIT

SEE GENERAL NOTES  
"D" AND "G" ON PAGE 2.

**ISOMETRIC VIEW**

**KEY NUMBERS**

- ① ANTI-SWAY BRACE (24 REQD). SEE THE "ANTI-SWAY BRACE A" DETAIL ON PAGE 18. INSTALL BETWEEN LATERALLY ADJACENT ROWS OF PALLET UNITS. SEE GENERAL NOTE "M" ON PAGE 2 AND SPECIAL NOTE 4 ON PAGE 65.
- ② TOP-OF-LOAD ANTI-SWAY BRACE (6 REQD). SEE THE "TOP-OF-LOAD ANTI-SWAY BRACE B" DETAIL ON PAGE 46. WIRE TIE TO STRAPPING BOARDS OF UNIT WITH NO. 14 GAGE WIRE AS TYPICALLY SHOWN BY THE "TIE WIRE APPLICATION B" DETAIL ON PAGE 122. SEE SPECIAL NOTE 5 ON PAGE 65.
- ③ SEPARATOR GATE (10 REQD). SEE THE "SEPARATOR GATE K" DETAIL ON PAGE 73. POSITION WITH THE HORIZONTAL PIECES AGAINST THE ALREADY-LOADED UNITS. SEE SPECIAL NOTES 6 AND 8 ON PAGE 65.
- ④ STOP PIECE, 1" X 4" X 60" (2 REQD). INSTALL ON THE SIDE OPPOSITE THE VERTICAL PIECES OF THE SEPARATOR GATE, PIECE MARKED ③, WHICH IS IN THE DOORWAY AREA. POSITION IN CONTACT WITH ADJACENT PALLET UNITS AND NAIL TO THE HORIZONTAL PIECES W/3-6d NAILS AT EACH JOINT AND CLINCH. SEE SPECIAL NOTE 7 ON PAGE 65.
- ⑤ CENTER GATE (2 REQD). SEE THE "CENTER GATE T" DETAIL ON PAGE 74. SEE SPECIAL NOTES 9 AND 10 ON PAGE 65.
- ⑥ STRUT, 4" X 4" BY CUT TO FIT (REF: 48") (24 REQD). TOENAIL TO PIECES MARKED ⑤ W/2-16d NAILS AT EACH END. SEE GENERAL NOTES "L", "S", AND "T" ON PAGE 2.
- ⑦ DOORWAY PROTECTION (2 REQD). SEE "DOORWAY PROTECTION H" DETAIL ON PAGE 74. NAIL TO DOOR POSTS W/12d NAILS. SEE SPECIAL NOTE 12 ON PAGE 65.

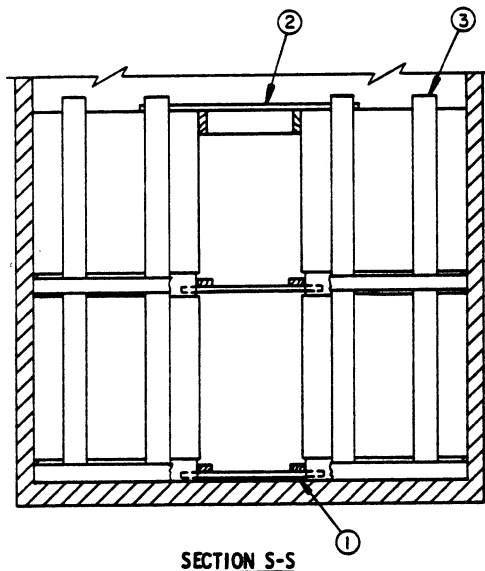

**SECTION S-S**

**ROUTED DUNNAGE METHOD UNIT (BASIC HEIGHT)  
48-UNIT LOAD IN A 60'-8" LONG BY 9'-2" WIDE CONVENTIONAL BOX CAR**



( SPECIAL NOTES CONTINUED )

13. IF THE ALTERNATIVE DOORWAY PROTECTION "F" PROCEDURES SHOWN ON PAGE 128 ARE USED IN LIEU OF THE WOODEN DOORWAY PROTECTION, PIECES MARKED ⑦, THE CENTER GATES MUST BE RESTRAINED FROM LATERAL MOVEMENT. THIS CAN BE ACCOMPLISHED BY NAILING TO THE CAR FLOOR A DOUBLED 2" X 4" X 18" PIECE POSITIONED LONGITUDINALLY SO AS TO BE CENTERED AGAINST THE FILL PIECE OF A CENTER GATE. TWO (2) PIECES WILL BE REQUIRED FOR EACH CENTER GATE WHICH IS IN THE DOOR OPENING OR WITHIN SIX INCHES (6") OF BEING IN THE DOOR OPENING.
14. THE DEPICTED LOAD CAN BE REDUCED TO SUIT THE QUANTITY TO BE SHIPPED. A 2-TIER LOAD CAN BE REDUCED BY A MULTIPLE OF FOUR (4) PALLET UNITS OR A 1-TIER LOAD CAN BE REDUCED BY A MULTIPLE OF TWO (2) UNITS BY OMITTING ONE OR MORE LOAD UNITS FROM THE CENTER PORTION OF THE LOAD. OR, THE ENTIRE TOP TIER CAN BE OMITTED. FOR OTHER METHODS OF REDUCING A LOAD, AND FOR TYPICAL LCL PROCEDURES, REFER TO PAGES 92 THRU 120 FOR GUIDANCE.
15. IF PALLETIZED UNITS WHICH DO NOT CONTAIN A FULL QUANTITY OF CONTAINERS ARE TO BE TRANSPORTED, REFER TO PAGE 117 FOR SHIPPING GUIDANCE.
16. FOR SHIPMENT OF ONE OR MORE LEFTOVER CONTAINERS, SEE THE "PROCEDURES FOR SHIPMENT OF LEFTOVER CONTAINERS" ON PAGE 119 FOR GUIDANCE.

SPECIAL NOTES:

1. A 60'-8" LONG BY 9'-2" WIDE WOOD-LINED CONVENTIONAL TYPE BOXCAR EQUIPPED WITH 10'-0" WIDE DOOR OPENINGS IS SHOWN. CARS OF OTHER DIMENSIONS AND CARS HAVING WIDER OR NARROWER DOOR OPENINGS CAN BE USED. SEE GENERAL NOTE "D" ON PAGE 2 AND SPECIAL NOTE 3 BELOW.
2. THE PALLETIZED UNIT SHOWN IN THE TYPICAL LOAD ON PAGE 64 IS THE ROUTED DUNNAGE METHOD UNIT ( BASIC HEIGHT ). A MAXIMUM OF FORTY (40) OF THESE UNITS, FOR AN APPROXIMATE LADING WEIGHT OF 84,880 POUNDS, CAN BE PLACED IN A 50'-6" LONG CAR WHEN USING THE DEPICTED PROCEDURES; THIRTY-TWO (32) UNITS, FOR AN APPROXIMATE WEIGHT OF 67,904 POUNDS, CAN BE OUTLOADED IN A 40'-6" LONG CAR.
3. THE DEPICTED LOADING PATTERN IS ADEQUATE FOR CARS HAVING DOOR OPENINGS 8' THRU 10', OR WIDER. IF THE CAR TO BE LOADED HAS DOOR OPENINGS LESS THAN 8'-0" WIDE AND NOT OF SUFFICIENT HEIGHT TO ALLOW PERSONNEL TO EXIT THE CAR OVER THE TOP OF THE LOAD, THE PALLETS SHOULD BE POSITIONED SO THERE ARE SIX (6) LOAD UNITS IN EACH END. NOTE THAT ALTHOUGH CARS HAVING DOOR OPENINGS AS NARROW AS 6'-0" WIDE CAN BE USED FOR FULL LOADS, LOADING IS PROGRESSIVELY MORE DIFFICULT AS THE WIDTH OF THE DOOR OPENING DECREASES.
4. IF THE "ALTERNATIVE DOORWAY PROTECTION F" PROCEDURES AS SHOWN ON PAGE 128 ARE USED IN LIEU OF THE WOODEN DOOR GATE TYPE PROTECTION, PIECE MARKED ⑦, NAILED FLOORLINE BLOCKING MUST BE USED IN LIEU OF EACH LOWER ANTI-SWAY BRACE IN THE DOORWAY AREA. NAILED BLOCKING IS REQUIRED FOR ALL PALLET STACKS WHICH ARE COMPLETELY WITHIN THE DOORWAY AREA OR WHICH EXTEND INTO THE DOORWAY AREA BY ONE-HALF OR MORE OF THE STACK WIDTH ON EITHER SIDE OF THE CAR.
5. TOP-OF-LOAD ANTI-SWAY BRACES, SHOWN AS PIECES MARKED ② IN THE LOAD ON PAGE 64, MUST BE INSTALLED IN EACH END OF THE CAR AND WIRE TIED TO A STRAPPING BOARD WITH NO. 14 GAGE WIRE AS SHOWN. THREE (3) BRACES ARE REQUIRED IN EACH END OF A LOAD REGARDLESS OF THE CAR LENGTH.
6. TO FACILITATE POSITIONING OF THE PALLET UNITS AS LOADING PROGRESSES, WHEN LOADING THE BOXCAR, POSITION PALLET UNIT STACKS AGAINST THE END WALL, THEN POSITION A SEPARATOR GATE, SHOWN AS PIECE MARKED ③, SO THE 1" X 4" TIE PIECES ARE LOCATED UNDER THE "OVERHANG" OF THE PALLET UNITS. REPEAT THIS PROCEDURE FOR THE REMAINING STACKS.
7. SEPARATOR GATES IN THE DOORWAY MUST BE PREVENTED FROM SHIFTING INTO A DOOR OPENING BY THE APPLICATION OF THE STOP PIECES, PIECES MARKED ④. IN CARS EQUIPPED WITH STAGGERED DOORS, STOP PIECES MAY BE REQUIRED ON UP TO FOUR SEPARATOR GATES.
8. SEPARATOR GATES MAY BE FORMED FROM 3/8" OR THICKER PLYWOOD IN LIEU OF DIMENSIONAL LUMBER, IF DESIRED. SEE THE "ALTERNATIVE SEPARATOR GATE" DETAIL ON PAGE 122 FOR CONSTRUCTION GUIDANCE.
9. CENTER GATE "T" MAY BE PARTIALLY FORMED FROM 1/2" OR THICKER PLYWOOD, IF DESIRED. PLYWOOD MAY BE USED IN LIEU OF THE 2" X 6" HORIZONTAL PIECES. SEE THE "PLYWOOD CENTER GATE ALTERNATIVE" DETAIL ON PAGE 123 FOR GUIDANCE.
10. FOR EASE OF HANDLING, SPLIT CENTER GATES, WHICH ARE NOT DEPENDENT UPON THE WIDTH OF THE CAR, MAY BE USED AS AN ALTERNATIVE TO THE CAR-WIDTH GATES. IN LIEU OF EACH "CENTER GATE T", SHOWN AS PIECE MARKED ③ IN THE LOAD ON PAGE 64, INSTALL TWO (2) "CENTER GATES R" AS SHOWN ON PAGE 72. AFTER THE SPLIT GATES AND STRUTS HAVE BEEN INSTALLED, THE SPLIT GATES MUST BE TIED TOGETHER AS DEPICTED BY THE "TIE PIECE APPLICATION" DETAIL ON PAGE 123. OMIT THE STOP PIECES FROM "CENTER GATES R".
11. DOOR SPANNER TYPE GATE HOLD DOWN MAY BE USED IN LIEU OF THE DOUBLED 2" X 4" MATERIAL NAILED TO CENTER GATE "T", PROVIDING THE CAR BEING LOADED HAS NAILED SIDEWALLS. SEE THE DETAILS ON PAGE 125 FOR GUIDANCE.
12. DOORWAY PROTECTION IS REQUIRED FOR ALL PALLET UNIT STACKS WHICH ARE COMPLETELY WITHIN THE DOORWAY AREA OR WHICH EXTEND INTO THE DOORWAY AREA BY ONE-HALF OR MORE OF THE STACK WIDTH. THE WOODEN GATE TYPE OF DOORWAY PROTECTION, SHOWN AS PIECE MARKED ⑦ IN THE LOAD ON PAGE 64, IS APPLICABLE FOR BOXCARS EQUIPPED WITH CONVENTIONAL SLIDING DOORS AND NAILED DOOR POSTS. REFER TO PAGES 126 THRU 128 FOR ALTERNATIVE DOORWAY PROTECTION FOR CARS EQUIPPED WITH CONVENTIONAL SLIDING DOORS. IF THE CAR BEING LOADED IS EQUIPPED WITH PLUG TYPE DOORS, NAILED FLOORLINE BLOCKING AND LOAD BUNDLING STRAPS MUST BE USED. SEE THE "ALTERNATIVE DOORWAY PROTECTION F" DETAIL ON PAGE 128 FOR GUIDANCE.

( CONTINUED AT LEFT )

LOAD AS SHOWN

ITEM	QUANTITY	WEIGHT ( APPROX )
PALLET UNIT-----	48-----	101,856 LBS
DUNNAGE-----		1,827 LBS
TOTAL WEIGHT -----		103,683 LBS

BILL OF MATERIAL		
LUMBER	LINEAR FEET	BOARD FEET
1" X 4"	193	65
1" X 6"	410	205
2" X 2"	94	32
2" X 3"	32	16
2" X 4"	357	238
2" X 6"	215	215
4" X 4"	100	134
NAILS	NO. REQD	POUNDS
6d ( 2" )	290	1-3/4
10d ( 3" )	676	10-1/2
12d ( 3-1/4" )	32	3/4
16d ( 3-1/2" )	96	2-1/4
WIRE, NO. 14 GAGE -----60' REQD -----1 LB		

ROUTED DUNNAGE METHOD UNIT ( BASIC HEIGHT )  
48-UNIT LOAD IN A 60'-8" LONG BY 9'-2" WIDE CONVENTIONAL BOX CAR

SEE SPECIAL NOTE 3 ON PAGE 67.

DIRECTION OF ARROW INDICATES BASE END OF CONTAINERS. SEE GENERAL NOTE "E" ON PAGE 2.

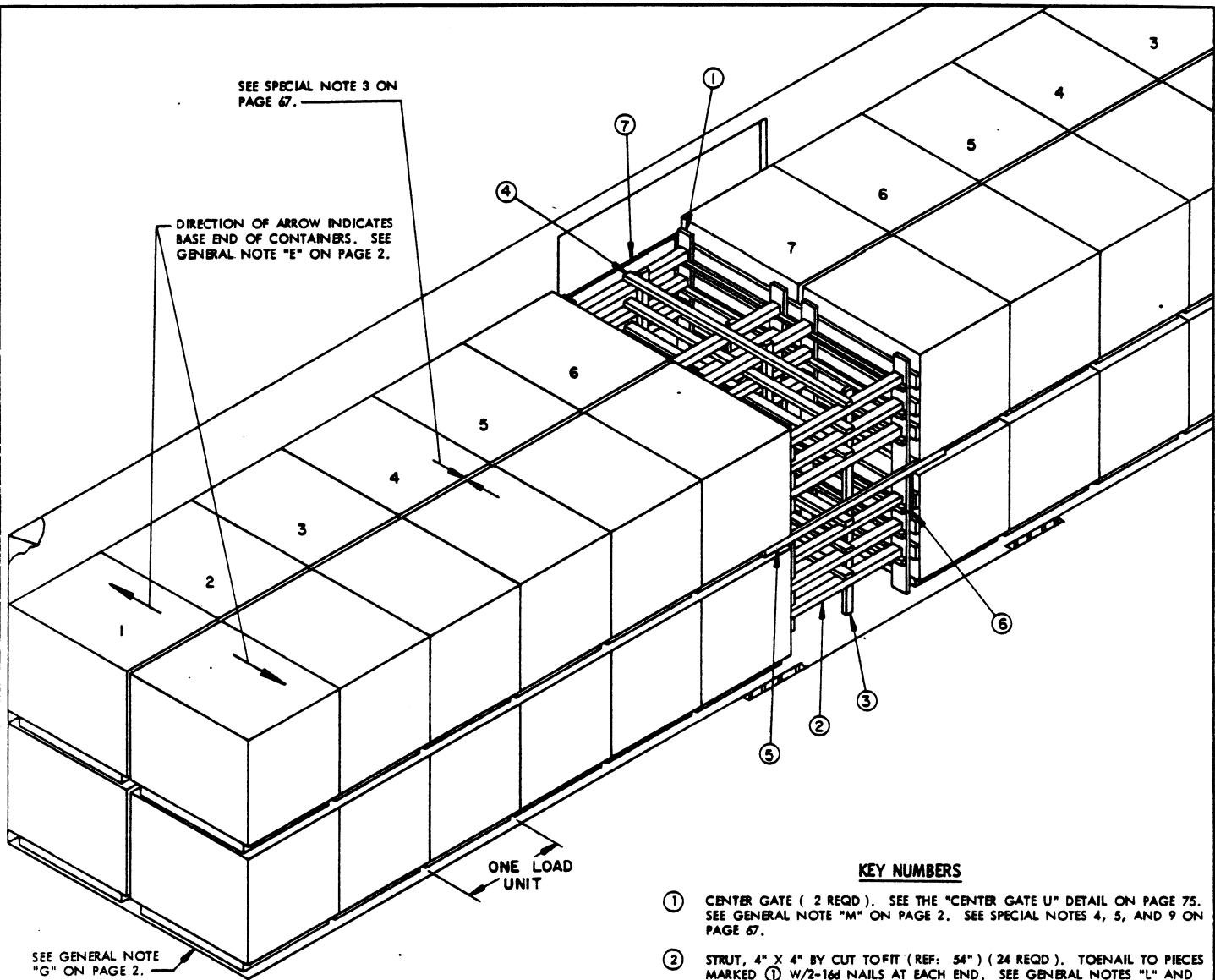

**ISOMETRIC VIEW**

**KEY NUMBERS**

- ① CENTER GATE ( 2 REQD ). SEE THE "CENTER GATE U" DETAIL ON PAGE 75. SEE GENERAL NOTE "M" ON PAGE 2. SEE SPECIAL NOTES 4, 5, AND 9 ON PAGE 67.
- ② STRUT, 4" X 4" BY CUT TO FIT ( REF: 54" ) ( 24 REQD ). TOENAIL TO PIECES MARKED ① W/2-16d NAILS AT EACH END. SEE GENERAL NOTES "L" AND "T" ON PAGE 2.
- ③ VERTICAL STRUT BRACING, 2" X 4" X 7'-8" ( 4 REQD ). NAIL TO THE STRUTS W/3-10d NAILS AT EACH JOINT.
- ④ HORIZONTAL STRUT BRACING, 2" X 4" BY CAR WIDTH MINUS 5" ( 6 REQD ). NAIL TO THE STRUTS W/3-10d NAILS AT EACH JOINT.
- ⑤ GATE HOLD DOWN 2" X 4" BY LENGTH OF CENTER VOID PLUS 24" ( REF: 7'-0" ) ( 2 REQD ). POSITION UNDER THE ENDS OF THE CONTAINERS AND NAIL TO THE VERTICAL PIECES OF THE CENTER GATES W/2-10d NAILS AT EACH JOINT. SEE SPECIAL NOTE 6 ON PAGE 67.
- ⑥ GATE HOLD DOWN SUPPORT PIECE, 2" X 2" X 15" ( 4 REQD ). POSITION UNDER PIECE MARKED ⑤ AND NAIL TO A VERTICAL PIECE OF PIECE MARKED ① W/4-10d NAILS.
- ⑦ DOORWAY PROTECTION ( 2 REQD ). SEE THE "DOORWAY PROTECTION J" DETAIL ON PAGE 75. NAIL TO DOOR POSTS W/12d NAILS. SEE SPECIAL NOTE 7 ON PAGE 67.

SEE GENERAL NOTE "G" ON PAGE 2.

**SPECIAL NOTES:**

1. A 50'-6" LONG BY 9'-4" WIDE WOOD-LINED CONVENTIONAL TYPE BOXCAR EQUIPPED WITH 8'-0" WIDE DOOR OPENINGS IS SHOWN. WIDER CARS OF OTHER LENGTHS AND CARS HAVING WIDER OR NARROWER DOOR OPENINGS CAN BE USED. SEE GENERAL NOTE "D" ON PAGE 2 AND SPECIAL NOTE 9 BELOW.
2. THE PALLETIZED UNIT SHOWN IN THE TYPICAL LOAD ON PAGE 66 IS THE ROUTED DUNNAGE METHOD UNIT (BASIC HEIGHT). A MAXIMUM OF FORTY (40) OF THESE UNITS, FOR AN APPROXIMATE LADING WEIGHT OF 84,880 POUNDS CAN BE PLACED IN A 48'-6" LONG CAR WHEN USING THE DEPICTED PROCEDURES. IF A 60'-8" LONG BY 9'-4" OR WIDER CAR IS AVAILABLE, SIXTY-FOUR (64) PALLET UNITS FOR AN APPROXIMATE LADING WEIGHT OF 135,808 POUNDS CAN BE LOADED. SEE SPECIAL NOTE 9 FOR CENTER GATE MODIFICATIONS WHICH MAY BE REQUIRED IF 60' LONG CARS ARE TO BE USED.
3. ANTI-SWAY BRACING BETWEEN LATERALLY ADJACENT ROWS OF PALLET UNITS IS REQUIRED IF A CAR WHICH IS WIDER THAN 9'-4" IS FURNISHED FOR LOADING. SEE THE "ANTI-SWAY BRACE B" DETAIL ON PAGE 74 FOR CONSTRUCTION GUIDANCE. TO PREVENT LONGITUDINAL DISPLACEMENT OF THE ANTI-SWAY BRACE BETWEEN THE UPPER UNITS, A STOP PIECE MUST BE NAILED TO EACH CENTER GATE "U" AS SHOWN ON THE DETAIL ON PAGE 75. TO PREVENT DISPLACEMENT OF THE FLOORLINE ANTI-SWAY BRACE (IF USED), POSITION A DOUBLED 2" X 4" X 12" PIECE LONGITUDINALLY BETWEEN THE FILL PIECES ON THE GATE SO AS TO BE IN CONTACT WITH THE ANTI-SWAY BRACE AND NAIL TO THE CAR FLOOR W/3-12d NAILS EACH LAYER. IF DESIRED IN CARS HAVING AVAILABLE SIDEWALLS, 1" X 6" OR 2" X 6" FILL MATERIAL MAY BE NAILED TO ONE OR BOTH SIDEWALLS AT HEIGHTS SPECIFIED FOR THE DOORWAY PROTECTION HORIZONTAL PIECES, IN LIEU OF USING THE ANTI-SWAY BRACES. NOTE THAT THE TOTAL ACCUMULATED SPACE ACROSS A CAR SHOULD NOT EXCEED TWO INCHES (2").
4. CENTER GATE "U" MAY BE PARTIALLY FORMED FROM 1/2" OR THICKER PLYWOOD IF DESIRED. PLYWOOD MAY BE USED IN LIEU OF THE 2" X 6" HORIZONTAL PIECES. SEE THE "PLYWOOD CENTER GATE ALTERNATIVE" DETAIL ON PAGE 123 FOR GUIDANCE.
5. FOR EASE OF HANDLING, SPLIT CENTER GATES, WHICH ARE NOT DEPENDENT UPON THE WIDTH OF THE CAR, MAY BE USED AS AN ALTERNATIVE TO THE CAR-WIDTH GATES. IN LIEU OF EACH "CENTER GATE U", SHOWN AS PIECE MARKED ① IN THE LOAD ON PAGE 66, INSTALL TWO (2) "CENTER GATES S" AS SHOWN ON PAGE 73. AFTER THE SPLIT GATES AND STRUTS HAVE BEEN INSTALLED, THE SPLIT GATES MUST BE TIED TOGETHER AS DEPICTED BY THE "TIE PIECE APPLICATION" DETAIL ON PAGE 123.
6. AN ALTERNATIVE TO THE GATE HOLD DOWN SHOWN AS PIECE MARKED ⑤ IN THE LOAD ON PAGE 66 MAY BE USED, IF DESIRED, WHEN THE CAR FURNISHED FOR LOADING IS EQUIPPED WITH 8'-0" OR WIDER DOORS. NOTE THAT IN A CAR HAVING DOOR OPENINGS JUST 8'-0" WIDE IT MAY BE NECESSARY TO LAMINATE ONE OR TWO THICKNESS OF 2-INCH MATERIAL TO THE ADJACENT CENTER GATE VERTICAL PIECES TO PROVIDE AN AREA FOR NAILING OF PIECES MARKED ⑤ AND ⑥. AN ALTERNATIVE HOLD DOWN MUST BE USED WHEN THE CAR FURNISHED HAS DOOR OPENINGS LESS THAN 8'-0" WIDE. DOOR SPANNER TYPE HOLD DOWN AS SHOWN ON PAGE 125 MAY BE USED IF THE CAR HAS AVAILABLE SIDEWALLS, OR DOUBLED 2" X 3" HOLD DOWN PIECES MAY BE APPLIED TO THE CENTER GATES AS SHOWN BY THE CENTER GATE "U" DETAIL ON PAGE 75.
7. DOORWAY PROTECTION IS REQUIRED FOR ALL PALLET UNIT STACKS WHICH ARE COMPLETELY WITHIN THE DOORWAY AREA OR WHICH EXTEND INTO THE DOORWAY AREA BY ONE-HALF OR MORE OF THE STACK LENGTH. THE WOODEN GATE TYPE OF DOORWAY PROTECTION, SHOWN AS PIECES MARKED ⑦ IN THE LOAD ON PAGE 66, IS APPLICABLE FOR BOXCARS EQUIPPED WITH CONVENTIONAL SLIDING DOORS AND NAILABLE DOOR POSTS. REFER TO PAGES 126 THRU 128 FOR ALTERNATIVE DOORWAY PROTECTION FOR CARS EQUIPPED WITH CONVENTIONAL SLIDING DOORS. IF THE CAR BEING LOADED IS EQUIPPED WITH PLUG TYPE DOORS, NAILED FLOORLINE BLOCKING AND LOAD BUNDLING STRAPS MUST BE USED. SEE THE "ALTERNATIVE DOORWAY PROTECTION E" DETAIL ON PAGE 128 FOR GUIDANCE.
8. THE DEPICTED LOAD CAN BE REDUCED TO SUIT THE QUANTITY TO BE SHIPPED. A 2-TIER LOAD CAN BE REDUCED BY A MULTIPLE OF FOUR (4) PALLET UNITS OR A 1-TIER LOAD CAN BE REDUCED BY A MULTIPLE OF TWO (2) UNITS BY OMITTING ONE OR MORE LOAD UNITS FROM THE CENTER PORTION OF THE LOAD. OR, THE ENTIRE TOP TIER CAN BE OMITTED. FOR OTHER METHODS OF REDUCING A LOAD, AND FOR TYPICAL LCL PROCEDURES, REFER TO PAGES 92 THRU 120 FOR GUIDANCE.
9. IF A FULL LOAD IS TO BE SHIPPED IN A 60' LONG CAR IN AN OFFSET LOADING PATTERN, NINE (9) STRUTS WILL BE REQUIRED PER ROW/TIER. TO ACCOMMODATE THESE ADDITIONAL STRUTS, A VERTICAL PIECE MUST BE ADDED TO CENTER GATE "U" FOR EACH ROW AS SHOWN BY THE PHANTOMED LINES ON THE DETAIL ON PAGE 75.
10. IF PALLETIZED UNITS WHICH DO NOT CONTAIN A FULL QUANTITY OF CONTAINERS ARE TO BE TRANSPORTED, REFER TO PAGES 118 AND 120 FOR SHIPPING GUIDANCE.
11. FOR SHIPMENT OF ONE OR MORE LEFTOVER CONTAINERS, SEE THE "PROCEDURES FOR SHIPMENT OF LEFTOVER CONTAINERS" ON PAGE 119 FOR GUIDANCE.

BILL OF MATERIAL		
LUMBER	LINEAR FEET	BOARD FEET
1" X 6"	64	32
2" X 2"	108	36
2" X 3"	30	15
2" X 4"	99	66
2" X 6"	193	193
4" X 4"	108	144
NAILS	NO. REQD	POUNDS
6d (2")	48	1/2
10d (3")	456	7-1/4
12d (3-1/4")	28	1/2
16d (3-1/2")	96	2-1/4

**LOAD AS SHOWN**

ITEM	QUANTITY	WEIGHT (APPROX)
PALLET UNIT	52	110,344 LBS
DUNNAGE		983 LBS
TOTAL WEIGHT		111,327 LBS

ROUTED DUNNAGE METHOD UNIT (BASIC HEIGHT)  
52-UNIT LOAD IN 50'-6" LONG BY 9'-4" WIDE CONVENTIONAL BOX CAR

**CAR EQUIPMENT REQUIRED**

ADJUSTABLE WALL MEMBER (SEE "NOTE 1" BELOW)	40
CROSS MEMBER	27
DOORWAY MEMBER	8

NOTE 1: FOR CARS EQUIPPED WITH FIXED WALL MEMBERS LOCATED AT THE HEIGHTS SPECIFIED IN "SECTION T-T", OMIT ALL REFERENCE TO "ADJUSTABLE WALL MEMBERS".

DIRECTION OF ARROW INDICATES BASE END OF CONTAINERS. SEE GENERAL NOTE "E" ON PAGE 2.

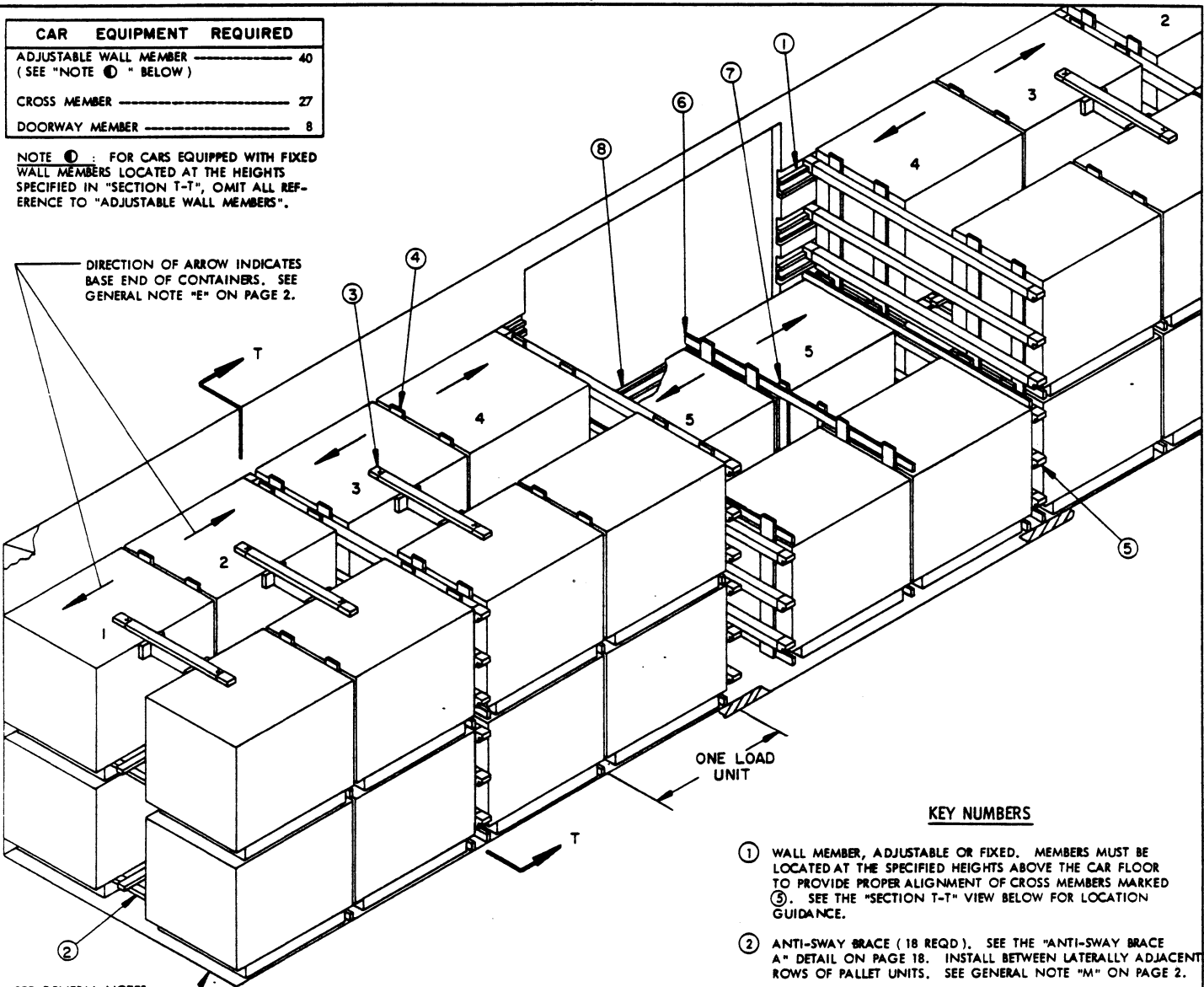

**ISOMETRIC VIEW**

EACH DIMENSIONED HEIGHT ABOVE THE CAR FLOOR TO AN ADJUSTABLE OR FIXED WALL MEMBER MARKED 1 AND/OR A DOORWAY MEMBER MARKED 8 IS SPECIFIED TO LOCATE THE CENTER LINE OF A CROSS MEMBER.

SEE GENERAL NOTES "D" AND "G" ON PAGE 2 AND SPECIAL NOTE 3 ON PAGE 69.

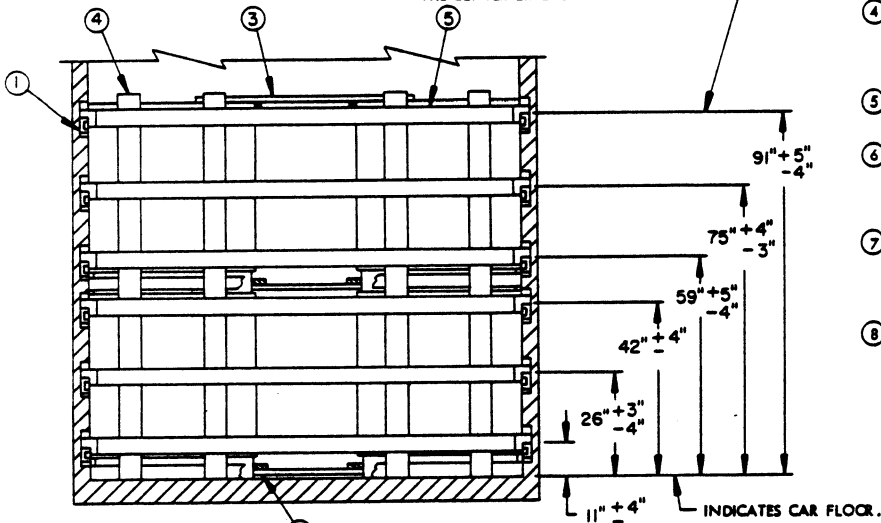

**SECTION T-T**

ROUTED DUNNAGE METHOD UNIT (BASIC HEIGHT)  
36-UNIT LOAD IN A 50'-6" LONG BY 9'-0" WIDE BOX CAR EQUIPPED WITH MECHANICAL BRACING DEVICES

**KEY NUMBERS**

- 1 WALL MEMBER, ADJUSTABLE OR FIXED. MEMBERS MUST BE LOCATED AT THE SPECIFIED HEIGHTS ABOVE THE CAR FLOOR TO PROVIDE PROPER ALIGNMENT OF CROSS MEMBERS MARKED 3. SEE THE "SECTION T-T" VIEW BELOW FOR LOCATION GUIDANCE.
- 2 ANTI-SWAY BRACE (18 REQD). SEE THE "ANTI-SWAY BRACE A" DETAIL ON PAGE 18. INSTALL BETWEEN LATERALLY ADJACENT ROWS OF PALLET UNITS. SEE GENERAL NOTE "M" ON PAGE 2.
- 3 TOP-OF-LOAD ANTI-SWAY BRACE (6 REQD). SEE THE "TOP-OF-LOAD ANTI-SWAY BRACE B" DETAIL ON PAGE 46. WIRE TIE TO STRAPPING BOARDS OF UNIT WITH NO. 14 GAGE WIRE AS TYPICALLY SHOWN BY THE "TIE WIRE APPLICATION B" DETAIL ON PAGE 122. SEE SPECIAL NOTE 4 ON PAGE 69.
- 4 SEPARATOR GATE FOR 2-HIGH (10 REQD). SEE THE "SEPARATOR GATE K" DETAIL ON PAGE 73. AS APPLICABLE, POSITION WITH THE HORIZONTAL PIECES AGAINST THE ALREADY-LOADED UNITS. SEE SPECIAL NOTES 5 AND 7 ON PAGE 69.
- 5 CROSS MEMBER (27 REQD). SEE GENERAL NOTE "W" ON PAGE 2.
- 6 SEPARATOR GATE FOR 1-HIGH (3 REQD). SEE THE "SEPARATOR GATE K" DETAIL ON PAGE 73. AS APPLICABLE, POSITION WITH THE HORIZONTAL PIECES AGAINST THE ALREADY-LOADED UNITS. SEE SPECIAL NOTES 5 THRU 7 ON PAGE 69.
- 7 STOP PIECE, 1" X 4" X 55" (4 REQD). POSITION AGAINST PALLET UNITS IN THE DOORWAY AND NAIL TO THE HORIZONTAL PIECES ON PIECE MARKED 6 W/3-6d NAILS AT EACH JOINT AND CLINCH. SEE SPECIAL NOTE 6 ON PAGE 69.
- 8 DOORWAY MEMBER (6 REQD). SEE THE "SECTION T-T" VIEW AT LEFT FOR LOCATION GUIDANCE. SEE SPECIAL NOTE 8 ON PAGE 69.

**SPECIAL NOTES:**

1. A 50'-6" LONG BY 9'-0" WIDE ( INSIDE CLEARANCE ) WOOD-LINED BOX CAR EQUIPPED WITH ADJUSTABLE AND/OR FIXED WALL MEMBERS, AND WITH 10'-0" WIDE DOOR OPENINGS IS SHOWN. CARS OF OTHER DIMENSIONS AND CARS HAVING WIDER OR NARROWER DOOR OPENINGS CAN BE USED. SEE GENERAL NOTE "D" ON PAGE 2.
2. THE PALLETIZED UNIT SHOWN IN THE TYPICAL LOAD ON PAGE 68 IS THE ROUTED DUNNAGE METHOD UNIT ( BASIC HEIGHT ). A MAXIMUM OF TWENTY-EIGHT ( 28 ) OF THESE UNITS, FOR AN APPROXIMATE LADING WEIGHT OF 59,416 POUNDS, CAN BE PLACED IN A 40'-6" LONG CAR.
3. IF A CAR HAS BOWED END WALLS WHICH ARE BOWED OUTWARD TWO INCHES ( 2" ) OR MORE EITHER FROM SIDE-TO-SIDE OR FROM FLOOR-TO-ROOF, CROSS MEMBERS CAN BE INSTALLED NEAR THE END WALL OF THE CAR TO PROVIDE A "SQUARED END" RATHER THAN INSTALLING DUNNAGE AS SPECIFIED IN GENERAL NOTE "G" ON PAGE 2. THESE CROSS MEMBERS SHOULD BE INSTALLED AT THE SAME HEIGHTS AS THE CROSS MEMBERS USED THROUGHOUT THE LOAD AS BLOCKING MEMBERS. A SEPARATOR GATE, SHOWN AS PIECE MARKED ④, MUST BE POSITIONED AGAINST THESE CROSS MEMBERS PRIOR TO LOADING.
4. TOP-OF-LOAD ANTI-SWAY BRACES, SHOWN AS PIECES MARKED ③ IN THE LOAD ON PAGE 68, MUST BE INSTALLED IN EACH END OF THE CAR AND WIRE TIED TO THE STRAPPING BOARDS WITH NO. 14 GAGE WIRE AS TYPICALLY SHOWN BY THE "TIE WIRE APPLICATION B" DETAIL ON PAGE 122. THREE ( 3 ) BRACES ARE REQUIRED IN EACH END OF A LOAD REGARDLESS OF THE CAR LENGTH.
5. TO FACILITATE POSITIONING OF THE PALLET UNITS AS LOADING PROGRESSES, POSITION PALLET UNIT STACKS AGAINST THE END WALL, THEN POSITION A SEPARATOR GATE, SHOWN AS PIECE MARKED ④, SO THE 1" X 4" TIE PIECES ARE LOCATED UNDER THE "OVERHANG" OF THE PALLET UNITS. REPEAT THIS PROCEDURE FOR THE REMAINING STACKS.
6. SEPARATOR GATES IN THE DOORWAY MUST BE PREVENTED FROM SHIFTING INTO A DOOR OPENING BY THE APPLICATION OF THE STOP PIECES, PIECES MARKED ⑦. IN CARS EQUIPPED WITH STAGGERED DOORS, STOP PIECES MAY BE REQUIRED ON UP TO FOUR SEPARATOR GATES.
7. SEPARATOR GATES MAY BE FORMED FROM 3/8" OR THICKER PLYWOOD IN LIEU OF DIMENSIONAL LUMBER, IF DESIRED. SEE THE "ALTERNATIVE SEPARATOR GATE" DETAIL ON PAGE 122 FOR CONSTRUCTION GUIDANCE.
8. IF THE CAR BEING LOADED IS EQUIPPED WITH AT LEAST TWELVE ( 12 ) DOORWAY MEMBERS, AN ADDITIONAL FOUR PALLET UNITS CAN BE LOADED IN THE DOORWAY AREA.
9. THE DEPICTED LOAD CAN BE REDUCED TO SUIT THE QUANTITY TO BE SHIPPED. A LOAD MAY BE REDUCED BY MULTIPLES OF TWO ( 2 ) PALLET UNITS BY OMITTING LATERALLY ADJACENT UNITS FROM THE TOP LAYER OF ONE OR MORE LOAD UNITS, OR BY MULTIPLES OF FOUR ( 4 ) PALLET UNITS BY OMITTING ONE OR MORE ENTIRE LOAD UNITS FROM THE CENTER PORTION OF THE LOAD. TO REDUCE A LOAD BY ONE ( 1 ) PALLET UNIT, REFER TO THE LCL PROCEDURES ON PAGES 90 AND 91 FOR GUIDANCE.
10. FOR SHIPMENT OF ONE OR MORE LEFTOVER CONTAINERS, SEE THE "PROCEDURES FOR SHIPMENT OF LEFTOVER CONTAINERS" ON PAGE 119 FOR GUIDANCE.

**BILL OF MATERIAL**

LUMBER	LINEAR FEET	BOARD FEET
1" X 4"	431	144
1" X 6"	385	193
2" X 4"	258	172
2" X 6"	19	19
NAILS	NO. REQD	POUNDS
6d ( 2" )	424	2-1/2
10d ( 3" )	300	4-3/4
WIRE, NO. 14 GAGE	60' REQD	1 LB

**LOAD AS SHOWN**

ITEM	QUANTITY	WEIGHT ( APPROX )
PALLET UNIT	36	76,392 LBS
DUNNAGE		1,065 LBS
<b>TOTAL WEIGHT</b>		<b>77,457 LBS</b>

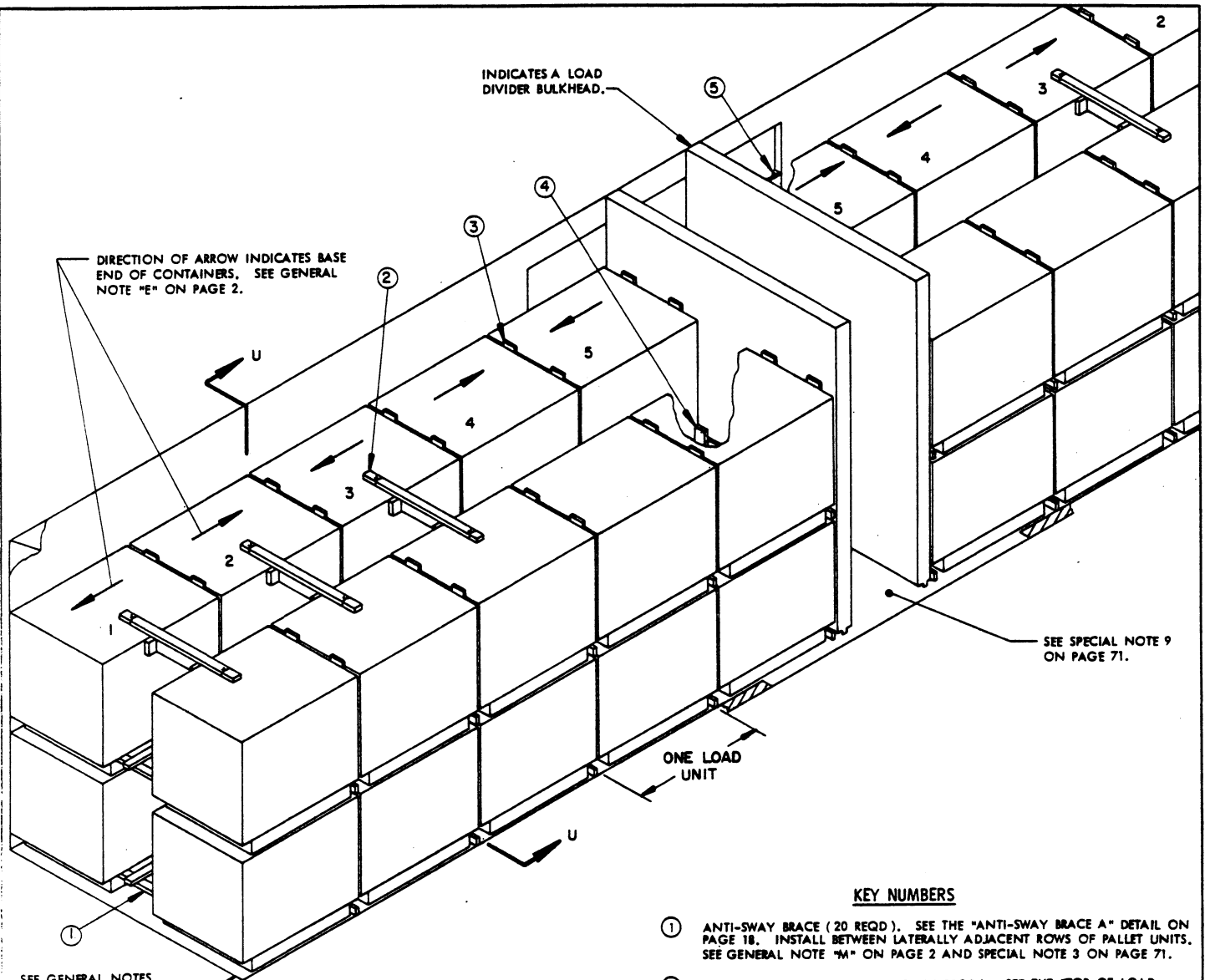

DIRECTION OF ARROW INDICATES BASE END OF CONTAINERS. SEE GENERAL NOTE "E" ON PAGE 2.

INDICATES A LOAD DIVIDER BULKHEAD.

SEE SPECIAL NOTE 9 ON PAGE 71.

SEE GENERAL NOTES "D" AND "G" ON PAGE 2.

ISOMETRIC VIEW

**KEY NUMBERS**

- ① ANTI-SWAY BRACE (20 REQD). SEE THE "ANTI-SWAY BRACE A" DETAIL ON PAGE 18. INSTALL BETWEEN LATERALLY ADJACENT ROWS OF PALLET UNITS. SEE GENERAL NOTE "M" ON PAGE 2 AND SPECIAL NOTE 3 ON PAGE 71.
- ② TOP-OF-LOAD ANTI-SWAY BRACE (6 REQD). SEE THE "TOP-OF-LOAD ANTI-SWAY BRACE B" DETAIL ON PAGE 46. WIRE TIE TO STRAPPING BOARDS WITH NO. 14 GAGE WIRE AS TYPICALLY SHOWN BY THE "TIE WIRE APPLICATION B" DETAIL ON PAGE 122. SEE SPECIAL NOTE 4 ON PAGE 71.
- ③ SEPARATOR GATE (10 REQD). SEE THE "SEPARATOR GATE K" DETAIL ON PAGE 73. POSITION WITH THE HORIZONTAL PIECES AGAINST THE ALREADY-LOADED UNITS. SEE SPECIAL NOTES 5 AND 7 ON PAGE 71.
- ④ STOP PIECE, 1" X 4" X 55" (4 REQD). POSITION AGAINST PALLET UNITS IN THE DOORWAY AND NAIL TO THE HORIZONTAL PIECES ON PIECE MARKED ③ W/3-6d NAILS AT EACH JOINT AND CLINCH. SEE SPECIAL NOTE 6 ON PAGE 71.
- ⑤ DOORWAY PROTECTION (2 REQD). SEE THE "DOORWAY PROTECTION H" DETAIL ON PAGE 74. NAIL TO THE DOOR POSTS W/12d NAILS. SEE SPECIAL NOTE 8 ON PAGE 71.

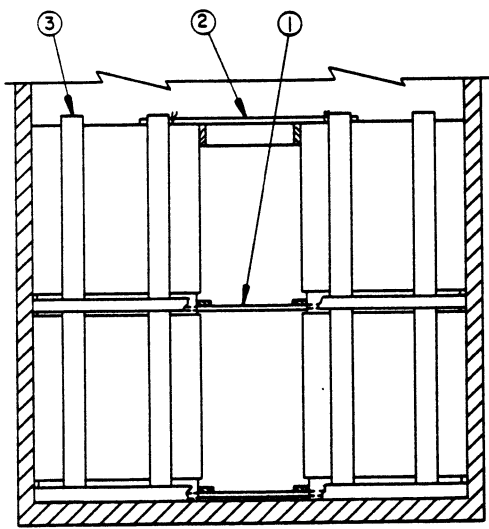

SECTION U-U

ROUTED DUNNAGE METHOD UNIT ( BASIC HEIGHT )  
 40-UNIT LOAD IN A 50'-6" LONG BY 9'-2" WIDE BOX CAR EQUIPPED WITH LOAD DIVIDERS

(SPECIAL NOTES CONTINUED)

- 10. THE DEPICTED LOAD CAN BE REDUCED TO SUIT THE QUANTITY TO BE SHIPPED. A 2-TIER LOAD CAN BE REDUCED BY A MULTIPLE OF FOUR (4) PALLET UNITS OR A 1-TIER LOAD CAN BE REDUCED BY A MULTIPLE OF TWO (2) UNITS BY OMITTING ONE OR MORE LOAD UNITS FROM THE CENTER PORTION OF THE LOAD. OR, THE ENTIRE TOP TIER CAN BE OMITTED. FOR OTHER METHODS OF REDUCING A LOAD, AND FOR TYPICAL LCL PROCEDURES, REFER TO PAGES 94 THRU 105 AND GENERAL NOTE "FF" ON PAGE 3 FOR GUIDANCE.
- 11. IF PALLET UNITS WHICH DO NOT CONTAIN A FULL QUANTITY OF CONTAINERS ARE TO BE TRANSPORTED, REFER TO PAGE 117 AND/OR PAGES 118 AND 120 FOR SHIPPING GUIDANCE.
- 12. FOR SHIPMENT OF ONE OR MORE LEFTOVER CONTAINERS, SEE THE "PROCEDURES FOR SHIPMENT OF LEFTOVER CONTAINERS" ON PAGE 119 FOR GUIDANCE.

SPECIAL NOTES:

- 1. A 50'-6" LONG BY 9'-2" WIDE WOOD-LINED CUSHIONED BOX CAR EQUIPPED WITH LOAD DIVIDER BULKHEADS AND WITH 10'-0" WIDE DOOR OPENINGS IS SHOWN. CARS OF OTHER DIMENSIONS AND CARS HAVING NARROWER OR WIDER DOOR OPENINGS CAN BE USED. SEE GENERAL NOTES "AA" THRU "EE" ON PAGE 3.
- 2. THE PALLET UNIT SHOWN IN THE TYPICAL LOAD ON PAGE 70 IS THE ROUTED DUNNAGE METHOD UNIT (BASIC HEIGHT). A MAXIMUM OF FORTY-EIGHT (48) OF THESE UNITS, FOR AN APPROXIMATE LADING WEIGHT OF 101,856 POUNDS, CAN BE PLACED IN A 60'-8" LONG CAR, OR A MAXIMUM OF THIRTY-TWO (32) UNITS CAN BE LOADED IN A 40'-6" CAR FOR AN APPROXIMATE LADING WEIGHT OF 67,904 POUNDS, WHEN USING THE DEPICTED PROCEDURES. IF CARS 9'-4" OR WIDER ARE AVAILABLE, THE CROSSWISE LOADING PATTERN SHOWN ON PAGE 66 MAY BE EMPLOYED. SIXTY-FOUR (64) PALLET UNITS FOR AN APPROXIMATE LADING WEIGHT OF 135,808 POUNDS CAN BE PLACED IN A 60'-8" LONG CAR, FIFTY-TWO (52) UNITS CAN BE LOADED IN A 50'-6" LONG CAR FOR AN APPROXIMATE LADING WEIGHT OF 110,344 POUNDS, AND FORTY (40) UNITS CAN BE LOADED IN A 40'-6" LONG CAR FOR AN APPROXIMATE LADING WEIGHT OF 84,880 POUNDS.
- 3. IF THE "ALTERNATIVE DOORWAY PROTECTION F" PROCEDURES AS SHOWN ON PAGE 128 ARE USED IN LIEU OF THE WOODEN DOOR GATE TYPE PROTECTION, PIECE MARKED ⑤, NAILED FLOORLINE BLOCKING MUST BE USED IN LIEU OF THE LOWER ANTI-SWAY BRACE IN THE DOORWAY AREA. NAILED BLOCKING IS REQUIRED FOR ALL PALLET STACKS WHICH ARE COMPLETELY WITHIN THE DOORWAY AREA OR WHICH EXTEND INTO THE DOORWAY AREA BY ONE-HALF OR MORE OF THE STACK WIDTH ON EITHER SIDE OF THE CAR.
- 4. TOP-OF-LOAD ANTI-SWAY BRACES, SHOWN AS PIECES MARKED ② IN THE LOAD ON PAGE 70, MUST BE INSTALLED IN EACH END OF THE CAR AND WIRE TIED TO STRAPPING BOARDS WITH NO. 14 GAGE WIRE AS TYPICALLY SHOWN BY THE "TIE WIRE APPLICATION B" DETAIL ON PAGE 122. THREE (3) BRACES ARE REQUIRED IN EACH END OF A LOAD REGARDLESS OF THE CAR LENGTH.
- 5. TO FACILITATE POSITIONING OF THE PALLET UNITS AS LOADING PROGRESSES, POSITION PALLET UNIT STACKS AGAINST THE END WALL, THEN POSITION A SEPARATOR GATE, SHOWN AS PIECE MARKED ③, SO THE 1" X 4" TIE PIECES ARE LOCATED UNDER THE "OVERHANG" OF THE PALLET UNITS. REPEAT THIS PROCEDURE FOR THE REMAINING STACKS.
- 6. SEPARATOR GATES IN THE DOORWAY MUST BE PREVENTED FROM SHIFTING INTO A DOOR OPENING BY THE APPLICATION OF THE STOP PIECES, PIECES MARKED ④. IN CARS EQUIPPED WITH STAGGERED DOORS, STOP PIECES MAY BE REQUIRED ON UP TO FOUR SEPARATOR GATES.
- 7. SEPARATOR GATES MAY BE FORMED FROM 3/8" OR THICKER PLYWOOD IN LIEU OF DIMENSIONAL LUMBER, IF DESIRED. SEE THE "ALTERNATIVE SEPARATOR GATE" DETAIL ON PAGE 122 FOR CONSTRUCTION GUIDANCE.
- 8. DOORWAY PROTECTION IS REQUIRED FOR ALL PALLET UNIT STACKS WHICH ARE COMPLETELY WITHIN THE DOORWAY AREA OR WHICH EXTEND INTO THE DOORWAY AREA BY ONE-HALF OR MORE OF THE STACK WIDTH. THE WOODEN GATE TYPE OF DOORWAY PROTECTION, SHOWN AS PIECES MARKED ⑤ IN THE LOAD ON PAGE 70 IS APPLICABLE FOR BOX CARS EQUIPPED WITH CONVENTIONAL SLIDING DOORS AND NAILABLE DOOR POSTS. REFER TO PAGES 126 THRU 128 FOR ALTERNATIVE DOORWAY PROTECTION FOR CARS EQUIPPED WITH CONVENTIONAL SLIDING DOORS. IF THE CAR BEING LOADED IS EQUIPPED WITH PLUG TYPE DOORS, NAILED FLOORLINE BLOCKING AND LOAD BUNDLING STRAPS MUST BE USED. SEE THE "ALTERNATIVE DOORWAY PROTECTION F" DETAIL ON PAGE 128 FOR GUIDANCE IF THE PALLET UNITS ARE POSITIONED AS SHOWN ON PAGE 70. SEE THE "ALTERNATIVE DOORWAY PROTECTION E" DETAIL ON THAT PAGE IF THE PALLET UNITS ARE POSITIONED CROSSWISE.
- 9. A STRUT ASSEMBLY, SHOWN AS PIECE MARKED ⑥ IN THE LOAD ON PAGE 42, IS REQUIRED BETWEEN THE LOAD DIVIDER BULKHEADS WHEN THE LOAD IN EITHER END OF THE CAR IS 50,000 POUNDS OR MORE. FOR THE DEPICTED PALLET UNIT, A STRUT ASSEMBLY WILL BE REQUIRED IF THE LOAD IN ONE END OF THE CAR CONSISTS OF MORE THAN FIVE (5) LOAD UNITS, WHICH WOULD BE THE CASE IF AN OFFSET LOADING PATTERN IS EMPLOYED. THE STRUT ASSEMBLY WILL ALWAYS BE REQUIRED FOR FULL LOADS IN 60' OR LONGER CARS.

(CONTINUED AT LEFT)

BILL OF MATERIAL		
LUMBER	LINEAR FEET	BOARD FEET
1" X 4"	201	67
1" X 6"	410	205
2" X 3"	32	16
2" X 4"	293	196
2" X 6"	21	21
NAILS	NO. REQD	POUNDS
6d (2")	312	2
10d (3")	324	5
12d (3-1/4")	32	3/4
WIRE, NO. 14 GAGE	60' REQD	1 LB

LOAD AS SHOWN

ITEM	QUANTITY	WEIGHT (APPROX)
PALLET UNIT	40	84,880 LBS
DUNNAGE		1,019 LBS
TOTAL WEIGHT		85,899 LBS

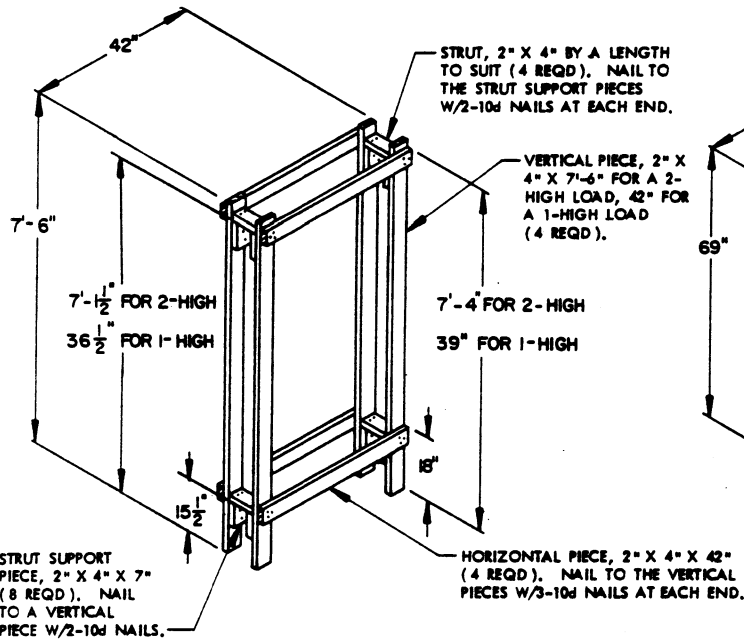

**CRIB FILL J**

CRIB FILL ASSEMBLIES "J" AND "K" SHOULD BE PRE-FABRICATED. CONSTRUCT TO BE 1/2" TO 3/4" LESS IN WIDTH THAN THE DISTANCE BETWEEN LATERALLY ADJACENT ROWS OF PALLET UNITS.

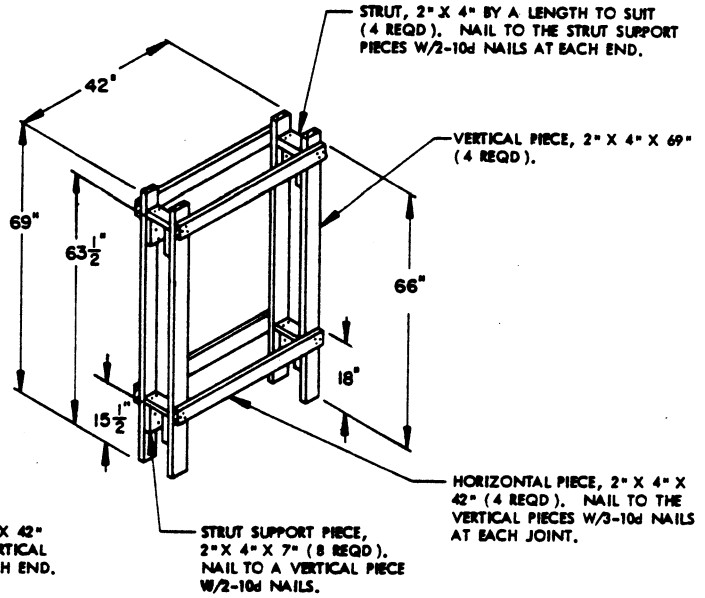

**CRIB FILL K**

CRIB FILL "K" IS NOT REQUIRED FOR A 1-HIGH LOAD; THE CRIB FILL "J" WILL BE USED THROUGHOUT THE LENGTH OF THE LOAD.

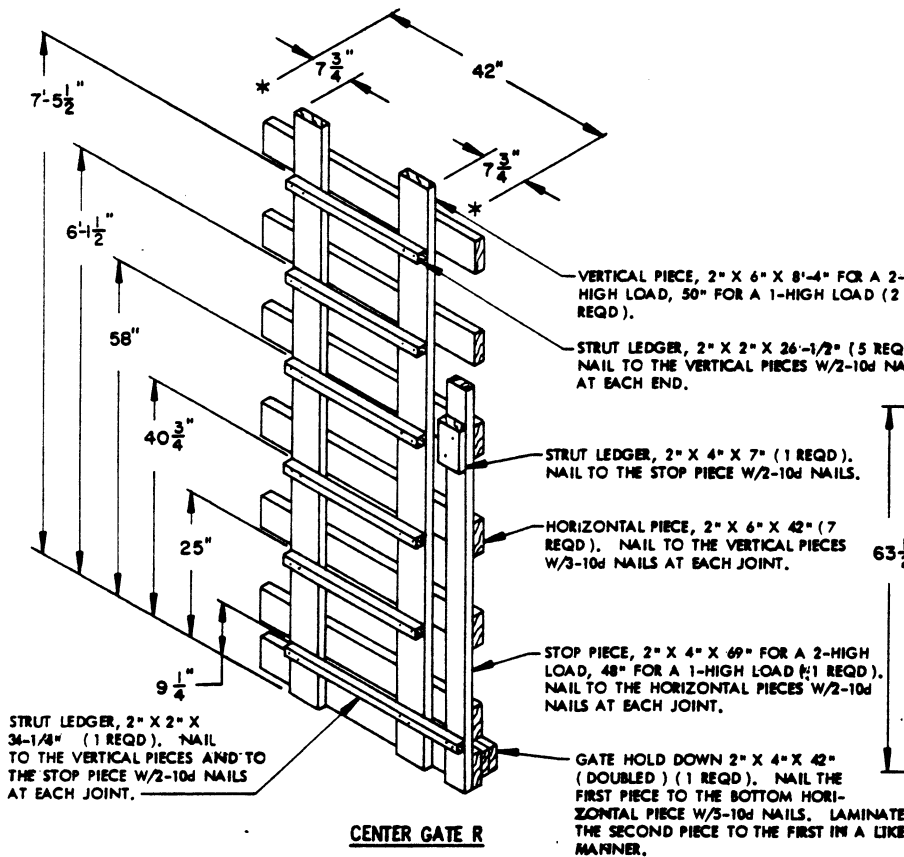

**CENTER GATE R**

1 RIGHT HAND AND 1 LEFT HAND GATE REQUIRED.

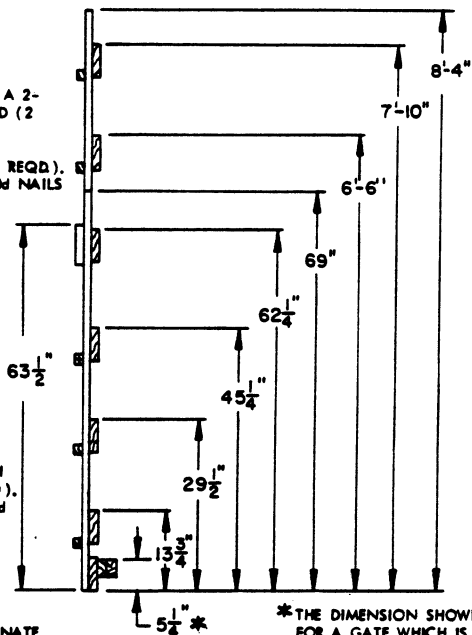

**END VIEW**

\*THE DIMENSION SHOWN IS FOR A GATE WHICH IS TO BE POSITIONED AGAINST THE BELL ENDS OF THE CONTAINERS. THIS DIMENSION WILL BE 5-3/4" FOR THE BASE END OF THE UNIT.



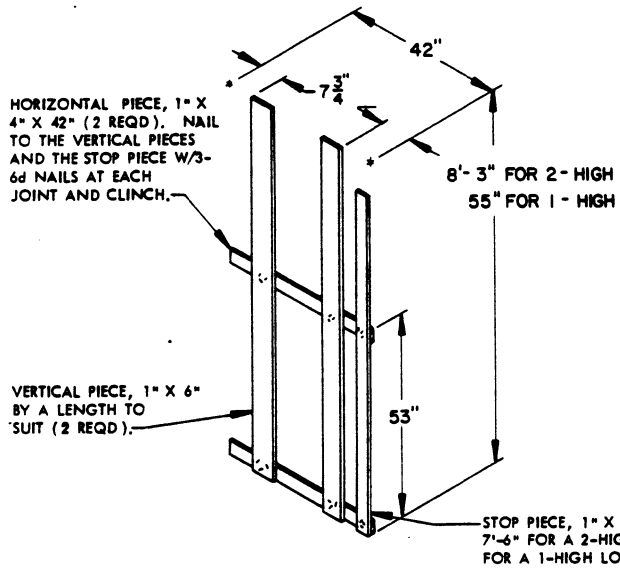

**SEPARATOR GATE J**  
RIGHT HAND AND LEFT HAND GATES ARE REQUIRED. A RIGHT HAND GATE IS SHOWN.

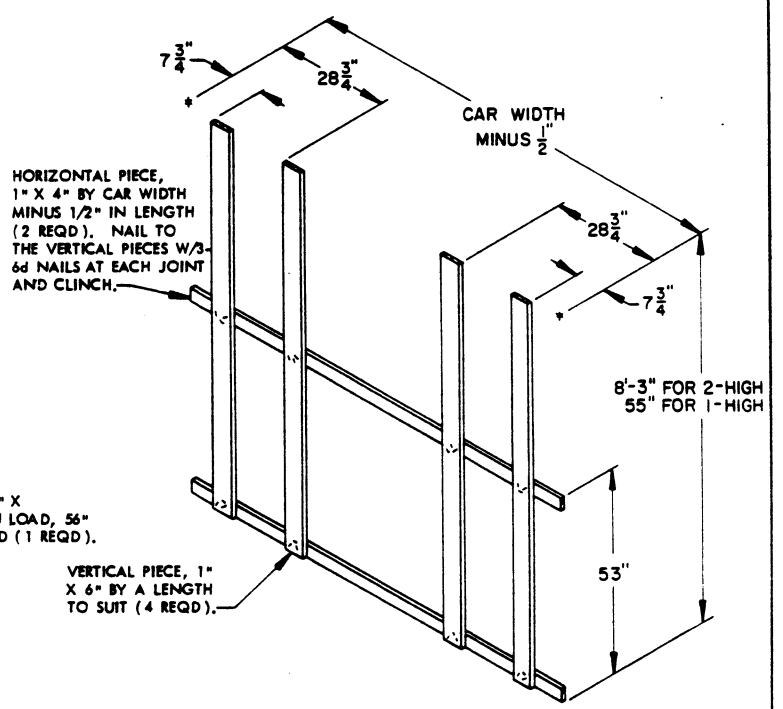

**SEPARATOR GATE K**

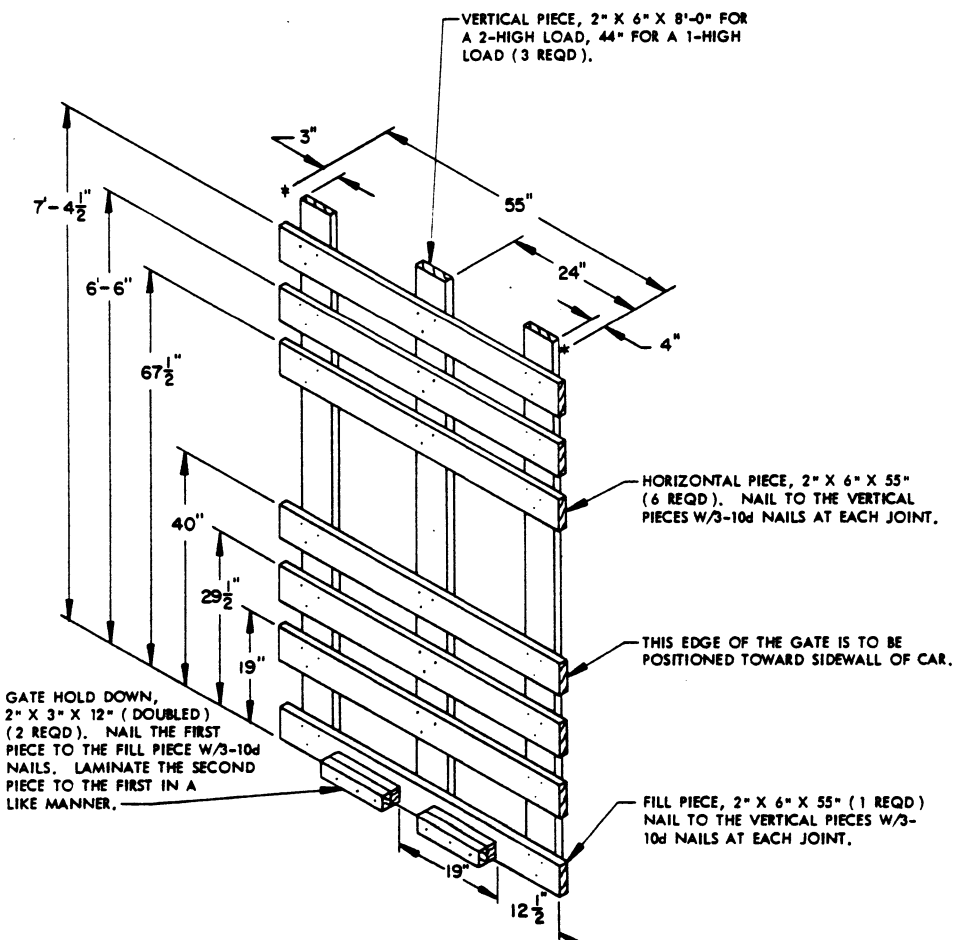

**CENTER GATE S**  
1 RIGHT HAND AND 1 LEFT HAND GATE REQUIRED.

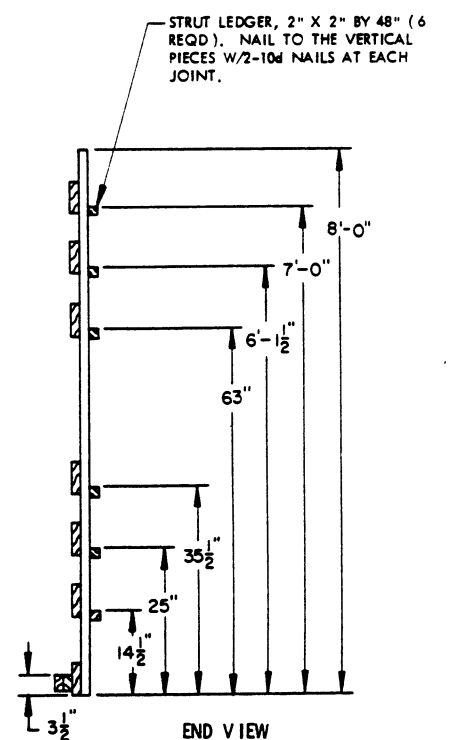

NOTE THAT THE TWO UPPER STRUT LEDGERS FOR EACH TIER MAY NEED TO BE APPLIED AFTER THE NEXT LOWER LEVEL STRUTS HAVE BEEN INSTALLED.

CROSS BRACE, 2" X 4" BY A LENGTH TO SUIT (2 REQD).

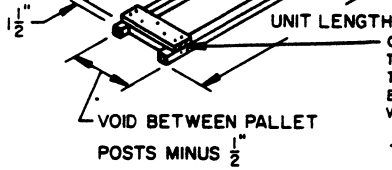

LONGITUDINAL PIECE, 2" X 2" BY UNIT LENGTH (2 REQD). NAIL TO THE CROSS BRACES W/2-10d NAILS AT EACH JOINT.

CLEAT, 1" X 4" BY A LENGTH TO SUIT. NAIL TO THE LONGITUDINAL PIECES W/2-6d NAILS AT EACH END AND TO A CROSS BRACE W/3-6d NAILS.

VERTICAL PIECE, 2" X 3" X 8'-0" (2 REQD). NAIL TO A DOOR POST W/12d NAILS.

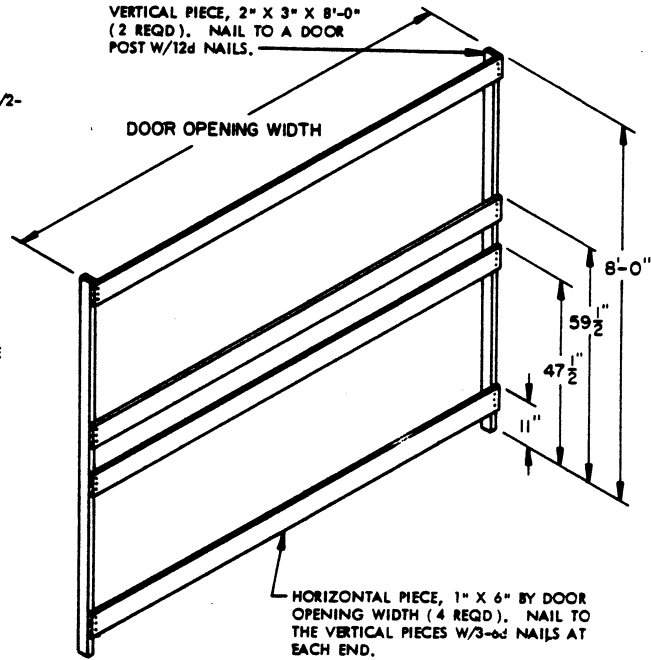

HORIZONTAL PIECE, 1" X 6" BY DOOR OPENING WIDTH (4 REQD). NAIL TO THE VERTICAL PIECES W/3-6d NAILS AT EACH END.

**ANTI-SWAY BRACE B**

SEE SPECIAL NOTE 3 ON PAGE 67 AND/OR PAGE 81.

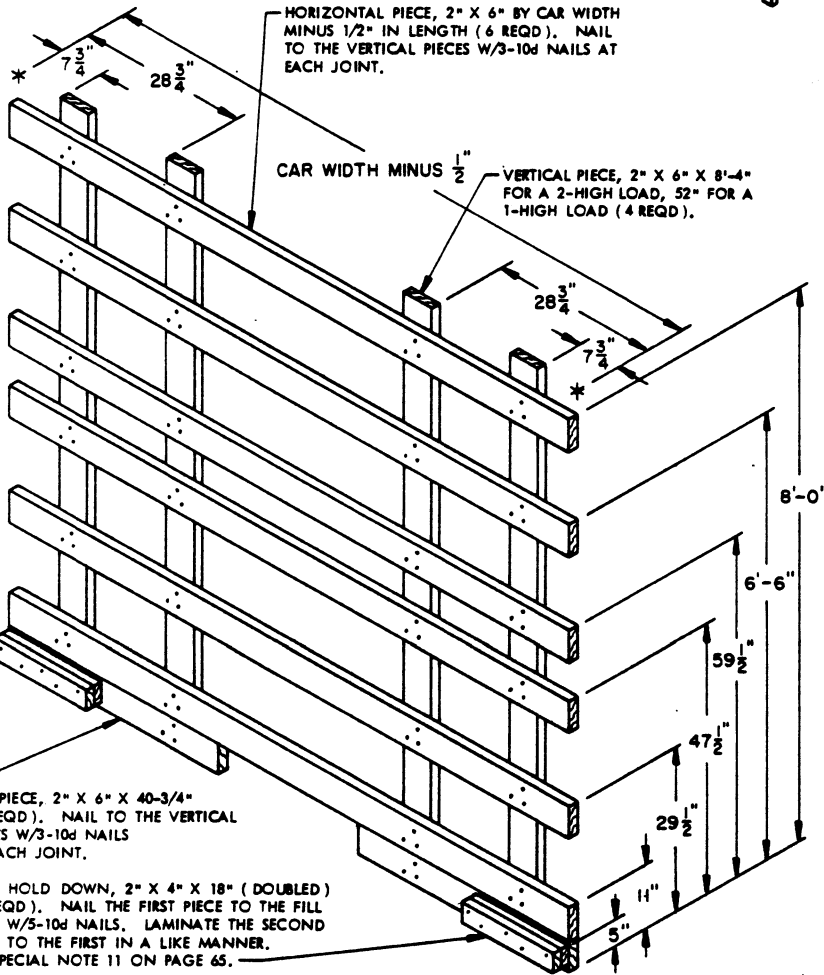

HORIZONTAL PIECE, 2" X 6" BY CAR WIDTH MINUS 1/2" IN LENGTH (6 REQD). NAIL TO THE VERTICAL PIECES W/3-10d NAILS AT EACH JOINT.

CAR WIDTH MINUS 1/2" VERTICAL PIECE, 2" X 6" X 8'-4" FOR A 2-HIGH LOAD, 52" FOR A 1-HIGH LOAD (4 REQD).

FILL PIECE, 2" X 6" X 40-3/4" (2 REQD). NAIL TO THE VERTICAL PIECES W/3-10d NAILS AT EACH JOINT.

GATE HOLD DOWN, 2" X 4" X 18" (DOUBLED) (2 REQD). NAIL THE FIRST PIECE TO THE FILL PIECE W/5-10d NAILS. LAMINATE THE SECOND PIECE TO THE FIRST IN A LIKE MANNER. SEE SPECIAL NOTE 11 ON PAGE 65.

**CENTER GATE T**

**DOORWAY PROTECTION H**

STRUT LEDGER, 2" X 2" BY CAR WIDTH MINUS 16" IN LENGTH (6 REQD). NAIL TO THE VERTICAL PIECES W/2-10d NAILS AT EACH JOINT.

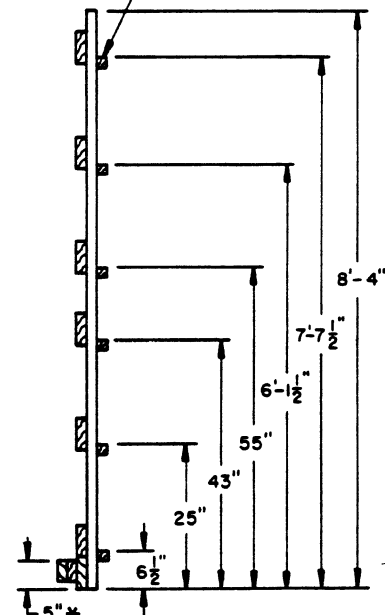

**END VIEW**

\* THE DIMENSION SHOWN IS FOR A GATE WHICH IS TO BE POSITIONED AGAINST THE BELL END OF THE CONTAINERS. THIS DIMENSION WILL BE 5-3/4" FOR THE BASE END OF THE UNIT.

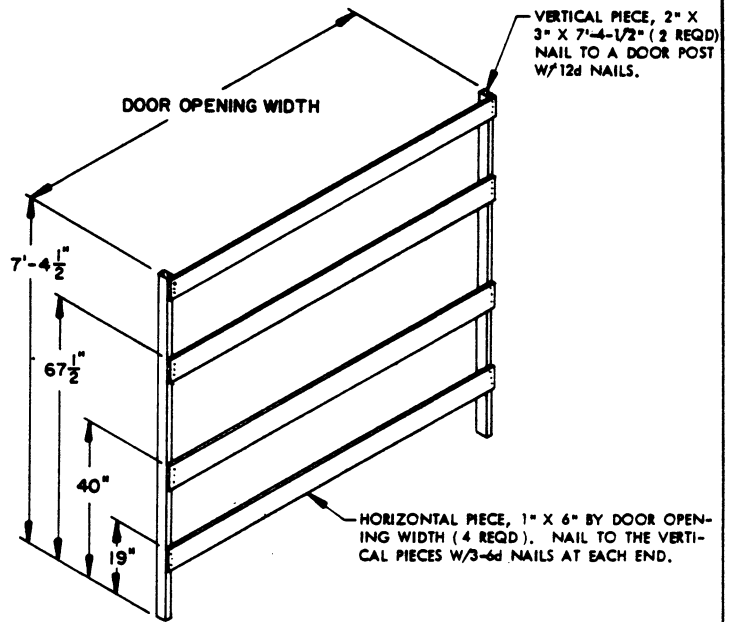

**DOORWAY PROTECTION J**

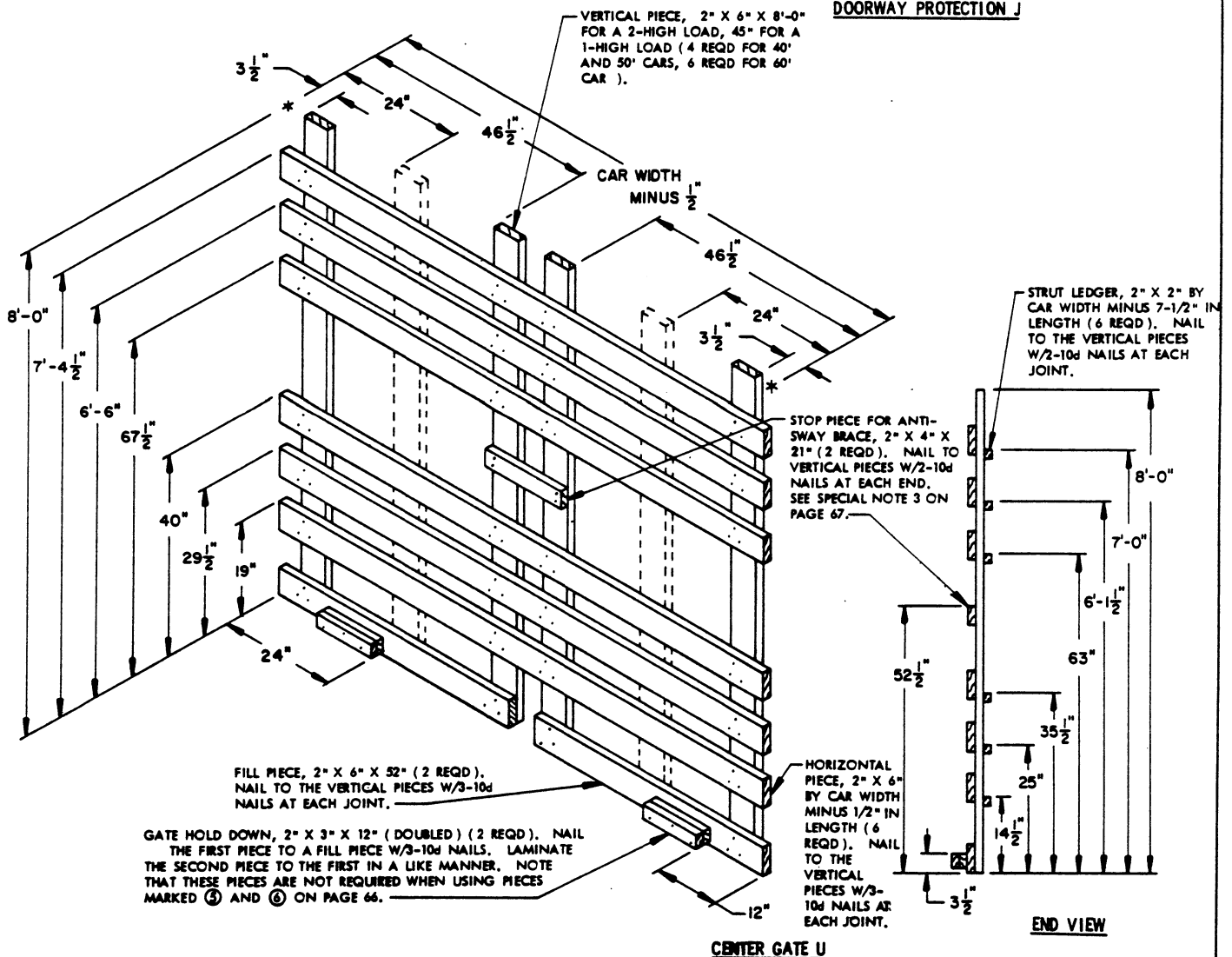

**DETAILS FOR ROUTED DUNNAGE METHOD UNIT ( BASIC HEIGHT )**

DIRECTION OF ARROW INDICATES  
BASE END OF CONTAINERS. SEE  
GENERAL NOTE "E" ON PAGE 2.

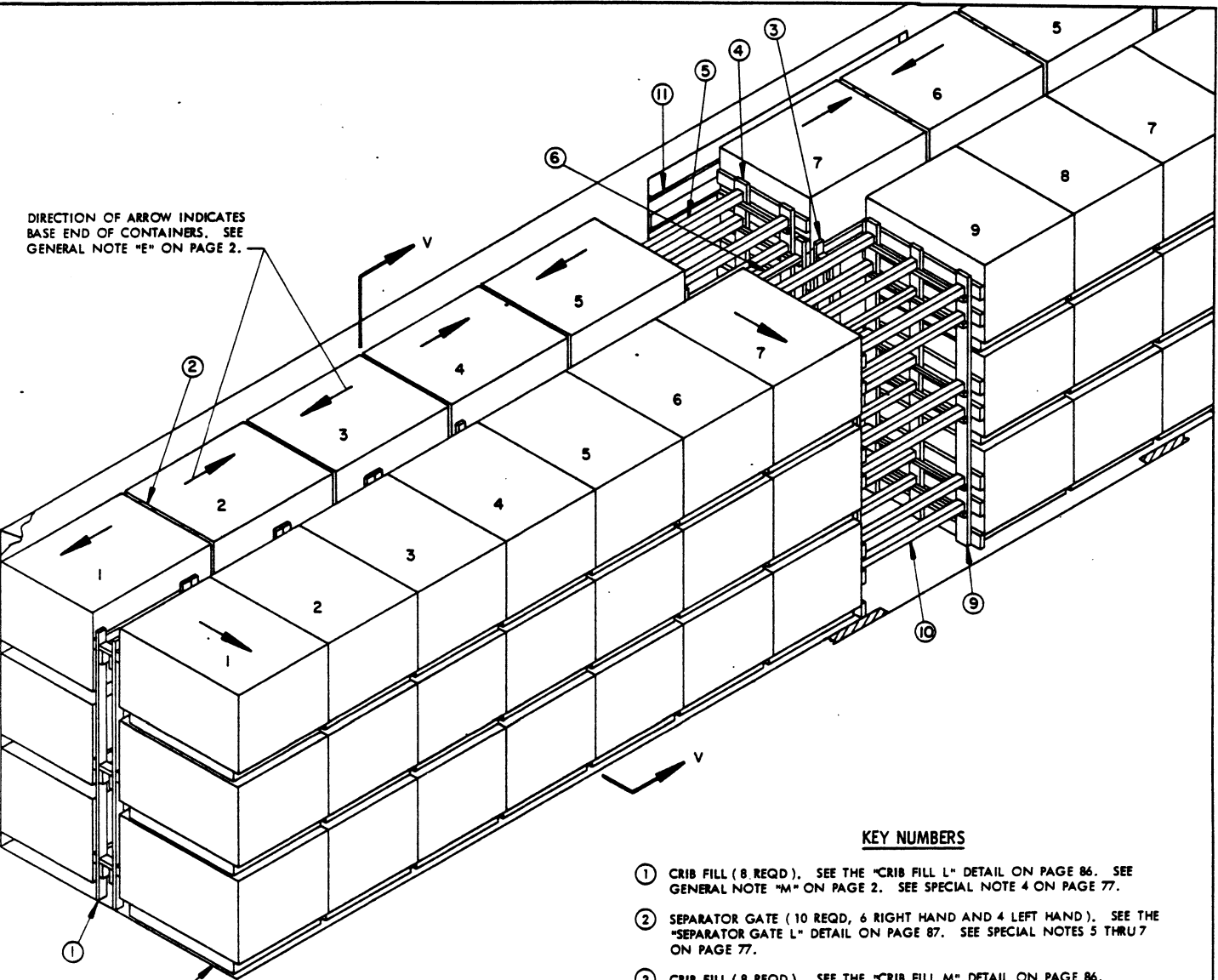

SEE GENERAL NOTE  
"G" ON PAGE 2.

ISOMETRIC VIEW

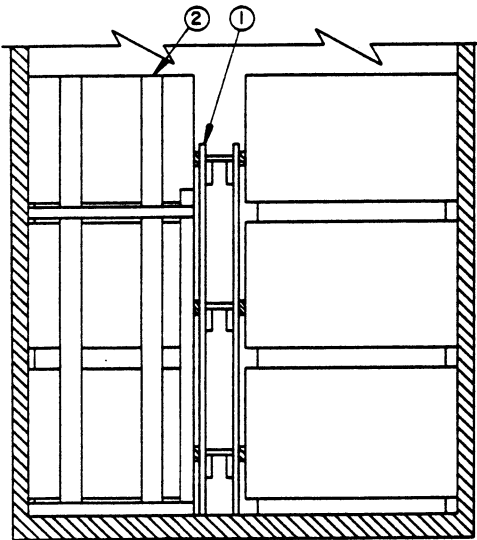

SECTION V-V

**KEY NUMBERS**

- ① CRIB FILL (8 REQD). SEE THE "CRIB FILL L" DETAIL ON PAGE 86. SEE GENERAL NOTE "M" ON PAGE 2. SEE SPECIAL NOTE 4 ON PAGE 77.
- ② SEPARATOR GATE (10 REQD, 6 RIGHT HAND AND 4 LEFT HAND). SEE THE "SEPARATOR GATE L" DETAIL ON PAGE 87. SEE SPECIAL NOTES 5 THRU 7 ON PAGE 77.
- ③ CRIB FILL (8 REQD). SEE THE "CRIB FILL M" DETAIL ON PAGE 86.
- ④ CENTER GATE (2 REQD, 1 RIGHT HAND AND 1 LEFT HAND). SEE THE "CENTER GATE V" DETAIL ON PAGE 86. SEE SPECIAL NOTE 8 ON PAGE 77.
- ⑤ STRUT, 4" X 4" BY CUT TO FIT (REF: 48") (12 REQD). TOENAIL TO PIECES MARKED ④ W/2-16d NAILS AT EACH END. SEE GENERAL NOTES "L", "5" AND "T" ON PAGE 2.
- ⑥ STRUT, 2" X 4" BY CUT TO FIT (REF: 48") (3 REQD). TOENAIL TO THE STOP PIECES OF PIECES MARKED ④ W/2-12d NAILS AT EACH END. SEE THE "PARTIAL PLAN VIEW" ON PAGE 77.
- ⑦ SIDE BLOCKING FOR CENTER GATE "V", 2" X 4" X 18" (DOUBLED) (1 REQD). NAIL THE FIRST PIECE TO THE CAR FLOOR W/4-16d NAILS. NAIL THE SECOND PIECE TO THE FIRST IN A LIKE MANNER. SEE THE "PARTIAL PLAN VIEW" ON PAGE 77.
- ⑧ CRIB FILL RETAINER PIECE, 2" X 4" BY A LENGTH TO SUIT (REF: 72") (2 REQD). POSITION TO SPAN THE STRUTS OF LONGITUDINALLY ADJACENT CRIB FILL "M" ASSEMBLIES AND NAIL TO EACH STRUT W/3-10d NAILS. SEE THE "PARTIAL PLAN VIEW" ON PAGE 77.
- ⑨ CENTER GATE (2 REQD). SEE THE "CENTER GATE W" DETAIL ON PAGE 87.
- ⑩ STRUT, 4" X 4" BY CUT TO FIT (REF: 48") (18 REQD). TOENAIL TO PIECES MARKED ⑨ W/2-16d NAILS AT EACH END.
- ⑪ DOORWAY PROTECTION (2 REQD). SEE THE "DOORWAY PROTECTION K" DETAIL ON PAGE 88. NAIL TO THE DOOR POSTS W/12d NAILS. SEE SPECIAL NOTE 9 ON PAGE 77.

ROUTED DUNNAGE METHOD UNIT (DECREASED HEIGHT)  
84-UNIT LOAD IN A 60'-8" LONG BY 9'-2" WIDE CONVENTIONAL BOX CAR

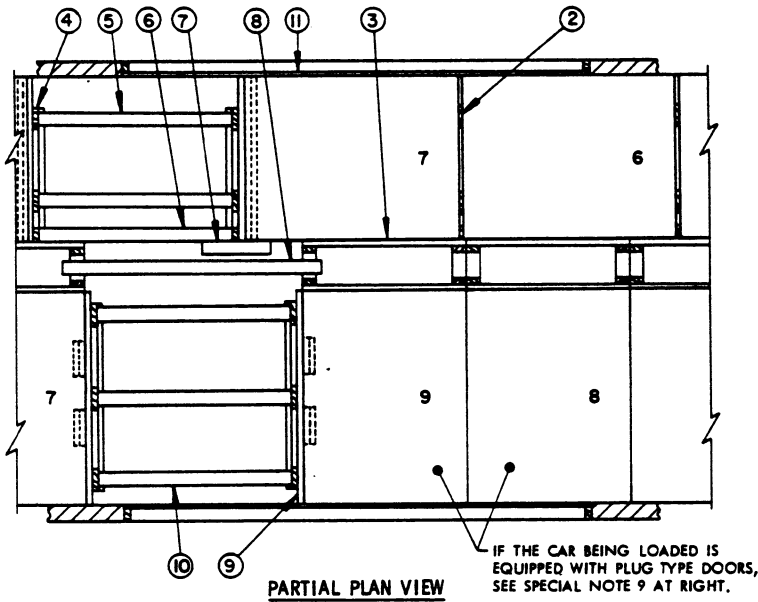

**PARTIAL PLAN VIEW**

( SPECIAL NOTES CONTINUED )

10. THE DEPICTED LOAD CAN BE REDUCED TO SUIT THE QUANTITY TO BE SHIPPED. THE LOAD CAN BE REDUCED BY ONE OR MORE PALLET UNITS BY EMPLOYING THE PROCEDURES SHOWN ON PAGE 96. SIX (6) PALLET UNITS CAN BE OMITTED FROM A 3-TIER LOAD BY LEAVING OUT THE LENGTHWISE STACK NUMBERED 7, THE CROSSWISE STACK NUMBERED 9, AND THE ADJACENT CRIB FILL. NOTE THAT STRUT BRACING MUST BE APPLIED TO ALL THE STRUTS. OR, THE ENTIRE ONE OR TWO TOP TIERS CAN BE OMITTED. A PARTIAL 1-TIER LOAD CAN BE SHIPPED IN ONE OR BOTH ENDS OF A CAR BY USING KNEE BRACES AS SHOWN ON PAGES 112 AND 113.
11. IF PALLETIZED UNITS WHICH DO NOT CONTAIN A FULL QUANTITY OF CONTAINERS ARE TO BE TRANSPORTED, REFER TO PAGE 117 FOR SHIPPING GUIDANCE FOR LENGTHWISE UNITS AND PAGES 118 AND 120 FOR CROSSWISE UNITS.
12. FOR SHIPMENT OF ONE OR MORE LEFTOVER CONTAINERS, SEE THE "PROCEDURES FOR SHIPMENT OF LEFTOVER CONTAINERS" ON PAGE 119 FOR GUIDANCE.

**SPECIAL NOTES:**

1. A 60'-8" LONG BY 9'-2" WIDE WOOD-LINED CONVENTIONAL TYPE BOX CAR EQUIPPED WITH 10'-0" WIDE DOOR OPENINGS IS SHOWN. CARS OF OTHER DIMENSIONS AND CARS HAVING WIDER OR NARROWER DOOR OPENINGS CAN BE USED. SEE GENERAL NOTE "D" ON PAGE 2 AND SPECIAL NOTE 3 BELOW.
2. THE PALLET UNIT SHOWN IN THE TYPICAL LOAD ON PAGE 76 IS THE ROUTED DUNNAGE METHOD UNIT ( DECREASED HEIGHT ). A MAXIMUM OF SIXTY-NINE ( 69 ) OF THESE UNITS, FOR AN APPROXIMATE LADING WEIGHT OF 111,504 POUNDS, CAN BE PLACED IN A 50'-6" LONG CAR WHEN USING THE DEPICTED PROCEDURES; FIFTY-FOUR ( 54 ) UNITS, FOR A LADING WEIGHT OF 87,264 POUNDS, CAN BE OUTLOADED IN A 40'-6" LONG CAR.
3. THE DEPICTED LOAD PATTERN IS ADEQUATE FOR CARS HAVING DOOR OPENINGS AS NARROW AS 7'-0". IF A CAR HAVING DOOR OPENINGS LESS THAN 7'-0" WIDE IS TO BE LOADED, THE LENGTHWISE UNITS SHOULD BE LOADED SIX ( 6 ) STACKS LONG IN EACH END OF THE CAR AND THE CROSSWISE UNITS SHOULD BE LOADED EIGHT ( 8 ) STACKS LONG IN EACH END. AN ADDITIONAL PIECE MARKED ⑦ WILL BE REQUIRED; THE BALANCE OF THE DUNNAGE WILL NOT CHANGE.
4. THE "HIGH" CRIB, SHOWN AS PIECE MARKED ①, MUST BE INSTALLED IN EACH END OF THE LOAD. FOUR ( 4 ) ASSEMBLIES ARE REQUIRED IN EACH END OF A LOAD REGARDLESS OF THE CAR LENGTH.
5. THE SEPARATOR GATES, SHOWN AS PIECES MARKED ② IN THE LOAD ON PAGE 76, ARE DESIGNATED "RIGHT HAND" AND "LEFT HAND" TO FACILITATE POSITIONING OF THE PALLET UNITS AS LOADING PROGRESSES. WHEN LOADING THE CAR, POSITION A PALLET UNIT STACK AGAINST THE END WALL, THEN POSITION A SEPARATOR GATE, SO THE 1" X 4" TIE PIECES ARE LOCATED UNDER THE "OVERHANG" OF THE BOTTOM AND TOP PALLET UNITS. REPEAT THIS PROCEDURE FOR THE REMAINING STACKS.
6. ALL SEPARATOR GATES, PIECES MARKED ②, WHICH ARE WITHIN THE DOORWAY AREA OF A CAR EQUIPPED WITH CONVENTIONAL SLIDING DOORS MUST BE WIRE TIED TO THE ADJACENT CRIB FILL TO PREVENT DISPLACEMENT. ENCIRCLE THE STOP PIECE OF THE SEPARATOR GATE AND THE UPPER HORIZONTAL PIECE OF THE CRIB FILL WITH NO. 14 GAGE WIRE AND TWIST TAUT.
7. SEPARATOR GATES MAY BE FORMED FROM 3/8" OR THICKER PLYWOOD IN LIEU OF DIMENSIONAL LUMBER, IF DESIRED, FOR ONE OR TWO-LAYER LOADS; PLYWOOD SEPARATOR GATES FOR A THREE-LAYER LOAD ARE NOT ECONOMICALLY FEASIBLE. CONSTRUCT EACH SEPARATOR GATE FOR ONE OR TWO-LAYER LOADS FROM 42" WIDE PLYWOOD OF AN APPROPRIATE LENGTH.
8. CENTER GATES "V" AND "W" MAY BE PARTIALLY FORMED FROM 1/2" OR THICKER PLYWOOD, IF DESIRED. PLYWOOD MAY BE USED IN LIEU OF THE 2" X 6" HORIZONTAL PIECES. SEE THE "PLYWOOD CENTER GATE ALTERNATIVE" DETAIL ON PAGE 123 FOR GUIDANCE.
9. DOORWAY PROTECTION IS REQUIRED FOR ALL PALLET UNIT STACKS WHICH ARE COMPLETELY WITHIN THE DOORWAY AREA OR WHICH EXTEND INTO THE DOORWAY AREA BY ONE-HALF OR MORE OF THE STACK WIDTH OR LENGTH. THE WOODEN GATE TYPE OF DOORWAY PROTECTION, SHOWN AS PIECES MARKED ③ IN THE LOAD ON PAGE 76, IS APPLICABLE FOR BOX CARS EQUIPPED WITH CONVENTIONAL SLIDING DOORS AND NAILABLE DOOR POSTS. REFER TO PAGES 126 THRU 128 FOR ALTERNATIVE DOORWAY PROTECTION FOR CARS EQUIPPED WITH CONVENTIONAL SLIDING DOORS. IF THE CAR BEING LOADED IS EQUIPPED WITH PLUG TYPE DOORS, NAILED FLOORLINE BLOCKING AND LOAD-BUNDLING STRAPS MUST BE USED. SEE THE "ALTERNATIVE DOORWAY PROTECTION E" AND "ALTERNATIVE DOORWAY PROTECTION F" DETAILS ON PAGE 128 FOR GUIDANCE; A COMBINATION OF THE TWO METHODS MUST BE USED. NAILED SIDE BLOCKING WILL BE USED UNDER THE CRIB FILL SHOWN IN THE DOORWAY AREA OF THE LOAD. POSITION DOUBLED 2" X 4" X 8'-0" PIECES AGAINST THE LENGTHWISE STACKS NUMBERED 6 AND 7, AND PREPOSITION DOUBLED 2" X 4" X 7'-0" PIECES ( APPROXIMATELY 52" FROM THE NEAR SIDE CAR WALL ) SO AS TO BE AGAINST THE CROSSWISE STACKS NUMBERED 8 AND 9. THESE PIECES WILL BE USED IN LIEU OF THE 40" AND 48" LONG PIECES SHOWN BY THE ALTERNATIVE DETAILS. A SPACER ASSEMBLY, AS SHOWN IN THE "ALTERNATIVE DOORWAY PROTECTION F" DETAIL, MUST BE MODIFIED FOR USE BY CHANGING THE END WHICH EXTENDS OVER THE CROSSWISE CONTAINERS TO BE LIKE THE NEAR END OF THE STRAPPING BOARD SHOWN IN THE "ALTERNATIVE DOORWAY PROTECTION E" DETAIL. A 2" X 4" X 40" DOUBLED BATTEN AS SHOWN IN THAT VIEW IS ALSO REQUIRED. NOTE THAT THE VERTICAL PIECES OF THE CRIB FILL, PIECES MARKED ③, MUST HAVE THREE INCHES ( 3" ) CUT OFF THE BOTTOM END OF ONE SIDE SO THE CRIB WILL REST EVENLY ON THE NAILED SIDE BLOCKING WHICH IS ADJACENT TO THE LENGTHWISE UNITS. ALSO NOTE THAT THE CENTER GATE "V" MUST BE WIRE TIED TO PIECE MARKED ⑧ TO PREVENT DISPLACEMENT.

( CONTINUED AT LEFT )

BILL OF MATERIAL		
LUMBER	LINEAR FEET	BOARD FEET
1" X 4"	140	47
1" X 6"	310	155
2" X 2"	127	43
2" X 3"	44	22
2" X 4"	1106	738
2" X 6"	204	204
4" X 4"	125	167
NAILS	NO. REQD	POUNDS
6d ( 2" )	252	1-1/2
10d ( 3" )	1766	27-1/4
12d ( 3-1/4" )	48	3/4
16d ( 3-1/2" )	128	3
WIRE, NO. 14 GAGE	3' REQD	NIL

**LOAD AS SHOWN**

ITEM	QUANTITY	WEIGHT ( APPROX )
PALLET UNIT	84	135,744 LBS
DUNNAGE		2,785 LBS
<b>TOTAL WEIGHT</b>		<b>138,529 LBS</b>

ROUTED DUNNAGE METHOD UNIT ( DECREASED HEIGHT )  
84- UNIT LOAD IN A 60'-8" LONG BY 9'-2" WIDE CONVENTIONAL BOX CAR

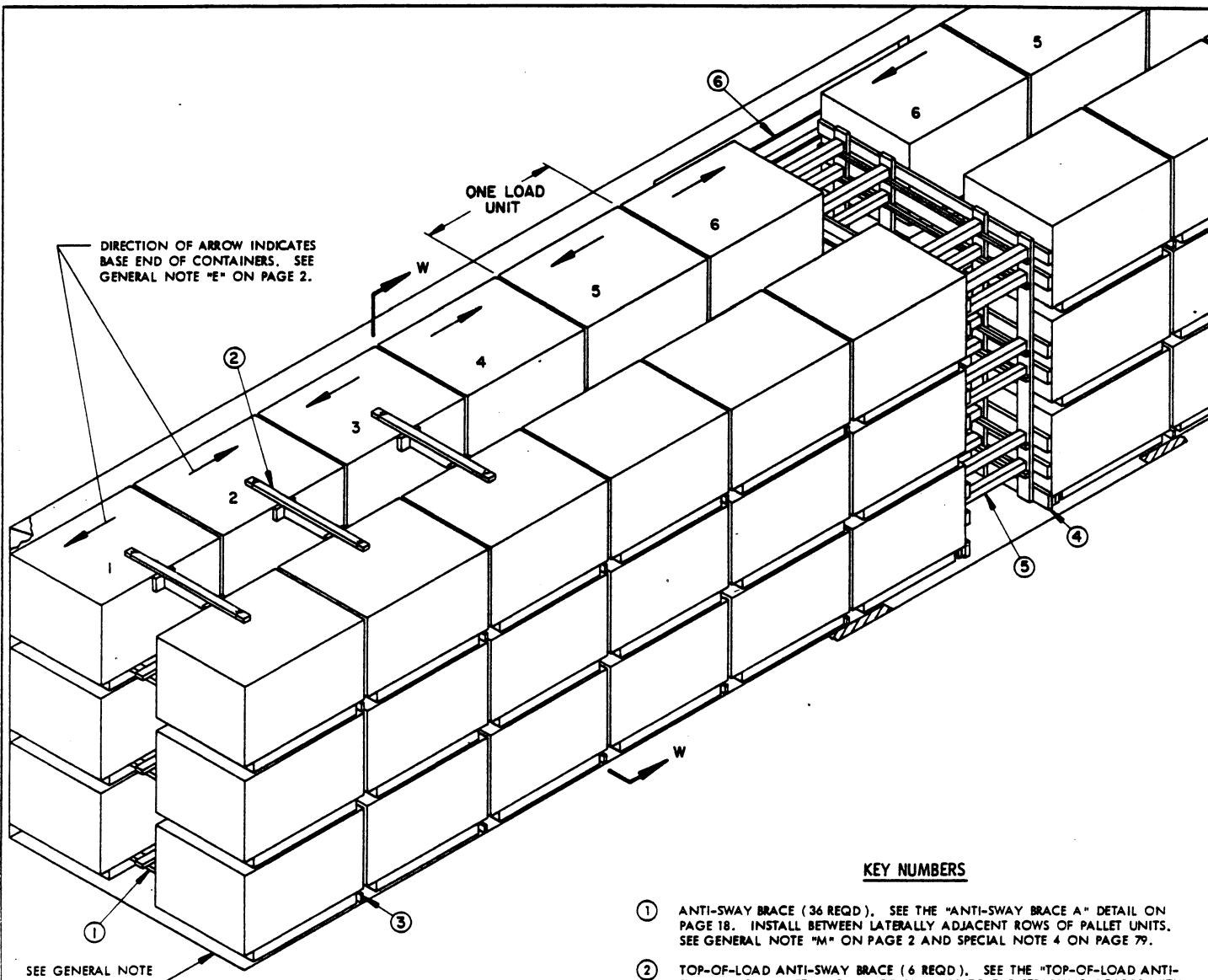

DIRECTION OF ARROW INDICATES  
BASE END OF CONTAINERS. SEE  
GENERAL NOTE "E" ON PAGE 2.

SEE GENERAL NOTE  
"G" ON PAGE 2.

**ISOMETRIC VIEW**

**KEY NUMBERS**

- ① ANTI-SWAY BRACE (36 REQD). SEE THE "ANTI-SWAY BRACE A" DETAIL ON PAGE 18. INSTALL BETWEEN LATERALLY ADJACENT ROWS OF PALLET UNITS. SEE GENERAL NOTE "M" ON PAGE 2 AND SPECIAL NOTE 4 ON PAGE 79.
- ② TOP-OF-LOAD ANTI-SWAY BRACE (6 REQD). SEE THE "TOP-OF-LOAD ANTI-SWAY BRACE B" DETAIL ON PAGE 46. WIRE TO THE STRAPPING BOARDS WITH NO. 14 GAGE WIRE AS TYPICALLY SHOWN BY THE "TIE WIRE APPLICATION B" DETAIL ON PAGE 122. SEE SPECIAL NOTE 5 ON PAGE 79.
- ③ SEPARATOR GATE (10 REQD). SEE THE "SEPARATOR GATE M" DETAIL ON PAGE 87. POSITION WITH THE HORIZONTAL PIECES AGAINST THE ALREADY-LOADED UNITS. SEE SPECIAL NOTES 6 THRU 8 ON PAGE 79.
- ④ CENTER GATE (2 REQD). SEE THE "CENTER GATE X" DETAIL ON PAGE 88. SEE SPECIAL NOTES 9, 10, AND 13 ON PAGE 79.
- ⑤ STRUT, 4" X 4" BY CUT TO FIT (REF. 48") (24 REQD). TOENAIL TO PIECES MARKED ④ W/2-16d NAILS AT EACH END. SEE GENERAL NOTES "L", "5", AND "T" ON PAGE 2.
- ⑥ DOORWAY PROTECTION (2 REQD). SEE THE "DOORWAY PROTECTION K" DETAIL ON PAGE 88. SEE SPECIAL NOTE 12 ON PAGE 79.

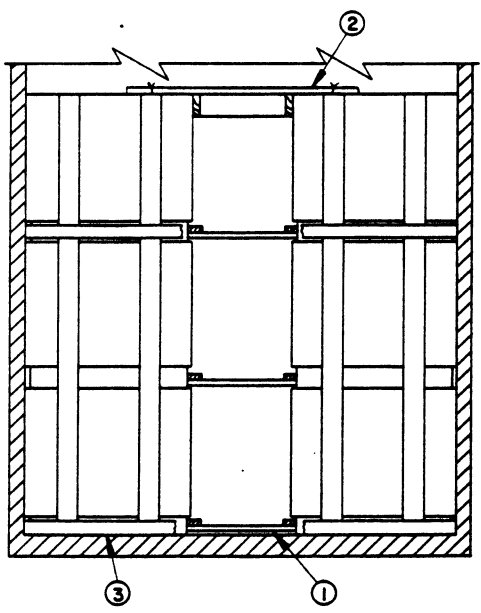

**SECTION W-W**

**ROUTED DUNNAGE METHOD UNIT (DECREASED HEIGHT)  
72-UNIT LOAD IN A 60'-8" LONG BY 9'-2" WIDE CONVENTIONAL BOX CAR**

( SPECIAL NOTES CONTINUED )

13. IF THE "ALTERNATIVE DOORWAY PROTECTION F" PROCEDURES SHOWN ON PAGE 128 ARE USED IN LIEU OF THE WOODEN DOORWAY PROTECTION, PIECES MARKED (A), THE CENTER GATES MUST BE RESTRAINED FROM LATERAL MOVEMENT. THIS CAN BE ACCOMPLISHED BY NAILING TO THE CAR FLOOR A DOUBLED 2" X 4" X 18" PIECE POSITIONED LONGITUDINALLY SO AS TO BE CENTERED AGAINST THE FILL PIECE OF A CENTER GATE. TWO (2) PIECES WILL BE REQUIRED FOR EACH CENTER GATE WHICH IS IN THE DOOR OPENING OR WITHIN SIX INCHES (6") OF BEING IN THE OPENING.
14. THE DEPICTED LOAD CAN BE REDUCED TO SUIT THE QUANTITY TO BE SHIPPED. A 3-TIER LOAD CAN BE REDUCED BY A MULTIPLE OF SIX (6) PALLET UNITS, OR A 2-TIER LOAD CAN BE REDUCED BY A MULTIPLE OF FOUR (4) UNITS, OR A 1-TIER LOAD CAN BE REDUCED BY A MULTIPLE OF TWO (2) UNITS BY OMITTING ONE OR MORE LOAD UNITS FROM THE CENTER PORTION OF THE LOAD. OR, THE ENTIRE ONE OR TWO TOP TIERS CAN BE OMITTED. FOR OTHER METHODS OF REDUCING A LOAD, AND FOR TYPICAL LCL PROCEDURES, REFER TO PAGES 92 THRU 120 FOR GUIDANCE.
15. IF PALLETIZED UNITS WHICH DO NOT CONTAIN A FULL QUANTITY OF CONTAINERS ARE TO BE TRANSPORTED, REFER TO PAGE 117 FOR SHIPPING GUIDANCE.
16. FOR SHIPMENT OF ONE OR MORE LEFTOVER CONTAINERS, SEE THE "PROCEDURES FOR SHIPMENT OF LEFTOVER CONTAINERS" ON PAGE 119 FOR GUIDANCE.

**SPECIAL NOTES:**

1. A 60'-8" LONG BY 9'-2" WIDE WOOD-LINED CONVENTIONAL TYPE BOX CAR EQUIPPED WITH 10'-0" WIDE DOOR OPENINGS IS SHOWN. CARS OF OTHER DIMENSIONS AND CARS HAVING WIDER OR NARROWER DOOR OPENINGS CAN BE USED. SEE GENERAL NOTE "D" ON PAGE 2 AND SPECIAL NOTE 3 BELOW.
2. THE PALLET UNIT SHOWN IN THE TYPICAL LOAD ON PAGE 78 IS THE ROUTED DUNNAGE METHOD UNIT ( DECREASED HEIGHT ). A MAXIMUM OF SIXTY (60) OF THESE UNITS, FOR AN APPROXIMATE LADING WEIGHT OF 96,960 POUNDS, CAN BE PLACED IN A 50'-6" LONG CAR WHEN USING THE DEPICTED PROCEDURES; FORTY-EIGHT (48) UNITS, FOR AN APPROXIMATE LADING WEIGHT OF 77,568 POUNDS, CAN BE OUTLOADED IN A 40'-6" LONG CAR.
3. THE DEPICTED LOADING PATTERN IS ADEQUATE FOR CARS HAVING ANY SIZE DOORS. HOWEVER, IF THE CAR TO BE LOADED HAS DOOR OPENINGS AT LEAST 8'-0" WIDE AND OF SUFFICIENT HEIGHT TO ALLOW PERSONNEL TO EXIT THE CAR OVER THE TOP OF THE LOAD, WHEN NECESSARY, LOADING AND UNLOADING WILL BE EASIER IF THE PALLETS ARE POSITIONED SO THERE ARE SEVEN (7) LOAD UNITS IN ONE END OF THE CAR AND FIVE (5) LOAD UNITS IN THE OPPOSITE.
4. IF THE "ALTERNATIVE DOORWAY PROTECTION F" PROCEDURES AS SHOWN ON PAGE 128 ARE USED IN LIEU OF THE WOODEN DOOR GATE TYPE PROTECTION, PIECE MARKED (A), NAILED FLOORLINE BLOCKING MUST BE USED IN LIEU OF EACH LOWER ANTI-SWAY BRACE IN THE DOORWAY AREA. NAILED BLOCKING IS REQUIRED FOR ALL PALLET STACKS WHICH ARE COMPLETELY WITHIN THE DOORWAY AREA OR WHICH EXTEND INTO THE DOORWAY AREA BY ONE-HALF OR MORE OF THE STACK WIDTH ON EITHER SIDE OF THE CAR.
5. TOP-OF-LOAD ANTI-SWAY BRACES, SHOWN AS PIECES MARKED (B) IN THE LOAD ON PAGE 78, MUST BE INSTALLED IN EACH END OF THE CAR AND WIRE TIED TO A STRAPPING BOARD WITH NO. 14 GAGE WIRE AS SHOWN. THREE (3) BRACES ARE REQUIRED IN EACH END OF A LOAD REGARDLESS OF THE CAR LENGTH.
6. TO FACILITATE POSITIONING OF THE PALLET UNITS AS LOADING PROGRESSES, WHEN LOADING THE BOX CAR, POSITION PALLET UNIT STACKS AGAINST THE END WALL, THEN POSITION A SEPARATOR GATE, SHOWN AS PIECE MARKED (C), SO THE 1" X 4" TIE PIECES ARE LOCATED UNDER THE "OVERHANG" OF THE BOTTOM AND TOP PALLET UNITS. REPEAT THIS PROCEDURE FOR THE REMAINING STACKS.
7. SEPARATOR GATES IN THE DOORWAY MUST BE PREVENTED FROM SHIFTING INTO A DOOR OPENING BY THE APPLICATION OF STOP PIECES. A 7'-0" LONG STOP PIECE IS REQUIRED FOR A 3-LAYER LOAD AND 48" LONG STOP PIECES ARE REQUIRED FOR 1 AND 2-LAYER LOADS. SEE PIECE MARKED (D) ON PAGE 64 FOR A TYPICAL INSTALLATION. IN CARS EQUIPPED WITH STAGGERED DOORS, STOP PIECES MAY BE REQUIRED ON UP TO FOUR SEPARATOR GATES.
8. SEPARATOR GATES MAY BE FORMED FROM 3/8" OR THICKER PLYWOOD IN LIEU OF DIMENSIONAL LUMBER, IF DESIRED, FOR ONE OR TWO-LAYER LOADS; PLYWOOD SEPARATOR GATES FOR 3-HIGH LOADS ARE NOT ECONOMICALLY FEASIBLE. SEE THE "ALTERNATIVE SEPARATOR GATE" DETAIL ON PAGE 122 FOR CONSTRUCTION GUIDANCE.
9. CENTER GATE "X" MAY BE PARTIALLY FORMED FROM 1/2" OR THICKER PLYWOOD, IF DESIRED. PLYWOOD MAY BE USED IN LIEU OF THE 2" X 6" HORIZONTAL PIECES. SEE THE "PLYWOOD CENTER GATE ALTERNATIVE" DETAIL ON PAGE 123 FOR GUIDANCE.
10. FOR EASE OF HANDLING, SPLIT CENTER GATES, WHICH ARE NOT DEPENDENT UPON THE WIDTH OF THE CAR, MAY BE USED AS AN ALTERNATIVE TO THE CAR-WIDTH GATES. IN LIEU OF EACH "CENTER GATE X", SHOWN AS PIECE MARKED (E) IN THE LOAD ON PAGE 78, INSTALL TWO (2) "CENTER GATES V" AS SHOWN ON PAGE 86. AFTER THE SPLIT GATES AND STRUTS HAVE BEEN INSTALLED, THE SPLIT GATES MUST BE TIED TOGETHER AS DEPICTED BY THE "TIE PIECE APPLICATION" DETAIL ON PAGE 123. OMIT THE STOP PIECES FROM "CENTER GATE V".
11. DOOR SPANNER TYPE GATE HOLD DOWN MAY BE USED IN LIEU OF THE DOUBLED 2" X 4" MATERIAL NAILED TO CENTER GATE "L", PROVIDING THE CAR BEING LOADED HAS NAILABLE SIDEWALLS. SEE THE DETAILS ON PAGE 125 FOR GUIDANCE.
12. DOORWAY PROTECTION IS REQUIRED FOR ALL PALLET UNIT STACKS WHICH ARE COMPLETELY WITHIN THE DOORWAY AREA OR WHICH EXTEND INTO THE DOORWAY AREA BY ONE-HALF OR MORE OF THE STACK WIDTH. THE WOODEN GATE TYPE OF DOORWAY PROTECTION, SHOWN AS PIECES MARKED (F) IN THE LOAD ON PAGE 78, IS APPLICABLE FOR BOX CARS EQUIPPED WITH CONVENTIONAL SLIDING DOORS AND NAILABLE DOOR POSTS. REFER TO PAGES 126 THRU 128 FOR ALTERNATIVE DOORWAY PROTECTION FOR CARS EQUIPPED WITH CONVENTIONAL SLIDING DOORS. IF THE CAR BEING LOADED IS EQUIPPED WITH PLUG TYPE DOORS, NAILED FLOORLINE BLOCKING AND LOAD BUNDLING STRAPS MUST BE USED. SEE THE "ALTERNATIVE DOORWAY PROTECTION F" DETAIL ON PAGE 128 FOR GUIDANCE.

( CONTINUED AT LEFT )

**LOAD AS SHOWN**

ITEM	QUANTITY	WEIGHT ( APPROX )
PALLET UNIT -----	72 -----	116,352 LBS
DUNNAGE -----		2,141 LBS
TOTAL WEIGHT -----		118,493 LBS

BILL OF MATERIAL		
LUMBER	LINEAR FEET	BOARD FEET
1" X 4"	183	61
1" X 6"	500	250
2" X 2"	110	37
2" X 3"	36	18
2" X 4"	515	344
2" X 6"	217	217
4" X 4"	100	134
NAILS	NO. REQD	POUNDS
6d (2")	312	2
10d (3")	820	12-3/4
12d (3-1/4")	36	3/4
16d (3-1/2")	96	2-1/4
WIRE, NO. 14 GAGE ----- 60' REQD ----- 1 LB		

ROUTED DUNNAGE METHOD UNIT ( DECREASED HEIGHT )  
72-UNIT LOAD IN A 60'-8" LONG BY 9'-2" WIDE CONVENTIONAL BOX CAR

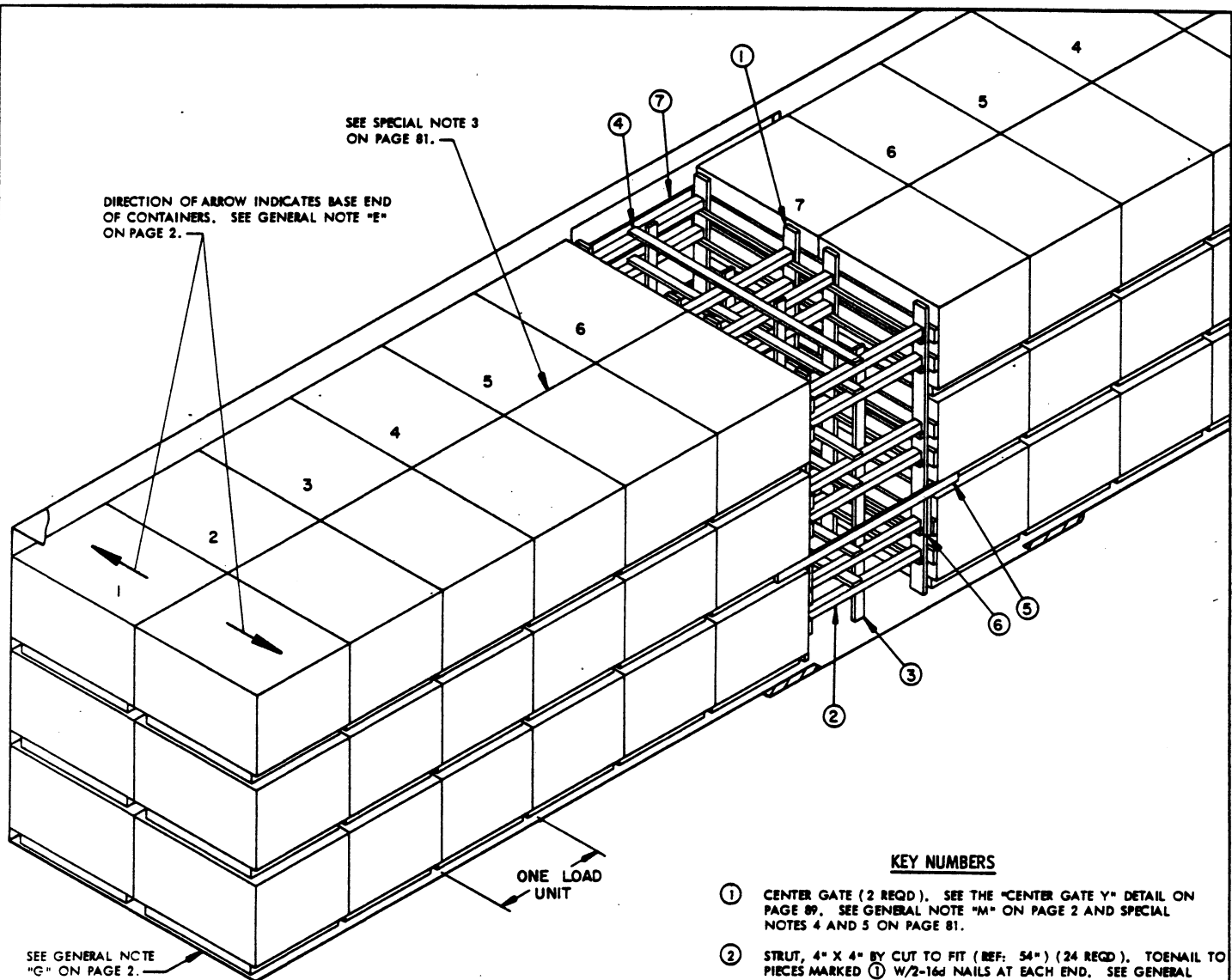

**ISOMETRIC VIEW**

**KEY NUMBERS**

- ① CENTER GATE (2 REQD). SEE THE "CENTER GATE Y" DETAIL ON PAGE 89. SEE GENERAL NOTE "M" ON PAGE 2 AND SPECIAL NOTES 4 AND 5 ON PAGE 81.
- ② STRUT, 4" X 4" BY CUT TO FIT (REF: 54") (24 REQD). TOENAIL TO PIECES MARKED ① W/2-16d NAILS AT EACH END. SEE GENERAL NOTES "L" AND "T" ON PAGE 2.
- ③ VERTICAL STRUT BRACING, 2" X 4" X 9'-0" (4 REQD). NAIL TO THE STRUTS W/3-10d NAILS AT EACH JOINT.
- ④ HORIZONTAL STRUT BRACING, 2" X 4" BY CAR WIDTH MINUS 5" (6 REQD). NAIL TO THE STRUTS W/3-10d NAILS AT EACH JOINT.
- ⑤ GATE HOLD DOWN, 2" X 4" BY LENGTH OF CENTER VOID PLUS .24" (REF: 7'-40") (2 REQD). NAIL TO THE VERTICAL PIECES OF THE CENTER GATES W/2-10d NAILS AT EACH JOINT. SEE SPECIAL NOTE 6 ON PAGE 81.
- ⑥ GATE HOLD DOWN SUPPORT PIECE, 2" X 2" X 15" (4 REQD). POSITION UNDER PIECE MARKED ⑤ AND NAIL TO A VERTICAL PIECE OF PIECE MARKED ① W/4-10d NAILS.
- ⑦ DOORWAY PROTECTION (2 REQD). SEE THE "DOORWAY PROTECTION R" DETAIL ON PAGE 88. SEE SPECIAL NOTE 7 ON PAGE 81.

**ROUTED DUNNAGE METHOD UNIT (DECREASED HEIGHT)  
78-UNIT LOAD IN A 50'-6" LONG BY 9'-4" WIDE CONVENTIONAL BOX CAR**



**SPECIAL NOTES:**

1. A 50'-6" LONG BY 9'-4" WIDE WOOD-LINED CONVENTIONAL TYPE BOX CAR EQUIPPED WITH 8'-0" WIDE DOOR OPENINGS IS SHOWN. WIDER CARS OF OTHER LENGTHS AND CARS HAVING WIDER OR NARROWER DOOR OPENINGS CAN BE USED. SEE GENERAL NOTE "D" ON PAGE 2.
2. THE PALLETIZED UNIT SHOWN IN THE TYPICAL LOAD ON PAGE 80 IS THE ROUTED DUNNAGE METHOD UNIT ( DECREASED HEIGHT ). A MAXIMUM OF SIXTY ( 60 ) OF THESE UNITS, FOR AN APPROXIMATE LADING WEIGHT OF 96,960 POUNDS, CAN BE PLACED IN A 40'-6" LONG CAR WHEN USING THE DEPICTED PROCEDURES. IF A 60'-8" LONG BY 9'-4" OR WIDER CAR IS AVAILABLE, NINETY-SIX ( 96 ) PALLET UNITS, FOR AN APPROXIMATE LADING WEIGHT OF 155,136 POUNDS, CAN BE LOADED. SEE SPECIAL NOTE 9 FOR CENTER GATE MODIFICATIONS WHICH MUST BE MADE IF 60' LONG CARS ARE TO BE USED.
3. ANTI-SWAY BRACING BETWEEN LATERALLY ADJACENT ROWS OF PALLET UNITS IS REQUIRED IF A CAR WHICH IS WIDER THAN 9'-4" IS FURNISHED FOR LOADING. SEE THE "ANTI-SWAY BRACE B" DETAIL ON PAGE 74 FOR CONSTRUCTION GUIDANCE. TO PREVENT LONGITUDINAL DISPLACEMENT OF THE ANTI-SWAY BRACE BETWEEN THE UPPER UNITS, A STOP PIECE MUST BE NAILED TO EACH CENTER GATE "Y" AS SHOWN ON THE DETAIL ON PAGE 89. TO PREVENT DISPLACEMENT OF THE FLOORLINE ANTI-SWAY BRACE ( IF USED ), POSITION A DOUBLED 2" X 4" X 12" PIECE LONGITUDINALLY BETWEEN THE FILL PIECES ON THE GATE SO AS TO BE IN CONTACT WITH THE ANTI-SWAY BRACE AND NAIL TO THE CAR FLOOR W/3-12d NAILS EACH LAYER. IF DESIRED IN CARS HAVING NAILABLE SIDEWALLS, 1" X 6" OR 2" X 6" FILL MATERIAL MAY BE NAILED TO ONE OR BOTH SIDEWALLS AT HEIGHTS SPECIFIED FOR THE DOORWAY PROTECTION HORIZONTAL PIECES, IN LIEU OF USING THE ANTI-SWAY BRACES. ( NOTE THAT THE TOTAL ACCUMULATED SPACE ACROSS A CAR SHOULD NOT EXCEED TWO INCHES ( 2" ) ).
4. CENTER GATE "Y" MAY BE PARTIALLY FORMED FROM 1/2" OR THICKER PLYWOOD, IF DESIRED. PLYWOOD MAY BE USED IN LIEU OF THE 2" X 6" HORIZONTAL PIECES. SEE THE "PLYWOOD CENTER GATE ALTERNATIVE" DETAIL ON PAGE 123 FOR GUIDANCE.
5. FOR EASE OF HANDLING, SPLIT CENTER GATES, WHICH ARE NOT DEPENDENT UPON THE WIDTH OF THE CAR, MAY BE USED AS AN ALTERNATIVE TO THE CAR-WIDTH GATES. IN LIEU OF EACH "CENTER GATE Y", SHOWN AS PIECE MARKED ① IN THE LOAD ON PAGE 80, INSTALL TWO ( 2 ) "CENTER GATES W" AS SHOWN ON PAGE 87. AFTER THE SPLIT GATES AND STRUTS HAVE BEEN INSTALLED, THE SPLIT GATES MUST BE TIED TOGETHER AS DEPICTED BY THE "TIE PIECE APPLICATION" DETAIL ON PAGE 123.
6. AN ALTERNATIVE TO THE GATE HOLD DOWN SHOWN AS PIECE MARKED ⑤ IN THE LOAD ON PAGE 80 MAY BE USED, IF DESIRED, WHEN THE CAR FURNISHED FOR LOADING IS EQUIPPED WITH 8'-0" OR WIDER DOORS. NOTE THAT IN A CAR HAVING DOOR OPENINGS JUST 8'-0" WIDE IT MAY BE NECESSARY TO LAMINATE ONE OR TWO THICKNESSES OF 2-INCH MATERIAL TO THE ADJACENT CENTER GATE VERTICAL PIECES TO PROVIDE AN AREA FOR NAILING OF PIECES MARKED ⑤ AND ⑥. AN ALTERNATIVE MUST BE USED WHEN THE CAR FURNISHED HAS DOOR OPENINGS LESS THAN 8'-0" WIDE. DOOR SPANNER TYPE HOLD DOWN AS SHOWN ON PAGE 125 MAY BE USED IF THE CAR HAS NAILABLE SIDEWALLS, OR DOUBLED 2" X 3" HOLD DOWN PIECES MAY BE APPLIED TO THE CENTER GATES AS SHOWN BY THE CENTER GATE "Y" DETAIL ON PAGE 89.
7. DOORWAY PROTECTION IS REQUIRED FOR ALL PALLET UNIT STACKS WHICH ARE COMPLETELY WITHIN THE DOORWAY AREA OR WHICH EXTEND INTO THE DOORWAY AREA BY ONE-HALF OR MORE OF THE STACK LENGTH. THE WOODEN GATE TYPE OF DOORWAY PROTECTION, SHOWN AS PIECES MARKED ⑦ IN THE LOAD ON PAGE 80, IS APPLICABLE FOR BOX CARS EQUIPPED WITH CONVENTIONAL SLIDING DOORS AND NAILABLE DOOR POSTS. REFER TO PAGES 126 THRU 128 FOR ALTERNATIVE DOORWAY PROTECTION FOR CARS EQUIPPED WITH CONVENTIONAL SLIDING DOORS. IF THE CAR BEING LOADED IS EQUIPPED WITH PLUG TYPE DOORS, NAILED FLOORLINE BLOCKING AND LOAD BUNDLING STRAPS MUST BE USED. SEE THE "ALTERNATIVE DOORWAY PROTECTION E" DETAIL ON PAGE 128 FOR GUIDANCE.
8. THE DEPICTED LOAD CAN BE REDUCED TO SUIT THE QUANTITY TO BE SHIPPED. A 3-TIER LOAD CAN BE REDUCED BY A MULTIPLE OF SIX ( 6 ) PALLET UNITS, A 2-TIER LOAD CAN BE REDUCED BY A MULTIPLE OF FOUR ( 4 ) UNITS, OR A 1-TIER LOAD CAN BE REDUCED BY A MULTIPLE OF TWO ( 2 ) UNITS BY OMITTING ONE OR MORE LOAD UNITS FROM THE CENTER PORTION OF THE LOAD. OR, THE ENTIRE ONE OR TWO TOP TIERS CAN BE OMITTED. FOR OTHER METHODS OF REDUCING A LOAD, AND FOR TYPICAL LCL PROCEDURES, REFER TO PAGES 92 THRU 120 FOR GUIDANCE.
9. IF A FULL LOAD IS TO BE SHIPPED IN A 60' LONG CAR, SIX ( 6 ) STRUTS ARE REQUIRED FOR EACH ROW/TIER. TO ACCOMMODATE THESE ADDITIONAL STRUTS, A VERTICAL PIECE MUST BE ADDED TO CENTER GATE "Y" FOR EACH ROW AS SHOWN BY THE PHANTOMED LINES ON THE DETAIL ON PAGE 89.
10. IF PALLET UNITS WHICH DO NOT CONTAIN A FULL QUANTITY OF CONTAINERS ARE TO BE TRANSPORTED, REFER TO PAGES 118 AND 120 FOR SHIPPING GUIDANCE.
11. FOR SHIPMENT OF ONE OR MORE LEFTOVER CONTAINERS, SEE THE "PROCEDURES FOR SHIPMENT OF LEFTOVER CONTAINERS" ON PAGE 119 FOR GUIDANCE.

BILL OF MATERIAL		
LUMBER	LINEAR FEET	BOARD FEET
1" X 6"	96	48
2" X 2"	117	39
2" X 3"	36	18
2" X 4"	104	70
2" X 6"	201	201
4" X 4"	108	144
NAILS	NO. REQD	POUNDS
6d ( 2" )	72	1/2
10d ( 3" )	336	5-1/4
12d ( 3-1/4" )	36	3/4
16d ( 3-1/2" )	96	2-1/4

**LOAD AS SHOWN**

ITEM	QUANTITY	WEIGHT ( APPROX )
PALLET UNIT	78	126,048 LBS
DUNNAGE		1,049 LBS
TOTAL WEIGHT		127,097 LBS

ROUTED DUNNAGE METHOD UNIT ( DECREASED HEIGHT )  
78-UNIT LOAD IN A 50'-6" LONG BY 9'-4" WIDE CONVENTIONAL BOX CAR

**CAR EQUIPMENT REQUIRED**

ADJUSTABLE WALL MEMBER -----	32
(SEE "NOTE 1" BELOW)	
CROSS MEMBER -----	28
DOORWAY MEMBER -----	8

NOTE 1: FOR CARS EQUIPPED WITH FIXED WALL MEMBERS LOCATED AT THE HEIGHTS SPECIFIED IN "SECTION X-X"; OMIT ALL REFERENCE TO "ADJUSTABLE WALL MEMBERS".

DIRECTION OF ARROW INDICATES BASE END OF CONTAINERS. SEE GENERAL NOTE "E" ON PAGE 2.

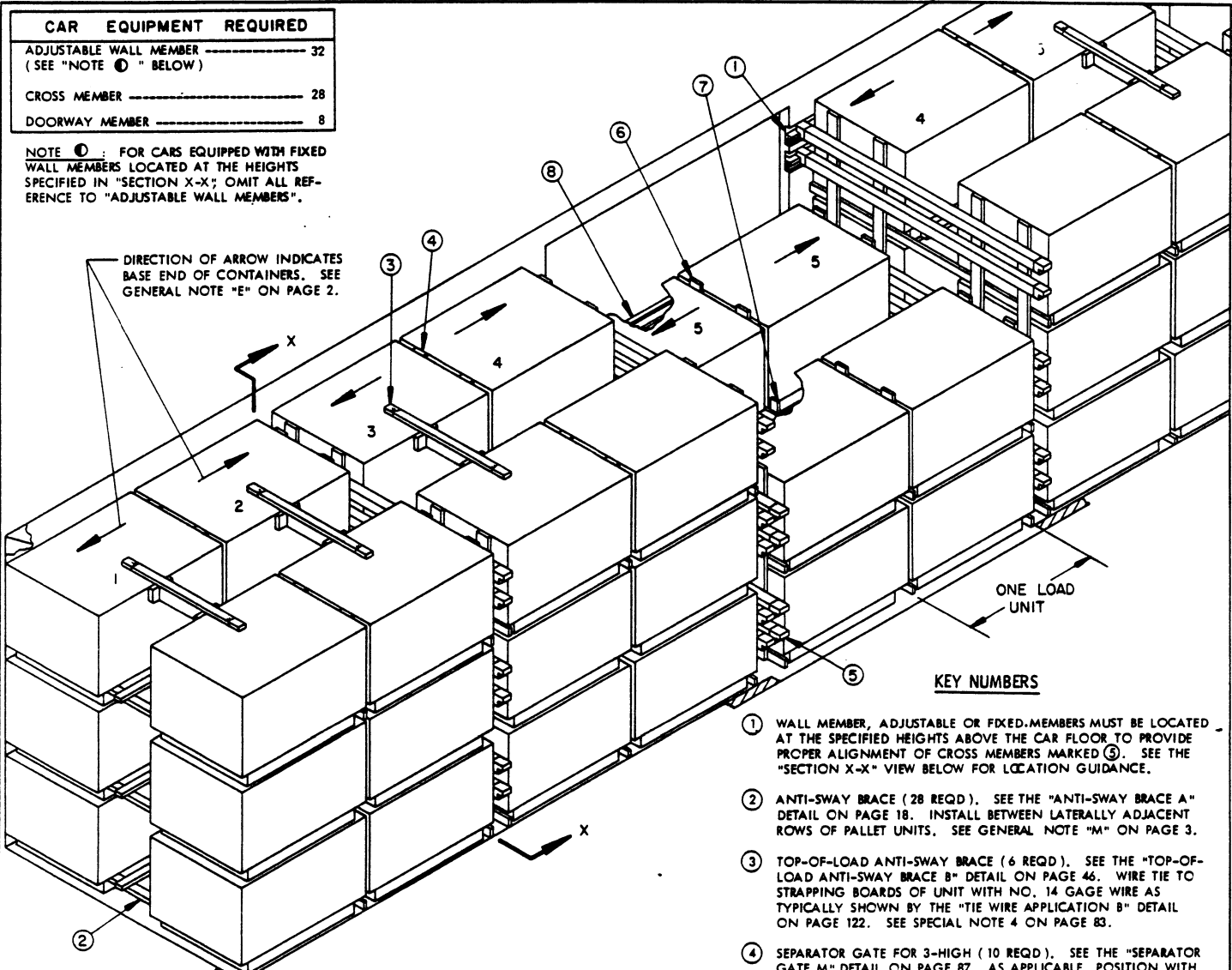

**ISOMETRIC VIEW**

SEE GENERAL NOTES "D" AND "G" ON PAGE 2 AND SPECIAL NOTE 3 ON PAGE 83.

EACH DIMENSIONED HEIGHT ABOVE THE CAR FLOOR TO AN ADJUSTABLE OR FIXED WALL MEMBER MARKED 1 AND/OR A DOORWAY MEMBER MARKED 8 IS SPECIFIED TO LOCATE THE CENTER LINE OF A CROSS MEMBER.

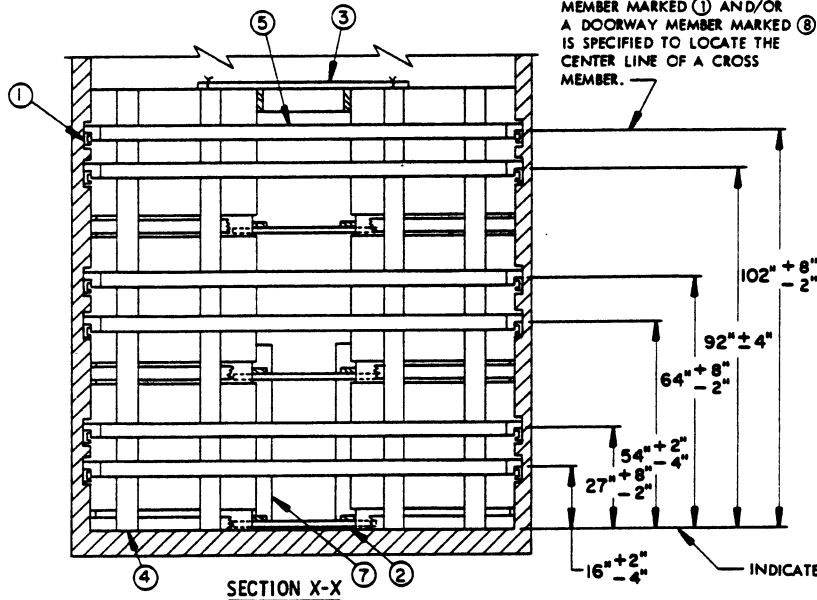

**SECTION X-X**

INDICATES CAR FLOOR.

**KEY NUMBERS**

- 1 WALL MEMBER, ADJUSTABLE OR FIXED. MEMBERS MUST BE LOCATED AT THE SPECIFIED HEIGHTS ABOVE THE CAR FLOOR TO PROVIDE PROPER ALIGNMENT OF CROSS MEMBERS MARKED 5. SEE THE "SECTION X-X" VIEW BELOW FOR LOCATION GUIDANCE.
- 2 ANTI-SWAY BRACE (28 REQD.). SEE THE "ANTI-SWAY BRACE A" DETAIL ON PAGE 18. INSTALL BETWEEN LATERALLY ADJACENT ROWS OF PALLET UNITS. SEE GENERAL NOTE "M" ON PAGE 3.
- 3 TOP-OF-LOAD ANTI-SWAY BRACE (6 REQD.). SEE THE "TOP-OF-LOAD ANTI-SWAY BRACE B" DETAIL ON PAGE 46. WIRE TIE TO STRAPPING BOARDS OF UNIT WITH NO. 14 GAGE WIRE AS TYPICALLY SHOWN BY THE "TIE WIRE APPLICATION B" DETAIL ON PAGE 122. SEE SPECIAL NOTE 4 ON PAGE 83.
- 4 SEPARATOR GATE FOR 3-HIGH (10 REQD.). SEE THE "SEPARATOR GATE M" DETAIL ON PAGE 87. AS APPLICABLE, POSITION WITH THE HORIZONTAL PIECES AGAINST THE ALREADY-LOADED UNITS. SEE SPECIAL NOTES 5 AND 7 ON PAGE 83.
- 5 CROSS MEMBER (28 REQD.). SEE GENERAL NOTE "W" ON PAGE 3.
- 6 SEPARATOR GATE FOR 2-HIGH (3 REQD.). SEE THE "SEPARATOR GATE M" DETAIL ON PAGE 87. AS APPLICABLE, POSITION WITH THE HORIZONTAL PIECES AGAINST THE ALREADY-LOADED UNITS. SEE SPECIAL NOTES 5 THRU 7 ON PAGE 83.
- 7 STOP PIECE, 1" X 4" X 48" (4 REQD.). POSITION AGAINST PALLET UNITS IN THE DOORWAY AND JAIL TO THE HORIZONTAL PIECES ON PIECE MARKED 6 W/3-6d NAILS AT EACH JOINT AND CLINCH. SEE SPECIAL NOTE 6 ON PAGE 83.
- 8 DOORWAY MEMBER (8 REQD.). SEE THE "SECTION X-X" VIEW AT LEFT FOR PROPER LOCATION GUIDANCE. SEE SPECIAL NOTE 8 ON PAGE 83.

**ROUTED DUNNAGE METHOD UNIT (DECREASED HEIGHT)**

**56-UNIT LOAD IN A 50'-8" LONG BY 9'-0" WIDE BOX CAR EQUIPPED WITH MECHANICAL BRACING DEVICES**

**SPECIAL NOTES:**

1. A 50'-6" LONG BY 9'-0" WIDE ( INSIDE CLEARANCE ) BOX CAR EQUIPPED WITH ADJUSTABLE AND/OR FIXED WALL MEMBERS, AND WITH 10'-0" WIDE DOOR OPENINGS, IS SHOWN. CARS OF OTHER DIMENSIONS AND CARS HAVING WIDER OR NARROWER DOOR OPENINGS CAN BE USED.
2. THE PALLETIZED UNIT SHOWN IN THE TYPICAL LOAD ON PAGE 82 IS THE ROUTED DUNNAGE METHOD UNIT ( DECREASED HEIGHT ). A MAXIMUM OF FORTY-FOUR ( 44 ) OF THESE UNITS, FOR AN APPROXIMATE LADING WEIGHT OF 71,104 POUNDS, CAN BE PLACED IN A 40'-6" LONG CAR.
3. IF A CAR HAS BOWED END WALLS WHICH ARE BOWED OUTWARD TWO INCHES ( 2" ) OR MORE EITHER FROM SIDE-TO-SIDE OR FROM FLOOR-TO-ROOF, CROSS MEMBERS CAN BE INSTALLED NEAR THE END WALL OF THE CAR TO PROVIDE A "SQUARED END" RATHER THAN INSTALLING DUNNAGE AS SPECIFIED IN GENERAL NOTE "G" ON PAGE 2. THESE CROSS MEMBERS SHOULD BE INSTALLED AT THE SAME HEIGHTS AS THE CROSS MEMBERS USED THROUGHOUT THE LOAD AS BLOCKING MEMBERS. A SEPARATOR GATE, SHOWN AS PIECE MARKED ( ③ ), MUST BE POSITIONED AGAINST THESE CROSS MEMBERS PRIOR TO LOADING.
4. TOP-OF-LOAD ANTI-SWAY BRACES, SHOWN AS PIECES MARKED ( ③ ) IN THE LOAD ON PAGE 82, MUST BE INSTALLED IN EACH END OF THE CAR AND WIRE TIED TO THE STRAPPING BOARDS WITH NO. 14 GAGE WIRE AS TYPICALLY SHOWN BY THE "TIE WIRE APPLICATION B" DETAIL ON PAGE 122. THREE ( 3 ) BRACES ARE REQUIRED IN EACH END OF A LOAD REGARDLESS OF THE CAR LENGTH.
5. TO FACILITATE POSITIONING OF THE PALLET UNITS AS LOADING PROGRESSES, POSITION PALLET UNIT STACKS AGAINST THE END WALL, THEN POSITION A SEPARATOR GATE, SHOWN AS PIECE MARKED ( ④ ), SO THE 1" X 4" TIE PIECES ARE LOCATED UNDER THE "OVERHANG" OF THE BOTTOM AND TOP PALLET UNITS. REPEAT THIS PROCEDURE FOR THE REMAINING STACKS.
6. SEPARATOR GATES IN THE DOORWAY MUST BE PREVENTED FROM SHIFTING INTO A DOOR OPENING BY THE APPLICATION OF THE STOP PIECES, PIECES MARKED ( ⑦ ). IN CARS EQUIPPED WITH STAGGERED DOORS, STOP PIECES MAY BE REQUIRED ON UP TO FOUR SEPARATOR GATES.
7. SEPARATOR GATES MAY BE FORMED FROM 3/8" OR THICKER PLYWOOD IN LIEU OF DIMENSIONAL LUMBER, IF DESIRED, FOR ONE OR TWO-LAYER LOADS; PLYWOOD SEPARATOR GATES FOR A 3-LAYER LOAD ARE NOT ECONOMICALLY FEASIBLE. SEE THE "ALTERNATIVE SEPARATOR GATE" DETAIL ON PAGE 122 FOR CONSTRUCTION GUIDANCE.
8. IF THE CAR BEING LOADED IS EQUIPPED WITH AT LEAST TWELVE ( 12 ) DOORWAY MEMBERS, AN ADDITIONAL FOUR PALLET UNITS CAN BE LOADED IN THE DOORWAY AREA.
9. THE DEPICTED LOAD CAN BE REDUCED TO SUIT THE QUANTITY TO BE SHIPPED. A LOAD MAY BE REDUCED BY MULTIPLES OF TWO ( 2 ) PALLET UNITS BY OMITTING Laterally ADJACENT UNITS FROM THE TOP ONE OR TWO LAYERS OF ONE OR MORE LOAD UNITS, OR BY MULTIPLES OF SIX ( 6 ) PALLET UNITS BY OMITTING ONE OR MORE ENTIRE LOAD UNITS. TO REDUCE A LOAD BY ONE ( 1 ) PALLET UNIT, REFER TO THE LCL PROCEDURES ON PAGES 90 AND 91 FOR GUIDANCE.
10. FOR SHIPMENT OF ONE OR MORE LEFTOVER CONTAINERS, SEE THE "PROCEDURES FOR SHIPMENT OF LEFTOVER CONTAINERS" ON PAGE 119 FOR GUIDANCE.

**BILL OF MATERIAL**

LUMBER	LINEAR FEET	BOARD FEET
1" X 4"	250	84
1" X 6"	261	131
2" X 4"	387	258
2" X 6"	19	19
NAILS	NO. REQD	POUNDS
6d ( 2" )	336	2
10d ( 3" )	420	6-1/2
WIRE, NO. 14 GAGE ----- 60' REQD -----		1 LB

**LOAD AS SHOWN**

ITEM	QUANTITY	WEIGHT ( APPROX )
PALLET UNIT -----	56 -----	90,496 LBS
DUNNAGE -----	-----	994 LBS
TOTAL WEIGHT -----		91,490 LBS

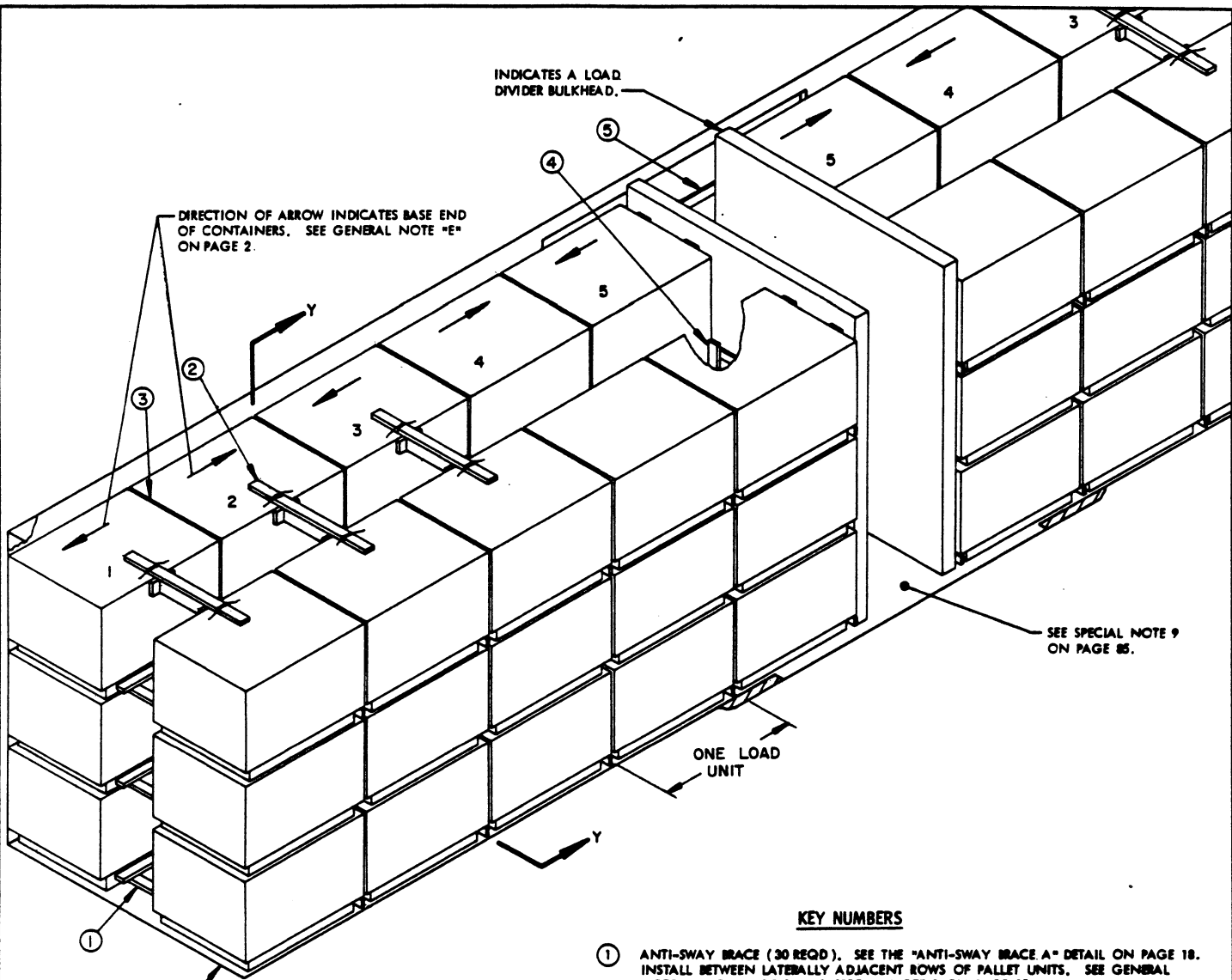

SEE GENERAL NOTES "D" AND "G" ON PAGE 2.

**ISOMETRIC VIEW**

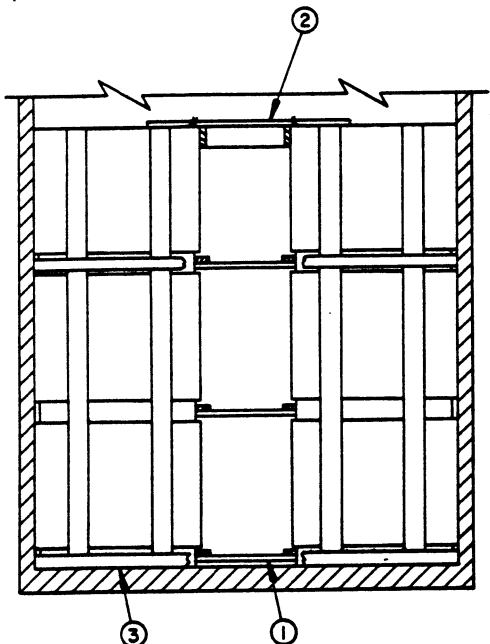

**SECTION Y-Y**

**KEY NUMBERS**

- ① ANTI-SWAY BRACE (30 REQD). SEE THE "ANTI-SWAY BRACE A" DETAIL ON PAGE 18. INSTALL BETWEEN LATERALLY ADJACENT ROWS OF PALLET UNITS. SEE GENERAL NOTE "M" ON PAGE 2 AND SPECIAL NOTE 3 ON PAGE 85.
- ② TOP-OF-LOAD ANTI-SWAY BRACE (6 REQD). SEE THE "TOP-OF-LOAD ANTI-SWAY BRACE B" DETAIL ON PAGE 46. WIRE TIE TO STRAPPING BOARDS WITH NO. 14 GAGE WIRE AS TYPICALLY SHOWN BY THE "TIE WIRE APPLICATION B" DETAIL ON PAGE 122. SEE SPECIAL NOTE 4 ON PAGE 85.
- ③ SEPARATOR GATE (10 REQD). SEE THE "SEPARATOR GATE M" DETAIL ON PAGE 87. POSITION WITH THE HORIZONTAL PIECES AGAINST THE ALREADY-LOADED UNITS. SEE SPECIAL NOTES 5 AND 7 ON PAGE 85.
- ④ STOP PIECE, 1" X 4" X 7'-0" (4 REQD). POSITION AGAINST PALLET UNITS IN THE DOORWAY AND NAIL TO THE HORIZONTAL PIECES ON PIECE MARKED ③ W/3-6d NAILS AT EACH JOINT AND CLINCH. SEE SPECIAL NOTE 6 ON PAGE 85.
- ⑤ DOORWAY PROTECTION (2 REQD). SEE THE "DOORWAY PROTECTION K" DETAIL ON PAGE 88. NAIL TO THE DOOR POSTS W/12d NAILS. SEE SPECIAL NOTE 8 ON PAGE 85.

**ROUTED DUNNAGE METHOD UNIT (DECREASED HEIGHT)  
60-UNIT LOAD IN A 50'-0" LONG BY 9'-2" WIDE BOX CAR EQUIPPED WITH LOAD DIVIDERS**

(SPECIAL NOTES CONTINUED)

- 10. THE DEPICTED LOAD CAN BE REDUCED TO SUIT THE QUANTITY TO BE SHIPPED. A 3-TIER LOAD CAN BE REDUCED BY A MULTIPLE OF SIX (6) PALLET UNITS, OR A 2-TIER LOAD CAN BE REDUCED BY A MULTIPLE OF FOUR (4) UNITS, OR A 1-TIER LOAD CAN BE REDUCED BY A MULTIPLE OF TWO (2) UNITS BY OMITTING ONE OR MORE LOAD UNITS FROM THE CENTER PORTION OF THE LOAD. OR, THE ENTIRE ONE OR TWO TOP TIERS CAN BE OMITTED. FOR OTHER METHODS OF REDUCING A LOAD, AND FOR TYPICAL LCL PROCEDURES, REFER TO PAGES 94 THRU 105 AND GENERAL NOTE "FF" ON PAGE 3 FOR GUIDANCE.
- 11. IF PALLET UNITS WHICH DO NOT CONTAIN A FULL QUANTITY OF CONTAINERS ARE TO BE TRANSPORTED, REFER TO PAGE 117 AND/OR PAGES 118 AND 120 FOR SHIPPING GUIDANCE.
- 12. FOR SHIPMENT OF ONE OR MORE LEFTOVER CONTAINERS, SEE THE "PROCEDURES FOR SHIPMENT OF LEFTOVER CONTAINERS" ON PAGE 119 FOR GUIDANCE.

SPECIAL NOTES:

- 1. A 50'-6" LONG BY 9'-2" WIDE WOOD-LINED CUSHIONED BOX CAR EQUIPPED WITH LOAD DIVIDER BULKHEADS AND WITH 10'-0" WIDE DOOR OPENINGS IS SHOWN. CARS OF OTHER DIMENSIONS AND CARS HAVING NARROWER OR WIDER DOOR OPENINGS CAN BE USED. SEE GENERAL NOTES "AA" THRU "EE" ON PAGE 3.
- 2. THE PALLET UNIT SHOWN IN THE TYPICAL LOAD ON PAGE 84 IS THE ROUTED DUNNAGE METHOD UNIT (DECREASED HEIGHT). A MAXIMUM OF SEVENTY-TWO (72) OF THESE UNITS, FOR AN APPROXIMATE LADING WEIGHT OF 116,352 POUNDS CAN BE PLACED IN A 60'-8" LONG CAR, OR A MAXIMUM OF FORTY-EIGHT (48) UNITS CAN BE LOADED IN A 40'-6" CAR FOR AN APPROXIMATE LADING WEIGHT OF 77,568 POUNDS, WHEN USING THE DEPICTED PROCEDURES. IF CARS 9'-4" OR WIDER ARE AVAILABLE, THE CROSSWISE LOADING PATTERN SHOWN ON PAGE 80 MAY BE EMPLOYED. THEN, NINETY-SIX (96) PALLET UNITS FOR AN APPROXIMATE LADING WEIGHT OF 135,136 POUNDS CAN BE PLACED IN A 60'-8" LONG CAR, SEVENTY-EIGHT (78) UNITS CAN BE LOADED IN A 50'-6" LONG CAR FOR AN APPROXIMATE LADING WEIGHT OF 126,048 POUNDS, AND SIXTY (60) UNITS CAN BE LOADED IN A 40'-6" LONG CAR FOR AN APPROXIMATE LADING WEIGHT OF 96,960 POUNDS.
- 3. IF THE "ALTERNATIVE DOORWAY PROTECTION F" PROCEDURES AS SHOWN ON PAGE 128 ARE USED IN LIEU OF THE WOODEN DOOR GATE TYPE PROTECTION, PIECE MARKED ⑤, NAILED FLOORLINE BLOCKING MUST BE USED IN LIEU OF THE LOWER ANTI-SWAY BRACE IN THE DOORWAY AREA. NAILED BLOCKING IS REQUIRED FOR ALL PALLET STACKS WHICH ARE COMPLETELY WITHIN THE DOORWAY AREA OR WHICH EXTEND INTO THE DOORWAY AREA BY ONE-HALF OR MORE OF THE STACK WIDTH ON EITHER SIDE OF THE CAR.
- 4. TOP-OF-LOAD ANTI-SWAY BRACES, SHOWN AS PIECES MARKED ② IN THE LOAD ON PAGE 84, MUST BE INSTALLED IN EACH END OF THE CAR AND WIRE TIED TO STRAPPING BOARDS WITH NO. 14 GAGE WIRE AS TYPICALLY SHOWN BY THE "TIE WIRE APPLICATION B" DETAIL ON PAGE 122. THREE (3) BRACES ARE REQUIRED IN EACH END OF A LOAD REGARDLESS OF THE CAR LENGTH.
- 5. TO FACILITATE POSITIONING OF THE PALLET UNITS AS LOADING PROGRESSES, POSITION PALLET UNIT STACKS AGAINST THE END WALL, THEN POSITION A SEPARATOR GATE SHOWN AS PIECE MARKED ③, SO THE 1" X 4" TIE PIECES ARE LOCATED UNDER THE "OVERHANG" OF THE BOTTOM AND TOP PALLET UNITS. REPEAT THIS PROCEDURE FOR THE REMAINING STACKS.
- 6. SEPARATOR GATES IN THE DOORWAY MUST BE PREVENTED FROM SHIFTING INTO A DOOR OPENING BY THE APPLICATION OF THE STOP PIECES, PIECES MARKED ④. IN CARS EQUIPPED WITH STAGGERED DOORS, STOP PIECES MAY BE REQUIRED ON UP TO FOUR SEPARATOR GATES.
- 7. SEPARATOR GATES MAY BE FORMED FROM 3/8" OR THICKER PLYWOOD IN LIEU OF DIMENSIONAL LUMBER, IF DESIRED. SEE THE "ALTERNATIVE SEPARATOR GATE" DETAIL ON PAGE 122 FOR CONSTRUCTION GUIDANCE.
- 8. DOORWAY PROTECTION IS REQUIRED FOR ALL PALLET UNIT STACKS WHICH ARE COMPLETELY WITHIN THE DOORWAY AREA OR WHICH EXTEND INTO THE DOORWAY AREA BY ONE-HALF OR MORE OF THE STACK WIDTH. THE WOODEN GATE TYPE OF DOORWAY PROTECTION, SHOWN AS PIECES MARKED ⑤ IN THE LOAD ON PAGE 84, IS APPLICABLE FOR BOX CARS EQUIPPED WITH CONVENTIONAL SLIDING DOORS AND NAILED DOOR POSTS. REFER TO PAGES 126 THRU 128 FOR ALTERNATIVE DOORWAY PROTECTION FOR CARS EQUIPPED WITH CONVENTIONAL SLIDING DOORS. IF THE CAR BEING LOADED IS EQUIPPED WITH PLUG TYPE DOORS, NAILED FLOORLINE BLOCKING AND LOAD BUNDLING STRAPS MUST BE USED. SEE THE "ALTERNATIVE DOORWAY PROTECTION F" DETAIL ON PAGE 128 FOR GUIDANCE IF THE PALLET UNITS ARE POSITIONED AS SHOWN ON PAGE 84. SEE THE "ALTERNATIVE DOORWAY PROTECTION E" DETAIL ON THAT PAGE IF THE PALLET UNITS ARE POSITIONED CROSSWISE.
- 9. A STRUT ASSEMBLY, SHOWN AS PIECE MARKED ⑥ IN THE LOAD ON PAGE 42, IS REQUIRED BETWEEN THE LOAD DIVIDER BULKHEADS WHEN THE LOAD IN EITHER END OF THE CAR IS 50,000 POUNDS OR MORE. FOR THE DEPICTED PALLET UNIT, A STRUT ASSEMBLY WILL BE REQUIRED IF THE LOAD IN ONE END OF THE CAR CONSISTS OF MORE THAN FIVE (5) LOAD UNITS, WHICH WOULD BE THE CASE IF AN OFFSET LOADING PATTERN IS EMPLOYED. THE STRUT ASSEMBLY WILL ALWAYS BE REQUIRED FOR FULL LOADS IN 60' OR LONGER CARS.

(CONTINUED AT LEFT)

BILL OF MATERIAL		
LUMBER	LINEAR FEET	BOARD FEET
1" X 4"	211	71
1" X 6"	500	250
2" X 3"	36	18
2" X 4"	424	283
NAILS	NO. REQD	POUNDS
6d (2")	336	2
10d (3")	444	7
12d (3-1/4")	36	3/4
WIRE, NO. 14 GAGE----- 60' REQD-----1 LB		

LOAD AS SHOWN

ITEM	QUANTITY	WEIGHT (APPROX)
PALLET UNITS-----	60-----	96,960 LBS
DUNNAGE-----	-----	1,255 LBS
TOTAL WEIGHT -----		98,215 LBS

ROUTED DUNNAGE METHOD UNIT (DECREASED HEIGHT)  
60-UNIT LOAD IN A 50'-6" LONG BY 9'-2" WIDE BOX CAR EQUIPPED WITH LOAD DIVIDERS

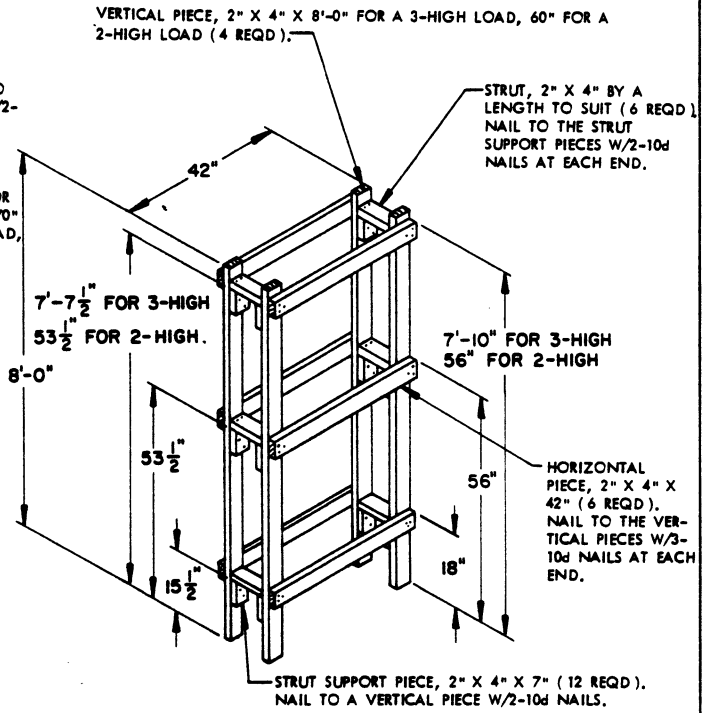
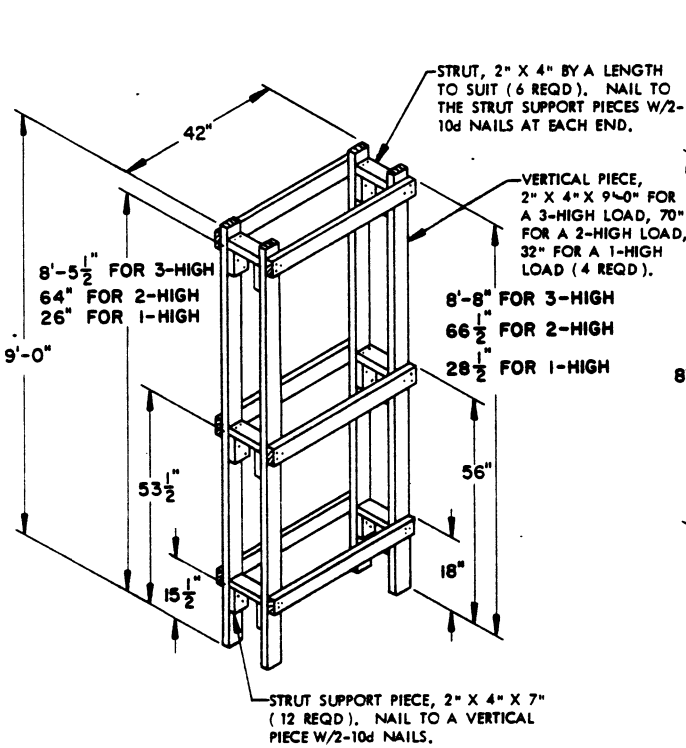

**CRIB FILL L**

CRIB FILL ASSEMBLIES "L" AND "M" SHOULD BE PRE-FABRICATED. CONSTRUCT TO BE 1/2" TO 3/4" LESS IN WIDTH THAN THE DISTANCE BETWEEN LATERALLY ADJACENT ROWS OF PALLET UNITS. OMIT THE MID-HEIGHT HORIZONTAL PIECES, STRUTS, AND STRUT SUPPORT PIECES WHEN USING CRIB FOR A 1 OR 2-HIGH LOAD.

**CRIB FILL M**

OMIT THE MID-HEIGHT HORIZONTAL PIECES, STRUTS, AND STRUT SUPPORT PIECES WHEN USING CRIB FOR A 2-HIGH LOAD. CRIB FILL "M" IS NOT REQUIRED FOR A 1-HIGH LOAD; USE CRIB FILL "L" THROUGHOUT THE LENGTH OF THE LOAD.

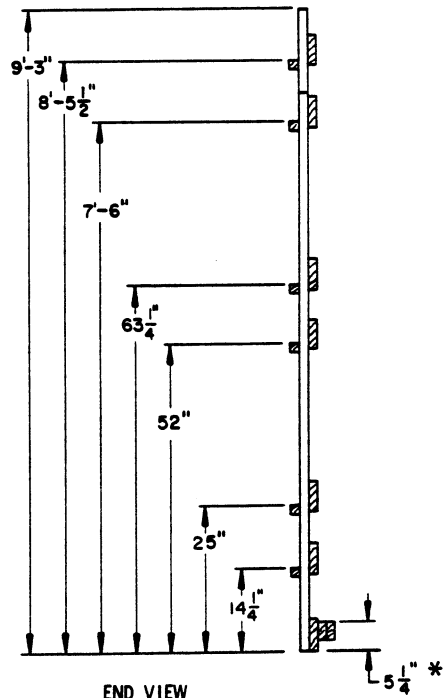
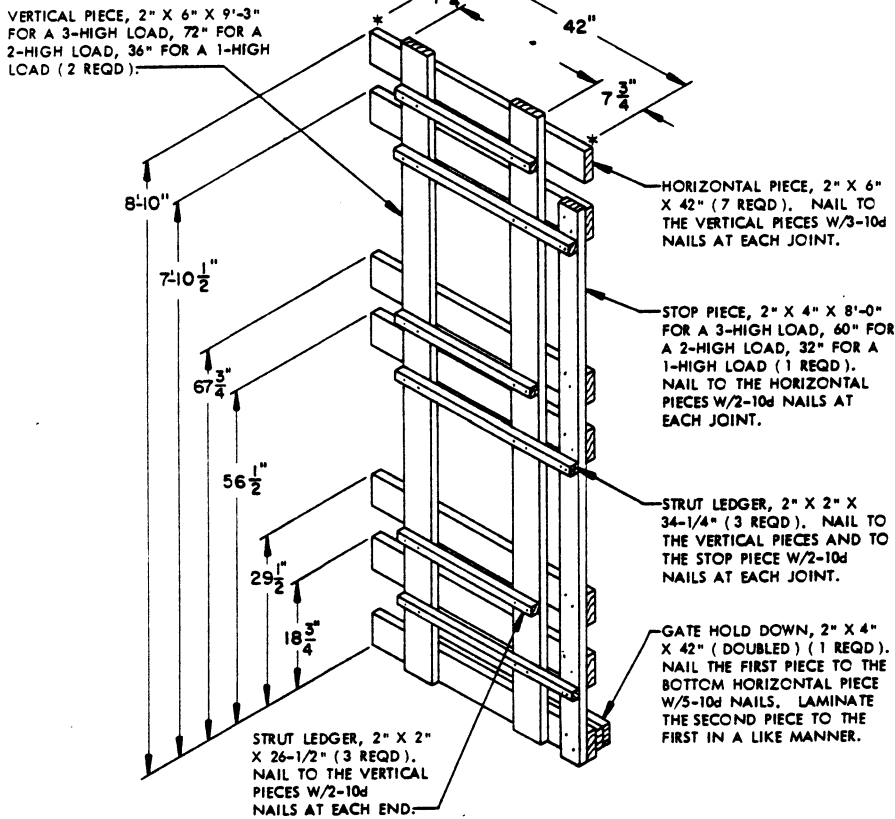

**CENTER GATE V**

1 RIGHT HAND AND 1 LEFT HAND GATE REQUIRED. NOTE THAT THE SECOND STRUT LEDGER FROM THE BOTTOM MUST BE 34-1/4" LONG FOR A 1-HIGH LOAD.

\* THE DIMENSION SHOWN IS FOR A GATE WHICH IS TO BE POSITIONED AGAINST THE BELL ENDS OF THE CONTAINERS. THIS DIMENSION WILL BE 5-3/4" FOR THE BASE END OF THE UNITS.

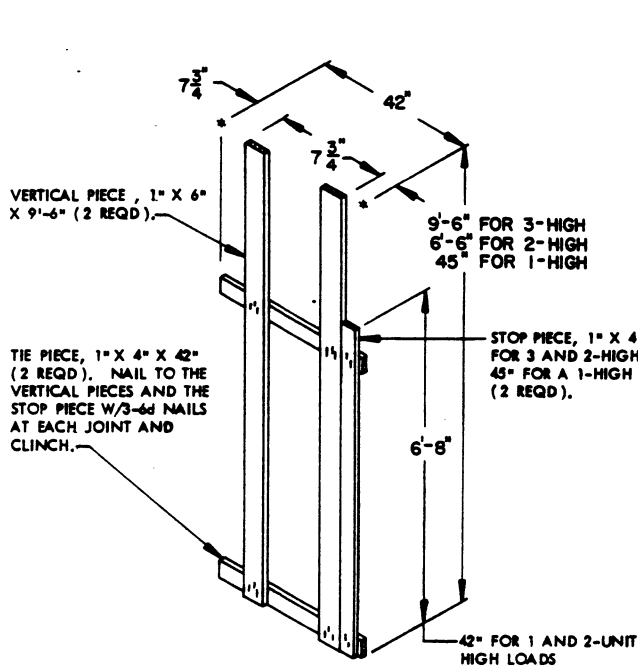

**SEPARATOR GATE L**

RIGHT HAND AND LEFT HAND GATES ARE REQUIRED. A RIGHT HAND GATE IS SHOWN.

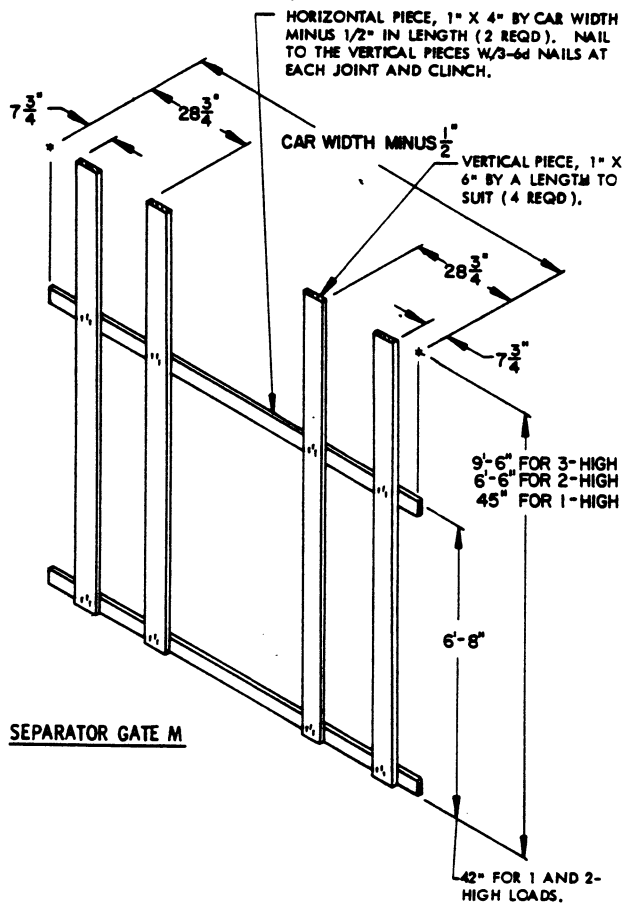

**SEPARATOR GATE M**

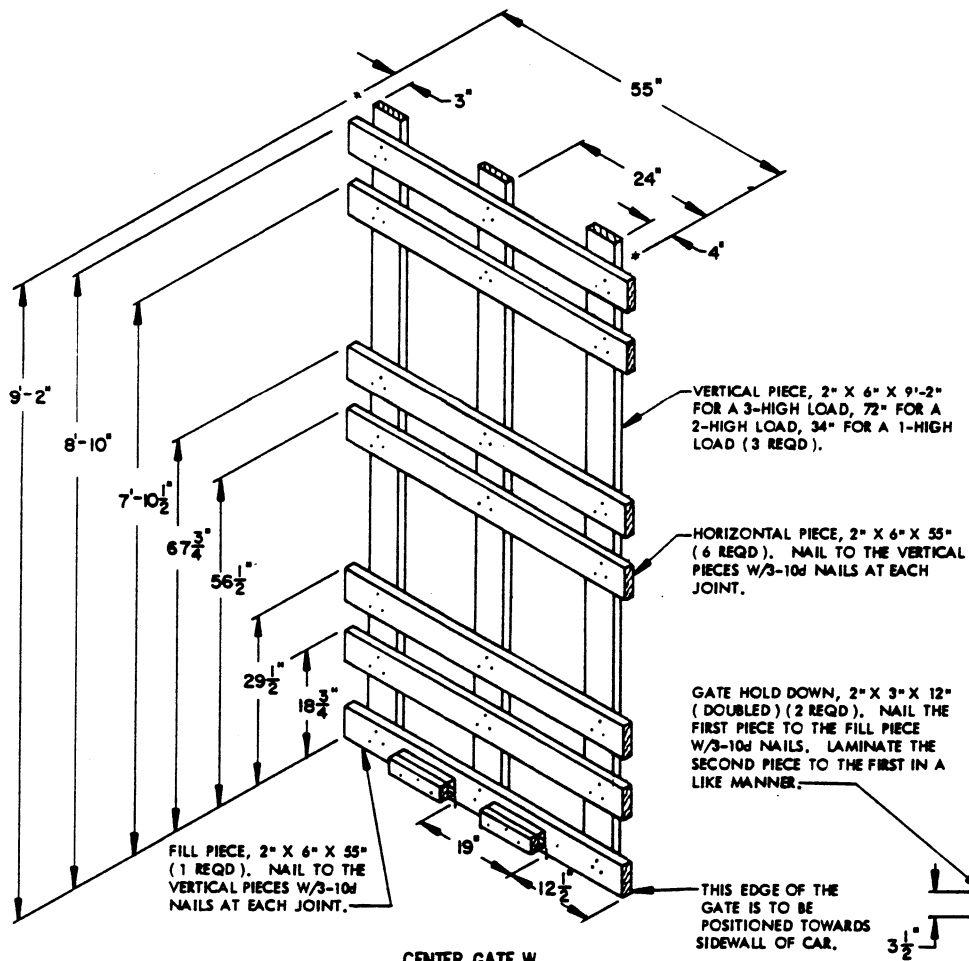

**CENTER GATE W**

1 RIGHT HAND AND 1 LEFT HAND GATE REQUIRED.

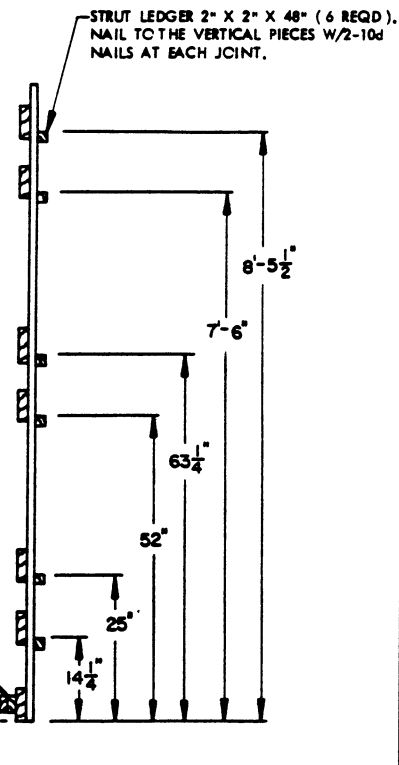

**END VIEW**

NOTE THAT THE UPPER STRUT LEDGER FOR EACH TIER ON ONE GATE MAY NEED TO BE APPLIED AFTER THE NEXT LOWER LEVEL STRUTS HAVE BEEN INSTALLED.

HORIZONTAL PIECE, 1" X 6" BY DOOR OPENING WIDTH (6 REQD). NAIL TO THE VERTICAL PIECES W/3-6d NAILS AT EACH END.

DOOR OPENING WIDTH

VERTICAL PIECE, 2" X 3" X 8'-10" (2 REQD). NAIL TO A DOOR POST W/12d NAILS.

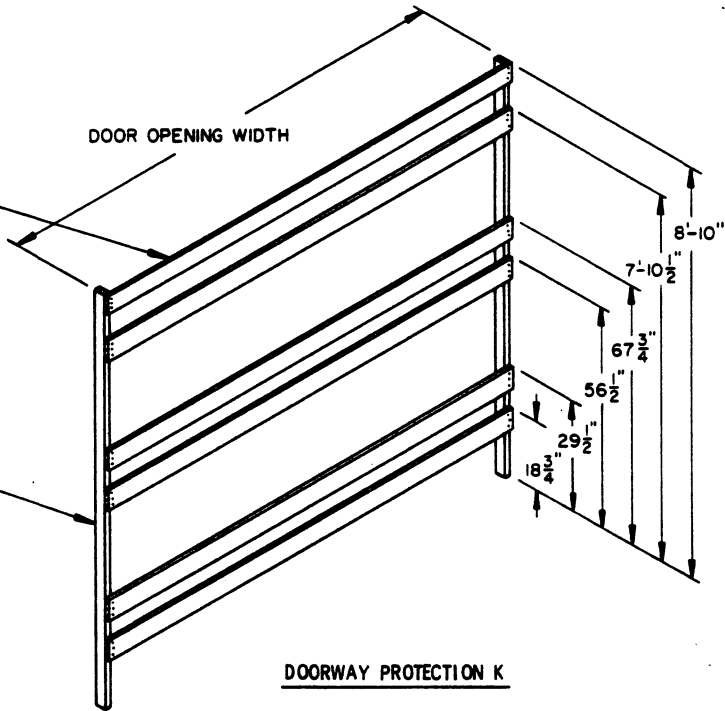

**DOORWAY PROTECTION K**

HORIZONTAL PIECE, 2" X 6" BY CAR WIDTH MINUS 1/2" IN LENGTH (6 REQD). NAIL TO THE VERTICAL PIECES W/3-10d NAILS AT EACH JOINT.

VERTICAL PIECE, 2" X 6" X 9'-0" FOR A 3-HIGH LOAD, 72" FOR A 2-HIGH LOAD, 36" FOR A 1-HIGH LOAD (4 REQD).

FILL PIECE, 2" X 6" X 41-1/4" (2 REQD). NAIL TO THE VERTICAL PIECES W/3-10d NAILS AT EACH JOINT.

GATE HOLD DOWN, 2" X 4" X 18" (DOUBLED) (2 REQD). NAIL THE FIRST PIECE TO THE FILL PIECE W/5-10d NAILS. LAMINATE THE SECOND PIECE TO THE FIRST IN A LIKE MANNER. SEE SPECIAL NOTE 11 ON PAGE 79.

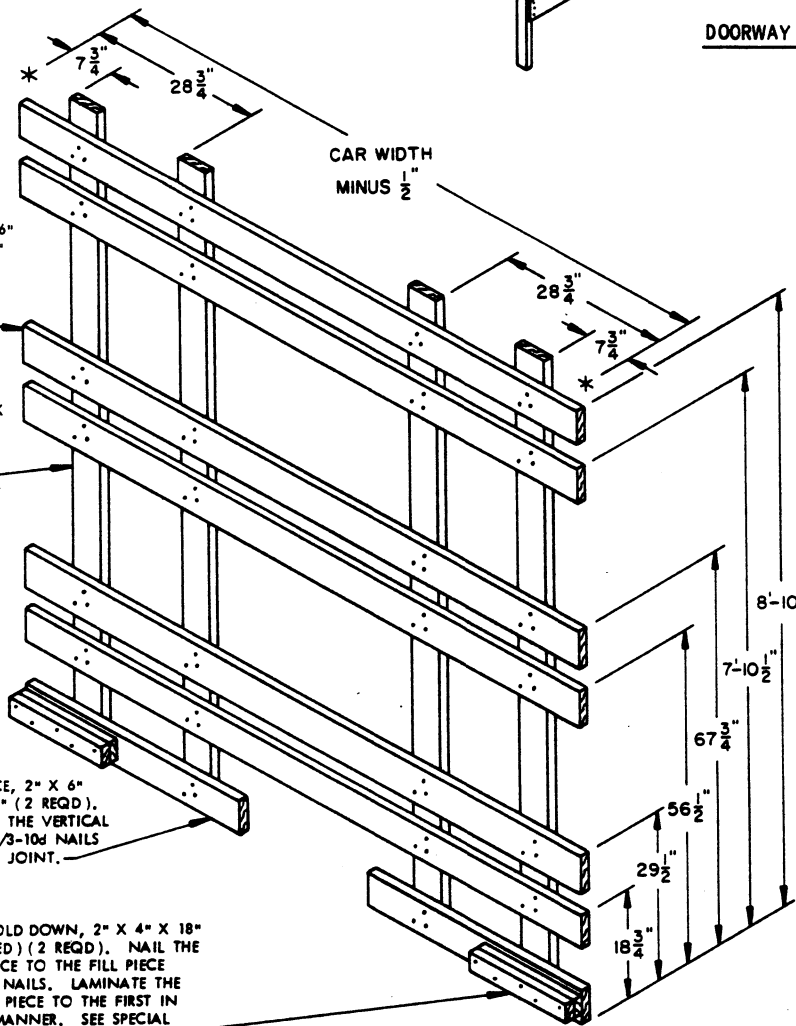

**CENTER GATE X**

STRUT LEDGER, 2" X 2" BY CAR WIDTH MINUS 16" IN LENGTH (6 REQD). NAIL TO THE VERTICAL PIECES W/2-10d NAILS AT EACH JOINT.

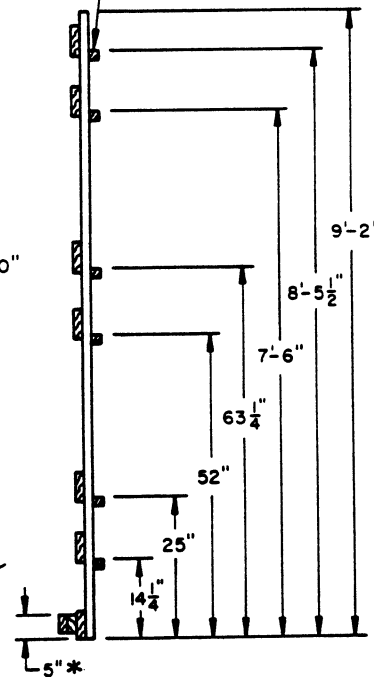

**END VIEW**

\*THE DIMENSION SHOWN IS FOR A GATE WHICH IS TO BE POSITIONED AGAINST THE BELL END OF CONTAINERS. THIS DIMENSION WILL BE 5-3/4" FOR THE BASE END OF UNITS.



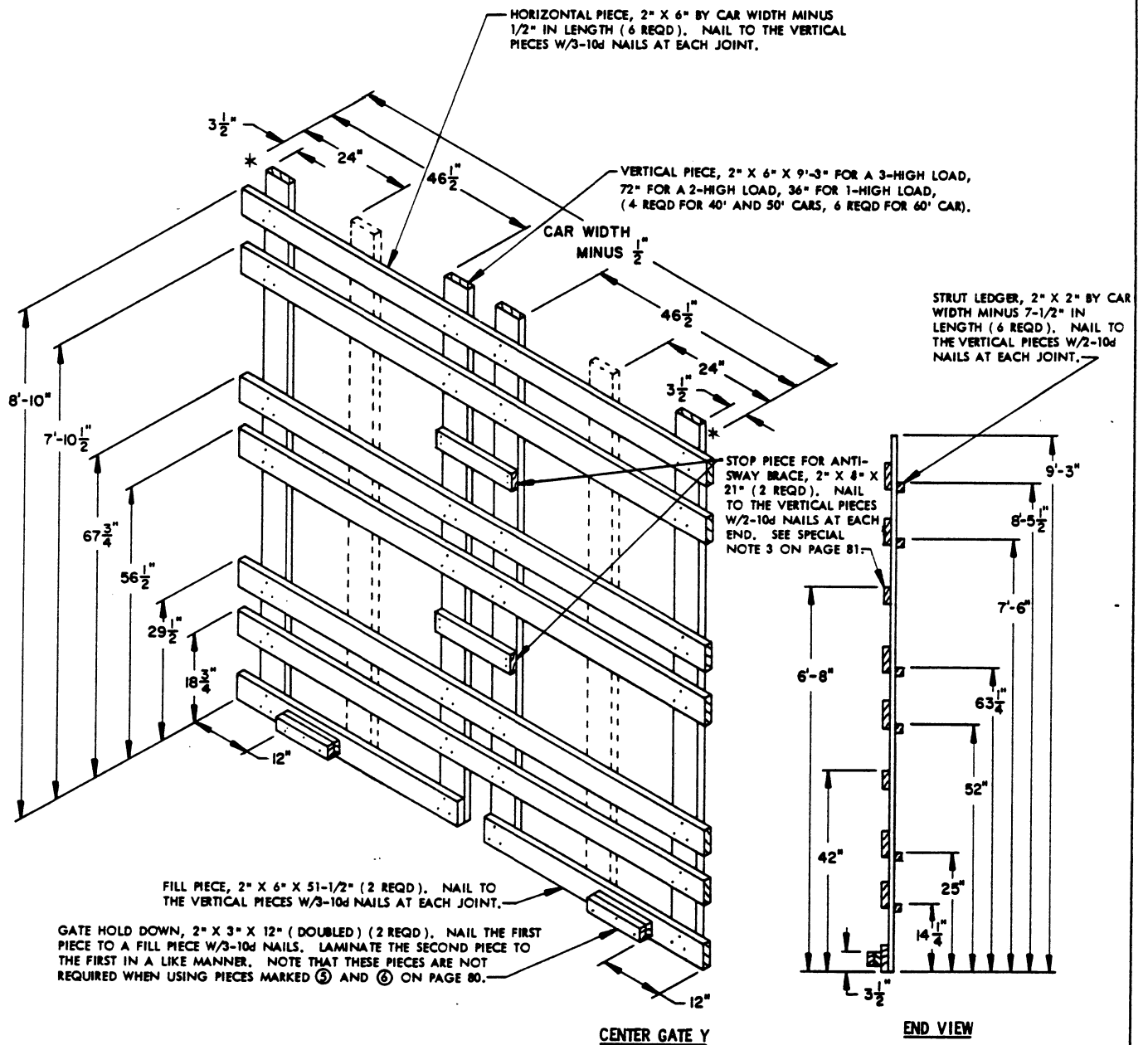

**DETAILS FOR ROUTED DUNNAGE METHOD UNIT (DECREASED HEIGHT)**

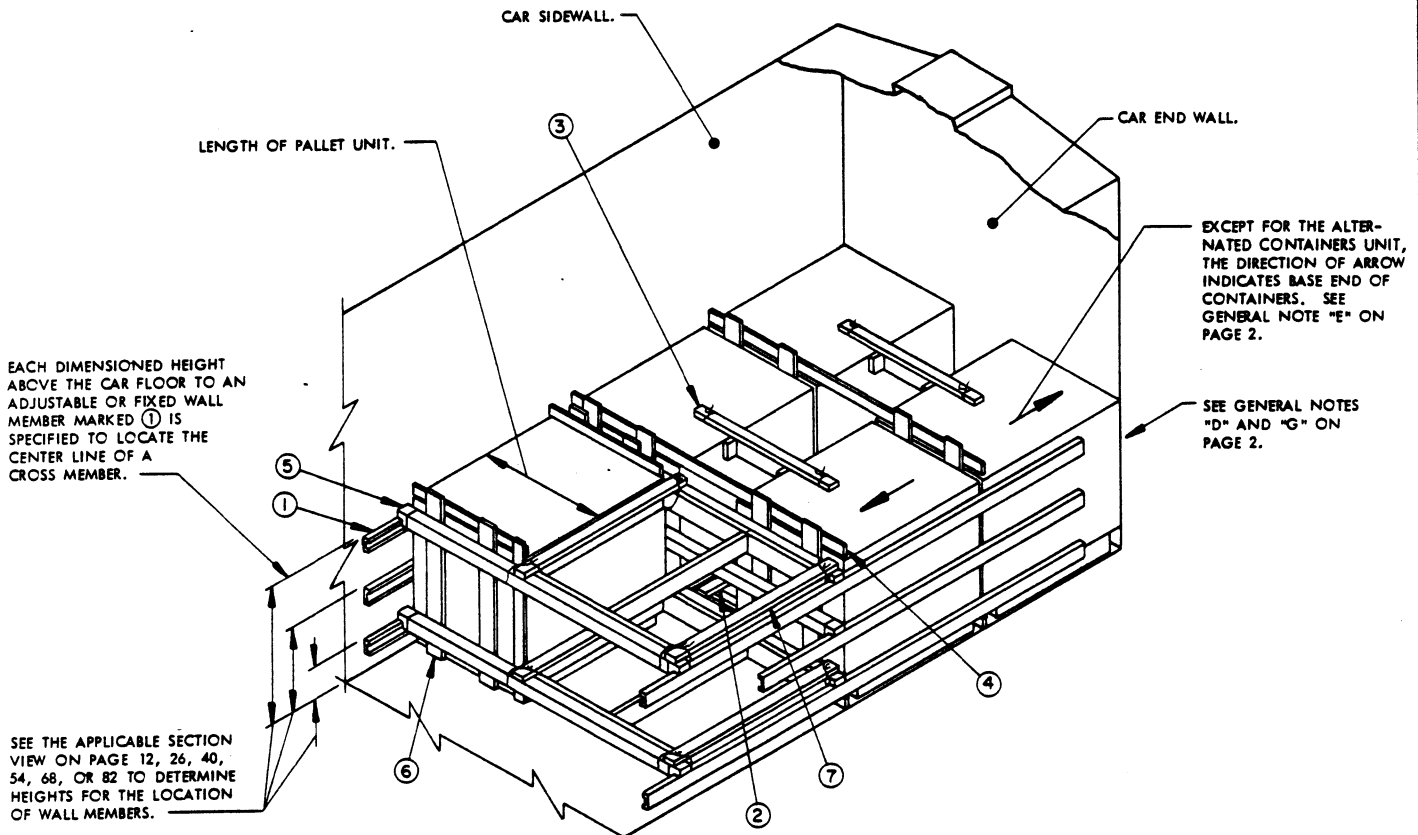

**ISOMETRIC VIEW**

**KEY NUMBERS**

**SPECIAL NOTES:**

1. A 9'-0" WIDE (INSIDE CLEARANCE) WOOD-LINED BOX CAR EQUIPPED WITH ADJUSTABLE AND/OR FIXED WALL MEMBERS IS SHOWN. CARS OF OTHER WIDTHS CAN BE USED. SEE GENERAL NOTE "D" ON PAGE 2.
2. THE PALLET UNIT SHOWN IN THE TYPICAL LCL LOAD IS THE ROUTED DUNNAGE METHOD UNIT (BASIC HEIGHT). THE DEPICTED PROCEDURES ARE ALSO APPLICABLE FOR THE OTHER UNITS COVERED BY THIS DOCUMENT.
3. FIVE (5) UNITS ARE SHOWN AS A TYPICAL LOAD QUANTITY. THE NUMBER OF UNITS CAN BE ADJUSTED TO SUIT THE QUANTITY TO BE SHIPPED.
4. TOP-OF-LOAD ANTI-SWAY BRACES, SHOWN AS PIECES MARKED ③, MUST BE INSTALLED IN EACH END OF THE CAR AND WIRE TIED TO A UNIT WITH NO. 14 GAGE WIRE. THREE (3) BRACES ARE REQUIRED IN EACH END OF A LOAD REGARDLESS OF THE CAR LENGTH.
5. SEPARATOR GATES MAY BE FORMED FROM 3/8" OR THICKER PLYWOOD IN LIEU OF DIMENSIONAL LUMBER, IF DESIRED. CONSTRUCT EACH GATE TO BE CAR WIDTH MINUS 1/2" IN LENGTH BY UNIT HEIGHT, OR UNIT LENGTH IN WIDTH BY UNIT HEIGHT, AS APPLICABLE.
6. THE SPACER ASSEMBLIES, SHOWN AS PIECES MARKED ⑦, MAY ALSO BE USED IN AN UPPER LAYER OF A LOAD FOR THE OMISSION OF A PALLET UNIT. IF THE ASSEMBLIES ARE USED NEXT TO THE CAR END WALL IN EITHER A FIRST LAYER OR IN AN UPPER LAYER, AND THE END WALL IS WOOD-LINED, CUT THE ADJACENT ENDS OFF THE SUPPORT PIECES FLUSH WITH THE LATERAL PIECE. EACH ASSEMBLY CAN THEN BE SUPPORTED BY NAILING THE LATERAL PIECE TO THE CAR END WALL W/6-10d NAILS. IF THE END WALL IS NON-NAILABLE, CROSS MEMBERS MUST BE INSTALLED AT THE END OF THE LOAD TO SUPPORT THE SPACER ASSEMBLIES.

- ① WALL MEMBER, ADJUSTABLE OR FIXED. MEMBERS MUST BE LOCATED AT THE SPECIFIED HEIGHTS ABOVE THE CAR FLOOR TO PROVIDE PROPER ALIGNMENT OF CROSS MEMBERS MARKED ⑤.
- ② ANTI-SWAY BRACE (2 REQD). SEE THE "ANTI-SWAY BRACE A" DETAIL ON PAGE 18. INSTALL BETWEEN LATERALLY ADJACENT ROWS OF PALLET UNITS. SEE GENERAL NOTE "M" ON PAGE 2.
- ③ TOP-OF-LOAD ANTI-SWAY BRACE (2 REQD). SEE THE "TOP-OF-LOAD ANTI-SWAY BRACE A" DETAIL ON PAGE 19 FOR THE ALTERNATED CONTAINERS UNIT OR THE "TOP-OF-LOAD ANTI-SWAY BRACE B" DETAIL ON PAGE 46 FOR THE FLAT OR ROUTED DUNNAGE METHOD UNITS. WIRE TIE TO PALLET UNITS AS SHOWN BY THE APPLICABLE TIE WIRE APPLICATION DETAIL ON PAGE 122.
- ④ SEPARATOR GATE FOR 1-HIGH AND 2-WIDE (2 REQD). SEE THE APPLICABLE SEPARATOR GATE DETAIL FOR TWO UNITS WIDE ON PAGE 17, 31, 45, 59, 73, OR 87. POSITION WITH THE 1" X 4" HORIZONTAL PIECES AGAINST THE ALREADY-LOADED UNITS.
- ⑤ CROSS MEMBER (5 REQD). SEE GENERAL NOTE "W" ON PAGE 3.
- ⑥ SEPARATOR GATE FOR 1-HIGH AND 1-WIDE (2 REQD, 1 RIGHT HAND AND 1 LEFT HAND). SEE THE APPLICABLE SEPARATOR GATE DETAIL FOR ONE UNIT WIDE ON PAGE 17, 31, 45, 59, 73, OR 87. AS APPLICABLE, POSITION WITH THE 1" X 4" HORIZONTAL PIECES AGAINST THE ALREADY-LOADED UNITS.
- ⑦ SPACER ASSEMBLY (2 REQD). SEE THE DETAIL ON PAGE 91 AND SPECIAL NOTE 6 AT LEFT. WIRE TIE TO CROSS MEMBER W/2 WRAPS OF NO. 14 GAGE WIRE AT EACH CORNER.

**TYPICAL LCL (5-UNIT LOAD) IN A BOX CAR EQUIPPED WITH MECHANICAL BRACING DEVICES HAVING ADJUSTABLE OR FIXED WALL MEMBERS**

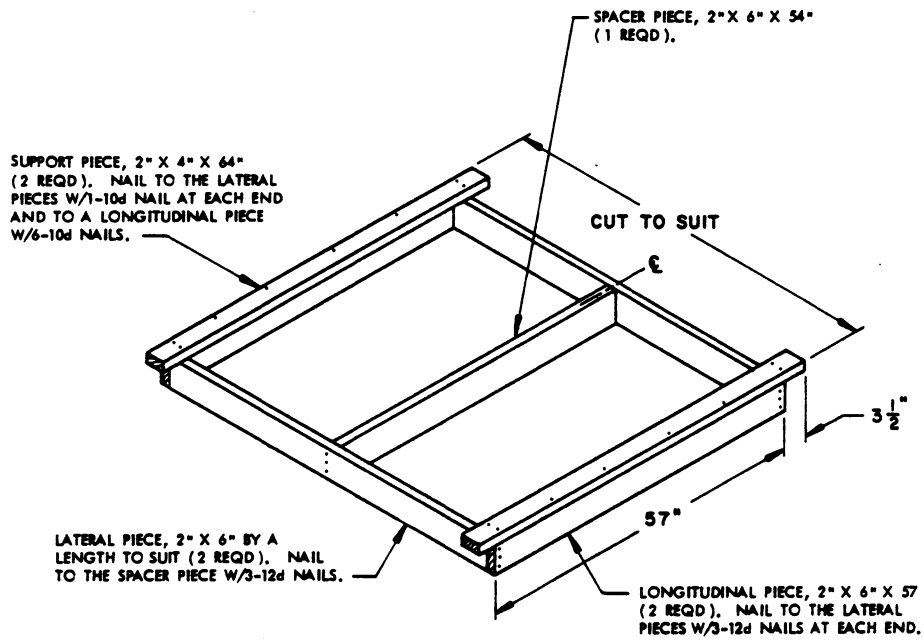

**SPACER ASSEMBLY**

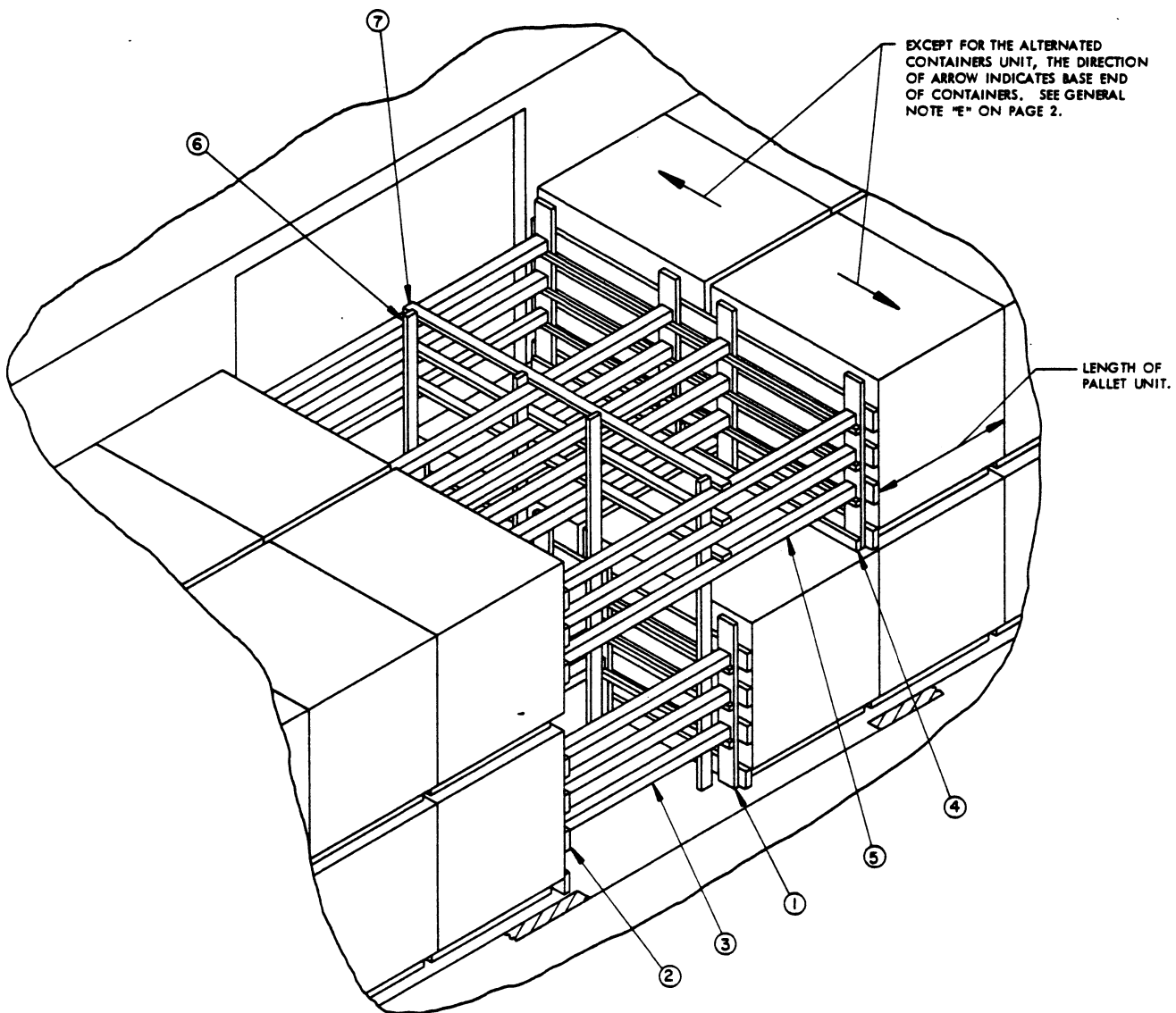

ISOMETRIC VIEW

KEY NUMBERS

SPECIAL NOTES:

1. ONLY THE CENTER PORTION OF A 9'-4" WIDE CONVENTIONAL TYPE BOX CAR IS SHOWN TO PORTRAY THE STRUTTED GATE METHOD OF PARTIAL-LAYER BRACING. WIDER CARS CAN ALSO BE USED.
2. THE PALLET UNIT SHOWN IS THE ROUTED DUNNAGE METHOD UNIT (BASIC HEIGHT). THE DEPICTED PROCEDURES ARE ALSO ADAPTABLE FOR THE OTHER UNITS COVERED BY THIS DOCUMENT.
3. THE PROCEDURES FOR THE ADJUSTMENT OF A LOAD QUANTITY BY THE OMISSION OF THE TOP LAYER FROM A 2-HIGH LOAD ARE SHOWN AS TYPICAL. THE PRINCIPLES MAY ALSO BE APPLIED FOR THE OMISSION OF THE TOP ONE OR TWO LAYERS FROM A 3-HIGH LOAD.
4. ONLY THE BLOCKING AND BRACING PIECES WHICH ARE NECESSARY TO PERMIT THE OMISSION OF THE UNITS FROM THE TOP LAYER ARE SHOWN.
5. THE CENTER GATE "U" USED IS ONLY APPLICABLE FOR THE ROUTED DUNNAGE METHOD UNIT DEPICTED. THE PROPER CENTER GATE TO BE USED WILL DEPEND UPON THE UNIT BEING SHIPPED. THE QUANTITY REQUIRED FOR DUNNAGE PIECES, SUCH AS THE NUMBER OF STRUTS OR THE NUMBER OF STRUT BRACING PIECES, WILL ALSO VARY DEPENDENT UPON THE UNIT BEING LOADED.

- ① CENTER GATE FOR 1-HIGH (2 REQD). SEE THE "CENTER GATE U" DETAIL ON PAGE 75. SEE GENERAL NOTE "M" ON PAGE 2 AND SPECIAL NOTE 5 AT THE LEFT.
- ② CENTER GATE FOR 2-HIGH (1 REQD). SEE THE "CENTER GATE U" DETAIL ON PAGE 75.
- ③ STRUT, 4" X 4" BY CUT TO FIT (AS REQD). POSITION BETWEEN THE CENTER GATES, PIECES MARKED ① AND ②, IN THE FIRST LAYER AND TOENAIL W/2-16d NAILS AT EACH END. SEE GENERAL NOTES "L", "S", AND "T" ON PAGE 2.
- ④ GATE SUPPORT PIECE, 2" X 4" BY A LENGTH TO SUIT (1 REQD). NAIL TO THE VERTICAL PIECES OF THE CENTER GATE USED IN THE SECOND LAYER W/3-10d NAILS AT EACH JOINT.
- ⑤ STRUT, 4" X 4" BY CUT TO FIT (AS REQD). POSITION BETWEEN THE CENTER GATES, PIECES MARKED ① AND ②, IN THE SECOND LAYER AND TOENAIL W/2-16d NAILS AT EACH END.
- ⑥ VERTICAL STRUT BRACING, 2" X 4" BY CUT TO EXTEND 3" ABOVE THE TOP STRUT (AS REQD). NAIL TO THE STRUTS W/3-10d NAILS AT EACH JOINT.
- ⑦ HORIZONTAL STRUT BRACING, 2" X 4" BY CAR WIDTH MINUS 1/2" IN LENGTH (AS REQD). NAIL TO THE STRUTS W/3-10d NAILS AT EACH JOINT.

**CROSSWISE-POSITIONED PALLET UNITS  
TYPICAL LCL LOAD USING STRUTTED GATE METHOD OF PARTIAL-LAYER BRACING**

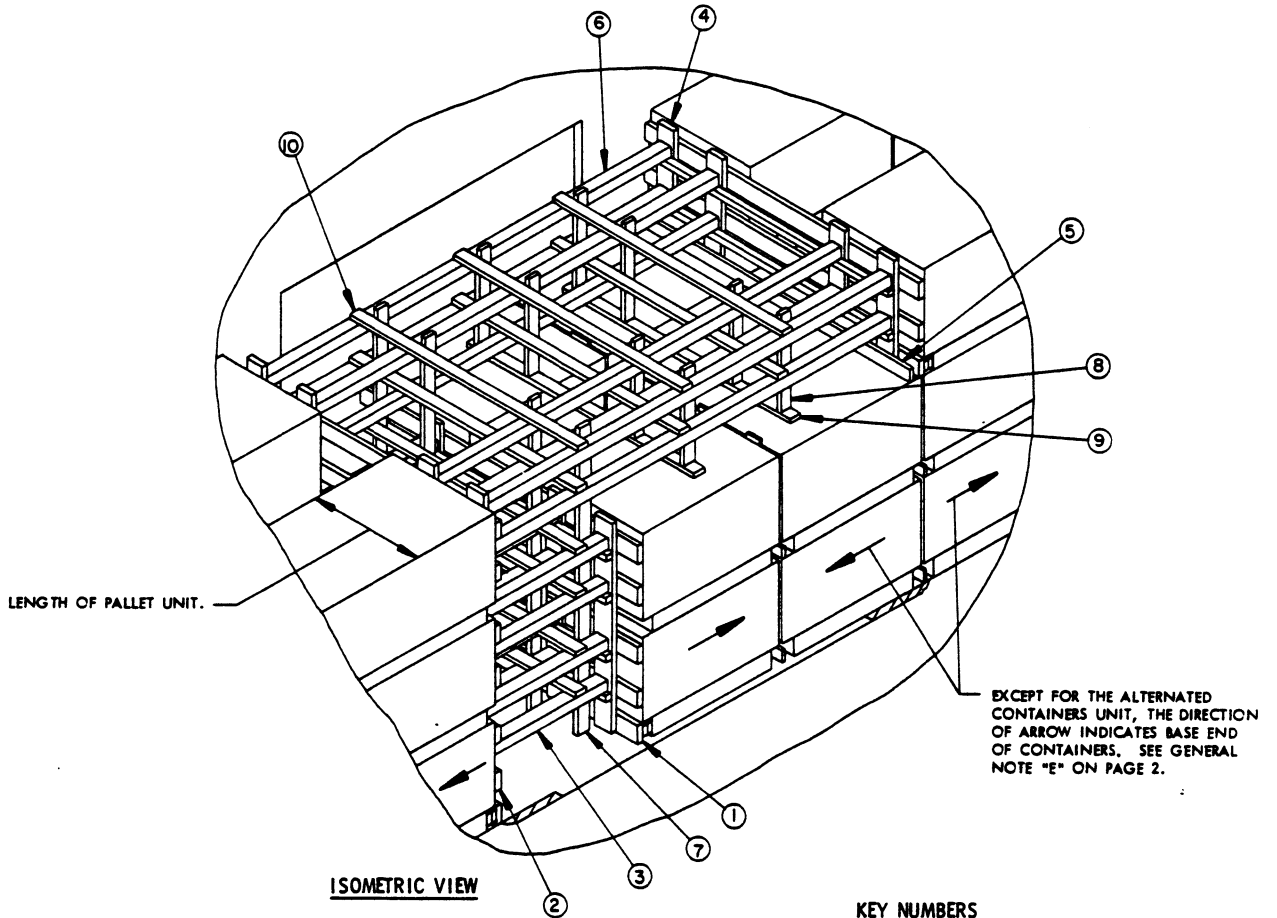

**SPECIAL NOTES:**

1. ONLY THE CENTER PORTION OF A 9'-2" WIDE CONVENTIONAL TYPE BOX CAR IS SHOWN TO PORTRAY THE STRUTTED GATE METHOD OF PARTIAL-LAYER BRACING. CARS OF OTHER WIDTHS CAN ALSO BE USED.
2. THE PALLET UNIT SHOWN IS THE ALTERNATED CONTAINERS UNIT (BASIC HEIGHT). THE DEPICTED PROCEDURES ARE ALSO ADAPTABLE FOR THE OTHER UNITS COVERED BY THIS DOCUMENT.
3. THE PROCEDURES FOR THE ADJUSTMENT OF A LOAD QUANTITY BY THE OMISSION OF THE TOP LAYER FROM TWO (2) LOAD UNITS ARE SHOWN AS TYPICAL. THE PRINCIPLES MAY ALSO BE APPLIED FOR THE OMISSION OF THE TOP LAYER FROM JUST ONE (1) LOAD UNIT.
4. ONLY THE BLOCKING AND BRACING PIECES WHICH ARE NECESSARY TO PERMIT THE OMISSION OF THE UNITS FROM THE TOP LAYER ARE SHOWN.
5. THE CENTER GATE "C" USED IS ONLY APPLICABLE FOR THE ALTERNATED CONTAINERS UNIT DEPICTED. THE PROPER CENTER GATE TO BE USED WILL DEPEND UPON THE UNIT BEING SHIPPED. THE QUANTITY REQUIRED FOR DUNNAGE PIECES, SUCH AS THE NUMBER OF STRUTS OR THE NUMBER OF STRUT BRACING PIECES, WILL ALSO VARY DEPENDENT UPON THE UNIT BEING LOADED.
6. TO PROTECT THE LADING FROM BEING PUNCTURED WHEN A SET OF VERTICAL STRUT BRACING IS INSTALLED ABOVE THE LOWER LAYER OF A LOAD, A SUITABLE LENGTH PAD OF 2" X 4" MATERIAL, SHOWN AS PIECE MARKED ⑨, MUST BE POSITIONED UNDER AND SECURED TO EACH APPLICABLE VERTICAL STRUT BRACING PIECE.

**KEY NUMBERS**

- ① CENTER GATE FOR 2-HIGH (1 REQD). SEE THE "CENTER GATE C" DETAIL ON PAGE 18. SEE SPECIAL NOTE 5 AT LEFT.
- ② CENTER GATE FOR 3-HIGH (1 REQD). SEE THE "CENTER GATE C" DETAIL ON PAGE 18.
- ③ STRUT, 4" X 4" BY CUT TO FIT (16 REQD). TOENAIL TO PIECES MARKED ① AND ② W/2-16d NAILS AT EACH END. SEE GENERAL NOTES "L", "S", AND "T" ON PAGE 2.
- ④ CENTER GATE FOR 1-HIGH (1 REQD). SEE THE "CENTER GATE C" DETAIL ON PAGE 18.
- ⑤ SUPPORT PIECE, 2" X 4" BY CAR WIDTH MINUS 1/2" IN LENGTH (1 REQD). NAIL TO THE VERTICAL PIECES ON CENTER GATE "C", SHOWN AS PIECE MARKED ④.
- ⑥ STRUT, 4" X 4" BY CUT TO FIT (8 REQD). TOENAIL TO PIECES MARKED ② AND ④ W/2-16d NAILS AT EACH END.
- ⑦ VERTICAL STRUT BRACING, 2" X 4" BY CUT TO EXTEND 3" ABOVE THE TOP STRUT (4 REQD). NAIL TO THE STRUTS MARKED ③ AND ⑥ W/3-10d NAILS AT EACH JOINT.
- ⑧ VERTICAL STRUT BRACING, 2" X 4" BY CUT TO EXTEND 3" ABOVE THE TOP STRUT (8 REQD). NAIL TO THE STRUTS MARKED ⑥ W/3-10d NAILS AT EACH JOINT. TOENAIL TO THE STRUT BRACING PAD, PIECE MARKED ⑨, W/1-10d NAIL AT EACH JOINT. SEE SPECIAL NOTE 6 AT LEFT.
- ⑨ STRUT BRACING PAD, 2" X 4" BY LENGTH TO SUIT (2 REQD). POSITION UNDER THE VERTICAL STRUT BRACING AS SHOWN.
- ⑩ HORIZONTAL STRUT BRACING, 2" X 4" BY A LENGTH TO SUIT (10 REQD). NAIL TO THE STRUTS W/3-10d NAILS AT EACH JOINT.

SEPARATOR GATE (1 OR 2 REQD, AS APPLICABLE). SEE THE "SEPARATOR GATE N" DETAIL ON PAGE 95. POSITION AS SHOWN WITH THE VERTICAL PIECES AGAINST THE CROSSWISE POSITIONED PALLET UNITS.

STOP PIECES, 2" X 4" BY A LENGTH TO SUIT (2 REQD). POSITION SO AS TO BE IN CONTACT WITH THE ADJACENT CONTAINERS AND SECURE BY NAILING THRU THE HORIZONTAL PIECES OF THE SEPARATOR GATE W/3-6d NAILS AT EACH JOINT. NOTE THAT STOP PIECES ARE ONLY REQUIRED ON SEPARATOR GATES WHICH ARE IN THE DOOR OPENING OR WITH IN SIX INCHES (6") OF BEING IN THE DOOR OPENING.

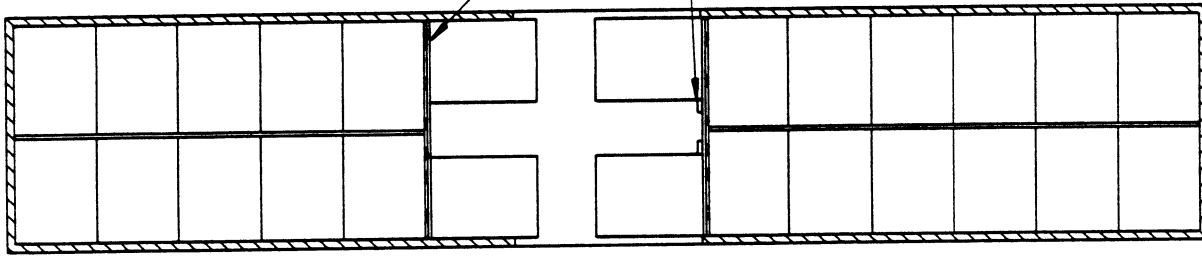

TYPICAL COMBINATION LOAD PATTERN PLAN VIEW

A 10 LONG PLUS 2 WIDE LOAD IS SHOWN.

SPECIAL NOTES:

1. A 50'-6" LONG BY 9'-4" WIDE CONVENTIONAL TYPE BOX CAR IS SHOWN. WIDER CARS AND CARS OF OTHER LENGTHS CAN BE USED.
2. THE PROCEDURES ON THIS PAGE AND ON PAGE 95 ARE PRESENTED TO PROVIDE A METHOD OF OBTAINING A LOAD QUANTITY WHICH MAY NOT BE READILY ATTAINABLE BY ANY OF THE OTHER METHODS OF ADJUSTING A LOAD QUANTITY SPECIFIED HEREIN, INCLUDING THE DEPICTED LCL PROCEDURES.
3. THE BLOCKING AND BRACING FOR THE COMBINATION LOAD, OTHER THAN SEPARATOR GATE "N", HAS NOT BEEN SHOWN. REFER TO THE APPLICABLE LOAD PAGES FOR BLOCKING AND BRACING SPECIFICATIONS. A SEPARATOR GATE "N" MUST BE INSTALLED AT EVERY LOCATION WHERE THE DIRECTION OF THE UNITS CHANGES. THE GATE MUST BE POSITIONED SO THAT THE VERTICAL PIECES ARE AGAINST THE CROSSWISE UNITS OF THE LOAD.
4. A CHART FOR EACH OF THE THREE TYPES OF PALLET UNITS IS SHOWN ON THIS PAGE. THE VARIOUS QUANTITIES (PER LAYER) WHICH CAN BE ATTAINED BY THE COMBINATION LOAD METHOD, AND THE PATTERNS REQUIRED TO PROVIDE THESE QUANTITIES, ARE SPECIFIED. FOR COMPARISON PURPOSES, THE OTHER TYPE LOADS WHICH CAN BE USED TO ATTAIN A LIKE QUANTITY, OR A QUANTITY WITHIN THE RANGE OF THE COMBINATION LOAD METHOD, AS WELL AS THE APPROXIMATE LENGTH OF THE STRUTS, ARE ALSO INCLUDED IN THE CHARTS.

FLAT DUNNAGE METHOD UNIT

CAR LENGTH	UNITS PER LAYER	LOAD PATTERN	APPROX STRUT LENGTH
40'-6" CAR	20	CROSSWISE LOAD ON PAGE 38 OR 52	50"
	20	9 LONG AT 43" PLUS 1 WIDE AT 55-3/8"	36"
	18"	5 LONG AT 43" PLUS 4 WIDE AT 55-3/8"	40"
	18"	4 LONG AT 43" PLUS 5 WIDE AT 55-3/8"	28"
	16	LENGTHWISE LOAD ON PAGE 36 OR 50.	37"
50'-6" CAR	26	CROSSWISE LOAD ON PAGE 38 OR 52	41"
	26	12 LONG AT 43" PLUS 1 WIDE AT 55-3/8"	27"
	24	9 LONG AT 43" PLUS 3 WIDE AT 55-3/8"	43"
	24	8 LONG AT 43" PLUS 4 WIDE AT 55-3/8"	31"
	23	COMBINATION LOAD ON PAGE 34 OR 48	46" & 41"
	22	4 LONG AT 43" PLUS 7 WIDE AT 55-3/8"	37"
	22	3 LONG AT 43" PLUS 8 WIDE AT 55-3/8"	25"
20	LENGTHWISE LOAD ON PAGE 36 OR 50	43"	
60'-8" CAR	32	CROSSWISE LOAD ON PAGE 38 OR 52	34"
	30	12 LONG AT 43" PLUS 3 WIDE AT 55-3/8"	36"
	30	11 LONG AT 43" PLUS 4 WIDE AT 55-3/8"	24"
	28"	7 LONG AT 43" PLUS 7 WIDE AT 55-3/8"	30"
	26	3 LONG AT 43" PLUS 10 WIDE AT 55-3/8"	36"
	24	LENGTHWISE LOAD ON PAGE 36 OR 50	57"

\*THE COMBINATION LOAD ON PAGE 34 OR 48 MAY BE USED, IF DESIRED. STRUTS FOR THE COMBINATION LOAD WILL BE APPROXIMATELY 37" AND 50", AND 57" AND 34" IN 40' AND 60' CARS, RESPECTIVELY.

ALTERNATED CONTAINERS UNIT

CAR LENGTH	UNITS PER LAYER	LOAD PATTERN	APPROX STRUT LENGTH
40'-6" CAR	22	CROSSWISE LOAD ON PAGE 10 OR 24	31"
	20	8 LONG AT 40-3/4" PLUS 2 WIDE AT 55-3/8"	40"
	20	7 LONG AT 40-3/4" PLUS 3 WIDE AT 55-3/8"	25"
	19	COMBINATION LOAD ON PAGE 6 OR 20	37" & 31"
	18	5 LONG AT 40-3/4" PLUS 4 WIDE AT 55-3/8"	51"
	18	4 LONG AT 40-3/4" PLUS 5 WIDE AT 55-3/8"	37"
	16	LENGTHWISE LOAD ON PAGE 8 OR 22	37"
50'-6" CAR	28	CROSSWISE LOAD ON PAGE 10 OR 24	29"
	26	11 LONG AT 40-3/4" PLUS 2 WIDE AT 55-3/8"	38"
	26	10 LONG AT 40-3/4" PLUS 3 WIDE AT 55-3/8"	23"
	24"	7 LONG AT 40-3/4" PLUS 5 WIDE AT 55-3/8"	34"
	22	3 LONG AT 40-3/4" PLUS 8 WIDE AT 55-3/8"	31"
	20	LENGTHWISE LOAD ON PAGE 8 OR 22	46"
60'-8" CAR	34	CROSSWISE LOAD ON PAGE 10 OR 24	29"
	32	14 LONG AT 40-3/4" PLUS 2 WIDE AT 55-3/8"	37"
	30	10 LONG AT 40-3/4" PLUS 5 WIDE AT 55-3/8"	34"
	29	COMBINATION LOAD ON PAGE 6 OR 20	57" & 29"
	28	7 LONG AT 40-3/4" PLUS 7 WIDE AT 55-3/8"	46"
	28	6 LONG AT 40-3/4" PLUS 8 WIDE AT 55-3/8"	31"
	26	3 LONG AT 40-3/4" PLUS 10 WIDE AT 55-3/8"	43"
	26	2 LONG AT 40-3/4" PLUS 11 WIDE AT 55-3/8"	28"
	26	LENGTHWISE LOAD ON PAGE 8 OR 22	57"

\*THE COMBINATION LOAD ON PAGE 6 OR 20, MAY BE USED, IF DESIRED. STRUTS FOR THE COMBINATION LOAD WILL BE APPROXIMATELY 46" AND 29" LONG.

ROUTED DUNNAGE METHOD UNIT

CAR LENGTH	UNITS PER LAYER	LOAD PATTERN	APPROX STRUT LENGTH
40'-6" CAR	20	CROSSWISE LOAD ON PAGE 66 OR 80	60"
	20	9 LONG AT 42" PLUS 1 WIDE AT 55-3/8"	45"
	20	8 LONG AT 42" PLUS 2 WIDE AT 55-3/8"	30"
	18"	5 LONG AT 42" PLUS 4 WIDE AT 55-3/8"	45"
	18"	4 LONG AT 42" PLUS 5 WIDE AT 55-3/8"	32"
	16	LENGTHWISE LOAD ON PAGE 64 OR 78	37"
50'-6" CAR	26	CROSSWISE LOAD ON PAGE 66 OR 80	54"
	26	12 LONG AT 42" PLUS 1 WIDE AT 55-3/8"	39"
	26	11 LONG AT 42" PLUS 2 WIDE AT 55-3/8"	24"
	24	8 LONG AT 42" PLUS 4 WIDE AT 55-3/8"	39"
	24	7 LONG AT 42" PLUS 5 WIDE AT 55-3/8"	24"
	22	4 LONG AT 42" PLUS 7 WIDE AT 55-3/8"	39"
	20	LENGTHWISE LOAD ON PAGE 64 OR 78	47"
60'-8" CAR	32	CROSSWISE LOAD ON PAGE 66 OR 80	50"
	30	12 LONG AT 42" PLUS 3 WIDE AT 55-3/8"	48"
	30	11 LONG AT 42" PLUS 4 WIDE AT 55-3/8"	35"
	28"	7 LONG AT 42" PLUS 7 WIDE AT 55-3/8"	37"
	28"	6 LONG AT 42" PLUS 8 WIDE AT 55-3/8"	24"
	26	3 LONG AT 42" PLUS 10 WIDE AT 55-3/8"	39"
	26	2 LONG AT 42" PLUS 11 WIDE AT 55-3/8"	25"
	24	LENGTHWISE LOAD ON PAGE 64 OR 78	57"

\*THE COMBINATION LOAD ON PAGE 62 OR 76 MAY BE USED, IF DESIRED. STRUTS FOR THE COMBINATION LOAD WILL BE APPROXIMATELY 37" AND 60" LONG IN A 40'-6" LONG CAR, AND 57" AND 50" LONG IN A 60'-8" LONG CAR.

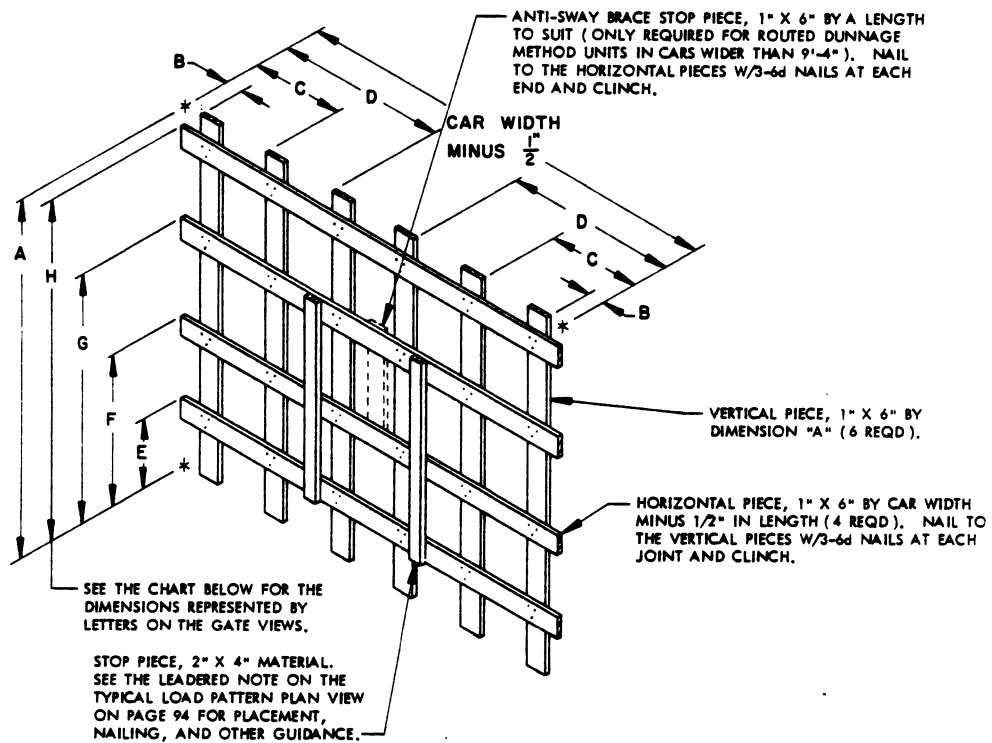

**SEPARATOR GATE N**

THIS VIEW DEPICTS A SEPARATOR GATE FOR A 2-HIGH LOAD, APPLICABLE TO ANY OF THE UNITS COVERED BY THIS DOCUMENT. SEE THE "END VIEW" BELOW FOR HEIGHT DIMENSIONS FOR THOSE UNITS WHICH CAN BE LOADED 3-HIGH.

HORIZONTAL PIECE, 1" X 6" BY CAR WIDTH MINUS 1/2" IN LENGTH (6 REQ'D). NAIL TO THE VERTICAL PIECES W/3-6d NAILS AT EACH JOINT AND CLINCH.

VERTICAL PIECE, 1" X 6" BY DIMENSION "J" (6 REQ'D).

PALLET UNIT NUMBER	DIMENSIONS										
	A	B	C	D	E	F	G	H	J	K	L
1	66"	4-1/2"	24-1/2"	44"	19"	28"	54"	63-1/2"	8'-6"	7'-6"	8'-3"
2	7'-2"	4-1/2"	24-1/2"	44"	19"	37"	63-1/2"	6'-11"	—	—	—
3	7'-8"	3-1/2"	23"	43"	20"	40"	69"	7'-5"	—	—	—
4	72"	3-1/2"	23"	43"	20"	30"	58"	68-1/2"	9'-2"	8'-1"	8'-11"
5	7'-8"	4-1/2"	24"	44"	19"	40"	67"	7'-4-1/2"	—	—	—
6	72"	4-1/2"	24"	44"	19"	29-1/2"	57"	67-1/2"	9'-0"	7'-11"	8'-9-1/2"

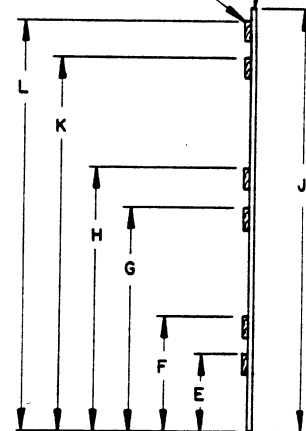

**END VIEW**

THIS VIEW DEPICTS A SEPARATOR GATE FOR A 3-HIGH LOAD WHICH IS ONLY APPLICABLE FOR UNITS 1, 4, AND 6 AS IDENTIFIED AT THE LEFT.

PALLET UNIT IDENTIFICATION	SHOWN AS UNIT NUMBER
ALTERNATED CONTAINERS ( BASIC HEIGHT )	1
ALTERNATED CONTAINERS ( INCREASED HEIGHT )	2
FLAT DUNNAGE METHOD ( BASIC HEIGHT )	3
FLAT DUNNAGE METHOD ( DECREASED HEIGHT )	4
ROUTED DUNNAGE METHOD ( BASIC HEIGHT )	5
ROUTED DUNNAGE METHOD ( DECREASED HEIGHT )	6

LENGTH OF PALLET UNIT.

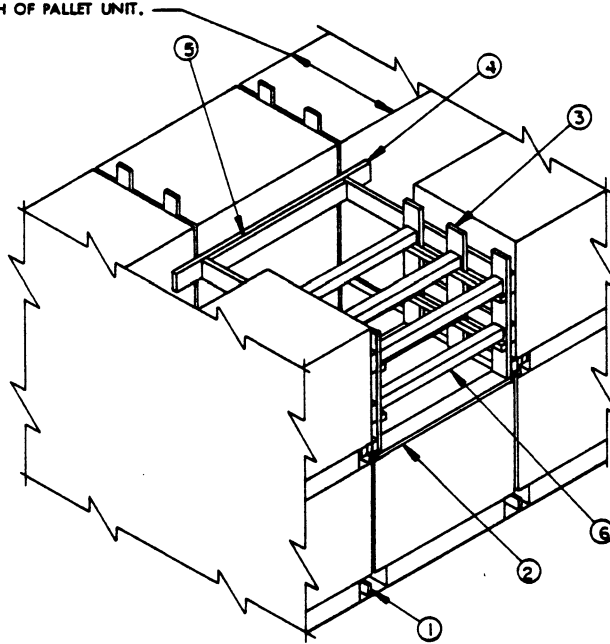

ISOMETRIC VIEW

SPECIAL NOTES:

1. A PARTIAL VIEW OF A 9'-2" WIDE CONVENTIONAL TYPE BOX CAR IS SHOWN. CARS OF OTHER WIDTHS CAN BE USED.
2. THE PALLET UNIT SHOWN IS THE ALTERNATED CONTAINERS UNIT (INCREASED HEIGHT). THE DEPICTED PROCEDURES ARE ALSO APPLICABLE FOR THE OTHER UNITS COVERED BY THIS DOCUMENT.
3. A UNIT OMITTED FROM THE TOP LAYER OF A 2-LAYER LOAD IS SHOWN AS TYPICAL. THE PROCEDURES ARE ALSO APPLICABLE FOR THE OMISSION OF A TOP-LAYER PALLET UNIT FROM A 3-LAYER LOAD.
4. THE OMITTED-UNIT PROCEDURE SHOULD BE APPLIED NEAR THE CENTER OF THE CAR LENGTH, BUT NOT IN THE DOORWAY AREA. ALSO, THERE SHOULD BE AT LEAST ONE (1) LOAD UNIT BETWEEN THE OMITTED UNIT AND A CENTER GATE.
5. ONLY THE BLOCKING AND BRACING FOR THE OMITTED UNIT IS SHOWN; REFER TO THE APPLICABLE LOAD PAGE FOR THE BLOCKING AND BRACING REQUIREMENTS FOR THE BALANCE OF THE LOAD.
6. NOTE THAT THE TOP HORIZONTAL PIECE OF EACH SEPARATOR GATE WHICH IS ADJACENT TO THE OMITTED UNIT AREA MUST BE 1" X 2" MATERIAL IN LIEU OF 1" X 4" AND MAY NEED TO BE ADJUSTED IN HEIGHT SO AS TO PROVIDE CLEARANCE BETWEEN IT AND THE CONTAINERS ON THE UNIT BELOW AS WELL AS CLEARANCE BETWEEN IT AND THE LOAD BEARING GATE, PIECE MARKED ③.

KEY NUMBERS

- ① MODIFIED SEPARATOR GATE (2 REQD). SEE THE APPLICABLE SEPARATOR GATE DETAIL ON PAGE 17, 31, 45, 59, 73 OR 87 FOR POSITIONING OF THE VERTICAL PIECES. SEE SPECIAL NOTE 6 AT LEFT FOR GATE MODIFICATIONS. POSITION GATE SO THE HORIZONTAL PIECES ARE AWAY FROM THE OMITTED UNIT AREA.
- ② SUPPORT PIECE, 2" X 6" X 55-3/8" (2 REQD). POSITION SO AS TO BE UNDER THE VERTICAL PIECES OF THE LOAD BEARING GATE, PIECE MARKED ③ (UNDER THE OUTWARD VERTICAL PIECES OF LOAD BEARING GATE "D").
- ③ LOAD BEARING GATE (2 REQD, 1 RIGHT HAND AND 1 LEFT HAND). SEE THE APPLICABLE DETAIL ON PAGE 98 OR 99. NAIL TO THE FILLER PIECE, PIECE MARKED ⑤, W/3-10d NAILS. TOENAIL TO THE SUPPORT PIECE, PIECE MARKED ②, W/2-10d NAILS AT EACH JOINT. CAUTION: USE CARE NOT TO TOENAIL INTO A CONTAINER.
- ④ ANTI-SWAY BEARING PIECE, 2" X 6" X 7'-0" (1 REQD).
- ⑤ FILLER PIECE, 2" X 6" X 54" (1 REQD). NAIL TO THE ANTI-SWAY BEARING PIECE, PIECE MARKED ④, W/5-10d NAILS.
- ⑥ STRUT, 4" X 4" BY CUT TO FIT (REF: 51") (AS REQD). TOENAIL TO PIECES MARKED ③ W/2-16d NAILS AT EACH END.



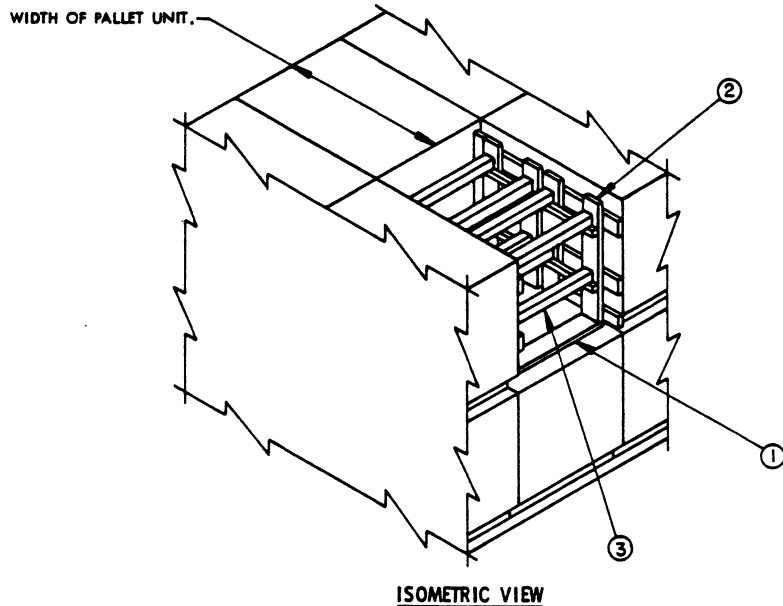

**SPECIAL NOTES:**

1. A PARTIAL VIEW OF A 9'-4" WIDE CONVENTIONAL TYPE BOX CAR IS SHOWN. WIDER CARS CAN BE USED.
2. THE PALLET UNIT SHOWN IS THE ALTERNATED CONTAINERS UNIT (INCREASED HEIGHT). THE DEPICTED PROCEDURES ARE ALSO APPLICABLE FOR THE OTHER UNITS COVERED BY THIS DOCUMENT.
3. A UNIT OMITTED FROM THE TOP LAYER OF A 2-LAYER LOAD IS SHOWN AS TYPICAL. THE PROCEDURES ARE ALSO APPLICABLE FOR THE OMISSION OF A TOP-LAYER PALLET UNIT FROM A 3-LAYER LOAD.
4. THE OMITTED-UNIT PROCEDURES SHOULD BE APPLIED NEAR THE CENTER OF THE CAR LENGTH, BUT NOT IN THE DOORWAY AREA. ALSO, THERE SHOULD BE AT LEAST ONE (1) LOAD UNIT BETWEEN THE OMITTED UNIT AND A CENTER GATE.
5. ONLY THE BLOCKING AND BRACING FOR THE OMITTED UNIT IS SHOWN. REFER TO THE APPLICABLE LOAD PAGE FOR THE BLOCKING AND BRACING REQUIREMENTS FOR THE BALANCE OF THE LOAD.

**KEY NUMBERS**

- ① SUPPORT PIECE, 2" X 6" BY UNIT LENGTH (2 REQD). POSITION BENEATH THE OUTSIDE 2" X 6" VERTICAL PIECES OF THE LOAD BEARING GATE, PIECE MARKED ②.
- ② LOAD BEARING GATE (2 REQD, 1 RIGHT HAND AND 1 LEFT HAND). SEE THE APPLICABLE DETAIL ON PAGE 100 OR 101. TOENAIL TO THE SUPPORT PIECE, PIECE MARKED ①, W/2-10d NAILS AT EACH JOINT. **CAUTION:** USE CARE NOT TO TOENAIL INTO A CONTAINER.
- ③ STRUT, 4" X 4" BY CUT TO FIT (AS REQD). TOENAIL TO PIECES MARKED ② W/2-16d NAILS AT EACH END.

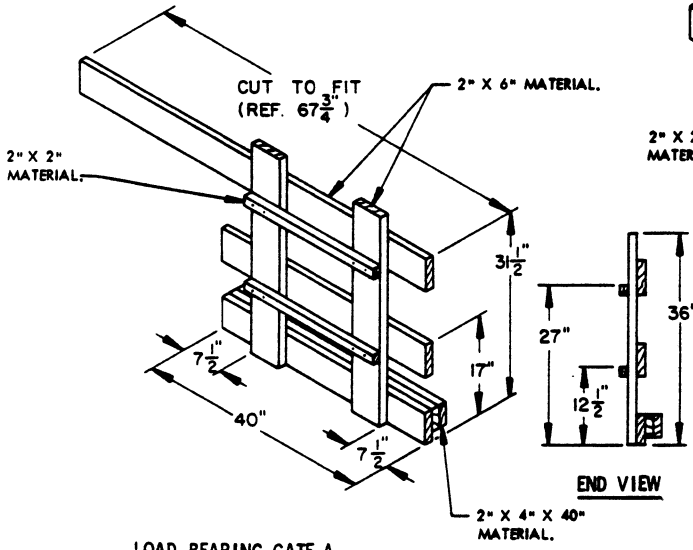

**LOAD BEARING GATE A**

THIS GATE IS FOR USE IN A LOAD OF ALTERNATED CONTAINERS UNITS ( BASIC HEIGHT ). SEE SPECIAL NOTE 3 BELOW FOR NAILING GUIDANCE. ONE RIGHT HAND AND ONE LEFT HAND GATE REQUIRED. A RIGHT HAND GATE IS SHOWN.

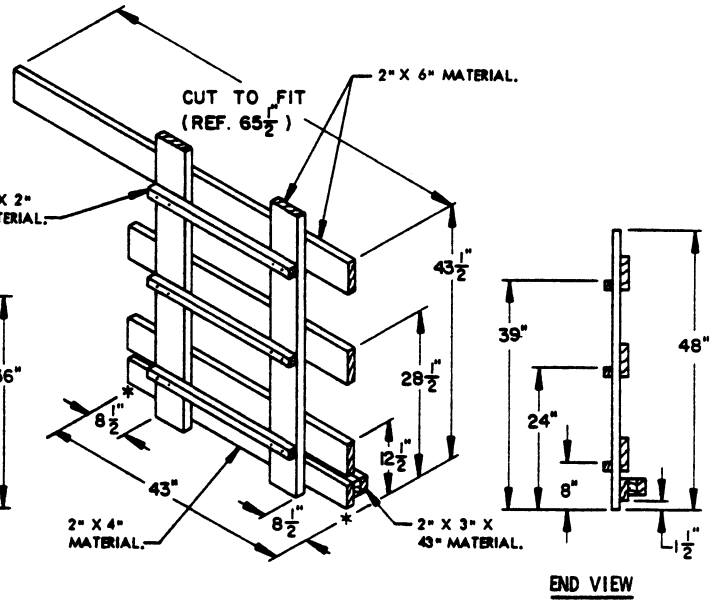

**LOAD BEARING GATE B**

THIS GATE IS FOR USE IN A LOAD OF FLAT DUNNAGE METHOD UNITS ( BASIC HEIGHT ), SEE SPECIAL NOTE 3 BELOW FOR NAILING GUIDANCE. ONE RIGHT HAND AND ONE LEFT HAND GATE REQUIRED. A RIGHT HAND GATE IS SHOWN.

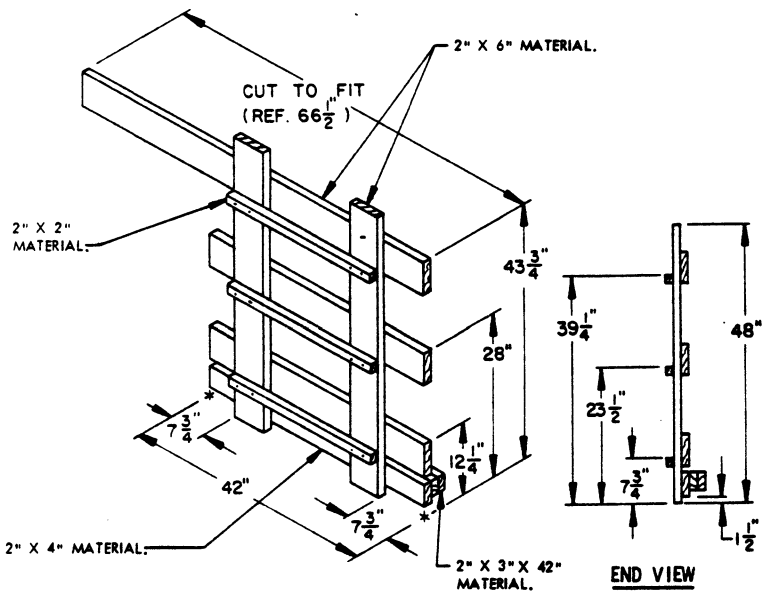

**LOAD BEARING GATE C**

THIS GATE IS FOR USE IN A LOAD OF Routed DUNNAGE METHOD UNITS ( BASIC HEIGHT ). SEE SPECIAL NOTE 3 AT RIGHT FOR NAILING GUIDANCE. ONE RIGHT HAND AND ONE LEFT HAND GATE REQUIRED. A RIGHT HAND GATE IS SHOWN.

**SPECIAL NOTES:**

1. THE GATES SHOWN ON THIS PAGE ARE FOR USE WITH BASIC-HEIGHT UNITS IN THE LCL PROCEDURES SHOWN ON PAGE 96. THOSE PROCEDURES DEPICT THE OMISSION OF A PALLET UNIT FROM A LOAD OF LENGTHWISE-POSITIONED PALLET UNITS.
2. THE REFERENCE DIMENSIONS GIVEN FOR THE CUT-TO-FIT PIECES ARE BASED ON AN INSIDE CAR WIDTH OF 9'-2". THESE DIMENSIONS WILL HAVE TO BE ADJUSTED WHEN LOADING CARS OF OTHER WIDTHS.
3. THE NAILING OF THE VARIOUS PARTS OF THE GATES WILL BE AS FOLLOWS: NAIL THE 2" X 4" OR 2" X 6" HORIZONTAL PIECE ( S ) TO THE 2" X 6" VERTICAL PIECES W/3-10d NAILS AT EACH JOINT. NAIL THE DOUBLED 2" X 4" OR 2" X 3" GATE HOLD DOWN PIECES TO A 2" X 4" OR 2" X 6" HORIZONTAL PIECE, AS APPLICABLE, W/5-10d NAILS EACH LAYER. NAIL THE 2" X 2" STRUT LEDGERS TO THE VERTICAL PIECES W/2-10d NAILS AT EACH END.

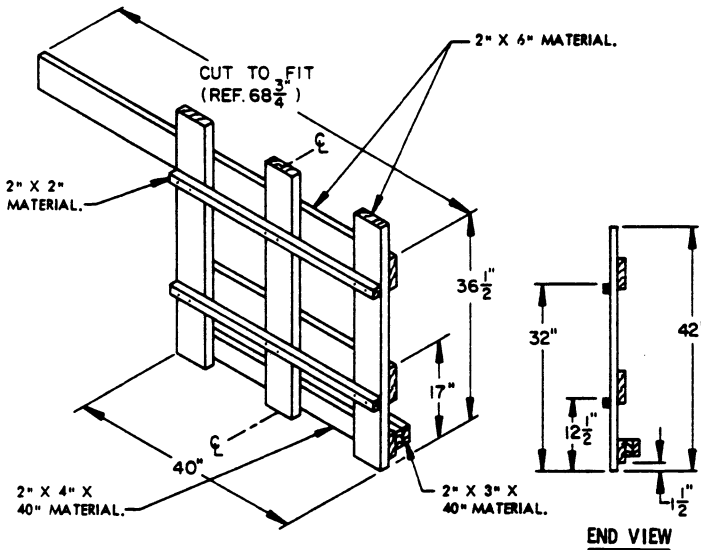

**LOAD BEARING GATE D**

THIS GATE IS FOR USE IN A LOAD OF ALTERNATED CONTAINERS UNITS (INCREASED HEIGHT). SEE SPECIAL NOTE 3 BELOW FOR NAILING GUIDANCE. ONE RIGHT HAND AND ONE LEFT HAND GATE REQUIRED. A RIGHT HAND GATE IS SHOWN.

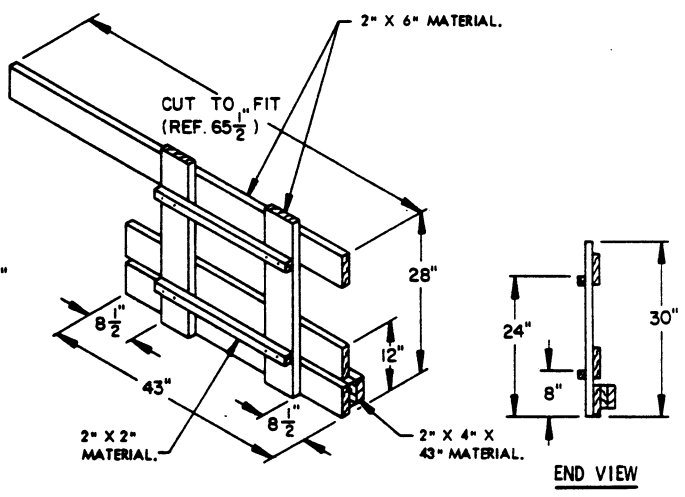

**LOAD BEARING GATE E**

THIS GATE IS FOR USE IN A LOAD OF FLAT DUNNAGE METHOD UNITS (DECREASED HEIGHT). SEE SPECIAL NOTE 3 BELOW FOR NAILING GUIDANCE. ONE RIGHT HAND AND ONE LEFT HAND GATE REQUIRED. A RIGHT HAND GATE IS SHOWN.

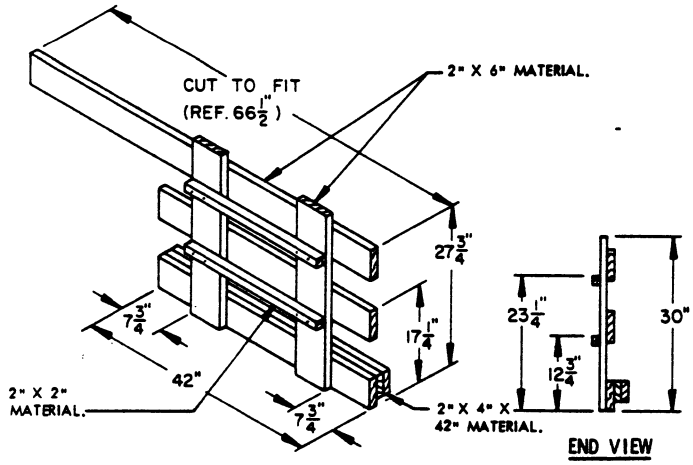

**LOAD BEARING GATE F**

THIS GATE IS FOR USE IN A LOAD OF ROUTED DUNNAGE METHOD UNITS (DECREASED HEIGHT). SEE SPECIAL NOTE 3 AT RIGHT FOR NAILING GUIDANCE. ONE RIGHT HAND AND ONE LEFT HAND GATE REQUIRED. A RIGHT HAND GATE IS SHOWN.

**SPECIAL NOTES:**

1. THE GATES SHOWN ON THIS PAGE ARE FOR USE WITH INCREASED AND/OR DECREASED-HEIGHT UNITS IN THE LCL PROCEDURES SHOWN ON PAGE 96. THOSE PROCEDURES DEPICT THE OMISSION OF A PALLET UNIT FROM A LOAD OF LENGTHWISE-POSITIONED PALLET UNITS.
2. THE REFERENCE DIMENSIONS GIVEN FOR THE CUT-TO-FIT PIECES ARE BASED ON AN INSIDE CAR WIDTH OF 9'-2". THESE DIMENSIONS WILL HAVE TO BE ADJUSTED WHEN LOADING CARS OF OTHER WIDTHS.
3. THE NAILING OF THE VARIOUS PARTS OF THE GATES WILL BE AS FOLLOWS: NAIL THE 2" X 4" OR 2" X 6" HORIZONTAL PIECE (S) TO THE VERTICAL PIECES W/3-10d NAILS AT EACH JOINT. NAIL THE DOUBLED 2" X 3" OR 2" X 4" GATE HOLD DOWN PIECES TO A 2" X 4" OR 2" X 6" HORIZONTAL PIECE, AS APPLICABLE, W/3-10d NAILS EACH LAYER. NAIL THE 2" X 2" STRUT LEDGERS TO THE VERTICAL PIECES W/2-10d NAILS AT EACH JOINT.

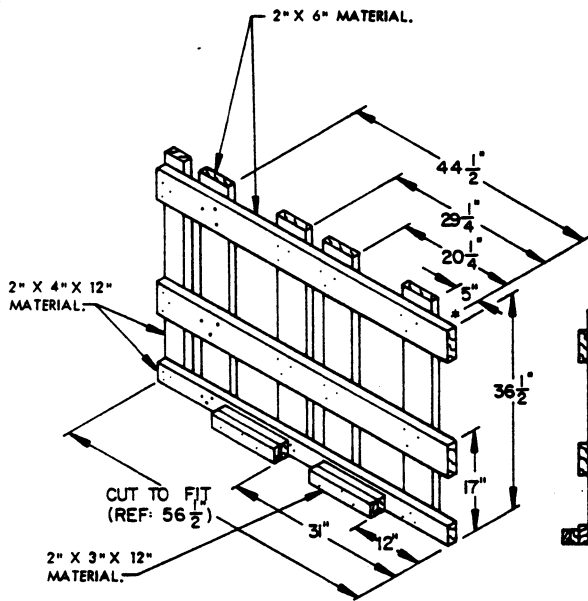

**LOAD BEARING GATE G**

THIS GATE IS FOR USE IN A LOAD OF ALTERNATED CONTAINERS UNITS (INCREASED HEIGHT). SEE SPECIAL NOTE 3 BELOW FOR NAILING GUIDANCE. ONE RIGHT HAND AND ONE LEFT HAND GATE REQUIRED. A RIGHT HAND GATE IS SHOWN.

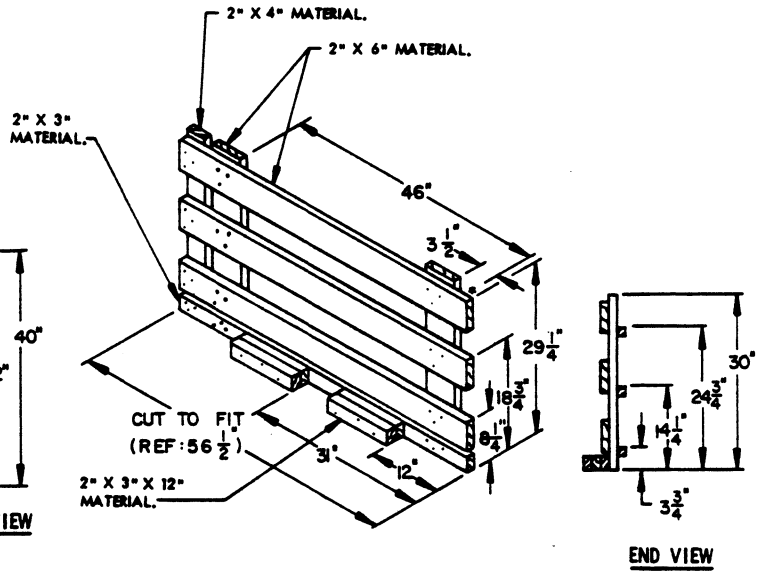

**LOAD BEARING GATE H**

THIS GATE IS FOR USE IN A LOAD OF FLAT DUNNAGE METHOD UNITS (DECREASED HEIGHT). SEE SPECIAL NOTE 3 BELOW FOR NAILING GUIDANCE. ONE RIGHT HAND AND ONE LEFT HAND GATE REQUIRED. A RIGHT HAND GATE IS SHOWN.

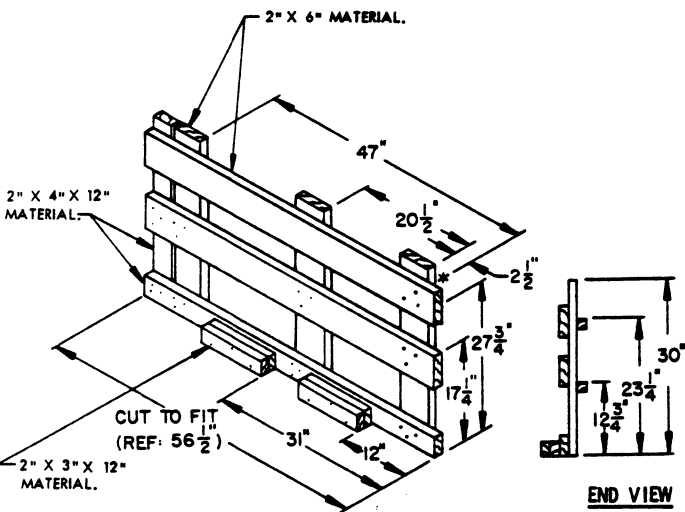

**LOAD BEARING GATE J**

THIS GATE IS FOR USE IN A LOAD OF ROUTED DUNNAGE METHOD UNITS (DECREASED HEIGHT). SEE SPECIAL NOTE 3 AT RIGHT FOR NAILING GUIDANCE. ONE RIGHT HAND AND ONE LEFT HAND GATE REQUIRED. A RIGHT HAND GATE IS SHOWN.

**SPECIAL NOTES:**

1. THE GATES ON THIS PAGE ARE FOR USE WITH BASIC-HEIGHT UNITS IN THE LCL PROCEDURES SHOWN ON PAGE 97. THOSE PROCEDURES DEPICT THE OMISSION OF A PALLET UNIT FROM A LOAD OF CROSSWISE-POSITIONED PALLET UNITS.
2. THE REFERENCE DIMENSION GIVEN FOR THE CUT-TO-FIT PIECES IS BASED ON AN INSIDE CAR WIDTH OF 9'-4". THIS DIMENSION WILL HAVE TO BE INCREASED WHEN LOADING WIDER CARS.
3. THE NAILING OF THE VARIOUS PARTS OF THE GATES WILL BE AS FOLLOWS: NAIL THE 2" X 3", 2" X 4", OR 2" X 6" HORIZONTAL PIECE (S) TO THE VERTICAL PIECES W/3-10d NAILS AT EACH JOINT. NAIL THE DOUBLED 2" X 3" GATE HOLD DOWN PIECES TO A HORIZONTAL PIECE W/3-10d NAILS EACH LAYER. NAIL THE 2" X 2" STRUT LEDGERS TO THE VERTICAL PIECES W/2-10d NAILS AT EACH JOINT.

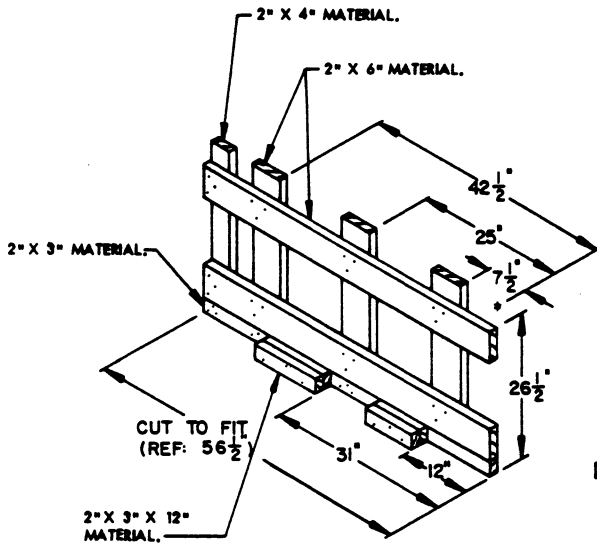

**LOAD BEARING GATE K**

THIS GATE IS FOR USE IN A LOAD OF ALTERNATED CONTAINERS UNITS (BASIC HEIGHT). SEE SPECIAL NOTE 3 BELOW FOR NAILING GUIDANCE. ONE RIGHT HAND AND ONE LEFT HAND GATE REQUIRED. A RIGHT HAND GATE IS SHOWN.

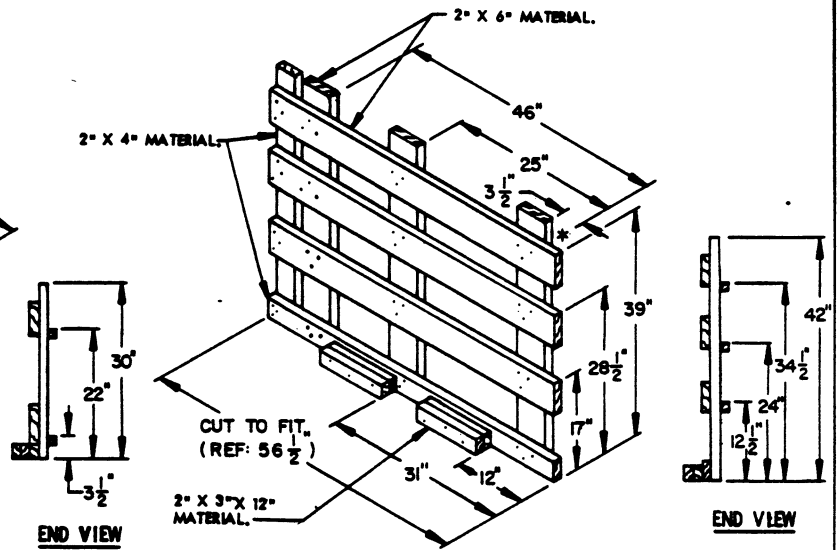

**LOAD BEARING GATE L**

THIS GATE IS FOR USE IN A LOAD OF FLAT DUNNAGE METHOD UNITS (DECREASED HEIGHT). SEE SPECIAL NOTE 3 BELOW FOR NAILING GUIDANCE. ONE RIGHT HAND AND ONE LEFT HAND GATE REQUIRED. A RIGHT HAND GATE IS SHOWN.

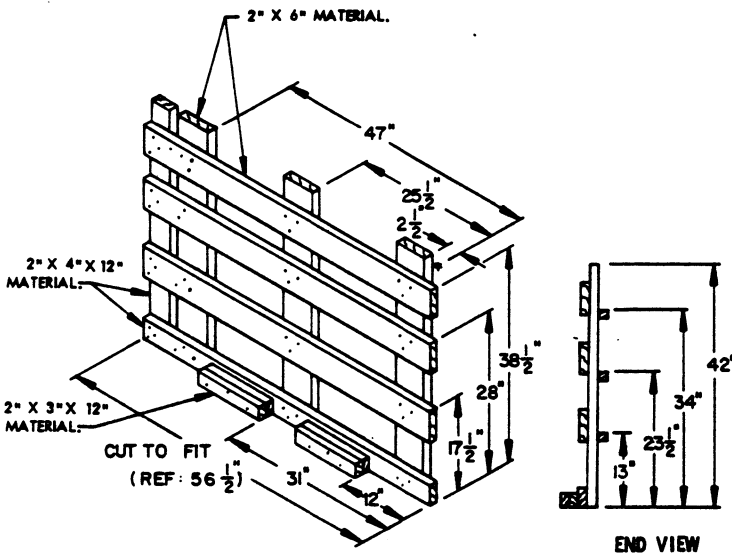

**LOAD BEARING GATE M**

THIS GATE IS FOR USE IN A LOAD OF ROUTED DUNNAGE METHOD UNITS (DECREASED HEIGHT). SEE SPECIAL NOTE 3 AT RIGHT FOR NAILING GUIDANCE. ONE RIGHT HAND AND ONE LEFT HAND GATE REQUIRED. A RIGHT HAND GATE IS SHOWN.

**SPECIAL NOTES:**

1. THE GATES ON THIS PAGE ARE FOR USE WITH INCREASED AND/OR DECREASED-HEIGHT UNITS IN THE LCL PROCEDURES SHOWN ON PAGE 97. THOSE PROCEDURES DEPICT THE OMISSION OF A PALLET UNIT FROM A LOAD OF CROSS-POSITIONED PALLET UNITS.
2. THE REFERENCE DIMENSION GIVEN FOR THE CUT-TO-FIT PIECES IS BASED ON AN INSIDE CAR WIDTH OF 9'-4". THIS DIMENSION WILL HAVE TO BE INCREASED WHEN LOADING WIDER CARS.
3. THE NAILING OF THE VARIOUS PARTS OF THE GATES WILL BE AS FOLLOWS: NAIL THE 2" X 3", 2" X 4", OR 2" X 6" HORIZONTAL PIECE (S) TO THE VERTICAL PIECES W/3-10d NAILS AT EACH JOINT. NAIL THE DOUBLED 2" X 3" GATE HOLD DOWN PIECES TO A HORIZONTAL PIECE W/3-10d NAILS EACH LAYER. NAIL THE 2" X 2" STRUT LEDGERS TO THE VERTICAL PIECES W/2-10d NAILS AT EACH JOINT.

EXCEPT FOR THE ALTERNATED CONTAINERS UNIT,  
THE DIRECTION OF THE ARROW INDICATES BASE END  
OF CONTAINERS. SEE GENERAL NOTE "E" ON PAGE 2.

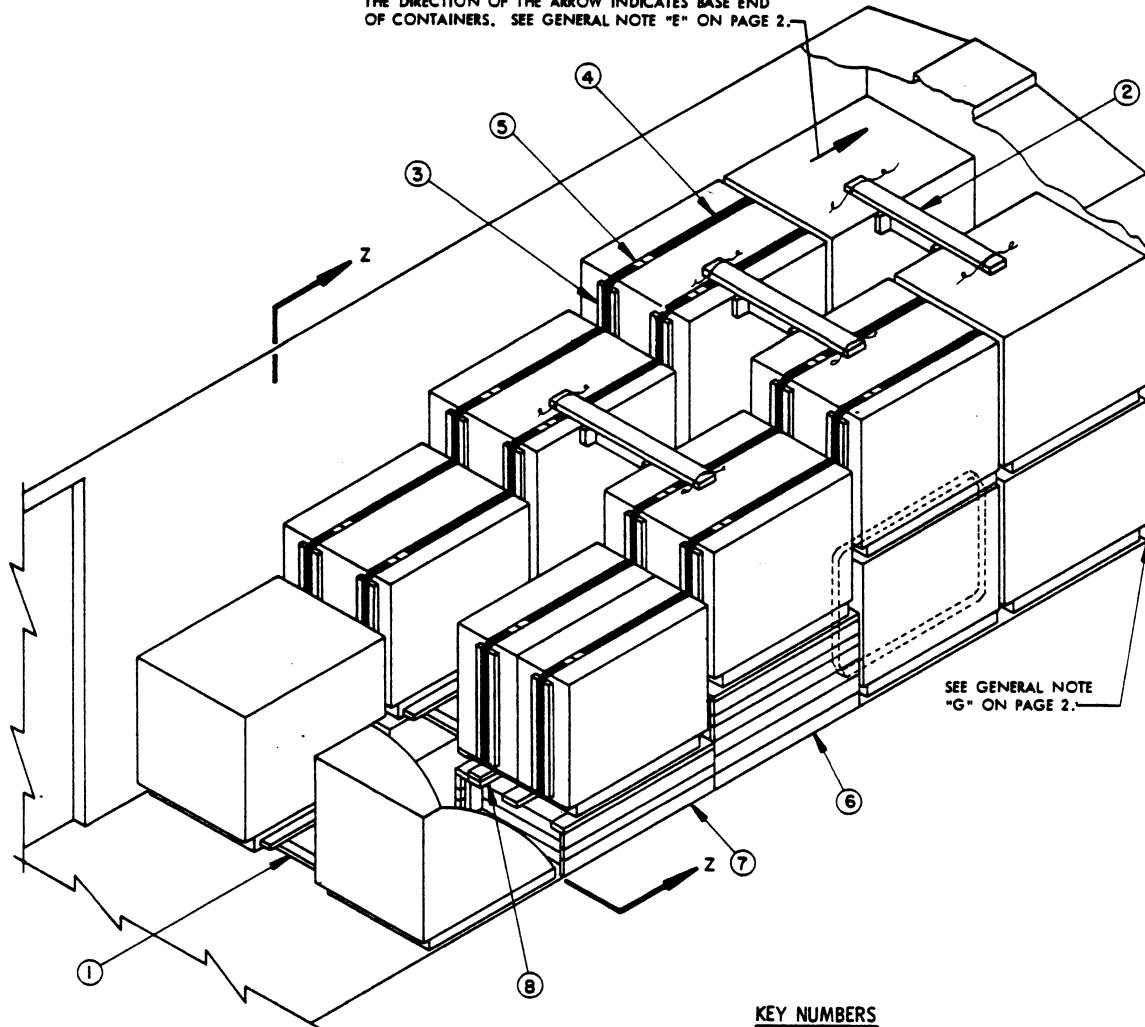

**ISOMETRIC VIEW**

**KEY NUMBERS**

- ① ANTI-SWAY BRACE (7 REQD). SEE THE "ANTI-SWAY BRACE A" DETAIL ON PAGE 18. INSTALL BETWEEN LATERALLY ADJACENT ROWS OF PALLET UNITS. SEE GENERAL NOTE "M" ON PAGE 2 AND SPECIAL NOTE 5 ON PAGE 103.
- ② TOP-OF-LOAD ANTI-SWAY BRACE (3 REQD). SEE THE "TOP-OF-LOAD ANTI-SWAY BRACE A" DETAIL ON PAGE 19 FOR THE ALTERNATED CONTAINERS UNIT OR THE "TOP-OF-LOAD ANTI-SWAY BRACE B" DETAIL ON PAGE 46 FOR THE FLAT OR ROUTED DUNNAGE METHOD UNITS. (TOP-OF-LOAD ANTI-SWAY BRACE B" IS SHOWN). WIRE TIE TO PALLET UNITS AS SHOWN BY THE APPLICABLE TIE WIRE APPLICATION DETAIL ON PAGE 122.
- ③ STRAPPING BOARD, 2" X 6" X 36" (32 REQD/4 PER PALLET UNIT). POSITION AS SHOWN IN THE "METHOD A" DETAIL ON PAGE 104. SEE SPECIAL NOTE 6 ON PAGE 103.
- ④ REINFORCING STRAP, 1-1/4" X .035" X 18'-0" LONG (REF) STEEL STRAPPING (16 REQD). INSTALL TO ENIRCLE THE PALLET UNIT AND THE STRAPPING BOARDS. SECURE TO A STRAPPING BOARD W/3 STAPLES. SEE THE "METHOD A" DETAIL ON PAGE 104.
- ⑤ SEAL FOR 1-1/4" STRAPPING (32 REQD/2 PER STRAP). DOUBLE CRIMP EACH SEAL. SEE GENERAL NOTE "N" ON PAGE 2.
- ⑥ RISER ASSEMBLY (2 REQD). THE HEIGHT OF THESE RISER ASSEMBLIES WILL BE TWO-THIRDS OF THE PALLET UNIT HEIGHT. SEE THE "RISER ASSEMBLY" DETAIL ON PAGE 103.
- ⑦ RISER ASSEMBLY (2 REQD). THE HEIGHT OF THESE RISER ASSEMBLIES WILL BE ONE-THIRD OF THE PALLET UNIT HEIGHT. SEE THE "RISER ASSEMBLY" DETAIL ON PAGE 103.
- ⑧ STOP PIECE "A" (4 REQD). SEE THE "RISER ASSEMBLY" DETAIL ON PAGE 103 FOR LOCATION AND NAILING GUIDANCE.

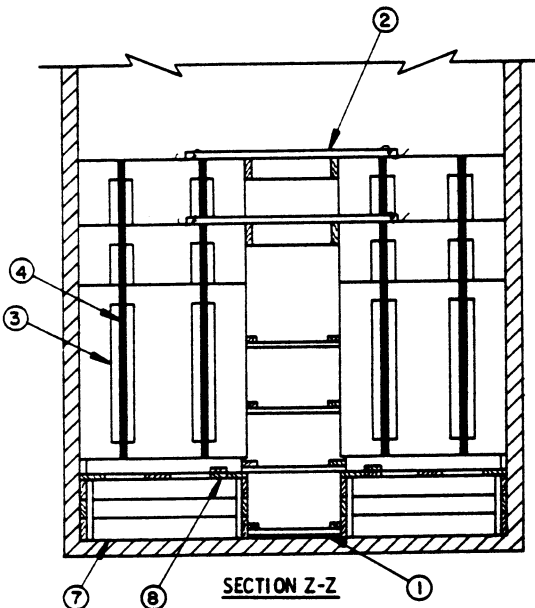

**SECTION Z-Z**

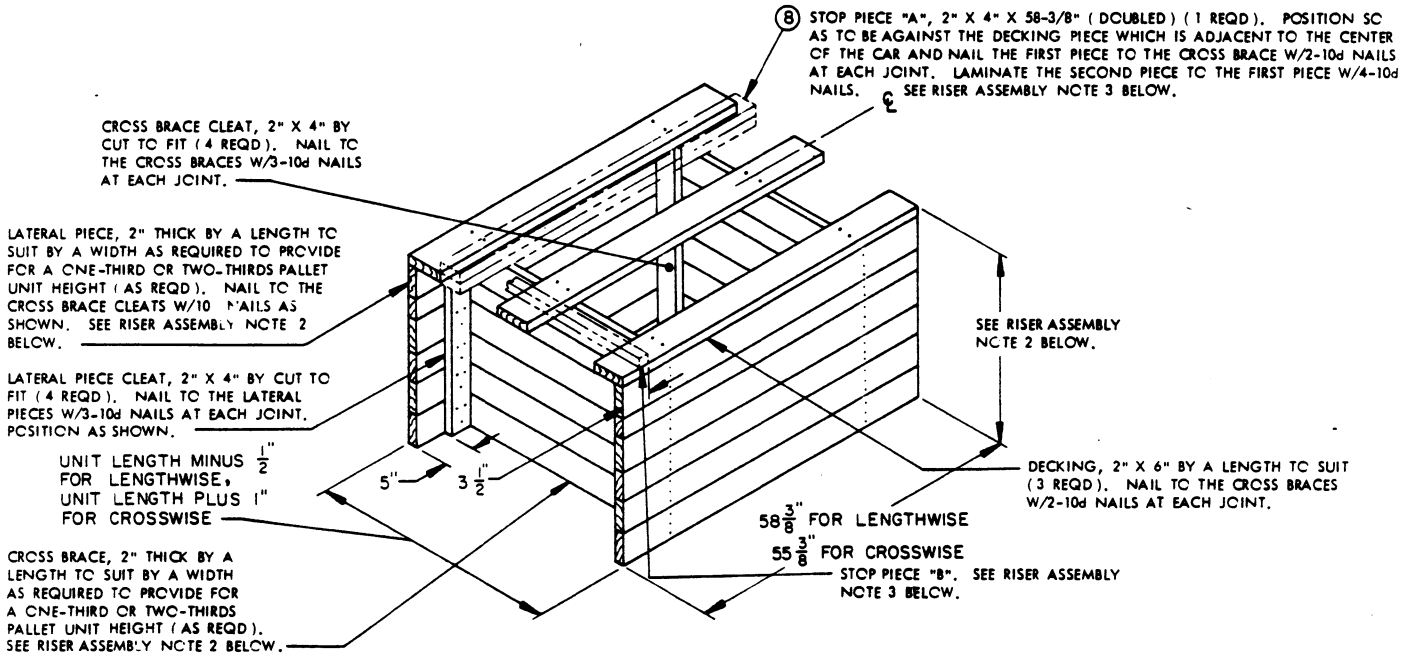

### RISER ASSEMBLY

#### SPECIAL NOTES FOR LOAD:

1. A 9'-2" WIDE CONVENTIONAL TYPE WOOD-LINED BOX CAR IS SHOWN. CARS OF OTHER WIDTHS CAN BE USED. SEE GENERAL NOTE "D" ON PAGE 2.
2. THE PALLET UNIT SHOWN IN THE TYPICAL LOAD ON PAGE 102 IS THE FLAT DUNNAGE METHOD UNIT (BASIC HEIGHT). THE DEPICTED PROCEDURES ARE ALSO APPLICABLE FOR THE OTHER UNITS COVERED BY THIS DOCUMENT.
3. THE RISER METHOD OF PARTIAL-LAYER BRACING IS TYPICALLY SHOWN WITH THE PALLET UNITS POSITIONED LENGTHWISE IN THE CAR. WITH MODIFICATIONS, THE PROCEDURES ARE ALSO APPLICABLE FOR CROSSWISE POSITIONED UNITS. SEE SPECIAL NOTES 5 AND 6.
4. ONLY THE BLOCKING AND BRACING FOR THE RISER METHOD OF PARTIAL-LAYER BRACING IS SHOWN. REFER TO THE APPLICABLE LOAD PAGE FOR THE BLOCKING AND BRACING REQUIREMENTS FOR THE BALANCE OF THE LOAD.
5. ANTI-SWAY BRACE "A" IS APPLICABLE FOR ALL THE LENGTHWISE POSITIONED UNITS. ANTI-SWAY BRACE "B", AS DETAILED ON PAGE 74, WILL BE USED FOR CROSSWISE POSITIONED ROUTED DUNNAGE METHOD UNITS IN CARS WIDER THAN 9'-4". ANTI-SWAY BRACING WILL NOT BE REQUIRED FOR THE OTHER UNITS, OR FOR THE ROUTED UNITS IN 9'-4" WIDE CARS.
6. FOR CROSSWISE POSITIONED UNITS, THE STRAPPING BOARDS SHOWN AS PIECES MARKED ③ WILL NOT BE REQUIRED. SEE THE "METHOD B", "METHOD C", AND "METHOD D" DETAILS ON PAGES 104 AND 105 FOR MODIFICATIONS TO BE ACCOMPLISHED IN LIEU OF USING STRAPPING BOARDS, WHEN THE PALLET UNITS ARE TO BE POSITIONED CROSSWISE IN THE CAR. ALSO, FOR LOADS OF CROSSWISE UNITS, STOP PIECE "B", AS SHOWN ON THE RISER DETAIL ABOVE, WILL BE USED IN LIEU OF STOP PIECE "A".

#### SPECIAL NOTES FOR RISER ASSEMBLY:

1. THE TYPICAL RISER ASSEMBLY SHOWN ABOVE IS FOR THE FLAT DUNNAGE METHOD UNIT (BASIC HEIGHT). THE HEIGHT OF THE BASIC UNIT IS 49". A TWO-THIRDS UNIT HEIGHT RISER IS SHOWN ABOVE AND AS KEY NUMBER ② IN THE LOAD ON PAGE 102. EACH CROSS BRACE AND EACH LATERAL PIECE OF THE RISER IS FABRICATED FROM FIVE (5) PIECES OF 2" X 6" MATERIAL AND ONE (1) PIECE OF 2" X 4" MATERIAL TO PROVIDE FOR A TOTAL HEIGHT OF 32-1/2" AFTER THE DECKING IS IN PLACE. A ONE-THIRD HEIGHT RISER, SHOWN AS KEY NUMBER ① IN THE LOAD ON PAGE 102, WILL BE FABRICATED FROM TWO (2) PIECES OF 2" X 6" AND ONE PIECE OF 2" X 4" MATERIAL FOR EACH CROSS BRACE AND EACH LATERAL PIECE, TO PROVIDE FOR A TOTAL HEIGHT OF 16" AFTER THE DECKING IS IN PLACE.
2. SELECT THE PROPER WIDTH COMBINATIONS FOR THE LATERAL/CROSS BRACE PIECES PRIOR TO CONSTRUCTING A RISER ASSEMBLY, TO ASSURE THAT THE TOTAL HEIGHT OF THE RISER ASSEMBLY IS ONE-THIRD OR TWO-THIRDS OF THE PALLET UNIT HEIGHT, BASED ON THE PALLET UNIT BEING LOADED AND THE LOCATION OF THE RISER ASSEMBLY WITHIN THE LOAD. NOTE: A PLUS OR MINUS 1" TOLERANCE IS PERMISSIBLE ON THE RISER HEIGHT.
3. THE STOP PIECE "A" SHOWN ON THE RISER ASSEMBLY ABOVE IS ONLY FOR USE WHEN THE PALLET UNITS ARE POSITIONED LENGTHWISE IN THE CAR, AS SHOWN IN THE LCL LOAD ON PAGE 102. IF THE PALLET UNITS ARE POSITIONED CROSSWISE IN THE CAR, POSITION A 2" X 2" BY A LENGTH TO SUIT PIECE ACROSS THE DECKING, ON THE END WHICH IS AGAINST THE CAR SIDEWALL, AND NAIL TO THE DECKING W/2-10d NAILS AT EACH JOINT. SEE STOP PIECE "B" ON THE RISER ASSEMBLY ABOVE FOR LOCATION GUIDANCE.

SEAL FOR 1-1/4" STRAPPING (4 REQD, 2 PER STRAP). SEE GENERAL NOTE "N" ON PAGE 2.

REINFORCING STRAP, 1-1/4" X .035" X 18'-0" LONG STEEL STRAPPING FOR 4-LAYER UNITS, 16'-0" LONG FOR 3-LAYER UNITS (2 REQD). INSTALL TO ENCIRCLE THE PALLET UNIT AND THE STRAPPING BOARDS. SECURE TO EACH STRAPPING BOARD W/3 STAPLES.

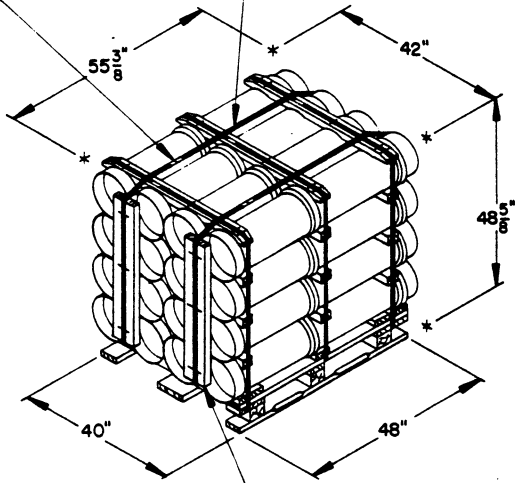

STRAPPING BOARD, 2" X 6" X 36" FOR 4-LAYER UNITS, 2" X 6" X 25-1/2" FOR 3-LAYER UNITS (4 REQD). POSITION SO AS TO CENTER ON THE JOINTS OF CONTAINERS.

**NOTE:**

THE "METHOD A" DETAIL AT LEFT SHOWS THE MODIFICATION REQUIRED FOR PALLET UNITS WHICH ARE TO BE POSITIONED LENGTHWISE IN A CAR WHEN USING THE RISER METHOD OF PARTIAL-LAYER BRACING SHOWN ON PAGE 102. THE BASIC HEIGHT ROUTED DUNNAGE METHOD UNIT IS SHOWN. THE PROCEDURES ARE APPLICABLE FOR ALL THE UNITS COVERED BY THIS DOCUMENT. FOR MODIFICATION OF UNITS TO BE POSITIONED CROSSWISE IN A CAR, REFER TO THE "METHOD B" DETAIL BELOW AND/OR THE "METHOD C" OR "METHOD D" DETAIL ON PAGE 105.

**METHOD A**

FOR ALL PALLET UNITS. THE ROUTED DUNNAGE METHOD UNIT (BASIC HEIGHT) IS SHOWN.

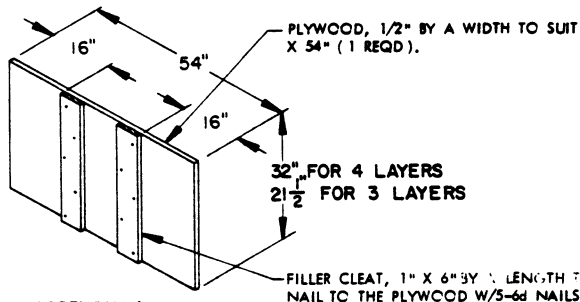

PLYWOOD, 1/2" BY A WIDTH TO SUIT X 54" (1 REQD).

32" FOR 4 LAYERS  
21 1/2" FOR 3 LAYERS

FILLER CLEAT, 1" X 6" BY A LENGTH TO SUIT (2 REQD). NAIL TO THE PLYWOOD W/5-6d NAILS AND CLINCH.

**SIDE FILL ASSEMBLY A**  
FOR METHOD "B" BELOW.

SEAL FOR 1-1/4" STRAPPING (4 REQD, 2 PER STRAP). SEE GENERAL NOTE "N" ON PAGE 2.

REINFORCING STRAP, 1-1/4" X .035" X 16'-0" LONG STEEL STRAPPING FOR 4-LAYER UNITS, 14'-6" FOR 3-LAYER UNITS (2 REQD). INSTALL TO ENCIRCLE THE PALLETIZED UNIT, THE STRAPPING BOARD, AND THE SIDE FILL ASSEMBLIES. SECURE TO THE STRAPPING BOARD AND THE SIDE FILL ASSEMBLIES W/STAPLES.

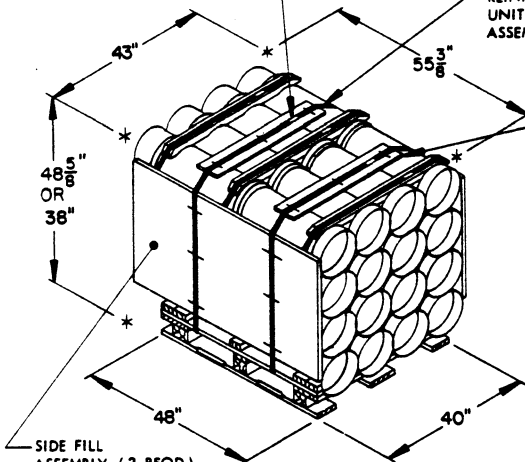

STRAPPING BOARD, 1" X 6" X 32" (2 REQD). POSITION AS SHOWN.

SIDE FILL ASSEMBLY (2 REQD). SEE THE "SIDE FILL ASSEMBLY A" DETAIL ABOVE.

**NOTE:**

THE "METHOD B" DETAIL AT LEFT SHOWS THE MODIFICATION REQUIRED FOR THE ROUTED DUNNAGE METHOD UNITS WHICH ARE TO BE POSITIONED CROSSWISE IN A CAR WHEN USING THE RISER METHOD OF PARTIAL-LAYER BRACING SHOWN ON PAGE 102. THE BASIC HEIGHT UNIT IS SHOWN, HOWEVER, THE PROCEDURE IS ALSO APPLICABLE FOR THE DECREASED HEIGHT UNIT. FOR MODIFICATION OF ROUTED DUNNAGE METHOD UNITS, TO BE POSITIONED LENGTHWISE IN A CAR, REFER TO THE "METHOD A" DETAIL ABOVE.

**METHOD B**

FOR ROUTED DUNNAGE METHOD UNITS. THE BASIC HEIGHT UNIT IS SHOWN.



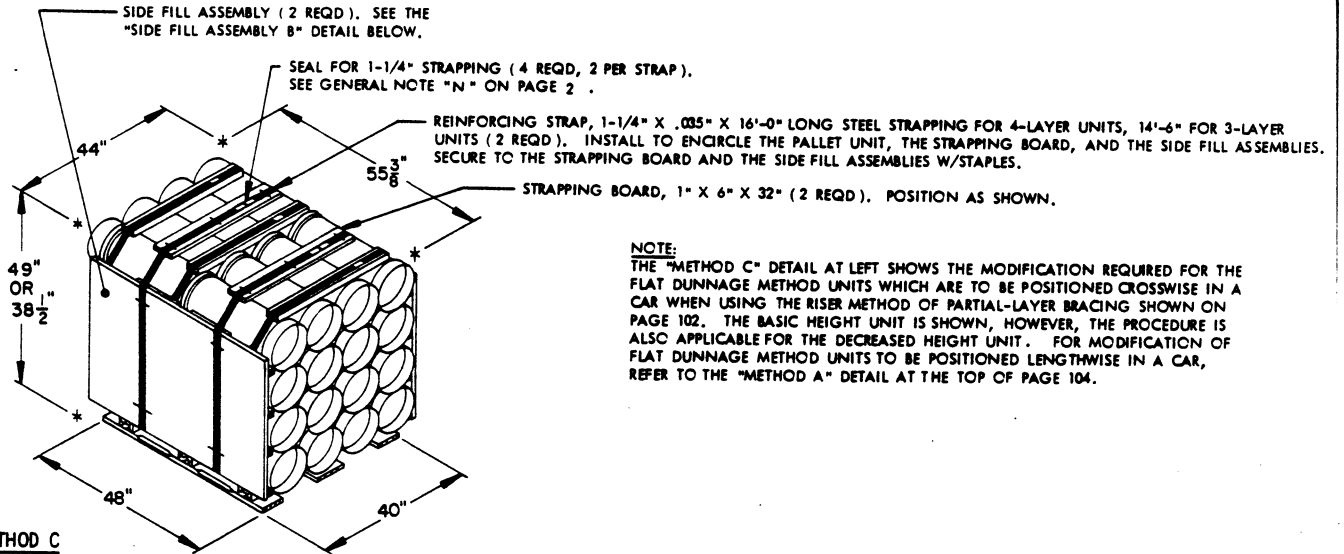

**NOTE:**  
 THE "METHOD C" DETAIL AT LEFT SHOWS THE MODIFICATION REQUIRED FOR THE FLAT DUNNAGE METHOD UNITS WHICH ARE TO BE POSITIONED CROSSWISE IN A CAR WHEN USING THE RISER METHOD OF PARTIAL-LAYER BRACING SHOWN ON PAGE 102. THE BASIC HEIGHT UNIT IS SHOWN, HOWEVER, THE PROCEDURE IS ALSO APPLICABLE FOR THE DECREASED HEIGHT UNIT. FOR MODIFICATION OF FLAT DUNNAGE METHOD UNITS TO BE POSITIONED LENGTHWISE IN A CAR, REFER TO THE "METHOD A" DETAIL AT THE TOP OF PAGE 104.

**METHOD C**  
 FOR FLAT DUNNAGE  
 METHOD UNITS.

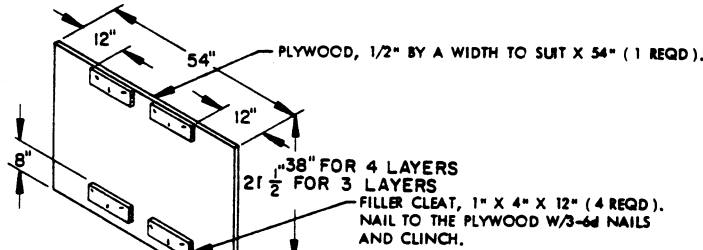

**SIDE FILL ASSEMBLY B**  
 FOR METHOD "C" ABOVE.

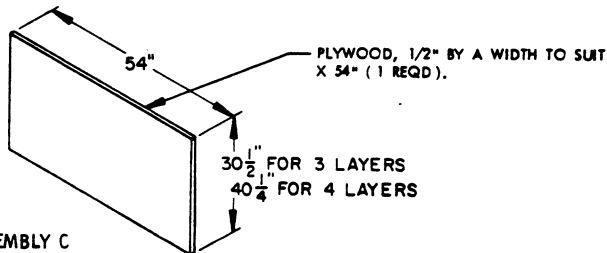

**SIDE FILL ASSEMBLY C**  
 FOR METHOD "D" BELOW.

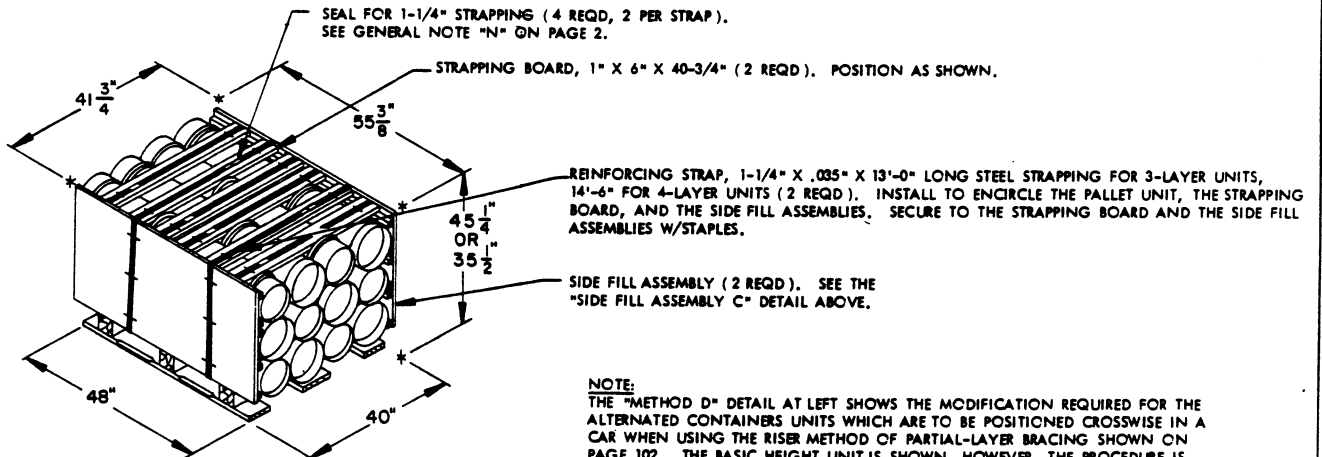

**NOTE:**  
 THE "METHOD D" DETAIL AT LEFT SHOWS THE MODIFICATION REQUIRED FOR THE ALTERNATED CONTAINERS UNITS WHICH ARE TO BE POSITIONED CROSSWISE IN A CAR WHEN USING THE RISER METHOD OF PARTIAL-LAYER BRACING SHOWN ON PAGE 102. THE BASIC HEIGHT UNIT IS SHOWN, HOWEVER, THE PROCEDURE IS ALSO APPLICABLE FOR THE INCREASED HEIGHT UNIT. FOR MODIFICATION OF ALTERNATED CONTAINERS UNITS TO BE POSITIONED LENGTHWISE IN A CAR, REFER TO THE "METHOD A" DETAIL AT THE TOP OF PAGE 104.

**METHOD D**  
 FOR ALTERNATED CONTAINERS  
 UNITS.

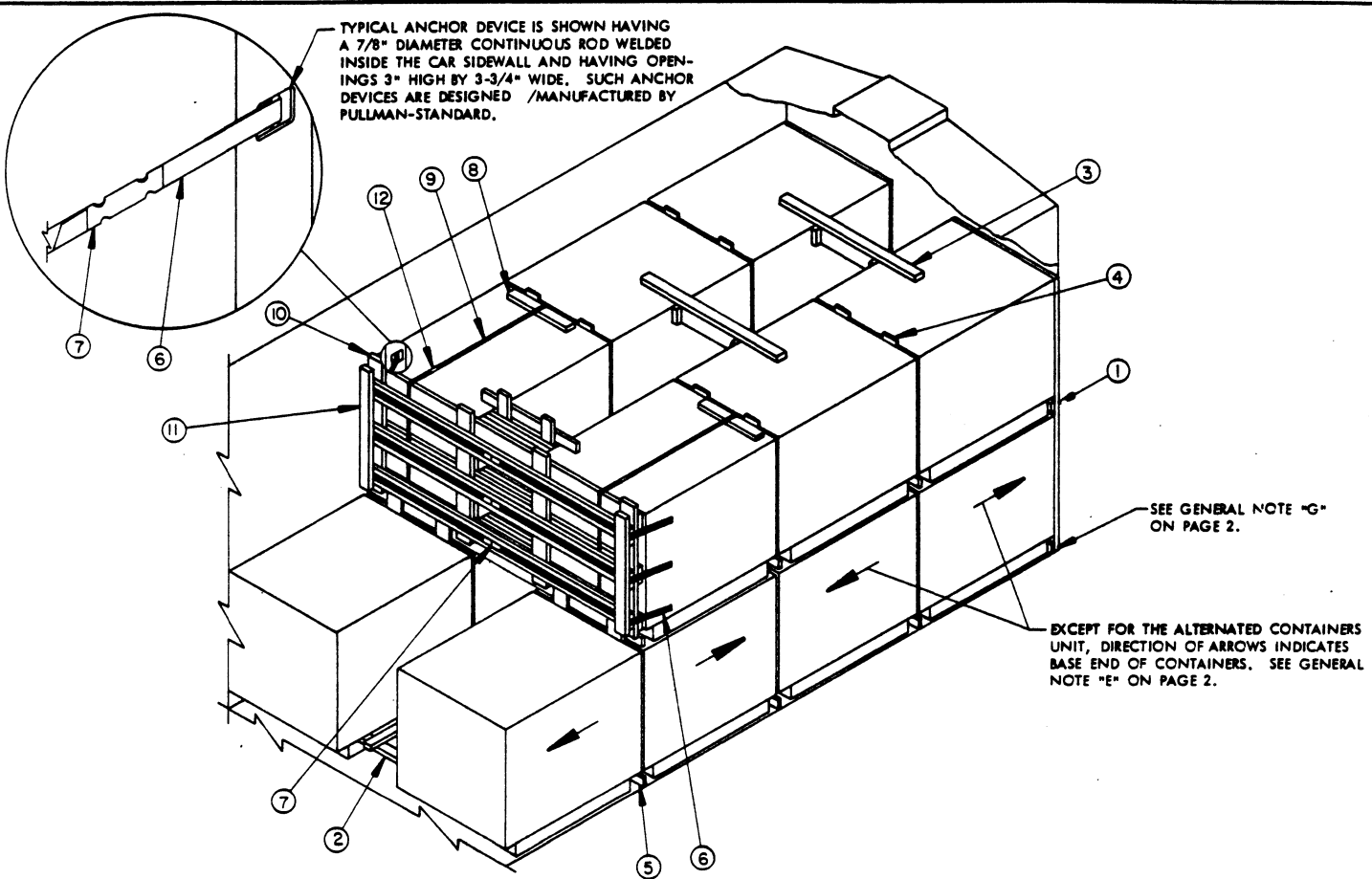

**ISOMETRIC VIEW**

**SPECIAL NOTES:**

1. A 9'-4" WIDE ALL-METAL BOX CAR EQUIPPED WITH STRAP ANCHOR DEVICES AND HAVING AN AAR MECHANICAL DESIGNATION CLASS OF XL IS SHOWN. CARS OF OTHER WIDTHS CAN BE USED.
2. THE PALLET UNIT SHOWN IN THE TYPICAL LCL LOAD IS THE ROUTED DUNNAGE METHOD UNIT (BASIC HEIGHT). THE DEPICTED PROCEDURES ARE ALSO APPLICABLE FOR THE OTHER UNITS COVERED BY THIS DOCUMENT.
3. THE BULKHEAD GATE METHOD OF PARTIAL-LAYER BRACING IS ONLY APPLICABLE FOR USE IN LOADS OF LENGTHWISE POSITIONED PALLET UNITS AS SHOWN IN THE VIEW ABOVE. PARTIAL LAYERS OF CROSSWISE POSITIONED PALLET UNITS WILL NOT BE RETAINED BY THE BULKHEAD GATE METHOD.
4. A BULKHEAD GATE USED IN CONJUNCTION WITH THREE (3) BULKHEAD STRAPS WILL RETAIN UP TO 18,000 POUNDS OF LADING; A BULKHEAD GATE WITH TWO (2) STRAPS WILL RETAIN NOT MORE THAN 12,000 POUNDS. IF ONLY TWO STRAPS ARE USED, THEY MUST BE APPLIED OVER THE UPPER AND LOWER STRAPPING BOARDS.
5. THE ANCHOR DEVICES TO BE USED FOR THE ATTACHMENT OF THE BULKHEAD STRAPS MUST BE LOCATED AT LEAST SIX INCHES (6") TOWARD THE CAR END WALL FROM THE OPPOSITE-THE-LOAD SIDE OF THE BULKHEAD GATE.
6. BULKHEAD STRAPS WILL BE TWO INCH (2") WIDE STEEL STRAPPING; 1-1/4" STRAPPING MUST NOT BE USED. A BULKHEAD STRAP WILL BE OF A LENGTH TO SUIT AND WILL BE THREADED THRU THE ANCHOR DEVICE (PRIOR TO POSITIONING THE ADJACENT UNITS) FAR ENOUGH TO PROVIDE FOR ONE LEG BEING APPROXIMATELY 48" LONGER THAN THE OTHER. THE STRAP ATTACHED TO THE MATING ANCHOR DEVICE WILL HAVE THE OPPOSITE LEG EXTENDING 48". THE TWO LEGS OF EACH HALF OF A STRAP WILL BE SECURED NEAR THE ANCHOR DEVICE WITH ONE DOUBLE CRIMPED SEAL. NOTE THAT THIS SEAL MUST BE POSITIONED EITHER CLOSE ENOUGH TO OR FAR ENOUGH AWAY FROM THE ANCHOR DEVICE SO AS NOT TO BE AT THE POINT WHERE THE STRAP BENDS AROUND THE END OF THE BULKHEAD GATE OR AROUND THE CORNER OF THE ADJACENT UNIT. THE STRAP ENDS OF EACH PAIR OF LONG AND SHORT LEGS WILL BE SECURED WITH TWO (2) SEALS BUTTED TOGETHER AND DOUBLE CRIMPED.

(CONTINUED ON PAGE 107)

**KEY NUMBERS**

- ① END-WALL LINING (1 REQD). SEE THE DETAIL ON PAGE 121. SEE GENERAL NOTE "D" ON PAGE 2. NOTE THAT IF AN END-OF-CAR BULKHEAD, AS DETAILED ON PAGE 122 IS USED, THE END-WALL LINING IS NOT REQUIRED.
- ② ANTI-SWAY BRACE (7 REQD). SEE THE "ANTI-SWAY BRACE A" DETAIL ON PAGE 18. INSTALL BETWEEN THE LATERALLY ADJACENT ROWS OF PALLET UNITS. SEE GENERAL NOTE "M" ON PAGE 2.
- ③ TOP-OF-LOAD ANTI-SWAY BRACE (2 REQD). SEE THE TOP-OF-LOAD ANTI-SWAY BRACE A" DETAIL ON PAGE 19 FOR THE ALTERNATED CONTAINERS UNIT OR THE "TOP-OF-LOAD ANTI-SWAY BRACE B" DETAIL ON PAGE 46 FOR THE FLAT OR ROUTED DUNNAGE METHOD UNITS. WIRE TIE TO PALLET UNITS AS SHOWN BY THE APPLICABLE TIE WIRE APPLICATION DETAIL ON PAGE 122.
- ④ SEPARATOR GATE FOR 2-HIGH LOAD (2 REQD). SEE THE APPLICABLE DETAIL ON PAGE 17, 31, 45, 59, 73, OR 87 AND/OR THE "ALTERNATIVE SEPARATOR GATE" DETAIL ON PAGE 122. POSITION WITH THE HORIZONTAL PIECES AGAINST THE ALREADY-LOADED UNITS.
- ⑤ SEPARATOR GATE FOR 1-HIGH LOAD (1 REQD). SEE THE APPLICABLE DETAIL ON THE AFOREMENTIONED PAGES.
- ⑥ BULKHEAD STRAP, 2" X .050" X 23'-0" LONG (REF) STEEL STRAPPING (3 REQD). INSTALL FROM 2 EQUAL LENGTH PIECES. SEE THE "STRAP APPLICATION PLAN VIEW" ON PAGE 107 FOR INSTALLATION GUIDANCE. SEE SPECIAL NOTES 4 THROUGH 6 AT LEFT.
- ⑦ SEAL FOR 2" STRAPPING (18 REQD, 6 PER STRAP). DOUBLE CRIMP EACH SEAL. SEE GENERAL NOTE "N" ON PAGE 2.
- ⑧ STRAPPING BOARD (2 REQD). SEE THE DETAIL ON PAGE 107.
- ⑨ BUNDLING STRAP, 1-1/4" X .035" X 19'-0" LONG (REF) STEEL STRAPPING (2 REQD). ENCIRCLE THE PALLET UNIT, THE HORIZONTAL PIECES OF THE BULKHEAD GATE, AND A STRAPPING BOARD, PIECE MARKED ⑧. TENSION AND SEAL AFTER TENSIONING THE BULKHEAD STRAPS, PIECES MARKED ⑥.
- ⑩ BULKHEAD GATE (1 REQD). SEE THE DETAIL ON PAGE 107. SEE SPECIAL NOTE 3 AT LEFT.
- ⑪ STRAP RETAINER, 2" X 4" BY A LENGTH TO SUIT (2 REQD). NAIL TO THE BULKHEAD GATE W/2-12d NAILS ABOVE AND BELOW EACH BULKHEAD STRAP.
- ⑫ SEAL FOR 1-1/4" STEEL STRAPPING (2 REQD, 1 PER STRAP). DOUBLE CRIMP EACH SEAL.

7. THE STRAPPING BOARDS ON A BULKHEAD GATE ARE TO BE ALIGNED AS NEARLY AS POSSIBLE WITH THE ANCHOR DEVICES IN THE CAR TO WHICH THE BULKHEAD STRAPS ARE ATTACHED. TOLERANCES ARE SPECIFIED ON THE END VIEW OF THE BULKHEAD GATE BELOW FOR THE LOCATION OF THE STRAPPING BOARDS. THE STRAPPING BOARDS/HORIZONTAL PIECES SHOULD BE LOCATED WITHIN THESE TOLERANCES. IF THIS IS NOT POSSIBLE, ADDITIONAL HORIZONTAL PIECES MUST BE APPLIED, AS NECESSARY TO PROVIDE PROPER BEARING AGAINST THE CONTAINERS.

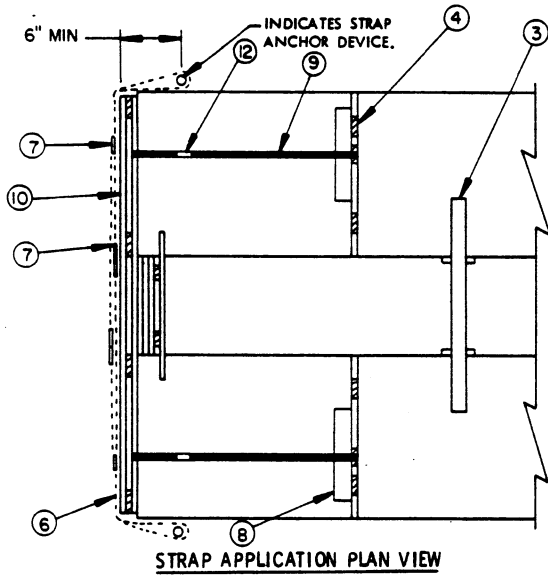

HORIZONTAL PIECE LOCATION				
UNIT	3-HIGH		4-HIGH	
	DIM A	DIM B	DIM A	DIM B
ALTERNATED CONTAINERS	13" ± 5"	22" ± 5"	17" ± 1"	32" ± 5"
FLAT DUNNAGE	12-1/2" ± 5"	23" ± 5"	18" ± 1"	34" ± 5"
ROUTED DUNNAGE	12-1/2" ± 5"	23" ± 5"	18" ± 1"	34" ± 5"

VERTICAL PIECE, 1" X 6" BY UNIT HEIGHT MINUS 5" (1 REQD). NAIL TO THE HORIZONTAL PIECE W/3-6d NAILS.

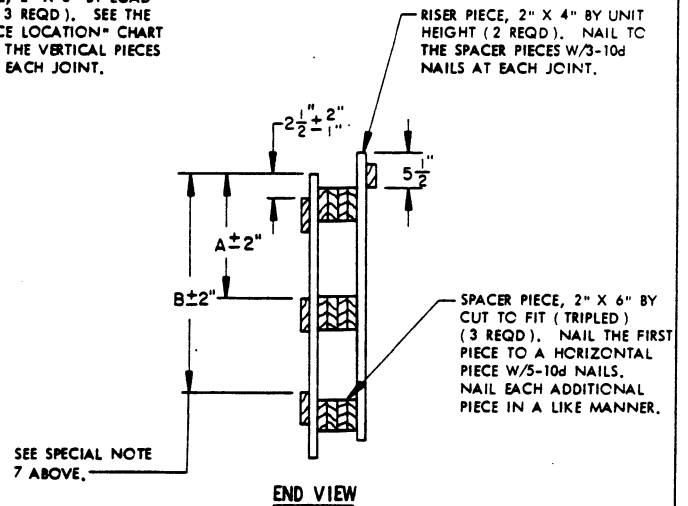
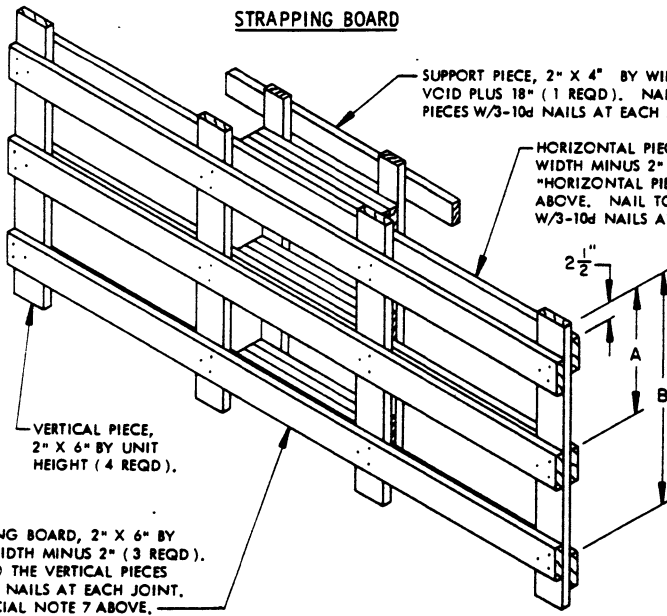
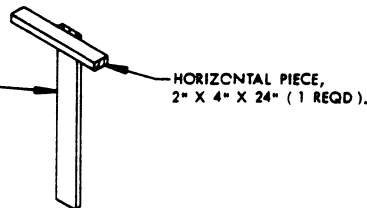

ADJACENT PIECE MARKED ⑨ MUST BE DOUBLED AND EXTENDED ACROSS AND FAR ENOUGH PAST THE DOOR OPENING ( REF: 60" ), TO PROVIDE FOR THE SPECIFIED NAILING OF EACH PIECE. LAMINATE THE SECOND PIECE OF THE DOUBLED PIECE MARKED ⑨ TO THE FIRST W/16-16c NAILS. CLINCH THOSE NAILS WHICH PROTRUDE THRU THE HORIZONTAL WALL CLEAT WITHIN THE DOOR OPENING. NOTE THAT THE DIAGONAL BRACE WILL BE 49-1/8" LONG IN LIEU OF 50-1/4" WHEN PIECE MARKED ⑨ IS DOUBLED.

6. THE CENTER CLEAT, SHOWN AS PIECE MARKED ⑦, WILL 28" LONG FOR AN 8'-6" WIDE CAR, 36" LONG FOR A 9'-2", AND 38" LONG FOR A 9'-4" WIDE CAR. ADJUST THE LENGTH PROPORTIONATELY FOR CARS OF OTHER WIDTHS.

IF THE CAR HAS A BOWED END WALL, A BULKHEAD MUST BE INSTALLED. SEE THE "END-OF-CAR BULKHEAD" DETAIL ON PAGE 122.

EXCEPT FOR THE ALTERNATED CONTAINERS UNIT, DIRECTION OF ARROW INDICATES BASE END OF CONTAINER. SEE GENERAL NOTE "E" ON PAGE 2.

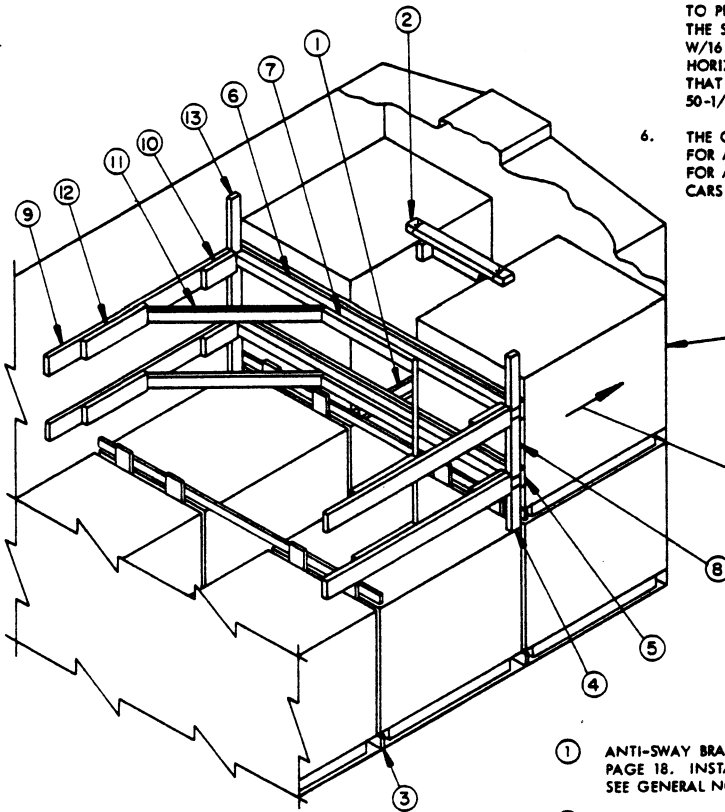

ISOMETRIC VIEW

SPECIAL NOTES:

1. A 9'-2" WIDE CONVENTIONAL WOOD-LINED BOX CAR IS SHOWN. WOOD-LINED CARS OF OTHER WIDTHS CAN BE USED.
2. THE PALLET UNIT SHOWN IN THE TYPICAL LCL LOAD IS THE ROUTED DUNNAGE METHOD UNIT ( BASIC HEIGHT ). THE DEPICTED PROCEDURES ARE ALSO APPLICABLE FOR THE OTHER UNITS COVERED BY THIS DOCUMENT.
3. PARTIAL-LAYER BRACING MAY BE APPLIED FOR ANY OF THE CONVENTIONAL CARLOADS DEPICTED HEREIN EXCEPT THE COMBINATION LOADS ( 1 ROW LENGTHWISE AND 1 ROW CROSSWISE ). A LENGTHWISE LOAD IS SHOWN AS TYPICAL. THE BLOCKING AND BRACING WILL VARY FOR CROSSWISE LOADS. NOTE THAT FOR A CROSSWISE PARTIAL TIER, THE PIECES MARKED ⑤ SHOULD BE LOCATED SO AS TO BEAR AGAINST THE PALLET UNITS IN THE SAME LOCATION AS THE HORIZONTAL PIECES OF A CENTER GATE.
4. THE K-BRACE METHOD OF PARTIAL-LAYER ( TIER ) BRACING SHOWN MAY BE USED IN WOOD-LINED CARS FOR THE SECUREMENT OF A PARTIAL TOP TIER, BE IT A SECOND TIER, THIRD TIER, OR FIRST. THE TYPE "A" K-BRACE SHOWN IS ADEQUATE FOR RETAINING A PARTIAL TIER OF NOT MORE THAN 8,000 POUNDS. IF IT IS NECESSARY TO BLOCK A HEAVIER LOAD, REFER TO THE DETAILS ON PAGES 109, 110, AND 111 FOR SELECTION OF THE APPLICABLY SIZED K-BRACE TO USE AND THE DESIGN SPECIFICATIONS FOR THE BRACE.
5. CAUTION: SOME CARS ARE NOT SUITED FOR THE APPLICATION OF "PARTIAL-LAYER BRACING" BECAUSE THE LENGTH OF THE PARTIAL TIER TO BE SHIPPED AND/OR THE SIZE OR CONFIGURATION OF THE CAR DOORS WILL NOT PERMIT PROPER INSTALLATION OF THE SPECIFIED K-BRACE DUNNAGE. PIECES MARKED ④, ⑤, ⑥, ⑧, ⑩, AND ⑬ MUST BE SUPPORTED AT THE SIDES OF A CAR BY A CAR SIDEWALL. IT IS ALLRIGHT FOR THE ENDS OF THE DIAGONAL BRACES MARKED ⑪ TO BEAR IN FRONT OF A DOOR OPENING, HOWEVER, THE

( CONTINUED AT RIGHT ABOVE )

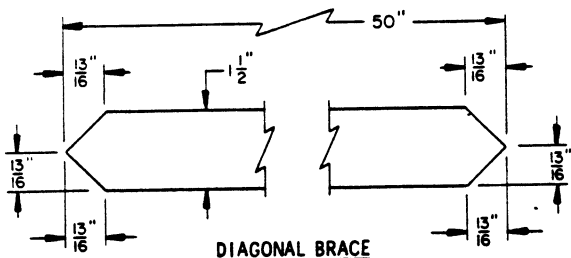

DIAGONAL BRACE

KEY NUMBERS

- ① ANTI-SWAY BRACE ( 2 REQD ). SEE THE "ANTI-SWAY BRACE A" DETAIL ON PAGE 18. INSTALL BETWEEN LATERALLY ADJACENT ROWS OF PALLET UNITS. SEE GENERAL NOTE "M" ON PAGE 2 AND SPECIAL NOTE 3 AT LEFT.
- ② TOP-OF-LOAD ANTI-SWAY BRACE ( 1 REQD ). SEE THE "TOP-OF-LOAD ANTI-SWAY BRACE A" DETAIL ON PAGE 19 FOR THE ALTERNATED CONTAINERS UNIT OR THE "TOP-OF-LOAD ANTI-SWAY BRACE B" DETAIL ON PAGE 46 FOR THE FLAT OR ROUTED DUNNAGE METHOD UNITS. WIRE TIE TO PALLET UNITS AS SHOWN BY THE APPLICABLE TIE WIRE APPLICATION DETAIL ON PAGE 122. NOTE THAT THE QUANTITY IS ONLY FOR THE PARTIAL-TIER UNITS.
- ③ SEPARATOR GATE ( 2 REQD ). SEE THE APPLICABLE DETAIL ON PAGE 17, 31, 45, 59, 73, OR 87 AND/OR THE "ALTERNATIVE SEPARATOR GATE" DETAIL ON PAGE 122.
- ④ SUPPORT CLEAT, 2" X 4" X 12" ( 2 REQD ). NAIL TO THE CAR SIDEWALL W/4-12d NAILS. POSITION SO AS TO CENTER PIECES MARKED ④ AND ⑥ ON THE JOINT BETWEEN THE BOTTOM TWO LAYERS OF CONTAINERS ON THE UNITS. SEE SPECIAL NOTE 5 AT LEFT.
- ⑤ HORIZONTAL PIECE, 2" X 6" BY CAR WIDTH IN LENGTH ( CUT TO FIT ) ( 2 REQD ). NAIL TO THE CROSS CAR BRACE, PIECE MARKED ⑥, W/1-12d NAIL EVERY 6". SEE SPECIAL NOTE 3 AT LEFT.
- ⑥ CROSS CAR BRACE, 4" X 4" BY CAR WIDTH IN LENGTH ( CUT TO FIT ) ( 2 REQD ).
- ⑦ CENTER CLEAT, 2" X 4" X 36" ( 2 REQD ). NAIL TO THE CROSS CAR BRACE, PIECE MARKED ⑥, W/7-16d NAILS. SEE SPECIAL NOTE 6 ABOVE.
- ⑧ SPACER CLEAT, 2" X 4" X 14-3/4" FOR 4-LAYER UNITS, 10" FOR 3-LAYER UNITS ( 2 REQD ). NAIL TO THE CAR SIDEWALL W/4-12d NAILS.
- ⑨ HORIZONTAL WALL CLEAT, 2" X 6" X 72" ( 4 REQD ). NAIL TO THE CAR SIDEWALL W/16-12d NAILS.
- ⑩ POCKET CLEAT, 2" X 6" X 12" ( 2 REQD ). NAIL TO THE HORIZONTAL WALL CLEAT, PIECE MARKED ⑨, W/4-16d NAILS.
- ⑪ DIAGONAL BRACE, 2" X 4" X 50-1/4" ( 4 REQD ). SEE THE DETAIL AT LEFT FOR BEVEL CUTS REQUIRED. TCENAIL TO THE CROSS CAR BRACE, PIECE MARKED ⑥, AND TO THE HORIZONTAL WALL CLEAT, PIECE MARKED ⑨, W/2-16d NAILS AT EACH END.
- ⑫ BACK-UP CLEAT, 2" X 6" X 24" ( 4 REQD ). NAIL TO THE HORIZONTAL WALL CLEAT, PIECE MARKED ⑨, W/8-16d NAILS.
- ⑬ HOLD-DOWN CLEAT, 2" X 4" X 18" ( 2 REQD ). NAIL TO THE CAR SIDEWALL W/5-12d NAILS.

**SPECIAL NOTES:**

1. THE TYPE "B" K-BRACE SHOWN IS ADEQUATE FOR RETAINING A PARTIAL TIER OF NOT MORE THAN 14,000 POUNDS. THIS WILL BE NOT MORE THAN EIGHT (8) 3-LAYER UNITS OR SIX (6) 4-LAYER UNITS. IF IT IS NECESSARY TO BLOCK A HEAVIER LOAD, REFER TO THE DETAILS ON PAGES 110 AND 111 FOR SELECTION OF THE APPLICABLY SIZED K-BRACE TO USE AND THE DESIGN SPECIFICATIONS FOR THE BRACE. IF THE PARTIAL TIER TO BE BRACED WEIGHS 8,000 POUNDS OR LESS, THE TYPE "A" K-BRACE DEPICTED ON PAGE 108 MAY BE USED.
2. **CAUTION:** SOME CARS ARE NOT SUITED FOR THE APPLICATION OF "PARTIAL-LAYER BRACING" BECAUSE THE LENGTH OF THE PARTIAL TIER TO BE SHIPPED AND/OR THE SIZE OR CONFIGURATION OF THE CAR DOORS WILL NOT PERMIT PROPER INSTALLATION OF THE SPECIFIED K-BRACE DUNNAGE. PIECES MARKED ①, ②, ③, ④, ⑤, ⑥, ⑦, ⑧, ⑨, ⑩, AND ⑪ MUST BE SUPPORTED AT THE SIDES OF A CAR BY A CAR SIDEWALL. IT IS ALRIGHT FOR THE ENDS OF THE DIAGONAL BRACES MARKED ⑦ TO BEAR IN FRONT OF A DOOR OPENING, HOWEVER, THE ADJACENT PIECE MARKED ⑤ MUST BE DOUBLED AND EXTENDED ACROSS AND FAR ENOUGH PAST THE DOOR OPENING (REF 54") TO PROVIDE FOR THE SPECIFIED NAILING OF EACH PIECE. LAMINATE THE SECOND PIECE OF THE DOUBLED PIECE MARKED ⑤ TO THE FIRST W/16-16d NAILS. CLINCH THOSE MARKED NAILS WHICH PROTRUDE THRU THE HORIZONTAL WALL CLEAT WITHIN THE DOOR OPENING. NOTE THAT THE DIAGONAL BRACE WILL BE 49-1/8" LONG IN LIEU OF 50-1/4" WHEN PIECE MARKED ⑤ IS DOUBLED.
3. THE CENTER CLEAT, SHOWN AS PIECE MARKED ④, WILL BE 28" LONG FOR AN 8'-6" WIDE CAR, 36" LONG FOR A 9'-2", AND 38" LONG FOR A 9'-4" WIDE CAR. ADJUST THE LENGTH PROPORTIONATELY FOR CARS OF OTHER WIDTHS.
4. REFER TO PAGE 108 FOR A TYPICAL INSTALLATION OF A K-BRACE.

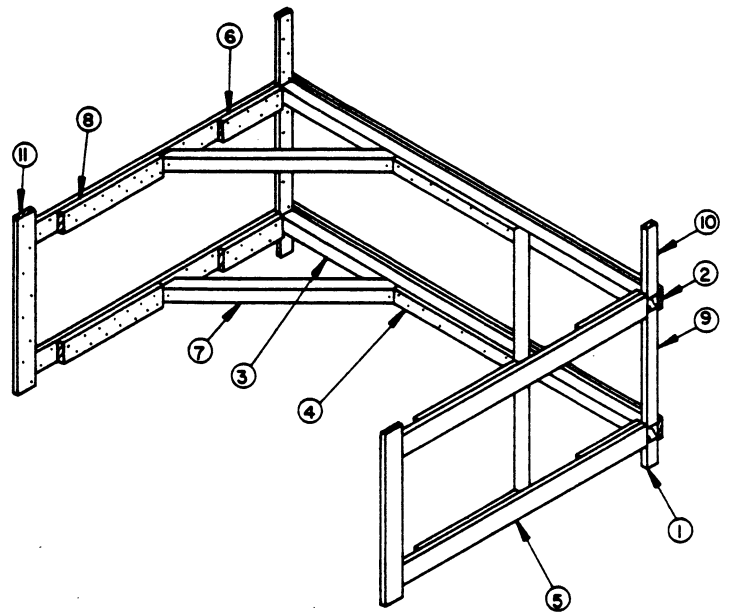

**ISOMETRIC VIEW**

**KEY NUMBERS**

- ① SUPPORT CLEAT, 2" X 4" X 7" (2 REQD). NAIL TO THE CAR SIDEWALL W/2-12d NAILS. POSITION SO AS TO CENTER PIECES MARKED ② AND ⑩ ON THE JOINT BETWEEN THE BOTTOM TWO LAYERS OF CONTAINERS ON THE UNITS. SEE SPECIAL NOTE 2 AT LEFT.
- ② LOAD BEARING PIECE, 2" X 6" BY CAR WIDTH (CUT TO FIT) (2 REQD). NAIL TO THE CROSS CAR BRACE, PIECE MARKED ③, W/1-12d NAIL EVERY 6". SEE GENERAL NOTE "M" ON PAGE 2.
- ③ CROSS CAR BRACE, 4" X 4" BY CAR WIDTH (CUT TO FIT) (2 REQD).
- ④ CENTER CLEAT, 2" X 4" X 36" (2 REQD). NAIL TO THE CROSS CAR BRACE, PIECE MARKED ③, W/7-16d NAILS. SEE SPECIAL NOTE 3 AT LEFT.
- ⑤ HORIZONTAL WALL CLEAT, 2" X 6" X 72" (4 REQD). NAIL TO THE CAR SIDEWALL W/16-12d NAILS.
- ⑥ POCKET CLEAT, 2" X 6" X 18" (4 REQD). NAIL TO THE HORIZONTAL WALL CLEAT, PIECE MARKED ⑤, W/7-16d NAILS.
- ⑦ DIAGONAL BRACE, 4" X 4" X 50-1/4" (4 REQD). SEE THE DETAIL BELOW FOR BEVEL CUTS REQUIRED. TOENAIL TO THE CROSS CAR BRACE, PIECE MARKED ③, AND TO THE HORIZONTAL WALL CLEAT, PIECE MARKED ⑤, W/1-60d NAIL AT EACH END.
- ⑧ BACK-UP CLEAT, 2" X 6" X 30" (4 REQD). NAIL TO THE HORIZONTAL WALL CLEAT, PIECE MARKED ⑤, W/14-16d NAILS.
- ⑨ SPACER CLEAT, 2" X 4" X 14-3/4" FOR 4-LAYER UNITS, 10" FOR 3-LAYER UNITS (2 REQD). NAIL TO THE CAR SIDEWALL W/4-12d NAILS.
- ⑩ HOLD-DOWN CLEAT, 2" X 4" X 18" (2 REQD). NAIL TO THE CAR SIDEWALL W/5-12d NAILS.
- ⑪ VERTICAL BACK-UP CLEAT, 2" X 6" BY UNIT HEIGHT (2 REQD). NAIL TO THE CAR SIDEWALL W/8-12d NAILS.

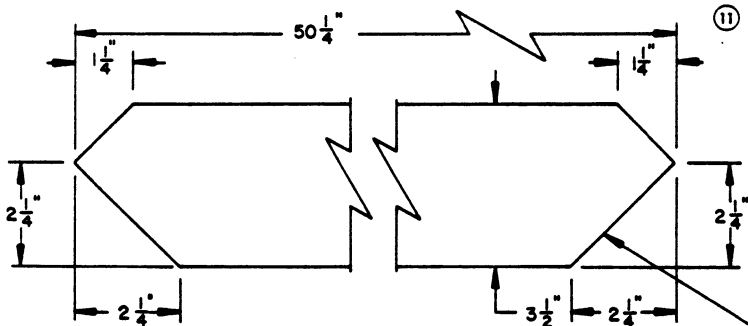

**DIAGONAL BRACE**

SEE SPECIAL NOTE 2 ABOVE.

THIS BEARING SURFACE MUST BE POSITIONED SO AS TO BE IN CONTACT WITH A CROSS CAR BRACE, PIECE MARKED ③, OR A HORIZONTAL WALL CLEAT, PIECE MARKED ⑤.

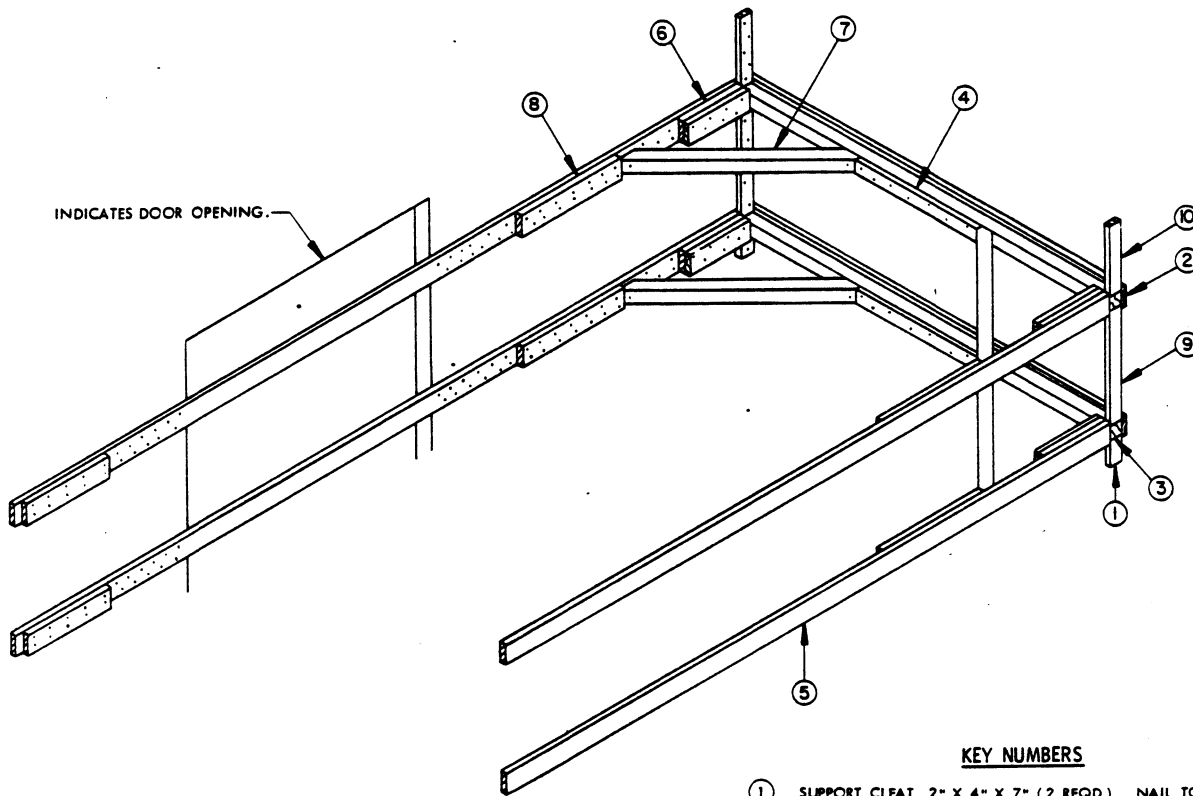

ISOMETRIC VIEW

SPECIAL NOTES:

1. THE TYPE "C" K-BRACE SHOWN IS ADEQUATE FOR RETAINING A PARTIAL TIER OF NOT MORE THAN 20,000 POUNDS. THIS WILL BE NOT MORE THAN TWELVE (12) 3-LAYER UNITS OR NINE (9) 4-LAYER UNITS. IF IT IS NECESSARY TO BLOCK A HEAVIER LOAD, REFER TO THE DETAIL ON PAGE 111 FOR THE APPLICABLY SIZED K-BRACE TO USE AND THE DESIGN SPECIFICATIONS FOR THE BRACE. IF THE PARTIAL TIER TO BE BRACED WEIGHS BETWEEN 8,000 POUNDS AND 14,000 POUNDS, THE TYPE "B" K-BRACE DEPICTED ON PAGE 109 MAY BE USED. IF THE PARTIAL TIER TO BE BRACED WEIGHS 8,000 POUNDS OR LESS, THE TYPE "A" K-BRACE DEPICTED ON PAGE 108 WILL BE ADEQUATE.
2. CAUTION: SOME CARS ARE NOT SUITED FOR THE APPLICATION OF "PARTIAL-LAYER BRACING" BECAUSE THE LENGTH OF THE PARTIAL TIER WILL NOT PERMIT PROPER INSTALLATION OF THE SPECIFIED K-BRACE DUNNAGE. PIECES MARKED ①, ②, ③, ⑥, ⑨, AND ⑩ MUST BE SUPPORTED AT THE SIDES OF A CAR BY A CAR SIDEWALL. IT IS ALRIGHT FOR THE ENDS OF THE DIAGONAL BRACES MARKED ⑦ TO BEAR IN FRONT OF A DOOR OPENING, HOWEVER, THE ADJACENT PIECE MARKED ⑤ MUST BE DOUBLED. LAMINATE THE SECOND PIECE TO THE FIRST W/40-16d NAILS. CLINCH THOSE NAILS WHICH PROTRUDE THRU THE HORIZONTAL WALL CLEAT WITHIN THE DOOR OPENING. NOTE THAT THE DIAGONAL BRACE WILL BE 49-1/8" LONG IN LIEU OF 50-1/4" WHEN PIECE MARKED ⑤ IS DOUBLED.

(CONTINUED AT RIGHT)

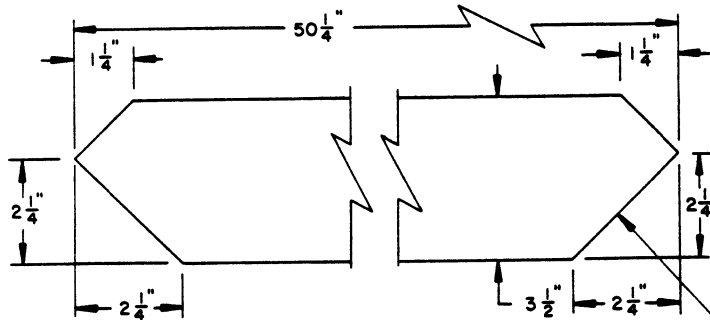

DIAGONAL BRACE

SEE SPECIAL NOTE 2 ABOVE.

KEY NUMBERS

- ① SUPPORT CLEAT, 2" X 4" X 7" (2 REQD.). NAIL TO THE CAR SIDEWALL W/2-12d NAILS. POSITION SO AS TO CENTER PIECES MARKED ② AND ③ ON THE JOINT BETWEEN THE BOTTOM TWO LAYERS OF CONTAINERS ON THE UNITS. SEE SPECIAL NOTE 2 AT LEFT.
- ② LOAD BEARING PIECE, 2" X 6" BY CAR WIDTH (CUT TO FIT) (2 REQD.). NAIL TO THE CROSS CAR BRACE, PIECE MARKED ③, W/1-12d NAIL EVERY 6". SEE GENERAL NOTE "M" ON PAGE 2.
- ③ CROSS CAR BRACE, 4" X 4" BY CAR WIDTH (CUT TO FIT) (2 REQD.).
- ④ CENTER CLEAT, 2" X 4" X 36" (2 REQD.). NAIL TO THE CROSS CAR BRACE, PIECE MARKED ③, W/7-16d NAILS. SEE SPECIAL NOTE 3 BELOW.
- ⑤ HORIZONTAL WALL CLEAT, 2" X 6" BY CUT TO FIT (4 REQD.). A CLEAT WILL BE OF A LENGTH AS NECESSARY TO EXTEND ACROSS AND FAR ENOUGH PAST THE DOOR OPENINGS TO CONTACT PIECE MARKED ③ OF THE K-BRACE IN THE OPPOSITE END OF THE CAR. NAIL TO THE CAR SIDEWALL W/40-12d NAILS.
- ⑥ POCKET CLEAT, 2" X 6" X 18" (DOUBLED) (4 REQD.). NAIL THE FIRST PIECE TO THE HORIZONTAL WALL CLEAT, PIECE MARKED ⑤, W/7-16d NAILS. NAIL THE SECOND PIECE TO THE FIRST IN A LIKE MANNER.
- ⑦ DIAGONAL BRACE, 4" X 4" X 50-1/4" (4 REQD.). SEE THE DETAIL BELOW FOR BEVEL CUTS REQUIRED. TOENAIL TO THE CROSS CAR BRACE, PIECE MARKED ③, AND TO THE HORIZONTAL WALL CLEAT, PIECE MARKED ⑤, W/1-60d NAIL AT EACH END.
- ⑧ BACK-UP CLEAT, 2" X 6" X 30" (4 REQD.). NAIL TO THE HORIZONTAL WALL CLEAT, PIECE MARKED ⑤, W/14-16d NAILS.
- ⑨ SPACER CLEAT, 2" X 4" X 14-3/4" FOR 4-LAYER UNITS, 10" FOR 3-LAYER UNITS (2 REQD.). NAIL TO THE CAR SIDEWALL W/4-12d NAILS.
- ⑩ HOLD-DOWN CLEAT, 2" X 4" X 18" (2 REQD.). NAIL TO THE CAR SIDEWALL W/5-12d NAILS.

(SPECIAL NOTES CONTINUED)

3. THE CENTER CLEAT, SHOWN AS PIECE MARKED ④, WILL BE 28" LONG FOR AN 8'-6" WIDE CAR, 36" LONG FOR A 9'-2", AND 38" LONG FOR A 9'-4" WIDE CAR. ADJUST THE LENGTH PROPORTIONATELY FOR CARS OF OTHER WIDTHS.
4. CAUTION: A TYPE "C" K-BRACE MUST BE USED IN BOTH ENDS OF THE CAR; THE BRACE IS NOT DESIGNED FOR USE IN ONLY ONE END. NOTE THAT EXCEPT FOR PIECES MARKED ⑤, THE QUANTITIES SPECIFIED ARE APPLICABLE ONLY FOR THE BRACE IN ONE END.

THIS BEARING SURFACE MUST BE POSITIONED SO AS TO BE IN CONTACT WITH A CROSS CAR BRACE, PIECE MARKED ③, OR A HORIZONTAL WALL CLEAT, PIECE MARKED ⑤.

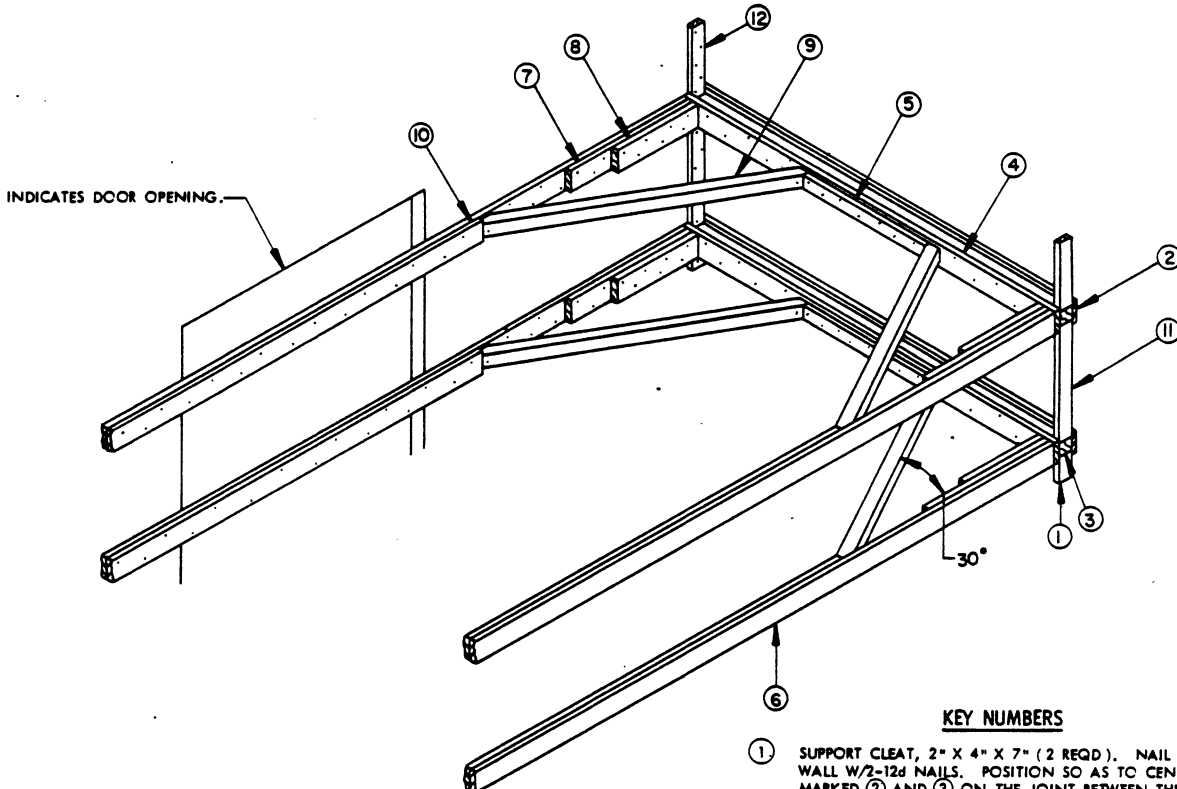

ISOMETRIC VIEW

**SPECIAL NOTES:**

1. THE TYPE "D" K-BRACE SHOWN IS ADEQUATE FOR RETAINING A PARTIAL TIER OF NOT MORE THAN 25,000 POUNDS. THIS WILL BE NOT MORE THAN FIFTEEN (15) 3-LAYER UNITS OR ELEVEN (11) 4-LAYER UNITS. IF THE PARTIAL TIER TO BE BRACED WEIGHS BETWEEN 14,000 POUNDS AND 20,000 POUNDS, THE TYPE "C" K-BRACE DEPICTED ON PAGE 110 MAY BE USED. FOR A PARTIAL TIER OF 8,000 POUNDS TO 14,000 POUNDS, THE TYPE "B" K-BRACE DEPICTED ON PAGE 107 MAY BE USED. IF THE PARTIAL TIER TO BE BRACED WEIGHS 8,000 POUNDS OR LESS, THE TYPE "A" K-BRACE DEPICTED ON PAGE 108 WILL BE ADEQUATE.
2. **CAUTION:** SOME CARS ARE NOT SUITED FOR THE APPLICATION OF "PARTIAL-LAYER BRACING" BECAUSE THE LENGTH OF THE PARTIAL TIER TO BE SHIPPED AND/OR THE SIZE OR CONFIGURATION OF THE CAR DOORS WILL NOT PERMIT PROPER INSTALLATION OF THE SPECIFIED K-BRACE DUNNAGE. PIECES MARKED ①, ②, ③, ④, ⑦, ⑧, ⑪ AND ⑫ MUST BE SUPPORTED AT THE SIDES OF A CAR BY A CAR SIDEWALL. IT IS ALRIGHT FOR THE ENDS OF THE DIAGONAL BRACES MARKED ⑨ TO BEAR IN FRONT OF A DOOR OPENING, HOWEVER, THE ADJACENT PIECE MARKED ⑥ MUST BE DOUBLED. LAMINATE THE SECOND PIECE TO THE FIRST W/40-16d NAILS. CLINCH THOSE NAILS WHICH PROTRUDE THRU THE HORIZONTAL WALL CLEAT WITHIN THE DOOR OPENING. NOTE THAT THE DIAGONAL BRACE WILL BE 70-1/4" LONG IN LIEU OF 71" LONG WHEN PIECE MARKED ⑥ IS DOUBLED.
3. THE CENTER CLEAT, SHOWN AS PIECE MARKED ⑤, WILL BE 28" LONG FOR AN 8'-6" WIDE CAR, 36" LONG FOR A 9'-2", AND 38" LONG FOR A 9'-4" WIDE CAR. ADJUST THE LENGTH PROPORTIONATELY FOR CARS OF OTHER WIDTHS.
4. **CAUTION:** A TYPE "D" K-BRACE MUST BE USED IN BOTH ENDS OF THE CAR; THE BRACE IS NOT DESIGNED FOR USE IN ONLY ONE END. NOTE THAT EXCEPT FOR PIECES MARKED ⑥ AND ⑩, THE QUANTITIES SPECIFIED ARE APPLICABLE ONLY FOR THE BRACE IN ONE END.

**KEY NUMBERS**

- ① SUPPORT CLEAT, 2" X 4" X 7" (2 REQD). NAIL TO THE CAR SIDEWALL W/7-12d NAILS. POSITION SO AS TO CENTER PIECES MARKED ② AND ③ ON THE JOINT BETWEEN THE BOTTOM TWO LAYERS OF CONTAINERS ON THE UNITS. SEE SPECIAL NOTE 2 AT LEFT.
- ② LOAD BEARING PIECE, 2" X 6" BY CAR WIDTH (CUT TO FIT) (2 REQD). NAIL TO THE CROSS CAR BRACE, PIECE MARKED ③, W/1-12d NAIL EVERY 6". SEE GENERAL NOTE "M" ON PAGE 2.
- ③ CROSS CAR BRACE, 4" X 4" BY CAR WIDTH (CUT TO FIT) (2 REQD).
- ④ HORIZONTAL PIECE, 2" X 6" BY CAR WIDTH (CUT TO FIT) (2 REQD). NAIL TO THE CROSS CAR BRACE, PIECE MARKED ③, W/1-12d NAIL EVERY 6".
- ⑤ CENTER CLEAT, 2" X 4" X 36" (2 REQD). NAIL TO THE HORIZONTAL PIECE, PIECE MARKED ④, W/7-16d NAILS. SEE SPECIAL NOTE 3 AT LEFT.
- ⑥ HORIZONTAL WALL CLEAT, 2" X 6" BY CUT TO FIT (4 REQD). A CLEAT WILL BE OF A LENGTH AS NECESSARY TO EXTEND ACROSS AND FAR ENOUGH PAST THE DOOR OPENING TO CONTACT PIECE MARKED ④ OF THE K-BRACE IN THE OPPOSITE END OF THE CAR. NAIL TO THE CAR SIDEWALL W/40-12d NAILS.
- ⑦ POCKET CLEAT, 2" X 6" X 36" (4 REQD). NAIL TO THE HORIZONTAL WALL CLEAT, PIECE MARKED ⑥, W/10-16d NAILS.
- ⑧ POCKET CLEAT, 2" X 6" X 24" (4 REQD). NAIL TO THE POCKET CLEAT, PIECE MARKED ⑦, W/7-16d NAILS.
- ⑨ DIAGONAL BRACE, 4" X 4" X 71" (4 REQD). SEE THE DETAIL BELOW FOR BEVEL CUTS REQUIRED. TOENAIL TO THE HORIZONTAL PIECE, PIECE MARKED ④, AND TO THE HORIZONTAL WALL CLEAT, PIECE MARKED ⑥, W/1-60d NAIL AT EACH END.
- ⑩ BACK-UP CLEAT, 2" X 6" BY CUT TO FIT (4 REQD). A CLEAT WILL BE OF A LENGTH AS NECESSARY TO EXTEND TO CONTACT THE DIAGONAL BRACE, PIECE MARKED ⑨, IN THE OPPOSITE END OF THE CAR. NAIL TO THE HORIZONTAL WALL CLEAT, PIECE MARKED ⑥, W/18-16d NAILS. CLINCH THOSE NAILS WHICH PROTRUDE THRU THE HORIZONTAL WALL CLEAT WITHIN THE DOOR OPENING, IF APPLICABLE.
- ⑪ SPACER CLEAT, 2" X 4" X 14-3/4" FOR 4-LAYER UNITS, 10" FOR 3-LAYER UNITS (2 REQD). NAIL TO THE CAR SIDEWALL W/4-12d NAILS.
- ⑫ HOLD-DOWN CLEAT, 2" X 4" X 18" (2 REQD). NAIL TO THE CAR SIDEWALL W/5-12d NAILS.

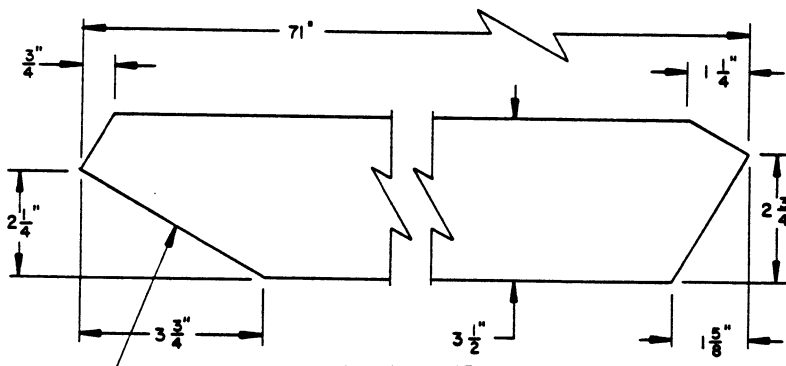

**DIAGONAL BRACE**  
SEE SPECIAL NOTE 2 ABOVE.

THIS BEARING SURFACE MUST BE POSITIONED SO AS TO BE IN CONTACT WITH A HORIZONTAL WALL CLEAT, PIECE MARKED ⑥.

**TYPE "D" K-BRACE**

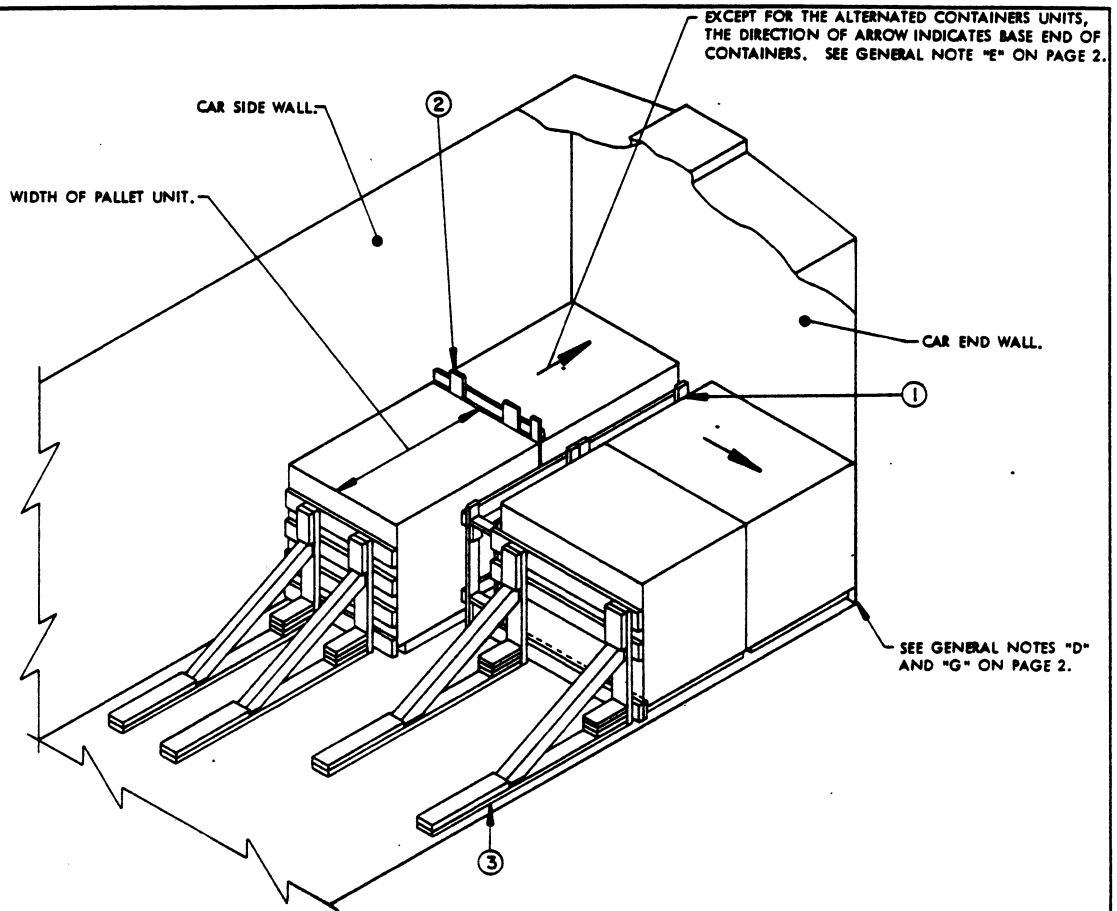

**ISOMETRIC VIEW**

**SPECIAL NOTES:**

1. A 9'-2" WIDE WOOD-LINED CONVENTIONAL TYPE BOX CAR HAVING A WOOD OR NAILABLE METAL FLOOR IS SHOWN. CARS OF OTHER WIDTHS AND CARS HAVING METAL LININGS CAN BE USED.
2. THE PALLET UNIT SHOWN IS THE ROUTED DUNNAGE METHOD UNIT (BASIC HEIGHT). THE DEPICTED PROCEDURES ARE ALSO APPLICABLE FOR THE OTHER UNITS COVERED BY THIS DOCUMENT.
3. THE LOAD SHOWN DEPICTING THE KNEE BRACE METHOD OF PARTIAL-LAYER BRACING IS TYPICAL. THE QUANTITY MAY BE ADJUSTED TO SUIT, PROVIDED THE LIMITATIONS OF THE KNEE BRACE AS SET FORTH IN SPECIAL NOTE 4 ARE NOT EXCEEDED. ALSO, THE LOAD MAY CONSIST OF TWO LENGTHWISE ROWS, OR TWO CROSSWISE ROWS IN LIEU OF ONE OF EACH AS DEPICTED.
4. A KNEE BRACE ASSEMBLY WILL BE USED FOR EACH ROW OF PALLET UNITS. ONE (1) KNEE BRACE ASSEMBLY IS ADEQUATE FOR RETAINING A MAXIMUM LCL LOAD OF NOT MORE THAN 8,500 POUNDS.
5. HOLD-DOWN CLEATS (GATE HOLD DOWN) MUST BE APPLIED TO THE BOTTOM HORIZONTAL PIECE OF A KNEE BRACE ASSEMBLY. THE PROPER MATERIAL SIZE AND PLACEMENT WILL BE AS DEPICTED BY THE CENTER GATE DETAILS FOR ONE ROW SPECIFIED ELSEWHERE. FOR HOLD DOWN PIECES TO BE APPLIED TO THE KNEE BRACE ASSEMBLY WHICH IS USED AGAINST THE LENGTHWISE ROW, REFER TO THE "CENTER GATE A" DETAIL ON PAGE 16 FOR THE ALTERNATED CONTAINERS UNITS, THE "CENTER GATE J" DETAIL ON PAGE 44 FOR THE FLAT DUNNAGE METHOD UNITS, OR THE "CENTER GATE R" DETAIL ON PAGE 72 FOR THE ROUTED DUNNAGE METHOD UNITS. FOR HOLD DOWN PIECES TO BE APPLIED TO THE KNEE BRACE ASSEMBLY WHICH IS USED AGAINST THE CROSSWISE ROW, REFER TO THE "CENTER GATE B" DETAIL ON PAGE 17 FOR THE ALTERNATED CONTAINERS UNITS, THE "CENTER GATE K" DETAIL ON PAGE 45 FOR THE FLAT DUNNAGE METHOD UNITS, OR THE "CENTER GATE S" DETAIL ON PAGE 73 FOR THE ROUTED DUNNAGE METHOD UNITS.

**KEY NUMBERS**

- ① CRIB FILL (2 REQD). SEE THE APPLICABLE CRIB FILL DETAIL ON PAGE 16, 30, 44, 58, 72, OR 86. SEE GENERAL NOTE "M" ON PAGE 2.
- ② SEPARATOR GATE (1 REQD). SEE THE APPLICABLE SEPARATOR GATE DETAIL ON PAGE 17, 31, 45, 59, 73, OR 87. POSITION WITH THE HORIZONTAL PIECES AGAINST THE ALREADY-LOADED UNIT.
- ③ KNEE BRACE ASSEMBLY (2 REQD). SEE THE DETAIL ON PAGE 113 FOR CONSTRUCTION SPECIFICATIONS AND NAILING REQUIREMENTS.



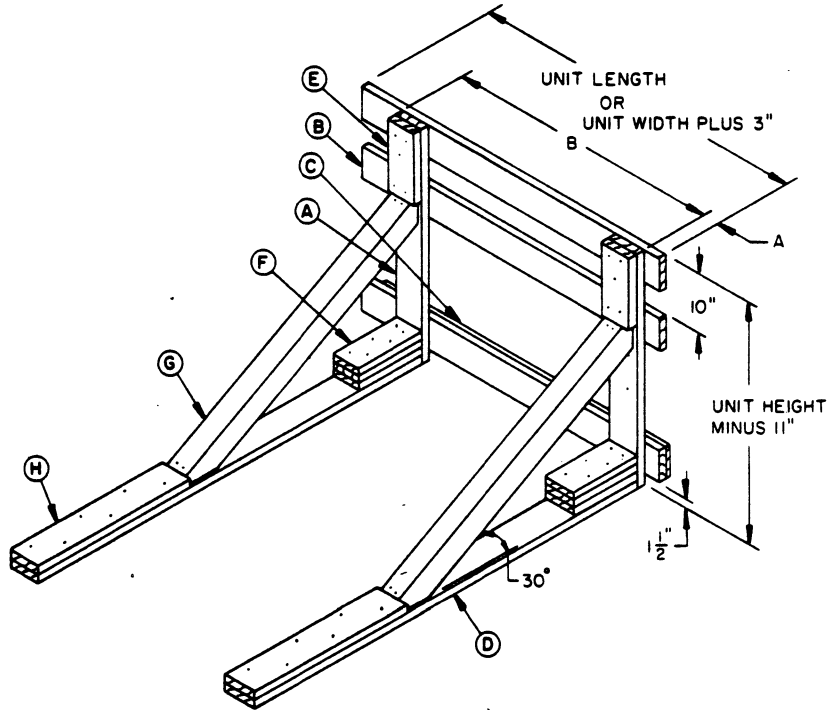

**KNEE BRACE ASSEMBLY**

VERTICAL PIECE PLACEMENT FOR CROSSWISE UNITS		
UNIT	DIM A	DIM B
ALTERNATED CONTAINERS	7-1/2"	47-1/2"
FLAT DUNNAGE	4"	52"
ROUTED DUNNAGE	4"	52"

VERTICAL PIECE PLACEMENT FOR LENGTHWISE UNITS		
UNIT	DIM A	DIM B
ALTERNATED CONTAINERS	7-1/2"	32-1/2"
FLAT DUNNAGE	8-1/2"	34-1/2"
ROUTED DUNNAGE	7-3/4"	34-1/4"

**KEY LETTERS**

- (A) VERTICAL PIECE, 2" X 6" BY UNIT HEIGHT MINUS 11" (2 REQD). SEE THE CHARTS AT LEFT FOR PLACEMENT DIMENSIONS.
- (B) HORIZONTAL PIECE, 2" X 6" BY PALLET UNIT LENGTH, OR PALLET UNIT WIDTH PLUS 3", AS APPLICABLE. NAIL TO THE VERTICAL PIECES W/3-10d NAILS AT EACH JOINT. SEE GENERAL NOTE "M" ON PAGE 2.
- (C) HORIZONTAL PIECE, 1" X 6" BY PALLET UNIT WIDTH OR LENGTH (1 REQD FOR ROUTED DUNNAGE METHOD UNITS ONLY). NAIL TO THE BOTTOM HORIZONTAL PIECE MARKED (E) W/1-6d NAIL EVERY 12".
- (D) FLOOR CLEAT, 2" X 6" BY LENGTH TO SUIT (.87 OR 7/8 TIMES LENGTH OF PIECE MARKED (C), PLUS 30") (2 REQD). ALIGN WITH A VERTICAL PIECE AND NAIL TO THE CAR FLOOR W/1-16d NAIL EVERY 8". SEE GENERAL NOTE "Q" ON PAGE 2.
- (E) HOLD-DOWN CLEAT, 2" X 6" X 12" (2 REQD). NAIL TO A VERTICAL PIECE W/5-10d NAILS.
- (F) POCKET CLEAT, 2" X 6" X 12" (TRIPLED) (2 REQD). NAIL THE FIRST PIECE TO THE FLOOR CLEAT, PIECE MARKED (D), W/4-16d NAILS. NAIL THE SECOND AND THIRD PIECES IN A LIKE MANNER AND TOENAIL THE THIRD PIECE TO THE VERTICAL PIECE, PIECE MARKED (A), W/2-16d NAILS.
- (G) BRACE, 4" X 4" BY CUT TO FIT (KNEE BRACE ASSEMBLY HEIGHT MINUS 13-1/2", TIMES 2) (2 REQD). SEE THE DETAIL AT LEFT FOR BEVEL CUTS REQUIRED. TOENAIL TO THE VERTICAL PIECE AND TO THE FLOOR CLEAT, PIECES MARKED (A) AND (D), W/2-16d NAILS AT EACH JOINT.
- (H) BACK UP CLEAT, 2" X 6" X 30" (2 REQD). NAIL TO THE FLOOR CLEAT, PIECE MARKED (D), W/6-40d NAILS.
- (J) HOLD-DOWN CLEAT (NOT SHOWN). SEE SPECIAL NOTE 5 ON PAGE 112.

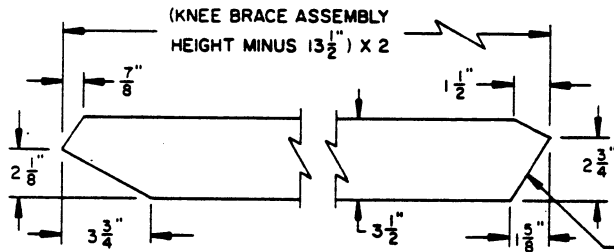

**BRACE**  
4" X 4" MATERIAL

**TYPICAL LCL LOAD USING KNEE BRACE METHOD OF PARTIAL-LAYER BRACING**

CENTER GATE AA						
DIM	3-HIGH UNIT			4-HIGH UNIT		
	ALT	FLAT	ROUTED	ALT	FLAT	ROUTED
G	32"	36"	34"	43"	46"	44"
H	6'-2"	6'-2"	6'-2"	6'-2"	6'-2"	6'-2"
J	17"	13-1/2"	13-1/2"	17"	13-1/2"	13-1/2"
K	57"	61-1/2"	61-1/2"	57"	61-1/2"	61-1/2"
L	9-1/2"	9-3/4"	18-3/4"	9-1/2"	9-3/4"	19"
M	18-1/4"	20-1/4"	—	28"	30-3/4"	29-1/2"
N	28"	30-3/4"	29-1/2"	38"	41-1/4"	40"

\* BASE END OF CONTAINER.

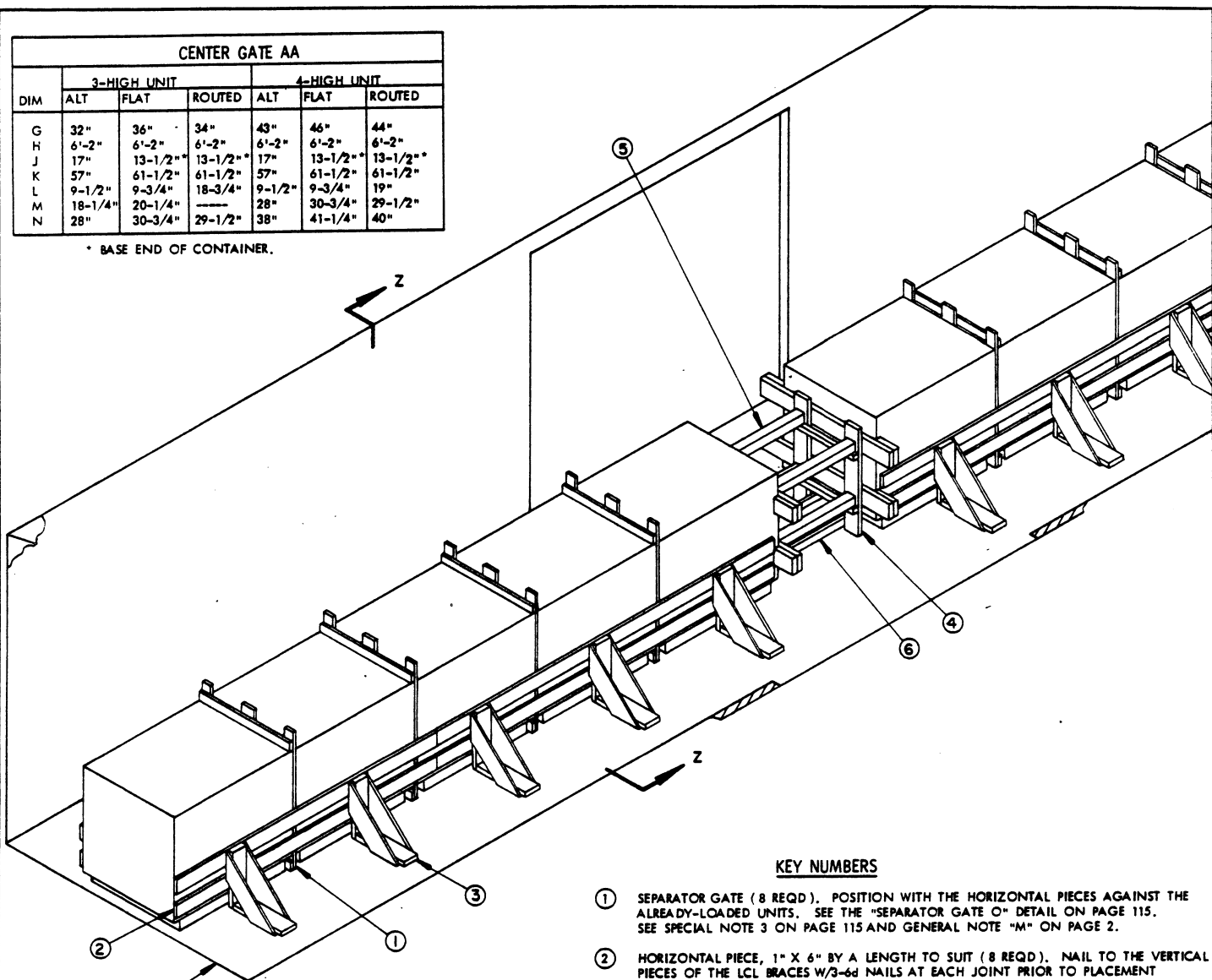

SEE GENERAL NOTE "G" ON PAGE 2.

ISOMETRIC VIEW

**KEY NUMBERS**

- ① SEPARATOR GATE (8 REQD). POSITION WITH THE HORIZONTAL PIECES AGAINST THE ALREADY-LOADED UNITS. SEE THE "SEPARATOR GATE O" DETAIL ON PAGE 115. SEE SPECIAL NOTE 3 ON PAGE 115 AND GENERAL NOTE "M" ON PAGE 2.
- ② HORIZONTAL PIECE, 1" X 6" BY A LENGTH TO SUIT (8 REQD). NAIL TO THE VERTICAL PIECES OF THE LCL BRACES W/3-6d NAILS AT EACH JOINT PRIOR TO PLACEMENT AGAINST THE LADING. SEE THE "LCL BRACE" DETAIL ON PAGE 116 FOR HEIGHT LOCATION GUIDANCE.
- ③ LCL BRACE (20 REQD). SEE THE DETAIL ON PAGE 116 AND SPECIAL NOTE 4 ON PAGE 115. NAIL TO THE CAR FLOOR W/7-16d NAILS. SEE GENERAL NOTE "Q" ON PAGE 2.
- ④ CENTER GATE (2 REQD). SEE THE "CENTER GATE Z" OR THE "CENTER GATE AA" DETAIL ON PAGE 115 FOR LENGTHWISE OR CROSSWISE UNITS, RESPECTIVELY.
- ⑤ STRUT, 4" X 4" BY CUT TO FIT (4 REQD FOR LENGTHWISE, 6 REQD FOR MOST CROSSWISE). TOENAIL TO PIECES MARKED ④ W/2-16d NAILS AT EACH END. SEE GENERAL NOTES "S" AND "T" ON PAGE 2.
- ⑥ GATE HOLD DOWN, 2" X 3" BY LENGTH OF CENTER VOID PLUS 24" (2 REQD). NAIL TO THE VERTICAL PIECES OF THE CENTER GATES W/2-10d NAILS AT EACH JOINT. SEE THE "CENTER GATE Z" DETAIL ON PAGE 115 FOR LOCATION GUIDANCE. NOTE THAT FOR THE CROSSWISE UNITS, THE GATE HOLD DOWN PIECES WILL BE POSITIONED ON THE OUTWARD SIDE OF THE CENTER GATE VERTICAL PIECES. SEE SPECIAL NOTE 6 ON PAGE 115.

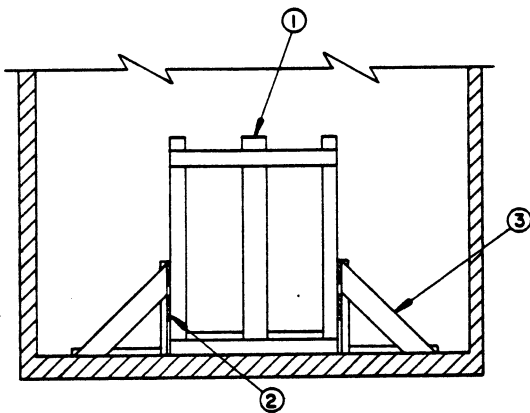

SECTION Z-Z

CENTER GATE Z						
DIM	3-HIGH UNIT			4-HIGH UNIT		
	ALT	FLAT	ROUTED	ALT	FLAT	ROUTED
A	33"	34"	34"	42"	45"	44"
B	59-1/4"	61-1/2"	60-1/2"	59-1/4"	61-1/2"	60-1/2"
C	16-3/8"	17-1/2"	17"	16-3/8"	17-1/2"	17"
D	43"	44"	44"	43"	44"	44"
E	18-1/2"	19-1/2"	19"	18-1/2"	19-1/2"	19"
F	28-1/4"	30"	29-1/2"	38"	40-1/2"	40"

VERTICAL PIECE, 1" X 4" BY UNIT HEIGHT PLUS 6" (2 REQD.).

VERTICAL PIECE, 1" X 6" BY UNIT HEIGHT PLUS 6" (1 REQD.).

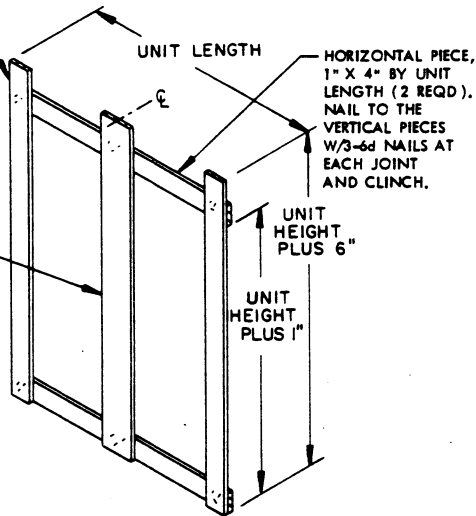

**SEPARATOR GATE 0**

GATE RETAINER, 2" X 6" X 9" (4 REQD.). NAIL TO A HORIZONTAL PIECE W/3-10d NAILS.

VERTICAL PIECE, 2" X 6" BY A LENGTH TO SUIT (2 REQD.).

HEIGHT OF STRUT LEDGER TO BE 4-1/2" LESS THAN HEIGHT OF ADJACENT HORIZONTAL PIECE.

STRUT LEDGER, 2" X 2" X 26-1/2" (2 REQD.). NAIL TO THE VERTICAL PIECES W/2-10d NAILS AT EACH END.

HORIZONTAL PIECE 2" X 6" BY A LENGTH TO SUIT (2 REQD.). NAIL TO THE VERTICAL PIECES W/3-10d NAILS AT EACH END.

GATE RETAINER, 2" X 6" X 9" (4 REQD.). NAIL TO A HORIZONTAL PIECE W/3-10d NAILS.

HEIGHT OF STRUT LEDGER TO BE 4-1/2" LESS THAN HEIGHT OF ADJACENT HORIZONTAL PIECE.

VERTICAL PIECE, 2" X 6" BY A LENGTH TO SUIT (2 REQD.).

STRUT LEDGER, 2" X 2" BY A LENGTH TO SUIT (AS REQD.). NAIL TO THE VERTICAL PIECES W/2-10d NAILS AT EACH END.

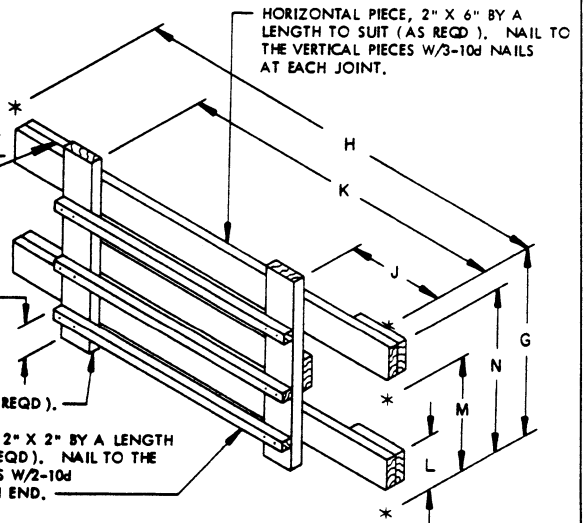

**CENTER GATE Z**

THIS GATE IS FOR USE WITH LENGTHWISE UNITS. REFER TO THE "CENTER GATE Z" CHART ON PAGE 114 FOR FIGURES REPRESENTED BY LETTERS ON THE ABOVE DETAIL.

**CENTER GATE AA**

THIS GATE IS FOR USE WITH CROSSWISE UNITS. REFER TO THE "CENTER GATE AA" CHART AT TOP OF PAGE 114 FOR FIGURES REPRESENTED BY LETTERS ON THE DETAIL ABOVE.

**BILL OF MATERIAL (TYPICAL)**

LUMBER	LINEAR FEET	BOARD FEET
1" X 4"	56	19
1" X 6"	334	167
2" X 2"	9	3
2" X 3"	12	6
2" X 6"	121	121
4" X 4"	14	19
NAILS	NO. REQD	POUNDS
6d (2")	264	1-3/4
8d (2-1/2")	240	2-1/2
10d (3")	72	1-1/4
16d (3-1/2")	156	3-1/2

**LOAD AS SHOWN (TYPICAL)**

ITEM	QUANTITY	WEIGHT (APPROX)
PALLET UNIT	10	21,220 LBS
DUNNAGE		679 LBS
<b>TOTAL WEIGHT</b>		<b>21,899 LBS</b>

**SPECIAL NOTES:**

1. A 50'-6" LONG BY 9'-2" WIDE CONVENTIONAL TYPE BOX CAR IS SHOWN. CARS OF OTHER WIDTHS CAN BE USED, AND SHORTER BUT NOT LONGER CARS WILL BE USED.
2. THE PALLET UNIT SHOWN IN THE TYPICAL 1-WIDE LOAD IS THE ROUTED DUNNAGE METHOD UNIT (BASIC HEIGHT). THE DEPICTED PROCEDURES ARE ALSO APPLICABLE FOR THE OTHER UNITS COVERED BY THIS DOCUMENT.
3. A 1-WIDE LENGTHWISE LOAD IS SHOWN AS TYPICAL. A CHART IS GIVEN TO SPECIFY THE PROPER DIMENSIONS FOR THE LENGTH AND POSITIONING OF PIECES FOR THE CENTER GATES. THE DEPICTED PROCEDURES ARE ALSO APPLICABLE FOR 1-WIDE CROSSWISE LOADS FOR WHICH THERE IS ALSO A CHART WHICH SPECIFIES LENGTHS AND POSITIONING OF PIECES FOR THE CENTER GATES. NOTE THAT THE SEPARATOR GATES, PIECES MARKED ①, ARE NOT REQUIRED, AND THE QUANTITY OF LCL BRACES, PIECES MARKED ③, IS NOT CORRECT FOR CROSSWISE LOADS.
4. ONE (1) LCL BRACE WILL BE USED AT EACH SIDE OF EACH PALLET UNIT. FOR CROSSWISE PALLET UNITS, THE BRACES WILL BE CENTERED ON THE LENGTH OF THE UNIT. FOR THE LENGTHWISE UNITS, THE BRACES WILL BE LOCATED NEAR THE CENTER OF THE UNIT WIDTH, WITH SLIGHT ADJUSTMENTS AS NECESSARY TO ALIGN A BRACE WITH THE INTERMEDIATE DUNNAGE PIECES OF THE ROUTED DUNNAGE METHOD UNIT, OR THE CROSS PIECE OF AN INTERMEDIATE DUNNAGE ASSEMBLY OF THE FLAT DUNNAGE METHOD UNIT.
5. THE BILL OF MATERIAL AND LOAD AS SHOWN ARE BASED ON THE DEPICTED UNIT AND THEREFORE ARE ONLY TYPICAL.
6. IF DESIRED, GATE HOLD DOWN PIECES WITH THE ASSOCIATED FILL PIECES, AS SHOWN ELSEWHERE ON THE APPLICABLE CENTER GATE FOR A SINGLE ROW, MAY BE USED IN LIEU OF PIECES MARKED ⑥.

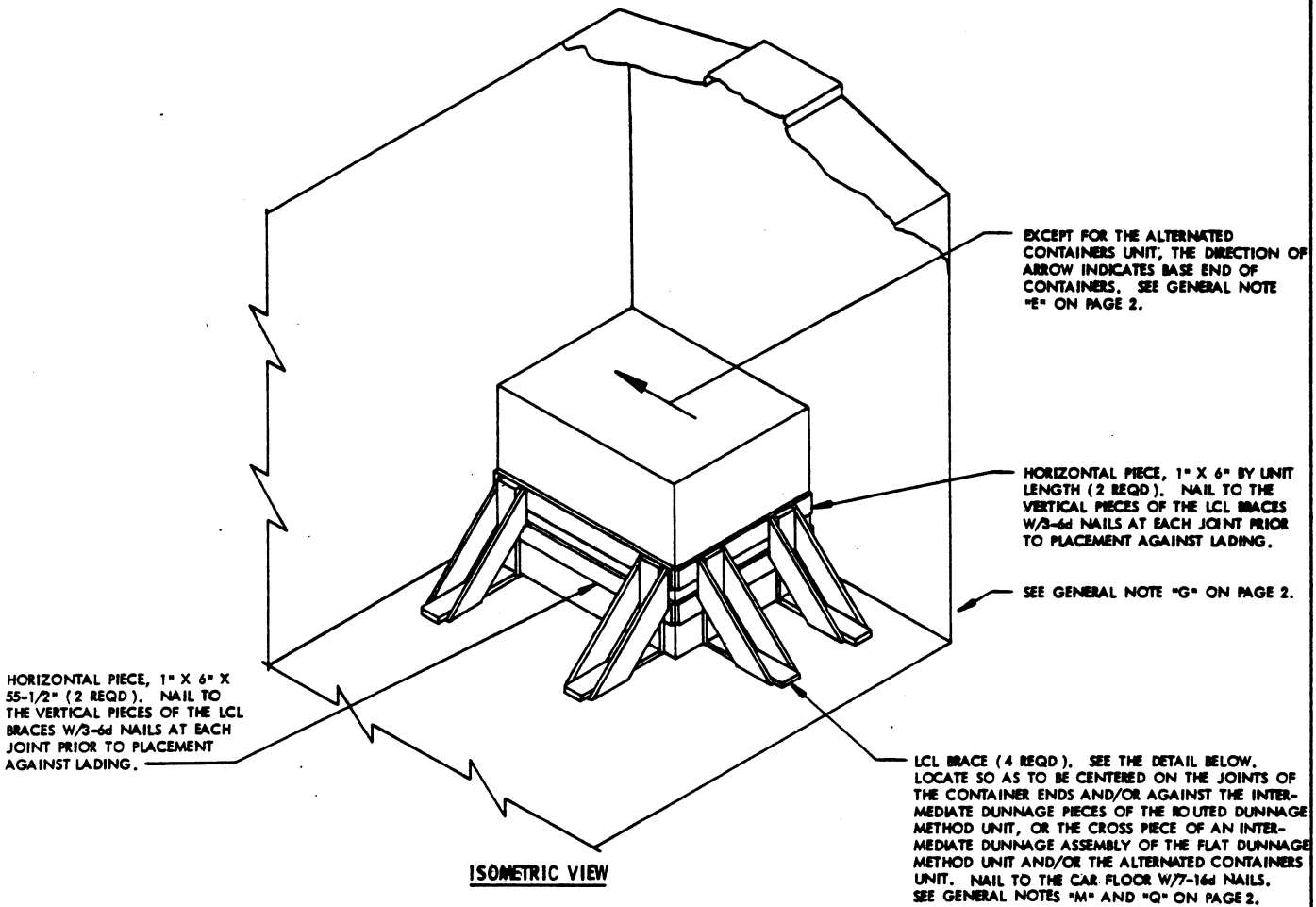

**SPECIAL NOTES:**

1. AN 8'-6" WIDE WOOD-LINED CONVENTIONAL TYPE BOX CAR HAVING A WOOD OR NAILABLE METAL FLOOR IS SHOWN. CARS OF OTHER WIDTHS CAN BE USED. SEE GENERAL NOTES "Q" AND "D" ON PAGE 2.
2. THE PALLET UNIT SHOWN IN THE TYPICAL LCL LOAD IS THE ROUTED DUNNAGE METHOD UNIT (BASIC HEIGHT). THE DEPICTED PROCEDURES ARE ALSO APPLICABLE FOR THE OTHER UNITS COVERED BY THIS DOCUMENT.
3. THE LOAD SHOWN DEPICTING THE LCL BRACE METHOD OF PARTIAL-LAYER BRACING IS TYPICAL. A CROSSWISE UNIT IS SHOWN. HOWEVER, THE PROCEDURES ARE ALSO APPLICABLE FOR LENGTHWISE UNITS AND FOR OTHER QUANTITIES AS LONG AS THE CAPACITY OF THE BRACES IS NOT EXCEEDED. SEE SPECIAL NOTE 4.
4. EACH LCL BRACE AS APPLIED FOR LONGITUDINAL BRACING WILL RETAIN 2,000 POUNDS OF LADING. EACH LCL BRACE AS APPLIED FOR LATERAL BRACING WILL SUPPORT 8,000 POUNDS OF LADING. A MINIMUM OF TWO (2) BRACES MUST BE USED FOR LONGITUDINAL BRACING.

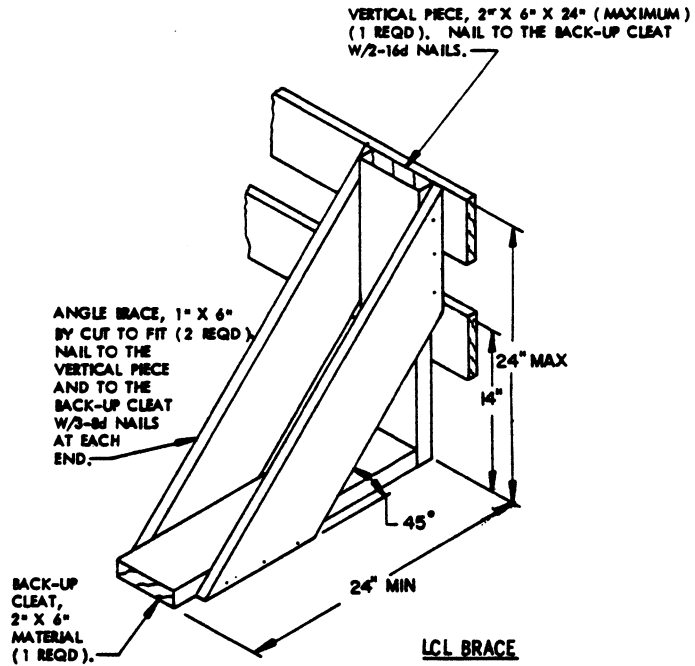

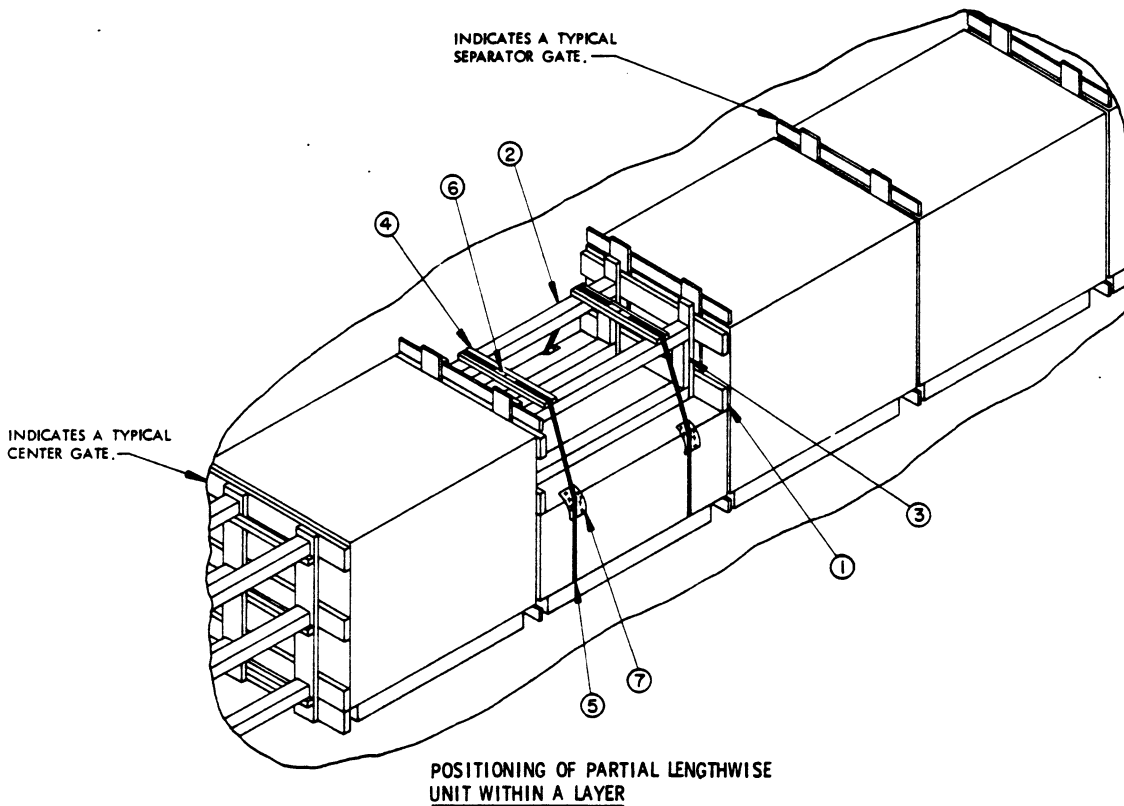

**SPECIAL NOTES:**

1. SHIPMENTS OF PROPELLING CHARGES SHOULD CONSIST OF FULL-HEIGHT AND FULL-LAYER UNITS TO THE MAXIMUM EXTENT POSSIBLE. HOWEVER, THE END OF A LOT, OR THE QUANTITY OF ITEMS NEEDED TO FILL A REQUISITION, MAY NECESSITATE THE SHIPMENT OF ONE OR MORE LESS-THAN-FULL PALLET UNITS WITHIN A LOAD. THE PROCEDURES ON THIS PAGE ARE PRESENTED AS GUIDANCE IN THE SHIPMENT OF A PARTIAL UNIT WITHIN A LENGTHWISE LOAD.
2. THE PALLET UNIT SHOWN IN THE SHIPMENT OF PARTIAL UNITS VIEW IS THE ROUTED DUNNAGE METHOD UNIT ( BASIC HEIGHT ). THE DEPICTED PROCEDURES ARE ALSO APPLICABLE FOR THE OTHER UNITS COVERED BY THIS DOCUMENT.
3. A LESS-THAN-FULL HEIGHT PALLET UNIT OF LENGTHWISE-POSITIONED PROPELLING CHARGES WHICH IS TO BE SHIPPED WITHIN A LAYER OF A LOAD HAS NO LIMITATIONS AS TO THE NUMBER OF LAYERS OF CONTAINERS ON THE PARTIAL UNIT. THE DEPICTED PROCEDURES SHOW THE BRACING OF A 2-LAYER UNIT WITHIN A 4-LAYER LOAD. THE PRINCIPLES CAN BE ADAPTED TO SUIT OTHER SIZE PARTIAL UNITS.
4. A PARTIAL UNIT MUST CONSIST OF FULL LAYERS OF FOUR ( 4 ) CONTAINERS, OR AN APPROVED FILLER ASSEMBLY, AS DETAILED BY DRAWING 19-48-4042A/1-20PM1001, MUST BE INSTALLED IN THE PLACE OF OMITTED CONTAINERS.
5. THE FILLERS AS REFERENCED IN SPECIAL NOTE 4 AND THE DUNNAGE DEPICTED ABOVE FOR THE SHIPMENT OF THE PARTIAL UNIT MAY BE REMOVED WHEN A SHIPMENT REACHES DESTINATION. OR IF DESIRED, THE FILLERS MAY REMAIN WITH THE UNIT DURING STORAGE ( IF APPLICABLE ) FOR POSSIBLE USE IN A FUTURE SHIPMENT.
6. THE "POSITIONING OF PARTIAL LENGTHWISE UNIT WITHIN A LAYER" VIEW ABOVE DEPICTS A PORTION OF A CONVENTIONAL BOX CAR LOAD, HOWEVER, THE PROCEDURES ARE ALSO APPLICABLE FOR LOADS IN CARS EQUIPPED WITH LOAD DIVIDER BULKHEADS.

**KEY NUMBERS**

- ① PARTIAL-UNIT GATE ( 2 REQD ). SEE THE "PARTIAL-UNIT GATE A" DETAIL BELOW. SEE GENERAL NOTE "M" ON PAGE 2 AND SPECIAL NOTE 3 AT LEFT.
- ② STRUT, 4" X 4" X 49-3/8" ( 4 REQD ). TOENAIL TO THE VERTICAL PIECES OF THE PARTIAL-UNIT GATE, PIECE MARKED ①, W/2-16d NAILS AT EACH END.
- ③ STRUT SUPPORT PIECE, 2" X 4" X 12" ( 4 REQD ). NAIL TO A VERTICAL PIECE OF THE PARTIAL-UNIT GATE W/3-10d NAILS.
- ④ STRAPPING BOARD, 2" X 4" X 24-1/2" ( 2 REQD ). NAIL TO THE STRUTS, PIECES MARKED ③, W/3-10d NAILS AT EACH END.
- ⑤ UNITIZING STRAP, 1-1/4" X .031" X .035" BY A LENGTH TO SUIT STEEL STRAPPING ( 2 REQD ). PRE-POSITION THRU THE FORKLIFT OPENINGS OF THE PALLET.
- ⑥ SEAL FOR 1-1/4" STEEL STRAPPING ( 4 REQD, 2 PER JOINT ). SEE GENERAL NOTE "N" ON PAGE 2.
- ⑦ ANTI-CHAFING NEUTRAL BARRIER MATERIAL. POSITION BETWEEN CONTAINERS AND STRAPPING AT POINTS OF CONTACT.

HORIZONTAL PIECE, 2" X 6" BY UNIT LENGTH ( AS REQD ).

VERTICAL PIECE, 2" X 4" BY A LENGTH TO SUIT ( 2 REQD ). NAIL TO THE HORIZONTAL PIECES W/3-10d NAILS AT EACH JOINT.

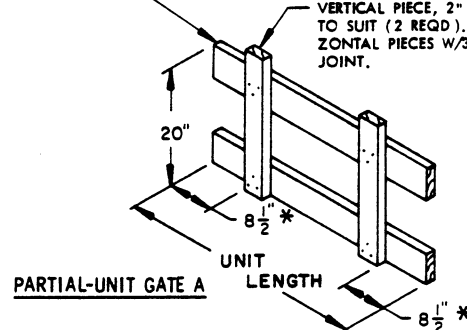

\* THESE DIMENSIONS MUST BE ADJUSTED AS NECESSARY TO ALIGN THE VERTICAL PIECE WITH THE ADJACENT SEPARATOR GATES.

INDICATES A TYPICAL CENTER GATE.

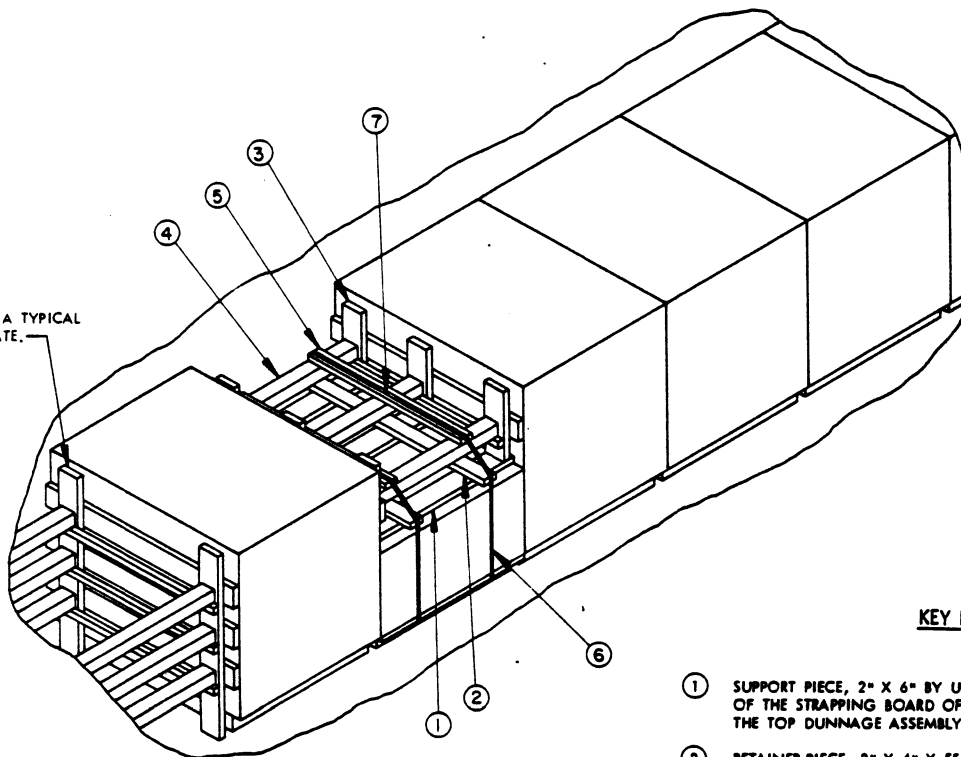

**POSITIONING OF PARTIAL CROSSWISE UNIT IN A LAYER**

**KEY NUMBERS**

- ① SUPPORT PIECE, 2" X 6" BY UNIT LENGTH (3 REQD). POSITION ON TOP OF THE STRAPPING BOARD OF A PALLET UNIT, OR THE CROSS PIECE OF THE TOP DUNNAGE ASSEMBLY, AS APPLICABLE.
- ② RETAINER PIECE, 2" X 4" X 55" (2 REQD). NAIL TO THE SUPPORT PIECES, PIECES MARKED ①, W/2-10d NAILS AT EACH JOINT.
- ③ PARTIAL-UNIT GATE (2 REQD). SEE THE "PARTIAL-UNIT GATE B" DETAIL BELOW. SEE GENERAL NOTE "M" ON PAGE 2 AND SPECIAL NOTE 3 AT LEFT.
- ④ STRUT, 4" X 4" BY UNIT LENGTH MINUS 6" (3 REQD). TOENAIL TO THE PARTIAL-UNIT GATE, PIECE MARKED ③, W/2-16d NAILS AT EACH END.
- ⑤ STRAPPING BOARD, 2" X 4" BY A LENGTH TO SUIT (2 REQD). NAIL TO THE STRUTS, PIECES MARKED ④, W/3-10d NAILS AT EACH JOINT.
- ⑥ UNITIZING STRAP, 1-1/4" X .031" OR .035" BY A LENGTH TO SUIT STEEL STRAPPING (2 REQD). PRE-POSITION.
- ⑦ SEAL FOR 1-1/4" STRAPPING (4 REQD, 2 PER JOINT). SEE GENERAL NOTE "N" ON PAGE 2.

**SPECIAL NOTES:**

1. SHIPMENTS OF PROPELLING CHARGES SHOULD CONSIST OF FULL-HEIGHT AND FULL-LAYER UNITS TO THE MAXIMUM EXTENT POSSIBLE. HOWEVER, THE END OF A LOT, OR THE QUANTITY OF ITEMS NEEDED TO FILL A REQUISITION, MAY NECESSITATE THE SHIPMENT OF ONE OR MORE LESS-THAN-FULL PALLET UNITS WITHIN A LOAD. THE PROCEDURES ON THIS PAGE ARE PRESENTED AS GUIDANCE IN THE SHIPMENT OF A PARTIAL UNIT WITHIN A CROSSWISE LOAD.
2. THE PALLET UNIT SHOWN IN THE SHIPMENT OF PARTIAL UNITS VIEW IS THE ROUTED DUNNAGE METHOD UNIT (BASIC HEIGHT). THE DEPICTED PROCEDURES ARE ALSO APPLICABLE FOR THE OTHER UNITS COVERED BY THIS DOCUMENT.
3. A LESS-THAN-FULL HEIGHT PALLET UNIT OF CROSSWISE-POSITIONED PROPELLING CHARGES WHICH IS TO BE SHIPPED WITHIN A LAYER OF A LOAD HAS NO LIMITATIONS AS TO THE NUMBER OF LAYERS ON THE PARTIAL UNIT. THE DEPICTED PROCEDURES SHOW THE BRACING OF A 2-LAYER UNIT WITHIN A 4-LAYER LOAD. THE PRINCIPLES CAN BE ADAPTED TO SUIT OTHER SIZE PARTIAL UNITS.
4. A PARTIAL UNIT MUST CONSIST OF FULL LAYERS OF FOUR (4) CONTAINERS, OR AN APPROVED FILLER ASSEMBLY, AS DETAILED BY DRAWING 19-48-4042A/1-20PM1001, MUST BE INSTALLED IN THE PLACE OF OMITTED CONTAINERS.
5. THE FILLERS AS REFERENCED IN SPECIAL NOTE 4 AND THE DUNNAGE DEPICTED ABOVE FOR THE SHIPMENT OF THE PARTIAL UNIT MAY BE REMOVED WHEN A SHIPMENT REACHES DESTINATION. OR IF DESIRED, THE FILLERS MAY REMAIN WITH THE UNIT DURING STORAGE (IF APPLICABLE) FOR POSSIBLE USE IN A FUTURE SHIPMENT.
6. THE "POSITIONING OF PARTIAL CROSSWISE UNIT IN A LAYER" VIEW ABOVE DEPICTS A PORTION OF A CONVENTIONAL BOX CAR LOAD, HOWEVER, THE PROCEDURES ARE ALSO APPLICABLE FOR LOADS IN CARS EQUIPPED WITH LOAD DIVIDER BULKHEADS.
7. FOR THE SHIPMENT OF A PARTIAL UNIT CONSISTING OF ONE OR TWO LAYERS, THE PROCEDURES SHOWN ON PAGE 120 MAY BE MORE ECONOMICAL.

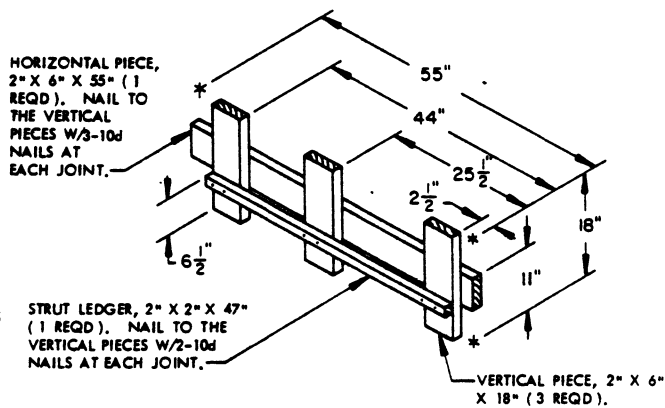

**PARTIAL-UNIT GATE B**

THE LOCATION OF THE VERTICAL PIECES MUST BE ADJUSTED TO MATCH THE VERTICAL PIECES OF THE APPLICABLE CENTER GATE, SO AS TO ALIGN WITH THE DUNNAGE PIECES OF A UNIT.

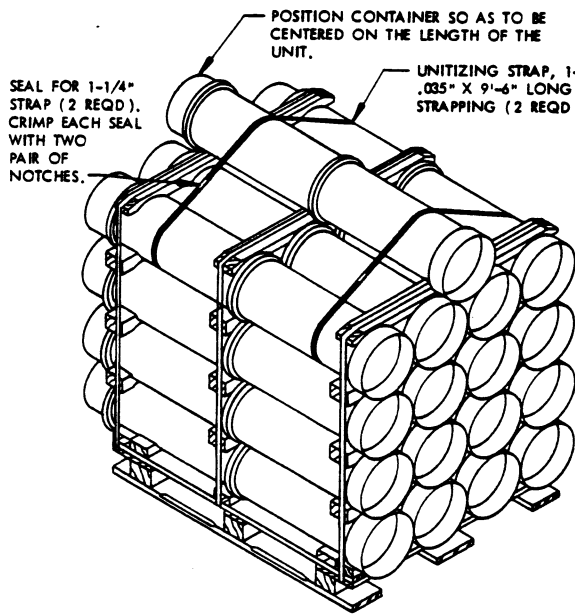

SECUREMENT OF ONE CONTAINER

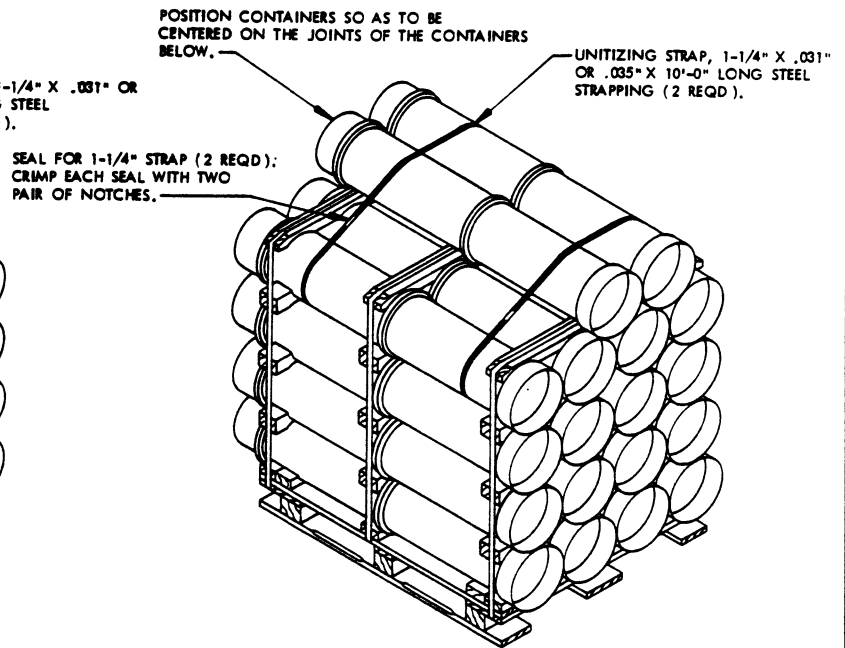

SECUREMENT OF TWO CONTAINERS

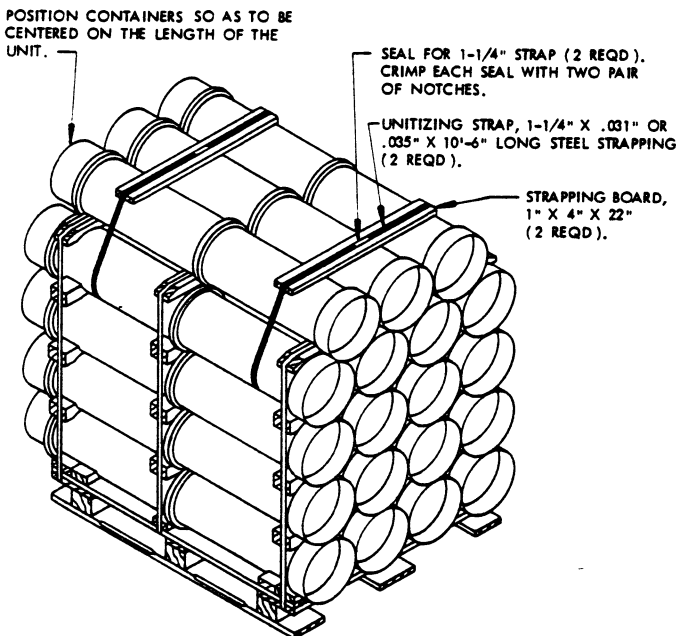

SECUREMENT OF THREE CONTAINERS

SPECIAL NOTES:

1. SHIPMENTS OF PROPELLING CHARGES SHOULD CONSIST OF FULL-HEIGHT AND FULL-LAYER UNITS TO THE MAXIMUM EXTENT POSSIBLE. HOWEVER, THE END OF A LOT, OR THE QUANTITY OF ITEMS NEEDED TO FILL A REQUISITION, MAY NECESSITATE THE SHIPMENT OF ONE OR MORE LEFTOVER CONTAINERS. LEFTOVER CONTAINERS ARE DESCRIBED AS A QUANTITY OF CONTAINERS WHICH IS INSUFFICIENT TO FORM A FULL-LAYERED PARTIAL UNIT FOR SHIPMENT EITHER ON TOP OF A LOAD AS SHOWN ON PAGE 120 OR WITHIN A LAYER AS SHOWN ON PAGES 117 AND 118.
2. SHIPMENT OF LEFTOVER CONTAINERS IS APPLICABLE FOR CONUS AND OCONUS RAILROAD SHIPMENTS FROM DEPOT TO DEPOT OR FROM DEPOT TO POSTS, CAMPS, AND STATIONS, OR, UPON APPROVAL FROM HIGHER HEADQUARTERS, FOR SHIPMENTS FROM LOAD, ASSEMBLY, AND PACK PLANTS TO DEPOTS. CAUTION: A LOAD CONTAINING LEFTOVER CONTAINERS IN AN AMOUNT WHICH IS LESS THAN A FULL LAYER, AND SECURED TO THE TOP OF A FULL OR PARTIAL UNIT, MUST NOT BE DESTINED FOR SHIPMENT OVERSEAS BY WATER CARRIER.
3. THE PALLET UNIT SHOWN IS THE ROUTED DUNNAGE METHOD UNIT (BASIC HEIGHT). THE DEPICTED PROCEDURES ARE ALSO APPLICABLE FOR THE OTHER UNITS COVERED BY THIS DOCUMENT.
4. FOR THE ALTERNATED CONTAINERS UNITS AND FOR THE FLAT DUNNAGE METHOD UNITS THE UNITIZING STRAP MUST NOT GO AROUND THE INTERMEDIATE DUNNAGE ASSEMBLY. THE STRAP MUST BE THREADED BEHIND THE 2" X 2" PIECES OF THE ASSEMBLIES.
5. OBVIOUSLY, A PALLET UNIT WITH ONE OR MORE CONTAINERS STRAPPED TO THE TOP MUST BE POSITIONED IN THE TOP LAYER OF A LOAD. THE PREFERRED LOCATION WOULD BE NEAR THE CENTER AREA OF A CAR IF A FULL LOAD IS BEING SHIPPED.
6. THE PROCEDURES ON THIS PAGE ARE APPLICABLE FOR THE SHIPMENT OF LEFTOVER CONTAINERS IN ANY OF THE LOADS DEPICTED HEREIN.

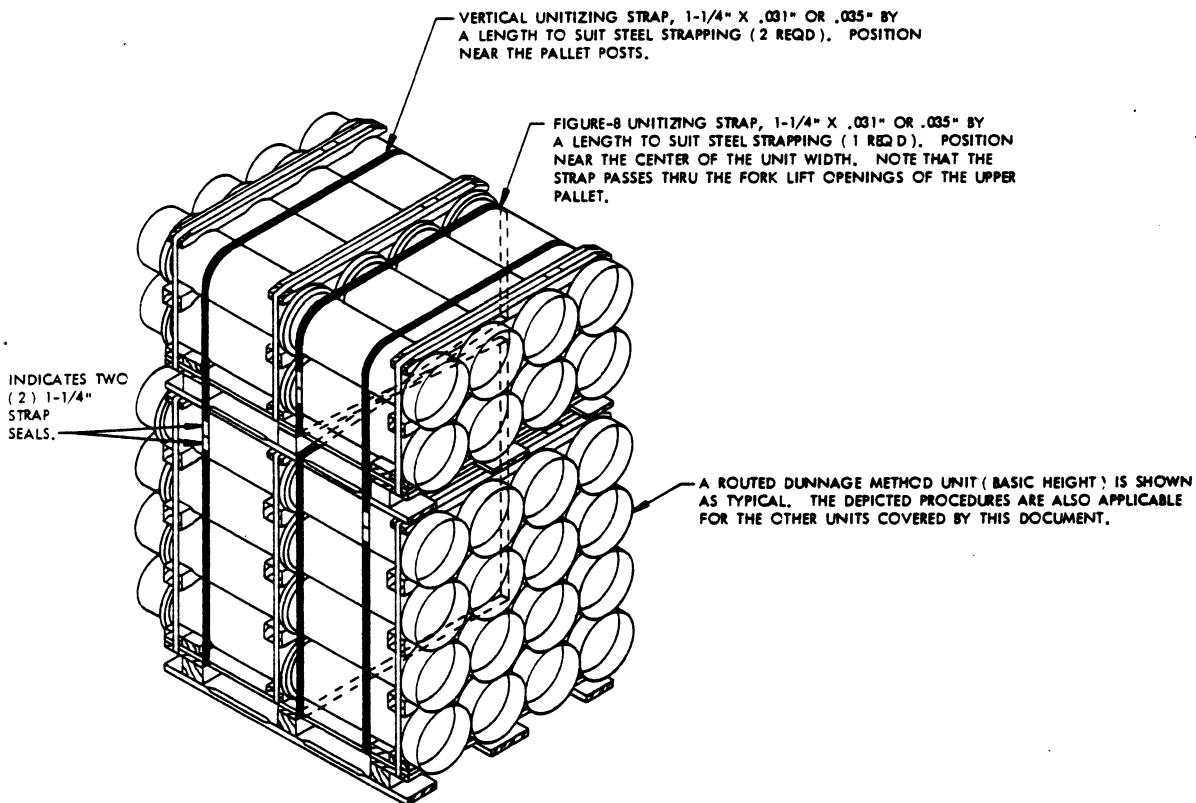

**SECUREMENT OF PARTIAL UNIT ON TOP**

THIS PROCEDURE IS APPLICABLE ONLY FOR USE IN A CROSSWISE LOAD. **CAUTION:** THE PARTIAL UNIT ON TOP IS LIMITED TO NOT MORE THAN TWO (2) LAYERS OF CONTAINERS. FOR SHIPMENT OF MORE THAN TWO LAYERS OF CONTAINERS, OR AN ALTERNATIVE METHOD FOR ONE OR TWO LAYERS, REFER TO THE PROCEDURES ON PAGE 118.



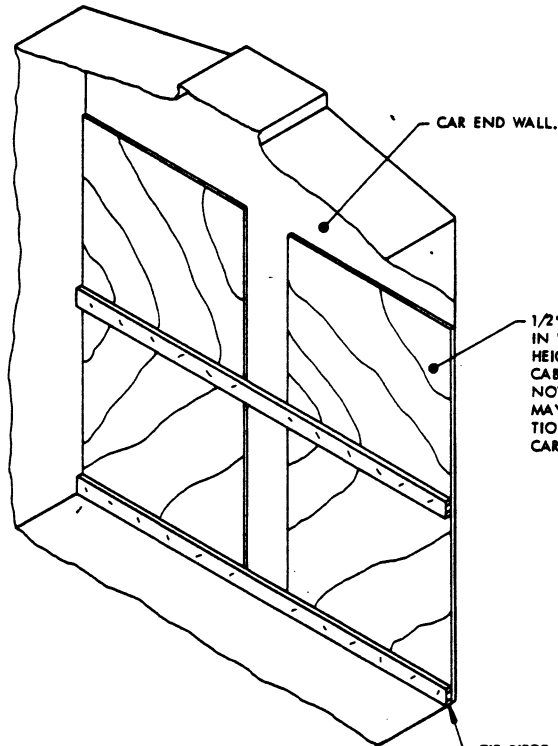

CAR END WALL.

1/2" MINIMUM THICK PLYWOOD, UNIT LENGTH IN WIDTH (48" WIDE MAY BE USED) BY LOAD HEIGHT. NAIL TO THE TIE PIECES W/1-APPLICABLY SIZED NAIL EVERY 8" AND CLINCH. NOTE THAT THE APPLICABLE SEPARATOR GATE MAY BE USED IN LIEU OF PLYWOOD. POSITION WITH THE VERTICAL PIECES AGAINST THE CAR END WALL.

TIE PIECE, 1" X 4" BY CAR WIDTH MINUS 1" (MINIMUM OF 2 REQD).

**END-WALL LINING**

THIS VIEW DEPICTS LINING REQUIRED FOR A LENGTHWISE LOAD IN A CAR EQUIPPED WITH A STEEL END WALL.

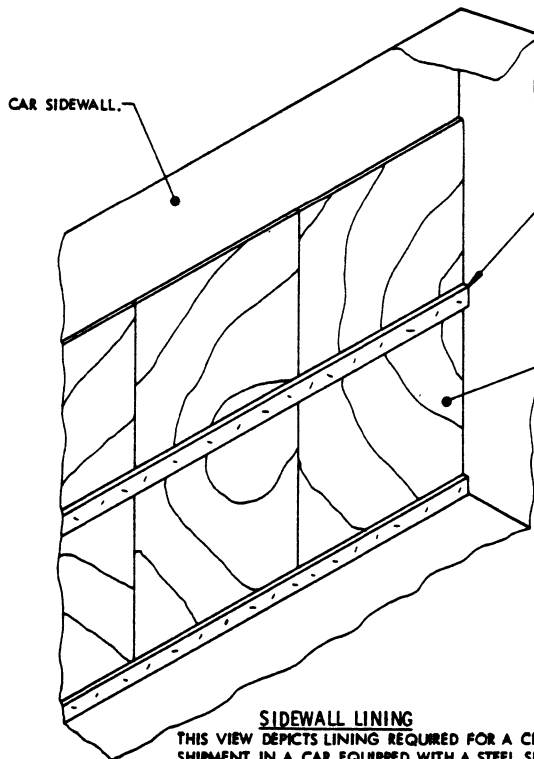

CAR SIDEWALL.

TIE PIECE, 1" X 4" BY RANDOM LENGTH. LOCATE SO AS TO BE UNDER THE "OVERHANG" OF THE PALLET UNITS. NOTE THAT THE UPPER 1" X 4" PIECE MAY BE POSITIONED ABOVE THE TOP OF THE LOAD.

1/4" MINIMUM PLYWOOD, 1/8" MINIMUM HARDBOARD, OR .060" MINIMUM THICK SOLID WALL FIBERBOARD. NAIL PLYWOOD OR HARDBOARD TO 1" X 4" W/1 APPLICABLY SIZED NAIL EVERY 8". STAPLE FIBERBOARD TO 1" X 4" W/1 STAPLE EVERY 6". NOTE THAT SEPARATOR GATES, OR SIMILARLY POSITIONED VERTICAL 1" X 6" LUMBER, MAY BE USED PROVIDING THEY ARE TIED TOGETHER TO PREVENT DISLODGEMENT.

**SIDEWALL LINING**

THIS VIEW DEPICTS LINING REQUIRED FOR A CROSSWISE SHIPMENT IN A CAR EQUIPPED WITH A STEEL SIDEWALL. NOTE THAT IF THE CAR IS EQUIPPED WITH A STEEL-FACED PLUG DOOR, THE SPECIAL LINING WILL ALSO BE REQUIRED IN THE DOORWAY AREA IF THE SPECIFIED DOORWAY PROTECTION DOES NOT SUFFICE.

PLYWOOD, 3/8" X 48" WIDE BY A HEIGHT TO SUIT (2 REQD).  
NAIL TO EACH TIE PIECE W/3-4d NAILS AT EACH JOINT AND CLINCH.

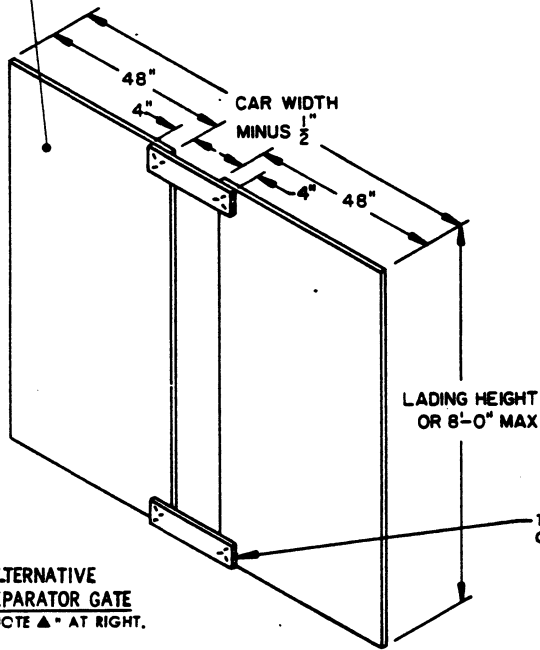

**ALTERNATIVE  
SEPARATOR GATE**  
SEE "NOTE ▲" AT RIGHT.

**NOTE ▲:**  
THE ALTERNATIVE SEPARATOR GATE MAY BE USED IN LIEU OF THE SEPARATOR GATE SHOWN WITHIN A LOAD, WHICH IS FABRICATED FROM 1" X 4" AND 1" X 6" MATERIAL. THE ALTERNATIVE SEPARATOR GATE CAN ONLY BE USED IN LOADS WHICH ARE ONE OR TWO PALLET UNITS IN HEIGHT; PLYWOOD SEPARATOR GATES ARE NOT ECONOMICALLY FEASIBLE FOR A 3-LAYER LOAD.

TIE PIECE, 1" X 6" BY  
CUT TO FIT (2 REQD).

LADING HEIGHT  
OR 8'-0" MAX

**NOTE ○:**  
IF A BOX CAR TO BE LOADED HAS BOWED END WALLS WHICH ARE BOWED OUTWARD MORE THAN TWO INCHES (2"), EITHER FROM SIDE TO SIDE OR FROM FLOOR TO ROOF, AN END-OF-CAR BULKHEAD MUST BE INSTALLED TO PROVIDE A "SQUARED OFF" SURFACE FOR THE LOAD AT THE END OF THE CAR. THE BULKHEAD IS APPLICABLE FOR USE AT THE END OF A LOAD IN A CONVENTIONAL BOX CAR OR IN A CAR EQUIPPED WITH LOAD DIVIDER BULKHEADS, OR AT THE END OF A CAR EQUIPPED WITH MECHANICAL BRACING DEVICES, IF DESIRED, IN LIEU OF USING CROSS MEMBERS. THE BULKHEAD MAY BE FABRICATED FROM A CENTER GATE FOR THE UNIT THAT IS TO BE LOADED AND FOR THE UNIT POSITIONING (LENGTHWISE OR CROSSWISE). NOTE THAT THE GATE MUST BE MODIFIED BY OMITTING THE 2" X 2" STRUT LEDGERS AND THE GATE HOLD DOWN PIECES. A MODIFIED CENTER GATE "L", AS DETAILED ON PAGE 46, IS SHOWN AS TYPICAL.

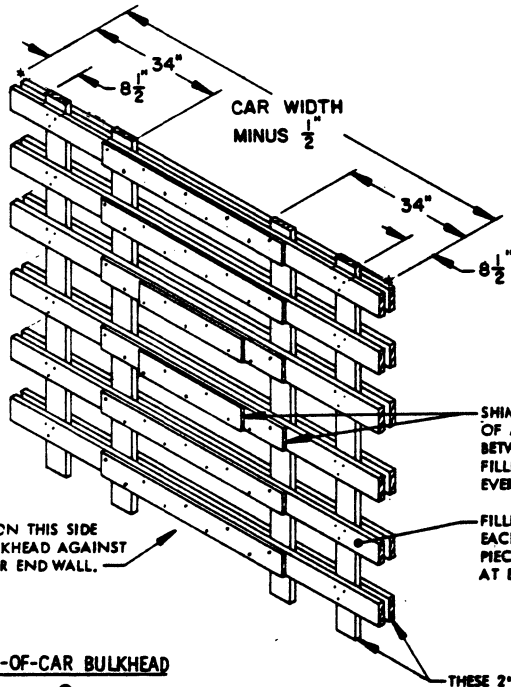

POSITION THIS SIDE  
OF BULKHEAD AGAINST  
THE CAR END WALL.

**END-OF-CAR BULKHEAD**  
SEE "NOTE ○" AT RIGHT.

THESE 2" X 6" HORIZONTAL PIECES AND 2" X 6" VERTICAL PIECES ARE PART  
OF THE MODIFIED CENTER GATE. SEE "NOTE ○" ABOVE.

SHIM MATERIAL, 6" WIDE PLYWOOD OR DIMENSIONAL LUMBER  
OF A THICKNESS AND LENGTH AS REQUIRED TO FILL THE VOID  
BETWEEN THE CAR END WALL AND THE BULKHEAD. NAIL TO THE  
FILLER PIECE AND/OR LAMINATE W/1 APPLICABLY SIZED NAIL  
EVERY 6".

FILLER PIECE, 2" X 6" BY CAR WIDTH MINUS 1/2" IN LENGTH (ONE REQUIRED FOR  
EACH HORIZONTAL PIECE ON THE CENTER GATE). ALIGN WITH THE HORIZONTAL  
PIECES AND NAIL TO THE VERTICAL PIECES OF THE CENTER GATE W/3-10d NAILS  
AT EACH JOINT.

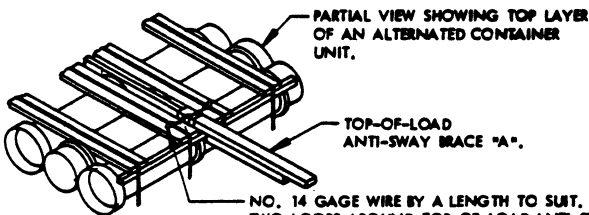

**TIRE WIRE APPLICATION A**

NO. 14 GAGE WIRE BY A LENGTH TO SUIT. FORM  
TWO LOOPS AROUND TOP-OF-LOAD ANTI-SWAY  
BRACE AND TWIST TO PREVENT DISPLACEMENT. THREAD  
EACH END OF WIRE UNDER AND AROUND A UNITIZING  
STRAP ON THE UNIT AND TWIST WIRE TO SELF, AS SHOWN.

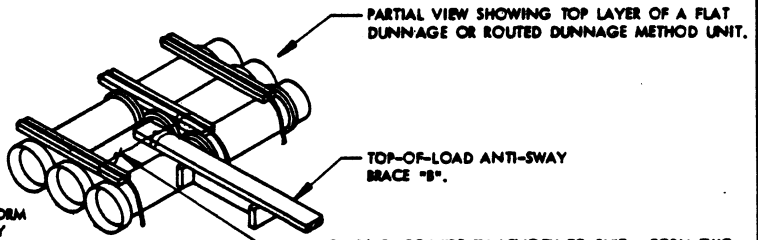

**TIE WIRE APPLICATION B**

NO. 14 GAGE WIRE BY LENGTH TO SUIT. FORM TWO  
LOOPS AROUND TOP-OF-LOAD ANTI-SWAY BRACE AND  
TWIST TO PREVENT DISLODGEEMENT. THREAD EACH  
END OF WIRE UNDER AND AROUND A STRAPPING BOARD  
ON THE UNIT AND TWIST WIRE TO SELF, AS SHOWN.

PLYWOOD, 1/2" THICK BY THE UNIT WIDTH OR LENGTH BY THE LOAD HEIGHT (2 REQD). NAIL TO THE VERTICAL PIECES W/1-6d NAIL EVERY 6".  
**NOTE:** THE WIDTH OF THE PLYWOOD WILL BE UNIT WIDTH IF THE LENGTH OF THE UNIT IS PARALLEL WITH THE SIDEWALL OF A CAR, AS TYPICALLY SHOWN IN THE LOAD ON PAGE 10, OR UNIT LENGTH IF THE WIDTH OF THE UNIT IS PARALLEL WITH THE SIDEWALL OF A CAR, AS TYPICALLY SHOWN IN THE LOAD ON PAGE 8. PLYWOOD MAY BE ALLOWED TO EXTEND BEYOND THE UNIT LENGTH OR WIDTH, IF DESIRED.

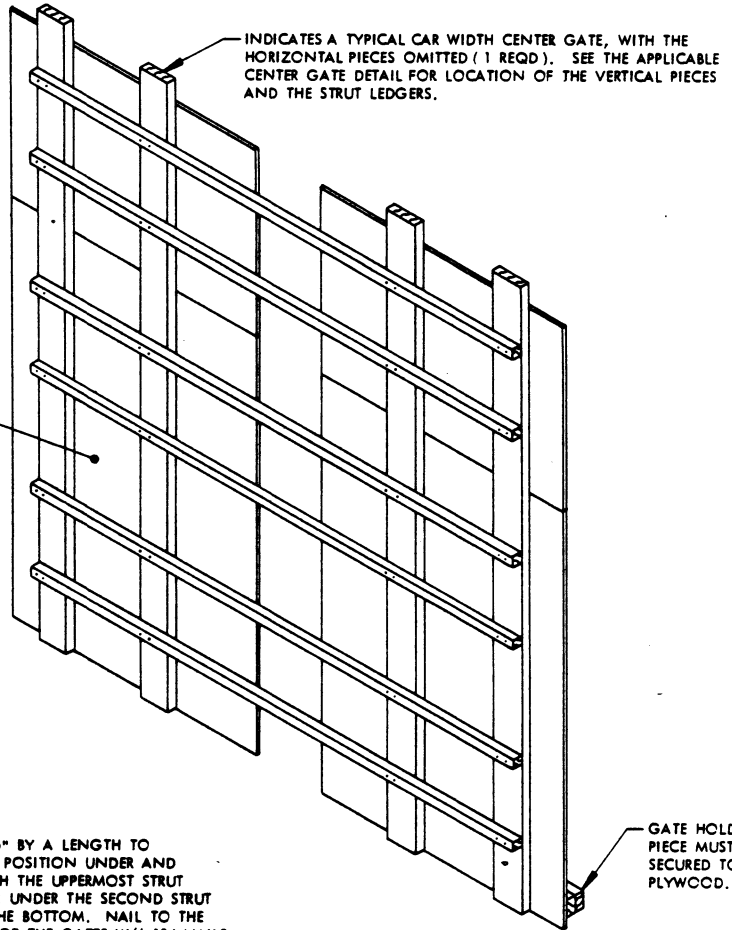

TIE PIECE, 2" X 6" BY A LENGTH TO SUIT (2 REQD). POSITION UNDER AND IN CONTACT WITH THE UPPERMOST STRUT LEDGERS AND/OR UNDER THE SECOND STRUT LEDGERS FROM THE BOTTOM. NAIL TO THE VERTICAL PIECES OF THE GATES W/4-10d NAILS AT EACH JOINT.

**PLYWOOD CENTER GATE ALTERNATIVE**  
 CENTER GATE "C" IS SHOWN AS TYPICAL. PLYWOOD MAY BE USED IN LIEU OF THE HORIZONTAL PIECES ON ANY CENTER GATE DEPICTED HEREIN, INCLUDING THOSE WHICH ARE FOR THE BRACING OF A SINGLE ROW.

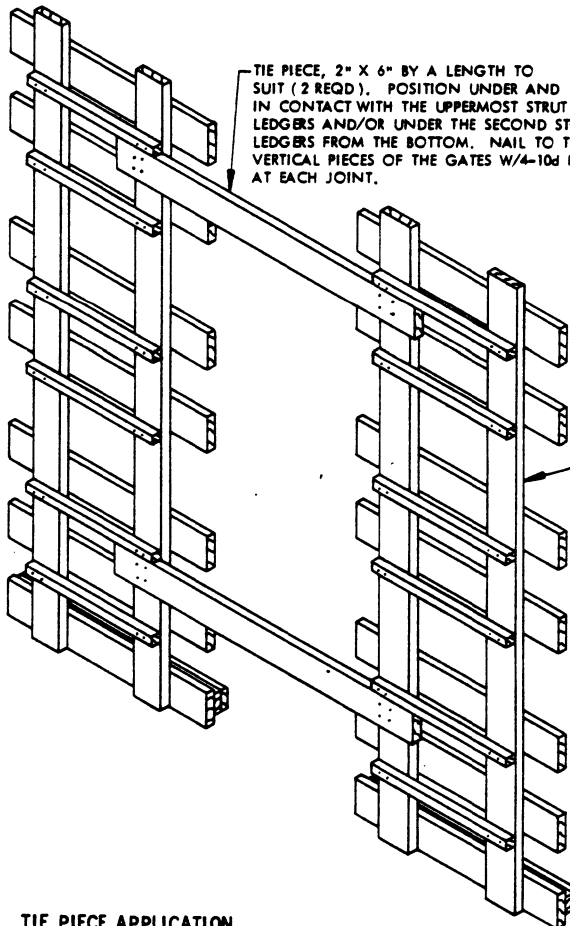

INDICATES A TYPICAL CENTER GATE FOR A SINGLE ROW (2 REQD). SEE THE APPLICABLE CENTER GATE DETAIL FOR THE UNIT BEING SHIPPED. A GATE FOR UNITS WHICH ARE POSITIONED WITH THE UNIT WIDTH PARALLEL TO THE CAR SIDEWALL IS SHOWN. THE PROCEDURE IS ALSO APPLICABLE TO GATES FOR UNITS WHICH ARE POSITIONED WITH THE UNIT LENGTH PARALLEL TO THE CAR SIDEWALL.

**TIE PIECE APPLICATION**

THIS PROCEDURE IS APPLICABLE FOR USE WITH ANY TWO CENTER GATES FOR SINGLE ROWS OF PALLET UNITS. NOTE THAT THE TIE PIECES SHOULD BE APPLIED AFTER THE GATES AND STRUTS HAVE BEEN INSTALLED.

**DETAILS**

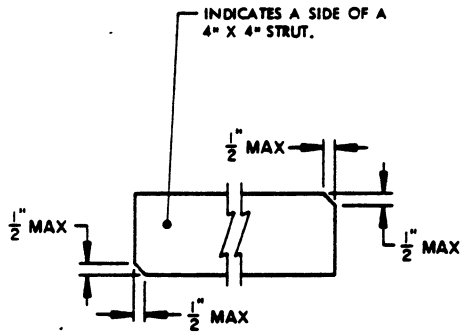

**BEVEL-CUT**

BEVEL CUTTING THE STRUTS AS SPECIFIED WILL FACILITATE INSTALLING THE STRUTS WITH A "DRIVE FIT". CAUTION: DO NOT BEVEL A CORNER MORE THAN ONE-HALF INCH (1/2").

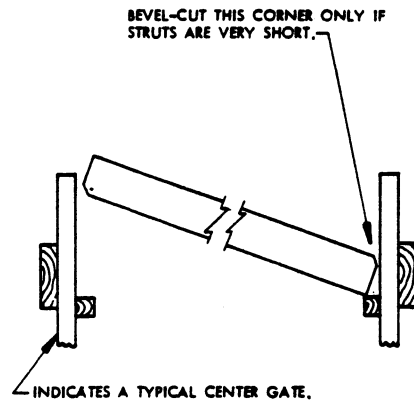

**STRUT INSTALLATION**

SEE GENERAL NOTE "7" ON PAGE 2 FOR ADDITIONAL STRUT INSTALLATION GUIDANCE.

HORIZONTAL STRUT BRACING, 2" X 4" BY A LENGTH TO SUIT (AS REQD). NAIL TO THE STRUTS W/3-10d NAILS AT EACH JOINT.

A CENTER GATE FOR A 2-LAYER LOAD OF CROSSWISE POSITIONED PALLETS IS SHOWN AS TYPICAL.

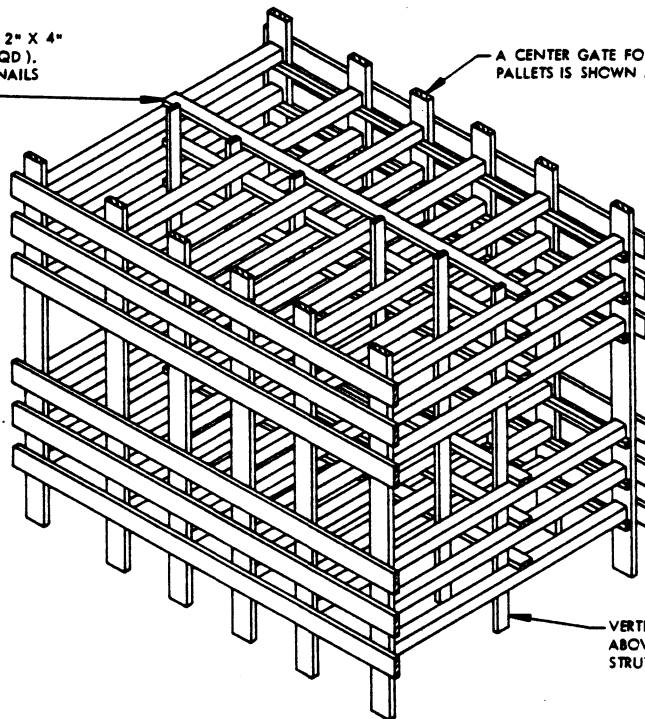

VERTICAL PIECE, 2" X 4" BY A LENGTH TO EXTEND 2" ABOVE THE TOP STRUT (AS REQD). NAIL TO THE STRUTS W/3-10d NAILS AT EACH JOINT.

**TYPICAL STRUT BRACING**  
SEE GENERAL NOTE "5" ON PAGE 2.

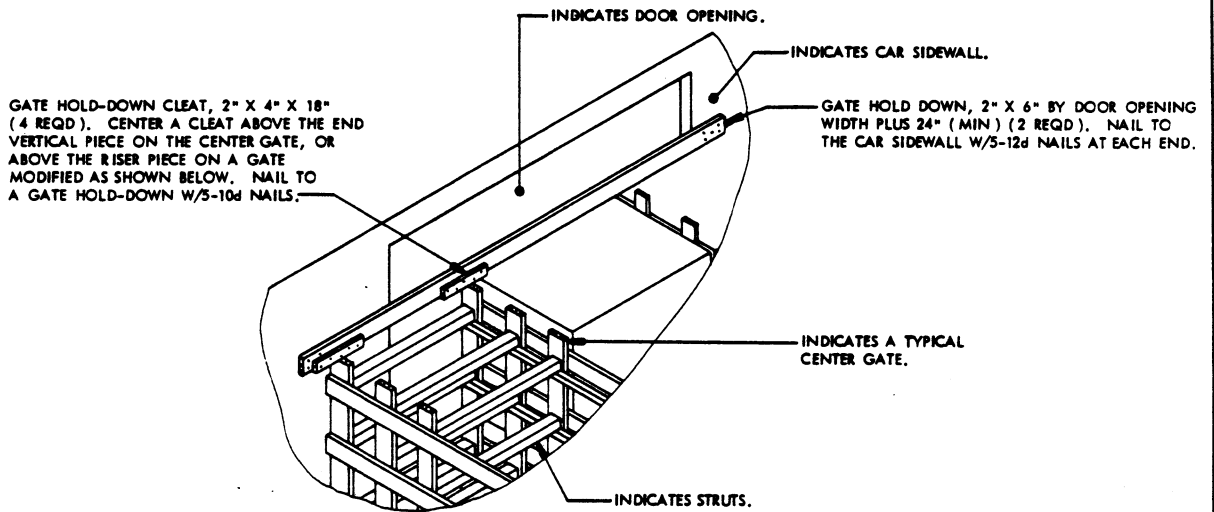

**ALTERNATIVE GATE HOLD-DOWN**

THIS VIEW DEPICTS AN ALTERNATIVE METHOD OF CENTER GATE HOLD DOWN WHICH CAN BE USED IF DESIRED, PROVIDING THE CAR HAS MAILABLE SIDEWALLS. THIS METHOD MAY BE APPLIED IN LIEU OF USING THE GATE HOLD DOWN PIECES WHICH ARE PART OF A CENTER GATE, OR IN LIEU OF THE 2" X 4" GATE HOLD DOWN PIECES WHICH SPAN THE CENTER VOID AREA AND ARE NAILED TO THE CENTER GATES. **NOTE:** FOR A GATE NOT LOCATED IN OR NEAR THE DOORWAY AREA, THE GATE HOLD-DOWN CLEAT MAY BE DOUBLED AND NAILED TO THE CAR SIDEWALL TO PROVIDE A HOLD-DOWN.

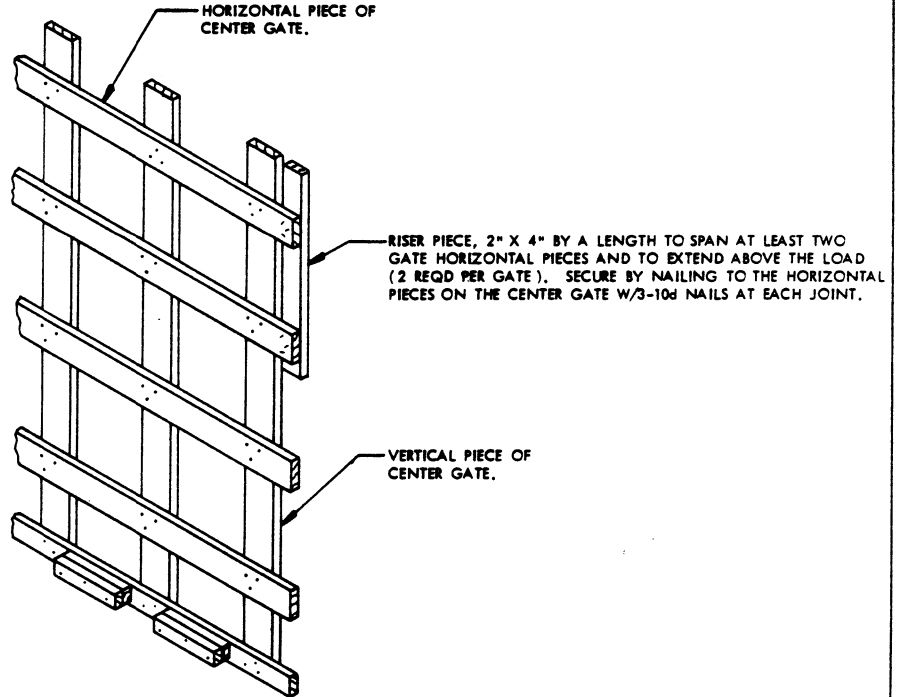

**CENTER GATE MODIFICATION**

THE MODIFICATION PROCEDURES SHOWN IN THIS VIEW ARE APPLICABLE FOR THE CENTER GATES WHICH HAVE THE VERTICAL PIECES INSET FROM THE END OF THE HORIZONTAL PIECES AS SHOWN ABOVE. THE RISER PIECE WILL PROVIDE A MEANS FOR CONTACTING THE GATE WITH THE GATE HOLD-DOWN AS SHOWN IN THE "ALTERNATIVE GATE HOLD-DOWN" DETAIL AT THE TOP OF THIS PAGE.

**DETAILS**

IF THE SPACE WILL BE MORE THAN THE 9" MAXIMUM, REFER TO THE "ALTERNATIVE DOORWAY PROTECTION A-2" VIEW BELOW FOR GUIDANCE. SEE "NOTE ●" AT THE RIGHT.

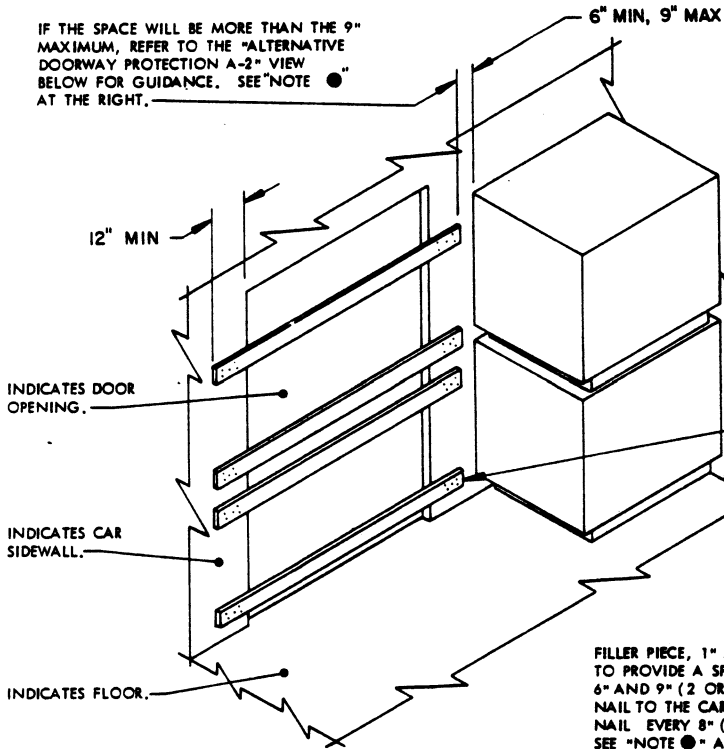

**NOTE ● :**

THE TOLERANCE DIMENSION (6" MIN, 9" MAX) IS ALLOWED TO PROVIDE FOR CLEARANCE DURING THE NORMAL LONGITUDINAL SHIFTING OF A LOAD IN TRANSIT, AND IS APPLICABLE WHEN ANTI-SWAY BRACING IS USED FOR A LOAD AND ALSO WHEN THE EXCESS SPACE ACROSS THE CAR IS SMALL ENOUGH THAT ANTI-SWAY BRACING OF ANY KIND IS NOT REQUIRED. IF AN EXCESS LATERAL SPACE IS FILLED BY NAILING LUMBER TO THE CAR SIDEWALL, AS IS PERMITTED FOR THE LOADS ON PAGES 66 AND 70, THE DOOR SPANNERS WILL BE POSITIONED TO BUTT AGAINST THE FILL MATERIAL AND THE TOLERANCE DIMENSION WILL NOT APPLY. ALSO, THE FILLER PIECES SHOWN IN THE ALTERNATIVE DOORWAY PROTECTION A-2 VIEW WILL NOT BE USED. NOTE THAT THE THICKNESS OF THE DOOR SPANNER PIECES MUST EQUAL THE THICKNESS OF THE LUMBER FILL MATERIAL THAT IS NAILED TO THE CAR SIDEWALL.

**ALTERNATIVE DOORWAY PROTECTION A-1**

THIS METHOD OF DOORWAY PROTECTION IS FOR USE IN CARS HAVING NAILABLE SIDEWALLS AND EQUIPPED WITH CONVENTIONAL SLIDING DOORS, AND IS APPLICABLE ONLY FOR THE SIDE OPPOSITE THE LOADING SIDE OF THE CAR. THE METHOD CAN ALSO BE USED IN CARS EQUIPPED WITH PLUG DOORS; HOWEVER, A METHOD OTHER THAN THE "ALTERNATIVE DOORWAY PROTECTION A-3" PROCEDURES BELOW MUST BE USED ON THE LOADING SIDE OF THE CAR, SUCH AS THE "ALTERNATIVE DOORWAY PROTECTION C" PROCEDURES ON PAGE 127 OR THE NAILED-DOWN BLOCKING AND STEEL STRAPPING METHOD DEPICTED BY THE "ALTERNATIVE DOORWAY PROTECTION E" AND "ALTERNATIVE DOORWAY PROTECTION F" DETAILS ON PAGE 128.

DOOR SPANNER, 1" X 6" BY DOOR OPENING WIDTH PLUS 24" (2 REQD PER LAYER). POSITION SO AS TO MATCH THE HEIGHTS SPECIFIED FOR THE HORIZONTAL PIECES OF THE APPLICABLE DOORWAY PROTECTION DETAIL. NAIL TO THE CAR SIDEWALL W/5-6d NAILS AT EACH END. SEE "NOTE ●" ABOVE.

DOOR SPANNER, 2" (MIN) X 6" BY DOOR OPENING WIDTH PLUS 24" (2 REQD PER LAYER). POSITION SO AS TO MATCH THE HEIGHTS SPECIFIED FOR THE HORIZONTAL PIECES OF THE APPLICABLE DOORWAY PROTECTION DETAIL. SEE "NOTE ●" ABOVE.

INDICATES DOOR OPENING.

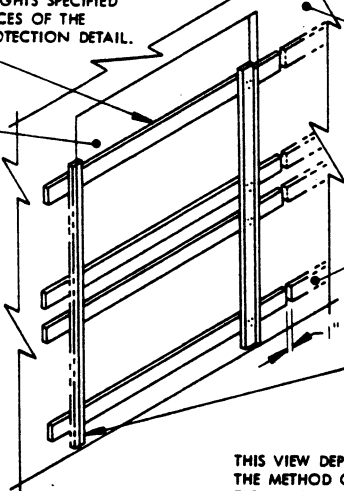

FILLER PIECE, 1" X 6" BY A LENGTH TO PROVIDE A SPACE OF BETWEEN 6" AND 9" (2 OR 4 REQD PER LAYER). NAIL TO THE CAR SIDEWALL W/1-6d NAIL EVERY 8" (MINIMUM OF 2 NAILS). SEE "NOTE ●" ABOVE.

SEE "NOTE ●" ABOVE.

**ALTERNATIVE DOORWAY PROTECTION A-2**

THIS METHOD OF DOORWAY PROTECTION IS FOR USE IN CARS HAVING NAILABLE SIDEWALLS AND EQUIPPED WITH CONVENTIONAL SLIDING DOORS, AND IS APPLICABLE ONLY FOR THE SIDE OPPOSITE THE LOADING SIDE OF THE CAR. SEE THE NOTE UNDER THE "A-1" PROCEDURES.

INDICATES FILL MATERIAL NAILED TO THE SIDEWALL, OR A FILLER PIECE, 2" X 6" BY A LENGTH TO EQUAL THE LENGTH OF THE FILLER PIECE ON THE OPPOSITE SIDEWALL MINUS 1" (QUANTITY TO BE THE SAME AS FOR THE DOOR SPANNERS AND/OR FILLER PIECES ON THE OPPOSITE SIDEWALL). SEE "NOTE ●" ABOVE.

SUPPORT PIECE, 2" X 4" BY A LENGTH TO SUIT (2 REQD). POSITION AGAINST DOOR POST AND NAIL TO THE DOOR SPANNER PIECES W/3-10d NAILS AT EACH JOINT.

**ALTERNATIVE DOORWAY PROTECTION A-3**

THIS VIEW DEPICTS THE DOOR OPENING OF A CAR AS IT APPEARS WHEN LOOKING AT IT FROM OUTSIDE OF THE CAR. THE METHOD OF DOORWAY PROTECTION IS FOR USE IN CARS HAVING NAILABLE SIDEWALLS AND EQUIPPED WITH CONVENTIONAL SLIDING DOORS, AND IS APPLICABLE FOR THE LOADING SIDE OF THE CAR. NOTE THAT THE ADJACENT PALLET UNITS MUST BE POSITIONED APPROXIMATELY 1-3/4" (REF) FROM THE CAR SIDEWALL (1/4" MORE THAN THE THICKNESS OF THE DOOR SPANNER PIECES) TO FACILITATE THE INSTALLATION OF THESE DOOR SPANNER PIECES. THE VIEW SHOWN ABOVE IS FOR A TWO LAYER LOAD.

HORIZONTAL PIECE, 1" X 6", BY DOOR OPENING WIDTH (2 REQD PER LAYER). NAIL TO THE VERTICAL PIECES W/3-6d NAILS AT EACH END. SEE THE APPLICABLE DOORWAY PROTECTION DETAIL FOR HEIGHT LOCATION.

VIEW B

VERTICAL PIECE, 2" X 3" BY A LENGTH TO SUIT (2 REQD).

INDICATES DOOR OPENING.

INDICATES CAR SIDEWALL.

DOORWAY PROTECTION-GATE STRAP, 1-1/4" X .035" X 3'-0" (REF) NAIL-ON TYPE STEEL STRAPPING (4 REQD PER LAYER OF LOAD). NAIL TO GATE AND CAR SIDEWALL AS SHOWN BY THE "VIEW B" SKETCH BELOW. NOTE THAT TYPE 1 STRAPPING MAY BE PUNCHED FOR NAILING IF TYPE 2 STRAPPING IS NOT AVAILABLE.

INDICATES FLOOR.

INDICATES LOCATION OF 7 (MIN) 4d NAILS PER STRAP.

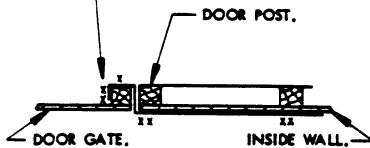

VIEW B

THIS VIEW DEPICTS THE LOCATION OF THE NAILS FOR SECURING THE DOORWAY-PROTECTION-GATE STRAP. NOTE THAT THE STRAPS MUST BE APPLIED TO THE CAR SIDEWALL PRIOR TO POSITIONING THE ADJACENT UNITS.

**ALTERNATIVE DOORWAY PROTECTION B**

THIS METHOD OF DOORWAY PROTECTION IS FOR USE IN CARS EQUIPPED WITH CONVENTIONAL SLIDING DOORS WHEN THE DOOR POSTS ARE STEEL WITHOUT NAILING HOLES AND THE CAR SIDEWALLS ARE NAILABLE. THE VIEW SHOWN ABOVE IS FOR A THREE-LAYER LOAD.

DOORWAY PROTECTION STRAP, 1-1/4" X .035" STEEL STRAPPING BY DOOR OPENING WIDTH PLUS 8'-0" IN LENGTH (2 REQD PER LAYER). INSTALL FROM TWO (2) PIECES. THREAD ONE END THRU A STRAP ANCHOR PLATE AS SHOWN BY THE "APPLICATION OF STRAPPING TO STRAP ANCHOR PLATE" DETAILS BELOW. NAIL STRAP ANCHOR PLATE TO CAR SIDEWALL W/4-SIGNODE NUMBER 27 RINGLOCK NAILS.

SEAL FOR 1-1/4" STRAP (2 REQD PER STRAP). DOUBLE CRIMP EACH SEAL WITH TWO PAIR OF CRIMPS.

INDICATES DOOR OPENING.

INDICATES CAR SIDEWALL.

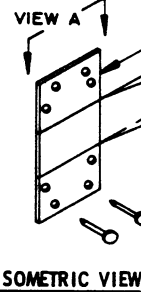

INDICATES STRAP ANCHOR PLATE.

DOOR SPANNER END OF STRAP.

ISOMETRIC VIEW

VIEW A

**APPLICATION OF STRAPPING TO STRAP ANCHOR PLATE**

THESE VIEWS DEPICT THE PROPER THREADING OF A DOORWAY PROTECTION STRAP THRU AN ANCHOR PLATE.

**ALTERNATIVE DOORWAY PROTECTION C**

THIS METHOD OF DOORWAY PROTECTION IS ONLY FOR USE WITH THOSE LOADS IN WHICH THE PALLET UNITS ARE POSITIONED CROSSWISE. THE METHOD MAY BE USED IN CARS EQUIPPED WITH EITHER PLUG TYPE DOORS OR CONVENTIONAL SLIDING DOORS, BUT ONLY IF THE CAR IS EQUIPPED WITH NAILABLE SIDEWALLS. IF THE CAR IS EQUIPPED WITH SPECIAL ANCHOR RODS IN THE CAR DOOR POSTS, THE DOORWAY PROTECTION STRAPS MAY BE SECURED TO THESE RODS IN LIEU OF ATTACHING TO THE CAR SIDEWALL WITH STRAP ANCHOR PLATES. **CAUTION:** A VERTICAL PIECE MUST BE ADDED TO EACH END OF A CENTER GATE WHICH IS IN OR WITHIN SIX INCHES (6") OF BEING IN THE DOOR OPENING, TO PREVENT THE GATE FROM SHIFTING Laterally, UNLESS PLYWOOD IS BEING USED IN LIEU OF THE 2" X 6" HORIZONTAL PIECES IN WHICH CASE THE ADDED VERTICAL PIECES WILL NOT BE REQUIRED.

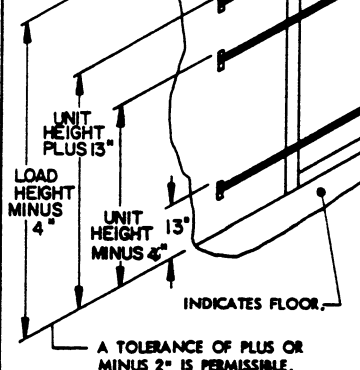

**DOORWAY PROTECTION**

DOOR SPANNER, 2" X 6" BY DOOR OPENING WIDTH PLUS 24" (1 REQD.). POSITION ABOVE THE LOAD AND NAIL THRU A FILLER BLOCK INTO A VERTICAL PIECE W/3-12d NAILS AT EACH JOINT. NAIL TO THE CAR SIDEWALL W/3-12d NAILS AT EACH END. (OPTIONAL).

FILLER BLOCK, 1" X 4" X 9" (2 REQD.). NAIL TO A VERTICAL PIECE W/4-6d NAILS.

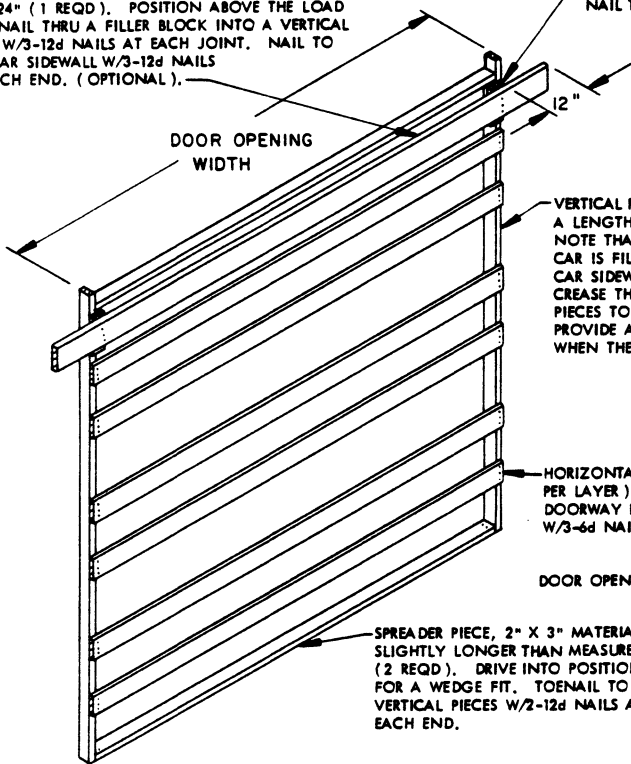

DOOR OPENING WIDTH

VERTICAL PIECE, 2" X 3" BY A LENGTH TO SUIT (2 REQD.). NOTE THAT IF THE EXCESS SPACE ACROSS A CAR IS FILLED BY NAILING LUMBER TO THE CAR SIDEWALL, IT MAY BE NECESSARY TO INCREASE THE VERTICAL PIECES AND THE SPREADER PIECES TO 2" X 4" OR 2" X 6" MATERIAL. THIS WILL PROVIDE A SURFACE TO WEDGE BETWEEN THE DOOR POSTS WHEN THE GATE IS MOVED INWARD TO CONTACT THE LADING.

HORIZONTAL PIECE, 1" X 6" BY DOOR OPENING WIDTH (2 REQD PER LAYER). LOCATE AT HEIGHTS AS SPECIFIED BY THE APPLICABLE DOORWAY PROTECTION DETAIL. NAIL TO THE VERTICAL PIECES W/3-6d NAILS AT EACH END.

SPREADER PIECE, 2" X 3" MATERIAL CUT SLIGHTLY LONGER THAN MEASURED DISTANCE (2 REQD.). DRIVE INTO POSITION TO PROVIDE FOR A WEDGE FIT. TOENAIL TO THE VERTICAL PIECES W/2-12d NAILS AT EACH END.

FILLER CLEAT, 1" X 6" BY CUT TO FIT (1 REQD.). NAIL TO STRAPPING BOARD W/1-6d NAIL EVERY 12".

STRAPPING BOARD, 2" X 6" BY LOAD WIDTH (1 REQD.). NAIL TO 2" X 4" FILLER CLEAT W/3-10d NAILS AT EACH END.

STRAPPING BOARD

FILLER CLEAT, 2" X 4" X 12" (2 REQD.).

**ALTERNATIVE DOORWAY PROTECTION D**

THIS METHOD OF DOORWAY PROTECTION IS FOR USE IN CARS EQUIPPED WITH CONVENTIONAL SLIDING DOORS WHEN THE DOOR POSTS ARE NOT NAILABLE. IF THE CAR HAS NAILABLE SIDEWALLS, NAIL-ON TYPE STRAPPING MAY BE USED TO SECURE THE GATE IN LIEU OF USING THE SPREADER PIECES. SEE THE "ALTERNATIVE DOORWAY PROTECTION B" DETAIL ON PAGE 127 FOR GUIDANCE. NOTE THAT THE DOOR SPANNER IN THIS DETAIL MAY BE USED AS A GATE HOLD-DOWN PIECE FOR THE "ALTERNATIVE GATE HOLD-DOWN METHOD SHOWN ON PAGE 125.

STRAPPING BOARD (AS REQD.). SEE THE DETAIL ABOVE.

BUNDLING STRAP, 1-1/4" X .035" OR .031" BY A LENGTH TO SUIT STEEL STRAPPING (AS REQD.). STAPLE TO STRAPPING BOARD W/3 STAPLES. SEE "NOTE #\*" BELOW.

BATTEN.

SPACER ASSEMBLY (AS REQD.). SEE THE DETAIL AT RIGHT.

SIDE BLOCKING, 2" X 4" X 40" (DOUBLED) (2 REQD FOR EACH LOAD UNIT REQUIRING ONE OR TWO BUNDLING STRAPS.) NAIL THE FIRST PIECE TO THE CAR FLOOR W/3 16d NAILS. NAIL THE SECOND PIECE TO THE FIRST IN A LIKE MANNER.

BATTEN FOR CONTAINER END, 2" X 4" X 40" OR A LENGTH TO SUIT (DOUBLED) (2 REQD.). LAMINATE W/1-10d NAIL EVERY 8".

**ALTERNATIVE DOORWAY PROTECTION E**

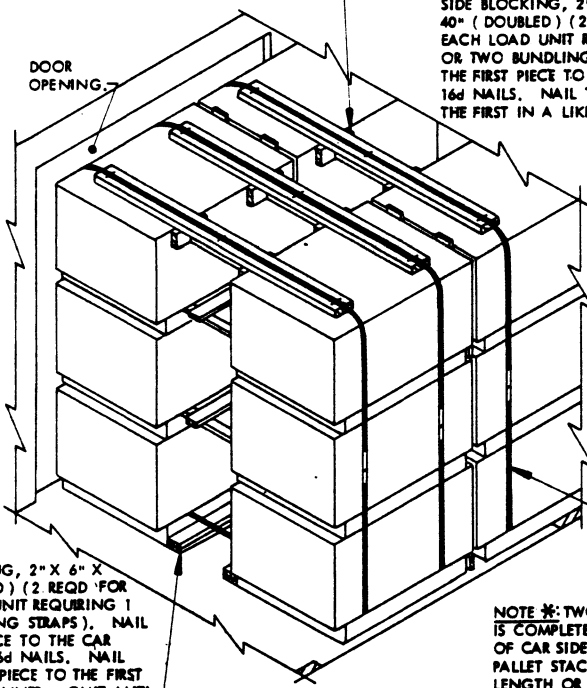

DOOR OPENING.

BEARING PIECE, 2" X 6" X 12" (2 REQD.). NAIL TO SPACER PIECE W/3 12d NAILS.

SPACER PIECE, 2" X 6" BY A LENGTH TO SUIT (1 REQD.).

BUNDLING STRAP, 1-1/4" X .031" OR .035" BY A LENGTH TO SUIT STEEL STRAPPING (AS REQD.). STAPLE TO SPACER ASSEMBLY W/3 STAPLES. SEE "NOTE #\*" BELOW.

FABRICATE TO FIT

STRAPPING BOARD, 2" X 6" BY CAR WIDTH MINUS 11" (1 REQD.). NAIL TO 2" X 6" X 12" W/2-12d NAILS AT EACH JOINT.

SPACER ASSEMBLY

SIDE BLOCKING, 2" X 6" X 48" (DOUBLED) (2 REQD FOR EACH LOAD UNIT REQUIRING 1 OR 2 BUNDLING STRAPS). NAIL THE FIRST PIECE TO THE CAR FLOOR W/5-16d NAILS. NAIL THE SECOND PIECE TO THE FIRST IN A LIKE MANNER. OMIT ANTI-SWAY BRACE (5) AT FLOOR LEVEL.

**ALTERNATIVE DOORWAY PROTECTION F**

NOTE #\*: TWO (2) BUNDLING STRAPS ARE REQUIRED FOR EACH PALLET STACK AND/OR LOAD UNIT WHICH IS COMPLETELY WITHIN THE DOORWAY AREA OR WHICH IS NOT RETAINED BY AT LEAST SIX INCHES (6") OF CAR SIDEWALL ON BOTH SIDES OF THE CAR. ONE (1) BUNDLING STRAP IS REQUIRED FOR EACH PALLET STACK AND/OR LOAD UNIT WHICH IS RETAINED BY FROM 6" TO ONE-HALF THE PALLET/LOAD UNIT LENGTH OR WIDTH.



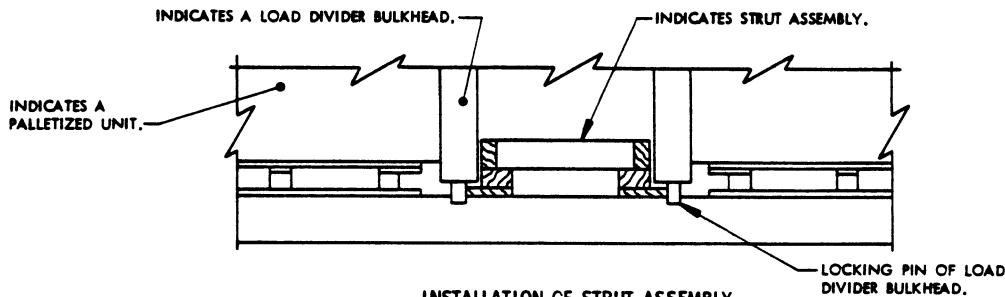

**INSTALLATION OF STRUT ASSEMBLY**

THIS VIEW SHOWS THE STRUT ASSEMBLY INSTALLED BETWEEN THE LOAD DIVIDER BULKHEADS. NOTE THE 1/2" TO 3/4" (TOTAL) SPACE INTENTIONALLY PROVIDED BETWEEN THE ASSEMBLY AND THE BULKHEADS.

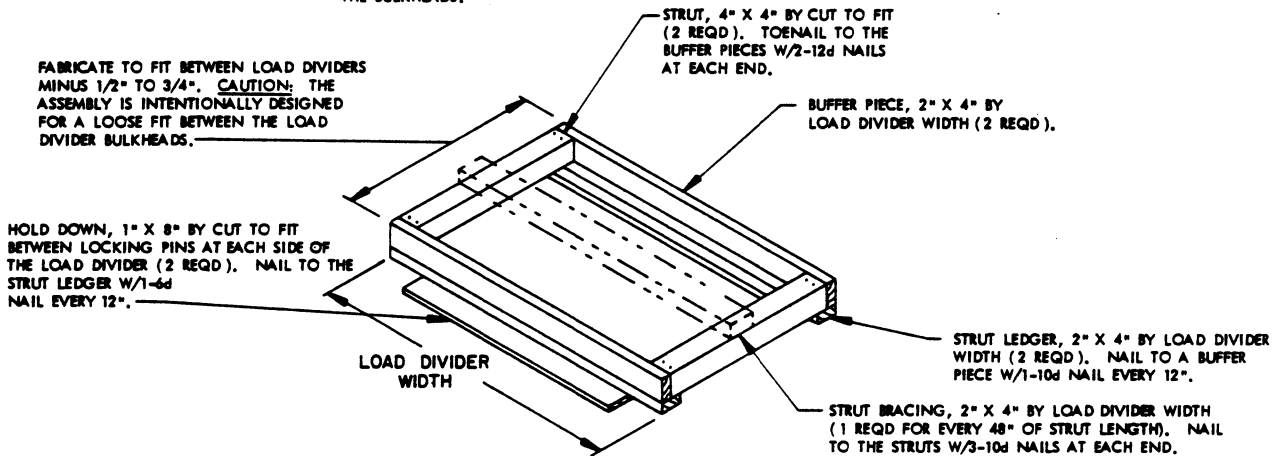

**STRUT ASSEMBLY FOR 2-PIECE BULKHEADS**

A STRUT ASSEMBLY IS REQUIRED WHEN THE LOAD BEHIND EITHER LOAD DIVIDER BULKHEAD EXCEEDS 50,000 POUNDS OF CLASS A OR CLASS B EXPLOSIVES. A STRUT ASSEMBLY IS NOT REQUIRED FOR LOADS OF CLASS C EXPLOSIVES, REGARDLESS OF THE WEIGHT OF THE LOAD. NOTE: TWO (2) ASSEMBLIES AS SHOWN ARE REQUIRED FOR A 2-PIECE BULKHEAD IF NOT LATERALLY ALIGNED. SEE "NOTE [ ]" BELOW.

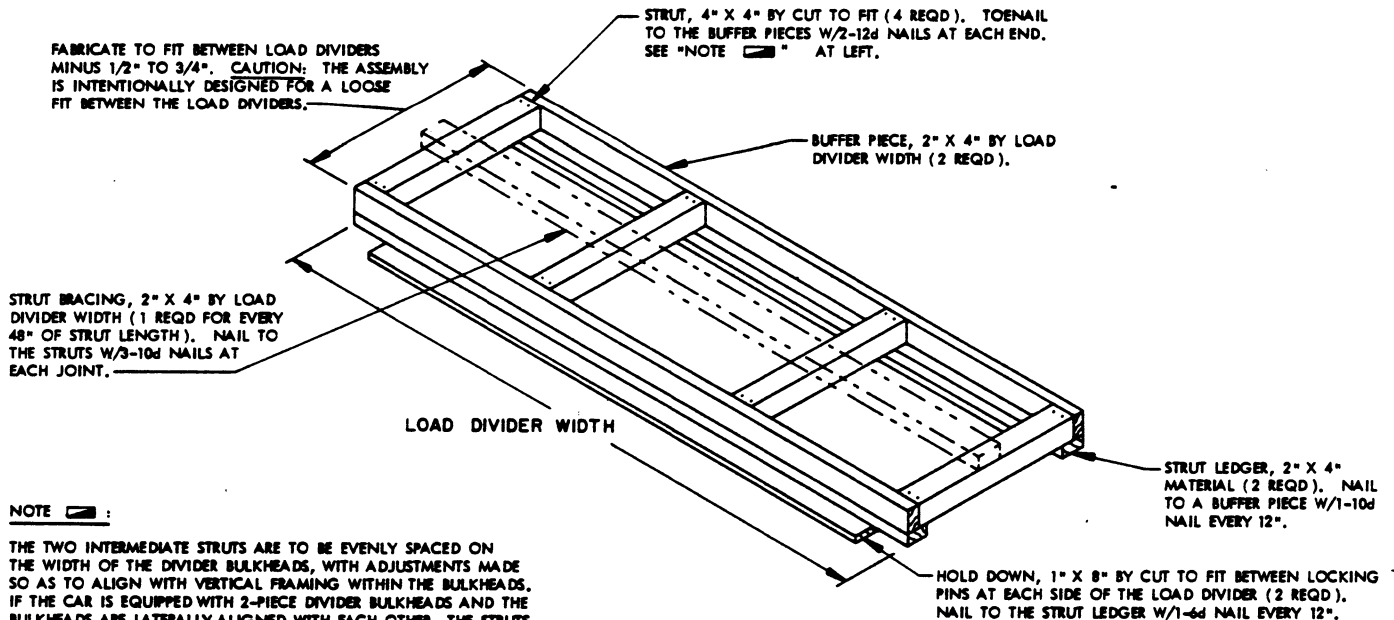

**NOTE [ ] :**

THE TWO INTERMEDIATE STRUTS ARE TO BE EVENLY SPACED ON THE WIDTH OF THE DIVIDER BULKHEADS, WITH ADJUSTMENTS MADE SO AS TO ALIGN WITH VERTICAL FRAMING WITHIN THE BULKHEADS. IF THE CAR IS EQUIPPED WITH 2-PIECE DIVIDER BULKHEADS AND THE BULKHEADS ARE LATERALLY ALIGNED WITH EACH OTHER, THE STRUTS SHOULD BE ALIGNED WITH THE EDGES OF THE BULKHEADS; IF THE BULKHEADS ARE NOT ALIGNED, THE "STRUT ASSEMBLY FOR 2-PIECE BULKHEADS" MUST BE USED. SEE THE DETAIL ABOVE.

**STRUT ASSEMBLY FOR 1-PIECE BULKHEADS**

A STRUT ASSEMBLY IS REQUIRED WHEN THE LOAD BEHIND EITHER LOAD DIVIDER BULKHEAD EXCEEDS 50,000 POUNDS OF CLASS A OR CLASS B EXPLOSIVES. A STRUT ASSEMBLY IS NOT REQUIRED FOR LOADS OF CLASS C EXPLOSIVES, REGARDLESS OF THE WEIGHT OF THE LOAD.

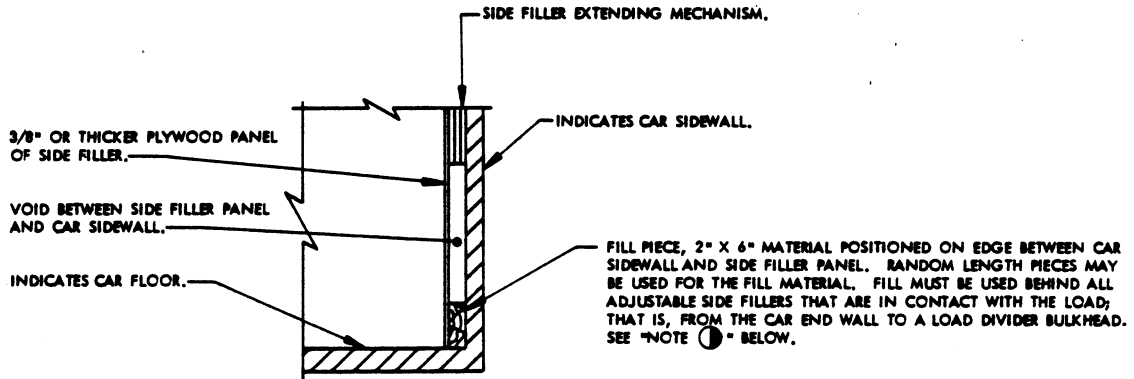

**TYPICAL TYPE A**

THIS VIEW SHOWS THE INSTALLATION OF A "FILL PIECE" IN A CAR EQUIPPED WITH A STANDARD ADJUSTABLE SIDE FILLER.

**NOTE ①:**

NAILING OF "FILL PIECES" IS NOT REQUIRED EXCEPT THAT EACH "FILL PIECE" LOCATED NEAREST THE DOOR OPENINGS OF THE CAR WILL BE SECURED AGAINST LONGITUDINAL MOVEMENT W/1-6d NAIL DRIVEN THROUGH THE SIDE FILLER PANEL AND INTO THE "FILL PIECE".

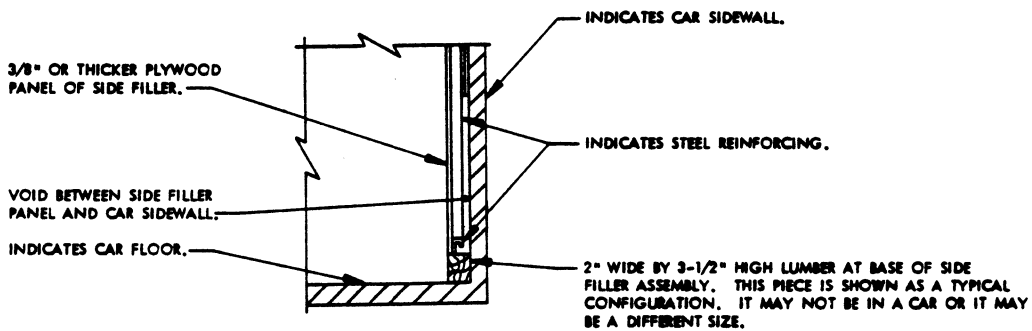

**TYPICAL TYPE B**

THIS VIEW SHOWS A TYPICAL SECTION OF A CAR EQUIPPED WITH HEAVY DUTY, STEEL REINFORCED, ADJUSTABLE SIDE FILLERS. A "FILL PIECE", AS SHOWN IN THE "TYPICAL TYPE A" DETAIL ABOVE, IS NOT REQUIRED IN CARS SO EQUIPPED.