

APPENDIX 24

UNITIZING PROCEDURES FOR PROPELLING CHARGES PACKED IN CYLINDRICAL METAL CONTAINERS ON 4-WAY ENTRY PALLETS

PA107 SERIES CONTAINER

<u>ITEM</u>	<u>INDEX</u>	<u>PAGE (S)</u>
GENERAL NOTES -----		2
UNIT DETAIL AND PALLET DETAIL -----		4
DUNNAGE DETAILS -----		5
FILLERS AND INSTALLATION PROCEDURES FOR OMITTED CONTAINERS -----		6,7

PALLET UNIT DATA						
ITEMS INCLUDED		HAZARD CLASSIFICATION ①				WEIGHT (LBS)
NSN	DODIC	DOT CLASS	CG CLASS	QD CLASS	COMP GROUP	
UN-ASSIGNED						1,540

NOTICE: THIS APPENDIX CANNOT STAND ALONE BUT MUST BE USED IN CONJUNCTION WITH THE BASIC UNITIZATION PROCEDURES DRAWING 19-48-4042A-20PM1001.

① HAZARD CLASSIFICATION DATA CONTAINED IN THE ABOVE CHART IS FOR GUIDANCE AND INFORMATIONAL PURPOSES ONLY. VERIFICATION OF THE SPECIFIED DATA SHOULD BE MADE BY CONSULTING THE MOST RECENT JOINT HAZARD CLASSIFICATION SYSTEM LISTING OR OTHER APPROVED LISTING (S).

REVISIONS				DRAWN BY dh	PROJ ENG LAF/NRF
				CHECKER GIBS	LOG ENG OFFICE W. Ernst
				APPROVED BY ORDER OF COMMANDING GENERAL, U.S. ARMY AMMUNITION CENTER AND SCHOOL MATERIAL COMMAND <i>W. Martin</i> <i>B. J. ...</i>	
				SHCAR - ESK AMSC - TMO <i>William J. Ernst</i> U.S. ARMY AMMUNITION CENTER AND SCHOOL	
				U.S. ARMY AMC DRAWING JULY 1987	
				CLASS	DIVISION
				19	48
				DRAWING	FILE
				4042A/ 24	20PM 1001

DO NOT SCALE

GENERAL NOTES

- A. THIS APPENDIX CANNOT STAND ALONE BUT MUST BE IN CONJUNCTION WITH THE BASIC UNITIZING PROCEDURES DRAWING 19-48-4042A-20PM1001. TO PRODUCE AN APPROVED UNIT LOAD, ALL PERTINENT PROCEDURES, SPECIFICATIONS AND CRITERIA SET FORTH WITHIN THE BASIC DRAWING WILL APPLY TO THE PROCEDURES DELINEATED IN THIS APPENDIX. ANY EXCEPTIONS TO THE BASIC PROCEDURES ARE SPECIFIED IN THIS APPENDIX.
- B. DIMENSIONS, CUBE AND WEIGHT OF A PALLET UNIT WILL VARY SLIGHTLY DEPENDING UPON THE ACTUAL DIMENSIONS OF THE CONTAINER, WEIGHT OF THE SPECIFIC ITEM, AND METHOD OF UNITIZATION.
- C. FOR OUTLOADING AND STORAGE OF THE ITEMS COVERED BY THIS APPENDIX, REFER TO DA PAM 75-5 OR CONTACT U.S. ARMY DEFENSE AMMUNITION CENTER AND SCHOOL, ATTN: SMCAC-DEO, SAVANNA, IL 61074-9639.
- D. FOR METHOD OF SECURING A STRAP CUTTER TO THE PALLET UNIT, SEE DARCOM DRAWING 19-48-4127-20P1000.
- E. IF ITEMS COVERED HEREIN ARE UNITIZED PRIOR TO ISSUANCE OF THIS APPENDIX, THE CONTAINERS NEED NOT BE REUNITIZED SOLELY TO CONFORM TO THIS APPENDIX.
- F. THE UNITIZATION PROCEDURES DEPICTED HEREIN MAY ALSO BE USED FOR UNITIZING PROPELLING CHARGES WHEN IDENTIFIED BY DIFFERENT NATIONAL STOCK NUMBERS (NSN) THAN THOSE SHOWN ON THE COVER PAGE, PROVIDED THE ITEM IS PACKED IN THE PA107 SERIES CONTAINER. THE EXPLOSIVE CLASSIFICATION OF OTHER ITEMS MAY BE DIFFERENT THAN THOSE SHOWN.
- G. FOR DETAILS OF THE PA107 SERIES CONTAINER, SEE U.S. ARMY ARMAMENT RESEARCH AND DEVELOPMENT CENTER DRAWING NO. 9390460.

CONTAINER DIMENSIONS ————— 35-1/4" LONG X 7-1/8" WIDE X 7-1/8" HIGH.
CONTAINER CUBE ————— 1.04 CUBIC FEET.
CONTAINER WEIGHT (WITH CHARGE) - 39 LBS (APPROX).
- H. IF DEEMED MORE ECONOMICAL FOR SHIPPING AND STORAGE BY THE RESPONSIBLE COMMAND, THE UNIT DEPICTED ON THE FOLLOWING PAGES MAY BE DECREASED BY ONE COMPLETE LAYER OF CONTAINERS. FOR FURTHER UNITIZATION GUIDANCE, SEE SPECIAL NOTES ON PAGE 4.

THIS PAGE HAS BEEN INTENTIONALLY LEFT BLANK.

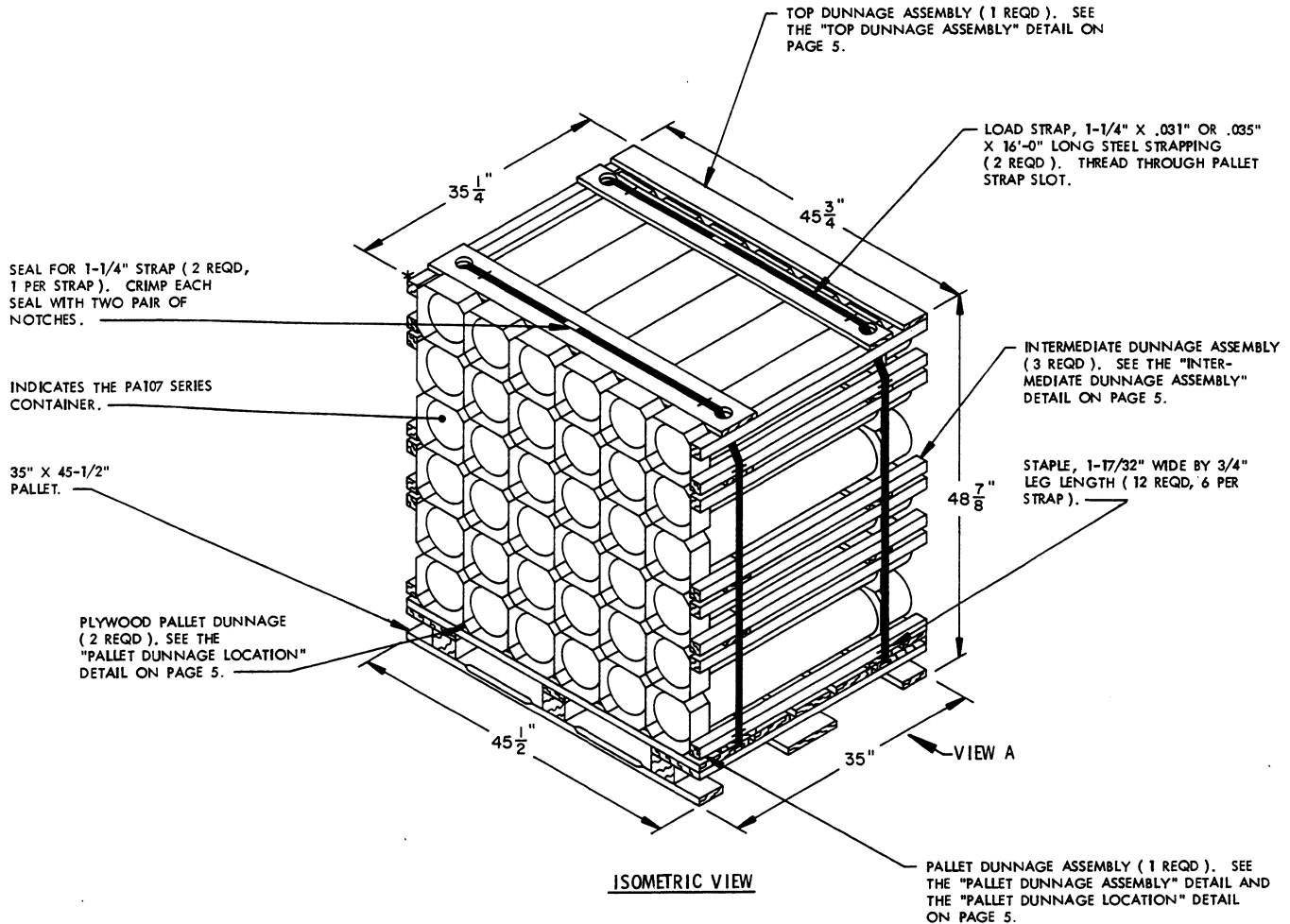

SPECIAL NOTES:

1. WHEN THE UNIT LOAD DEPICTED ABOVE IS TO BE USED FOR UNITIZING MARINE CORPS AMMUNITION, ONE LAYER OF CONTAINERS MUST BE OMITTED, THE UPPER-MOST "INTERMEDIATE DUNNAGE ASSEMBLY" MUST BE OMITTED, AND THE LOAD STRAP LENGTHS MUST BE DECREASED TO 14'-9". THIS WILL RESULT IN AN OVERALL UNIT HEIGHT OF 41'-3/4", A GROSS UNIT WEIGHT OF 1,407 POUNDS, AND A UNIT CUBE OF 39.0 CUBIC FEET.
2. THE UNIT LOAD DEPICTED ABOVE MAY ALSO BE REDUCED BY ONE OR TWO LAYERS OF CONTAINERS, AS DESCRIBED IN SPECIAL NOTE 1, WHEN BEING SHIPPED BY MILVAN OR COMMERCIAL INTERMODAL FREIGHT CONTAINER. THE DETERMINATION TO REDUCE THE LOAD BY A LAYER WILL BE MADE BY THE RESPONSIBLE COMMAND AND WILL BE BASED UPON ECONOMICS OF TRANSPORTATION AND HANDLING.
3. DIMENSIONS GIVEN FOR DUNNAGE PIECES OR DUNNAGE ASSEMBLIES WILL BE FIELD CHECKED PRIOR TO THEIR ASSEMBLY TO THE PALLET UNIT. CONTAINERS MUST FIT SNUGLY IN THE DUNNAGE ASSEMBLIES. ALSO, DUE TO THE VARIATION OF CONTAINER DIMENSIONS, ADJUSTMENTS MAY BE REQUIRED AS TO THE LOCATION OF CERTAIN PIECES OF DUNNAGE IN A DUNNAGE ASSEMBLY.
4. ALTHOUGH THE PROPELLING CHARGE CONTAINERS DEPICTED IN THE UNIT LOAD ABOVE ARE CONSTRUCTED WITH INTERLOCKING DEVICES, THE INTERLOCKS WILL NOT FUNCTION PROPERLY UNLESS THE CONTAINERS ARE POSITIONED SO THAT THE "PINS" OF THE INTERLOCKS ARE IN AN UPRIGHT ORIENTATION. THIS ORIENTATION WILL PRECLUDE INTERFERENCE OF THE "PINS" AND THE PLYWOOD PALLET DUNNAGE AND WILL AID IN THE PREVENTION OF CONTAINER MOVEMENT, BOTH Laterally AND LONGITUDINALLY, DURING SHIPMENT OF THE UNIT LOAD.

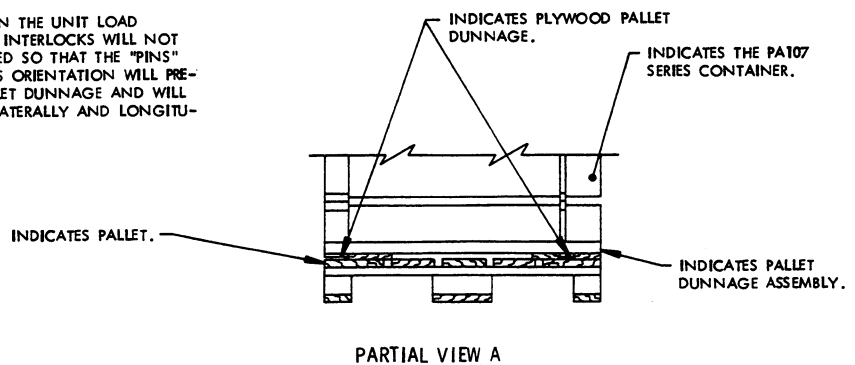

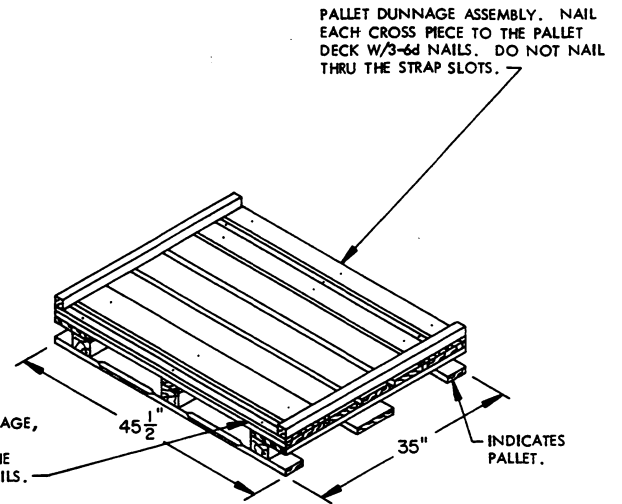
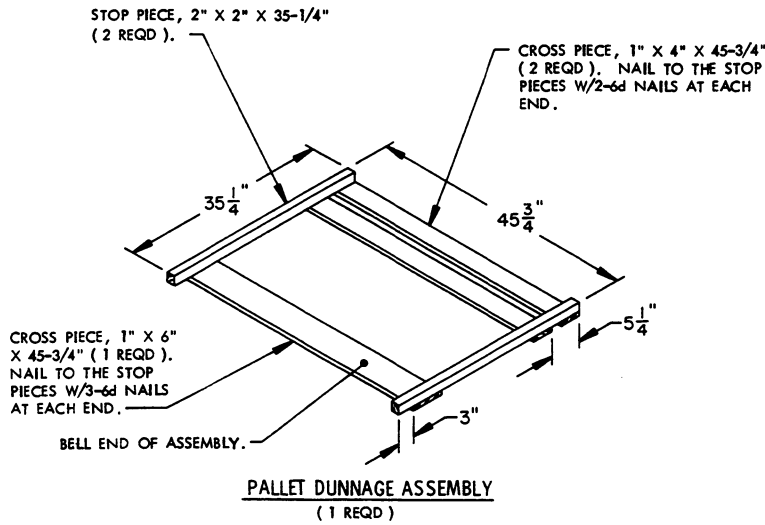

PALLET DUNNAGE LOCATION

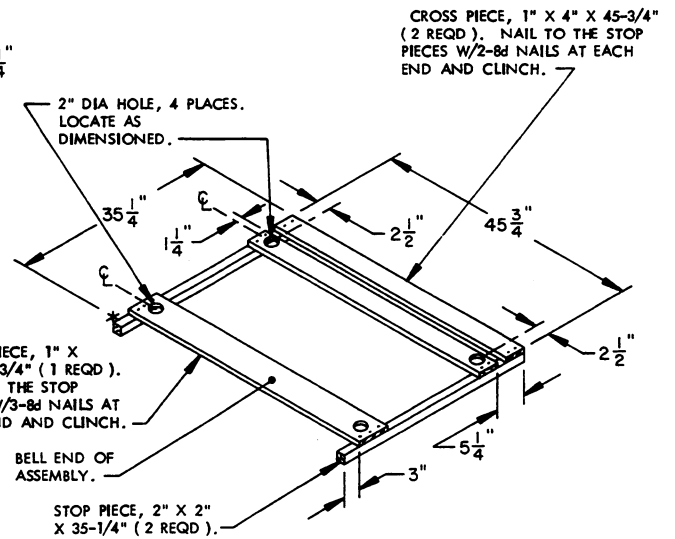
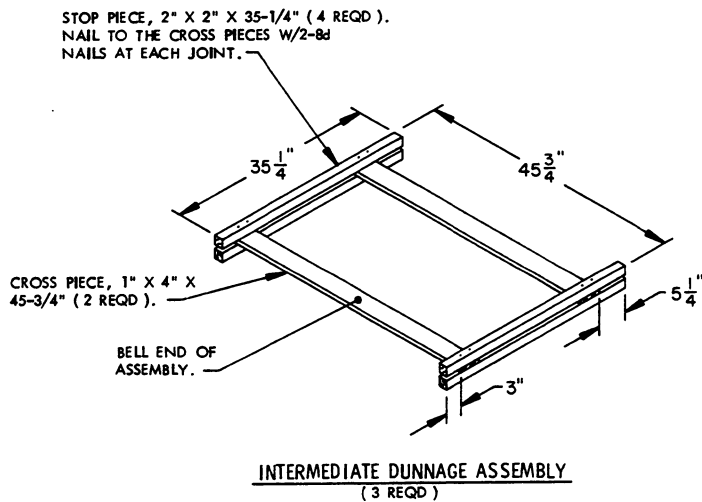

TOP DUNNAGE ASSEMBLY
(1 REQD)

BILL OF MATERIAL			
LUMBER	NO. REQD	LINEAR FEET	BOARD FEET
1" X 4" X 45-3/4"	10	38.13	12.71
1" X 6" X 45-3/4"	2	7.63	3.81
2" X 2" X 35-1/4"	16	47.00	15.67
NAILS		NO. REQD	POUNDS
4d (1-1/2")	6		0.02
6d (2")	23		0.14
8d (2-1/2")	64		0.67
PALLET, 35" X 45-1/2"		1 REQD	65 LBS
STEEL STRAPPING, 1-1/4" X .031" OR .035"-32.00'		2 REQD	4.57 LBS
SEAL FOR 1-1/4" STRAPPING		2 REQD	NIL
STAPLE, 1-17/32" X 3/4"		12 REQD	NIL
PLYWOOD, 3/8"		0.63 SQ FT REQD	0.65 LBS

UNIT DATA

	WEIGHT
CUBE	45.6 CUBIC FEET (APPROX)
CONTAINER, PA107 SERIES - 36 EACH @ 39 LBS	1,404 LBS (APPROX)
DUNNAGE	71 LBS
PALLET	65 LBS
TOTAL WEIGHT	1,540 LBS (APPROX)

DUNNAGE DETAILS

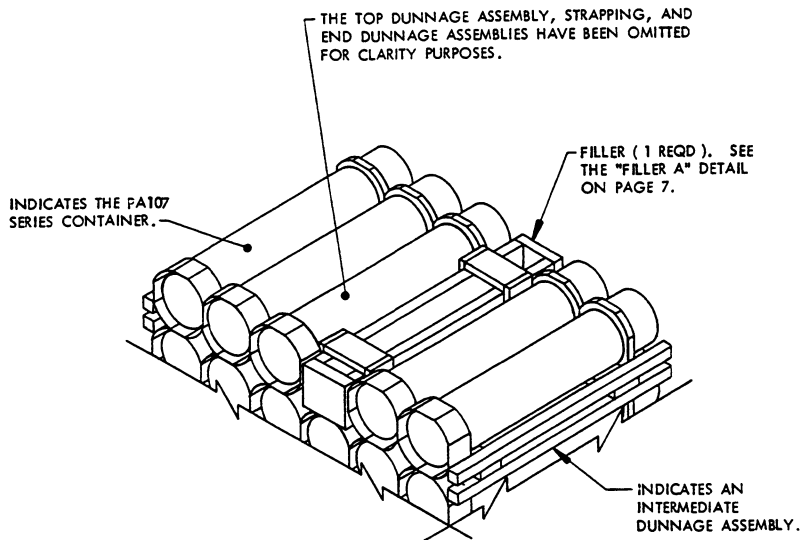

DETAIL A

THIS DETAIL DEPICTS PROCEDURES TO BE USED WHEN A STANDARD PALLET UNIT MINUS ONE CONTAINER IS TO BE UNITIZED. THE FILLER ASSEMBLY DEPICTED MUST BE INSTALLED IN THE MIDDLE OF THE TOP LAYER OF THE PALLET UNIT.

SPECIAL NOTES:

1. WHEN SIX CONTAINERS ARE TO BE OMITTED FROM A PALLET UNIT A COMPLETE LAYER OF CONTAINERS MUST BE OMITTED. WHEN FIVE CONTAINERS ARE TO BE OMITTED FROM A PALLET UNIT, A COMBINATION OF FILLER ASSEMBLIES DEPICTED ON PAGE 7 MUST BE USED. WHEN FOUR OR LESS CONTAINERS ARE TO BE OMITTED FROM A PALLET UNIT, A COMBINATION OR ONE OF THE FILLER ASSEMBLIES DEPICTED ON PAGE 7 MAY BE USED. ALL FILLER ASSEMBLIES MUST BE INSTALLED IN THE MIDDLE OF THE TOP LAYER OR LAYERS OF A PALLET UNIT.
2. THE OVERALL HEIGHT OF THE FILLER ASSEMBLIES DEPICTED ON PAGE 7 MUST BE REDUCED FROM 7" TO 6-1/4" WHEN INSTALLED BETWEEN A TOP DUNNAGE ASSEMBLY AND AN INTERMEDIATE DUNNAGE ASSEMBLY OR BETWEEN ANOTHER FILLER ASSEMBLY AND AN INTERMEDIATE DUNNAGE ASSEMBLY.

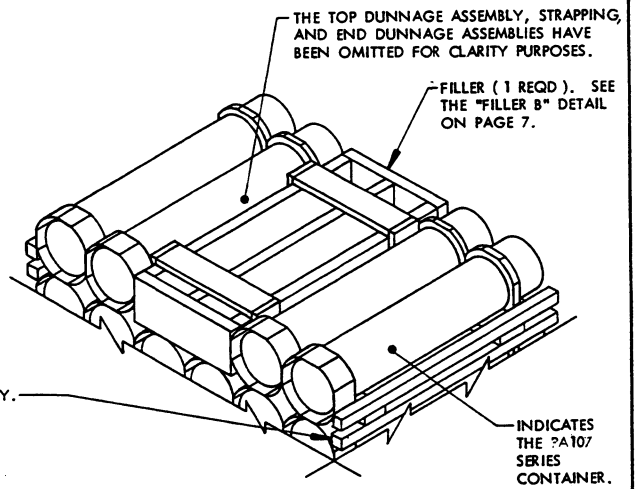

DETAIL B

THIS DETAIL DEPICTS PROCEDURES TO BE USED WHEN A STANDARD PALLET UNIT MINUS TWO CONTAINERS IS TO BE UNITIZED. THE FILLER ASSEMBLY DEPICTED MUST BE INSTALLED IN THE MIDDLE OF THE TOP LAYER OF THE PALLET UNIT.

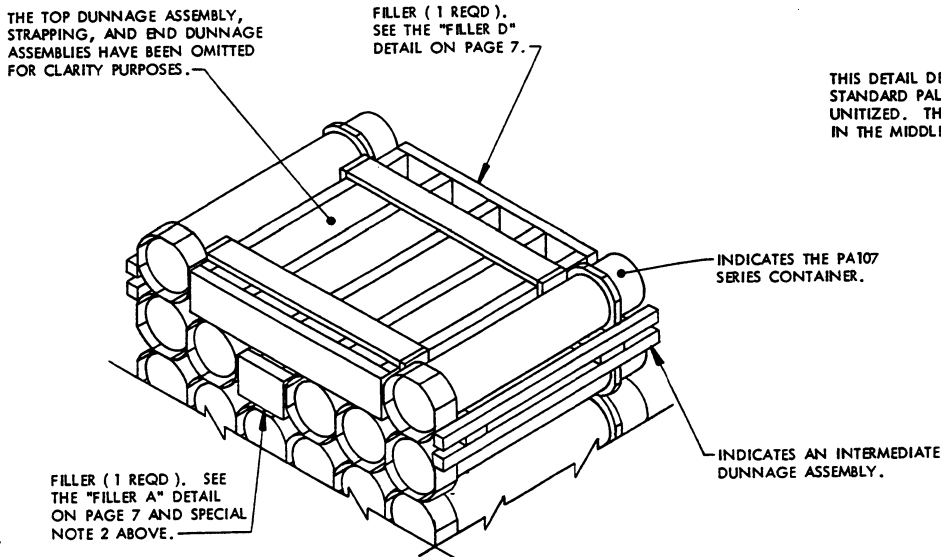

DETAIL C

THIS DETAIL DEPICTS PROCEDURES TO BE USED WHEN A STANDARD PALLET UNIT MINUS FIVE CONTAINERS IS TO BE UNITIZED. THE FILLER ASSEMBLIES DEPICTED MUST BE INSTALLED IN THE MIDDLE OF THE TOP LAYERS OF THE PALLET UNIT.

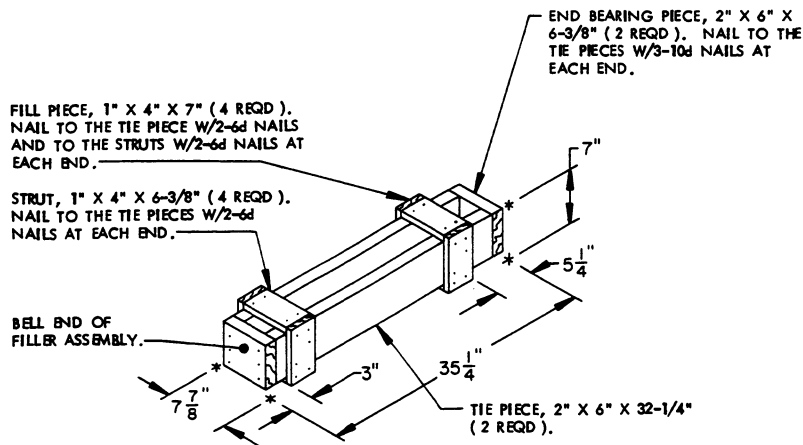

FILLER A

THIS FILLER ASSEMBLY IS TO BE USED WHEN ONE CONTAINER IS TO BE OMITTED FROM A PALLET UNIT, OR IN COMBINATION WITH OTHER FILLER ASSEMBLIES.

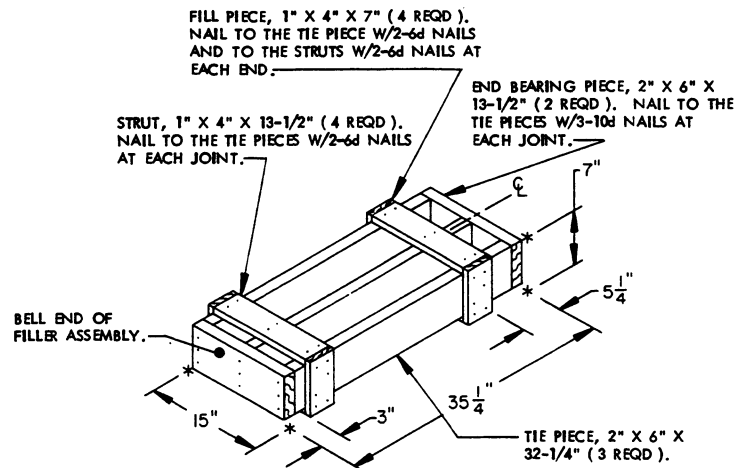

FILLER B

THIS FILLER ASSEMBLY IS TO BE USED WHEN TWO CONTAINERS ARE TO BE OMITTED FROM A PALLET UNIT, OR IN COMBINATION WITH OTHER FILLER ASSEMBLIES.

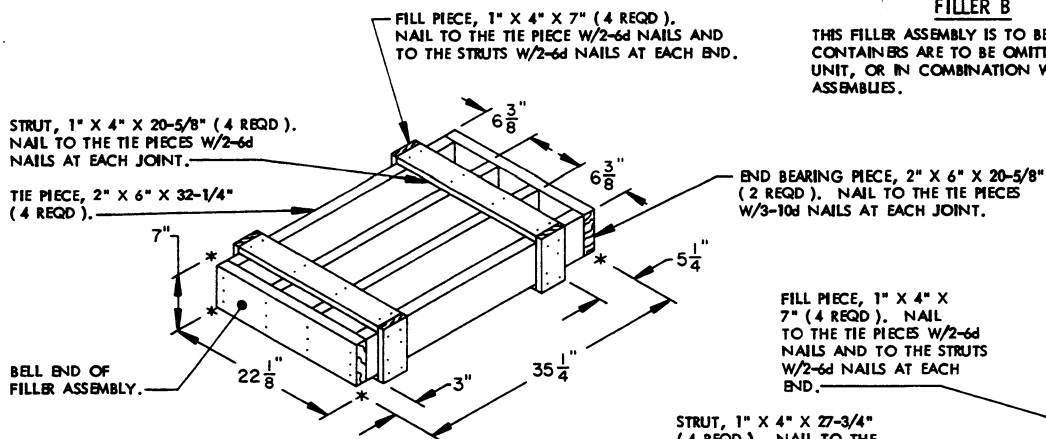

FILLER C

THIS FILLER ASSEMBLY IS TO BE USED WHEN THREE CONTAINERS ARE TO BE OMITTED FROM A PALLET UNIT, OR IN COMBINATION WITH OTHER FILLER ASSEMBLIES.

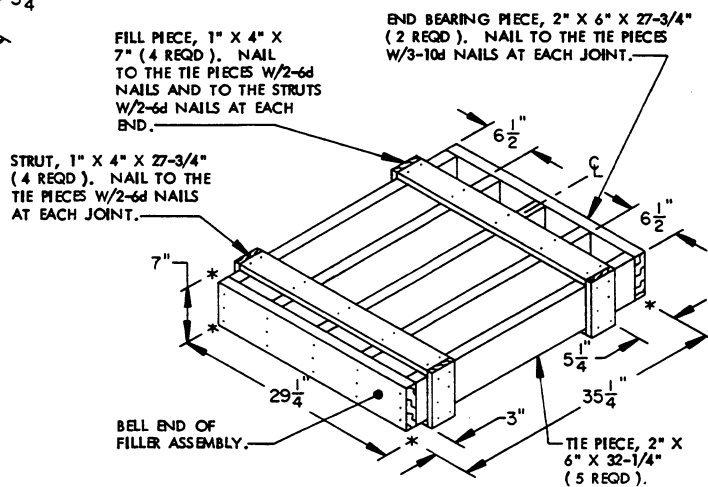

FILLER D

THIS FILLER ASSEMBLY IS TO BE USED WHEN FOUR CONTAINERS ARE TO BE OMITTED FROM A PALLET UNIT, OR IN COMBINATION WITH OTHER FILLER ASSEMBLIES.

