



STORAGE OF BULK PROPELLANTS IN SMOKELESS POWDER MAGAZINES WITH AND WITHOUT CENTER POSTS

INDEX

<u>ITEM</u>	<u>PAGE (+)</u>
GENERAL NOTES	2
POWDER, PROPELLANT, 50 POUNDS PER WOODEN BOX, #18	13
POWDER, PROPELLANT, #17 WOODEN BOX, (SMALL MOUTH)	13
POWDER, PROPELLANT, #2 AND MK VIII STEEL BOX, (VERTICAL STORAGE)	13
POWDER, PROPELLANT, #2 AND MK VIII STEEL BOX, (ANGULAR STORAGE)	13
POWDER, PROPELLANT, #24 METAL-LINED WOODEN BOX (ANGULAR STORAGE)	13
POWDER, PROPELLANT, #24 WOODEN BOX (VERTICAL STORAGE)	13
POWDER, PROPELLANT, #17 WOODEN BOX (LARGE MOUTH)	13

+ Page reference is for tabular data. Columns 3 & 4 of tabular data refers to proper plan, elevation, and details for the item.

CAUTION

General Notes, Page 2, will be thoroughly read prior to storage operations.

STORAGE OF BULK PROPELLANTS IN SMOKELESS POWDER MAGAZINES WITH AND WITHOUT CENTER POSTS			
DESIGNER	CHECKER	ENGINEER	APPROVED
RAS		CRJ/	<i>Joseph E. Callis</i> CAPTAIN, ORDNANCE CORPS, U.S.A.
25			<i>James D. Burke</i> CAPTAIN, ORDNANCE CORPS, U.S.A.
REVISIONS			<i>James E. [Signature]</i> CAPTAIN, ORDNANCE CORPS, U.S.A.
			ORDNANCE CORPS U.S.A.
			22 April 1958
			CLASS DIVISION DRAWING FILE
			19 48 4022 6-7A1000

GENERAL NOTES

- 1.-VERTICAL AND ANGULAR POSITIONING OF BOXES WILL BE IN ACCORDANCE WITH INSTRUCTIONS CONTAINED IN LETTER FILE ORDFA-T, DATED 9 APRIL, 1947.
SUBJECT: "INSPECTION & STORAGE OF BULK PROPELLANTS"
- 2.-IN THOSE INSTANCES WHEREIN THE INSIDE DIMENSIONS OF MAGAZINES ARE DIFFERENT FROM THOSE SHOWN IN TYPICAL FLOOR PLANS, PAGE 3, OR WHEREIN VARIATIONS IN CONTAINER DIMENSIONS OCCUR, THE NUMBER OF BOXES PER STACK AND/OR THE NUMBER OF STACKS PER MAGAZINE MAY BE ADJUSTED TO PERMIT MINIMUM AISLE WIDTHS, AND CLEARANCES OR MAXIMUM STORAGE.
3. POUNDS OF EXPLOSIVES PER MAGAZINE, SHOWN IN TABULAR DATA, PAGE 10, APPLY TO CLASS 2 PROPELLANTS, ONLY.

MATERIAL SPECIFICATIONS*

LUMBER: SEE PARAGRAPH 5400, ORDM 3-4, VOLUME 2,
NAILS: COMMON, CEMENT COATED, FED. SPEC. FF-N-105
ALTERNATE-ANNULAR-RING TYPE NAILS OF SAME SIZE

*NOTE-USE LATEST CHANGES TO ALL FED. SPECIFICATIONS

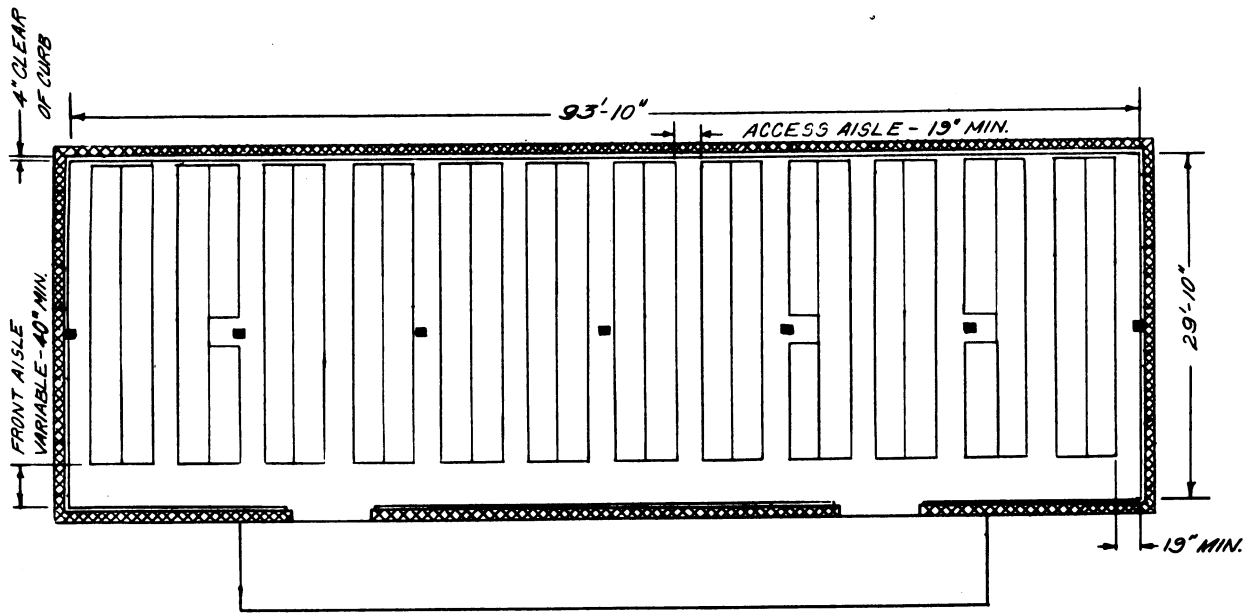

TYPICAL FLOOR PLAN-SMOKELESS POWDER MAGAZINE
WITH CENTER POSTS

NOTE: PORTIONS OF STACKS WILL BE OMITTED TO CLEAR CENTER POSTS

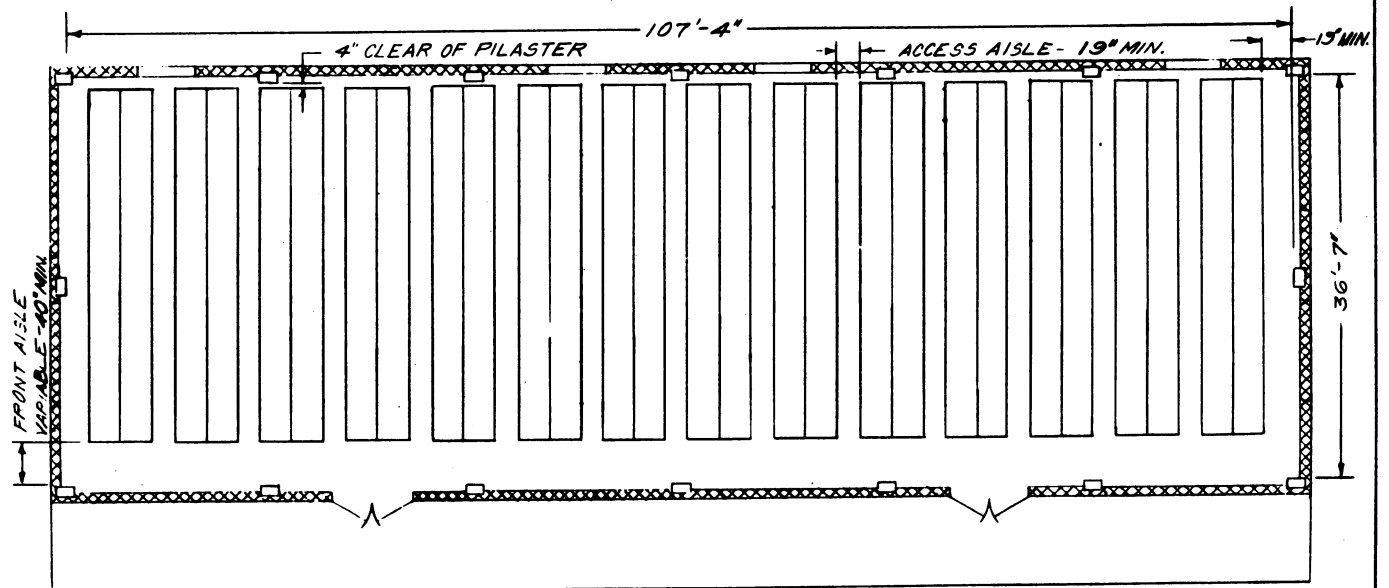

TYPICAL FLOOR PLAN-SMOKELESS POWDER MAGAZINE
w/o CENTER POSTS

4" x 4" x 27" (DUNNAGE
DETAIL ①)

2" x 4" x 27" (DUNNAGE
DETAIL ②)

STACK LENGTH IN MAGAZINES W/CENTER POSTS

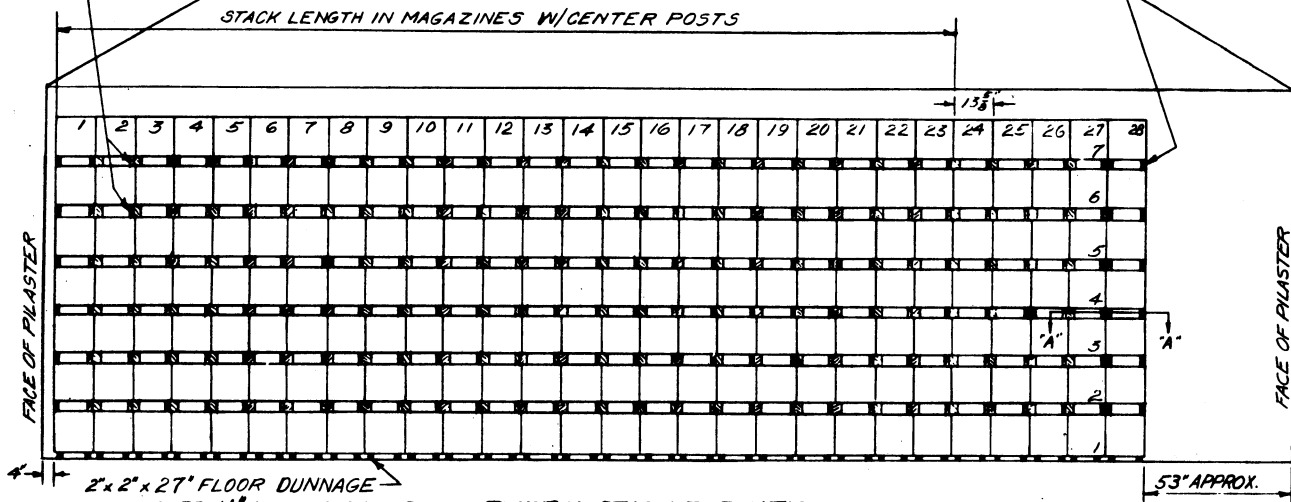

2" x 2" x 27" FLOOR DUNNAGE -
POSITIONED 1/2" FROM EACH END
OF BOX LENGTH PARALLEL TO
BACK WALL OF MAGAZINE

TYPICAL STACK ELEVATION
QUANTITY PER DOUBLE STACK

SMKLS POWDER MAGAZINE W/O CENTER POSTS = 392 BOXES
SMKLS POWDER MAGAZINE WITH CENTER POSTS = 322 BOXES

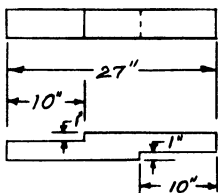

DUNNAGE DETAIL ① - 4" x 4" MAT'L.

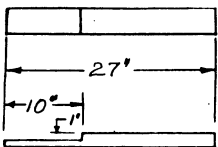

DUNNAGE DETAIL ② - 2" x 4" MAT'L.

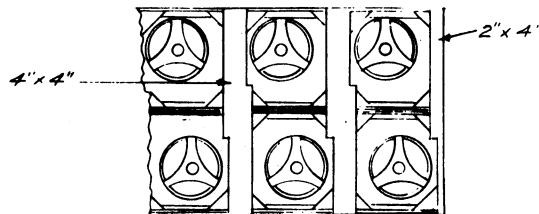

PARTIAL STACK DETAIL - VIEW "A-A"

NOTE:
LIDS ARE PLACED ADJACENT TO LATERAL AISLES.
NOTCHES IN DUNNAGE ARE PLACED TO PERMIT
REMOVAL OF LID.

NOTE:
DUNNAGE SHOWN IN DETAILS ① & ② MAY BE FABRICATED
FROM 1" x 4" AND 2" x 4" LUMBER.

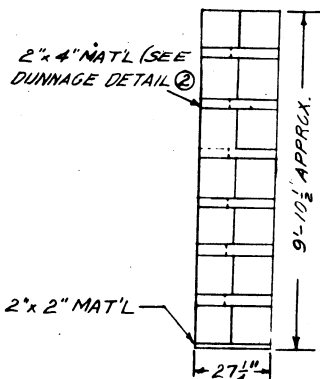

DETAIL - END OF STACK

POWDER, PROPELLANT - 50 LBS. PER WDN BOX, M18
BOX SIZE - 13 5/8" x 13 5/8" x 13 5/8"

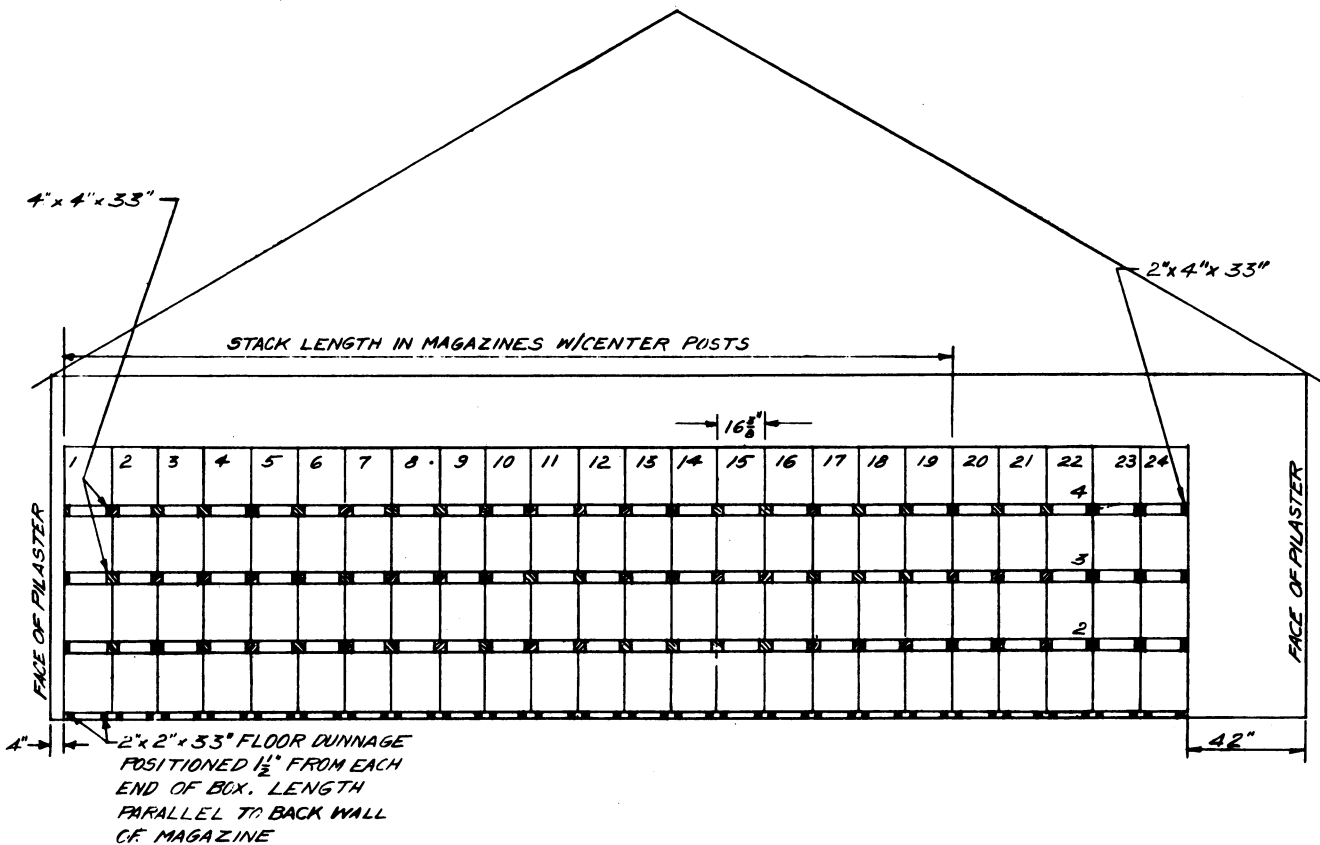

TYPICAL STACK ELEVATION
QUANTITY PER DOUBLE STACK
 SMKLS POWDER MAGAZINE W/O CENTER POSTS = 192 BOXES
 SMKLS POWDER MAGAZINE WITH CENTER POSTS = 152 BOXES

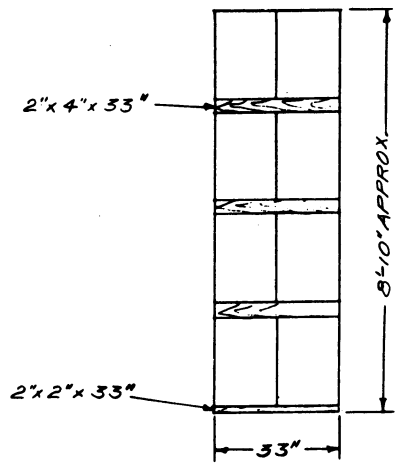

DETAIL - END OF STACK

POWDER PROPELLANT PACKED IN MIT WOODEN BOX
 BOX SIZE - 16 3/8" L x 16 3/8" W x 23 3/8" H
 (SMALL MOUTH)

NOTE *

CNTRS DEFORMED AS A RESULT OF REQD AIR TESTING MAY BE UNITIZED AS SHOWN WITH $\frac{3}{8}$ " OR $\frac{1}{2}$ " x .020" STEEL STRAPPING, GALV, FOR INCREASED STABILITY.

4" x 4" x 32"
(SEE DETAIL)

2" x 4" x 32"

STACK LENGTH IN MAGAZINES W/CENTER POSTS

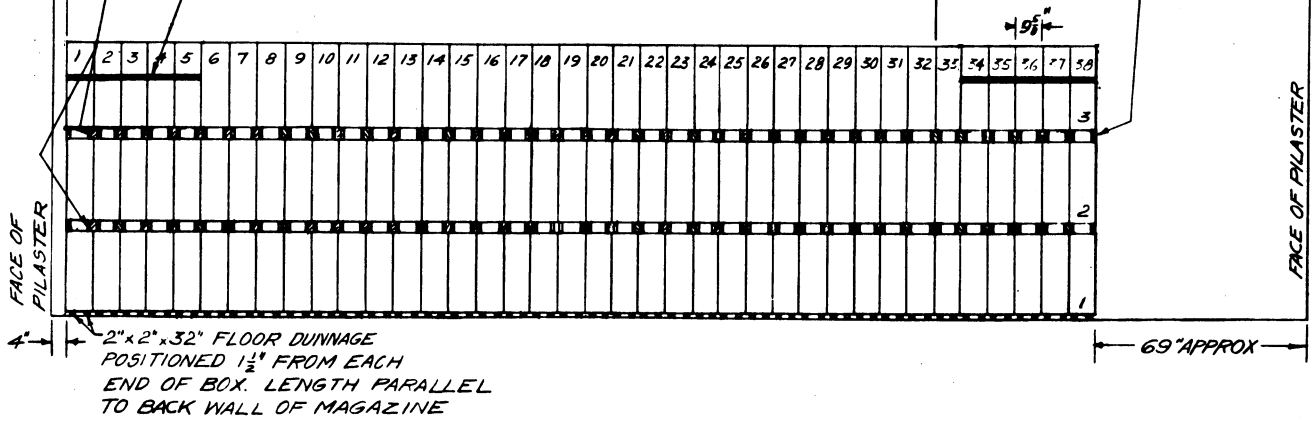

TYPICAL STACK ELEVATION

QUANTITY PER DOUBLE STACK

5M KLS. POWDER MAGAZINE W/O CENTER POSTS - 228 BOXES

5M KLS. POWDER MAGAZINE WITH CENTER POSTS - 192 BOXES

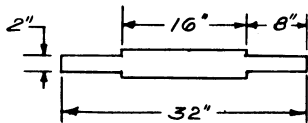

TOP VIEW



SIDE VIEW



END VIEW

DETAIL - 4" x 4" DUNNAGE

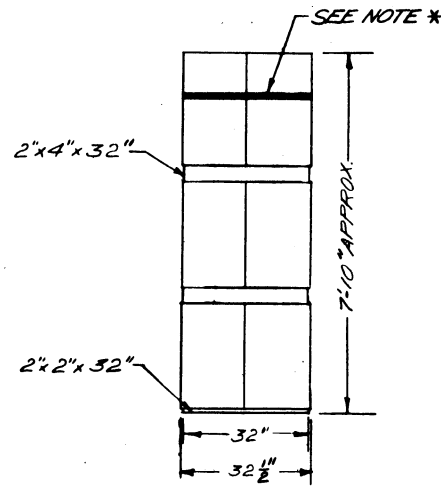

DETAIL - END OF STACK

POWDER PROPELLANT PACKED IN BOX STEEL M2 & MK VII
 BOX SIZE - $16\frac{1}{4}$ " L x $9\frac{5}{8}$ " W x $28\frac{1}{8}$ " H.
 (VERTICAL STORAGE)

NOTE *
 CNTRS DEFORMED AS A RESULT OF REQUIRED AIR TESTING MAY BE UNITIZED AS SHOWN WITH $\frac{3}{8}$ " OR $\frac{1}{2}$ " x .020" STEEL STRAPPING, GALV, FOR INCREASED STABILITY.

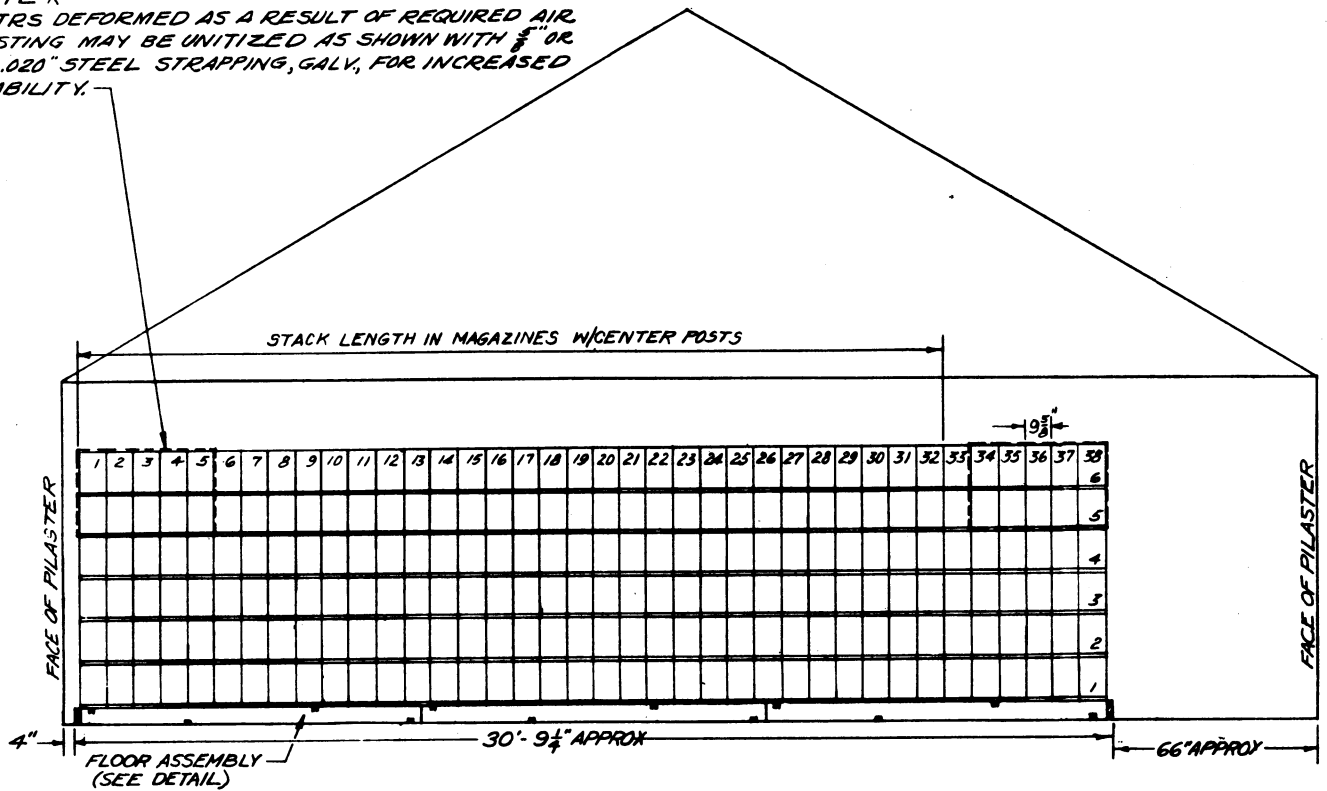

TYPICAL STACK ELEVATION
QUANTITY PER DOUBLE STACK

SMKLS POWDER MAGAZINE W/O CENTER POSTS = 456 BOXES
 SMKLS POWDER MAGAZINE WITH CENTER POSTS = 384 BOXES

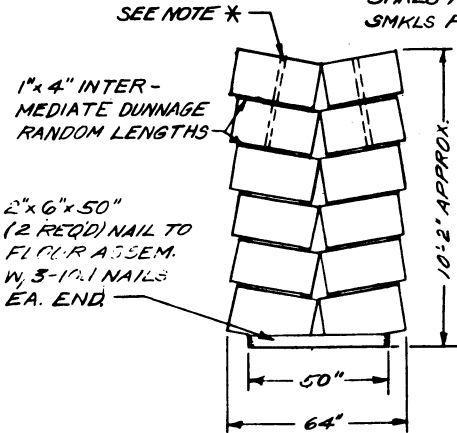

DETAIL-END OF STACK

NOTE ●
 FLOOR ASSEMBLY SHOWN ON THIS DRAWING IS INTERCHANGEABLE WITH THAT SHOWN ON DRAWING FOR METAL-LINED WOOD BOX, PAGE 8. CONSTRUCTION OF DUNNAGE PERMITS PREFABRICATION OF FLOOR ASSEMBLY.

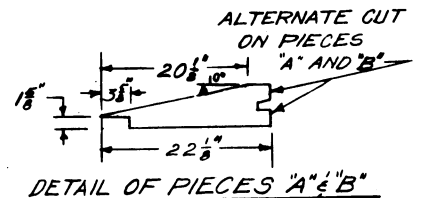
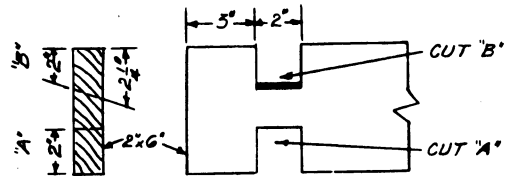
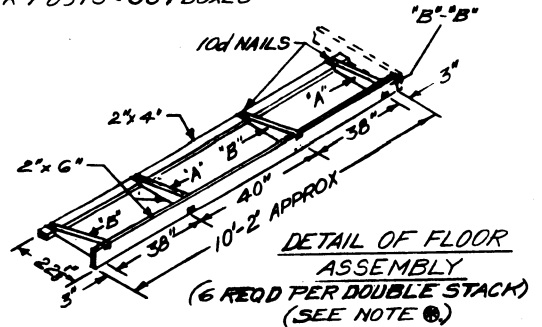

POWDER, PROPELLANT, PACKED IN BOX, STEEL, M2 & MK VII
 (BOX SIZE - 16 1/4" L x 9 5/8" W. x 28 5/8" H)
 (ANGULAR STORAGE)

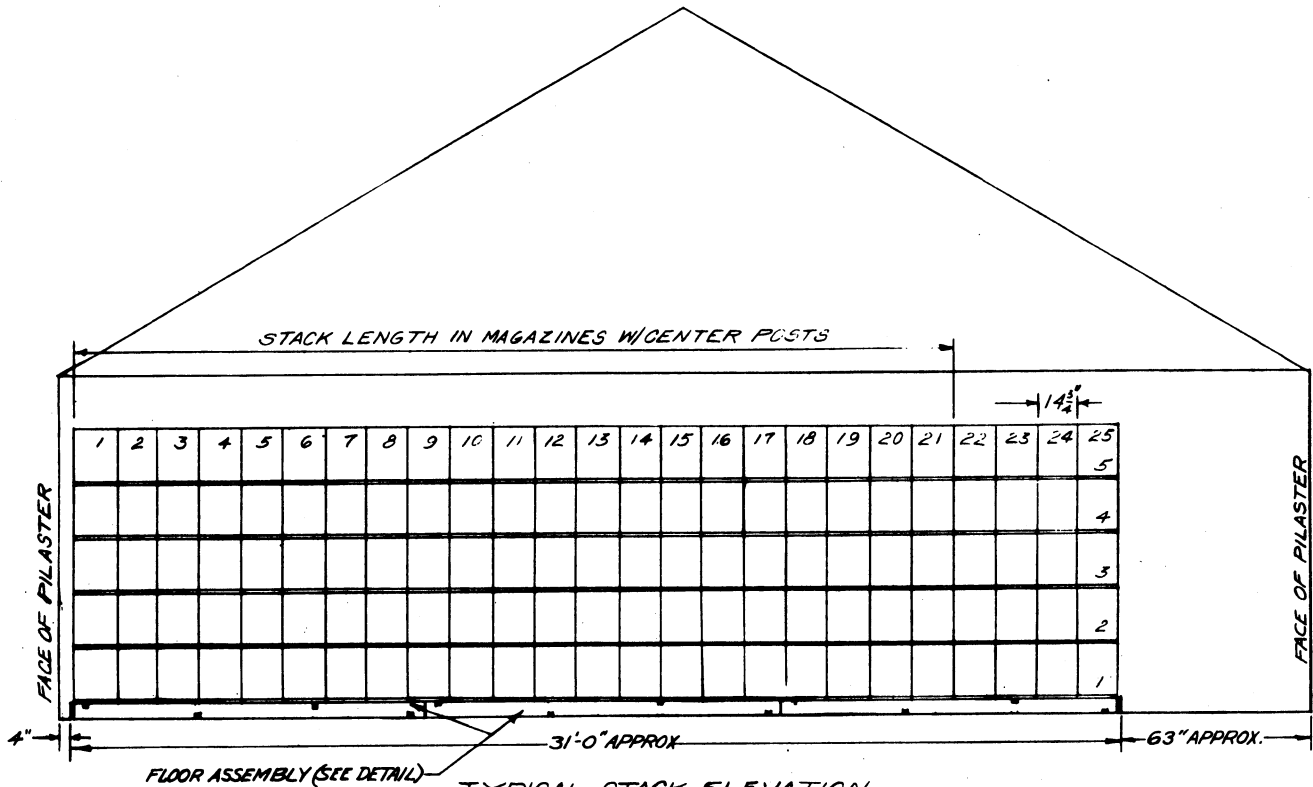

TYPICAL STACK ELEVATION
 QUANTITY PER DOUBLE STACK
 SMKLS POWDER MAG W/O CENTER POSTS = 250 BOXES
 SMKLS. POWDER MAG. WITH CENTER POSTS = 210 BOXES

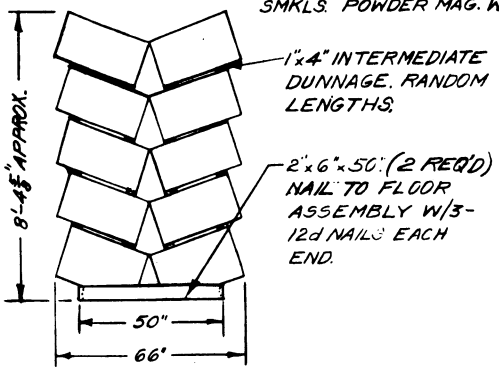

DETAIL-END OF STACK

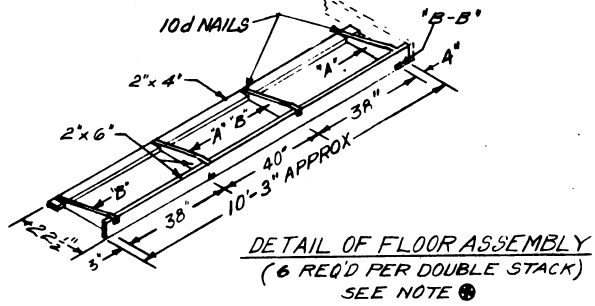

DETAIL OF FLOOR ASSEMBLY
 (6 REQ'D PER DOUBLE STACK)
 SEE NOTE ①

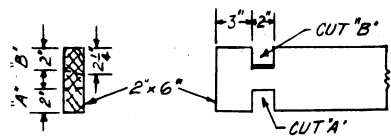

DETAIL OF PIECE "B-B"

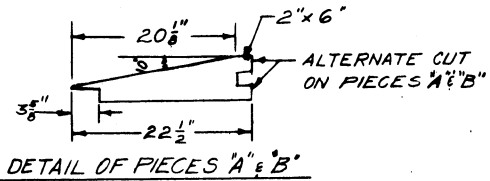

DETAIL OF PIECES "A" & "B"

NOTE ①
 FLOOR ASSEMBLY SHOWN ON THIS DWG IS INTER-CHANGEABLE WITH THAT SHOWN ON DWG FOR STEEL BOX, PAGE 7. CONSTRUCTION PERMITS PREFABRICATION OF FLOOR ASSEMBLY.

POWDER, PROPELLANT, PACKED IN METAL-LINED WOODEN BOX, M24
 (BOX SIZE - 17 3/4" L. x 14 3/4" W. x 30" H)
 (ANGULAR STORAGE)

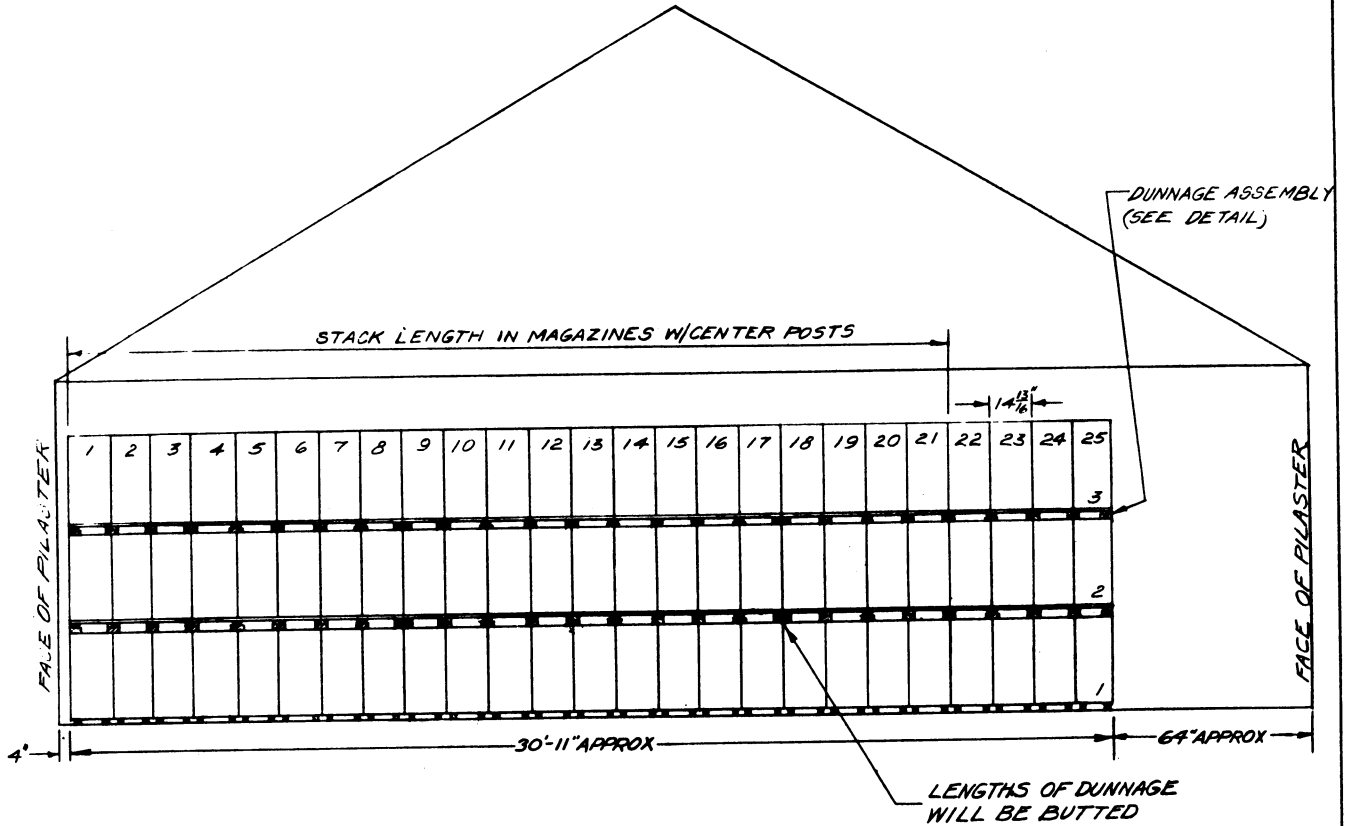

TYPICAL STACK ELEVATION
QUANTITY PER DOUBLE STACK
 SMKLS. POWDER MAGAZINE W/O CENTER POSTS - 150 BOXES
 SMKLS. POWDER MAGAZINE WITH CENTER POSTS - 126 BOXES

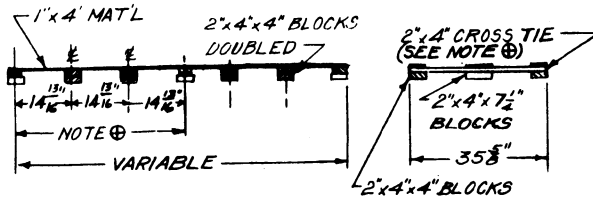

SIDE VIEW

END VIEW

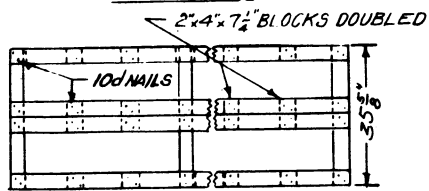

TOP VIEW
DETAIL - DUNNAGE ASSEMBLY
 (6 REQD PER DOUBLE STACK)

NOTE ⊕
 CROSS TIES WILL BE AT EACH END OF DUNNAGE ASSEMBLY AND SPACED BETWEEN EVERY 3RD AND 4TH BOX ON EACH LAYER.

DUNNAGE ASSEMBLY (SEE DETAIL)

2" x 2" x 35 5/8" FLOOR DUNNAGE POSITIONED 1 1/2" FROM EACH END OF BOX LENGTH PARALLEL TO BACK WALL OF MAGAZINE.

DETAIL-END OF STACK

POWDER PROPELLANT, PACKED IN WDN BOX, M24
 (BOX SIZE - 17 1/2" L. x 14 1/8" W. x 30" H.)
 (VERTICAL STORAGE)

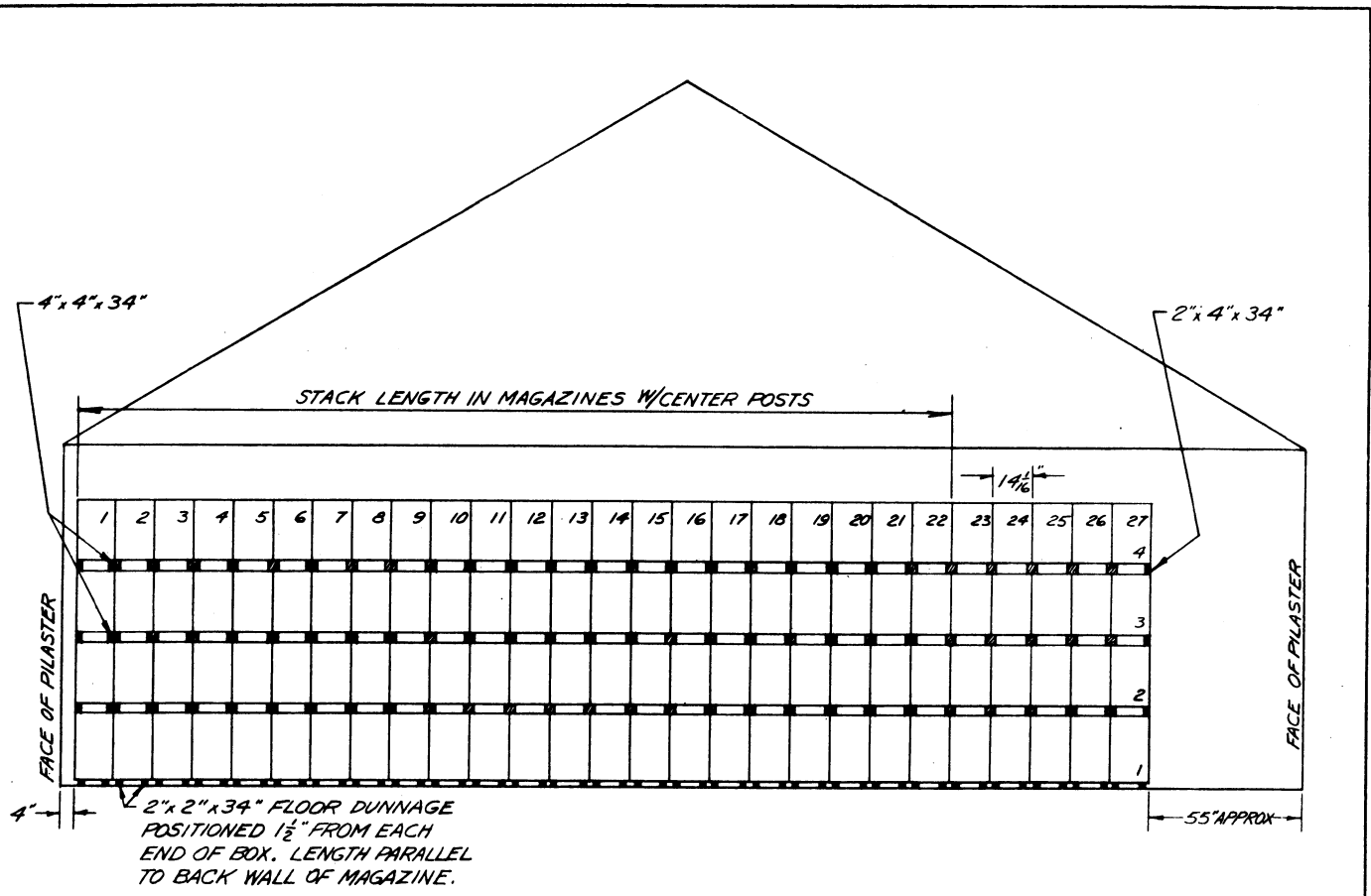

TYPICAL STACK ELEVATION
QUANTITY PER DOUBLE STACK
 SMKLS POWDER MAGAZINE W/O CENTER POSTS - 216 BOXES
 SMKLS POWDER MAGAZINE WITH CENTER POSTS - 176 BOXES

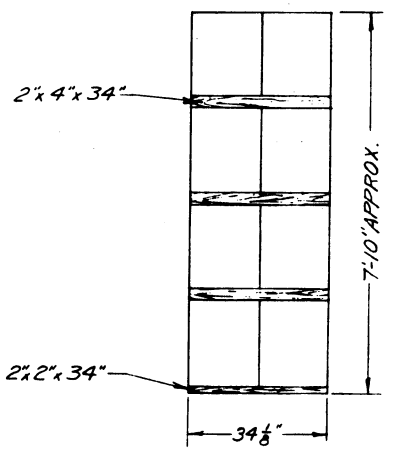

DETAIL END OF STACK

POWDER, PROPELLANT, PACKED IN M17 WDN BOX
 (BOX SIZE - 17 1/8" L x 14 1/16" W x 20 3/8" H)
 (LARGE MOUTH)

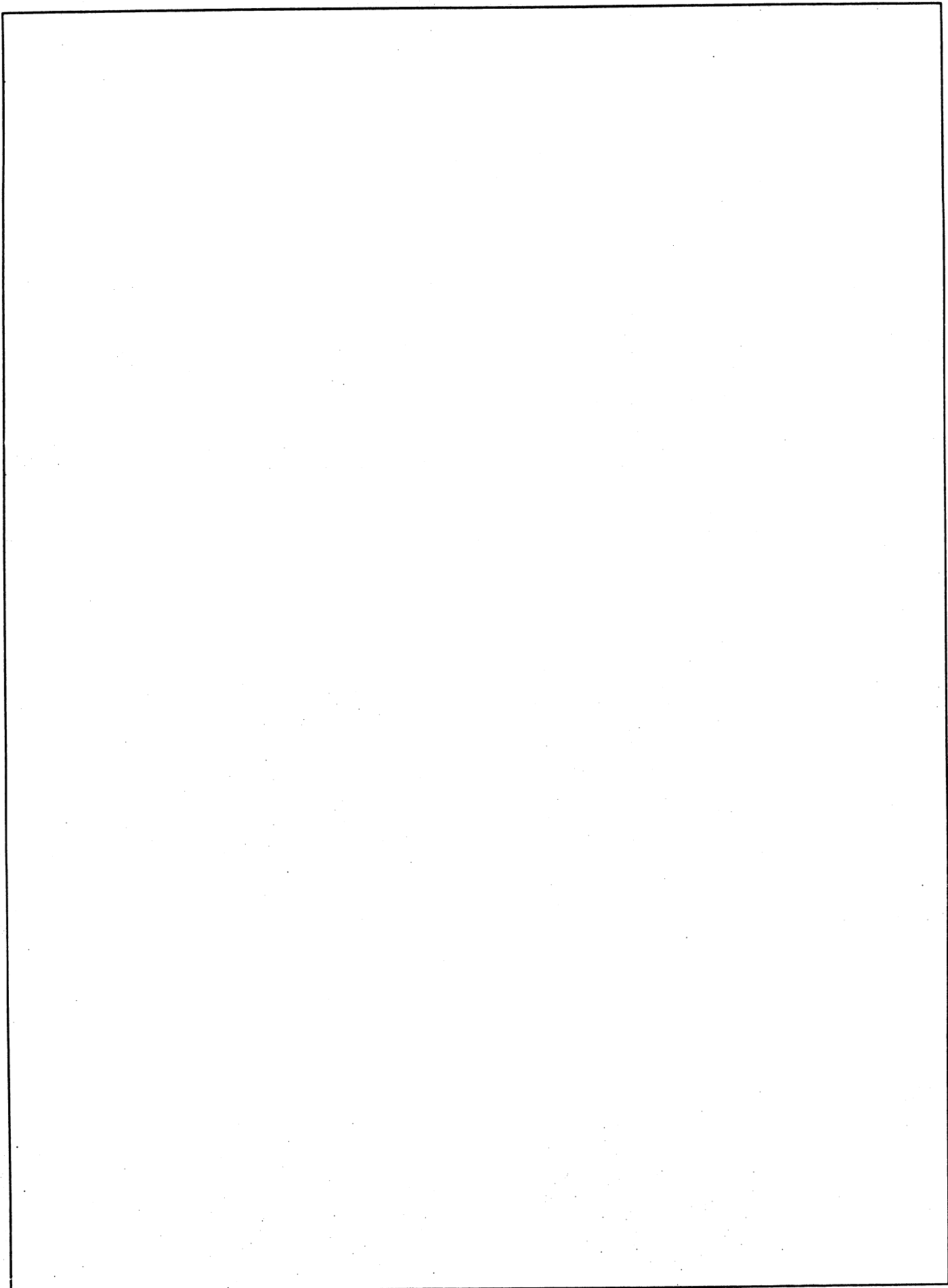

L I N E	LBS. XPL./ PKG.	PAGE FOR		MAGAZINE WITHOUT CENTER POSTS					MAGAZINE WITH CENTER POSTS					L I N E
		PLAN	ELEV.	DBL. STKS. PER MAG.	PKGS. PER MAG.	LBS. XPL. PER MAG.	MATL./DBL. STACK		DBL. STKS. PER MAG.	PKGS.* PER MAG.	LBS. XPL.* PER MAG.	MATL./DBL. STACK		
							LBR. BD. FT.	NAILS LB.				LBR. BD. FT.	NAILS LB.	
POWDER, PROPELLENT, 50 LBS. PER WDN. BOX M16														
1	50	3	4	26	10,000	500,000	826		23	7406	370,300	431		1
2														2
POWDER, PROPELLENT, M17 WOODEN BOX, (SMALL MOUTH)														
3	100	3	5	23	4416	441,600	276		20	3040	304,000	226		3
4														4
POWDER, PROPELLENT, M2 & MK III STEEL BOX, (VERTICAL)														
5	110	3	6	20	4545	499,950	303		21	4032	443,520	263		5
6														6
POWDER, PROPELLENT, M2 & MK III STEEL BOX, (ANGULAR)														
7	110	3	7	10	4545	499,950	311	1/2	12	4545	499,950	256	1/2	7
8														8
POWDER, PROPELLENT, M24 MTL. LMD. WDN. BOX, (ANGULAR)														
9	150	3	8	14	3333	499,950	311	1/2	12	2880	378,000	256	1/2	9
10														10
POWDER, PROPELLENT, M24 WDN. BOX, (VERTICAL)														
11	150	3	9	23	3333	499,950	198	3	20	2496	374,400	167	3	11
12														12
POWDER, PROPELLENT, M17 WDN. BOX, (LARGE MOUTH)														
13	100	3	10	23	4968	496,800	343		20	3880	388,000	291		13
14														14

* QUANTITIES SHOWN ARE FOR FULL STACKS. THERE MAY BE SOME LOSS DUE TO LOCATION OF CENTER POSTS.

