

# BASIC PROCEDURES

## UNITIZATION PROCEDURES FOR BOXED WHITE PHOSPHORUS (WP) AND PLASTICIZED WHITE PHOS- PHORUS (PWP) LOADED AMMUNI- TION ON 4-WAY ENTRY PALLETS

### INDEX

<u>ITEM</u>	<u>PAGE(S)</u>
GENERAL NOTES AND MATERIAL SPECIFICATIONS - - - - -	2-4
DETAILS - - - - -	5
TYPICAL UNITIZATION DETAILS - - - - -	6-7
LESS-THAN-FULL-LAYER UNIT LOADS - - - - -	8-9
TYPICAL FILLER ASSEMBLIES - - - - -	10

THIS DRAWING SUPERSEDES THE PALLETIZATION PORTIONS DELINEATED ON PAGES 2 AND 3 OF DRAWING 19-48-4015-12PA1000, DATED 7 FEBRUARY 1956, INCLUDING REVISION 2, DATED 14 OCTOBER 1967. HOWEVER, THE "PALLET UNIT" DATA WITHIN THE TABULAR DATA PORTION OF DRAWING 19-48-4015-12PA1000 WILL CONTINUE TO BE VALID FOR EACH ITEM LISTED WITHIN THAT DRAWING UNTIL SUPERSEDED BY AN APPENDIX TO THE DOCUMENT FOR THAT ITEM.

**NOTICE:**

THIS BASIC PROCEDURE DRAWING WILL BE AUGMENTED BY SEPARATELY ISSUED APPENDICES BEARING THE DRAWING AND FILE NUMBERS OF THIS DOCUMENT. AN APPENDIX WILL DELINEATE THE APPROVED CONFIGURATION OF A UNIT LOAD FOR ONE ITEM OF AMMUNITION OR FOR A CATEGORY OF AMMUNITION ITEMS. APPENDICES CANNOT STAND ALONE, BUT MUST BE USED IN CONJUNCTION WITH THIS BASIC PROCEDURE DRAWING. THE DRAWING NUMBER OF EACH APPENDIX WILL CONTAIN A SUB-NUMBER FOR IDENTIFICATION (E. G.; THE DRAWING NUMBER FOR APPENDIX 3 WILL BE 19-48-4015/3-20PA1004). APPENDICES WILL NOT NECESSARILY BE ISSUED BY NUMERICAL SEQUENCE.

**DISTRIBUTION STATEMENT A:**

APPROVED FOR PUBLIC RELEASE  
DISTRIBUTION IS UNLIMITED.

## U.S. ARMY MATERIEL COMMAND DRAWING

APPROVED, COMBAT CAPABILITIES DEVELOPMENT COMMAND ARMAMENTS CENTER HANSEN.JO.137 SEPH.W.137 6495538 Digitally signed by HANSEN.JOSEPH.W. .1376495538 Date: 2021.12.09 09:06:38 -06'00'	<b>CAUTION: VERIFY PRIOR TO USE AT <a href="https://www.dau.edu/cop/ammo/pages/default.aspx">https://www.dau.edu/cop/ammo/pages/default.aspx</a> THAT THIS IS THE MOST CURRENT VERSION OF THIS DOCUMENT. THIS IS PAGE 1 OF 10.</b>		<b>FEBRUARY 1983</b>	
APPROVED, U.S. ARMY JOINT MUNITIONS COMMAND WARD.GINA. M.1369379808 Digitally signed by WARD.GINA.M.1369379808 Date: 2021.12.09 10:19:02 -06'00'	<b>DO NOT SCALE</b>	<b>REVISION NO. 6</b>		<b>NOVEMBER 2021</b>
APPROVED BY ORDER OF COMMANDING GENERAL, U.S. ARMY MATERIEL COMMAND SMITH.THERESA. ANN.1009147639 Digitally signed by SMITH.THERESA.ANN.1009147639 Date: 2021.12.13 13:53:16 -06'00'	ENGINEER OR TECHNICIAN WILLIAM R. FRERICHS QUYEN TRAN	<b>SEE THE REVISION LISTING ON PAGE 4</b>		CLASS <b>19</b>
U.S. ARMY DEFENSE AMMUNITION CENTER	ENGINEERING DIVISON TEST ENGINEER TEST REPORT EXPLOSIVE SAFETY DIRECTORATE	FIEFFER.LAUR A.A.1230375727 Digitally signed by FIEFFER.LAURA.A.1230375727 Date: 2021.11.15 13:01:56 -06'00'	DIVISION DRAWING <b>48</b>	FILE <b>4015</b> <b>20PA1004</b>

## GENERAL NOTES

## (GENERAL NOTES CONTINUED)

- A. THIS DOCUMENT HAS BEEN PREPARED AND ISSUED IN ACCORDANCE WITH AR 740-1 AND AUGMENTS TM 743-200-1 (CHAPTER 5) AND CONFORMS TO MIL-STD-1660.
- B. APPROVED SPECIFICATIONS, COVERING THE ASSEMBLAGE AND UNITIZATION OF BOX-PACKED WHITE PHOSPHORUS (WP) OR PLASTICIZED WHITE PHOSPHORUS (PWP) FILLED AMMUNITION INTO UNIT LOADS, ARE SET FORTH IN THIS DRAWING. THIS DRAWING WILL BE CONSIDERED THE BASIC DOCUMENT FOR THE UNITIZATION OF WP AND PWP FILLED AMMUNITION ITEMS PACKED IN BOXES. THIS DOCUMENT INCLUDES MATERIAL SPECIFICATIONS AND UNITIZING STANDARDS APPLICABLE TO UNITIZATION, PLUS INFORMATION RELATIVE TO TYPICAL POSITIONING OF BOXES ON A PALLET AND INSTALLATION OF UNITIZING STEEL STRAPPING. FOR TYPICAL UNITIZATION PROCEDURES SEE PAGES 6 AND 7. ADDITIONALLY, PROCEDURES FOR LESS-THAN-FULL-LAYER UNIT LOADS ARE DELINEATED ON PAGES 8 AND 9.
- C. APPENDICES PERTAINING TO THIS BASIC DOCUMENT WILL BE ISSUED SEPARATELY. ALL APPENDICES, HOWEVER, ARE A PART OF THIS BASIC PROCEDURE DRAWING. EACH APPENDIX WILL COVER THE APPROVED CONFIGURATION FOR A UNIT LOAD, THE SPECIFIC UNITIZATION SPECIFICATIONS AND THE PERTINENT TABULAR DATA FOR ONE ITEM OF AMMUNITION OR FOR A CATEGORY OF AMMUNITION ITEMS.
- D. ALL WP AND PWP FILLED AMMUNITION COVERED BY THIS DRAWING AND ITS SEPARATELY ISSUED APPENDICES WILL BE PLACED ON THE PALLET IN THE NOSE-END UP CONFIGURATION, EXCEPT FOR RIFLE GRENADES, 3.5" ROCKETS, AND 2.75" ROCKET WARHEADS AND ROCKETS. RIFLE GRENADES AND 3.5" ROCKETS WILL BE PALLETIZED IN A NOSE-END DOWN CONFIGURATION. 2.75" COMPLETE ROCKETS, ASSEMBLED OR UNASSEMBLED, AND 2.75" ROCKET WARHEADS ARE TO BE PALLETIZED IN SUCH A MANNER SO AS TO BE MOST CONDUCTIVE TO SAFE HANDLING, SHIPPING AND STORAGE PRACTICES. 2.75" COMPLETE ROCKETS AND/OR 2.75" ROCKET WARHEADS DO NOT HAVE TO BE PALLETIZED IN A NOSE-END UP OR DOWN (VERTICAL) CONFIGURATION UNLESS DEEMED SAFER AND MORE ECONOMICAL THAN HORIZONTAL PALLETIZATION. **NOTE:** HORIZONTAL ITEM ORIENTATION ON A PALLET IS ONLY APPROVED FOR USE WITH 2.75" COMPLETE ROCKETS, ASSEMBLED OR UNASSEMBLED, AND 2.75" ROCKET WARHEADS.
- E. GENERALLY, UNIT LOADS SHOWN IN THE APPENDICES WILL CONFORM TO THE STANDARDS LISTED BELOW.
- GROSS WEIGHTS OF PALLETIZED UNIT LOADS ARE BASED ON AN OPTIMUM WEIGHT OF 2,464 POUNDS, DUE TO MATERIAL HANDLING EQUIPMENT CONSIDERATIONS. UNLESS SPECIFICALLY RESTRICTED BY ANOTHER AUTHORITY DOCUMENT, THE MAXIMUM GROSS WEIGHT OF AMMUNITION UNIT LOADS IS 4,000 POUNDS.
  - UNIT LOADS SHOULD NOT EXCEED 44" IN LENGTH BY 54" IN WIDTH FOR STYLE 1 (40" X 48") PALLET, 39" IN LENGTH BY 51-1/2" IN WIDTH FOR STYLE 1A (35" X 45-1/2") PALLET, OR 44" IN LENGTH BY 59" IN WIDTH FOR STYLE 1B (42" X 53") PALLET. UNIT LOAD HEIGHT, INCLUDING PALLET HEIGHT, SHOULD NOT EXCEED 54". ANY OR ALL OF THE STATED DIMENSIONS FOR THE LENGTH, WIDTH OR HEIGHT OF A UNIT LOAD, HOWEVER, CAN BE INCREASED OR DECREASED, DEPENDING UPON PECULIARITIES OF THE COMMODITY BEING UNITIZED AND IDENTIFIABLE FACTORS THAT INFLUENCE TOTAL COST EFFECTIVENESS THROUGHOUT THE AMMUNITION LOGISTICS SYSTEM.

(CONTINUED AT RIGHT)

## MATERIAL SPECIFICATIONS

- PALLET** - - - - - : MIL SPEC MIL-DTL-15011; 4-WAY ENTRY, STYLE 1, 1A OR 1B, TYPE I, CLASS 1, PRESERVATIVE AND HEAT TREATED. SEE GENERAL NOTE "KK" ON PAGE 4.
- LUMBER** - - - - - : SEE TM 743-200-1 (DUNNAGE LUMBER) AND VOLUNTARY PRODUCT STANDARD PS 20 FOR FILLER ASSEMBLIES. ASTM D 6199; CLASS 2, GROUP II, III, OR IV, PRESERVATIVE AND HEAT TREATED FOR OTHER DUNNAGE ASSEMBLIES. NOTE: ONLY GROUP IV LUMBER IN ACCORDANCE WITH ASTM D6199 WILL BE ACCEPTABLE FOR THE CONSTRUCTION OF THE PALLET. SEE GENERAL NOTES "BB" ON PAGE 3 AND "KK" ON PAGE 4.
- NAILS** - - - - - : ASTM F1667; COMMON STEEL NAIL (NLCMS OR NLCMS). ALT: UNDERLAYMENT NAIL (NLUL), PALLET NAIL (NLPL), OR COOLER NAIL (NLCL) OF SAME SIZE. SEE GENERAL NOTE "HH" ON PAGE 4.
- PLYWOOD** - - - - - : COMMERCIAL ITEM DESCRIPTION A-A-55057, INDUSTRIAL PLYWOOD, INTERIOR WITH EXTERIOR GLUE, GRADE C-D. IF SPECIFIED GRADE IS NOT AVAILABLE, A BETTER INTERIOR OR AN EXTERIOR GRADE MAY BE SUBSTITUTED.
- STRAPPING, STEEL** - - - : ASTM D3953; FLAT STRAPPING, TYPE 1, HEAVY DUTY, FINISH B (GRADE 2), SIZE 3/4" X .035" OR .031" OR .029". ALTERNATIVE SIZE 1-1/4" X .035" OR .031" OR .029". NOTE: IF EDGES DO NOT MEET THE PREECE TEST FOR GRADE 2, ANY BRITTE OR SLIT EDGES SHALL HAVE FINISH A OVERLAY APPLIED.
- SEAL, STRAP** - - - - : ASTM D3953; CLASS H, FINISH B (GRADE 2), DOUBLE NOTCH TYPE, STYLE I, II, III, OR IV. ALTERNATIVE SEAL FINISH: SIGNODE OR DELTA PAINTED SEALS MAY BE USED AS AN ALTERNATIVE IF ALL SURFACES ARE PAINTED. GRITTED BACKING IS NOT PERMITTED.
- STAPLE, STRAP** - - - : ASTM F1667; STFCs-189 OR STFCs-207, 15/16" OR 1" CROWN WIDTH X 3/4" LEG LENGTH FOR 3/4" STRAPPING OR STFCs-224, 1-17/32" CROWN WIDTH X 3/4" LEG LENGTH FOR 1-1/4" STRAPPING. SEE GENERAL NOTE "Q" ON PAGE 3.

- THE UNIT LOAD SHOULD EITHER BE FLUSH WITH OR SLIGHTLY OVERHANG THE PALLET ON ALL FOUR SIDES. OVERHANG IS DEFINED AS THE DISTANCE THAT THE AMMUNITION ITEM PACKAGE(S) EXTENDS BEYOND THE EDGE OF THE PALLET. WHEN THE EDGE OF THE AMMUNITION ITEM PACKAGE(S) DOES NOT REACH THE EDGE OF THE PALLET, SPACER ASSEMBLIES OR BATTENS WILL BE POSITIONED WITHIN THE UNIT LOAD IN ACCORDANCE WITH SPECIFICATIONS OF THE APPLICABLE APPENDIX AND AS TYPICALLY SHOWN ON PAGE 7. SEE GENERAL NOTE "W" ON PAGE 3.
- AN AMMUNITION BOX (EXTERIOR PACK) WILL NOT CONTAIN MORE THAN ONE LOT OF AMMUNITION PER BOX. UNIT LOADS WILL NOT CONTAIN MORE THAN TWO LOTS PER UNIT LOAD, EXCEPT WHERE REQUIRED FOR BALLISTIC SAMPLE SHIPMENT OR FOR TROOP USE AT POST, CAMP OR STATION. SEE GENERAL NOTE "S" ON PAGE 3, AND GENERAL NOTE "EE" ON PAGE 4 FOR ADDITIONAL GUIDANCE.
- LESS-THAN-FULL BOXES OF AN AMMUNITION ITEM (LIGHT BOXES) ARE LIMITED TO ONLY ONE LIGHT BOX PER ITEM LOT. A UNIT LOAD WILL NOT CONTAIN MORE THAN ONE LIGHT BOX PER ITEM LOT ON A PALLET. ADDITIONAL REQUIREMENTS ARE SPECIFIED IN THE "PROVISIONS FOR LESS-THAN-FULL-LAYER UNIT LOADS" ON PAGES 8 AND 9.
- A UNIT LOAD, SUCH AS THE LAST UNIT LOAD FOR AN AMMUNITION LOT, CAN BE ASSEMBLED WITH LESS LAYERS THAN SPECIFIED FOR THE BASIC UNIT LOAD. THE UNIT LOAD CAN ALSO BE ASSEMBLED WITH A PARTIAL TOP LAYER PROVIDING IT IS TO BE SHIPPED WITHIN CONUS TO A DEPOT, DEPOT ACTIVITY, POST, CAMP, OR STATION. FOR CONUS OR FOREIGN MILITARY SALES (FMS) SHIPMENTS, HOWEVER, THE UNIT LOAD MUST NOT BE ASSEMBLED WITH A PARTIAL LAYER. EMPTY BOXES OR FILLER ASSEMBLIES WILL BE USED TO ACHIEVE FULL-LAYER CONFIGURATION. FOR ADDITIONAL GUIDANCE, SEE GENERAL NOTE "G" AND THE "LESS-THAN-FULL LAYER UNIT LOADS" PROCEDURES ON PAGES 8 AND 9.
- ANY REQUEST FOR DEVIATION FROM THE STANDARDS DESCRIBED IN GENERAL NOTE "E" OR FROM THE PROCEDURES DELINEATED IN AN APPENDIX MUST BE DIRECTED TO THE COMMANDER, DEVCOM ARMAMENTS CENTER, ATTN: FCDD-ACE-LTP, ROCK ISLAND, IL 61299-7300, FOR SPECIFIC APPROVAL. FOR EXAMPLE, SPECIFIC APPROVAL MUST BE OBTAINED FOR UNITIZATION OF AN ITEM WHEN PACKED IN BOXES WHICH ARE DIFFERENT IN SIZE THAN THOSE SHOWN IN THE APPENDIX FOR THAT ITEM, EVEN THOUGH THE UNIT LOAD MAY COMPLY WITH THE STANDARDS DESCRIBED IN GENERAL NOTE "E". CONFIGURATION MANAGEMENT PROCEDURES CONTAINED IN MIL-STD-973 DO NOT APPLY TO THIS DRAWING OR ANY APPENDICES THERETO. OR FOR EXAMPLE, BOXES OR CONTAINERS NOT SPECIFICALLY INCLUDED IN THE APPENDICES TO THIS BASIC DRAWING SHOULD BE PALLETIZED IN GENERAL CONFORMANCE TO THIS DRAWING.
- EXCEPT AS OTHERWISE STATED WITHIN GENERAL NOTE "E.6" ABOVE, UNIT LOADS MUST ONLY BE MADE UP WITH FULL LAYERS. FOR REDUCED QUANTITIES, HOWEVER, ONE OR MORE FULL LAYERS MAY BE OMITTED, AND/OR A FULL LAYER MAY CONSIST OF BOXED ITEMS AND A FILLER ASSEMBLY OR AN EMPTY BOX(ES). SEE THE PROVISIONS FOR "LESS-THAN-FULL-LAYER UNIT LOADS" ON PAGES 8 AND 9. ONLY ONE UNIT LOAD HAVING A REDUCED QUANTITY OF ITEMS SHOULD BE PERMITTED PER LOT OF THAT ITEM. EACH LAYER OF BOXES WILL BE POSITIONED SO AS TO BE CENTERED LENGTHWISE AND WIDTHWISE ON THE DECK OF THE PALLET. CARE SHALL BE TAKEN TO ENSURE THAT THE BOXES ARE EVENLY ALIGNED HORIZONTALLY AND VERTICALLY SO THAT THE SIDES AND ENDS OF THE UNIT LOAD DO NOT EXCEED A 1/2" TOLERANCE, RELATIVE TO THE PALLET DECK. SEE "UNIT ASSEMBLY TOLERANCES" DETAILS ON PAGE 5. ALSO, SEE GENERAL NOTE "X" ON PAGE 3 AND THE "TYPICAL FILLER ASSEMBLIES" ON PAGE 10.
- GENERALLY, WHEN UNITIZING BOXES WITH TOP CLEATS, BOXES WILL BE POSITIONED ON THE UNIT LOAD WITH CLEATS UPWARD. IF BOXES ARE OF THE HINGED-TOP TYPE, THE OUTSIDE BOXES IN THE TOP LAYER WILL BE POSITIONED SO THAT THE HINGES WILL BE INWARD. **CAUTION:** ROCKETS AND ROCKET MOTORS IN A PROPULSIVE STATE WILL BE POSITIONED IN THE UNIT LOAD WITH ALL NOSE ENDS IN ONE DIRECTION. UNIT LOAD STRAPS, IN THESE INSTANCES, MAY PASS OVER HINGES OF BOXES. ALSO, SEE GENERAL NOTE "CC" ON PAGE 3.
- A PLUS-OR-MINUS 1/4" IS ALLOWED ON OVERALL DIMENSIONS OF A FILLER ASSEMBLY, SPACER ASSEMBLY OR ANY OTHER DUNNAGE ASSEMBLY. HOWEVER, SIMILAR PIECES IN AN ASSEMBLY MUST BE WITHIN 1/8" OF THE SAME DIMENSION. AN AMMUNITION BOX (EXTERIOR PACK) WILL NOT CONTAIN MORE THAN ONE LOT OF AMMUNITION PER BOX.
- DIMENSIONAL LUMBER SPECIFIED THROUGHOUT THIS PROCEDURAL DRAWING IS OF NOMINAL SIZE UNLESS OTHERWISE SPECIFIED. FOR EXAMPLE, 1" X 4" MATERIAL IS ACTUALLY 3/4" THICK BY 3-1/2" WIDE AND 2" X 4" MATERIAL IS ACTUALLY 1-1/2" THICK BY 3-1/2" WIDE.
- IN ORDER TO OBTAIN COMPACT (SOUND) UNITS, ALL STRAPS SHALL BE LOCATED IN PROPER ALIGNMENT AND TENSIONED UNTIL THEY CUT INTO THE EDGE OF THE BOXES AND/OR THE PALLET DECK. AFTER TENSIONING, EACH STRAP WILL BE SECURED USING ONE SEAL AND TWO PAIR OF NOTCHES PER SEAL. SEE "ALLOWABLE TOLERANCES FOR ASSEMBLING UNITS" DETAILS ON PAGE 5. SEALS MAY BE LOCATED ON A SIDE OR ON THE TOP OF THE UNIT, AS REQUIRED BY OPERATIONAL NECESSITY. ALSO, SEE GENERAL NOTE "JJ" ON PAGE 4 FOR ACCEPTABLE SEALLESS OR CLIPLESS TOOL INFORMATION.
- WHEN APPLYING ANY STRAP, CARE MUST BE EXERCISED TO ENSURE THAT THE END OF THE STRAP ON THE UNDERSIDE OF THE JOINT EXTENDS AT LEAST 6" BEYOND THE SEAL. THIS EXTRA MINIMUM LENGTH OF THE STRAP IS REQUIRED TO PERMIT SUBSEQUENT TIGHTENING OF LOOSENED STRAPPING. RETENSIONING CAN BE ACCOMPLISHED WITHOUT REPLACING STRAPPING OR SPLICING STRAPPING THROUGH THE USE OF A MANUAL OR PNEUMATIC FEEDWHEEL TYPE TENSIONING TOOL AND THE APPLICATION OF ONE ADDITIONAL SEAL. SEE "STRAP RETENSIONING TAB" VIEW ON PAGE 6.

(CONTINUED ON PAGE 3)

(GENERAL NOTES CONTINUED FROM PAGE 2)

N. DETERMINATION OF LENGTH OF STRAPPING. THE FOLLOWING DEFINITIONS APPLY:

L = LENGTH OF STRAP REQUIRED IN INCHES  
A = LENGTH OF UNIT IN INCHES  
W = WIDTH OF UNIT IN INCHES  
H = HEIGHT OF UNIT, INCLUDING PALLET, IN INCHES

1. THE LENGTH OF A LOAD STRAP REQUIRED FOR A SPECIFIC UNIT, WHERE THE STRAP PASSES THROUGH THE STRAP SLOT OR ABOVE THE PALLET DECK, WILL BE DETERMINED BY USING THE FOLLOWING FORMULA:  
 $L = 2W + 2H + 2"$ .
2. THE LENGTH OF A HORIZONTAL STRAP REQUIRED FOR A SPECIFIC UNIT, WHERE THE STRAP ENCIRCLES THE UNIT LOAD, WILL BE DETERMINED BY USING THE FOLLOWING FORMULA:  $L = 2A + 2W + 12"$ .
3. THE LENGTH OF A TIEDOWN STRAP REQUIRED FOR A SPECIFIC UNIT, WHERE THE STRAP PASSES UNDER THE PALLET DECK, WILL BE DETERMINED BY USING THE FOLLOWING FORMULA:  $L = 2A + 2H + 2"$ .

O. PALLET UNIT LOADS SHALL BE INSPECTED FOR TORN, DETERIORATED OR LOOSENED STRAPPING PRIOR TO SHIPPING.

1. TORN OR BROKEN STRAPS SHOULD BE REPLACED BY CONTRACTORS, BUT MAY BE REPAIRED AT THE DEPOT/FIELD LEVEL BY SPLICING IN A MANNER SIMILAR TO THAT DESCRIBED IN "O.4(B)" BELOW.
2. DETERIORATION DUE TO A MINOR AMOUNT OF RUST WILL NOT NECESSARILY BE CAUSE FOR REPLACING A STRAP. HOWEVER, AN EXTENSIVELY RUSTED/SCALED/PITTED STRAP IS CAUSE FOR REPLACING THE STRAP.
3. A DAMAGED OR DEFECTIVE SEAL IS SUFFICIENT CAUSE FOR REPLACEMENT OF THE SEAL.
4. LOOSE STRAPS SHOULD BE CHECKED FOR DEGREE OF LOOSENESS BY POSITIONING THE HOOK OF A SCALE (COMMONLY KNOWN AS A FISH SCALE) BEHIND THE STRAPS NEAR THE MIDPOINT AT THE TOP OR SIDE OF THE UNIT LOAD. PULL THE SCALE UNTIL A READING OF 20 POUNDS IS OBTAINED. THE DISTANCE BETWEEN THE BOX AND THE STRAP MUST NOT EXCEED 1-1/2". IF MEASUREMENT EXCEEDS 1-1/2", THE STRAP MUST BE TIGHTENED OR REPLACED. SEE PAGE 6 FOR GUIDANCE. TIGHTENING CAN BE ACCOMPLISHED BY EITHER OF TWO METHODS.

(A) A STRAP TENSIONING TOOL CAN BE USED IF THE STRAP HAS AT LEAST A 6" LONG TAB AT THE SEAL. SEE GENERAL NOTE "M" ON PAGE 2.

(B) AN 18" OR LONGER STRAP CAN BE USED AS A SPLICE PIECE. CUT THE LOOSE STRAP ON BOTH SIDES OF THE ORIGINAL SEAL AND DISCARD THE CUT OUT SECTION. OVERLAP ONE END OF THE STRAP SPLICE PIECE TO ONE END OF THE ORIGINAL STRAPPING SO AS TO PROTRUDE SLIGHTLY BEYOND THE END OF THE SEAL TO BE USED. POSITION AND SECURE SEAL TO OVERLAPPED SECTION WITH TWO PAIR OF NOTCHES. USING A STRAPPING TOOL, TENSION AND SEAL THE LENGTHENED STRAP. THE STRAP SPLICE PIECE MAY BE CUT FROM NEW STRAP OR USED STRAP, PROVIDED IT IS AT LEAST OF AS GOOD A QUALITY AS THE STRAP TO WHICH IT IS BEING SECURED. **NOTE:** ONLY ONE SPLICE PER STRAP IS ALLOWED ON UNIT LOADS OF AMMUNITION.

5. **CAUTION:** WHEN A STRAP IS REPLACED/SPLICED OR RETENSIONED, AND THE OTHER STRAPS ON A UNIT LOAD ARE NOT, CARE MUST BE EXERCISED TO ENSURE THAT THE TENSION ON THE AFFECTED STRAP IS NEARLY THE SAME AS THAT OF THE OTHER STRAPS.

P. AMMUNITION UNITIZED PRIOR TO DISTRIBUTION OF THIS DRAWING OR OF AN APPENDIX THERETO, NEED NOT BE REUNITIZED SOLELY TO CONFORM TO THE STANDARDS SPECIFIED HEREIN OR TO THE METHOD SHOWN IN AN AUGMENTING APPENDIX. HOWEVER, BOX AND STRAP ALIGNMENT MUST CONFORM TO THE TOLERANCE STANDARDS SPECIFIED ON PAGE 5 OF THIS DRAWING BEFORE A UNIT IS ACCEPTABLE FOR SHIPMENT. ALSO, THE CONDITION OF THE UNITIZING STRAPPING ON A UNIT LOAD MUST COMPLY WITH THE CRITERIA OF GENERAL NOTE "O" ABOVE.

Q. ROOFING NAILS IN ACCORDANCE WITH ASTM F1667 NL RF R-02Z MAY BE USED AS AN ALTERNATE TO STAPLES FOR SECURING STEEL STRAPS TO BOARDS. NAILS MUST BE APPLIED NEXT TO THE STRAPPING SUCH THAT THE NAIL HEADS OVERLAP THE STRAPPING. APPLY TWO NAILS IN PAIRS (TO REPLACE ONE STAPLE) ON EITHER SIDE OF THE STRAP, WITH THE SECOND NAIL APPLIED APPROXIMATELY 180 DEGREES FROM THE FIRST NAIL.

R. UNIT LOAD MARKING WILL BE ACCOMPLISHED IN ACCORDANCE WITH DAC DRAWING ACV00561, UNIT LOAD MARKING FOR SHIPMENT AND STORAGE, AMMUNITION AND EXPLOSIVES.

S. IF THE REQUISITION QUANTITY IN SUPPORT OF AN AMMUNITION SHIPMENT IS LESS THAN A FULL LAYER QUANTITY OF BOXES FOR A UNIT LOAD, THE BOXES NEED NOT BE PALLETIZED FOR SHIPMENT. THE BOXES MAY BE PALLETIZED, HOWEVER, FOR ENHANCED HANDLING, CLASSIFIED/SENSITIVE ITEM CONSIDERATIONS, ETC., BUT DO NOT REQUIRE FILLER ASSEMBLIES TO COMPLETELY FILL OUT THE PALLET. NOTE THAT THE METHOD FOR BRACING AND STAYING ON THE LOOSE OR PALLETIZED BOXES MUST COMPLY WITH THE METHODS SPECIFIED WITHIN THE APPLICABLE 19-48 SERIES OUTLOADING PROCEDURAL DRAWING.

(CONTINUED AT RIGHT)

(GENERAL NOTES CONTINUED)

T. OUTLOADING AND STORAGE OF PALLET UNITS SHALL BE ACCOMPLISHED IN ACCORDANCE WITH DRAWINGS IDENTIFIED WITHIN AMC DRAWING 19-48-75-5, OR WITH APPLICABLE PROCEDURAL DRAWINGS AS IDENTIFIED IN THE APPENDICES FOR SPECIFIC UNITS. SOME OF THESE DRAWINGS ARE AVAILABLE ON THE INTERNET AT [HTTP://WWW.DAC.ARMY.MIL](http://www.dac.army.mil).

U. CONVERSION TO METRIC EQUIVALENTS: DIMENSIONS WITHIN THIS DOCUMENT ARE EXPRESSED IN INCHES, AND WEIGHTS ARE EXPRESSED IN POUNDS. WHEN NECESSARY, THE METRIC EQUIVALENTS MAY BE COMPUTED ON THE BASIS OF ONE INCH EQUALS 25.4MM AND ONE POUND EQUALS 0.454 KG.

V. WHEN ASSEMBLING A COMPLETE PALLET UNIT, CARE SHALL BE TAKEN TO ENSURE THAT THE AMMUNITION ITEM PACKAGES AND DUNNAGE ASSEMBLIES, AS APPLICABLE, ARE EVENLY ALIGNED SO THAT THE SIDES AND ENDS OF THE PALLET UNIT DO NOT EXCEED A 1/2" TOLERANCE, RELATIVE TO THE PALLET. SEE THE "ALLOWABLE TOLERANCES FOR ASSEMBLING UNITS" DETAILS ON PAGE 5.

W. A SPACER ASSEMBLY WILL BE DESIGNED SO THAT BOXES ON EACH SIDE OF A VOID WITHIN A UNIT LOAD WILL BE BRACED AS STRONGLY AS IF THE VOID WAS OCCUPIED BY THE BOXES THAT MAKE UP THE UNIT LOAD. ALSO, A SPACER ASSEMBLY WILL BE DESIGNED IN A MANNER THAT WILL PREVENT DAMAGE TO ADJACENT BOXES. GENERALLY, VERTICAL PIECES OF AN ASSEMBLY WILL BE INSTALLED AT THE OUTER EDGES OF A UNIT LOAD AND AT LOCATIONS TO BE CENTERED ON ALL VERTICAL JOINTS BETWEEN ADJACENT STACKS. ADDITIONALLY, AS GENERAL GUIDANCE, HORIZONTAL PIECES OF AN ASSEMBLY WILL BE INSTALLED AT THE TOP AND BOTTOM OF THE TOP AND BOTTOM LAYERS, RESPECTIVELY, AND AT LOCATIONS TO BE CENTERED ON ALL HORIZONTAL JOINTS BETWEEN LAYERS. WHEN A SPACER ASSEMBLY IS REQUIRED TO BE USED WITHIN A UNIT LOAD, THE CONSTRUCTION SPECIFICATIONS AND DETAIL WILL BE PROVIDED WITHIN THE APPLICABLE APPENDIX FOR THE ITEM TO BE UNITIZED.

X. FILLER ASSEMBLIES ARE DESIGNED SO AS TO PROVIDE LATERAL AND LONGITUDINAL BRACING WITHIN THE UNIT LOAD EQUIVALENT TO OR GREATER THAN THE STRENGTH OF THE BOX(ES) BEING OMITTED FROM A LAYER. WHEN A FILLER ASSEMBLY IS REQUIRED TO BE USED WITHIN A UNIT LOAD, THE CONSTRUCTION SPECIFICATIONS AND DETAILS WILL BE PROVIDED IN THE APPLICABLE APPENDIX FOR THE ITEM TO BE UNITIZED. SEE THE TYPICAL FILLER ASSEMBLY DETAILS ON PAGE 10.

Y. WHEN UNITIZING ITEMS PACKED IN WIREBOUND BOXES, AN END CLEAT OF A BOX MAY BREAK OR BECOME DEFORMED TO AN UNACCEPTABLE DEGREE DUE TO STRAP TENSIONING. IN THE INITIAL ASSEMBLY OF A UNIT LOAD AT A FACILITY, SUCH AS A MANUFACTURING PLANT, A BOX WITH A BROKEN OR BADLY DEFORMED END CLEAT WILL BE REPLACED AND THE UNIT RE-STRAPPED AS REQUIRED. IF IT IS IMPOSSIBLE TO INSTALL A UNITIZING STRAP NEAR A BOX END CLEAT, A 1" X 3" FILLER BLOCK MAY BE PLACED UNDER A STRAP TO PROVIDE ADDITIONAL STRENGTH FOR THE BOX. THE FILLER BLOCK LENGTH WILL BE CUT-TO-FIT BETWEEN OPPOSITE CLEATS, AND IT WILL BE SECURED TO THE STRAP WITH TWO STAPLES. DUNNAGE GRADE OR A BETTER GRADE LUMBER CAN BE USED FOR FILLER BLOCKS. IF DURING HANDLING, OUTLOADING OR STORAGE OPERATIONS A UNIT LOAD IS FOUND WITH A BOX WHICH HAS A BROKEN OR DEFORMED END CLEAT AND A REPLACEMENT BOX IS NOT AVAILABLE OR IT IS DEEMED IMPRACTICAL TO REPLACE THE BOX, AN ACCEPTABLE "FIX" CAN BE ACCOMPLISHED BY USING A FILLER BLOCK AS SPECIFIED ABOVE. INSERT A BLOCK BETWEEN CLEATS AT THE BREAK OR DEFORMATION. RETENSION EXISTING STRAPPING IF POSSIBLE OR INSTALL NEW STRAPPING AS REQUIRED. SEE THE "SPECIAL REINFORCEMENT FOR WIREBOUND BOXES" DETAIL ON PAGE 6.

Z. WHEN UNITIZING ITEMS PACKED IN WIREBOUND BOXES, ALLOWABLE OVERHANG FOR THE BOXES IS AS FOLLOWS: WIREBOUND BOXES CONTAINING RECTANGULAR METAL CONTAINERS AS INNER PACKS CAN OVERHANG THE PALLET AS SPECIFIED IN GENERAL NOTE "E" ON PAGE 2. WIREBOUND BOXES WITH INNER PACKS OTHER THAN RECTANGULAR METAL CONTAINERS WILL NOT OVERHANG THE PALLET IN EXCESS OF ONE-HALF THE THICKNESS OF THE BATTENS OR END CLEATS OF THE BOX, UNLESS SUPPORTED BY DUNNAGE MATERIAL FASTENED TO THE PALLET DECK, OR AS SPECIFIED WITH A SEPARATELY ISSUED APPENDIX.

AA. DIMENSIONS GIVEN FOR DUNNAGE ASSEMBLIES WILL BE FIELD CHECKED PRIOR TO THEIR ASSEMBLY. THIS GUIDANCE MUST BE APPLIED PRIOR TO BEGINNING A PALLETIZING OPERATION. ALSO, DUE TO VARIATIONS OF PACKAGE DIMENSIONS, ADJUSTMENTS MAY BE REQUIRED AS TO THE LOCATION OF CERTAIN PIECES ON DUNNAGE ASSEMBLIES. THESE ASSEMBLIES SHALL NOT PROTRUDE PAST THE TOP AND/OR SIDES OF THE BOXES.

BB. ALL WOODEN DUNNAGE USED IN UNIT LOADS SHALL BE TREATED WITH EITHER TYPE I OR TYPE III WOOD PRESERVATIVE, IN ACCORDANCE WITH ARDEC DRAWING 13064136. IF THE DUNNAGE CONSISTS OF MORE THAN ONE COMPONENT, IT MUST BE ASSEMBLED PRIOR TO TREATMENT. PRESERVATIVE MARKING SHALL BE APPLIED TO AT LEAST ONE LOCATION ON THE ASSEMBLY OR COMPONENT IN ACCORDANCE WITH PARAGRAPH 3.3.6 OF ARDEC DRAWING 13064136.

CC. WHEN UNITIZING BOXES WITH TOP CLEATS AND THE BOXES ARE POSITIONED ON THEIR SIDES, THE BOXES LOCATED IN THE OUTER STACKS MUST HAVE THE TOP CLEATS TURNED INWARD, EXCEPT AS OTHERWISE SPECIFIED IN DAC DRAWING ACV00561.

(CONTINUED ON PAGE 4)

(GENERAL NOTES CONTINUED FROM PAGE 3)

- DD. WHERE 3/4" UNITIZING STEEL STRAPPING IS SPECIFIED FOR USE BY AN APPENDIX THAT AUGMENTS THIS DRAWING, 1-1/4" STRAPPING MAY BE SUBSTITUTED FOR THE 3/4" STRAPPING, PROVIDED THAT TWO BASIC REQUIREMENTS ARE SATISFIED. ALL OF THE SPECIFICATION CRITERIA SET FORTH UNDER THE "MATERIAL SPECIFICATIONS" FOR THE 3/4" STRAPPING AND STRAP SEALS WILL BE USED FOR THE 1-1/4" STRAPPING AND SEALS, EXCEPT FOR THE SIZE CRITERION. APPROVAL TO USE THE ALTERNATIVE MATERIALS MUST BE ACQUIRED IN ACCORDANCE WITH THE GUIDANCE SET FORTH BY GENERAL NOTE "F" ON PAGE 2 PRIOR TO USING THE 1-1/4" STRAPPING AND SEALS. **NOTICE:** REQUESTS TO USE SUBSTITUTE MATERIALS MUST BE HANDLED ON A CASE BY CASE BASIS. AN APPROVAL TO USE 1-1/4" MATERIALS IS NOT A BLANKET APPROVAL TO ALL APPENDICES.
- EE. GENERAL NOTE "E.4" ON PAGE 2 SPECIFIES THAT NO MORE THAN TWO LOTS OF AMMUNITION WILL BE CONTAINED ON A PALLET UNLESS IN SUPPORT OF BALLISTIC SAMPLE SHIPMENT OR TROOP USE AT POST, CAMP, OR STATION. THIS IS INTENDED TO BE APPLIED TO PALLETIZING OPERATIONS BEING PERFORMED AT A LOAD, ASSEMBLE AND PACK PLANT OR TO MAJOR MAINTENANCE OPERATIONS BEING PERFORMED AT AN AMMUNITION DEPOT WHEN THE QUANTITY OF BOXES COMPRISING A LOT IS GREAT ENOUGH TO CONSTRUCT MORE THAN ONE PALLET UNIT. **NOTICE:** MULTIPLE (MORE THAN TWO) LOTS ARE PERMITTED TO BE PALLETIZED TOGETHER AS A UNIT LOAD WHEN A SINGLE LOT QUANTITY IS INSUFFICIENT TO COMPLETE ONE FULL-SIZE OR REDUCED-LAYER (TO SATISFY A SMALL-QUANTITY SHIPMENT) UNIT LOAD. ADDITIONALLY, MULTIPLE LOTS ON A PALLET MAY CONSIST OF ONE OR MORE NSNS, PROVIDED ALL ITEMS ARE COMPATIBLE AND THEY ARE BEING SHIPPED TO A SINGLE CONUS POST, CAMP OR STATION. PALLETS CONTAINING MULTIPLE NSNS WILL NOT BE SHIPPED TO CONUS OR OCONUS DEPOTS. MULTIPLE NSN PALLET UNITS WILL HAVE STEEL STRAPPING APPLIED SIMILAR TO PALLET STRAPPING GUIDANCE CONTAINED IN THE APPLICABLE ITEM APPENDIX. ALL ITEM BOXES ON THE PALLET MUST BE RESTRAINED IN SUCH A MANNER TO PROVIDE A SAFE, SECURE, AND COMPACT PALLET UNIT FOR SHIPMENT. MULTIPLE LOT/NSN UNIT LOADS WILL BE MARKED IN ACCORDANCE WITH DAC DRAWING ACV00561.
- FF. TWO METHODS ARE APPROVED FOR DETERMINING THE AVERAGE WEIGHT THAT IS TO BE SHOWN ON PALLETIZED UNITS OF AMMUNITION THAT ARE BEING PRODUCED AT LOAD, ASSEMBLE AND PACK PLANTS.
1. PREFERRED METHOD: RANDOMLY SELECT FIVE UNIT LOADS FROM THE CURRENT MONTH'S PRODUCTION. WEIGH EACH UNIT LOAD. THE CALCULATED AVERAGE WEIGHT OF THE FIVE UNIT LOADS (TOTAL WEIGHT OF THE FIVE UNIT LOADS DIVIDED BY FIVE) WILL BE USED AS THE UNIT LOAD WEIGHT FOR WHICHEVER IS LESS, EITHER A 60-DAY PERIOD OR UNTIL A DIMENSIONAL OR CONFIGURATION CHANGE IS MADE TO THE UNIT LOAD.
  2. ALTERNATIVE METHOD: RANDOMLY SELECT AND WEIGH FIVE GROUPS OF UNIT LOAD COMPONENTS (PALLET, STRAPPING, SEALS, SPACER ASSEMBLIES, BATTENS, ETC.) FROM THE CURRENT MONTH'S PRODUCTION AND ADDING TO IT THE WEIGHT OF THE LOADED BOXES TO BE PLACED ON THE PALLET. THE WEIGHT OF THE LOADED BOXES WILL BE DETERMINED BY USING THE FOLLOWING PROCEDURES:
    - (A) WEIGH FIVE LOADED BOXES INDIVIDUALLY AND RECORD THE TOTAL WEIGHT.
    - (B) WEIGH THREE INDIVIDUAL GROUPS OF FIVE LOADED BOXES EACH AND RECORD EACH GROUP WEIGHT.
    - (C) WEIGH THREE INDIVIDUAL GROUPS OF TEN LOADED BOXES EACH AND RECORD EACH GROUP WEIGHT.
    - (D) TOTAL ALL RECORDED WEIGHTS AND DIVIDE BY 50. THE RESULT IS THE APPROVED LOADED BOX GROSS WEIGHT.THE APPROVED LOADED BOX GROSS WEIGHT WILL THEN BE MULTIPLIED BY THE QUANTITY OF BOXES TO BE PLACED ON THE PALLET AND ADDED TO EACH GROUP OF UNIT LOAD COMPONENTS. THE CALCULATED AVERAGE WEIGHT OF THE FIVE UNIT LOAD GROUPS (TOTAL WEIGHT OF THE FIVE UNIT LOAD GROUPS DIVIDED BY FIVE) WILL BE USED AS THE UNIT LOAD WEIGHT FOR WHICHEVER IS LESS, EITHER A 60-DAY PERIOD OR UNTIL A DIMENSIONAL OR CONFIGURATION CHANGE IS MADE TO THE UNIT LOAD.
- GG. WHEN UN PERFORMANCE ORIENTED PACKAGING (POP) MARKING IS REQUIRED ON BOXES, THIS MARKING WILL SHOW IN AT LEAST ONE PLACE ON THE UNITIZED LOADS.
- HH. COOLER NAILS MAY BE SUBSTITUTED FOR THE COMMON NAILS AS SPECIFIED WITHIN EACH APPENDIX BY APPLYING THE FOLLOWING GUIDANCE. THE NUMBER OF COOLER NAILS TO BE USED WILL BE THE NUMBER OF COMMON NAILS MULTIPLIED BY 1.2 AND ROUNDED UP TO THE NEXT WHOLE NUMBER. THE SIZE OF THE COOLER NAILS TO BE USED WILL BE THE SAME AS SPECIFIED FOR THE COMMON NAILS (4d, 6d, 10d, ETC.) BUT WILL CONFORM TO THE SIZE AND WEIGHT TOLERANCES SPECIFIED WITHIN ASTM F1667 FOR COOLER NAILS.
- JJ. REFER TO DAC DRAWING ACV00617 FOR APPROVED SOURCES FOR SEALLESS (CLIPLESS) SEALING TOOL. THESE APPROVED SEALING TOOLS CAN BE USED IN PLACE OF SEALS CURRENTLY SPECIFIED IN THE "MATERIAL SPECIFICATIONS" ON PAGE 2.

(CONTINUED AT RIGHT)

(GENERAL NOTES CONTINUED)

- KK. ALL NON-MANUFACTURED WOOD USED IN PALLETIZED LOAD SHALL BE HEAT TREATED AND MARKED TO SHOW CONFORMANCE TO THE INTERNATIONAL PLANT PROTECTION CONVENTION STANDARD (IPPC), ISPM-15. SEE DAC DRAWING ACV00831 FOR ISPM-15 CERTIFICATION MARKING AND PLACEMENT DETAILS.

**REVISIONS**

REVISION NO. 1, DATED MAY 1985, CONSISTS OF:

1. ADDING GENERAL NOTES "Z" AND "AA".
2. UPDATING DRAWING TO CONFORM TO CURRENT STANDARDS.

REVISION NO. 2, DATED MAY 1989, CONSISTS OF:

1. UPDATING GENERAL NOTES.
2. ADDING "TYPICAL FILLER ASSEMBLIES" DETAILS ON PAGE 8.

REVISION NO. 3, DATED JUNE 2007, CONSISTS OF:

1. UPDATING DRAWING.
2. UPDATING GENERAL NOTES.
3. CHANGING DRAWING IN ACCORDANCE WITH ECP R07K3003.

REVISION NO. 4, DATED MAY 2011, CONSISTS OF CHANGES PER ECP R07K3013 INCLUDING:

1. UPDATING GENERAL NOTES.
2. UPDATING DRAWING TO CONFORM TO CURRENT STANDARDS.

REVISION NO. 5, DATED DECEMBER 2016, CONSISTS OF CHANGES PER ECP MI-R0891 INCLUDING:

UPDATING PALLET CRITERIA IN MATERIAL SPECIFICATIONS.

REVISION NO. 6, DATED NOVEMBER 2021, CONSISTS OF CHANGES PER ECP MI-P1690R2A1 INCLUDING:

ADDING HYDRA-SPECIFIC INFORMATION TO NOTES 2 AND 5 ON PAGE 8 (PAINT AND MARKING).

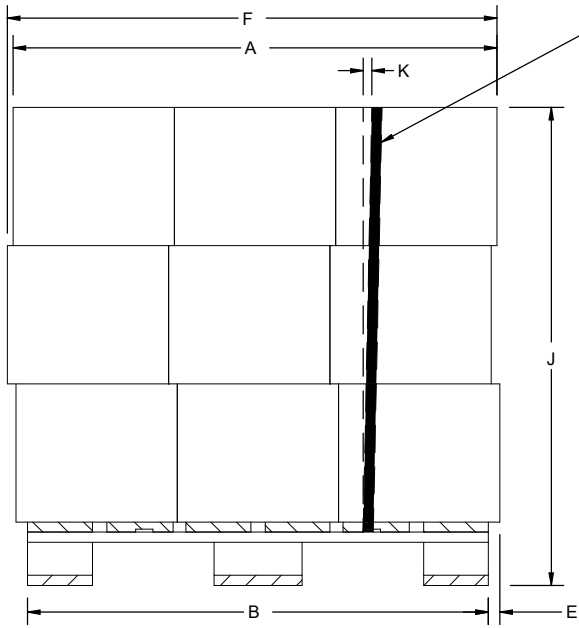

**UNIT LENGTH VIEW**

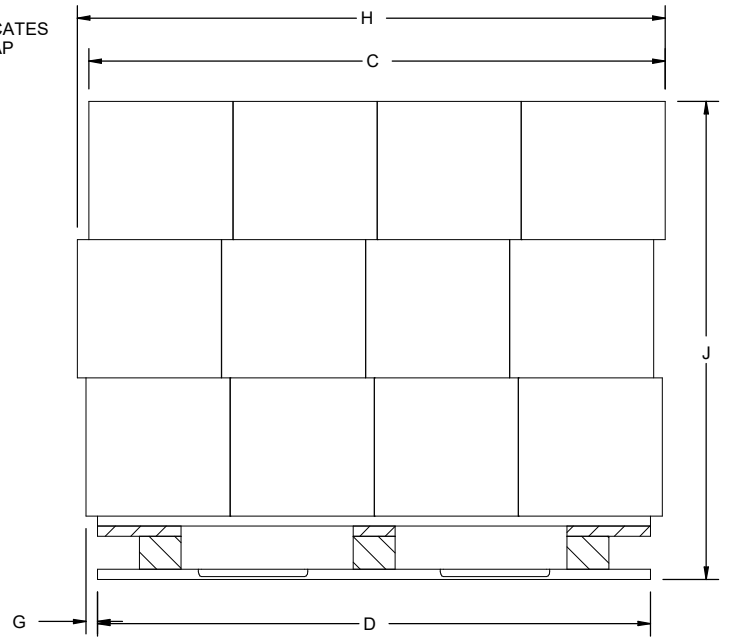

**UNIT WIDTH VIEW**

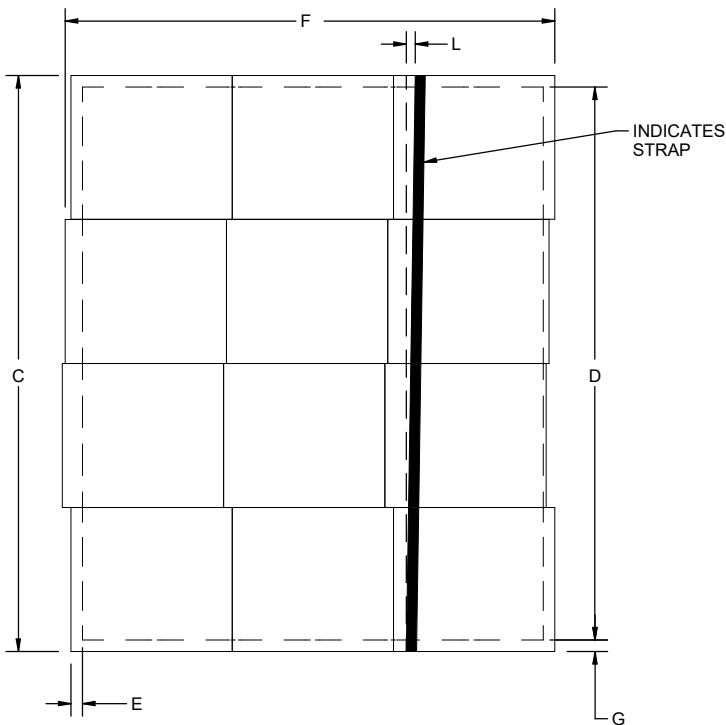

**UNIT TOP VIEW**

**SPECIAL NOTES:**

1. DIMENSIONS APPLICABLE TO ALLOWABLE TOLERANCES ARE EXPRESSED IN INCHES AND IDENTIFIED BY LETTERS AS FOLLOWS.  
 A = UNIT LENGTH  
 B = PALLET LENGTH  
 C = UNIT WIDTH  
 D = PALLET WIDTH  
 E = LENGTHWISE OVERHANG =  $(A-B) / 2$  WITH A PLUS OR MINUS 1/2" TOLERANCE FOR EACH LAYER AND FOR EACH STACK  
 F = ALLOWABLE UNIT LENGTH = "A" PLUS 1/2" MAXIMUM  
 G = WIDTHWISE OVERHANG =  $(C-D) / 2$  WITH A PLUS OR MINUS 1/2" TOLERANCE FOR EACH LAYER AND FOR EACH STACK  
 H = ALLOWABLE UNIT WIDTH = "C" PLUS 1/2" MAXIMUM  
 J = UNIT HEIGHT  
 K = VERTICAL STRAP ALIGNMENT =  $J / 40$  = MAXIMUM INCHES FROM TRUE ALIGNMENT (E.G., IF J = 50", K = 50" / 40" = 1-1/4" MAX)  
 L = TRANSVERSE STRAP ALIGNMENT =  $C / 40$  = MAXIMUM INCHES FROM TRUE ALIGNMENT (E.G., IF C = 55", L = 55" / 40" = 1-3/8" MAX)
2. BOX ALIGNMENT TOLERANCES APPLY TO EACH LAYER AND TO EACH STACK RELATIVE TO THE PALLET DECK. SEE GENERAL NOTES "G" ON PAGE 2 AND "V" ON PAGE 3.
3. STRAPPING TOLERANCES APPLY TO ALL STRAPS AND TO ALL SURFACES WHICH EACH STRAP ENCOMPASSES, I. E., TOP, BOTTOM, AND BOTH SIDES.

**ALLOWABLE TOLERANCES FOR ASSEMBLING UNITS**

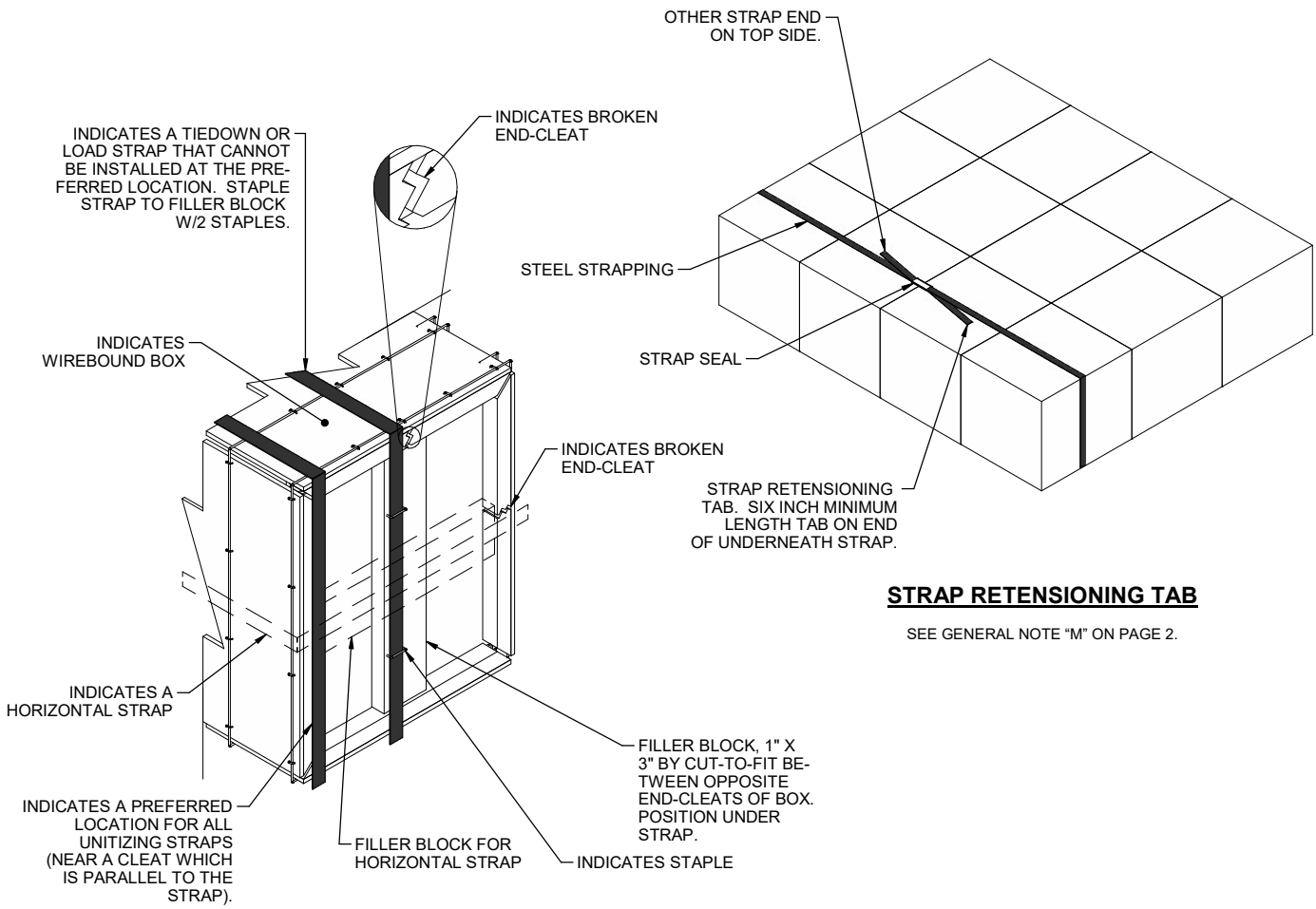

**STRAP RETENSIONING TAB**

SEE GENERAL NOTE "M" ON PAGE 2.

**SPECIAL REINFORCEMENT FOR WIREBOUND BOXES**

SEE GENERAL NOTE "Y" ON PAGE 3.

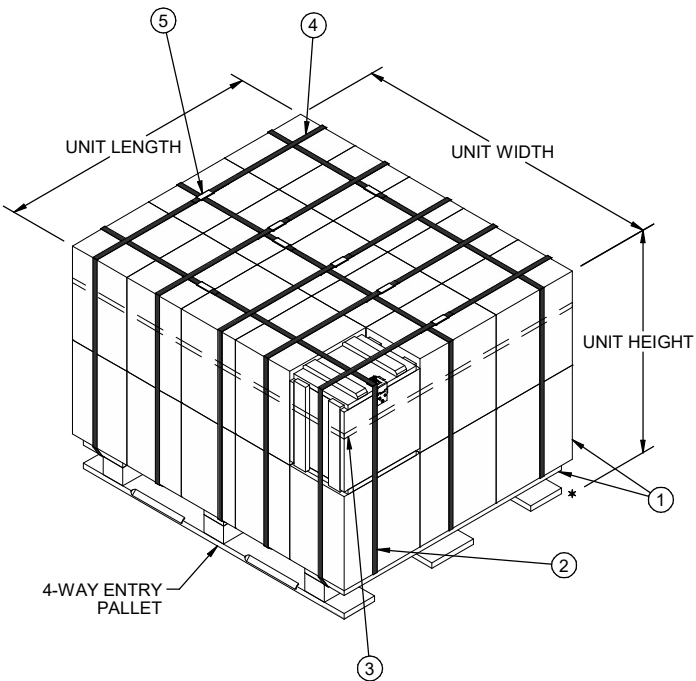

**TYPICAL PALLET UNIT**

**UNITIZATION NOTES**

- ① POSITION BOXES SO THEY ARE CENTERED LENGTHWISE AND WIDTHWISE ON THE PALLET DECK. IF BOXES ARE OF THE HINGED-TOP TYPE, THE OUTSIDE BOXES IN THE TOP LAYER WILL BE POSITIONED SO THAT THE HINGES WILL BE INWARD. SEE GENERAL NOTE "H" ON PAGE 2.
- ② LOAD STRAP, 3/4" X .035" OR .031" OR .029" BY LENGTH TO SUIT STEEL STRAPPING (AS REQD). MAY BE INSTALLED THROUGH THE STRAP SLOT OF A PALLET OR PRE-POSITIONED ON THE PALLET DECK PRIOR TO PLACING BOXES ON THE PALLET. SEE GENERAL NOTES "L" AND "M" ON PAGE 2, AND "N" ON PAGE 3. STRAPS SHALL NOT BE PLACED UNDER THE STRINGER BOARDS.
- ③ HORIZONTAL STRAP, 3/4" X .035" OR .031" OR .029" BY LENGTH TO SUIT STEEL STRAPPING (AS REQD). INSTALL STRAP TO ENCIRCLE A LAYER OF BOXES ON THE PALLET AS SHOWN. SEE GENERAL NOTES "L" AND "M" ON PAGE 2, AND "N" ON PAGE 3.
- ④ TIEDOWN STRAP, 3/4" X .035" OR .031" OR .029" BY LENGTH TO SUIT STEEL STRAPPING (AS REQD). INSTALL EACH STRAP TO PASS UNDER THE DECK BOARDS OR DECK/STRINGER BOARDS OF THE PALLET AS SHOWN. SEE GENERAL NOTES "L" AND "M" ON PAGE 2, AND "N" ON PAGE 3.
- ⑤ SEAL FOR 3/4" STRAPPING (AS REQD, 1 PER STRAP). CRIMP EACH SEAL WITH TWO PAIR OF NOTCHES. SEE GENERAL NOTE "L" ON PAGE 2.

INDICATES A CENTER STACK WITHIN THE UNIT LENGTH FOR POSITIONING ONE OR MORE FILLER ASSEMBLIES WHEN REQUIRED.

INDICATES TIEDOWN STRAP

UNIT LENGTH

UNIT WIDTH

INDICATES TYPICAL SPACER ASSEMBLY

UNIT HEIGHT

4-WAY ENTRY PALLET

INDICATES HORIZONTAL STRAP

**TYPICAL PALLET UNIT WITH ONE SPACER ASSEMBLY**

THIS VIEW DEPICTS THE APPLICATION OF A TYPICAL SPACER ASSEMBLY, POSITIONED LENGTHWISE IN THE UNIT LOAD, TO ENLARGE THE UNIT WIDTH TO SLIGHTLY OVERHANG OR TO MATCH THE WIDTH DIMENSION OF THE PALLET DECK. SIMILARLY, TO ENLARGE THE UNIT LENGTH, A SPACER ASSEMBLY WOULD BE POSITIONED WIDTHWISE IN THE LOAD. SEE GENERAL NOTES "E.3" ON PAGE 2 AND "W" ON PAGE 3.

INDICATES A CENTER STACK WITHIN THE UNIT LENGTH FOR POSITIONING ONE OR MORE FILLER ASSEMBLIES WHEN REQUIRED.

INDICATES TIEDOWN STRAP

UNIT LENGTH

UNIT WIDTH

INDICATES TYPICAL SPACER ASSEMBLY

UNIT HEIGHT

4-WAY ENTRY PALLET

INDICATES HORIZONTAL STRAP

**TYPICAL PALLET UNIT WITH THREE SPACER ASSEMBLIES**

THIS VIEW DEPICTS THE APPLICATION OF THREE TYPICAL SPACER ASSEMBLIES TO ENLARGE BOTH THE WIDTH AND THE LENGTH OF THE UNIT LOAD TO PROVIDE A SLIGHT OVERHANG ON THE PALLET OR TO MATCH THE WIDTH AND/OR LENGTH DIMENSIONS OF THE PALLET DECK. SEE GENERAL NOTES "E.3" ON PAGE 2 AND "W" ON PAGE 3.

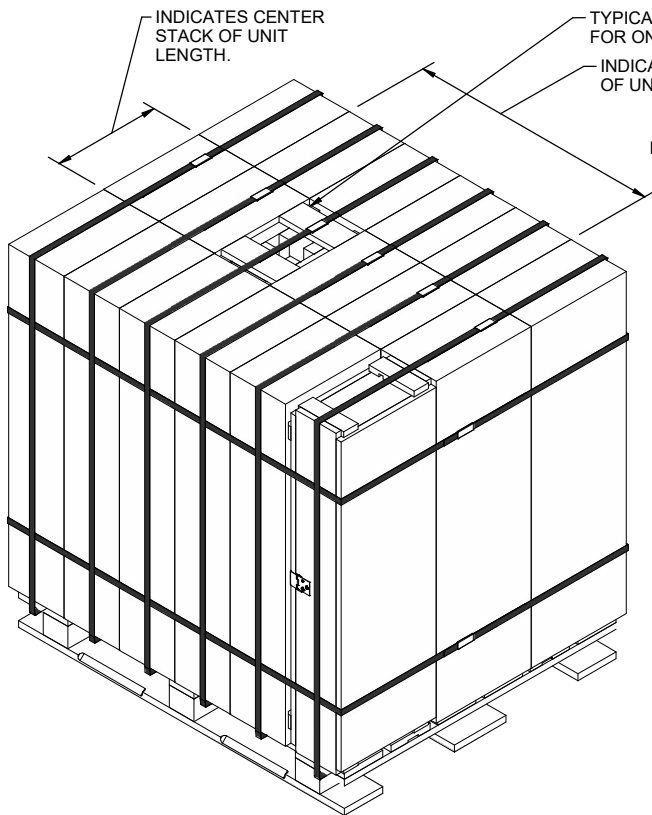

**TYPICAL APPLICATION OF FILLER**

(ONE BOX OMITTED)

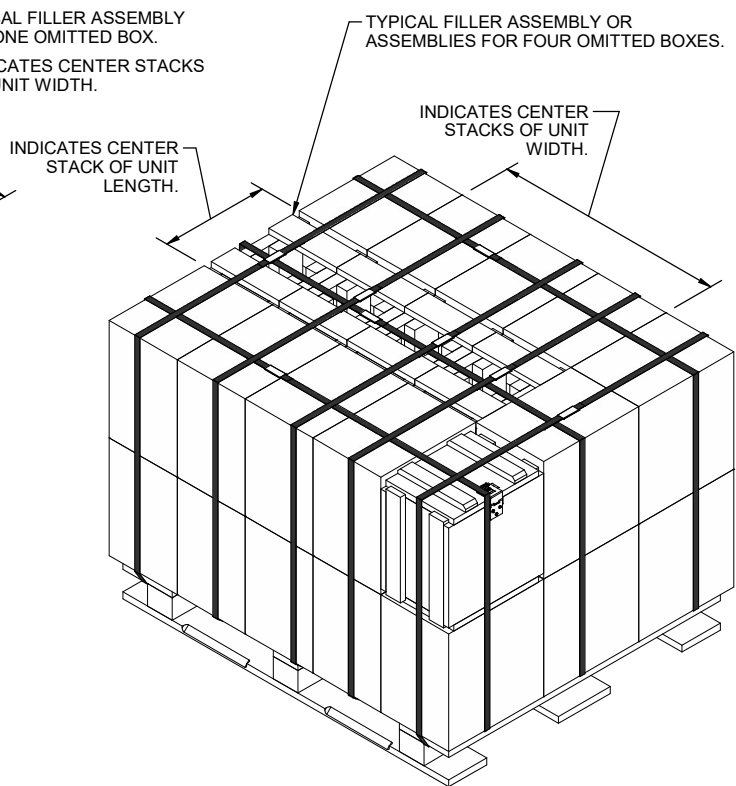

**TYPICAL APPLICATION OF FILLER**

(FOUR BOXES OMITTED)

**PROVISIONS FOR LESS-THAN-FULL-LAYER LOADS**

1. THE FOLLOWING PROVISIONS SET FORTH THE SPECIFICATIONS THAT MUST BE FOLLOWED IF A FILLER TYPE ASSEMBLY IS USED TO ACHIEVE A FULL-LAYER PALLET UNIT.
  - A. FILLERS ARE DESIGNED FOR USE IN THE PLACE OF ONE OR MORE BOXES OF A UNIT. FILLER ASSEMBLY DETAILS WILL BE DEPICTED IN THE APPENDIX APPLICABLE TO THE SPECIFIC ITEM TO BE UNITIZED. SEE GENERAL NOTE "X" ON PAGE 3 AND THE TYPICAL FILLER ASSEMBLY DETAILS ON PAGE 10.
  - B. FILLERS WILL BE POSITIONED IN THE TOP LAYER OR STACKS OF THE CENTER STACK OR STACKS WITHIN THE UNIT LENGTH OF A UNIT LOAD AS SHOWN IN THE TWO "TYPICAL APPLICATIONS OF FILLER" VIEWS ABOVE AND REFERENCED IN PALLET UNIT DETAILS ON PAGE 7. FILLERS CAN ALSO BE POSITIONED IN THE TOP LAYER OR STACKS OF THE CENTER STACK OR STACKS WITHIN THE UNIT WIDTH OF A UNIT LOAD WHEN THE QUANTITY OF FILLERS POSITIONED WITHIN THE UNIT LENGTH IS INSUFFICIENT TO SATISFY THE OMITTED-BOX QUANTITY REQUIREMENTS.
2. EMPTY BOXES, PREFERABLY "REJECTS", CAN BE USED AS FILLERS INSTEAD OF WOODEN DUNNAGE ASSEMBLIES INDICATED ABOVE, TO ACHIEVE A FULL-LAYER PALLET UNIT. HOWEVER, EMPTY BOXES WILL BE USED ONLY IN THE TOP LAYER OF A PALLET UNIT AND POSITIONED AT ANY OF THE FOUR CORNERS OF THE LAYER (NOT IN THE MIDDLE OF THE LAYER). NOT MORE THAN FOUR EMPTY BOXES MAY BE USED IN A UNIT LOAD. WHEN EMPTY BOXES ARE USED TO FILL OUT A LAYER, THE EMPTY BOXES WILL BE PAINTED AND MARKED AS SPECIFIED IN DAC DRAWING ACV00561 AND ARDEC DRAWING 12982865. FOR HYDRA-70 CONFIGURATION ONLY, PAINT AND MARK AS SPECIFIED IN AMCOM DRAWING 13643712. SEE NOTE 6 BELOW.
3. IF EMPTY WOODEN BOXES ARE USED AS FILLERS, WOOD REINFORCING BLOCKS OF 2" THICK MATERIAL BY LENGTHS REQUIRED, MAY BE POSITIONED INSIDE THE BOXES TO PREVENT THEM FROM CRUSHING OR COLLAPSING WHEN UNITIZING STRAPS ARE TENSIONED. TO HOLD THE BLOCKS IN PLACE, DRIVE 6d NAILS THROUGH THE BOX AND INTO THE ENDS OF THE REINFORCING BLOCKS. SEE THE "TYPICAL INSTALLATION OF REINFORCING BLOCKS IN AN EMPTY BOX" DETAIL ON PAGE 9.
4. IF EMPTY WIREBOUND BOXES ARE TO BE USED AS FILLERS, ONLY THOSE HAVING EMPTY RECTANGULAR METAL CONTAINERS AS INNER PACKS CAN BE USED. FILLER ASSEMBLIES MUST BE USED IN PLACE OF WIREBOUND BOXES TO SATISFY LESS-THAN-FULL-LAYER LOAD REQUIREMENTS WHEN THE INNER PACKS OF THE WIREBOUND BOXES DO NOT CONSIST OF RECTANGULAR METAL CONTAINERS.

(CONTINUED AT RIGHT)

**(PROVISIONS FOR LESS-THAN-FULL-LAYER LOADS CONTINUED)**

5. LESS THAN FULL BOXES OF AMMUNITION (LIGHT BOXES) WILL BE PAINTED AND MARKED AS SPECIFIED IN ARDEC DRAWINGS 8796522 OR 12982865. LIGHT BOXES WILL ONLY BE PLACED IN THE TOP LAYER OF A UNIT AND LOCATED AT ANY OF THE FOUR CORNERS OF THE LAYER (NOT IN THE MIDDLE OF THE LAYER). NOT MORE THAN TWO LIGHT BOXES (ONE PER LOT) WILL BE PLACED IN A UNIT LOAD. FOR HYDRA-70 CONFIGURATION ONLY, PAINT AND MARK AS SPECIFIED IN AMCOM DRAWING 13643712. SEE NOTE 6 BELOW.
6. TO SATISFY THE REQUIREMENTS FOR A FULL-LAYER UNIT, IT IS PERMISSIBLE TO USE A COMBINATION OF EMPTY AND LIGHT BOXES IN THE TOP LAYER. HOWEVER, IF A TOTAL OF FOUR EMPTY AND LIGHT BOXES DOES NOT PROVIDE FOR A FULL LAYER, ONE OR MORE FILLER ASSEMBLIES MUST BE USED IN THE MIDDLE OF THE LAYER TO ENSURE COMPLIANCE WITH THE LIMITATIONS SPECIFIED IN NOTES 2 AND/OR 5 ABOVE.
7. EACH PALLET UNIT LOAD CONTAINING EMPTY AND/OR LIGHT BOXES WILL HAVE A WEATHER RESISTANT PLACARD OR TAG PREPARED AND APPLIED TO THE UNIT LOAD AS STATED IN DAC DRAWING ACV00561.
8. EXCEPTION TO THE RULE: THIS EXCEPTION ADDRESSES THE USE OF A FILLER ASSEMBLY OR FILLER ASSEMBLIES WITHIN A UNIT LOAD TO CONSTRUCT A COMPLETE-LAYER UNIT LOAD. THE SPECIFICATIONS DELINEATED WITHIN THIS DRAWING ARE BASED ON UNIT LOADS THAT CONTAIN SEVERAL AMMUNITION PACKS WHICH ARE ARRANGED IN MULTIPLE LAYERS AND MULTIPLE STACKS ON A PALLET BASE. FOR THESE TYPES OF UNIT LOADS A FILLER OR FILLERS ARE TO BE PLACED AS SPECIFIED ELSEWHERE HEREIN, IN THE TOP LAYER OR LAYERS OF MIDDLE STACKS (NOT IN A CORNER STACK). THERE ARE, HOWEVER, MANY PALLET UNITS THAT ONLY CONTAIN ONE LAYER OF AMMUNITION PACKS, OR PALLET UNITS WHERE THE PACKS ARE ARRANGED IN ONLY TWO OR FOUR STACKS ON A PALLET BASE. THE USE OF A FILLER OR FILLERS IN THESE TYPES OF PALLET UNITS IS PERMITTED; HOWEVER, THE METHODS FOR FILLER APPLICATION WILL HAVE TO DEVIATE FROM THE BASIC RULES SPECIFIED ELSEWHERE WITHIN THIS DRAWING. THIS IS ALSO THE CASE WHEN ONLY ONE PALLET UNIT OF A SPECIFIC COMMODITY IS BEING PREPARED AND THE PALLET UNIT BEING CONSTRUCTED WILL ONLY HAVE THREE OR FEWER PACKS, WHERE NORMALLY SEVERAL PACKS ARE REQUIRED TO FILL OUT A LAYER. BASICALLY, THE PERMITTED DEVIATION FROM THE BASIC RULES GOVERNING PLACEMENT OF FILLER OR FILLERS IN A UNIT LOAD CONSISTS OF PLACING A FILLER OR FILLERS IN ONE OR MORE OF THE CORNER STACKS OF A PALLET UNIT. IF AN EMPTY "ORANGE" PACK OR PACKS ARE AVAILABLE TO FILL OUT A LAYER ON A PALLET UNIT, THE EMPTY PACK OR PACKS SHOULD BE USED IN A CORNER STACK LOCATION INSTEAD OF A FILLER ASSEMBLY. ANOTHER DEVIATION FROM THE BASIC RULES AS THEY APPLY TO USE OF FILLER ASSEMBLIES IS ALSO PERMITTED. THIS DEVIATION IS ASSOCIATED WITH SINGLE-LAYER UNIT LOADS, AND PERMITS THE USE OF FILLER ASSEMBLIES WITH TWO UNIT LOADS RATHER THAN WITHIN JUST ONE, TO ACHIEVE SOUND AND EFFECTIVE UNIT LOADS. SPECIFIC GUIDANCE RELATIVE TO THE USE OF THIS LATTER DEVIATION IS SET FORTH IN APPLICABLE INDIVIDUAL APPENDICES THAT AUGMENT THIS BASIC PROCEDURES DRAWING.



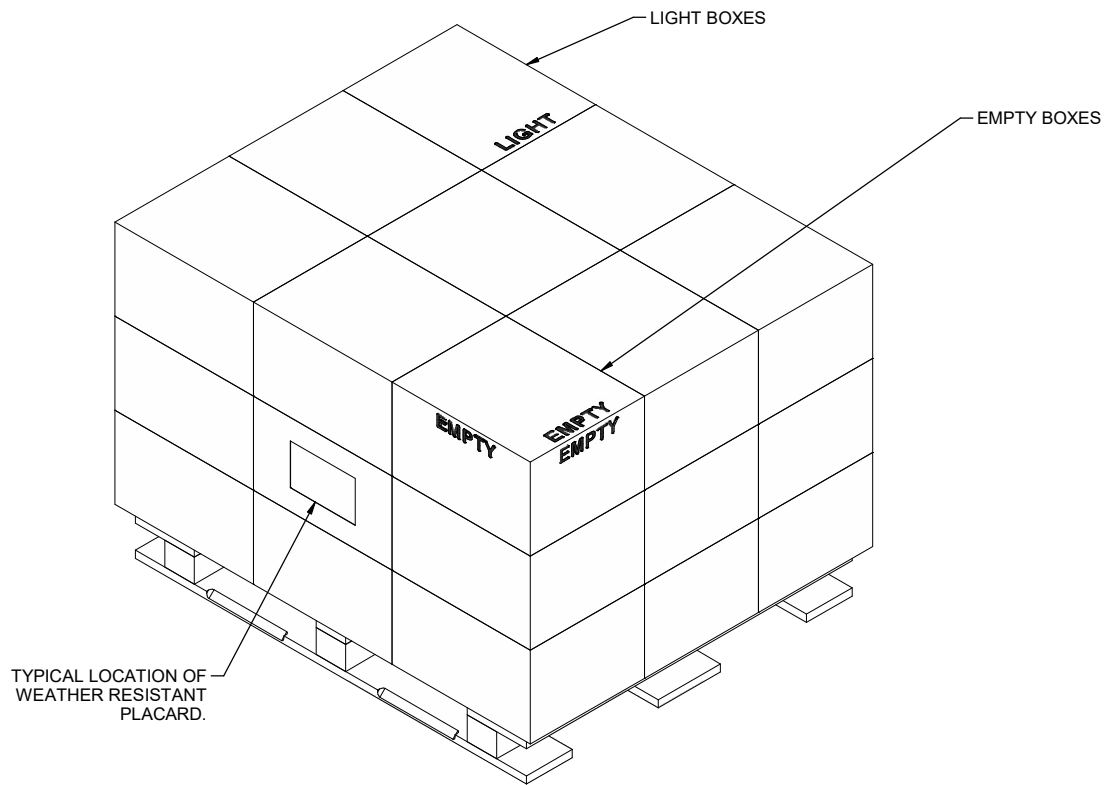

**USE OF EMPTY/LIGHT BOXES TO ACHIEVE A FULL LAYER**

UNITIZING STRAPS HAVE BEEN OMITTED FROM THE DETAIL ABOVE FOR CLARITY PURPOSES.

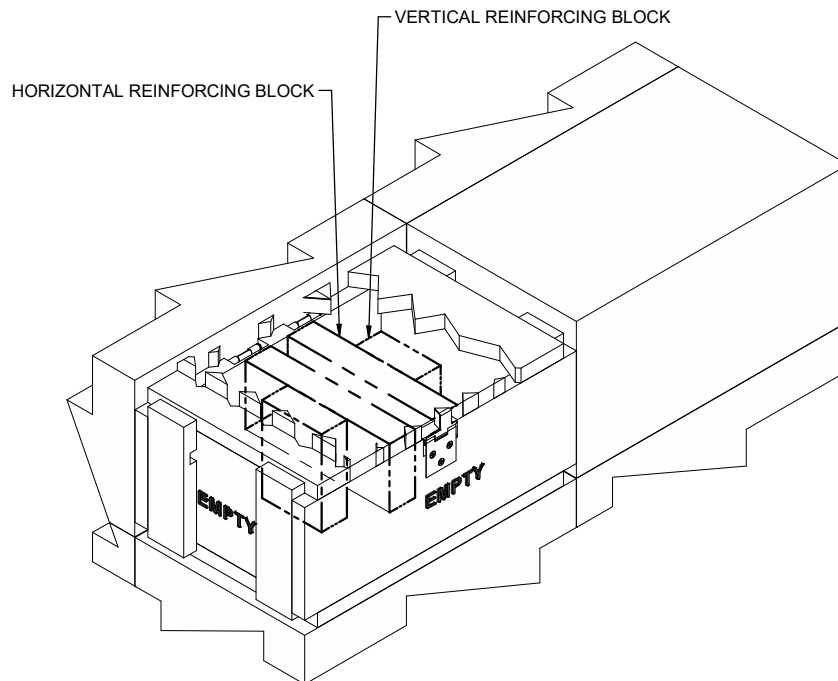

**TYPICAL INSTALLATION OF REINFORCING BLOCKS IN AN EMPTY BOX**

UNITIZING STRAPS HAVE BEEN OMITTED FROM THE DETAIL ABOVE FOR CLARITY PURPOSES.

**LESS-THAN-FULL-LAYER UNIT LOADS**

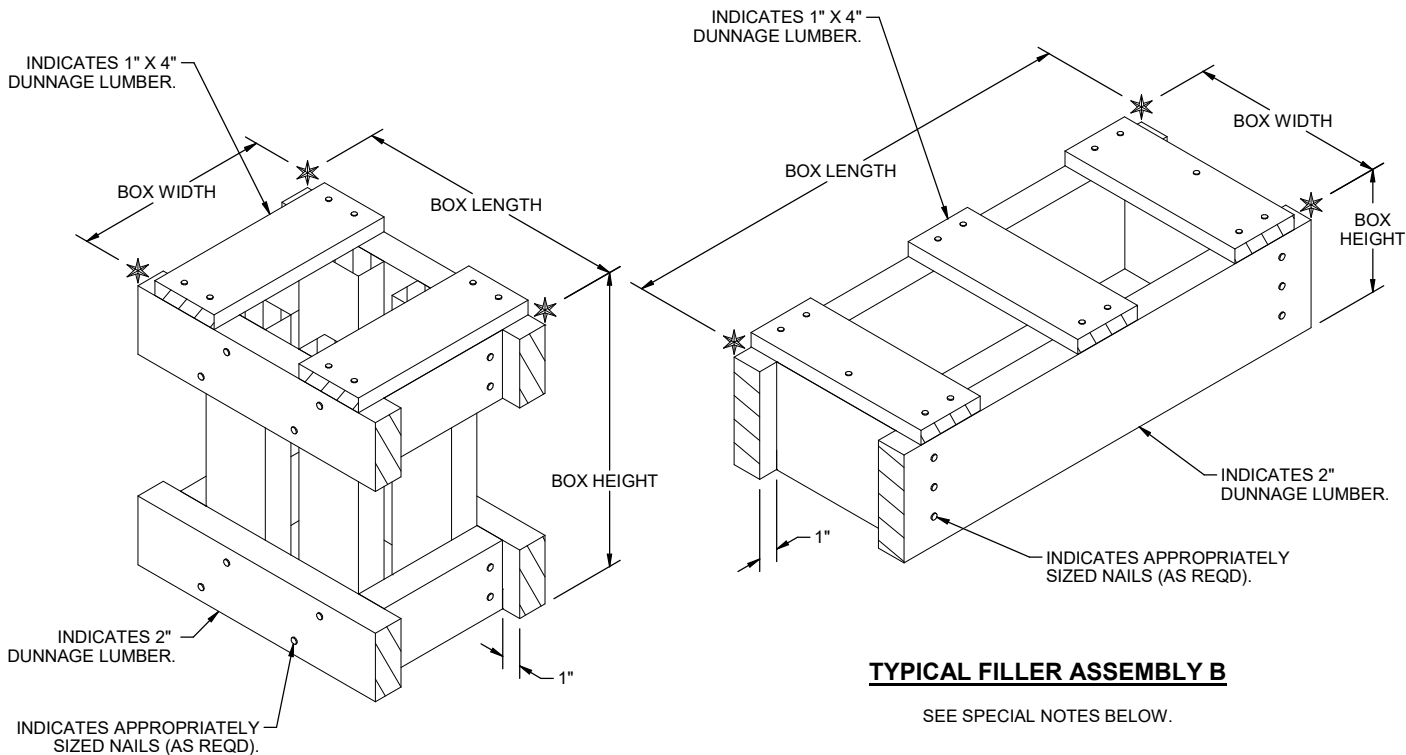

**TYPICAL FILLER ASSEMBLY A**

SEE SPECIAL NOTES BELOW.

**TYPICAL FILLER ASSEMBLY B**

SEE SPECIAL NOTES BELOW.

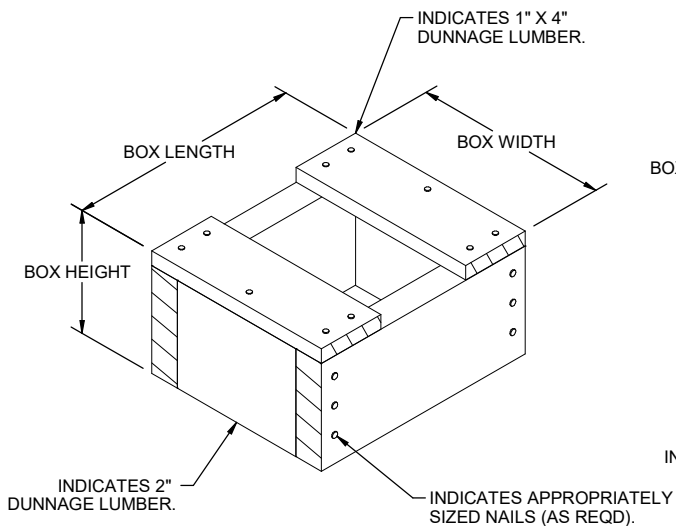

**TYPICAL FILLER ASSEMBLY C**

SEE SPECIAL NOTES BELOW.

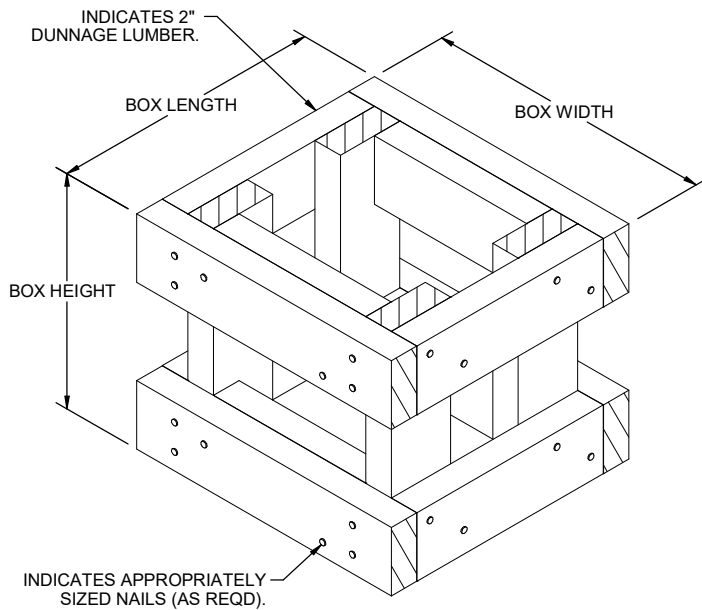

**TYPICAL FILLER ASSEMBLY D**

SEE SPECIAL NOTES BELOW.

**SPECIAL NOTES:**

1. TYPICAL FILLER ASSEMBLIES "A" AND "B" ARE TYPICAL OF THE ASSEMBLIES USED TO REPLACE CLEATED WOODEN BOXES, AND TYPICAL FILLER ASSEMBLIES "C" AND "D" ARE TYPICAL OF THE ASSEMBLIES USED TO REPLACE WIREBOUND BOXES. THE DECISION OF WHICH FILLER ASSEMBLY TO USE WILL BE BASED UPON MATERIAL AVAILABILITY AND CONSTRUCTION ECONOMICS.
2. FILLER ASSEMBLIES MUST BE ASSEMBLED WITHIN ALLOWABLE TOLERANCES. SEE GENERAL NOTE "J" ON PAGE 2.
3. SEE THE APPLICABLE APPENDIX TO DETERMINE THE RECOMMENDED FILLER ASSEMBLY FOR A PARTICULAR ITEM. SEE GENERAL NOTE "X" ON PAGE 3.