

APPENDIX 9

UNITIZATION PROCEDURES FOR BOXED WHITE PHOSPHORUS (WP) AND PLASTICIZED WHITE PHOSPHORUS (PWP) LOADED AMMUNITION ON 4-WAY ENTRY PALLETS

GRENADE, HAND, PACKED 16 PER WOODEN BOX,
UNITIZED 36 BOXES PER 35" X 45½" PALLET;
APPROX BOX SIZE 15½" L X 12¼" W X 7½" H

PALLET UNIT DATA						
ITEMS INCLUDED		HAZARD CLASSIFICATION ①				WEIGHT
NSN	DODIC	DOT CLASS	CG CLASS	QD CLASS	COMP GROUP	(LBS)
1330-00-676-2671	G937	A	II-D	(08) 1.2	H	1,295

REVISION

REVISION NO. 1, DATED MAY 1986, CONSISTS OF:

1. CHANGING BOX DIMENSIONS.
2. UPDATING PALLET UNIT TO CONFORM TO 1. ABOVE.

NOTICE: THIS APPENDIX CANNOT STAND ALONE BUT MUST BE USED IN CONJUNCTION WITH THE BASIC UNITIZATION PROCEDURES DRAWING 19-48-4015-20PA1004.

① HAZARD CLASSIFICATION DATA CONTAINED IN THE ABOVE CHART IS FOR GUIDANCE AND INFORMATIONAL PURPOSES ONLY. VERIFICATION OF THE SPECIFIED DATA SHOULD BE MADE BY CONSULTING THE MOST RECENT JOINT HAZARD CLASSIFICATION SYSTEM LISTING OR OTHER APPROVED LISTING (S).

DO NOT SCALE

REVISIONS				DATE	BY	FOR
1	MAY 86	WRF	WRF	JIC	WRF	WRF
APPROVED, U. S. ARMY ARMAMENT MATERIEL READINESS COMMAND						
APPROVED BY CHIEF OF COMMAND GENERAL, U. S. ARMY MATERIEL DEVELOPMENT AND READINESS COMMAND						
U. S. ARMY DARCOM DRAWING						
MARCH 1983						
CLASS	DIVISION	DRAWING	FILE			
19	48	4015/9	20PA 1004			

GENERAL NOTES

- A. THIS APPENDIX CANNOT STAND ALONE BUT MUST BE USED IN CONJUNCTION WITH THE BASIC UNITIZATION PROCEDURES DRAWING 19-48-4015-20PA1004, TO PRODUCE AN APPROVED UNIT LOAD, ALL PERTINENT PROCEDURES, SPECIFICATIONS AND CRITERIA SET FORTH WITHIN THE BASIC DRAWING WILL APPLY TO THE PROCEDURES DELINEATED IN THIS APPENDIX. ANY EXCEPTIONS TO THE BASIC PROCEDURES ARE SPECIFIED IN THIS APPENDIX.
- B. DIMENSIONS, CUBE AND WEIGHT OF A PALLET UNIT WILL VARY SLIGHTLY DEPENDING UPON THE ACTUAL DIMENSIONS OF THE BOXES AND THE WEIGHT OF THE SPECIFIC ITEM BEING UNITIZED.
- C. THE LOAD STRAPS WILL BE PRE-POSITIONED ON THE PALLET DECK PRIOR TO PLACING BOXES ON THE PALLET. LOAD STRAPS WILL NOT BE TENSIONED AND SEALED UNTIL AFTER TIEDOWN STRAPS HAVE BEEN TENSIONED AND SEALED.
- D. INSTALL EACH TIEDOWN STRAP TO PASS UNDER THE TOP DECK BOARDS OF THE PALLET AND TO BE LOCATED AS SHOWN. TIEDOWN STRAPS WILL BE TENSIONED AND SEALED PRIOR TO LOAD STRAPS.
- E. THE FOLLOWING AMC (DARCOM) DRAWINGS ARE APPLICABLE FOR OUTLOADING AND STORAGE OF THE ITEMS COVERED BY THIS APPENDIX.
 - CARLOADING — DRAWING 19-48-4115-5PA1002
 - TRUCKLOADING — DRAWING 19-48-4117-11PA1003
 - STORAGE — DRAWING 19-48-4118-1-2-3-4-14-22PA1002
- F. FOR METHOD OF SECURING A STRAP CUTTER TO THE PALLET UNIT, SEE DARCOM DRAWING 19-48-4127-20P1000.
- G. IF ITEMS COVERED HEREIN ARE UNITIZED PRIOR TO ISSUANCE OF THIS APPENDIX, THE BOXES NEED NOT BE REUNITIZED SOLELY TO CONFORM TO THIS APPENDIX.
- H. THE UNITIZATION PROCEDURES DEPICTED HEREIN MAY ALSO BE USED FOR UNITIZING GRENADES WHEN IDENTIFIED BY DIFFERENT NATIONAL STOCK NUMBERS (NSN) THAN WHAT IS SHOWN ON THE TITLE PAGE, PROVIDED THE BOX PACK DOES NOT VARY FROM WHAT IS DELINEATED HEREIN. THE EXPLOSIVE CLASSIFICATION OF OTHER ITEMS MAY BE DIFFERENT THAN WHAT IS SHOWN.

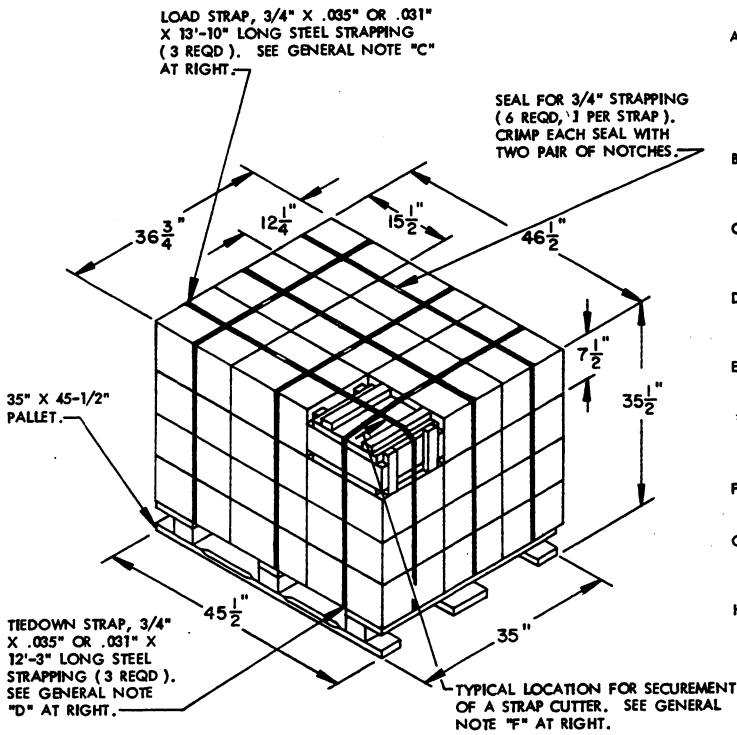

PALLET UNIT

SEE GENERAL NOTE "B" AT RIGHT.

36 BOXES OF GRENADES (16 PER BOX) @ 34 LBS	1,224 LBS (APPROX)
DUNNAGE	6 LBS
PALLET	65 LBS
TOTAL WEIGHT	1,295 LBS (APPROX)
CUBE	35.1 CU FT (APPROX)

BILL OF MATERIAL

PALLET, 35" X 45-1/2"	1 REQD	65 LBS
STEEL STRAPPING, 3/4"	78.25' REQD	5.59 LBS
SEAL FOR 3/4" STRAPPING	6 REQD	NIL

TIE PIECE, 1" X 4" X BOX WIDTH (2 REQD.). NAIL TO LONGITUDINAL PIECES W/2-6d NAILS AT EACH END AND NAIL TO LATERAL PIECE W/1-6d NAIL.

VERTICAL PIECE, 2" X 4" X BOX HEIGHT MINUS 3/4" (4 REQD.).

