

APPENDIX 7A

UNITIZATION PROCEDURES FOR BOXED WHITE PHOSPHORUS (WP) AND PLASTICIZED WHITE PHOSPHORUS (PWP) LOADED AMMUNITION ON 4-WAY ENTRY PALLET

CARTRIDGE, 105MM, PACKED 2 PER WOODEN BOX,
UNITIZED 18 BOXES PER 40" X 48" PALLET; APPROX
BOX SIZE 43½" L X 14" W X 8½" H

| PALLET UNIT DATA | | | | | | |
|------------------|-------|------------------------------------|----------|----------|------------|--------|
| ITEMS INCLUDED | | HAZARD CLASSIFICATION ^① | | | | WEIGHT |
| NSN | DODIC | DOT CLASS | CG CLASS | QD CLASS | COMP GROUP | (LBS) |
| 1315-00-143-7183 | C512 | A | II-D | (12) 1.2 | H | 2,556 |
| 00-901-4921 | C512 | A | II-D | (12) 1.2 | H | 2,556 |

NOTICE: THIS APPENDIX CANNOT STAND ALONE BUT MUST BE USED IN CONJUNCTION WITH THE BASIC UNITIZATION PROCEDURES DRAWING 19-48-4015-20PA1004.

① HAZARD CLASSIFICATION DATA CONTAINED IN THE ABOVE CHART IS FOR GUIDANCE AND INFORMATIONAL PURPOSES ONLY. VERIFICATION OF THE SPECIFIED DATA SHOULD BE MADE BY CONSULTING THE MOST RECENT JOINT HAZARD CLASSIFICATION SYSTEM LISTING OR OTHER APPROVED LISTING(S).

DO NOT SCALE

| REVISIONS | | | | DRAFTSMAN <i>GW</i> | PROJ ENG <i>bh</i> |
|--|----------|-------------|---------------------|------------------------|--|
| | | | | CHECKER <i>GRG</i> | LOG ENGRG OFFICE <i>W. E. Emate</i> |
| APPROVED, U.S. ARMY ARMAMENT, MUNITIONS AND CHEMICAL COMMAND | | | | | |
| | | | <i>D. M. Carter</i> | | <i>S. J. Boyd</i> |
| | | | DRSIC - LEP (R) | | DRSIC - TRD (R) |
| APPROVED BY ORDER OF COMMANDING GENERAL, U.S. ARMY MATERIEL DEVELOPMENT AND READINESS COMMAND (DARCOM) | | | | | |
| <i>John J. Boyd</i> | | | | | |
| U.S. ARMY DEFENSE AMMUNITION CENTER AND SCHOOL | | | | | |
| U. S. ARMY DARCOM DRAWING | | | | | |
| APRIL 1984 | | | | | |
| CLASS | DIVISION | DRAWING | FILE | | |
| 19 | 48 | 4015/ 7A | 20 PA 1004 | | |

HORIZONTAL STRAP, 3/4" X .035" OR .031" X 17'-8" LONG STEEL STRAPPING (2 REQD). SEE GENERAL NOTE "D" AT RIGHT.

TIEDOWN STRAP, 3/4" X .035" OR .031" X 15'-4" LONG STEEL STRAPPING (6 REQD). SEE GENERAL NOTE "C" AT RIGHT.

SEAL FOR 3/4" STRAPPING (8 REQD, 1 PER STRAP). CRIMP EACH SEAL WITH TWO PAIR OF NOTCHES.

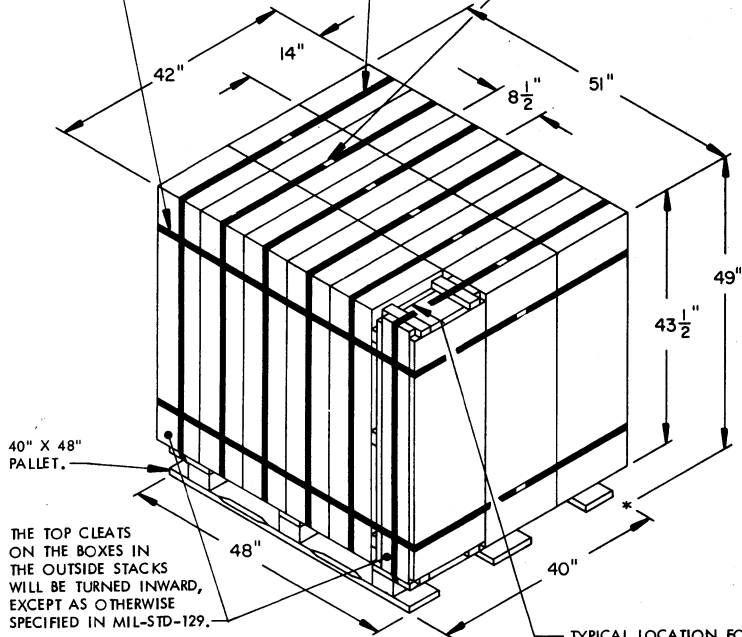

PALLET UNIT

SEE GENERAL NOTE "B" AT RIGHT.

18 BOXES OF 105MM CARTRIDGES (2 PER BOX) @ 137 LBS ----- 2,466 LBS (APPROX)
 DUNNAGE ----- 10 LBS
 PALLET ----- 80 LBS

TOTAL WEIGHT ----- 2,556 LBS (APPROX)
 CUBE ----- 60.3 CU FT (APPROX)

BILL OF MATERIAL

| | | |
|-------------------------------|--------------------|----------|
| PALLET, 40" X 48" ----- | 1 REQD ----- | 80 LBS |
| STEEL STRAPPING, 3/4" ----- | 127.33' REQD ----- | 9.10 LBS |
| SEAL FOR 3/4" STRAPPING ----- | 8 REQD ----- | NIL |

TIE PIECE, 1" X 4" X BOX HEIGHT (2 REQD). NAIL TO LATERAL PIECES W/1-6d NAIL AT EACH END AND TO LONGITUDINAL PIECE W/3-6d NAILS.

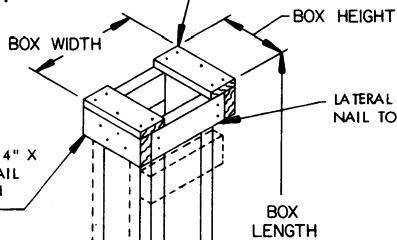

LONGITUDINAL PIECE, 2" X 4" X BOX HEIGHT (4 REQD). NAIL TO VERTICAL PIECE W/4-10d NAILS.

LATERAL PIECE, 2" X 4" X BOX WIDTH MINUS 3" (4 REQD). NAIL TO VERTICAL PIECES W/2-10d NAILS AT EACH END.

FILL PIECE, 2" X 6" X CUT-TO-FIT (1 REQD). NAIL TO THE VERTICAL PIECE W/3-10d NAILS. NOTE: WHEN A UNIT HAS MORE THAN 6 BOXES OMITTED THE FILLER ASSEMBLY OR ASSEMBLIES LOCATED IN AN OUTER STACK ON THE 48" SIDE OR SIDES OF THE PALLET WILL REQUIRE A "FILL PIECE" AS SHOWN.

VERTICAL PIECE, 2" X 6" BY BOX LENGTH MINUS 3/4" (2 REQD).

STRAP BEARING PIECE, 2" X 4" X BOX WIDTH MINUS 3" (2 REQD). NAIL TO VERTICAL PIECES W/2-10d NAILS AT EACH END. NOTE: WHEN A UNIT HAS MORE THAN 12 BOXES OMITTED, THE FILLER ASSEMBLY OR ASSEMBLIES LOCATED IN AN OUTER STACK ON THE 40" SIDE OR SIDES OF THE PALLET WILL REQUIRE "STRAP BEARING PIECES" AS SHOWN. STAPLE STRAPS TO "STRAP BEARING PIECES".

FILLER ASSEMBLY

(FOR MINUS ONE BOX)

GENERAL NOTES

- A. THIS APPENDIX CANNOT STAND ALONE BUT MUST BE USED IN CONJUNCTION WITH THE BASIC UNITIZATION PROCEDURES DRAWING 19-48-4015-20PA1004. TO PRODUCE AN APPROVED UNIT LOAD, ALL PERTINENT PROCEDURES, SPECIFICATIONS AND CRITERIA SET FORTH WITHIN THE BASIC DRAWING WILL APPLY TO THE PROCEDURES DELINEATED IN THIS APPENDIX. ANY EXCEPTIONS TO THE BASIC PROCEDURES ARE SPECIFIED IN THIS APPENDIX.
- B. DIMENSIONS, CUBE AND WEIGHT OF A PALLET UNIT WILL VARY SLIGHTLY DEPENDING UPON THE ACTUAL DIMENSIONS OF THE BOXES AND THE WEIGHT OF THE SPECIFIC ITEM BEING UNITIZED.
- C. INSTALL EACH TIEDOWN STRAP TO PASS UNDER THE TOP DECK/STRINGER BOARDS OF THE PALLET AND BE LOCATED AS SHOWN. TIEDOWN STRAPS WILL BE APPLIED BUT NOT TENSIONED UNTIL THE HORIZONTAL STRAPS HAVE BEEN TENSIONED AND SEALED.
- D. INSTALL EACH HORIZONTAL STRAP TO ENIRCLE THE LAYER OF BOXES ON THE PALLET. HORIZONTAL STRAPS MUST BE TENSIONED AND SEALED PRIOR TO TENSIONING OF TIEDOWN STRAPS.
- E. THE FOLLOWING DARCOM DRAWINGS ARE APPLICABLE FOR OUTLOADING AND STORAGE OF THE ITEMS COVERED BY THIS APPENDIX.
 CARLOADING-----DRAWING 19-48-4115-5PA1002
 TRUCKLOADING-----DRAWING 19-48-4117-11PA1003
 STORAGE-----DRAWING 19-48-4118-1-2-3-4-14-22PA1002
- F. FOR METHOD OF SECURING A STRAP CUTTER TO THE PALLET UNIT, SEE DARCOM DRAWING 19-48-4127-20P1000.
- G. IF ITEMS COVERED HEREIN ARE UNITIZED PRIOR TO ISSUANCE OF THIS APPENDIX, THE BOXES NEED NOT BE REUNITIZED SOLELY TO CONFORM TO THIS APPENDIX.
- H. THE UNITIZATION PROCEDURES DEPICTED HEREIN MAY ALSO BE USED FOR UNITIZING 105MM CARTRIDGES WHEN IDENTIFIED BY DIFFERENT NATIONAL STOCK NUMBERS (NSN) THAN WHAT IS SHOWN ON THE TITLE PAGE, PROVIDED THE BOX PACK DOES NOT VARY FROM WHAT IS DELINEATED HEREIN. THE EXPLOSIVE CLASSIFICATION OF OTHER ITEMS MAY BE DIFFERENT THAN WHAT IS SHOWN.