

# APPENDIX 5D

## UNITIZATION PROCEDURES FOR BOXED WHITE PHOSPHORUS (WP) AND PLASTICIZED WHITE PHOSPHORUS (PWP) LOADED AMMUNITION ON 4-WAY ENTRY PALLETS

CARTRIDGE, 81MM, PACKED 3 PER WIREBOUND BOX  
UNITIZED 32 BOXES PER 42" X 53" PALLET;  
APPROX BOX SIZE 25 $\frac{1}{8}$ " L X 13 $\frac{3}{8}$ " W X 5 $\frac{5}{16}$ " H

PALLET UNIT DATA						
ITEMS INCLUDED		HAZARD CLASSIFICATION <sup>①</sup>				WEIGHT (LBS)
NSN	DODIC	DOT CLASS	CG CLASS	QD CLASS	COMP GROUP	
1315-00-574-7680	C276	A	II-D	(12) 1.2	H	1,568

### REVISIONS

REVISION NO. 1, DATED OCTOBER 1985, CONSISTS OF:

1. CHANGING BOX TYPE.
2. MODIFYING PALLET UNIT TO CONFORM TO 1 ABOVE.

REVISION NO. 2, DATED JULY 1986, CONSISTS OF:

DELETING ITEM BY NATIONAL STOCK NUMBER (NSN) FROM "PALLET UNIT DATA" CHART.

**NOTICE:** THIS APPENDIX CANNOT STAND ALONE BUT MUST BE USED IN CONJUNCTION WITH THE BASIC UNITIZATION PROCEDURES DRAWING 19-48-4015-20PA1004.

<sup>①</sup> HAZARD CLASSIFICATION DATA CONTAINED IN THE ABOVE CHART IS FOR GUIDANCE AND INFORMATIONAL PURPOSES ONLY. VERIFICATION OF THE SPECIFIED DATA SHOULD BE MADE BY CONSULTING THE MOST RECENT JOINT HAZARD CLASSIFICATION SYSTEM LISTING OR OTHER APPROVED LISTING (S).

**DO NOT SCALE**

REVISIONS		DRAWN BY	PROJ ENG	NO. (1/2)
1	OCT 85	<i>W. J. E. / W. J. E.</i>	<i>LAF / W. J. E.</i>	
2	JUL 86	<i>W. J. E. / W. J. E.</i>	<i>W. J. E. / W. J. E.</i>	
		APPROVED BY GROUP OF COMMANDERS, U.S. ARMY AMMUNITION CENTER AND SCHOOL		
		APPROVED BY GROUP OF COMMANDERS, U.S. ARMY AMMUNITION CENTER AND SCHOOL		
		U.S. ARMY AMC DRAWING		
		JUNE 1985		
		CLASS	DIVISION	DRAWING
		19	48	4015/ 5D
				FILE
				20PA 1004

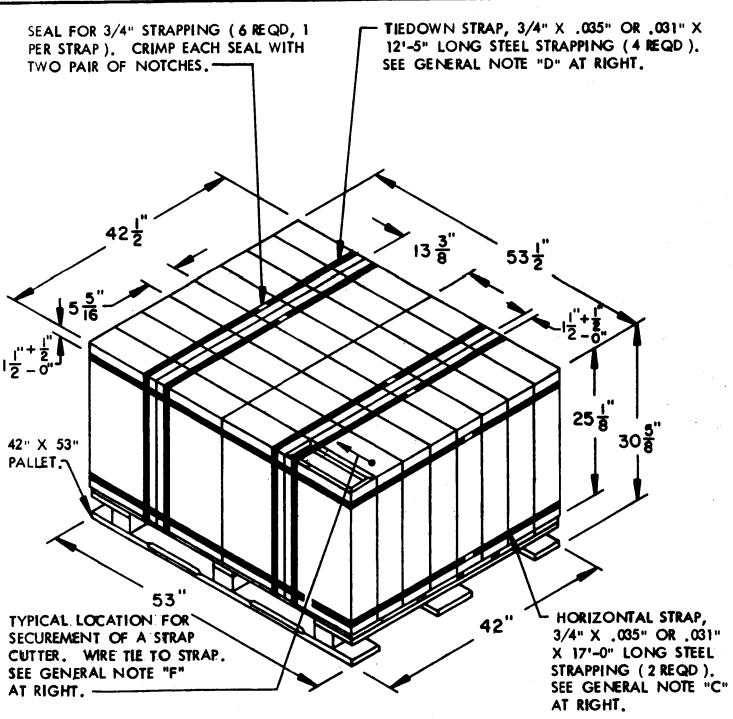

**PALLET UNIT**

SEE GENERAL NOTE "B" AT RIGHT.

32 BOXES OF 81MM CARTRIDGES (3 PER BOX)	46 LBS	1,472 LBS (APPROX)
DUNNAGE	6 LBS	
PALLET	90 LBS	
TOTAL WEIGHT		1,568 LBS (APPROX)
CUBE		40.3 CU FT (APPROX)

**BILL OF MATERIAL**

PALLET, 42" X 53"	1 REQD	90 LBS
STEEL STRAPPING, 3/4"	83.67 REQD	5.98 LBS
SEAL FOR 3/4" STRAPPING	6 REQD	NIL

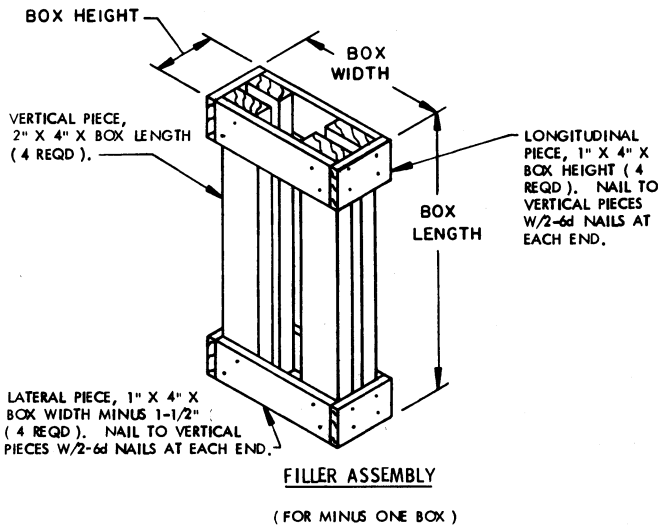

**FILLER ASSEMBLY**

(FOR MINUS ONE BOX)

**GENERAL NOTES**

- A. THIS APPENDIX CANNOT STAND ALONE BUT MUST BE USED IN CONJUNCTION WITH THE BASIC UNITIZATION PROCEDURES DRAWING 19-48-4015-20PA1004. TO PRODUCE AN APPROVED UNIT LOAD, ALL PERTINENT PROCEDURES, SPECIFICATIONS AND CRITERIA SET FORTH WITHIN THE BASIC DRAWING WILL APPLY TO THE PROCEDURES DELINEATED IN THIS APPENDIX. ANY EXCEPTIONS TO THE BASIC PROCEDURES ARE SPECIFIED IN THIS APPENDIX.
- B. DIMENSIONS, CUBE AND WEIGHT OF A PALLET UNIT WILL VARY SLIGHTLY DEPENDING UPON THE ACTUAL DIMENSIONS OF THE BOXES AND THE WEIGHT OF THE SPECIFIC ITEM BEING UNITIZED.
- C. INSTALL THE HORIZONTAL STRAP TO ENCIRCLE THE LAYER OF BOXES ON THE PALLET. NOTE THAT THE STRAPS WILL BE LOCATED AS DIMENSIONED, NEAR THE EDGE OF THE BOX. HORIZONTAL STRAP MUST BE TENSIONED AND SEALED PRIOR TO APPLICATION OF TIEDOWN STRAPS.
- D. INSTALL EACH TIEDOWN STRAP TO PASS UNDER THE TOP DECK BOARDS OF THE PALLET AND TO BE LOCATED AS SHOWN. NOTE THAT THE STRAPS WILL BE LOCATED AS DIMENSIONED. TIEDOWN STRAPS WILL NOT BE APPLIED UNTIL THE HORIZONTAL STRAPS HAVE BEEN TENSIONED AND SEALED.
- E. THE FOLLOWING AMC (DARCOM) DRAWINGS ARE APPLICABLE FOR OUTLOADING AND STORAGE OF THE ITEMS COVERED BY THIS APPENDIX.  
 CARLOADING-----DRAWING 19-48-4115-5PA1002  
 TRUCKLOADING-----DRAWING 19-48-4117-11PA1003  
 STORAGE-----DRAWING 19-48-4118-1-2-3-4-14-22PA1002
- F. FOR METHOD OF SECURING A STRAP CUTTER TO THE PALLET UNIT, SEE DARCOM DRAWING 19-48-4127-20P1000.
- G. IF ITEMS COVERED HEREIN ARE UNITIZED PRIOR TO ISSUANCE OF THIS APPENDIX, THE BOXES NEED NOT BE REUNITIZED SOLELY TO CONFORM TO THIS APPENDIX.
- H. THE UNITIZATION PROCEDURES DEPICTED HEREIN MAY ALSO BE USED FOR UNITIZING 81MM CARTRIDGES WHEN IDENTIFIED BY DIFFERENT NATIONAL STOCK NUMBERS (NSN) THAN WHAT IS SHOWN ON THE TITLE PAGE, PROVIDED THE BOX PACK DOES NOT VARY FROM WHAT IS DELINEATED HEREIN. THE EXPLOSIVE CLASSIFICATION OF OTHER ITEMS MAY BE DIFFERENT THAN WHAT IS SHOWN.
- J. IF THERE IS A NEED TO USE FILLER ASSEMBLIES AND AT LEAST TWO PALLET UNITS ARE BEING CONSTRUCTED, NOT MORE THAN 28 FILLERS WILL BE INSTALLED IN ANY ONE PALLET UNIT. ADDITIONAL FILLERS CAN BE PLACED IN A SECOND PALLET UNIT AS REQUIRED WHEN THE QUANTITY OF 28 FILLERS IN THE FIRST REDUCED PALLET UNIT IS INSUFFICIENT TO SATISFY THE TOTAL REDUCTION NEEDED. USING TWO PALLET UNITS TO SATISFY THE PALLETIZATION CRITERIA APPLICABLE TO LESS-THAN-FULL PALLET UNITS IS AN EXCEPTION TO THE BASIC PROCEDURES. HOWEVER, THE EXCEPTION IS NECESSARY FOR THE AMMUNITION PACK COVERED BY THIS APPENDIX, TO MOST EFFECTIVELY GET AN ACCEPTABLE, COMPACT AND SOUND PALLET UNIT.
- K. THE STYLE 1B PALLET DELINEATED IN THE DETAIL AT LEFT NEED NOT HAVE CHAMFERS OR STRAP SLOTS AS SPECIFIED IN MILITARY SPECIFICATION MIL-P-15011 WHEN USED FOR THE UNITIZATION OF THE ITEMS COVERED BY THIS APPENDIX.