

APPENDIX 3B

UNITIZATION PROCEDURES FOR BOXED WHITE PHOSPHORUS (WP) AND PLASTICIZED WHITE PHOSPHORUS (PWP) LOADED AMMUNITION ON 4-WAY ENTRY PALLETS

CARTRIDGE, 75MM, PACKED 2 PER WOODEN BOX,
UNITIZED 20 BOXES PER 35" X 45 $\frac{1}{2}$ " PALLET;
APPROX BOX SIZE 34 $\frac{1}{8}$ " L X 11 $\frac{1}{2}$ " W X 7 $\frac{1}{4}$ " H

PALLET UNIT DATA						
ITEMS INCLUDED		HAZARD CLASSIFICATION				WEIGHT (LBS)
NSN	DODIC	DOT CLASS	CG CLASS	QD CLASS	COMP GROUP	
1315- 00-028-4649	C056	A	II-D	(12) 1. 2	H	1, 690
00-028-4650	C056	A	II-D	(12) 1. 2	H	1, 550

NOTICE: THIS APPENDIX CANNOT STAND ALONE BUT MUST BE USED
IN CONJUNCTION WITH THE BASIC UNITIZATION PROCEDURES DRAWING
19-48-4015-20PA1004.

REVISIONS				DRAFTSMAN <i>Dier</i> / pt	PROJ ENG <i>WRE/llm</i>
				CHECKER <i>GRS</i>	LOG ENGRG OFFICE <i>W. G. G. G.</i>
				APPROVED, U. S. ARMY ARMAMENT MATERIEL READINESS COMMAND	
				<i>W. G. G. G.</i> DRBAR - LEP DRBAR - LEP	
				APPROVED BY ORDER OF COMMANDING GENERAL, U. S. ARMY MATERIEL DEVELOPMENT AND READINESS COMMAND (DARCOM)	
				<i>John L. Sargent</i> U. S. ARMY DEFENSE AMMUNITION CENTER AND SCHOOL	
U. S. ARMY DARCOM DRAWING					
FEBRUARY 1983					
				CLASS	DIVISION
				DRAWING	FILE
				19	48
				4015/ 3B	20PA 1004

DO NOT SCALE

GENERAL NOTES

- A. THIS APPENDIX CANNOT STAND ALONE BUT MUST BE USED IN CONJUNCTION WITH THE BASIC UNITIZATION PROCEDURES DRAWING 19-48-4015-20PA1004. TO PRODUCE AN APPROVED UNIT LOAD, ALL PERTINENT PROCEDURES, SPECIFICATIONS AND CRITERIA SET FORTH WITHIN THE BASIC DRAWING WILL APPLY TO THE PROCEDURES DELINEATED IN THIS APPENDIX. ANY EXCEPTIONS TO THE BASIC PROCEDURES ARE SPECIFIED IN THIS APPENDIX.
- B. DIMENSIONS, CUBE AND WEIGHT OF A PALLET UNIT WILL VARY SLIGHTLY DEPENDING UPON THE ACTUAL DIMENSIONS OF THE BOXES AND THE WEIGHT OF THE SPECIFIC ITEM BEING UNITIZED.
- C. INSTALL THE HORIZONTAL STRAP TO ENCIRCLE THE LAYER OF BOXES ON THE PALLET. HORIZONTAL STRAP MUST BE TENSIONED AND SEALED PRIOR TO APPLICATION OF TIEDOWN STRAPS.
- D. INSTALL EACH TIEDOWN STRAP TO PASS UNDER THE DECK/STRINGER BOARDS OF THE PALLET AND TO BE LOCATED AS SHOWN. TIEDOWN STRAPS WILL NOT BE APPLIED UNTIL THE HORIZONTAL STRAP HAS BEEN TENSIONED AND SEALED.
- E. THE FOLLOWING DARCOM DRAWINGS ARE APPLICABLE FOR OUT-LOADING AND STORAGE OF THE ITEMS COVERED BY THIS APPENDIX.
 CARLOADING-----DRAWING 19-48-4115-5PA1002
 TRUCKLOADING-----DRAWING 19-48-4117-11PA1003
 STORAGE-----DRAWING 19-48-4118-1-2-3-4-14-22PA1002
- F. FOR METHOD OF SECURING A STRAP CUTTER TO THE PALLET UNIT, SEE DARCOM DRAWING 19-48-4127-20P1000.
- G. IF ITEMS COVERED HEREIN ARE UNITIZED PRIOR TO ISSUANCE OF THIS APPENDIX, THE BOXES NEED NOT BE REUNITIZED SOLELY TO CONFORM TO THIS APPENDIX.
- H. THE UNITIZATION PROCEDURES DEPICTED HEREIN MAY ALSO BE USED FOR UNITIZING 75MM CARTRIDGES WHEN IDENTIFIED BY DIFFERENT NATIONAL STOCK NUMBERS (NSN) THAN WHAT IS SHOWN ON THE TITLE PAGE, PROVIDED THE BOX PACK DOES NOT VARY FROM WHAT IS DELINEATED HEREIN. THE EXPLOSIVE CLASSIFICATION OF OTHER ITEMS MAY BE DIFFERENT THAN WHAT IS SHOWN.
- J. IF THERE IS A NEED TO USE FILLER ASSEMBLIES AND AT LEAST TWO PALLET UNITS ARE BEING CONSTRUCTED, NOT MORE THAN 16 FILLERS WILL BE INSTALLED IN ANY ONE PALLET UNIT. ADDITIONAL FILLERS CAN BE PUT IN A SECOND PALLET UNIT AS REQUIRED WHEN THE QUANTITY OF 16 FILLERS IN THE FIRST REDUCED PALLET UNIT IS INSUFFICIENT TO SATISFY THE TOTAL REDUCTION NEEDED. USING TWO PALLET UNITS TO SATISFY THE PALLETIZATION CRITERIA APPLICABLE TO LESS-THAN-FULL PALLET UNITS IS AN EXCEPTION TO THE BASIC PROCEDURES. HOWEVER, THE EXCEPTION IS NECESSARY FOR THE AMMUNITION PACK COVERED BY THIS APPENDIX, TO MOST EFFECTIVELY GET AN ACCEPTABLE, COMPACT AND SOUND PALLET UNIT.

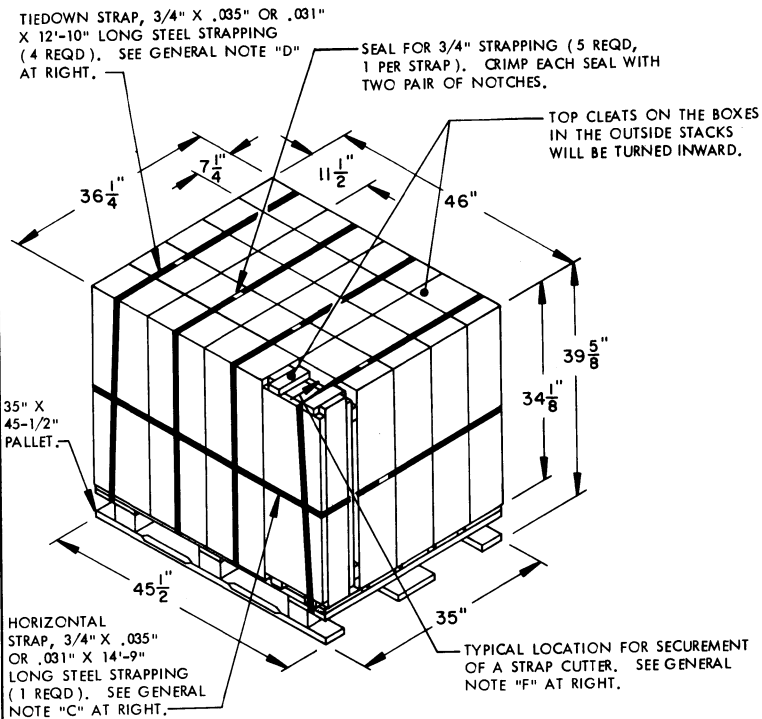

PALLET UNIT

SEE GENERAL NOTE "B" AT RIGHT.

20 BOXES OF 75MM CARTRIDGES (2 PER BOX) @ 81 LBS	-----1,620 LBS (APPROX)
DUNNAGE	-----5 LBS
PALLET	-----65 LBS
TOTAL WEIGHT	-----1,690 LBS (APPROX)
CUBE	-----38.2 CU FT (APPROX)

BILL OF MATERIAL

PALLET, 35" X 45-1/2"	-----1 REQD	-----65 LBS
STEEL STRAPPING, 3/4"	-----66.08' REQD	-----4.72 LBS
SEAL FOR 3/4" STRAPPING	-----5 REQD	-----NIL

TIE PIECE, 1" X 4" X BOX HEIGHT (2 REQD). NAIL TO LONGITUDINAL PIECES W/2-6d NAILS AT EACH END AND TO LATERAL PIECE W/1-6d NAIL.

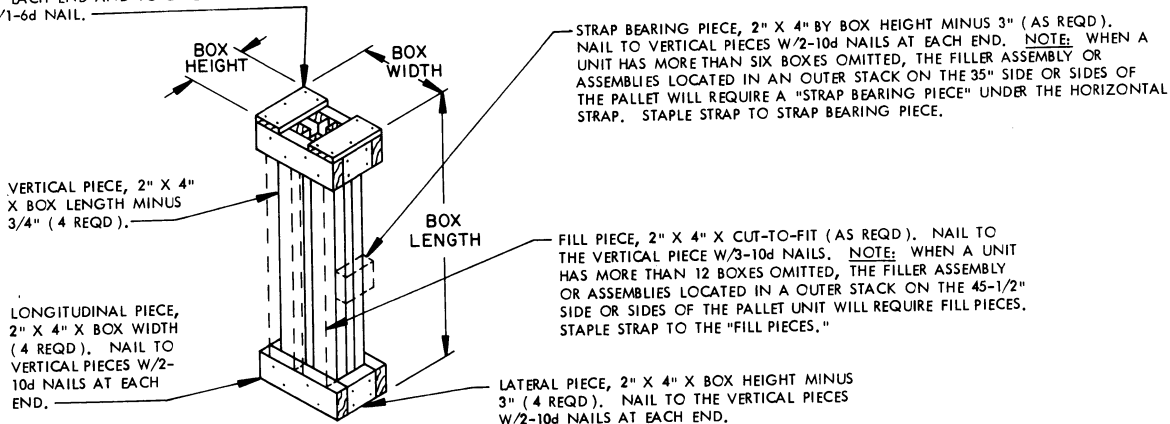

FILLER ASSEMBLY

(FOR MINUS ONE BOX)