

# APPENDIX 2A

## UNITIZATION PROCEDURES FOR BOXED WHITE PHOSPHORUS (WP) AND PLASTICIZED WHITE PHOSPHORUS (PWP) LOADED AMMUNITION ON 4-WAY ENTRY PALLETS

CARTRIDGE, 60MM, PACKED 8 PER WOODEN BOX,  
UNITIZED 60 BOXES PER 40" X 48" PALLET;  
APPROX BOX SIZE  $14\frac{5}{8}$ " L X  $10\frac{1}{8}$ " W X  $6\frac{7}{8}$ " H

PALLET UNIT DATA						
ITEMS INCLUDED		HAZARD CLASSIFICATION				WEIGHT (LBS)
NSN	DOD IC	DOT CLASS	CG CLASS	QD CLASS	COMP GROUP	
1310- 00-782-5517	B630	A	II-D	(12) 1. 2	H	3, 027

NOTICE: THIS APPENDIX CANNOT STAND ALONE BUT MUST BE USED  
IN CONJUNCTION WITH THE BASIC UNITIZATION PROCEDURES DRAWING  
19-48-4015-20PA1004.

REVISIONS				DRAFTSMAN <i>LN</i> / pt	PROJ ENG <i>WRF/MW</i>
				CHECKER <i>GRG</i>	LOG ENGRG OFFICE <i>W. J. Smith</i>
APPROVED, U. S. ARMY ARMAMENT MATERIEL READINESS COMMAND					
<i>W. J. Smith</i> DARSAN/THD DARSAN/THD					
APPROVED BY ORDER OF COMMANDING GENERAL, U. S. ARMY MATERIEL DEVELOPMENT AND READINESS COMMAND (DARCOM)					
<i>John X. Byrd</i> U. S. ARMY DEFENSE AMMUNITION CENTER AND SCHOOL					
<b>U. S. ARMY DARCOM DRAWING</b>					
<b>FEBRUARY 1983</b>					
CLASS	DIVISION	DRAWING	FILE		
<b>19</b>	<b>48</b>	<b>4015/2A</b>	<b>20PA 1004</b>		

**DO NOT SCALE**

**GENERAL NOTES**

- A. THIS APPENDIX CANNOT STAND ALONE BUT MUST BE USED IN CONJUNCTION WITH THE BASIC UNITIZATION PROCEDURES DRAWING 19-48-4015-20PA1004. TO PRODUCE AN APPROVED UNIT LOAD, ALL PERTINENT PROCEDURES, SPECIFICATIONS AND CRITERIA SET FORTH WITHIN THE BASIC DRAWING WILL APPLY TO THE PROCEDURES DELINEATED IN THIS APPENDIX. ANY EXCEPTIONS TO THE BASIC PROCEDURES ARE SPECIFIED IN THIS APPENDIX.
- B. DIMENSIONS, CUBE AND WEIGHT OF A PALLET UNIT WILL VARY SLIGHTLY DEPENDING UPON THE ACTUAL DIMENSIONS OF THE BOXES AND THE WEIGHT OF THE SPECIFIC ITEM BEING UNITIZED.
- C. INSTALL EACH HORIZONTAL STRAP TO ENIRCLE A LAYER OF BOXES ON THE PALLET. HORIZONTAL STRAPS MUST BE TENSIONED AND SEALED PRIOR TO APPLICATION OF TIEDOWN STRAPS.
- D. INSTALL EACH TIEDOWN STRAP TO PASS UNDER THE DECK/STRINGER BOARDS OF THE PALLET AND TO BE LOCATED AS SHOWN. TIEDOWN STRAPS WILL NOT BE APPLIED UNTIL THE HORIZONTAL STRAPS HAVE BEEN TENSIONED AND SEALED.
- E. THE FOLLOWING DARCOM DRAWINGS ARE APPLICABLE FOR UNLOADING AND STORAGE OF THE ITEMS COVERED BY THIS APPENDIX.  
 CARLOADING-----DRAWING 19-48-4115-5PA1002  
 TRUCKLOADING-----DRAWING 19-48-4117-11PA1003  
 STORAGE-----DRAWING 19-48-4118-1-2-3-4-14-22PA1002
- F. FOR METHOD OF SECURING A STRAP CUTTER TO THE PALLET UNIT, SEE DARCOM DRAWING 19-48-4127-20P1000.
- G. IF ITEMS COVERED HEREIN ARE UNITIZED PRIOR TO ISSUANCE OF THIS APPENDIX, THE BOXES NEED NOT BE REUNITIZED SOLELY TO CONFORM TO THIS APPENDIX.
- H. THE UNITIZATION PROCEDURES DEPICTED HEREIN MAY ALSO BE USED FOR UNITIZING 60MM CARTRIDGES, WHEN IDENTIFIED BY DIFFERENT NATIONAL STOCK NUMBERS (NSN) THAN WHAT IS SHOWN ON THE TITLE PAGE, PROVIDED THE BOX PACK DOES NOT VARY FROM WHAT IS DELINEATED HEREIN. THE EXPLOSIVE CLASSIFICATION OF OTHER ITEMS MAY BE DIFFERENT THAN WHAT IS SHOWN.

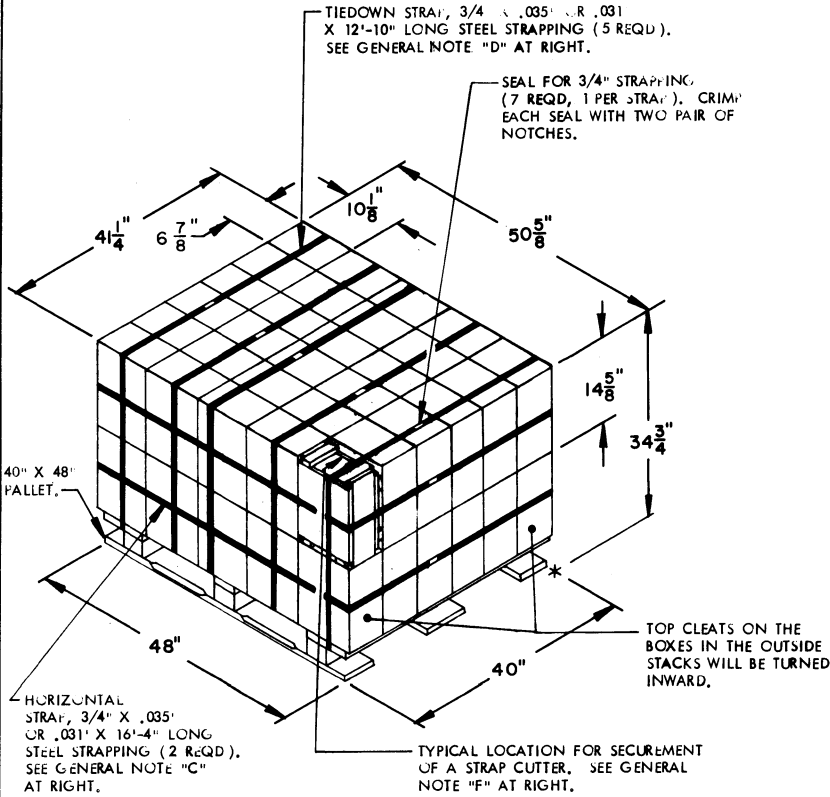

**PALLET UNIT**

SEE GENERAL NOTE "B" AT RIGHT.

60 BOXES OF 60MM CARTRIDGES (8 PER BOX) @ 49 LBS-----	2,940 LBS (APPROX)
DUNNAGE-----	7 LBS
PALLET-----	80 LBS
TOTAL WEIGHT-----	3,027 LBS (APPROX)
CUBE-----	42.0 CU FT (APPROX)

**BILL OF MATERIAL**

PALLET, 40" X 48"-----	1 REQD-----	80 LBS
STEEL STRAPPING, 3/4"-----	96.83' REQD-----	6.92 LBS
SEAL FOR 3/4" STRAPPING-----	7 REQD-----	NIL

TIE PIECE, 1" X 4" X BOX HEIGHT (2 REQD). NAIL TO LONGITUDINAL PIECES W/2-6d NAILS AT EACH END AND TO LATERAL PIECE W/1-6d NAIL.

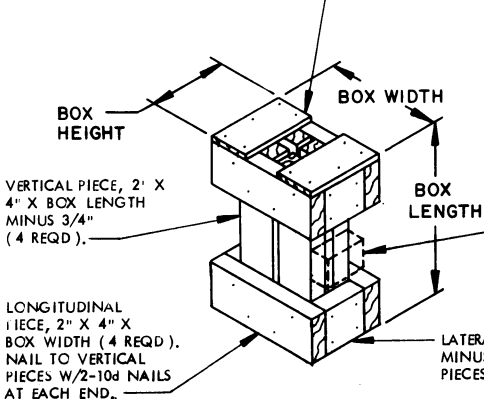

STRAP BEARING PIECE, 2" X 4" X BOX HEIGHT MINUS 3" (AS REQD). NAIL TO VERTICAL PIECES W/2-10d NAILS AT EACH END. NOTE: WHEN A UNIT HAS MORE THAN 24 BOXES OMITTED, THE FILLER ASSEMBLY OR ASSEMBLIES LOCATED IN AN OUTER STACK ON THE 40" SIDE OR SIDES OF THE PALLET WILL REQUIRE A "STRAP BEARING PIECE" UNDER THE HORIZONTAL STRAP. STAPLE STRAP TO "STRAP BEARING PIECE".