



STORAGE OF BOMBS IN IGLOO MAGAZINES

INDEX

PAGE	2	GENERAL NOTES
	3-22A	PLANS, ELEVATIONS, ETC.
	23-27	TABULAR STORAGE DATA

BOMB	PAGE(S)	BOMB	PAGE(S)
4 LB, FRAG	23	4000 LB, LC	25
90 LB, FRAG	23	10000 LB, DEMO	25
220 LB, FRAG	23	12000 LB, GP	25
260 LB, FRAG	23	500 LB, SAP	26
100 LB, GP	23 & 27	1000 LB, SAP	26
250 LB, GP	23	2000 LB, SAP	26
500 LB, GP	24	250 LB, T.I.	26 & 27
1000 LB, GP	24	500 LB, CLUSTER FRAG.	27
2000 LB, GP	25	150 LB, PHOTOFLASH	27
3000 LB, DEMO.	25 & 27	750 LB, DEMO.	27

INDEX TO FSN AND DOD
IDENTIFICATION CODE 28 & 29

CAUTION

GENERAL NOTES PAGE 2 WILL
BE THOROUGHLY READ PRIOR
TO STORAGE OPERATIONS.

STORAGE OF BOMBS IN IGLOO MAGAZINES			
D'YBMAN <i>KRM/RJH</i>	TRACER	ENGINEER <i>CRJ/ABC</i>	SUBMITTED <i>[Signature]</i>
CHECKER <i>CRJ</i>	CHECKER <i>ABC</i>	ENGINEER <i>ABC</i>	ORD. CORPS U.S.A.
REVISIONS			EXAMINED <i>[Signature]</i>
1	10-12-55	<i>CRJ</i>	ORD. CORPS U.S.A.
2	7-12-56	<i>RAS CRJ</i>	APPROVED BY ORDER OF THE CHIEF OF ORDNANCE <i>[Signature]</i>
			ASSISTANT ORD. CORPS U.S.A.
ORDNANCE CORPS U.S.A.			
30 November 1953			
CLASS	DIVISION	DRAWING	FILE
19	48	4006	1B1000

GENERAL NOTES

1. METHODS OF STORAGE SHOWN HEREIN PROVIDES FOR MAGAZINES WITH EXPLOSIVE LIMITS OF 250,000LBS.* ACTUAL NUMBER OF BOMBS STORED WILL BE CONTROLLED BY AMOUNT SHOWN IN TABULAR DATA. (*EXCEPTION: 10,000 LB BOMB, -SEE PGS 22A & 25.
2. IN THE EVENT IGLOOS ARE PROVIDED WITH CONCRETE APRONS OR OTHER HARD STANDING SURFACE OF SUFFICIENT SIZE ALLOWING HANDLING EQUIPMENT TO ENTER IGLOO IN A FORWARD POSITION, TYPE "A" STACKS AS SHOWN HEREIN MAY BE STORED THROUGHOUT MAGAZINES PROVIDED EXPLOSIVE LIMIT IS NOT EXCEEDED. EXPLOSIVE LIMIT PER MAGAZINE MAY EXCEED 250,000LBS ONLY ON SPECIFIC AUTHORITY FROM OFFICE, CHIEF OF ORDNANCE.
3. STORAGE OF BOMBS WITH AND WITHOUT SHIPPING BANDS IS SHOWN HEREIN HOWEVER, STORAGE OF BOMBS WITH SHIPPING BANDS IN PLACE IS AUTHORIZED ONLY FOR BOMBS WHICH ARE IN SERVICEABLE CONDITION SUCH AS NEWLY PRODUCED BOMBS OR THOSE RECENTLY HAVING UNDERGONE NORMAL MAINTENANCE AND ON WHICH THE BANDS ARE DRY.
4. IN ORDER TO OBTAIN CAPACITY STORAGE, ANY AISLE OR STACK LIMITING DIMENSION THAT DOES NOT HAVE A SPECIFIED TOLERANCE MAY BE ADJUSTED TO SUIT LOCAL CONDITIONS.
5. IN MANY INSTANCES, STEEL BOMB DUNNAGE-ORD CORPS DWG. 13-48-307-1B20- IS REFERRED TO. HOWEVER, THIS TYPE DUNNAGE WILL BE USED ONLY IF IMMEDIATELY AVAILABLE TO THE STORING INSTALLATION.
6. METHODS SHOWN HEREIN ALLOW FOR STORAGE BY MEANS OF CONVEYOR OR FORK LIFT TRUCK.
7. THE FOLLOWING MATERIAL SPECIFICATIONS SHALL APPLY TO THIS DRAWING:

LUMBER: SEE PARA. 5400, ORDM3-4, VOL. 2, 15 APRIL, 1956
 STRAPPING: TYPE I, CLASS B, FED. SPEC. QQ-S-781A
 NAILS: COMMON, CEMENT COATED, FED. SPEC. FF-N-101
 ALT. NAILS: ANNULARLY GROOVED NAILS OF SAME SIZE.

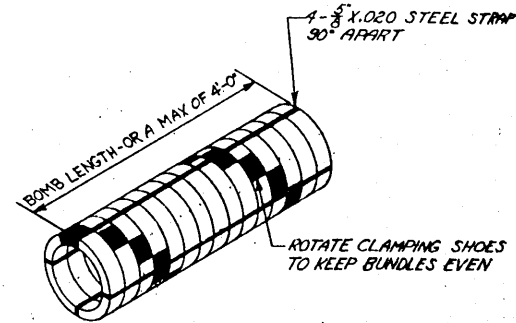

DETAIL - METHOD OF BUNDLING SHIPPING BANDS

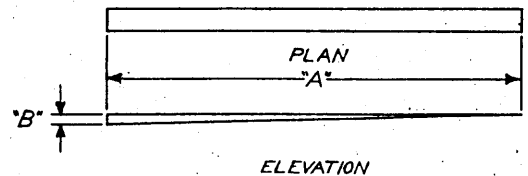

WEDGE DETAIL

2"x4" MATERIAL
 (2"x6" MATL. FOR 10,000 & 12,000 LB. BOMBS,
 AND FOR CLUSTER FRAG. BOMB, 500 LB)

WEDGE DIMENSIONS	DIM. "A" - 6'-0"	DIM. "B" - 1"
	DIM. "A" - 9'-0"	DIM. "B" - 1 5/8"

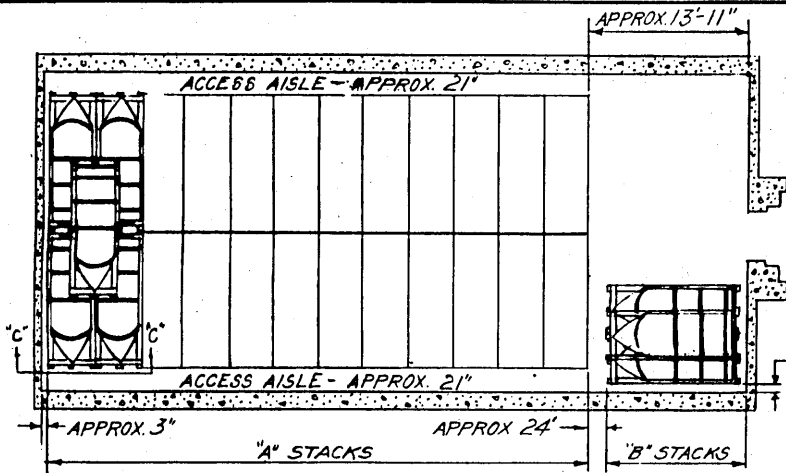

FLOOR PLAN-60' IGL00

4 RAILS 6" X 6" X 6' 1" AT REAR OF IGL00 ONLY. ALL OTHER RAILS 47" LONG.

REAR OF IGL00

WEDGES

SECTION "C-C"

NOTE:

FOR PACKING & MARKING OF PALLET SEE DWG. NO. 76-18-29.

NOTE:

THIS METHOD OF STORAGE IS ONLY PERMISSIBLE WHERE SUITABLE M.H.E IS AVAILABLE.

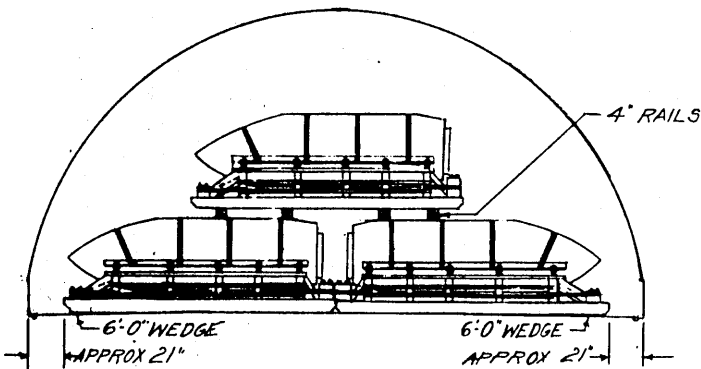

STACK "A" ELEVATION

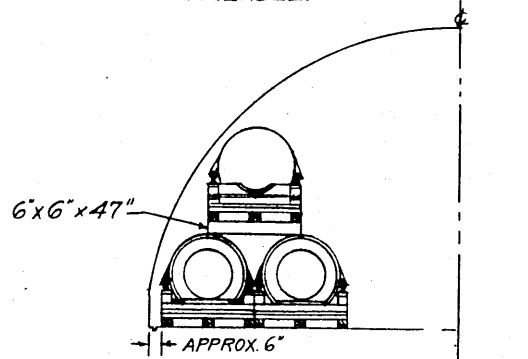

FRONT STACKING FOR 60' IGL00 (STACK "B")

BOMB, 12,000 LBS.

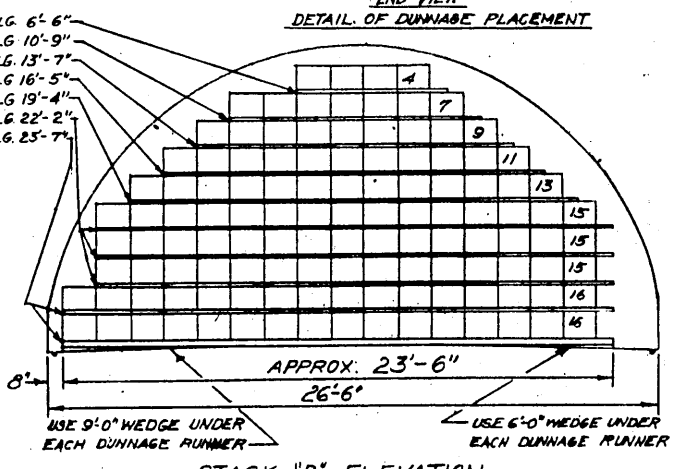
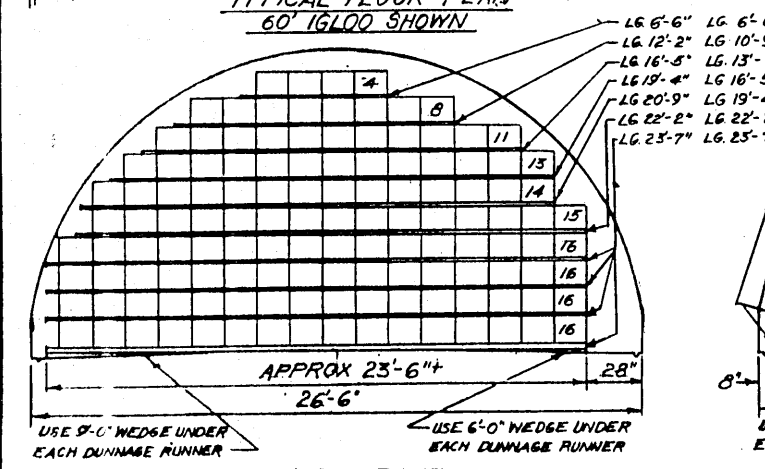
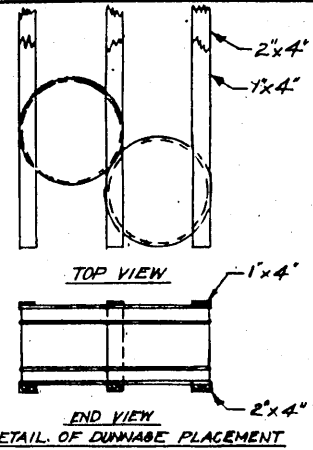
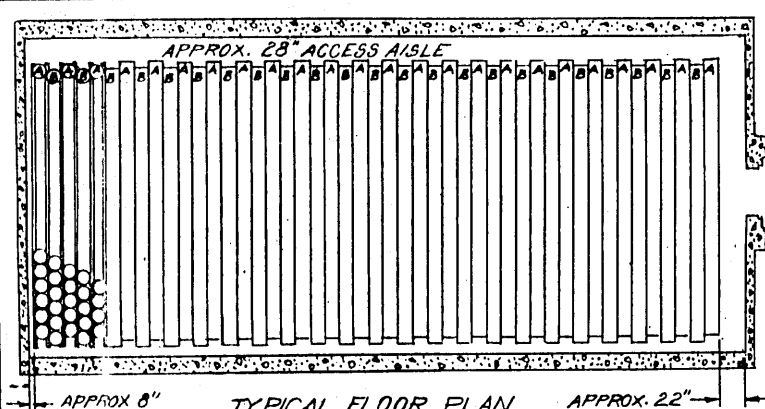

STACK "A" ELEVATION
125 BOMBS

BOMB FRAG (4 LB) ON WOOD DUNNAGE

STACK "B" ELEVATION
121 BOMBS

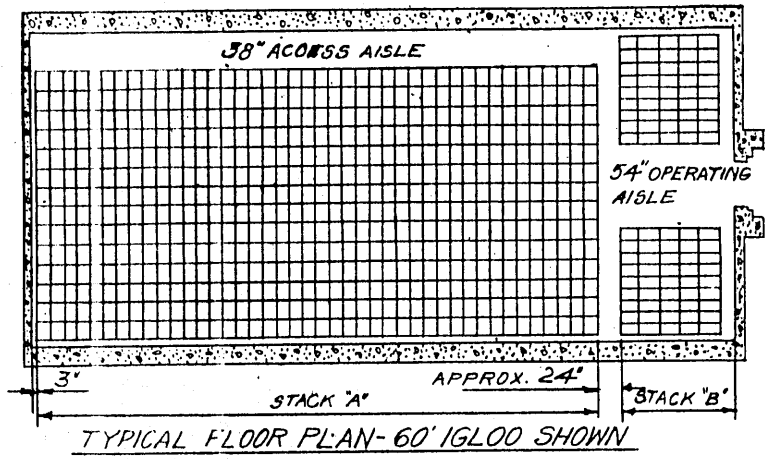

NOTE:
FOR PACKING & MARKING OF PALLET
SEE 76-18-2 & 76-18-3.

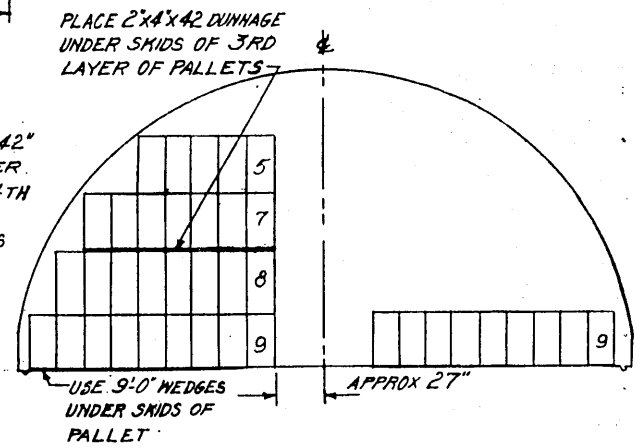
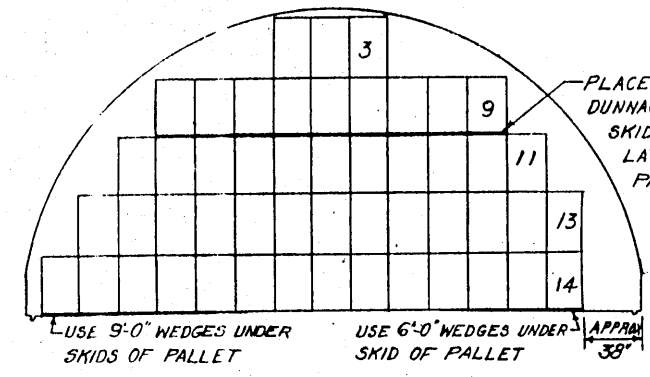

STACK "A" ELEVATION
(300 BOMBS)

STACK "B" ELEVATION
(228 BOMBS)

BOMB FRAG (90 LBS) PALLETIZED

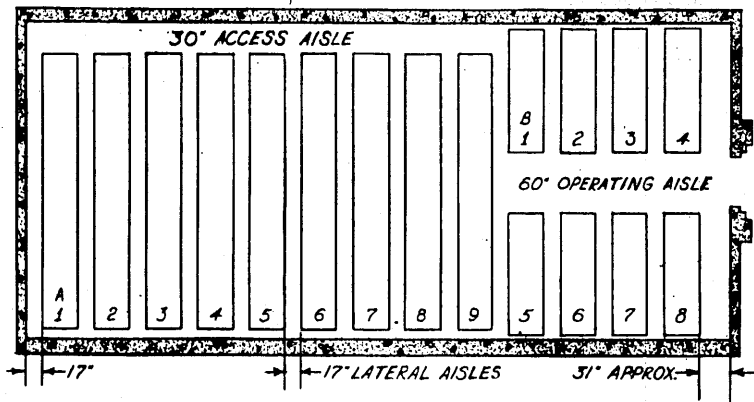

TYPICAL FLOOR PLAN 60' IGLOO SHOWN

NOTE*
4-12d NAILS ON EACH SIDE OF JOINT.

POSITION STRAP IN PROCESS OF STORING (FOR LOCATION SEE STACK ELEVATIONS)

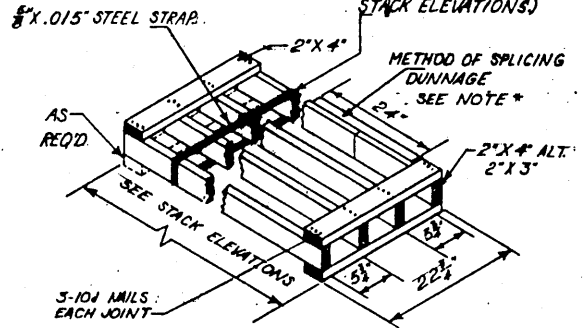

DUNNAGE DETAIL

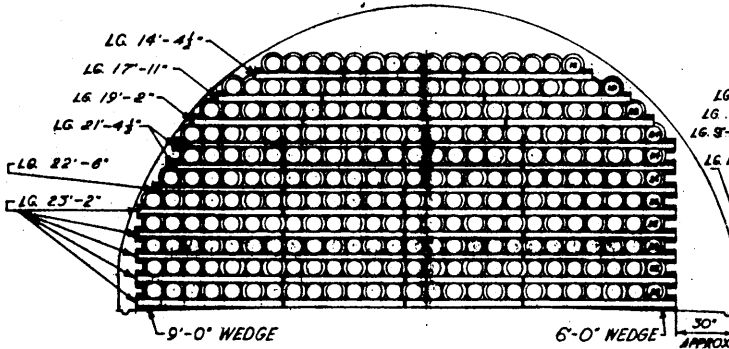

STACK 'A' ELEVATION

26 BOMBS

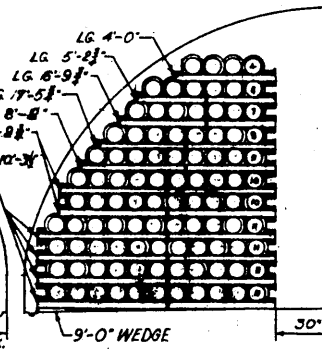

STACK 'B' ELEVATION

98 BOMBS

BOMB, FRAG. (220 LBS) WITH SHIPPING BANDS ON WOOD DUNNAGE

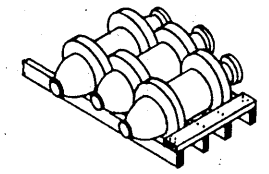

DETAIL - PLACEMENT OF BOMB ON DUNNAGE

USE 2" X 4" LUMBER OF RANDOM LENGTHS 4 INCHES APART, NAIL TO EACH CROSSWISE 2" X 4" WITH ONE NAIL. JOINTS IN LENGTHWISE MEMBER SHOULD OCCUR OVER CENTER OF STACK. SPACING OF CROSSWISE MEMBERS SHOULD BE THE SAME AS FOR BOMB ASSEMBLIES.

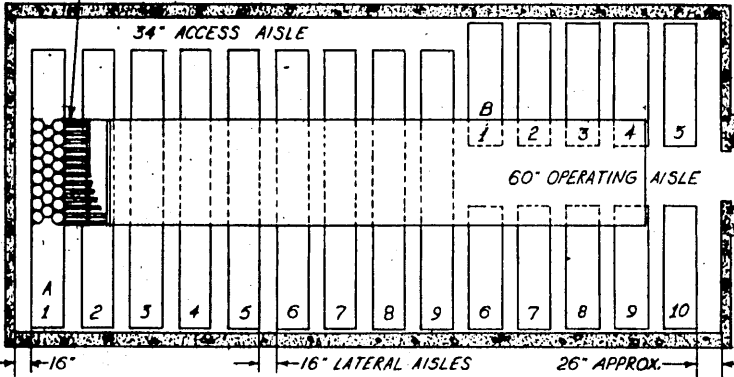

TYPICAL FLOOR PLAN 60' IGLOO SHOWN

NAIL END STOPS TO DUNNAGE WITH 3 12d NAILS

DETAIL OF INTERMEDIATE DUNNAGE ASSEMBLY

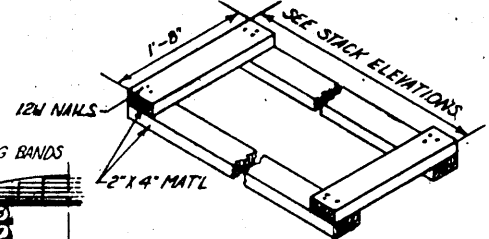
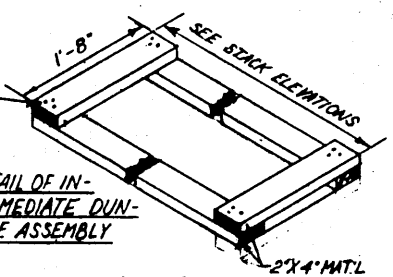

DETAIL OF FLOOR DUNNAGE ASSEMBLY

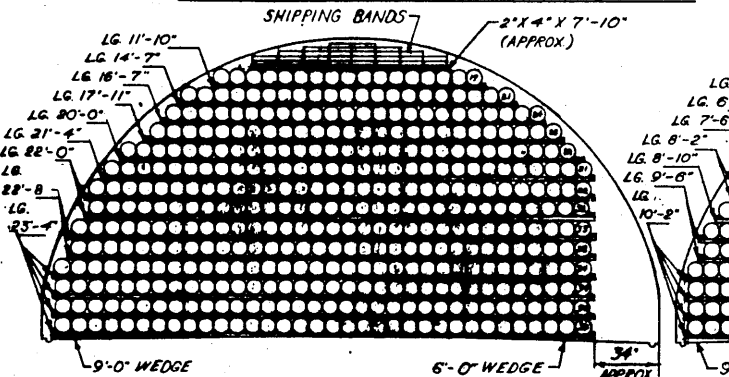

STACK 'A' ELEVATION

414 BOMBS

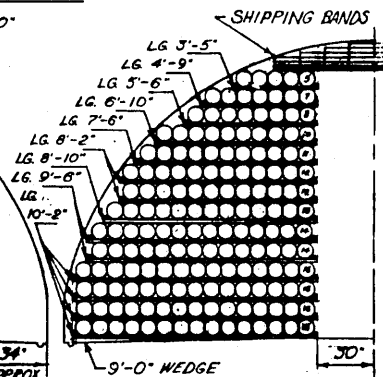

STACK 'B' ELEVATION

166 BOMBS

BOMB, FRAG. (220 LBS) AND SHIPPING BANDS ON WOOD DUNNAGE

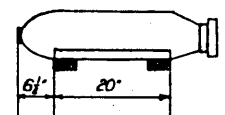

PLACEMENT OF BOMB ON DUNNAGE

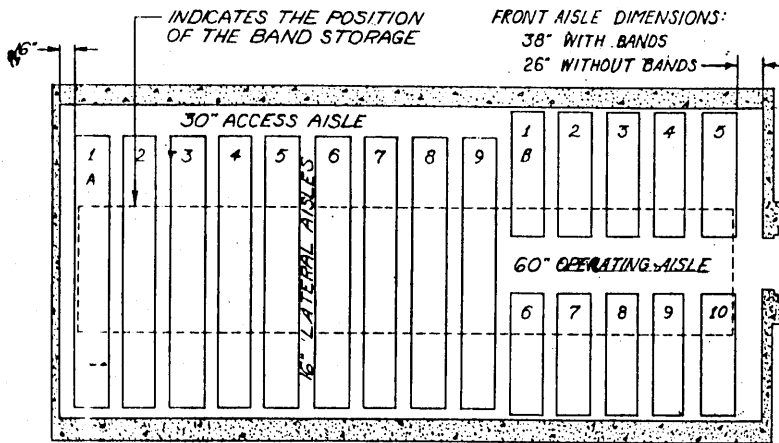

TYPICAL FLOOR PLAN

60' IGLOO - W/O BANDS

WHEN BOMB IS STORED WITH BANDS IN PLACE OMIT 2" B" STACKS FROM FLOOR PLAN. NOTE FRONT AISLE DIMENSIONS.

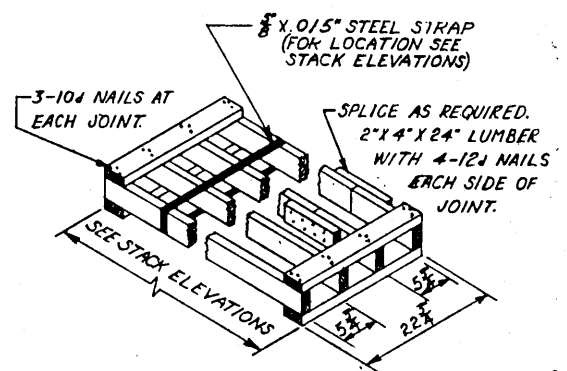

DUNNAGE DETAIL

MAT'L - 2" X 4" (ALT 2" X 3")

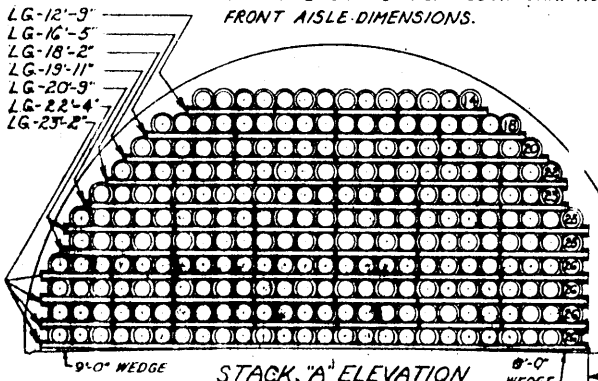

STACK 'A' ELEVATION

251 BOMBS

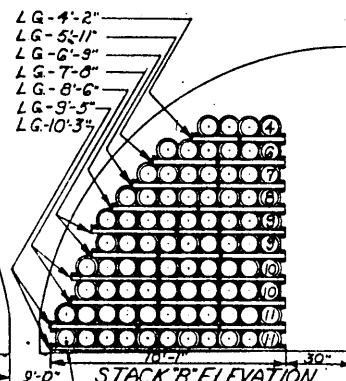

STACK 'B' ELEVATION

85 BOMBS

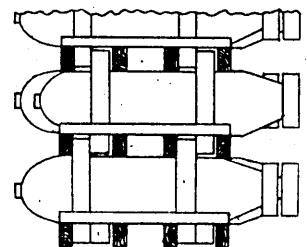

PARTIAL END ELEVATION

BOMB FRAG (260LBS) WITH SHIPPING BANDS ON WOOD DUNNAGE

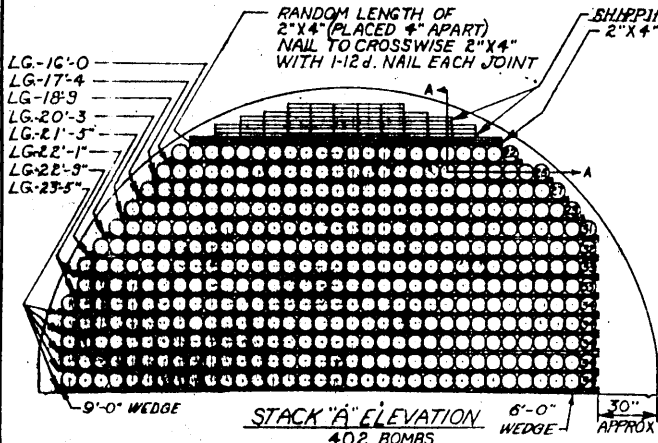

STACK 'A' ELEVATION

402 BOMBS

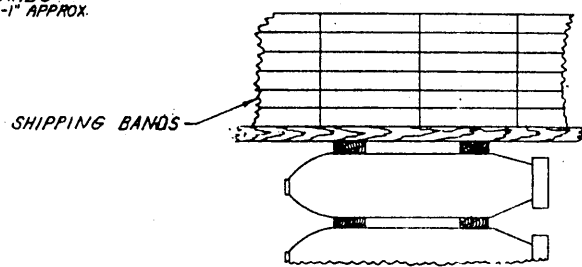

SECTION 'A-A'

260LB. FRAG. W/O BANDS

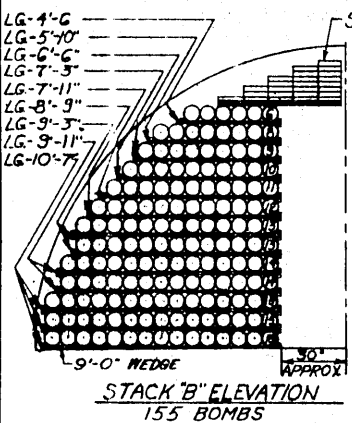

STACK 'B' ELEVATION

155 BOMBS

FLOOR PLAN IDENTICAL TO THAT SHOWN ABOVE.

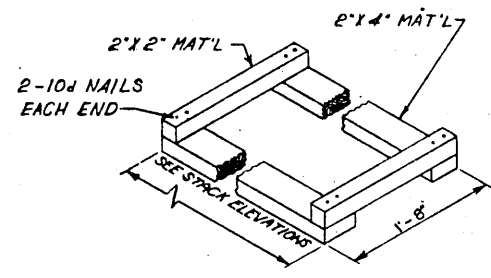

DUNNAGE DETAIL

BOMB FRAG (260LBS) AND SHIPPING BANDS ON WOOD DUNNAGE

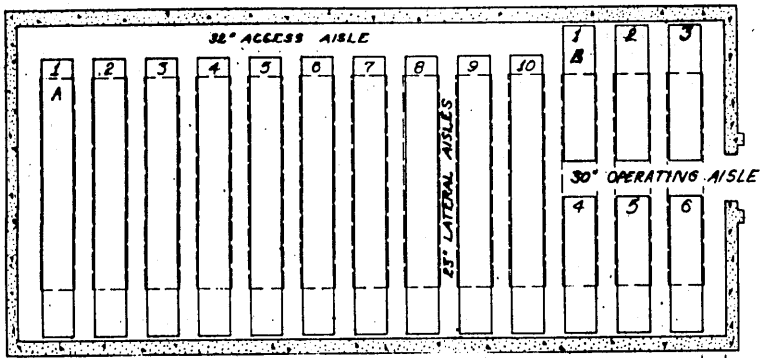

TYPICAL FLOOR PLAN

- L.G. 18'-0"
- L.G. 19'-1"
- L.G. 20'-6"
- L.G. 21'-1"
- L.G. 21'-9"
- L.G. 22'-5"
- L.G. 23'-1"

- L.G. 18'-0"
- L.G. 8'-4"
- L.G. 9'-0"
- L.G. 10'-8"
- L.G. 11'-1"
- L.G. 11'-8"

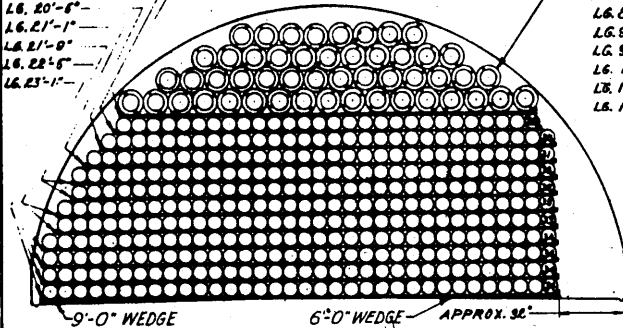

STACK "A" ELEVATION
SEE BOMBS

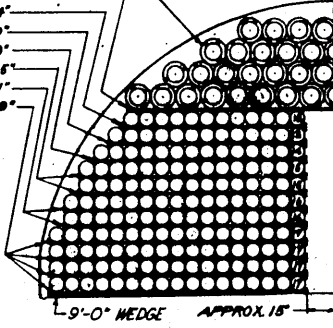

STACK "B" ELEVATION
168 BOMBS

BOMB, G.P. (100 LBS.) AND SHIPPING BANDS ON WOOD DUNNAGE

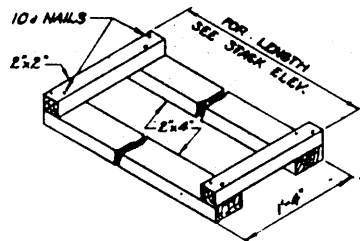

FLOOR DUNNAGE & DUNNAGE FOR SHIPPING BANDS

NAIL 1 1/4" TO UNDERSIDE OF 2x2" WITH TWO 6x NAILS.

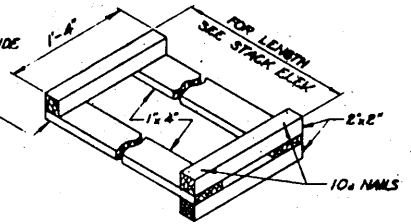

INTERMEDIATE DUNNAGE

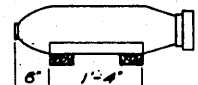

POSITION OF BOMB ON DUNNAGE

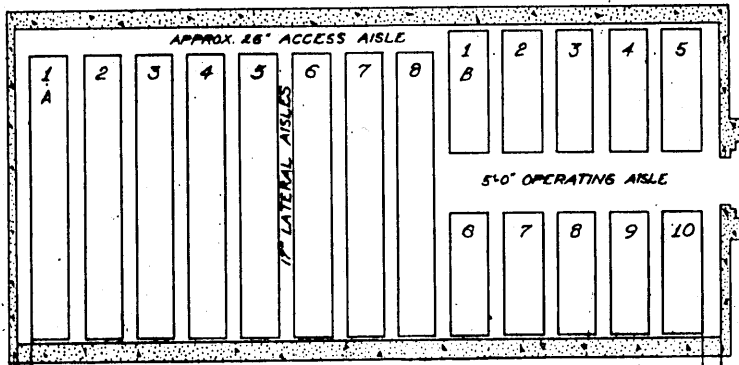

TYPICAL FLOOR PLAN

- L.G. 18'-8"
- L.G. 19'-3"
- L.G. 20'-4"
- L.G. 21'-1"
- L.G. 22'-7"
- L.G. 23'-8"

- L.G. 4'-2"
- L.G. 5'-4"
- L.G. 6'-6"
- L.G. 7'-7"
- L.G. 8'-10"
- L.G. 9'-11"

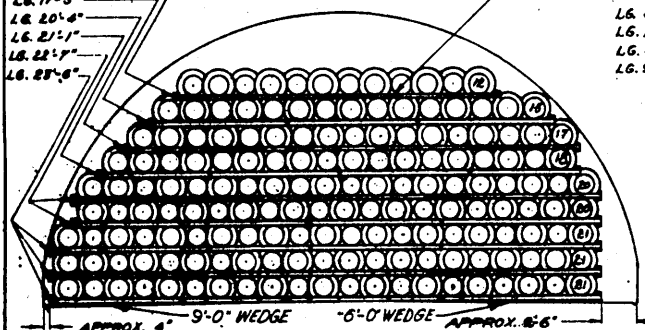

STACK "A" ELEVATION
166 BOMBS

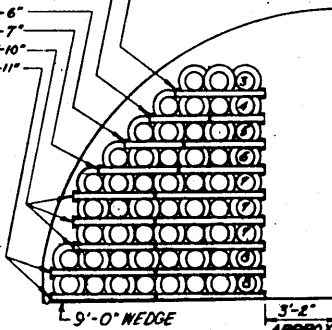

STACK "B" ELEVATION
55 BOMBS

BOMB, G.P. (250 LBS.) WITH SHIPPING BANDS, ON WOOD DUNNAGE

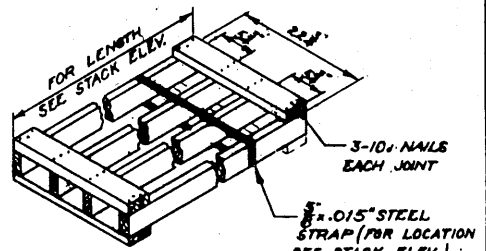

DUNNAGE DETAIL
MATERIAL 2x4" (ALT. 2x3")

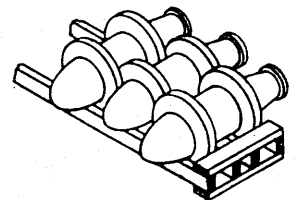

PLACEMENT OF BOMBS ON DUNNAGE

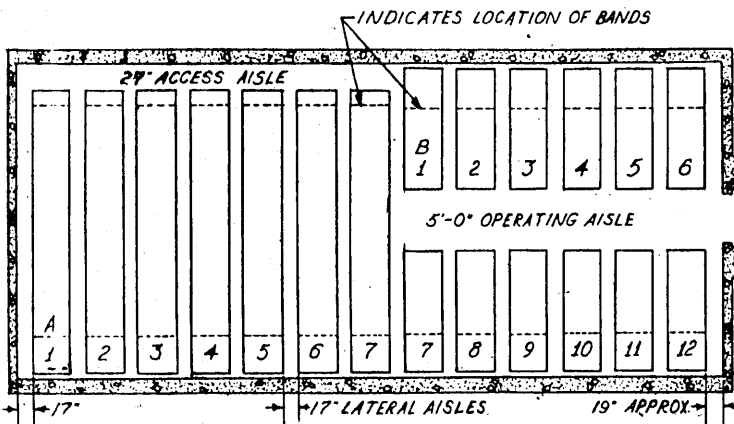

TYPICAL FLOOR PLAN 60' IGLOO SHOWN

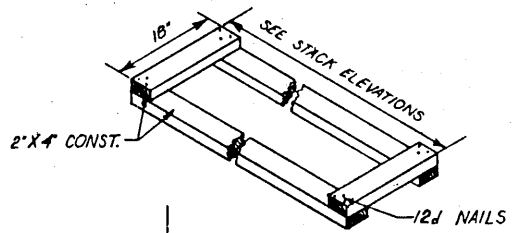
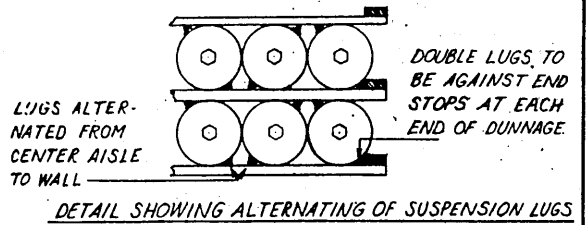

DETAIL OF DUNNAGE

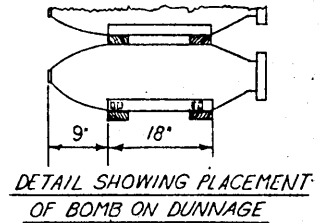
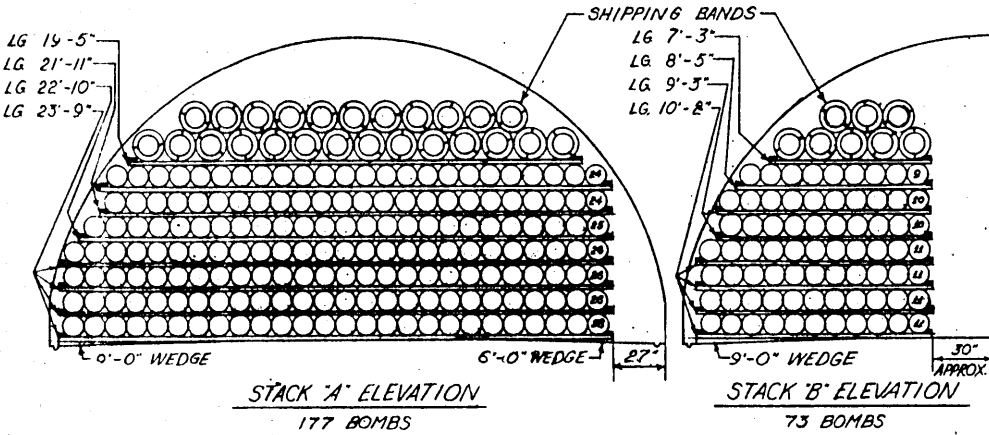

BOMB, G.P. (250 LBS.) WITHOUT SHIPPING BANDS ON WOOD DUNNAGE

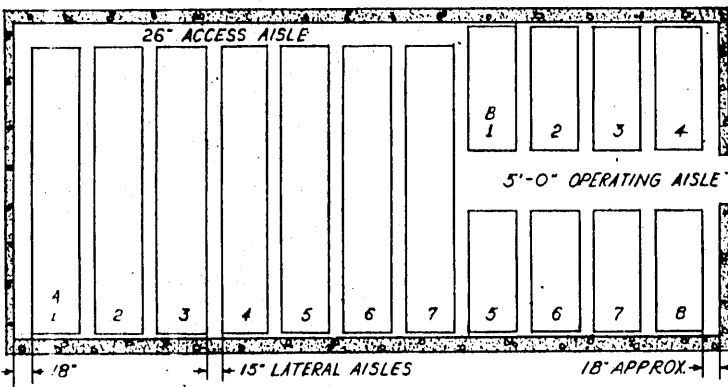

TYPICAL FLOOR PLAN 60' IGLOO SHOWN

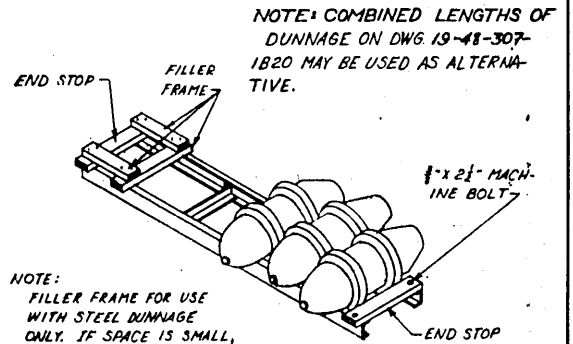

NOTE: FOR WOOD DUNNAGE THE END STOP MAY BE NAILED IN DESIRED LOCATION. SPLICE AS REQUIRED. 4-12d NAILS EACH SIDE OF BREAK

DETAIL SHOWING PLACEMENT OF BOMB ON DUNNAGE

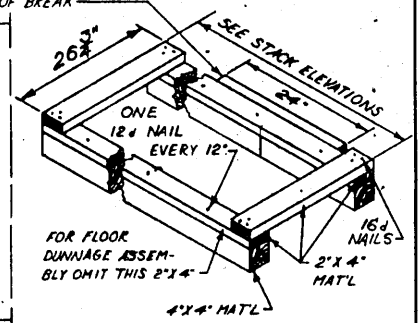
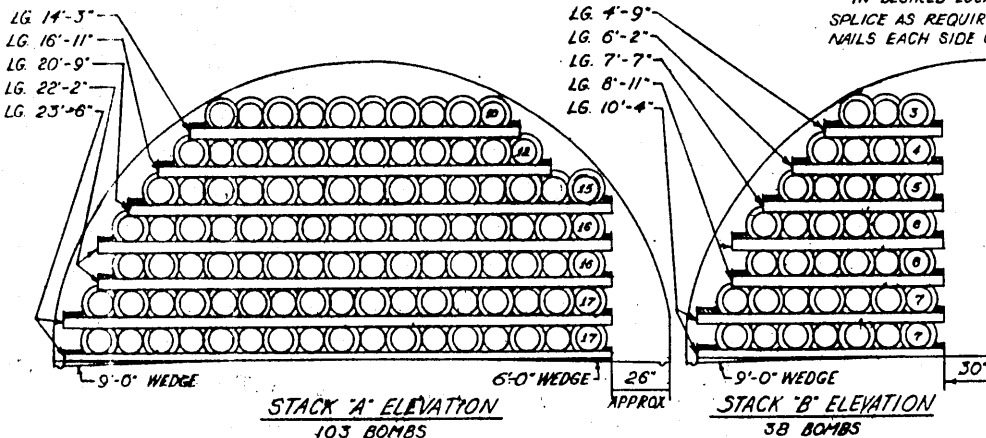

DETAIL OF DUNNAGE

BOMB, DEMO. & G.P. (500 LBS) WITH SHIPPING BANDS ON STEEL OR WOOD DUNNAGE

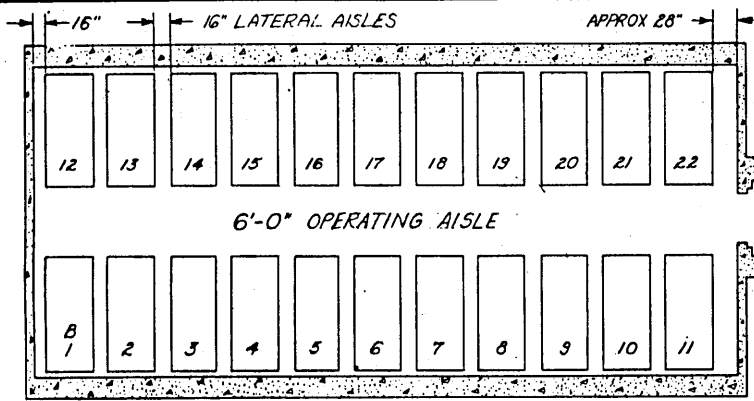

TYPICAL FLOOR PLAN
60' IGLOO

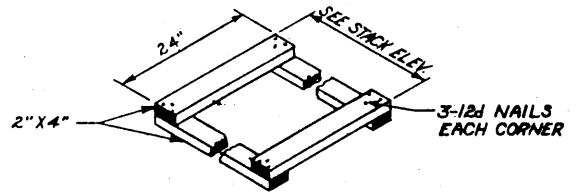

DETAIL OF DUNNAGE ASSEMBLY

10 BUNDLES OF SHIPPING BANDS
8 BUNDLES OF 17 BANDS EACH &
2 BUNDLES OF 18 BANDS EACH
TOTAL - 172 BANDS
(86 ON EACH STACK)

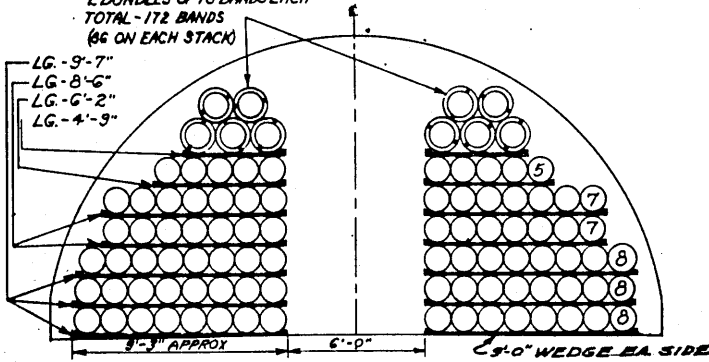

CROSS SECTION
3 BOMBS PER STACK

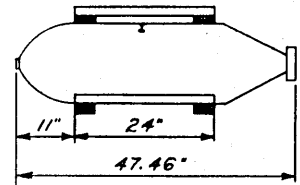

DETAIL SHOWING PLACEMENT
OF BOMB ON DUNNAGE

BOMB DEMO & GP. 500LB & SHIPPING BANDS. 250,000 LB. EXPLOSIVE LIMIT

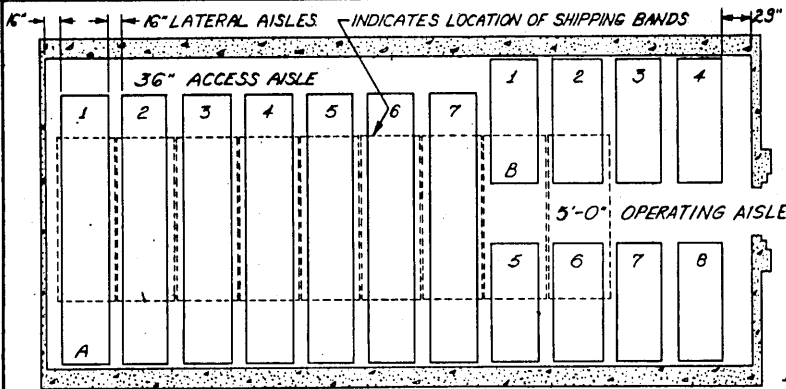

TYPICAL FLOOR PLAN
60' IGLOO

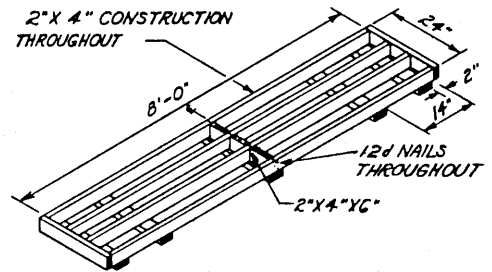

DETAIL OF BRIDGE

NOTE: DUNNAGE CONSTRUCTION IS THE SAME AS SHOWN ABOVE. USE LENGTHS AS DESIGNATED ON STACK ELEVATIONS. PLACEMENT OF BOMB ON DUNNAGE, SAME AS ABOVE.

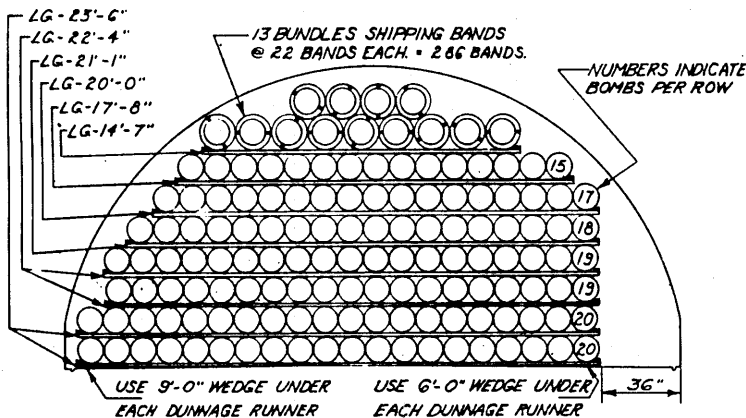

STACK ELEVATION "A" - 128 BOMBS

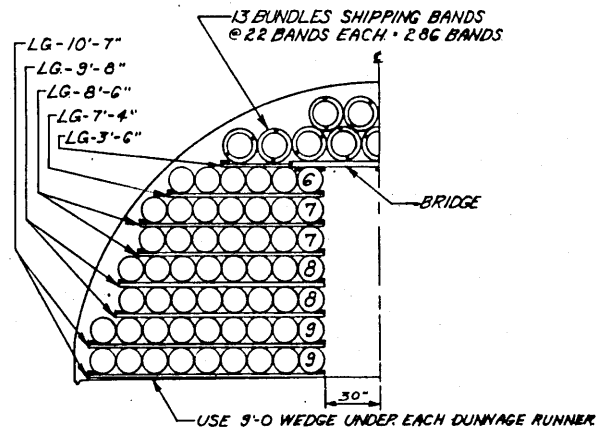

STACK ELEVATION "B" - 54 BOMBS

BOMB DEMO & GP. 500LB & SHIPPING BANDS. 500,000 LB. EXPLOSIVE LIMIT

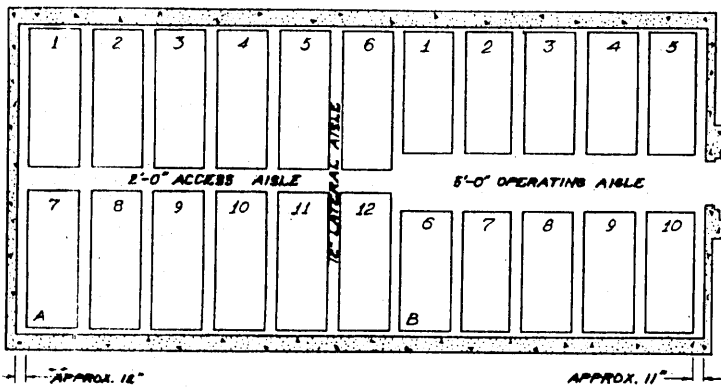

TYPICAL FLOOR PLAN
80' 18L00

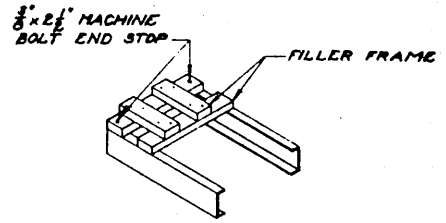

DETAIL OF FILLER FRAME

NOTE: FOR USE WITH STEEL DUNNAGE, IF SPACE IS SMALL, RANDOM LENGTHS OF LUMBER MAY BE USED. FOR WOOD DUNNAGE END STOPS MAY BE NAILED IN DESIRED LOCATION.

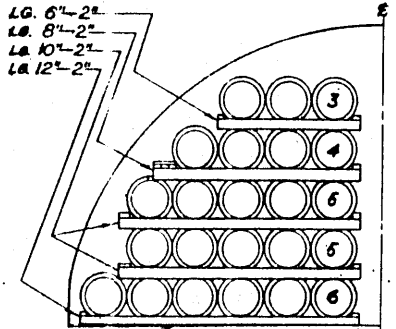

STACK A ELEVATION
23 BOMBS

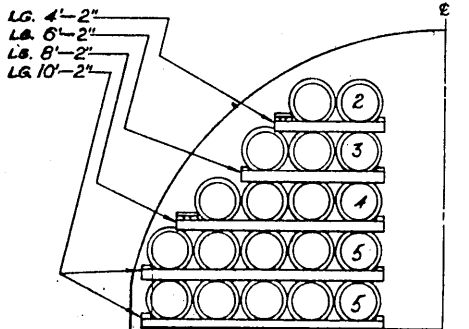

STACK B ELEVATION
18 BOMBS

NOTE: WOOD DUNNAGE (SEE DETAIL BELOW) OR STEEL DUNNAGE DWS 19-48-307-1B20 MAY BE USED IN STORAGE.

BOMB, DEMO & GP (1000 LBS) WITH SHIPPING BANDS ON STEEL OR WOOD DUNNAGE, 250,000 LBS EXPL. LIMIT.

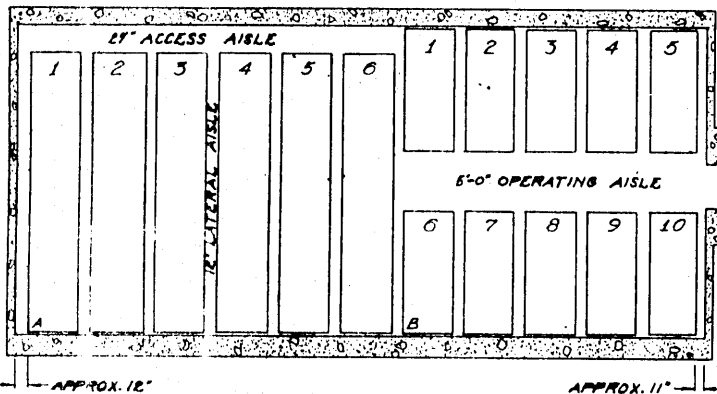

TYPICAL FLOOR PLAN
80' 18L00

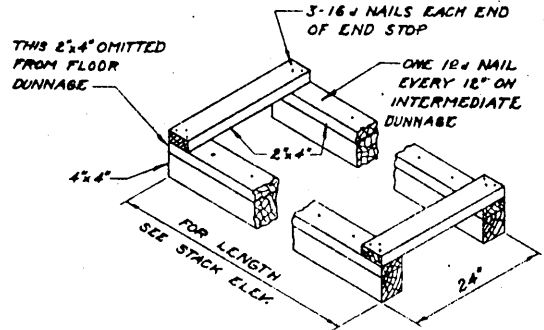

DUNNAGE DETAIL

NOTE: COMBINED LENGTHS OF STEEL DUNNAGE SHOWN ON DWS 19-48-307-1B20 MAY BE USED AS ALTERNATIVE

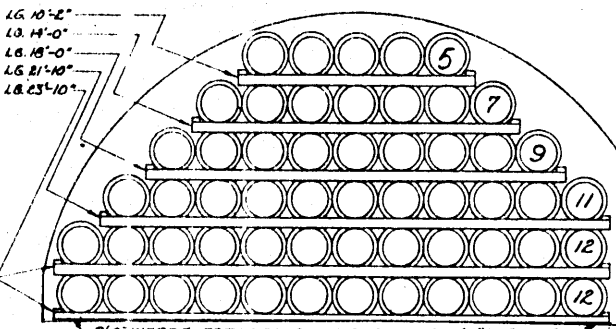

STACK A ELEVATION
56 BOMBS

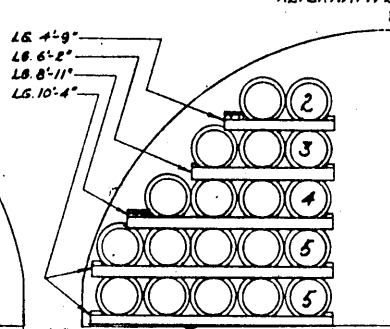

STACK B ELEVATION
18 BOMBS

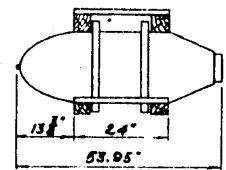

DETAIL SHOWING POSITION OF BOMB ON DUNNAGE

BOMB, DEMO & GP (1000 LBS) WITH SHIPPING BANDS ON STEEL OR WOOD DUNNAGE, 500,000 LBS EXPL. LIMIT

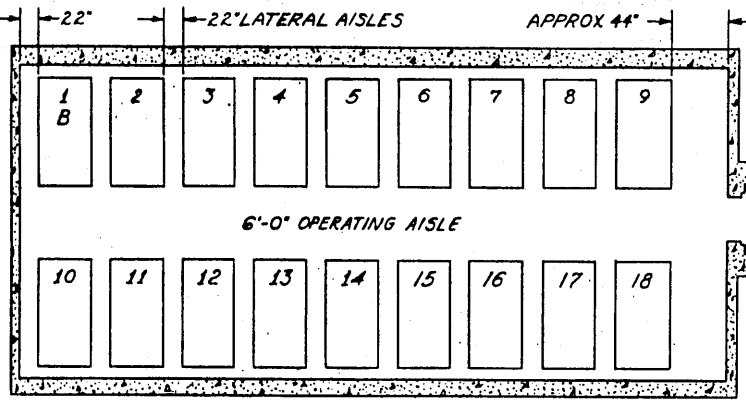

TYPICAL FLOOR PLAN
60' x 60'

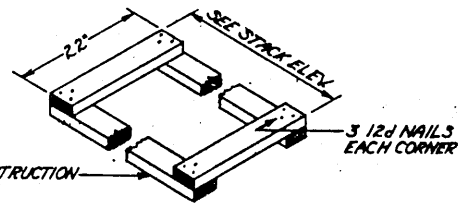

DETAIL DUNNAGE ASSEMBLY

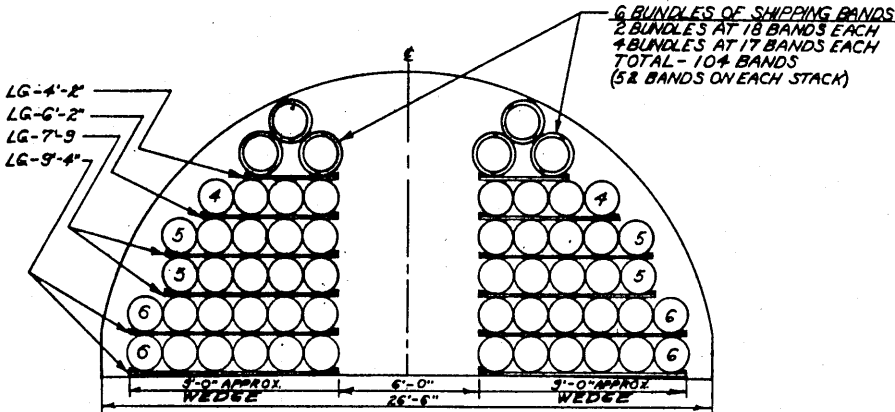

CROSS SECTION
26 BOMBS PER STACK

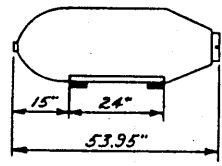

DETAIL SHOWING PLACEMENT OF BOMB ON DUNNAGE

BOMB, DEMO & GP. (1000LBS) & SHIPPING BANDS ON WOOD DUNNAGE 250,000LBS EXPL. LIMIT

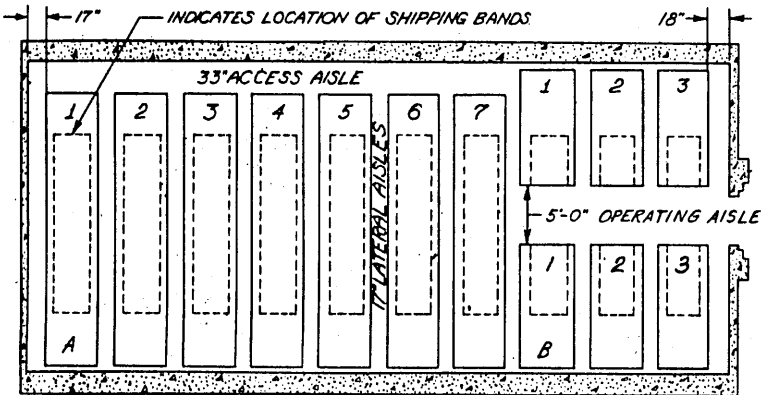

TYPICAL FLOOR PLAN
60' x 60'

NOTE:

DUNNAGE CONSTRUCTION IS THE SAME AS SHOWN ABOVE. USE LENGTHS AS DESIGNATED ON STACK ELEVATION. PLACEMENT OF BOMB ON DUNNAGE, SAME AS ABOVE.

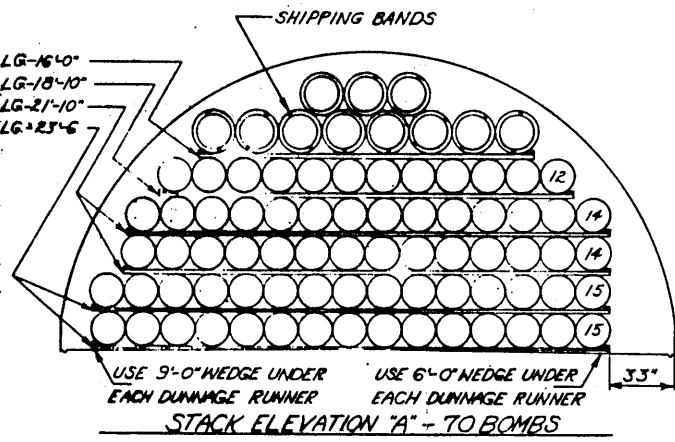

STACK ELEVATION "A" - TO BOMBS

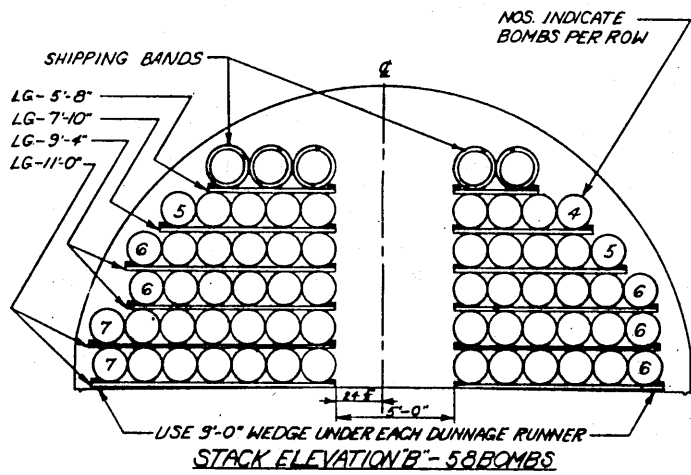

STACK ELEVATION "B" - 58 BOMBS

BOMB, DEMO & GP. (1000LBS) & SHIPPING BANDS ON WOOD DUNNAGE 500,000LBS EXPL. LIMIT

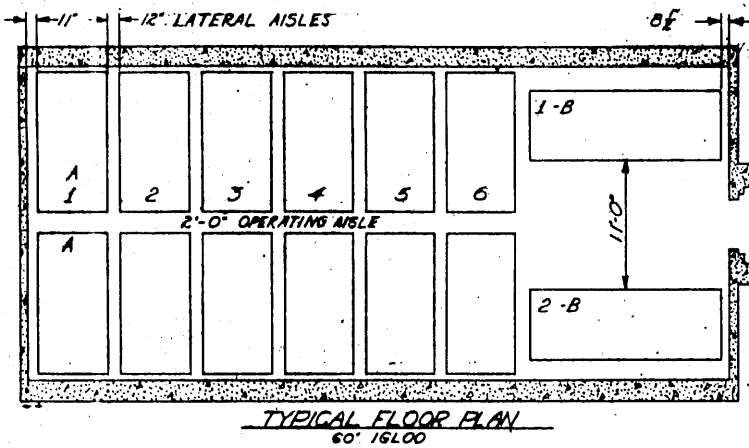

TYPICAL FLOOR PLAN
60' 16'00

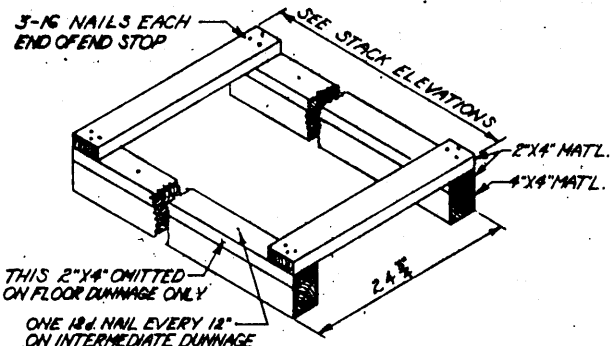

NOTE: DUNNAGE ASSEMBLY
STEEL DUNNAGE SHOWN ON ORD. DWG. 19-48-307-1820
MAY BE USED AS ALTERNATIVE

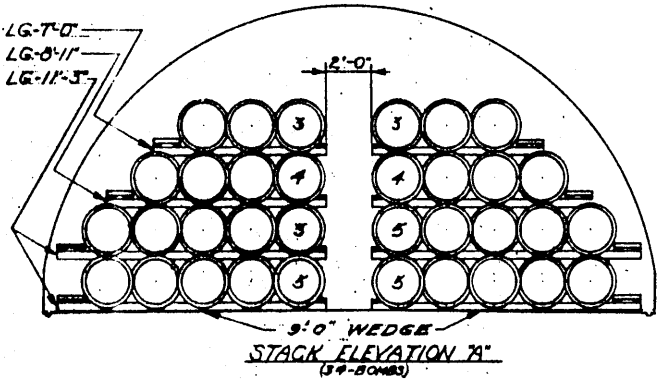

STACK ELEVATION "A"
(34 BOMBS)

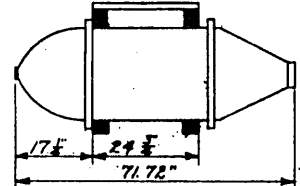

DETAIL SHOWING PLACEMENT
OF BOMB ON DUNNAGE

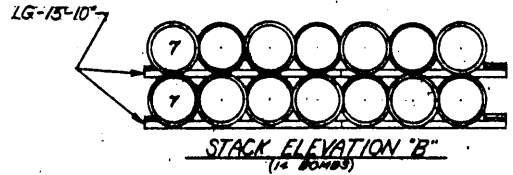

STACK ELEVATION "B"
(14 BOMBS)

BOMB DEMO. 6" GP. (2,000 LBS) WITH SHIPPING BANDS ON STEEL OR WOOD DUNNAGE 250,000 LBS. EXPL. LIMIT.

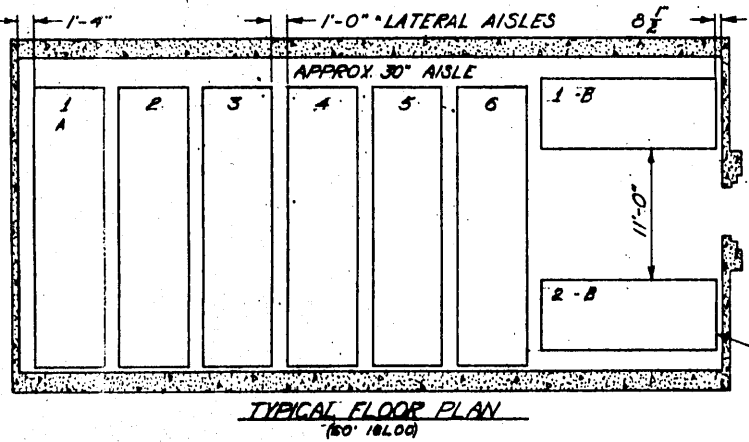

TYPICAL FLOOR PLAN
60' 18'00

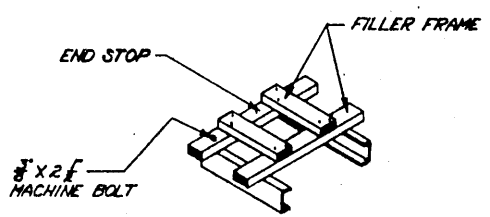

DETAIL OF FILLER FRAME

(FOR USE WITH STEEL DUNNAGE, IF SPACE IS SMALL
RANDOM PIECES OF LUMBER MAY BE USED)

NOTE:
SAME AS STACK ELEVATION "B" SHOWN ABOVE.

NOTE:
FOR WOOD DUNNAGE THE END STOPS MAY
BE NAILED IN DESIRED LOCATION.

DUNNAGE CONSTRUCTION IS THE SAME AS
SHOWN ABOVE. USE LENGTHS AS DESIGNATED
ON STACK ELEVATIONS. PLACEMENT OF
BOMB ON DUNNAGE SAME AS ABOVE.

NOTE:
COMBINED LENGTHS OF STEEL DUNNAGE
SHOWN ON ORD. DWG. 19-48-307-1820
MAY BE USED AS ALTERNATIVE.

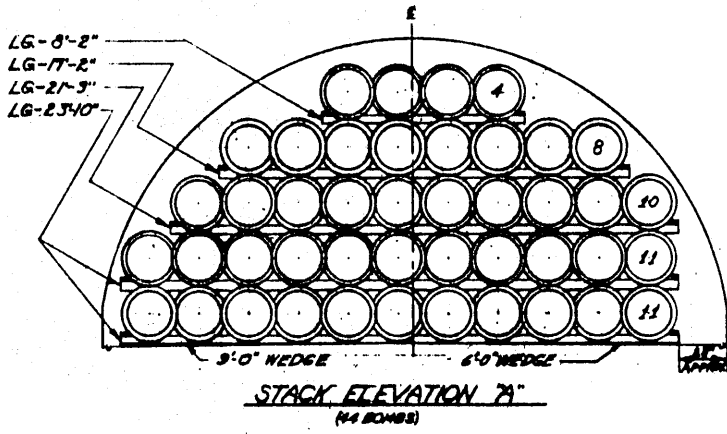

STACK ELEVATION "A"
(14 BOMBS)

BOMB DEMO. 6" GP. (2,000 LBS) WITH SHIPPING BANDS ON STEEL OR WOOD DUNNAGE 500,000 LBS. EXPL. LIMIT.

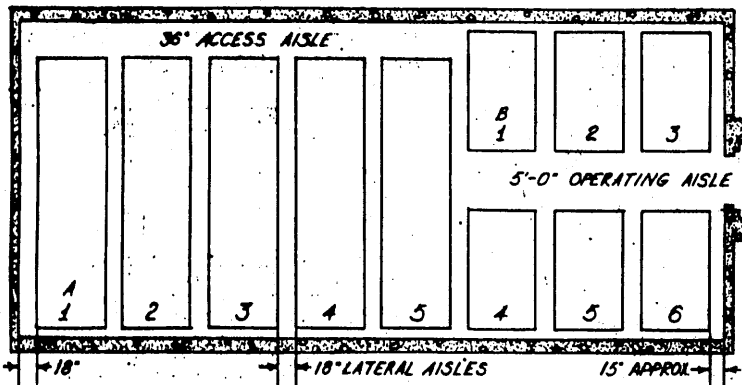

TYPICAL FLOOR PLAN 60' IGL00 SHOWN.

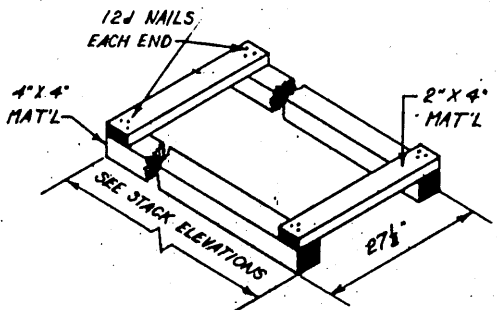

DUNNAGE DETAIL

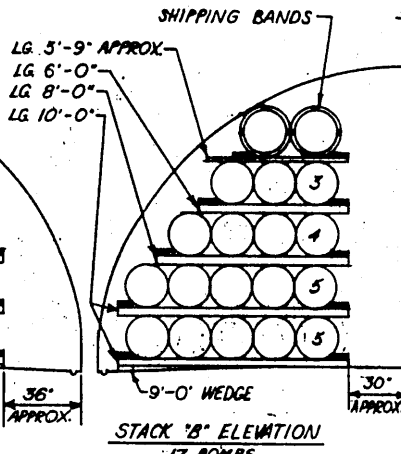
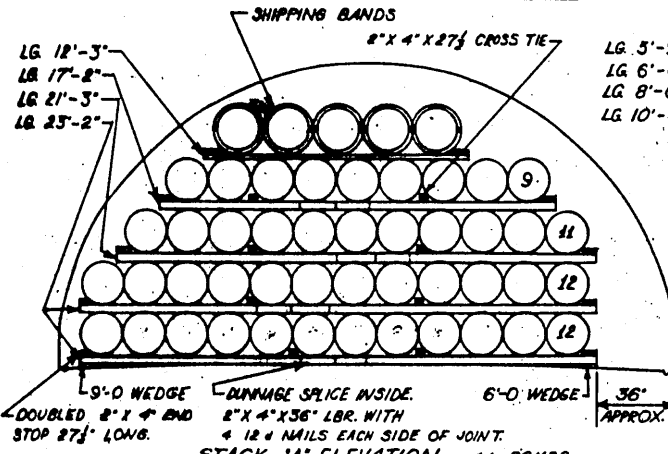

STACK 'B' ELEVATION 17 BOMBS

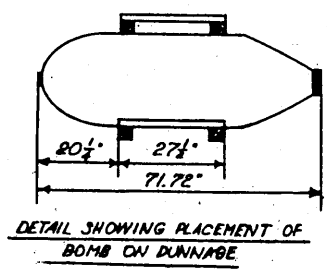

BOMB, DEMO & GP. (2000 LBS) AND SHIPPING BANDS ON WOOD DUNNAGE

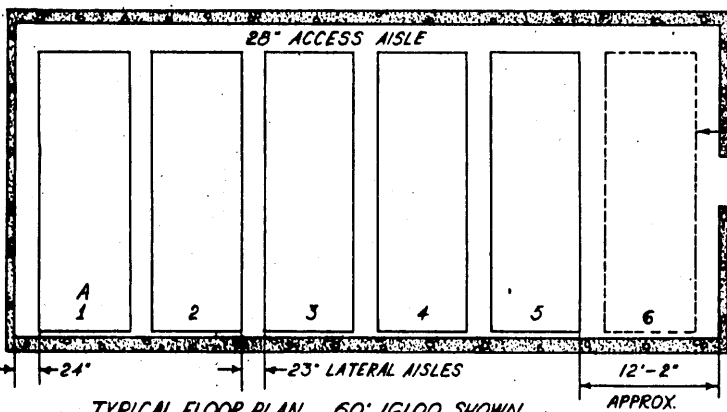

TYPICAL FLOOR PLAN 60' IGL00 SHOWN

SPECIAL NOTE:
 BOMBS SHOWN IN DOTTED LINES MAY BE ADDED TO STACKS IN MAGAZINES OF 500,000 LB EXPLOSIVE LIMIT.
 STACK 6 MAY BE ADDED TO MEET EXPLOSIVE LIMIT.
 THIS METHOD IS ALTERNATE TO THAT METHOD SHOWN ON PAGE 20.

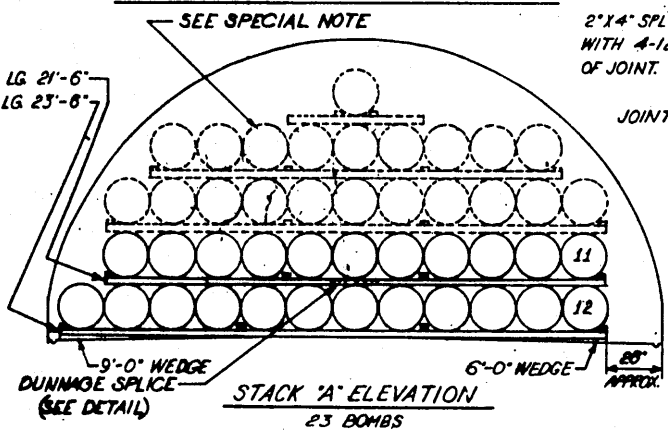
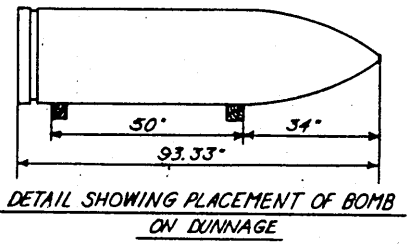

STACK 'A' ELEVATION 23 BOMBS

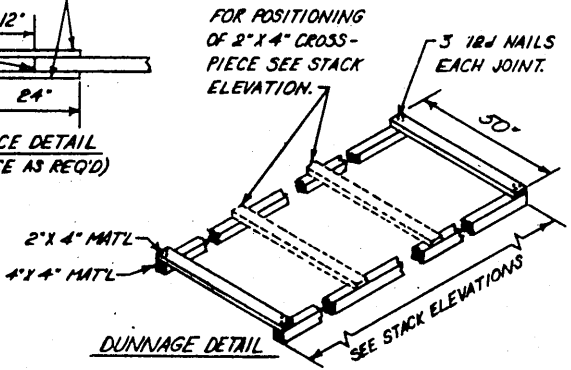

BOMB, DEMOLITION, 3000 LBS

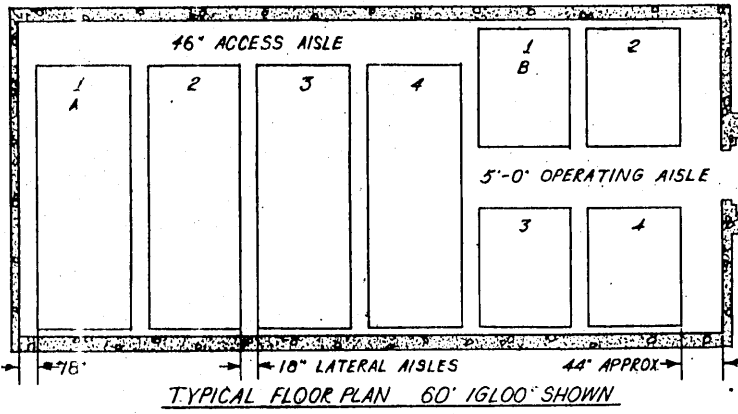

NOTE:
 NUMBER OF BOMBS PER MAGAZINE MAY BE INCREASED BY
 ADDING 3RD LAYER TO STACK. EXPLOSIVE LIMIT OF
 MAGAZINE NOT TO BE EXCEEDED.

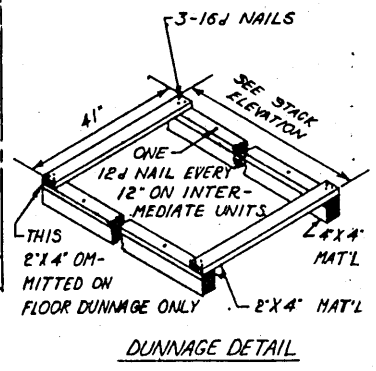
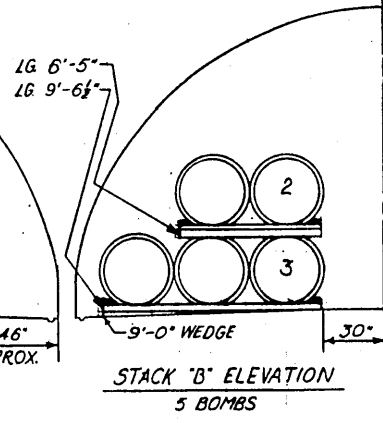
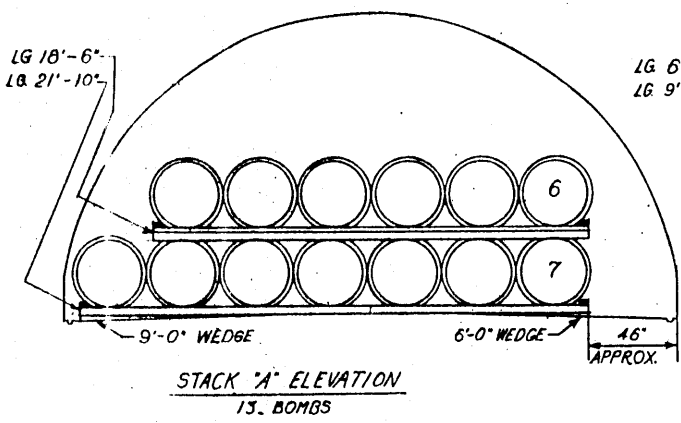
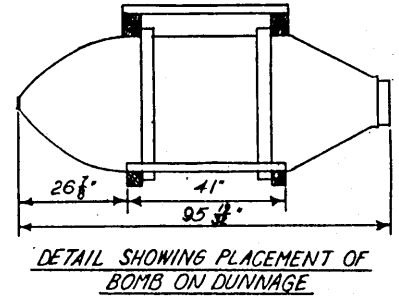

BOMB, L.G. (4000 LBS.) WITH SHIPPING BANDS ON WOOD DUNNAGE

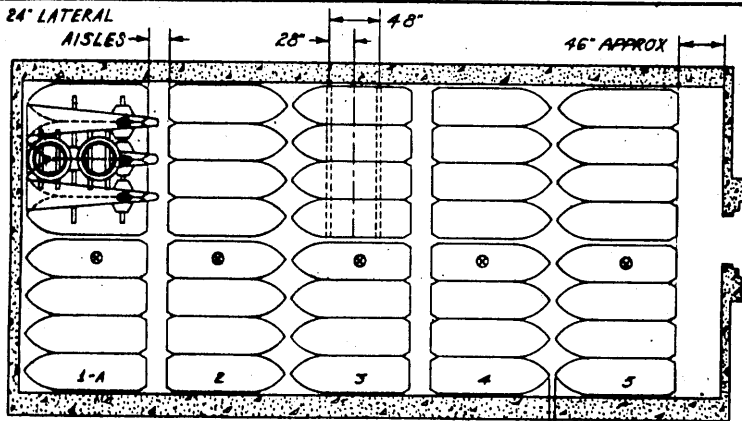

TYPICAL FLOOR PLAN
(60' ISL00)

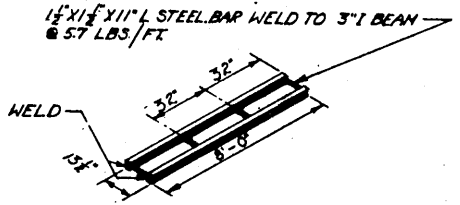

DETAIL - BOMB DOLLY
(AS REQ'D)

BILL OF MATERIAL - DOLLY
2-3" BEAMS @ 10 LBS./FT.
1-1 1/2 x 1 1/2 x 11' STEEL BARS

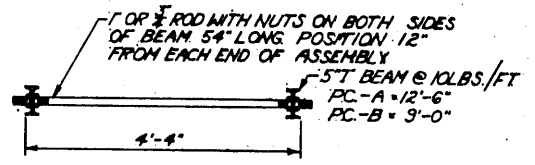

DETAIL - DUNNAGE ASSEMBLY
(FOR PLACEMENT OF BOMB ON DUNNAGE - SEE FLOOR PLAN)

NOTE:
BOMBS MARKED ⊗, WILL REMAIN ON CONVEYOR.

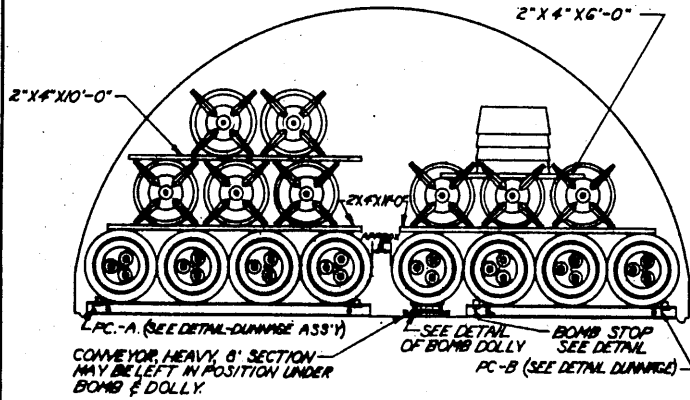

STACK 'A' ELEVATION
(8 BOMBS)

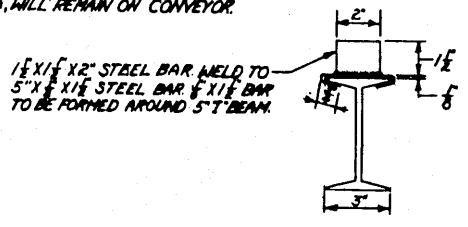

DETAIL - BOMB STOP
40 REQ'D - 60' ISL00

BOMB, G.P. 12,000 LBS. T10

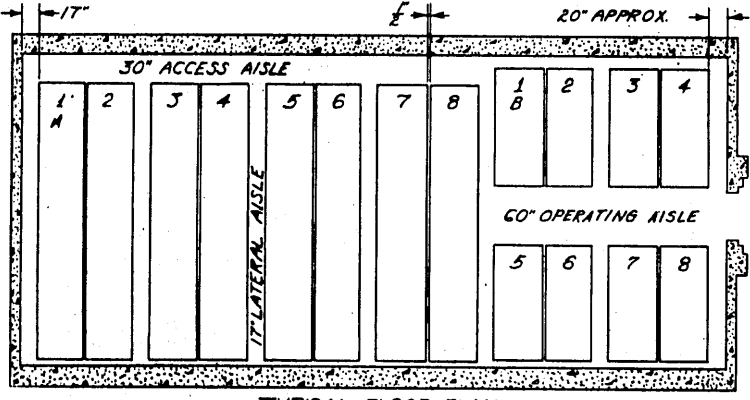

TYPICAL FLOOR PLAN
(60' ISL00)

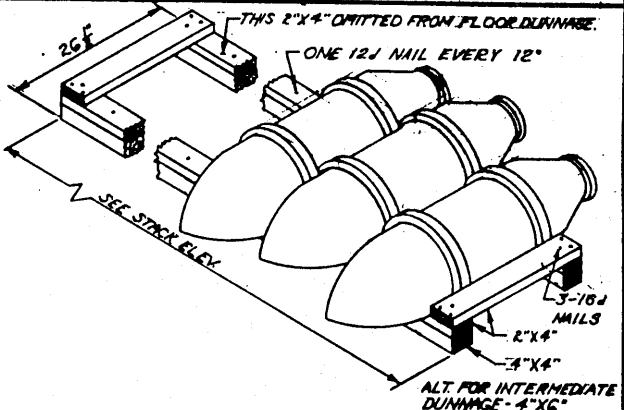

DUNNAGE DETAIL
PLACEMENT OF BOMB ON DUNNAGE

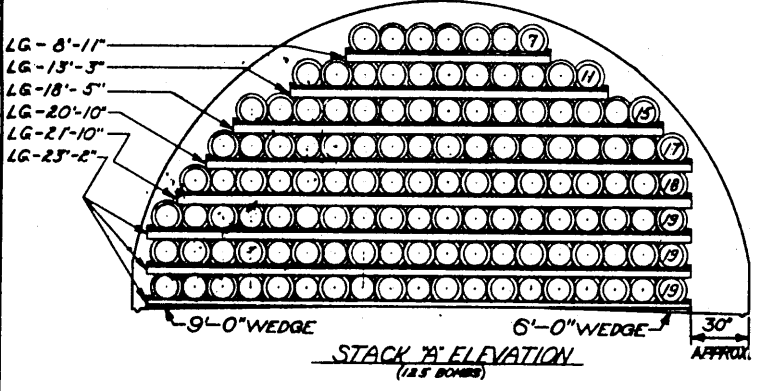

STACK 'A' ELEVATION
(18.5 BOMBS)

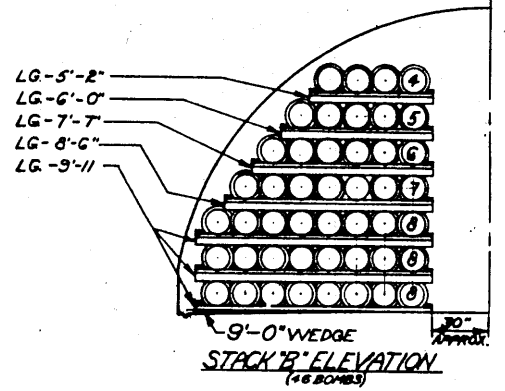

STACK 'B' ELEVATION
(16 BOMBS)

BOMB, S.A.P. (500LBS) WITH SHIPPING BANDS ON STEEL OR WOOD DUNNAGE 250,000 LBS. EXPL. LIMIT

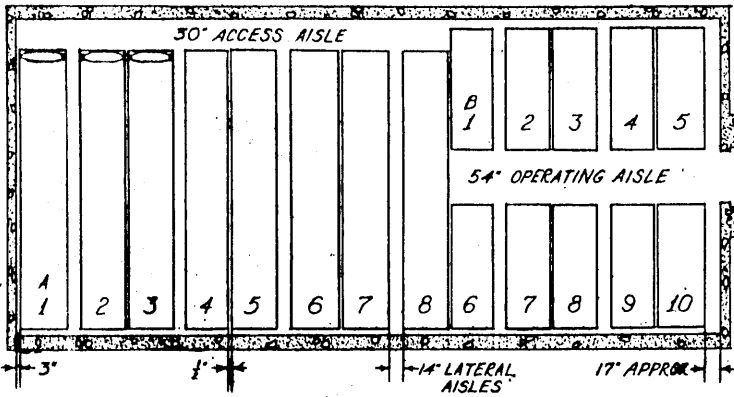

TYPICAL FLOOR PLAN 60' IGLOO SHOWN

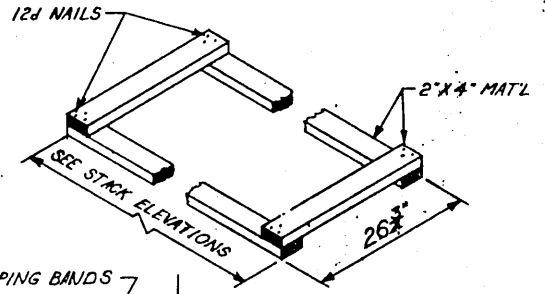

DUNNAGE DETAIL

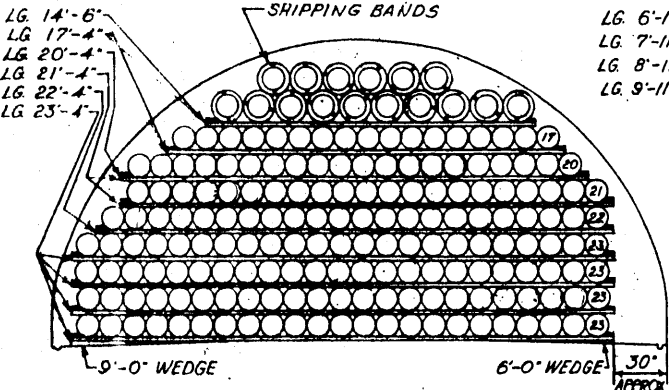

STACK 'A' ELEVATION
172 BOMBS

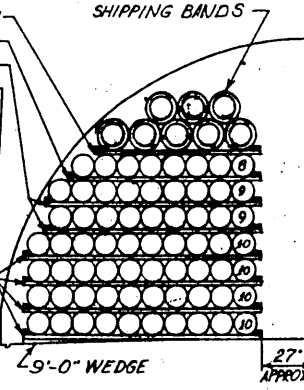

STACK 'B' ELEVATION
86 BOMBS

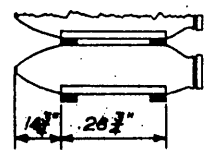

DETAIL SHOWING PLACE-
MENT OF BOMBS ON DUNNAGE

BOMB, S.A.P. (500 LBS.) AND SHIPPING BANDS ON WOOD DUNNAGE

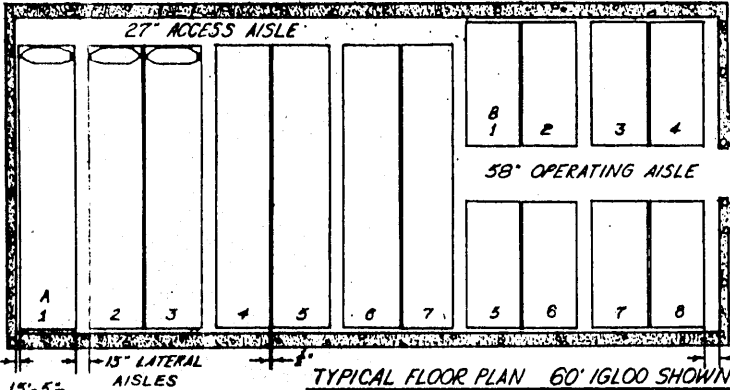

TYPICAL FLOOR PLAN 60' IGLOO SHOWN

NOTE:
COMBINED LENGTHS OF STEEL DUNNAGE SHOWN
ON ORD. DNG. 19-48-307-1820 TO BE USED
AS ALTERNATIVE FOR ERECTION OF STACK 'A'.

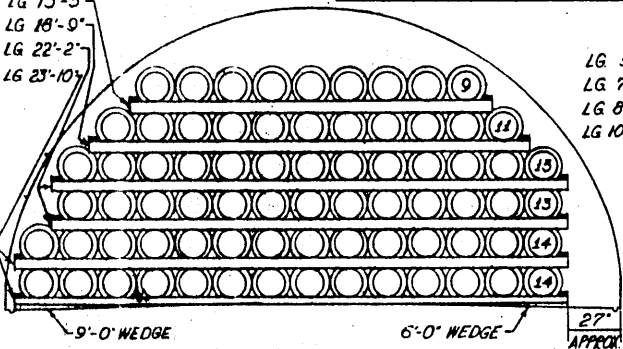

STACK 'A' ELEVATION
74 BOMBS

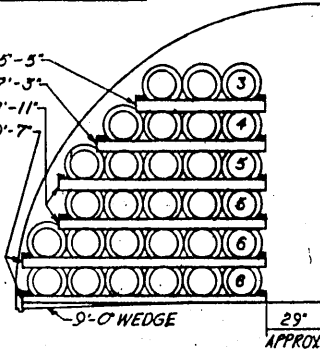

STACK 'B' ELEVATION
29 BOMBS

THIS 2"x4" OMITTED
ON FLOOR DUNNAGE
ONLY

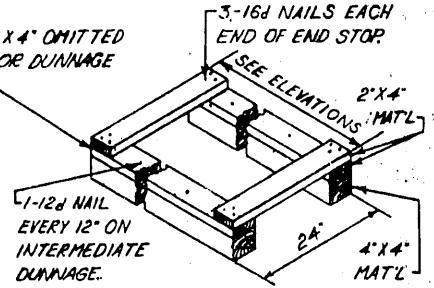

DUNNAGE DETAIL

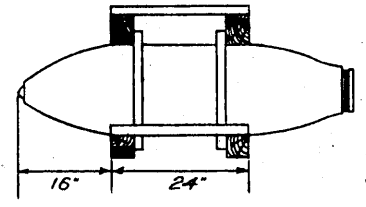

BOMB, S.A.P. (1000 LBS.) WITH SHIPPING BANDS ON STEEL OR WOOD DUNNAGE

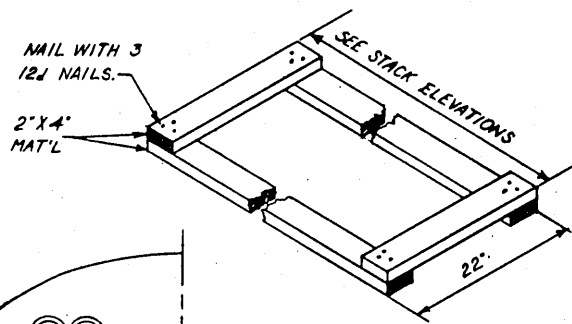
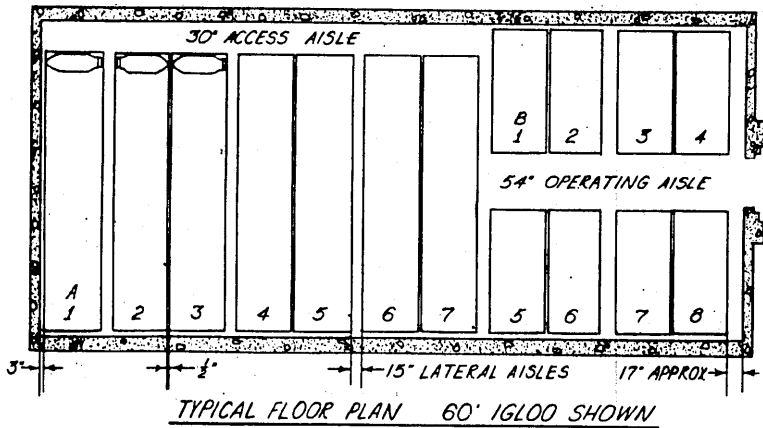

DUNNAGE DETAIL

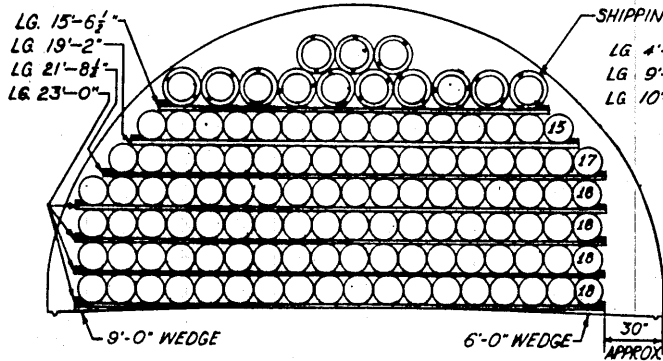

STACK 'A' ELEVATION

104 BOMBS

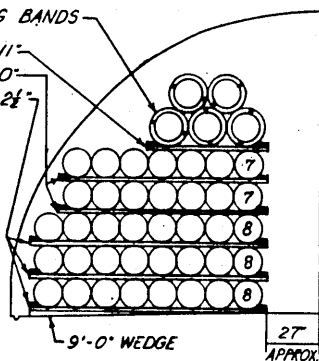

STACK 'B' ELEVATION

38 BOMBS

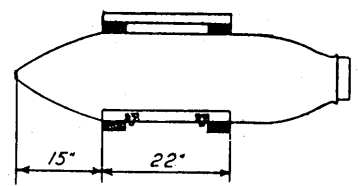

DETAIL SHOWING PLACEMENT OF BOMB ON DUNNAGE

BOMB, S.A.P. (1000 LBS.) AND SHIPPING BANDS ON WOOD DUNNAGE

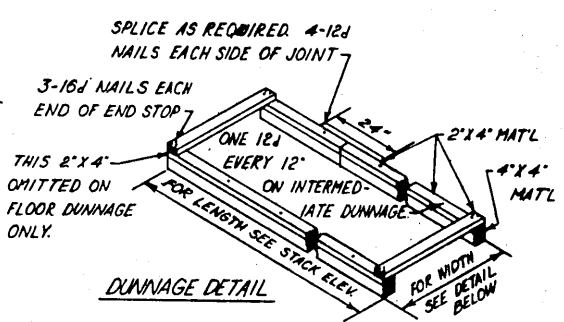
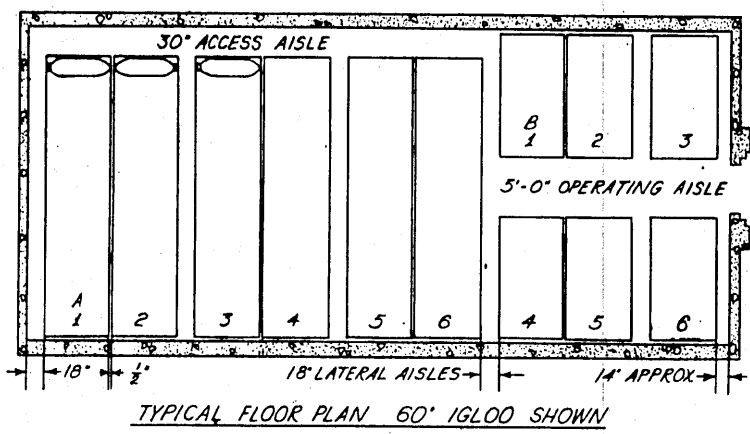

DUNNAGE DETAIL

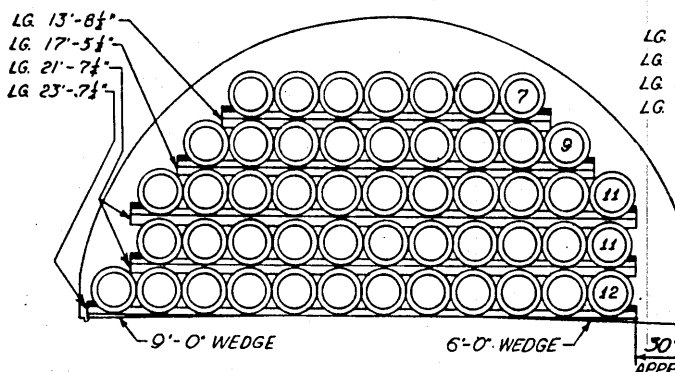

STACK 'A' ELEVATION

30 BOMBS

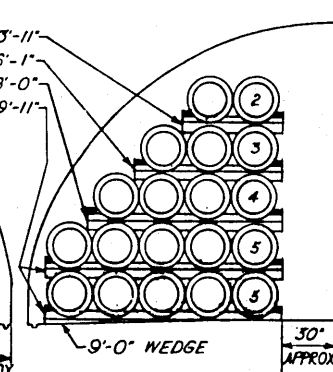

STACK 'B' ELEVATION

19 BOMBS

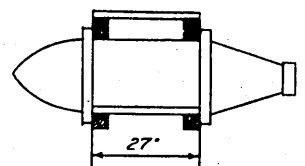
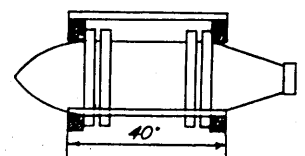

DETAIL SHOWING PLACEMENT OF BOMB ON DUNNAGE

BOMB, S.A.P. (2000 LBS.) WITH SHIPPING BANDS ON WOOD DUNNAGE

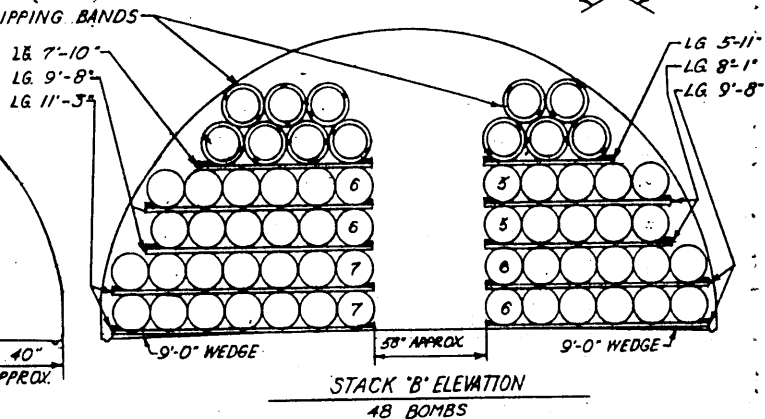
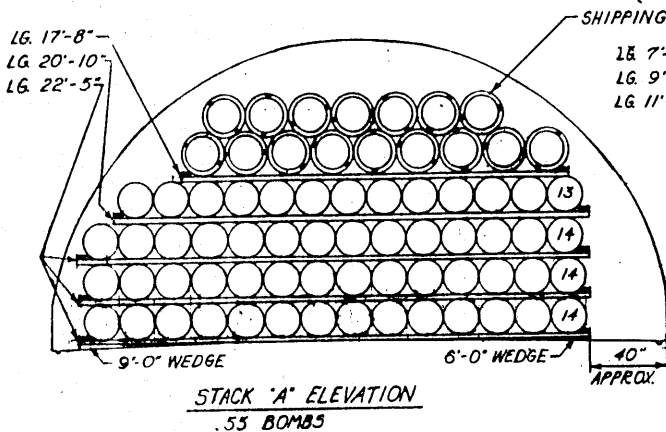
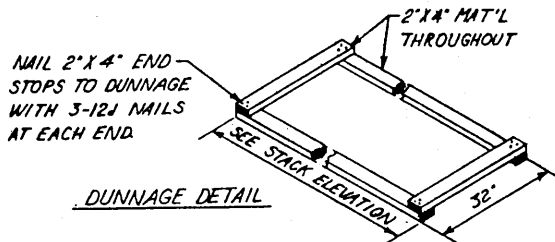
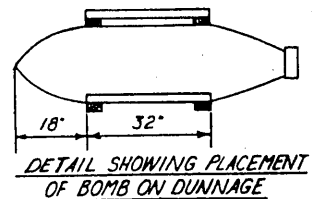
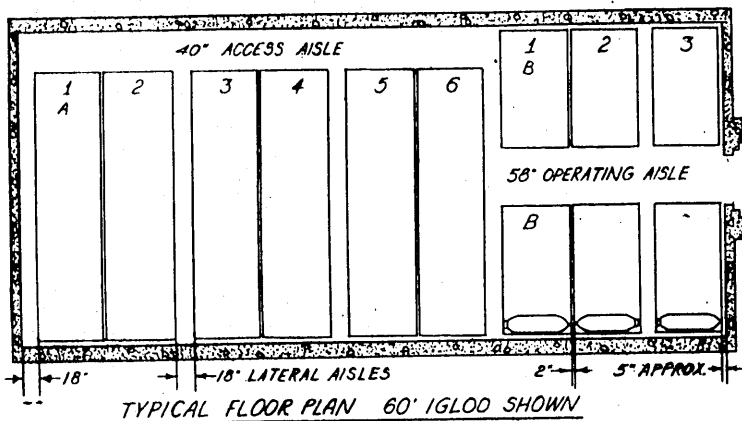

BOMB, S.A.P. (2000 LBS.) AND SHIPPING BANDS ON WOODEN DUNNAGE

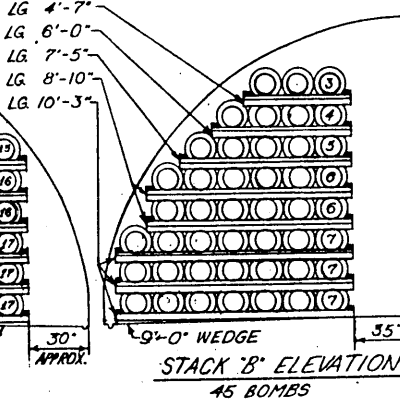
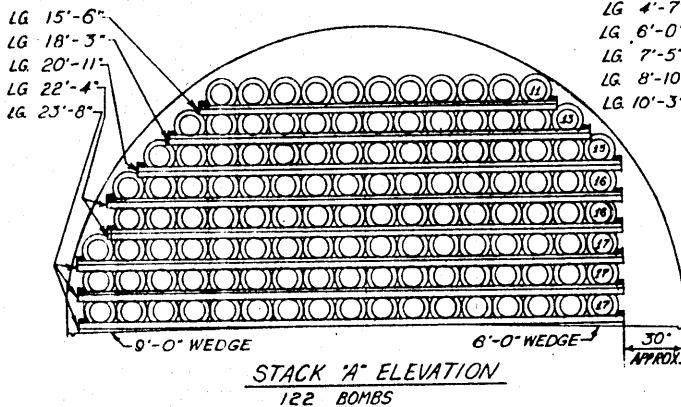
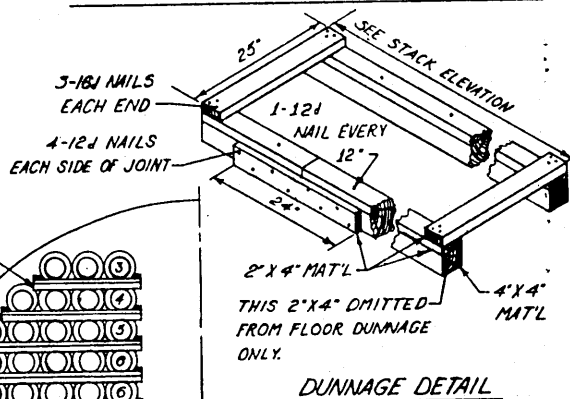
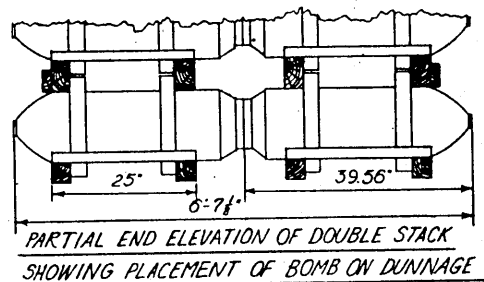
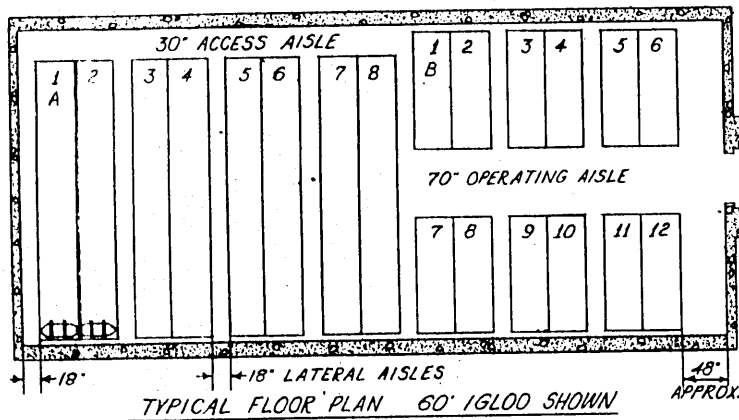

BOMB, T.I. (250 LBS.) WITH SHIPPING BANDS ON WOODEN DUNNAGE

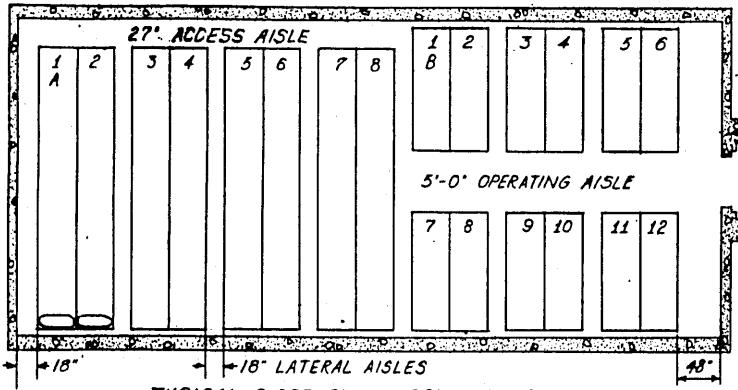

TYPICAL FLOOR PLAN 60' IGL00 SHOWN

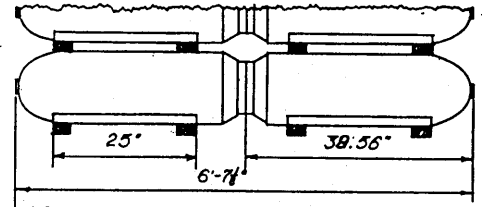

DETAIL SHOWING PLACEMENT OF BOMBS ON DUNNAGE

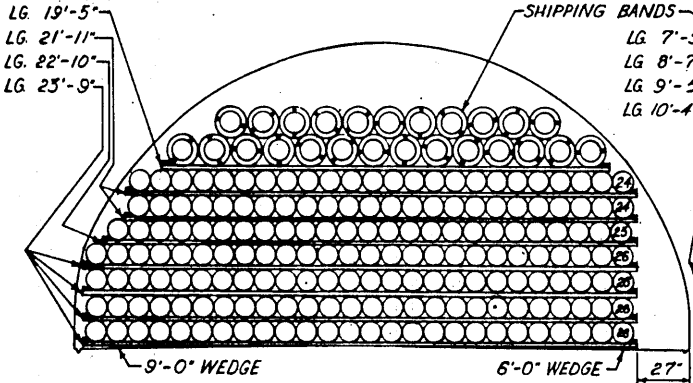

STACK 'A' ELEVATION
177 BOMBS

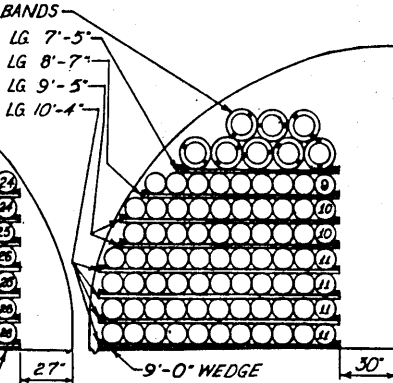

STACK 'B' ELEVATION
73 BOMBS

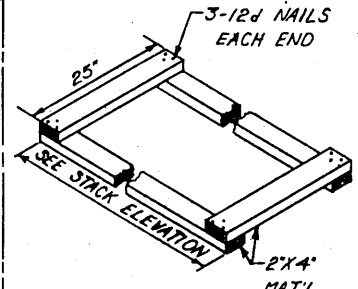

DUNNAGE DETAIL

BOMB, T.I., (250 LBS.) AND SHIPPING BANDS ON WOODEN DUNNAGE

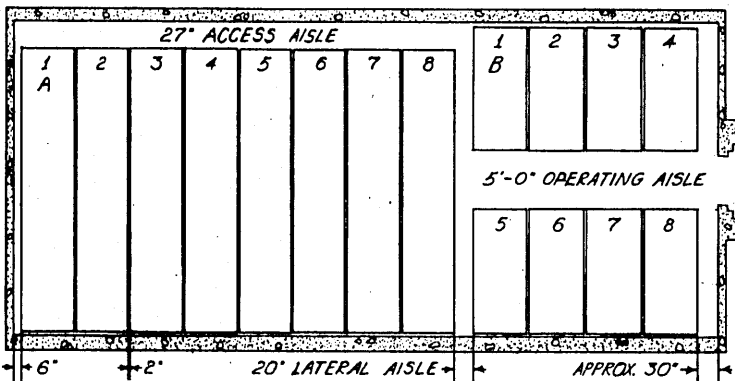

TYPICAL FLOOR PLAN 60' IGL00 SHOWN

NOTE:
SIZE OF DRUM SHOWN HEREON IS 34 1/2" IN LENGTH AND 20 1/2" IN DIAMETER.

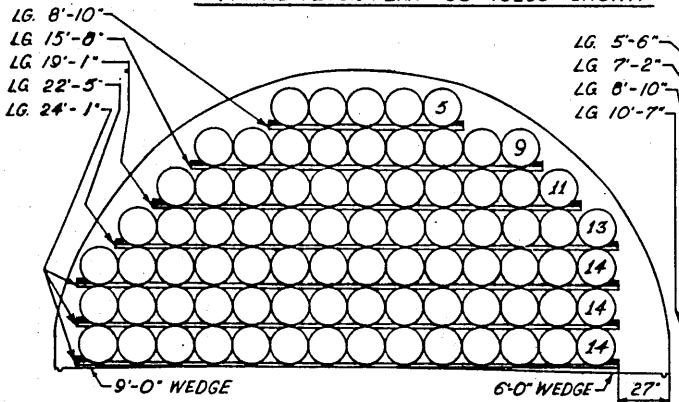

STACK 'A' ELEVATION
60 BOMBS

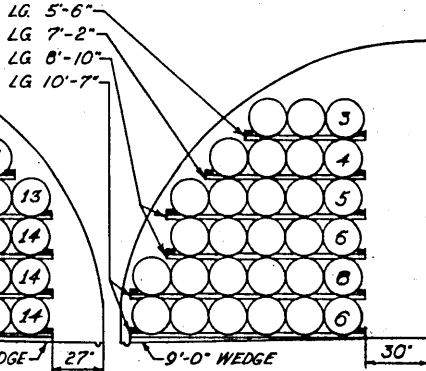

STACK 'B' ELEVATION
29 BOMBS

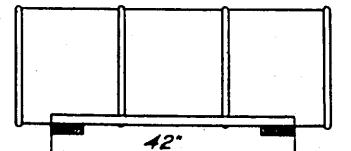

PLACEMENT OF BOMB ON WOOD DUNNAGE DETAIL

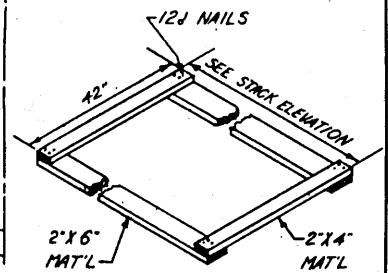

DUNNAGE DETAIL

BOMB, CLUSTER, FRAG. (500 LBS.) ON WOODEN DUNNAGE

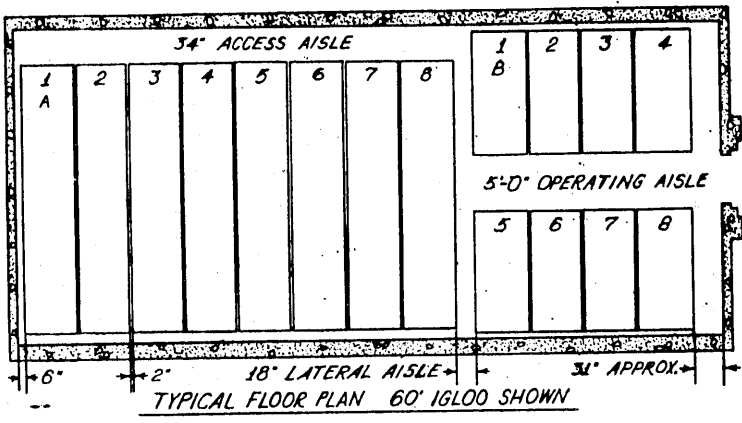

NOTE:
 SIZE OF DRUM SHOWN HEREON IS 54" IN LENGTH AND 24" IN DIAMETER.

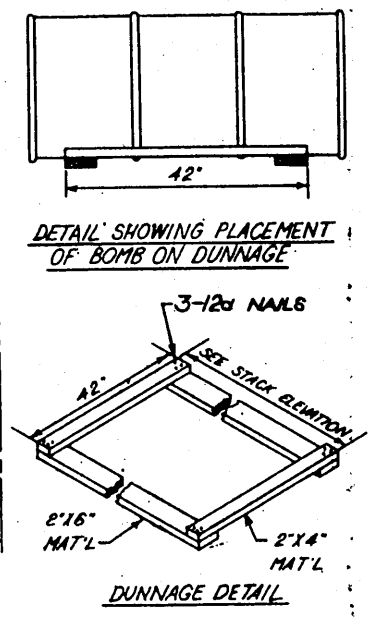
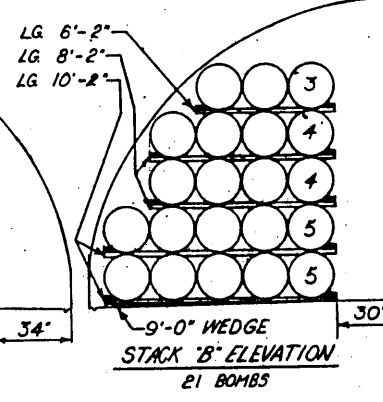
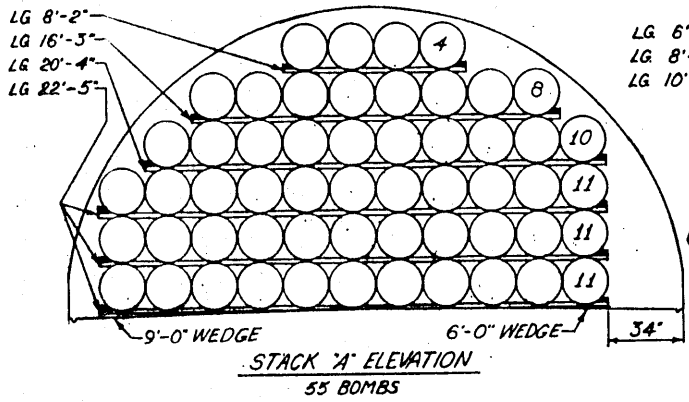

BOMB CLUSTER, FRAG. (500 LBS.) ON WOODEN DUNNAGE

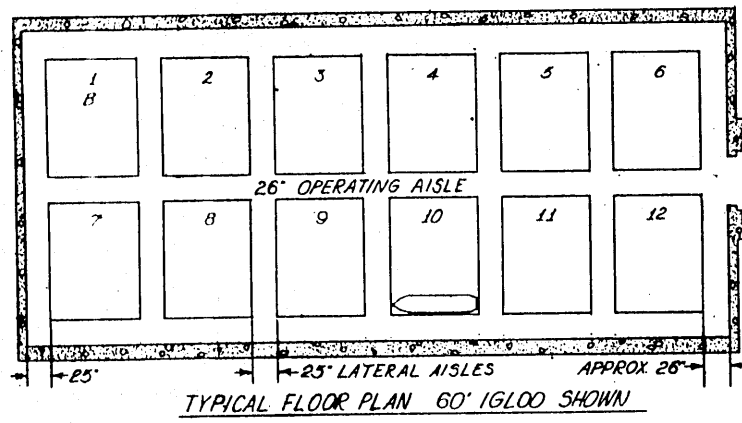

NOTE:
 THIS METHOD IS ALTERNATE TO THAT METHOD SHOWN ON PAGE 13.

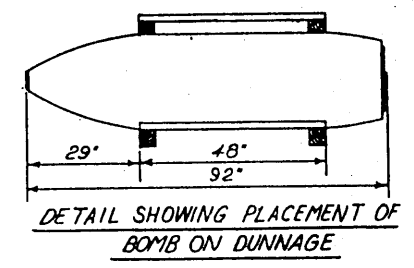

BOMBS SHOWN IN DOTTED LINES MAY BE ADDED TO STACKS IN MAGAZINES OF 500,000 LB EXPLOSIVE LIMIT.

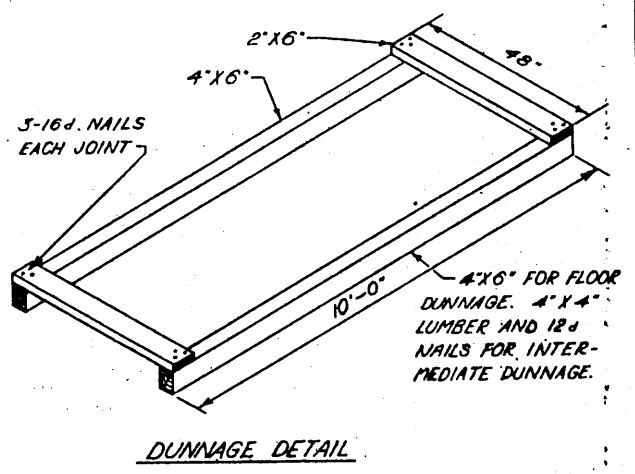
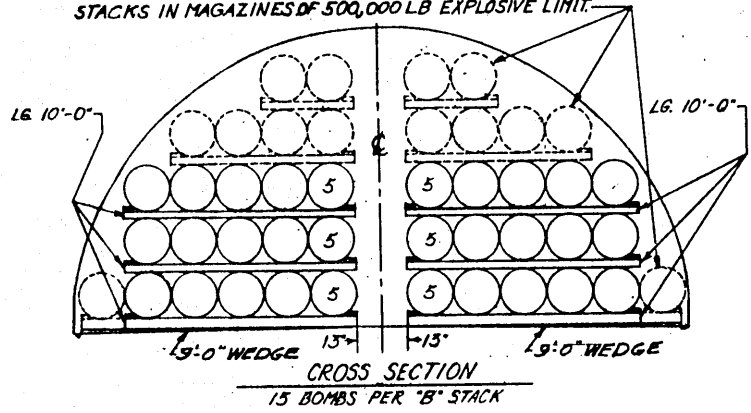

BOMB DEMO, (3000 LBS.) T55, FOR STORAGE BY CONVEYOR OR FORK LIFT

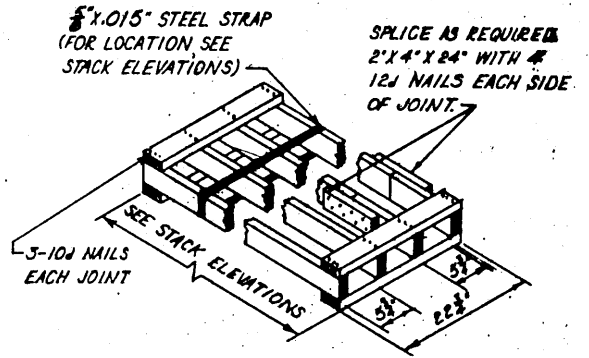
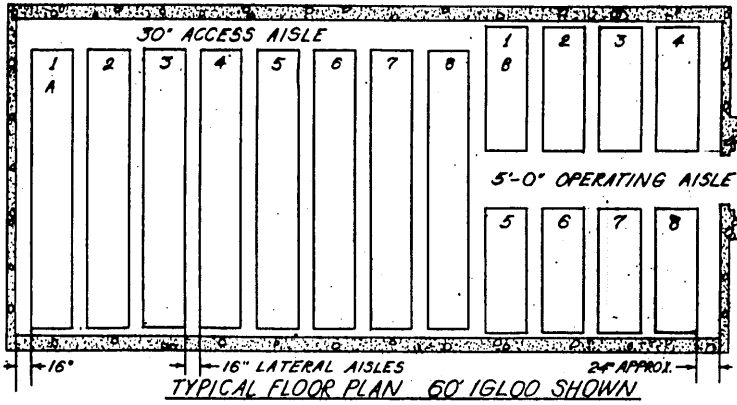

DUNNAGE DETAIL
MAT'L. 2' X 4' (ALT. 2' X 3')

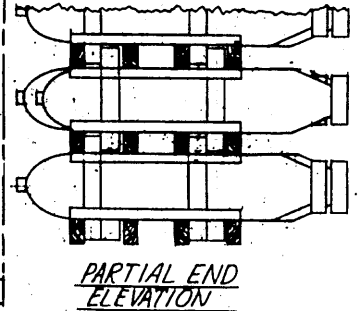
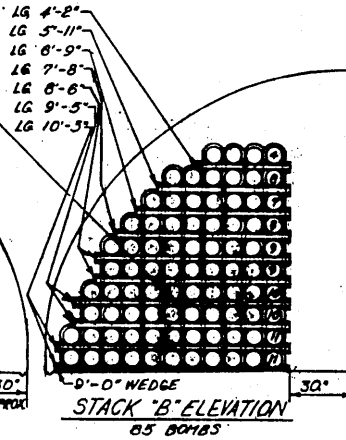
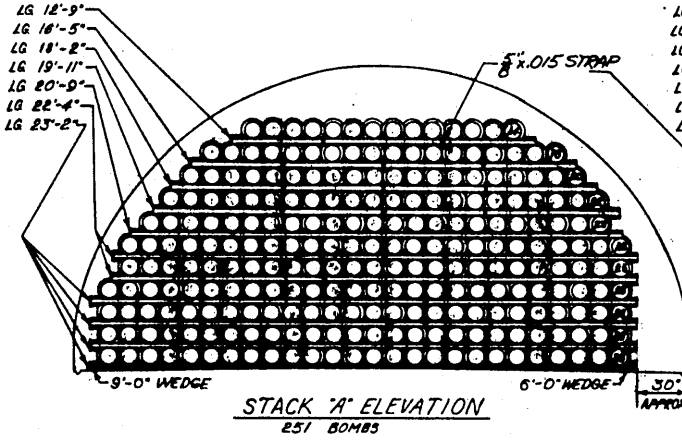

BOMB, PHOTOFLASH, (150 LBS.) WITH SHIPPING BANDS ON WOOD DUNNAGE

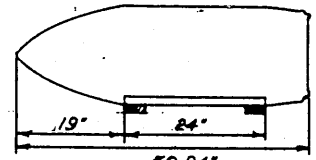
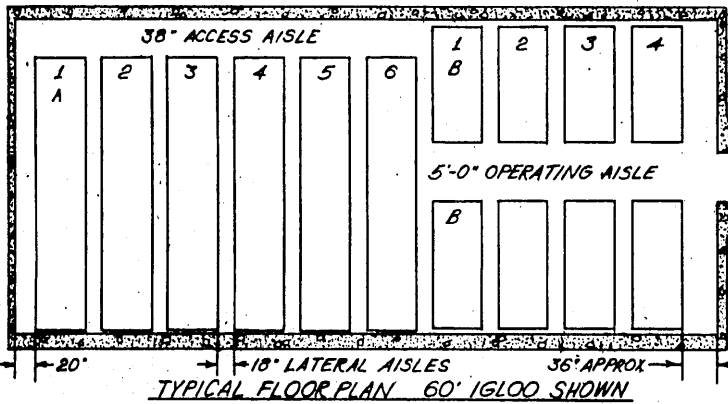

DETAIL SHOWING PLACEMENT
OF BOMB ON DUNNAGE

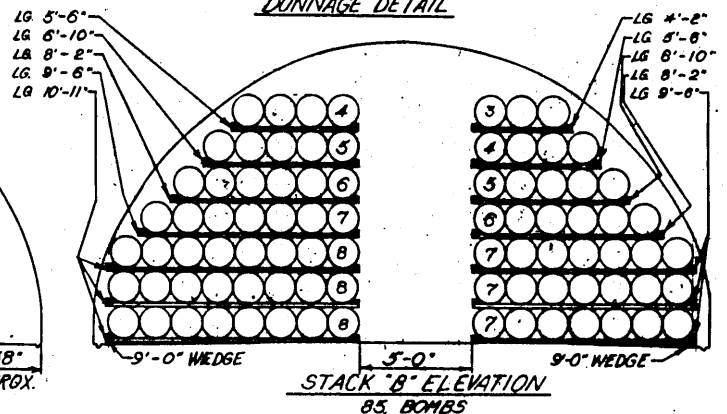
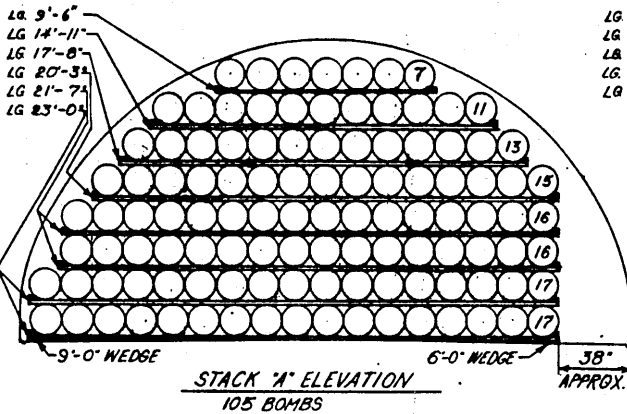
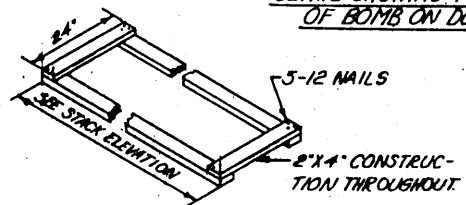

BOMB, DEMO., (750 LBS.) ON WOOD DUNNAGE

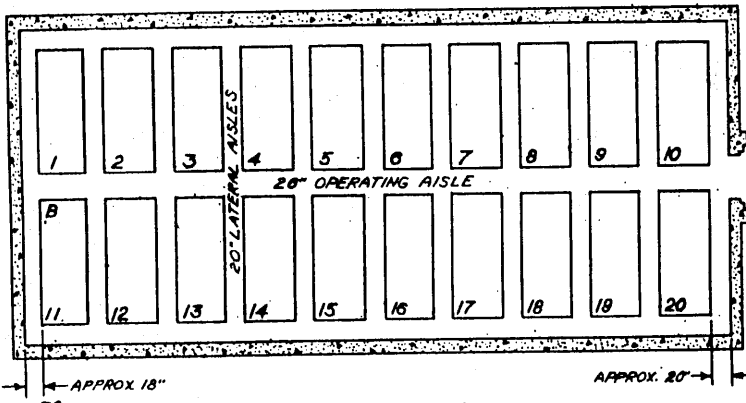

TYPICAL FLOOR PLAN
60' BLOCK

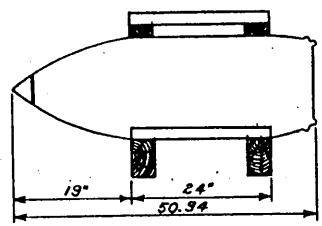

DETAIL SHOWING PLACEMENT
OF BOMB ON DUNNAGE

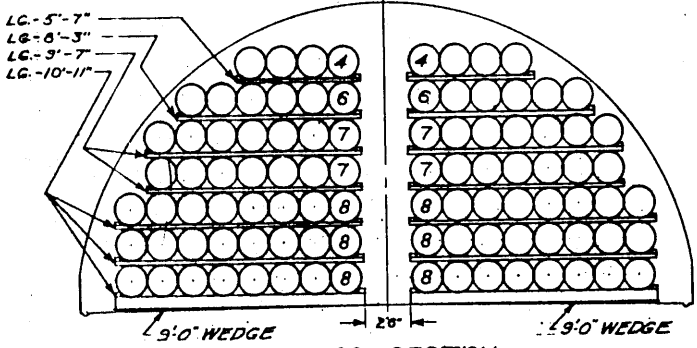

CROSS SECTION
48 BOMBS PER "B" STACK

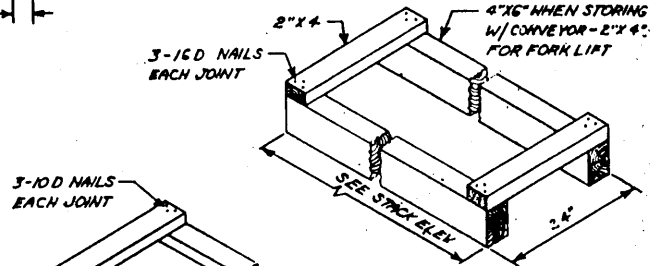

DETAIL - FLOOR DUNNAGE

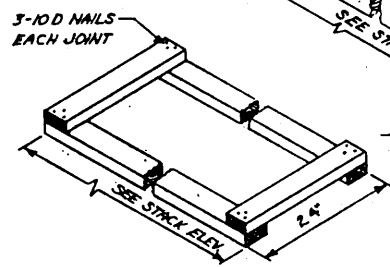

DETAIL - INTERMEDIATE DUNNAGE

BOMB, DEMO. 750LBS.

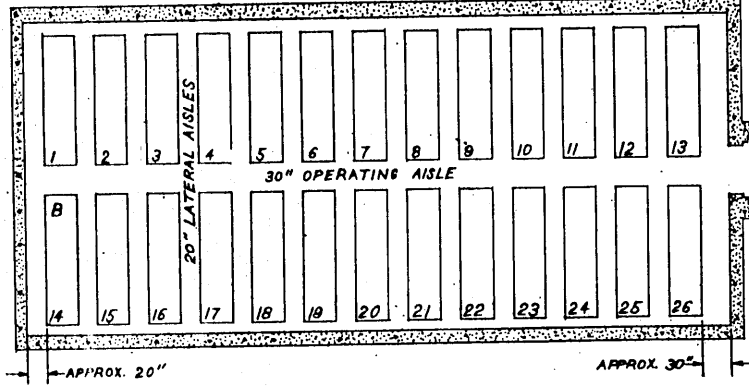

TYPICAL FLOOR PLAN
60' BLOCK

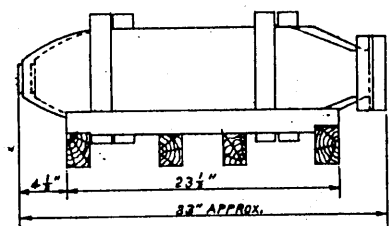

DETAIL SHOWING PLACEMENT
OF BOMB ON DUNNAGE

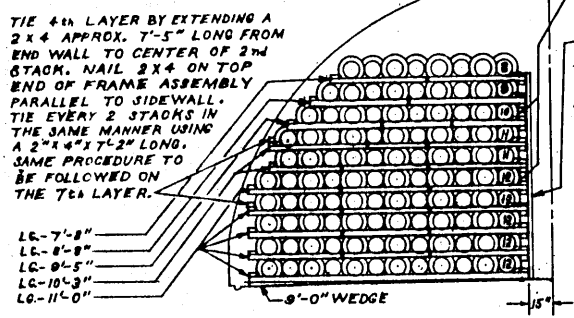

STACK "B" ELEVATION
108 BOMBS

TIE 5th & 8th LAYERS PARALLEL TO CENTER AISLE IN SAME MANNER AS AT SIDEWALL.
NAIL A 2x4 FROM THE BASE OF THE THIRD STACK TO THE TOP OF THE 2nd STACK FOR ADDITIONAL STABILITY. ABOVE PROCEDURE TO BE FOLLOWED THROUGHOUT 10LOO.

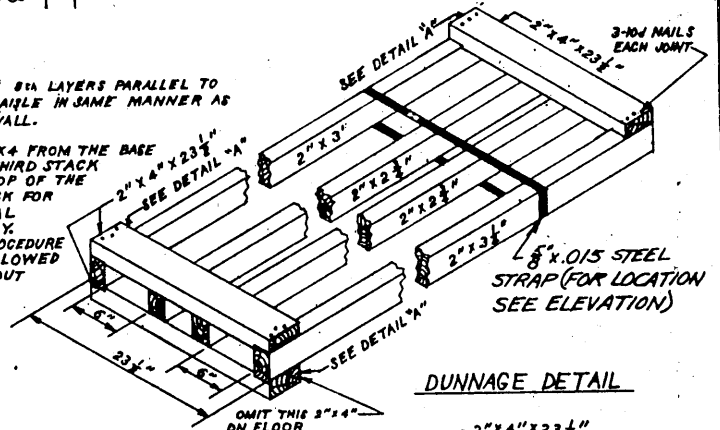

DUNNAGE DETAIL

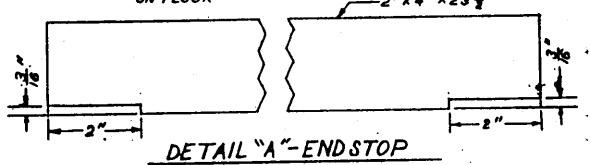

DETAIL "A" - END STOP

BOMB, G.P. (100 LBS.) WITH SHIPPING BANDS

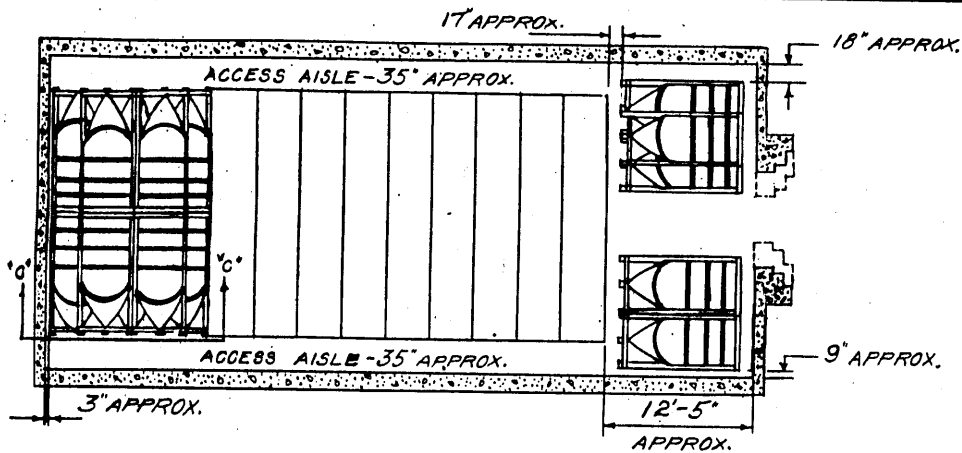

FLOOR PLAN-60' 16'00

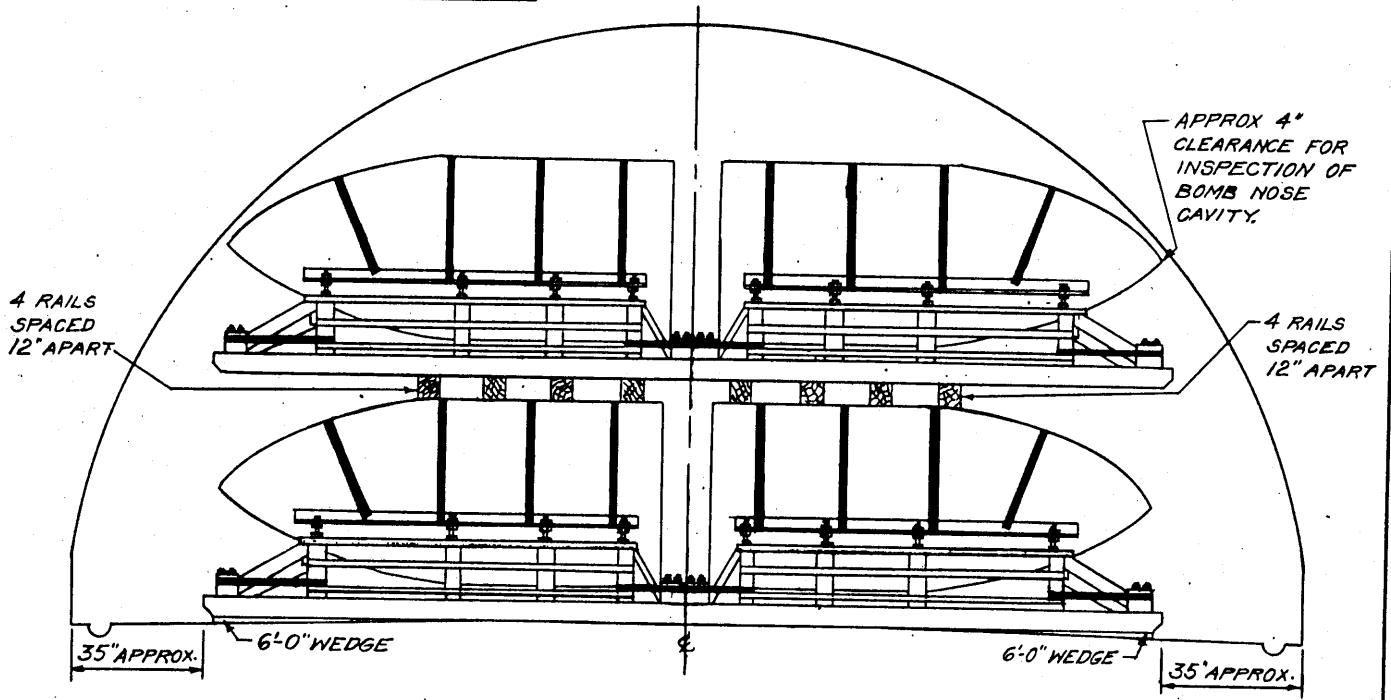

TYPICAL CROSS SECTION
(STACK 'A')

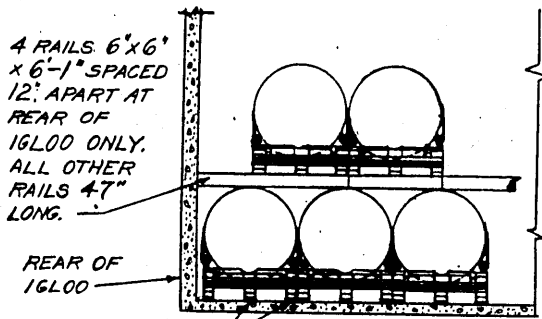

SECTION 'C-C'

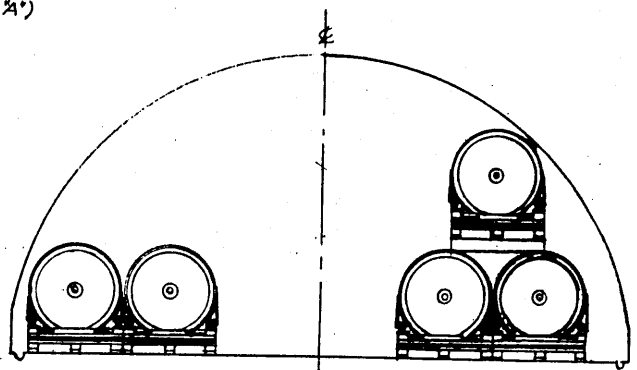

FRONT STACKING FOR 60' 16'00
(STACK 'B')

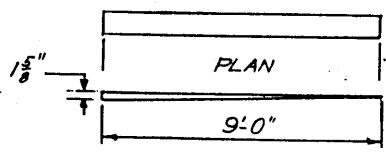

WEDGE DETAIL
(2x6" MAT'L)

NOTE:
FOR PACKING & MARKING OF PALLET SEE DWG. NO. 76-18-26
FOR DETAILS OF PALLET SEE DWG. NO. 76-18-27

NOTE:
THIS METHOD OF STORAGE IS ONLY PERMISSIBLE
WHERE SUITABLE M.H.E. IS AVAILABLE AND WHERE
STORAGE IS AUTHORIZED BY OCO TO 500,000 LBS.
EXPLOSIVE CAPACITY.

BOMB, 10,000 LBS.

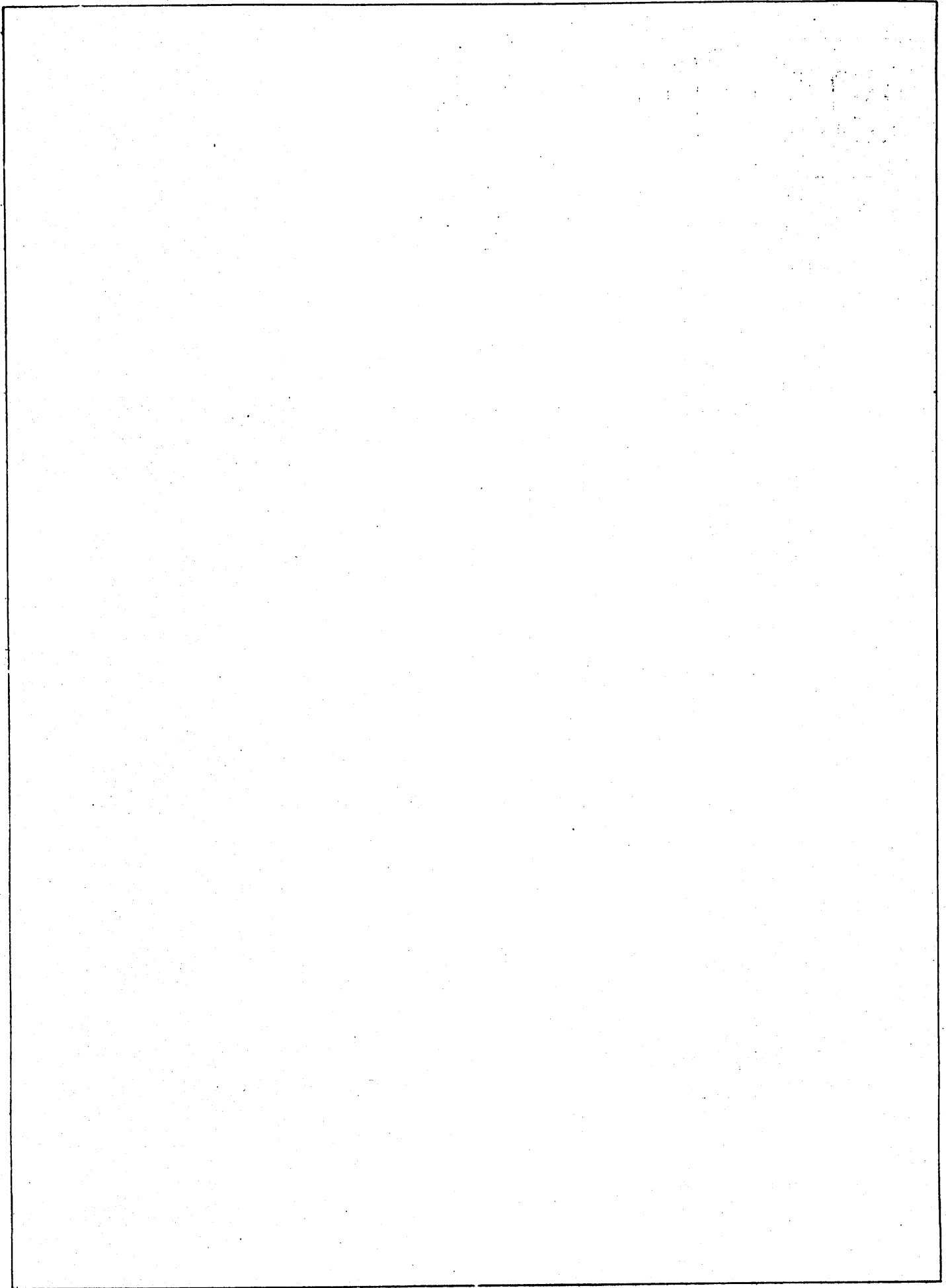

()

()

()

LINE	AIC SYMBOL	PACKING	LBS. EXPL PER PKG	PLANS ELEV. PAGE	STACKS/MAG.				PKGS/MAG.		EXPL/MAG.		MATERIALS PER STACK						
					60'		80'		60'	80'	60'	80'	A			B			
					A	B	A	B					BD FT. LBR	LBS NAILS	LBS STRAP	BD FT. LBR	LBS NAILS	LBS STRAP	
BOMB FRAG 4LB (WAFER)																			
1	SIDWB	3 WAFER INTL DRUM	14.7	4	24	23	31	31	5856	7719	86,084	113,470	79				79		
2	SIEQB	3 WAFER INTL DRUM	14.7	4	24	23	31	31	5856	7719	86,084	113,470	79				79		
3	SIERB	3 WAFER INTL DRUM	14.7	4	24	23	31	31	5856	7719	86,084	113,470	79				79		
4	SIESB	3 WAFER INTL DRUM	14.7	4	24	23	31	31	5856	7719	86,084	113,470	79				79		
5																			
6																			
7																			
BOMB FRAG. 90LB. (PALLETIZED)																			
8	SIELA	6/PALLET	11.4	4	42	5	59	6	13,740	19,068	156,636	217,376	34				23		
9	SIENA	6/PALLET	12.3	4	42	5	59	6	13,740	19,068	169,002	234,537	34				23		
10																			
11																			
BOMB FRAG 220 LB																			
12	SIETA	W/SHPG BAND	44.4	5	9	8	12	8	3133	3916	139,106	173,871	674	4.5	7.5	295	4.5	2.5	
13	SIETA	W/O SHPG BAND	44.4	5	9	10	12	4	5386	5630	239,139	249,972	432	5.5		197	4.5		
14																			
15																			
16																			
17																			
18																			
19																			
BOMB FRAG. 260 LB.																			
20	SIEFA	W/SHPG BAND	34.5	6	9	10	14	10	3109	5064	107,261	174,708	652	5.5		260	5.5	2.5	
21	SIEFA	W/O SHPG BAND	34.5	6	9	10	14	10	5168	7178	178,296	247,641	504	4		213	3.5	2.5	
22	SIEMA	W/SHPG BAND	36	6	9	10	14	10	3109	5064	111,924	182,304	652	5.5		260	5.5		
23	SIEMA	W/O SHPG BAND	36	6	9	10	14	8	5168	6,944	186,048	249,984	504	4		213	3.5		
24																			
25																			
26																			
27																			
BOMB, GP. 100 LB.																			
28	SIHYA	W/O SHPG BAND	53.8	7	10	6	10	7	4564	4646	245,544	249,955	227	2	50	120	2	25	
29	SIHHA	W/O SHPG BAND	57.4	7	10	5	10	5	4355	4355	249,977	249,977	227	2	50	120	2	25	
30	SIJGA	W/O SHPG BAND	56.6	7	10	6	10	6	4416	4416	249,946	249,946	227	2	50	120	2	25	
31	SIJHA	W/O SHPG BAND	53.3	7	10	6	10	7	4564	4690	243,262	249,977	227	2	50	120	2	25	
32	SIJIA	W/O SHPG BAND	53.3	7	10	6	10	7	4564	4690	243,262	249,977	227	2	50	120	2	25	
33																			
34																			
35																			
BOMB, GP 250 LB																			
36	SIHAA	W/SHPG BAND	126	7	8	10	11	4	1870	1984	235,620	249,984	555	5	6 1/2	336	6	2	
37	SIHAA	W/O SHPG BAND	126	8	7	11	11	1	1984	1984	249,984	249,984	201	1.5	50	122	1.5	16	
38	SIHSA	W/SHPG BAND	127	7	8	10	11	3	1870	1968	237,490	249,936	555	5	6 1/2	336	6	2	
39	SIHSA	W/O SHPG BAND	127	8	7	10	11	1	1968	1968	249,936	249,936	201	1.5	50	122	1.5	16	
40	SIINA	W/SHPG BAND	122	7	8	10	11	5	1870	2049	228,140	249,978	555	5	6 1/2	336	6	2	
41	SIINA	W/O SHPG BAND	122	8	7	11	11	2	2049	2049	249,978	249,978	201	1.5	50	122	1.5	16	
42	SIODA	W/SHPG BAND	136	7	8	10	11	1	1838	1838	249,968	249,968	555	5	6 1/2	336	6	2	
43	SIODA	W/O SHPG BAND	136	8	7	8	11		1838	1838	249,968	249,968	201	1.5	50	122	1.5	16	
44																			
45																			
46																			
47																			

LINE	A/C SYMBOL	PACKING	LBS EXPL PER PKG	PLANS ELEV'S PAGE	STACKS/MAG				PKGS/MAG		EXPL/MAG		MATERIALS PER STACK					
					60'		80'		60'	80'	60'	80'	A			B		
					A	B	A	B					BDFT LBR	LBS NAILS	LBS STRAP	BDFT LBR	LBS NAILS	LBS STRAP
BOMBS, DEMO. & GP, 500 LBS.																		
1	SIBIA	W/SHPG BND	266	8	7	5	9	1	939	939	249,774	249,774	452	2		240	2	
2	SIBIA	W/SHPG BND	266	9		22		22	939	939	249,774	249,774				95	1.5	10
3	SIHBA	W/SHPG BND	267	8	7	5	9	1	936	936	249,912	249,912	452	2		240	2	
4	SIHBA	W/SHPG BND	267	9		22		22	936	936	249,912	249,912				95	1.5	10
5	SIHFA	W/SHPG BND	262	8	7	6	9	1	954	954	249,948	249,948	452	2		240	2	
6	SIHFA	W/SHPG BND	262	9		22		23	946	945	247,852	249,948				95	1.5	10
7	SIHLA	W/SHPG BND	273	8	7	5	9		915	915	249,795	249,795	452	2		240	2	
8	SIHLA	W/SHPG BND	273	9		22		22	915	915	249,795	249,795				95	1.5	10
9	SIHTA	W/SHPG BND	266	8	7	5	9	1	939	939	249,774	249,774	452	2		240	2	
10	SIHTA	W/SHPG BND	266	9		22		22	939	939	249,774	249,774				95	1.5	10
11	SIHWA	W/SHPG BND	273	8	7	5	9		915	915	249,795	249,795	452	2		240	2	
12	SIHWA	W/SHPG BND	273	9		22		22	915	915	249,795	249,795				95	1.5	10
13	SIICA	W/SHPG BND	278	8	7	5	9		899	899	249,922	249,922	452	2		240	2	
14	SIICA	W/SHPG BND	278	9		21		21	899	899	249,922	249,922				95	1.5	10
15	SIIRA	W/SHPG BND	262	8	7	6	9	1	954	954	249,948	249,948	452	2		240	2	
16	SIIRA	W/SHPG BND	262	9		22		23	946	954	247,852	249,948				95	1.5	10
17	SIISA	W/SHPG BND	262	8	7	6	9	1	954	954	249,948	249,948	452	2		240	2	
18	SIISA	W/SHPG BND	262	9		22		23	946	954	247,852	249,948				95	1.5	10
19																		
20																		
21																		
22																		
BOMB, DEMO. & GP, 1000 LBS																		
23	SIBRA	W/SHPG BND	566	10	12	9	12	9	441	441	249,606	249,606	185	1.5		104	1.5	
24	SIBRA	W/SHPG BND	566	11		17		17	441	441	249,606	249,606				74	1.5	6
25	SIBSA	W/SHPG BND	538	10	12	10	12	10	464	464	249,632	249,632	185	1.5		104	1.5	
26	SIBSA	W/SHPG BND	538	11		18		18	464	464	249,632	249,632				74	1.5	6
27	SIHCA	W/SHPG BND	558	10	12	9	12	9	448	448	249,984	249,632	185	1.5		104	1.5	
28	SIHCA	W/SHPG BND	558	11		18		18	448	448	249,984	249,984				74	1.5	6
29	SIHGA	W/SHPG BND	548	10	12	10	12	10	456	456	249,888	249,888	185	1.5		104	1.5	
30	SIHGA	W/SHPG BND	548	11		18		18	456	448	249,888	249,888				74	1.5	6
31	SIHJA																	
32	SIHJA																	
33	SIHKA	W/SHPG BND	530	10	12	10	12	11	466	471	246,980	249,630	185	1.5		104	1.5	
34	SIHKA	W/SHPG BND	530	11		18		19	468	471	248,040	249,630				74	1.5	6
35	SIHMA	W/SHPG BND	573	10	12	9	12	9	436	436	249,828	249,828	185	1.5		104	1.5	
36	SIHMA	W/SHPG BND	573	11		17		17	436	436	249,828	249,828				74	1.5	6
37	SIHUA	W/SHPG BND	545	10	12	10	12	10	458	458	249,610	249,610	185	1.5		104	1.5	
38	SIHUA	W/SHPG BND	545	11		18		18	458	458	249,610	249,610				74	1.5	6
39	SIIAA	W/SHPG BND	560	10	12	9	12	9	446	446	249,760	249,760	185	1.5		104	1.5	
40	SIIAA	W/SHPG BND	560	11		18		18	446	446	249,760	249,760				74	1.5	6
41	SIIDA	W/SHPG BND	572	10	12	9	12	9	437	437	249,964	249,964	185	1.5		104	1.5	
42	SIIDA	W/SHPG BND	572	11		17		17	437	437	249,964	249,964				74	1.5	6
43	SIITA	W/SHPG BND	530	10	12	10	12	11	466	471	246,980	249,630	185	1.5		104	1.5	
44	SIITA	W/SHPG BND	530	11		18		19	468	471	248,040	249,630				74	1.5	6
45	SIIUA	W/SHPG BND	530	10	12	10	12	11	466	471	246,980	249,630	185	1.5		104	1.5	
46	SIIUA	W/SHPG BND	530	11		18		19	468	471	248,040	249,630				74	1.5	6
47	SIIXA	W/SHPG BND	530	10	12	10	12	11	466	471	246,980	249,630	185	1.5		104	1.5	
48	SIIXA	W/SHPG BND	530	11		18		19	468	471	248,040	249,630				74	1.5	6
49																		
50																		
51																		

LINE	AIC SYMBOL	PACKING	LBS. EXPL PER PKG	PLANS ELEV PAGE	STACKS MAG				PKGS. MAG		EXPL. MAG		MATERIALS PER STACK					
					60'		80'		60'	80'	60'	80'	A			B		
					A	B	A	B					BD FT LBR	LBS. NAILS	LBS STRAP	BD FT LBR	LBS NAILS	LBS STRAP
BOMB, DEMO F GP, 2000 LBS.																		
1	SICGA	W/SHPG BND	1133	12	6	2	6	2	220	220	249,260	249,260	300	2		112	0.5	
2	SICGA	W/O SHPG BND	1133	13	5		5		220	220	249,260	249,260	267	2		114	1.5	4
3	SICGA	W/SHPG BND	1076	12	6	2	6	2	232	232	249,652	249,652	300	2		112	0.5	
4	SICGA	W/O SHPG BND	1076	13	5	1	5	1	232	232	249,652	249,652	267	2		114	1.5	4
5	SIHDA	W/SHPG BND	1117	12	6	2	6	2	223	223	249,091	249,091	300	2		112	0.5	
6	SIHDA	W/O SHPG BND	1117	13	5	1	5	1	223	223	249,091	249,091	267	2		114	1.5	4
7	SIHIA	W/SHPG BND	1097	12	6	2	6	2	227	227	249,019	249,019	300	2		112	0.5	
8	SIHIA	W/O SHPG BND	1097	13	5	1	5	1	227	227	249,019	249,019	267	2		114	1.5	4
9	SIHNA	W/SHPG BND	1146	12	6	1	6	1	218	218	249,828	249,828	300	2		112	0.5	
10	SIHNA	W/O SHPG BND	1146	13	5		5		218	218	249,828	249,828	267	2		114	1.5	4
11	SIHVA	W/SHPG BND	1097	12	6	2	6	2	227	227	249,019	249,019	300	2		112	0.5	
12	SIHVA	W/O SHPG BND	1097	13	5	1	5	1	227	227	249,019	249,019	267	2		114	1.5	4
13	SIIEA	W/SHPG BND	1140	12	6	2	6	2	219	219	249,660	249,660	300	2		112	0.5	
14	SIIEA	W/O SHPG BND	1140	13	5		5		219	219	249,660	249,660	267	2		114	1.5	4
15	SIIVA	W/SHPG BND	1161	12	6	2	6	3	232	235	246,152	246,152	300	2		112	0.5	
16	SIIVA	W/O SHPG BND	1161	13	5	1	5	1	235	235	249,335	249,335	267	2		114	1.5	4
17	SIIWA	W/SHPG BND	1061	12	6	2	6	3	232	235	246,152	249,335	300	2		112	0.5	
18	SIIWA	W/O SHPG BND	1061	13	5	1	5	1	235	235	249,335	249,335	267	2		114	1.5	4
19	SI00A	W/SHPG BND	1183	12	6	2	6	2	230	230	249,090	249,090	300	2		112	0.5	
20	SI00A	W/O SHPG BND	1183	13	5	1	5	1	230	230	249,090	249,090	267	2		114	1.5	4
21																		
22																		
23																		
24																		
BOMB, DEMO, 3000 LBS.																		
25	SIJAA		1917	13	5		5		130	130	249,210	249,210	153	1.5				
26	SIJBA		1917	13	5		5		130	130	249,210	249,210	153	1.5				
27	SIJPA		1710	13	5		5		146	146	249,660	249,660	248	2.25				
28																		
29																		
30																		
31																		
BOMB LG, 4000 LBS																		
32	SICBA	W/SHPG BND	3244	14	4	4	5	3	77	77	249,788	249,788	152	1.5		66	1	
33	SICDA	W/SHPG BND	3237	14	4	4	5	3	77	77	249,249	249,249	152	1.5		66	1	
34	SICTA	W/SHPG BND	3361	14	4	4	5	2	74	74	248,714	248,714	152	1.5		66	1	
35																		
36																		
37																		
38																		
BOMB, 10,000 LBS																		
39	SIJCA	1/PALLET	8215	22A	12	1	15	1	51	60	418,965	492,906	108			108		
40	SIJDA	1/PALLET	8215	22A	12	1	15	1	51	60	418,965	492,906	108			108		
41	SIJFA	1/PALLET	8215	22A	12	1	15	1	51	60	418,965	492,906	108			108		
42																		
BOMB, GP, 12,000 LBS.																		
43	SI0SA		5500	15	5		6		40	45	220,000	247,500						
44	SI0WA		5500	15	5		6		40	45	220,000	247,500						
45																		
BOMB, GP, 12,000 PALLETIZED																		
46	SI0SA	1/PALLET	5500	3	12	1	15	1	38	45	209,000	247,500	60			60		
47	SI0WA	1/PALLET	5500	3	12	1	15	1	38	45	209,000	247,500	60			60		

LINE	AIC SYMBOL	PACKING	LBS EXPL PER PKG	PLANS EZEVS PAGE	STACKS/MAG				PKGS/MAG		EXPL/MAG		MATERIALS PER STACK					
					60'		80'		60'	80'	60'	80'	A			B		
					A	B	A	B					BFFT LBR	LBS NAILS	LBS STRAP	BFFT LBR	LBS NAILS	LBS STRAP
BOMB, SAP, 500 LBS																		
1	SIDEA	W/SHPG BND	160	15	8	8	12	2	1368	1562	218,880	249,920	584	2		230	2	
2	SIDEA	W/SHPG BND	160	16	8	3	8	3	1562	1562	249,920	249,920	289	2	16	126	2	8
3	SIDEA	W/SHPG BND	155	15	8	8	12	3	1368	1612	212,040	249,860	584	2		230	2	
4	SIDEA	W/SHPG BND	155	16	8	4	8	4	1612	1612	249,860	249,860	289	2	16	126	2	8
5	SIDLA	W/SHPG BND	151	15	8	8	12	4	1368	1655	206,568	249,905	584	2		230	2	
6	SIDLA	W/SHPG BND	151	16	8	5	8	5	1655	1655	249,905	249,905	289	2	16	126	2	8
7	SIDPA	W/SHPG BND	142	15	8	8	12	6	1368	1760	194,266	249,920	584	2		230	2	
8	SIDPA	W/SHPG BND	142	16	8	6	8	6	1760	1760	249,920	249,920	289	2	16	126	2	8
9	SIRAA	W/SHPG BND	145	15	8	8	12	5	1368	1724	198,360	249,980	584	2		230	2	
10	SIRAA	W/SHPG BND	145	16	8	6	8	6	1724	1724	249,980	249,980	289	2	16	126	2	8
11																		
12																		
13																		
14																		
15																		
16																		
BOMB, SAP, 1000 LBS																		
17	SIDFA	W/SHPG BND	312	16	7	8	9	5	758	801	234,000	249,912	500	1.5		216	1.5	
18	SIDFA	W/SHPG BND	312	17	7	2	7	2	801	801	249,912	249,912	226	1.5	13	92	1.25	5
19	SIDOA	W/SHPG BND	310	16	7	8	9	5	750	806	232,500	249,860	500	1.5		216	1.5	
20	SIDOA	W/SHPG BND	310	17	7	3	7	3	806	806	249,860	249,860	226	1.5	13	92	1.25	5
21	SIREA	W/SHPG BND	313	16	7	8	9	5	750	795	234,750	249,774	500	1.5		216	1.5	
22	SIREA	W/SHPG BND	313	17	7	2	7	2	798	798	249,774	249,774	226	1.5	13	92	1.25	5
23																		
24																		
25																		
26																		
27																		
28																		
29																		
30																		
BOMB, SAP, 2000 LBS.																		
31	SIDRA	W/SHPG BND	556	17	6	6	9		414	449	230,184	249,644	394	1.5		157	1.5	
32	SIDRA	W/SHPG BND	556	18	6	3	9		449	449	249,644	249,644	170	1.0	16	168	1.0	14
33	SIRIA	W/SHPG BND	556	17	6	6	9		414	449	230,184	249,644	394	1.5		157	1.5	
34	SIRIA	W/SHPG BND	556	18	6	3	9		449	449	249,644	249,644	170	1.0	16	168	1.0	14
BOMB, TI, 250 LBS																		
35	SIPJA	W/SHPG BND	71.9	18	8	12	10	12	1516	1716	109,001	126,544	719	7.0		249	2.5	
36	SIPJA	W/SHPG BND	71.9	19	8	12	10	12	2292	2646	190,245	190,245	280	1.5		130	1.5	
37	SIPKA	W/SHPG BND	63.6	18	8	12	10	12	1516	1716	96,418	119,36	719	7.		249	2.5	
38	SIPKA	W/SHPG BND	63.6	19	8	12	10	12	2292	2646	145,772	168,286	280	1.5		130	1.5	
39	SIPQA	W/SHPG BND		18														
40	SIPQA	W/SHPG BND		19														
41	SIPPA	W/SHPG BND		18														
42	SIPPA	W/SHPG BND		19														
43	SIPQA	W/SHPG BND		18														
44	SIPQA	W/SHPG BND		19														
45	SIPRA	W/SHPG BND		18														
46	SIPRA	W/SHPG BND		19														
47	SIPSA	W/SHPG BND		18														
48	SIPSA	W/SHPG BND		19														
49																		

LINE	AIC SYMBOL	PACKING	LBS. EXPL PER FRG.	PLANS ELEVS PAGE	STACKS/MAG.				FRGS/MAG.		EXPL/MAG		MATERIALS PER STACK					
					60'		80'		60'	80'	60'	80'	A			B		
					A	B	A	B					BD FT LBR	LBS NAILS	LBS STRAP	BD FT LBR	LBS NAILS	LBS STRAP
BOMB, TI, 250 LB.																		
1	SIPTA	W/SHPG BND		18														
2	SIPTA	W/O SHPG BND		19														
3	SIPUA	W/SHPG BND	57.3	18	8	12	10	12	1516	1760	86,867	100,848	719	7	249	2.5		
4	SIPUA	W/O SHPG BND	57.3	19	8	12	10	12	2296	2646	131,332	151,616	280	15	130	1.5		
5	SISMA	W/SHPG BND		18														
6	SISMA	W/O SHPG BND		19														
7	SISNA	W/SHPG BND		18														
8	SISNA	W/O SHPG BND		19														
9	SISRA	W/SHPG BND		18														
10	SISRA	W/O SHPG BND		19														
11	SISRA	W/SHPG BND		18														
12	SISRA	W/O SHPG BND		19														
13	SISTA	W/SHPG BND		18														
14	SISTA	W/O SHPG BND		19														
15																		
16																		
17																		
BOMB, CLUSTER, FRAG. 500 LB (MTL. DRUM 24 3/8" DIA.)																		
18	SIVPB	MTL DRUM	54	20	8	8	10	8	608	718	32,832	37,772	267	1.25	119	1.0		
19																		
20																		
21																		
BOMB, PHOTOFLASH 150-LB.																		
22	SILHA	W/SHPG BND	69.4	21	8	8	10	8	2688	3190	168,548	221,386	651	5.5	263	5.5		
23	SILLA	W/SHPG BND	69.4	21	8	8	10	8	2688	3190	168,548	221,386	651	5.5	263	5.5		
24																		
25																		
BOMB DEMO. 3000 LB. (CENTER AISLE METHOD)																		
26	SIJAA		1917	20		9		9	130	130	249,210	249,210			184	2.0		
27	SIJBA		1917	20		9		9	130	130	249,210	249,210			184	2.0		
28	SIJPA		1710	20		9		9	146	146	249,660	249,660			200	2.0		
29																		
30																		
31																		
BOMB, DEMO. 750 LB. (SIDE AISLE METHOD)																		
32	SIJLA		386	21	6		6		647	647	249,742	249,742	234	1.25	193	2.25		
33																		
34																		
35																		
BOMB, DEMO. 750 LB. (CENTER AISLE METHOD)																		
36	SIJLA		386	22		14		14	647	647	249,742	249,742			136	1.5		
37																		
38																		
39																		
BOMB GP, 100 LB (CENTER AISLE METHOD)																		
40	SIHYA	W/SHPG BND	53.8	22		26		36	2834	3924	152,470	211,172			209	5.0		
41	SIHHA	W/SHPG BND	57.4	22		26		36	2834	3924	162,672	225,238			209	5.0		
42	SIJGA	W/SHPG BND	56.6	22		26		36	2834	3924	160,405	222,099			209	5.0		
43	SIJHA	W/SHPG BND	53.3	22		26		36	2834	3924	151,053	209,150			209	5.0		
44	SIJIA	W/SHPG BND	53.3	22		26		36	2834	3924	151,053	209,150			209	5.0		
45																		
46																		
47																		

