

APPENDIX 99C

UNITIZATION PROCEDURES FOR BOXED AMMUNITION AND COMPONENTS ON 4-WAY ENTRY PALLETS

SMOKE POT, FLOATING, M4A2, PACKED 1 PER
WOODEN BOX, UNITIZED 27 BOXES PER 40" X
48" PALLET; APPROX BOX SIZE 15-7/8" L X
14-5/8" W X 15-3/8" H

NOTICE: THIS APPENDIX CANNOT STAND ALONE BUT MUST BE USED IN CONJUNCTION WITH
THE BASIC UNITIZATION PROCEDURES DRAWING 19-48-4116-20PA1002.

DISTRIBUTION STATEMENT A.

APPROVED FOR PUBLIC RELEASE;
DISTRIBUTION IS UNLIMITED.

| U. S. ARMY MATERIEL COMMAND DRAWING | | | |
|---|---|---|---------------------------------------|
| APPROVED, U. S. ARMY INDUSTRIAL OPERATIONS COMMAND <i>NH</i> <i>David A. Perkowski</i> <i>David E. Otachuk</i> AMSTA-AR-ESK AMSIO-TMJ | DRAFTSMAN ENGINEER | INGEBORG DEPPE SANDRA M. SCHULTZ | |
| APPROVED BY ORDER OF COMMANDING GENERAL, U. S. ARMY MATERIEL COMMAND <i>Arthur N. Dziadko</i> U. S. ARMY DEFENSE AMMUNITION CENTER AND SCHOOL | SUPPLY ENGINEERING DIVISION | TRANSPORTATION ENGINEERING DIVISION | VALIDATION ENGINEERING DIVISION |
| | <i>T. J. Michik</i> | <i>W. Zurek</i> | <i>J. K. Koster</i> |
| | LOGISTICS ENGINEERING OFFICE <i>William F. Ernst</i> | | |
| | FEBRUARY 1986 | | |
| | CLASS | DIVISION | DRAWING |
| | REVISION NO. 1 | MARCH 1996 | |
| | SEE THE REVISION LISTING ON PAGE 2 | | |
| | 19 | 48 | 4116/ 99C |
| | | | 20PA 1002 |

DO NOT SCALE

| PALLET UNIT DATA | | | | |
|------------------|-------|-----------------------------|------------|-------------------|
| ITEMS INCLUDED | | HAZARD CLASS AND DIVISION ● | | APPROX WEIGHT LBS |
| NSN | DODIC | OD CLASS | COMP GROUP | |
| 1365-01-380-1678 | K511 | 1.4 | G | 1,405 |
| 00-598-5220 | K867 | 1.4 | G | 1,405 |

- HAZARD CLASSIFICATION DATA CONTAINED IN THE ABOVE CHART IS FOR GUIDANCE AND INFORMATIONAL PURPOSES ONLY. VERIFICATION OF THE SPECIFIED DATA SHOULD BE MADE BY CONSULTING THE MOST RECENT JOINT HAZARD CLASSIFICATION SYSTEM LISTING OR OTHER APPROVED LISTING(S).

REVISION

REVISION NO. 1, DATED MARCH 1996, CONSISTS OF:

1. ADDING ITEM BY NATIONAL STOCK NUMBER TO "PALLET UNIT DATA" CHART.
2. CHANGING HAZARD CLASS ON "PALLET UNIT DATA" CHART.
3. DELETING GENERAL NOTE RELATING TO STRAP CUTTER. ADDING GENERAL NOTES RELATING TO PRESERVATIVE TREATED DUNNAGE AND APPROXIMATE DIMENSIONS OF SPACER ASSEMBLIES. RE-LETTERING OTHER GENERAL NOTES.

GENERAL NOTES

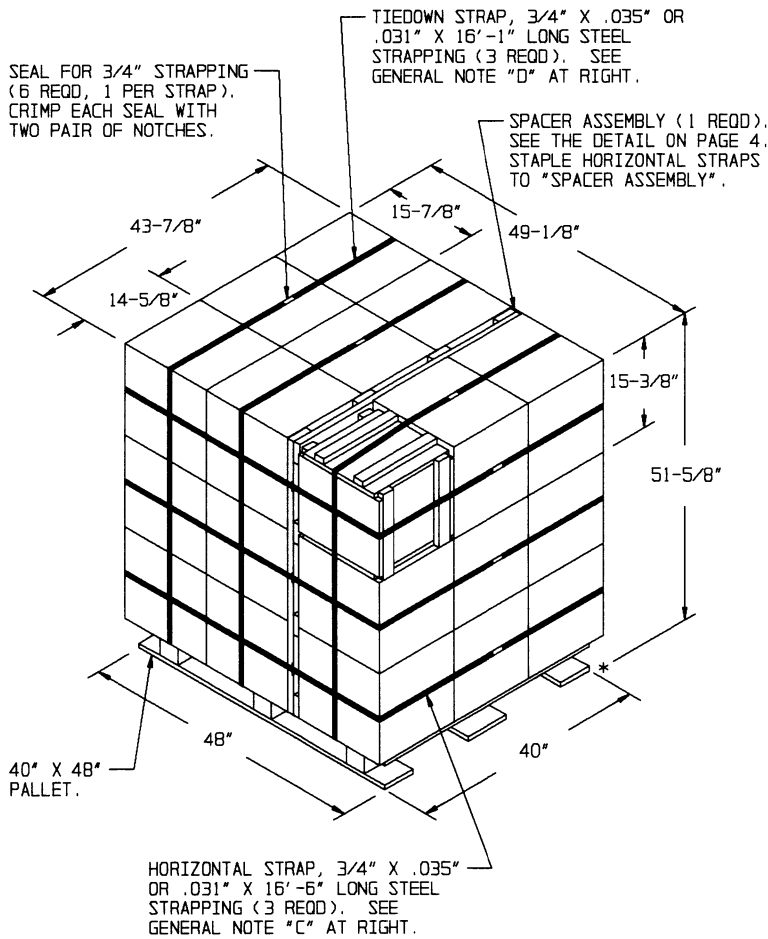

PALLET UNIT

SEE GENERAL NOTE "B" AT RIGHT.

| | | |
|--|-------|--------------------|
| 27 BOXES OF SMOKE POTS (1 PER BOX) AT 48 LBS | ----- | 1,296 LBS (APPROX) |
| DUNNAGE | ----- | 29 LBS |
| PALLET | ----- | 80 LBS |

| | | |
|--------------|-------|---------------------|
| TOTAL WEIGHT | ----- | 1,405 LBS (APPROX) |
| CUBE | ----- | 64.4 CU FT (APPROX) |

BILL OF MATERIAL

| LUMBER | LINEAR FEET | BOARD FEET |
|-------------------------|-------------|------------|
| 1" X 4" | 29.92 | 9.97 |
| NAILS | NO. REOD | POUNDS |
| 6d(2") | 32 | 0.19 |
| PALLET, 40" X 48" | 1 REOD | 80 LBS |
| STEEL STRAPPING, 3/4" | 97.75' REOD | 8.73 LBS |
| SEAL FOR 3/4" STRAPPING | 6 REOD | NIL |
| STAPLE, 15/16" X 3/4" | 6 REOD | NIL |

- A. THIS APPENDIX CANNOT STAND ALONE BUT MUST BE USED IN CONJUNCTION WITH THE BASIC UNITIZATION PROCEDURES DRAWING 19-48-4116-20PA1002. TO PRODUCE AN APPROVED UNIT LOAD, ALL PERTINENT PROCEDURES, SPECIFICATIONS AND CRITERIA SET FORTH WITHIN THE BASIC DRAWING WILL APPLY TO THE PROCEDURES DELINEATED IN THIS APPENDIX. ANY EXCEPTIONS TO THE BASIC PROCEDURES ARE SPECIFIED IN THIS APPENDIX.
- B. DIMENSIONS, CUBE AND WEIGHT OF A PALLET UNIT WILL VARY SLIGHTLY DEPENDING UPON THE ACTUAL DIMENSIONS OF THE BOXES AND THE WEIGHT OF THE SPECIFIC ITEM BEING UNITIZED.
- C. INSTALL EACH HORIZONTAL STRAP TO ENCIRCLE A LAYER OF BOXES ON THE PALLET. HORIZONTAL STRAPS MUST BE TENSIONED AND SEALED PRIOR TO THE APPLICATION OF TIEDOWN STRAPS.
- D. INSTALL EACH TIEDOWN STRAP TO PASS UNDER THE TOP DECK BOARDS OF THE PALLET AND TO BE LOCATED AS SHOWN. TIEDOWN STRAPS WILL NOT BE APPLIED UNTIL THE HORIZONTAL STRAPS HAVE BEEN TENSIONED AND SEALED.
- E. THE FOLLOWING AMC DRAWINGS ARE APPLICABLE FOR OUTLOADING AND STORAGE OF THE ITEMS COVERED BY THIS APPENDIX.
 - CARLOADING - - - - 19-48-4115-5PA1002
 - TRUCKLOADING - - - - 19-48-4117-11PA1003
 - STORAGE - - - - - 19-48-4118-1-2-3-4-14-22PA1002
 - END OPENING ISO CONTAINER - - - - 19-48-4153-15PA1002
 - MILVAN - - - - - 19-48-4166-15PA1003
 - SIDE OPENING ISO CONTAINER - - - - 19-48-4267-15PA1009
- F. IF ITEMS COVERED HEREIN ARE UNITIZED PRIOR TO ISSUANCE OF THIS APPENDIX, THE BOXES NEED NOT BE REUNITIZED SOLELY TO CONFORM TO THIS APPENDIX.
- G. THE UNITIZATION PROCEDURES DEPICTED HEREIN MAY ALSO BE USED FOR UNITIZING SMOKE POTS WHEN IDENTIFIED BY DIFFERENT NATIONAL STOCK NUMBERS (NSN) THAN WHAT IS SHOWN ON PAGE 2, PROVIDED THE BOX PACK DOES NOT VARY FROM WHAT IS DELINEATED HEREIN. THE EXPLOSIVE CLASSIFICATION OF OTHER ITEMS MAY BE DIFFERENT THAN WHAT IS SHOWN.
- H. THE STYLE 1 PALLET DELINEATED IN THE DETAIL AT LEFT NEED NOT HAVE CHAMFERS OR STRAP SLOTS AS SPECIFIED WITHIN MILITARY SPECIFICATION MIL-P-15011 WHEN USED FOR THE UNITIZATION OF ITEMS COVERED BY THIS APPENDIX.
- J. WHEN THE UNIT LOAD DEPICTED AT LEFT IS TO BE USED FOR UNITIZING MARINE CORPS AMMUNITION, ONE LAYER OF BOXES MUST BE OMITTED, TIEDOWN STRAP LENGTHS MUST BE DECREASED TO 13'-7", ONE HORIZONTAL STRAP MUST BE OMITTED, AND THE SPACER ASSEMBLY MUST BE MODIFIED. SPACER ASSEMBLY MODIFICATIONS INCLUDE SHORTENING VERTICAL PIECES TO 30", AND OMITTING A HORIZONTAL PIECE. THIS WILL RESULT IN AN OVERALL UNIT HEIGHT OF 36-1/4", A GROSS UNIT WEIGHT OF 966 POUNDS, AND A UNIT CUBE OF 45.2 CUBIC FEET. ADDITIONALLY, THE UNIT MAY BE MODIFIED AS DESCRIBED WHEN BEING SHIPPED BY MILVAN OR COMMERCIAL INTERMODAL FREIGHT CONTAINER. THE DETERMINATION TO REDUCE THE LOAD BY A LAYER FOR TRANSPORTATION WILL BE MADE BY THE RESPONSIBLE COMMAND AND WILL BE BASED UPON ECONOMICS OF TRANSPORTATION AND HANDLING.
- K. ALL DUNNAGE SHALL BE PRESERVATIVE TREATED IN ACCORDANCE WITH GENERAL NOTE "AA" IN THE BASIC PROCEDURES.
- L. DIMENSIONS OF THE SPACER ASSEMBLIES ARE APPROXIMATE AND MUST BE VERIFIED IN ACCORDANCE WITH GENERAL NOTE "Z" IN THE BASIC PROCEDURES. THESE ASSEMBLIES MUST NOT PROTRUDE PAST THE TOPS AND/OR SIDES OF THE CONTAINERS.

TIE PIECE, 1" X 4" X BOX WIDTH (2 REQD).
 NAIL TO LONGITUDINAL PIECES W/2-6d NAILS
 AT EACH END AND TO LATERAL PIECE W/2-6d
 NAILS.

VERTICAL PIECE,
 2" X 4" X BOX
 HEIGHT MINUS
 3/4" (4 REQD).

BOX WIDTH

BOX LENGTH

BOX HEIGHT

SUPPORT PIECE, 2" X 4"
 X CUT-TO-FIT (2 REQD).
 NAIL TO VERTICAL PIECE
 W/2-10d NAILS. NOTE:
 WHEN A FILLER ASSEMBLY
 IS LOCATED IN AN OUTER
 STACK ON A 48" SIDE OF
 THE PALLET, "SUPPORT
 PIECES" MUST BE POSI-
 TIONED AS SHOWN.

STRAP BEARING PIECE,
 2" X 4" X BOX WIDTH
 MINUS 3" (AS REQD).
 NAIL TO VERTICAL
 PIECES W/2-10d NAILS
 AT EACH END. NOTE:
 WHEN A FILLER ASSEMBLY
 IS LOCATED IN AN OUTER
 STACK ON A 40" SIDE OF
 THE PALLET A "STRAP
 BEARING PIECE" MUST BE
 POSITIONED AS SHOWN.

FILLER ASSEMBLY
 (FOR MINUS ONE BOX)

LONGITUDINAL PIECE, 2" X 4" X
 BOX LENGTH (4 REQD). NAIL TO
 VERTICAL PIECES W/2-10d NAILS
 AT EACH END.

LATERAL PIECE, 2" X 4" X
 BOX WIDTH MINUS 3" (4 REQD).
 VERTICAL PIECES W/2-10d
 NAILS AT EACH END.

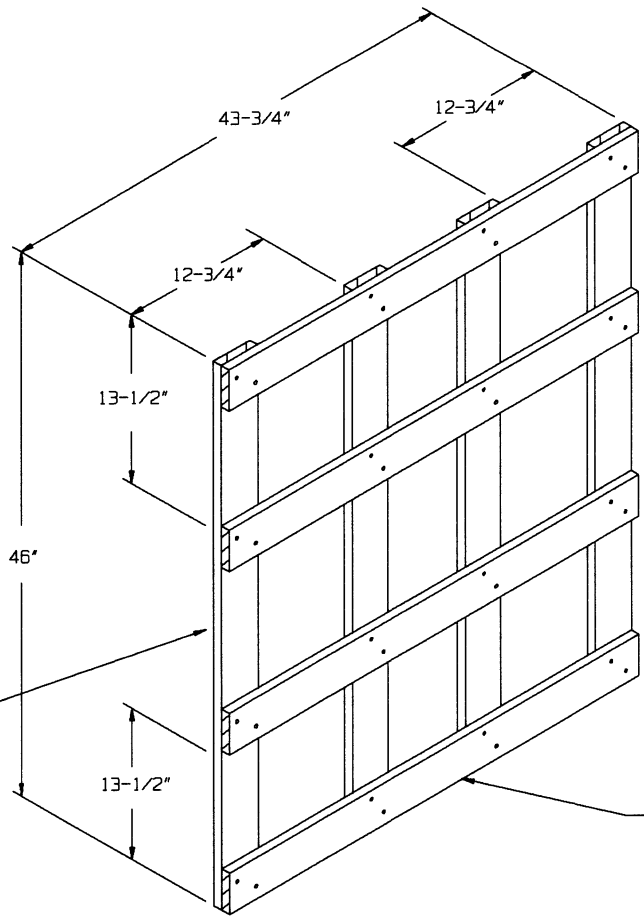

VERTICAL PIECE, 1" X 4"
 X 46" (4 REQD).

HORIZONTAL PIECE,
 1" X 4" X 43-3/4"
 (4 REQD). NAIL TO
 VERTICAL PIECES
 W/2-6d NAILS AT EACH
 JOINT AND CLINCH.

SPACER ASSEMBLY
 (1 REQD)