

APPENDIX 99A

UNITIZATION PROCEDURES FOR BOXED AMMUNITION AND COMPONENTS ON 4-WAY ENTRY PALLETS

SMOKE POT, PACKED 1 PER WOODEN BOX,
UNITIZED 12 BOXES PER 35" X 45 1/2" PALLET;
APPROX BOX SIZE 18 1/8" L X 16 5/8" W X 17 5/8" H

PALLET UNIT DATA						
ITEMS INCLUDED		HAZARD CLASSIFICATION				WEIGHT
NSN	DODIC	DOT CLASS	CG CLASS	QD CLASS	COMP GROUP	(LBS)
1365-01-096-1455	K867	C	II-E	1.3	G	670

NOTICE: THIS APPENDIX CANNOT STAND ALONE BUT MUST
BE USED IN CONJUNCTION WITH THE BASIC UNITIZATION
PROCEDURES DRAWING 19-48-4116-20PA1002.

REVISION

REVISION NO. 1, DATED OCTOBER 1981, CONSISTS OF:

1. CHANGING NATIONAL STOCK NUMBER IN "PALLET UNIT DATA" CHART.
2. CHANGING UNITIZATION PROCEDURES TO DEPICT REVISED BOX DIMENSIONS.

DO NOT SCALE

REVISIONS				DRAFTSMAN	PROJ ENG
1	OCT 81	<i>John L. Syndt</i>	<i>John L. Syndt</i>		
				CHECKER	LOG ENGR OFFICE
				APPROVED, U. S. ARMY ARMAMENT MATERIEL READINESS COMMAND	
				ORBAR - MAD	ORBAR - TMD
				APPROVED BY ORDER OF COMMANDING GENERAL, U. S. ARMY MATERIEL DEVELOPMENT AND READINESS COMMAND (DARCOM)	
				<i>John L. Syndt</i>	
				U. S. ARMY DEFENSE AMMUNITION CENTER AND SCHOOL	
				U. S. ARMY DARCOM DRAWING	
				JULY 1980	
				CLASS	DIVISION
				DRAWING	FILE
				19	48
				4116/ 99A	20PA 1002

GENERAL NOTES

- A. THIS APPENDIX CANNOT STAND ALONE BUT MUST BE USED IN CONJUNCTION WITH THE BASIC UNITIZATION PROCEDURES DRAWING 19-48-4116-20PA1002. TO PRODUCE AN APPROVED UNIT LOAD, ALL PERTINENT PROCEDURES, SPECIFICATIONS AND CRITERIA SET FORTH WITHIN THE BASIC DRAWING WILL APPLY TO THE PROCEDURES DELINEATED IN THIS APPENDIX. ANY EXCEPTIONS TO THE BASIC PROCEDURES ARE SPECIFIED IN THIS APPENDIX.
- B. DIMENSIONS, CUBE AND WEIGHT OF A PALLET UNIT WILL VARY SLIGHTLY DEPENDING UPON THE ACTUAL DIMENSIONS OF THE BOXES AND THE WEIGHT OF THE SPECIFIC ITEM BEING UNITIZED.
- C. THE LOAD STRAPS MAY BE THREADED THROUGH THE STRAP SLOTS OF A PALLET OR PRE-POSITIONED ON THE PALLET DECK PRIOR TO PLACING BOXES ON THE PALLET. LOAD STRAPS MUST BE TENSIONED AND SEALED PRIOR TO APPLICATION OF TIEDOWN STRAPS.
- D. INSTALL EACH TIEDOWN STRAP TO PASS UNDER THE TOP DECK BOARDS OF THE PALLET AND TO BE LOCATED AS SHOWN. TIEDOWN STRAPS WILL NOT BE APPLIED UNTIL THE LOAD STRAPS HAVE BEEN TENSIONED AND SEALED.
- E. THE FOLLOWING DARCOM DRAWINGS ARE APPLICABLE FOR OUT-LOADING AND STORAGE OF THE ITEMS COVERED BY THIS APPENDIX.
 CARLOADING----- DRAWING 19-48-4115-5PA1002.
 TRUCKLOADING ---- DRAWING 19-48-4117-11PA1003.
 STORAGE----- DRAWING 19-48-4118-1-2-3-4-14-22PA1002.
- F. FOR METHOD OF SECURING A STRAP CUTTER TO THE PALLET UNIT, SEE DARCOM DRAWING 19-48-4127-20P1000.
- G. IF ITEMS COVERED HEREIN ARE UNITIZED PRIOR TO ISSUANCE OF THIS APPENDIX, THE BOXES NEED NOT BE REUNITIZED SOLELY TO CONFORM TO THIS APPENDIX.
- H. THE UNITIZATION PROCEDURES DEPICTED HEREIN MAY ALSO BE USED FOR UNITIZING SMOKE POTS WHEN IDENTIFIED BY DIFFERENT NATIONAL STOCK NUMBERS (NSN) THAN WHAT IS SHOWN ON THE TITLE PAGE, PROVIDED THE BOX PACK DOES NOT VARY FROM WHAT IS DELINEATED HEREIN. THE EXPLOSIVE CLASSIFICATION OF OTHER ITEMS MAY BE DIFFERENT THAN WHAT IS SHOWN.

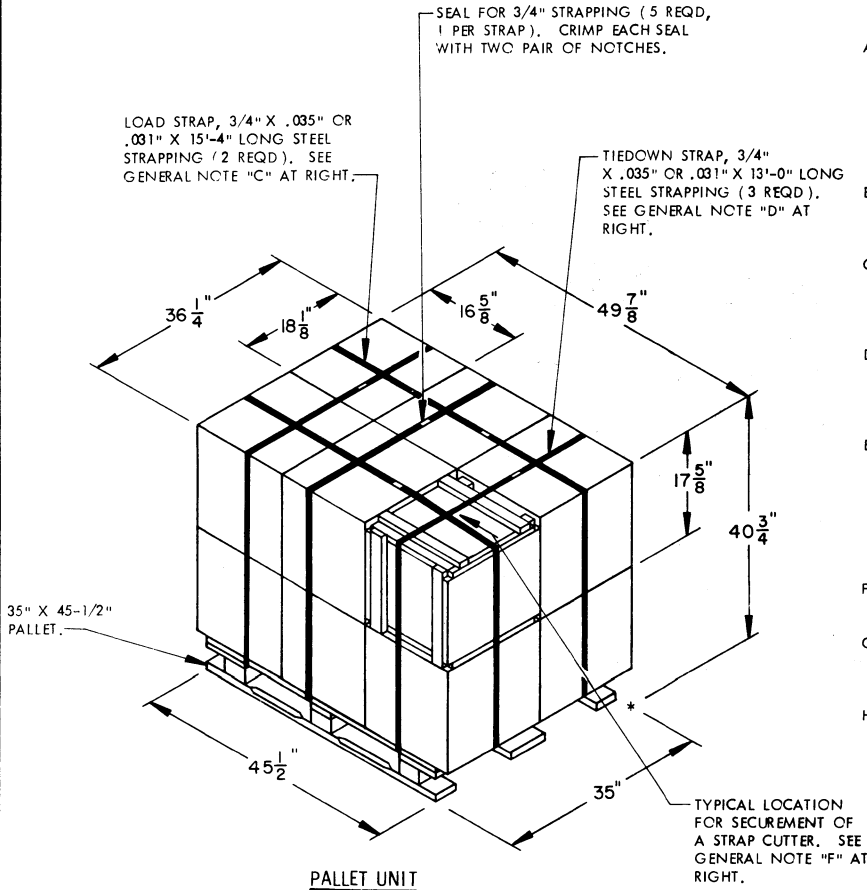

PALLET UNIT

SEE GENERAL NOTE "B" AT RIGHT.

12 BOXES OF SMOKE POT (1 PER BOX) @ 50 LBS -----	600 LBS (APPROX)
DUNNAGE -----	5 LBS
PALLET -----	65 LBS
<hr/>	
TOTAL WEIGHT -----	670 LBS (APPROX)
CUBE -----	42.6 CU FT (APPROX)

BILL OF MATERIAL	
PALLET, 35" X 45-1/2" -----	1 REQD ----- 65 LBS
STEEL STRAPPING, 3/4" -----	69.67' REQD ----- 4.98 LBS
SEAL FOR 3/4" STRAPPING -----	5 REQD ----- NIL

TIE PIECE, 1" X 4" X BOX WIDTH (2 REQD). NAIL TO LONGITUDINAL PIECES W/2-6d NAILS AT EACH END AND TO LATERAL PIECE W/1-6d NAIL

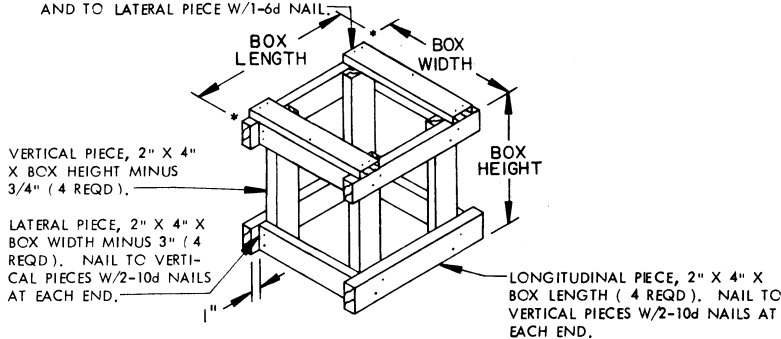

FILLER ASSEMBLY

(FOR MINUS ONE BOX)