

APPENDIX 99

UNITIZATION PROCEDURES FOR BOXED AMMUNITION AND COMPONENTS ON 4-WAY ENTRY PALLETS

SMOKE POT, M5, PACKED 1 PER PLYWOOD BOX, UNITIZED
36 BOXES PER 35" X 45 $\frac{1}{2}$ " PALLET; APPROX
BOX SIZE 12" L X 12" W X 13 $\frac{1}{8}$ " H

PALLET UNIT DATA						
ITEMS INCLUDED		HAZARD CLASSIFICATION ①				WEIGHT
NSN	DODIC	DOT CLASS	CG CLASS	QD CLASS	COMP GROUP	(LBS)
1365-00-598-5207	K866	C	II-E	1.3	G	1,765

REVISION

REVISION NO. 1, DATED JUNE 1986, CONSISTS OF:

1. CHANGING BOX DIMENSIONS.
2. CHANGING BOX TYPE.
3. UPDATING THE PALLET UNIT TO CONFORM TO 1 AND 2 ABOVE.

REVISION NO. 2, DATED OCTOBER 1987, CONSISTS OF:

ADDING GENERAL NOTE "K".

NOTICE: THIS APPENDIX CANNOT STAND ALONE BUT MUST BE USED IN CONJUNCTION WITH THE BASIC UNITIZATION PROCEDURES DRAWING 19-48-4116-20PA1002.

① HAZARD CLASSIFICATION DATA CONTAINED IN THE ABOVE CHART IS FOR GUIDANCE AND INFORMATIONAL PURPOSES ONLY. VERIFICATION OF THE SPECIFIED DATA SHOULD BE MADE BY CONSULTING THE MOST RECENT JOINT HAZARD CLASSIFICATION SYSTEM LISTING OR OTHER APPROVED LISTING (S).

REVISIONS				DRAFTSMAN R/oh	PROJ ENG G.B.F./hmm	(0034 20)
1	JUN 86	WLF	J.M. Thompson SMCAR-ESK AMDMC-TMD	RJA	LOG ENGRG OFFICE John Boyd	W.H. (R2)
2	OCT 87	WLF	William F. Ernst SMCAR-ESK AMDMC-TMD	APPROVED BY ORDER OF COMMANDING GENERAL, U. S. ARMY MATERIEL DEVELOPMENT AND READINESS COMMAND (DARCOM) John L. Boyd U. S. ARMY DEFENSE AMMUNITION CENTER AND SCHOOL		
U. S. ARMY DARCOM DRAWING						
JULY 1980						
CLASS	DIVISION	DRAWING	FILE			
19	48	4116/99	20PA 1002			

DO NOT SCALE

TIEDOWN STRAP, 3/4" X .035" OR .031" X 13'-8" LONG STEEL STRAPPING (4 REQD). SEE GENERAL NOTE "D" AT RIGHT.

SEAL FOR 3/4" STRAPPING (7 REQD, 1 PER STRAP). CRIMP EACH SEAL WITH TWO PAIR OF NOTCHES.

LOAD STRAP, 3/4" X .035" OR .031" X 15'-8" LONG STEEL STRAPPING (3 REQD). SEE GENERAL NOTE "C" AT RIGHT.

35" X 45-1/2" PALLET.

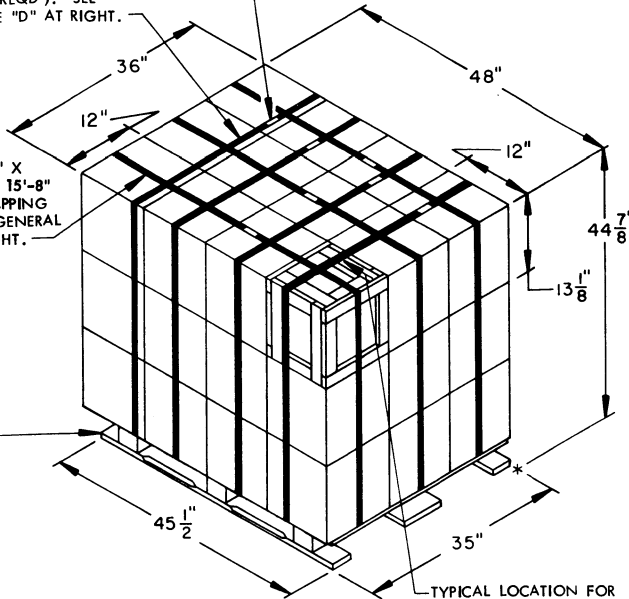

PALLET UNIT

SEE GENERAL NOTE "B" AT RIGHT.

36 BOXES OF SMOKE POT (1 PER BOX) @ 47 LBS ---- 1,692 LBS (APPROX)
 DUNNAGE ----- 8 LBS
 PALLET ----- 65 LBS

TOTAL WEIGHT ----- 1,765 LBS (APPROX)
 CUBE ----- 44.9 CU FT (APPROX)

BILL OF MATERIAL

PALLET, 35" X 45-1/2"-----	1 REQD -----	65 LBS
STEEL STRAPPING, 3/4"-----	101.67' REQD -----	7.26 LBS
SEAL FOR 3/4" STRAPPING-----	7 REQD -----	NIL

GENERAL NOTES

- A. THIS APPENDIX CANNOT STAND ALONE BUT MUST BE USED IN CONJUNCTION WITH THE BASIC UNITIZATION PROCEDURES DRAWING 19-48-4116-20PA1002. TO PRODUCE AN APPROVED UNIT LOAD, ALL PERTINENT PROCEDURES, SPECIFICATIONS AND CRITERIA SET FORTH WITHIN THE BASIC DRAWING WILL APPLY TO THE PROCEDURES DELINEATED IN THIS APPENDIX. ANY EXCEPTIONS TO THE BASIC PROCEDURES ARE SPECIFIED IN THIS APPENDIX.
- B. DIMENSIONS, CUBE AND WEIGHT OF A PALLET UNIT WILL VARY SLIGHTLY DEPENDING UPON THE ACTUAL DIMENSIONS OF THE BOXES AND THE WEIGHT OF THE SPECIFIC ITEM BEING UNITIZED.
- C. THE LOAD STRAPS MAY BE THREADED THROUGH THE STRAP SLOTS OF A PALLET OR PRE-POSITIONED ON THE PALLET DECK PRIOR TO PLACING BOXES ON THE PALLET. LOAD STRAPS MUST BE TENSIONED AND SEALED PRIOR TO APPLICATION OF TIEDOWN STRAPS.
- D. INSTALL EACH TIEDOWN STRAP TO PASS UNDER THE TOP DECK BOARDS OF THE PALLET AND TO BE LOCATED AS SHOWN. TIEDOWN STRAPS WILL NOT BE APPLIED UNTIL THE LOAD STRAPS HAVE BEEN TENSIONED AND SEALED.
- E. THE FOLLOWING AMC (DARCOM) DRAWINGS ARE APPLICABLE FOR OUTLOADING AND STORAGE OF THE ITEMS COVERED BY THIS APPENDIX.
 CARLOADING----- DRAWING 19-48-4115-5PA1002
 TRUCKLOADING -- DRAWING 19-48-4117-11PA1003
 STORAGE----- DRAWING 19-48-4118-1-2-3-4-14-22PA1002
- F. FOR METHOD OF SECURING A STRAP CUTTER TO THE PALLET UNIT, SEE DARCOM DRAWING 19-48-4127-20P1000.
- G. IF ITEMS COVERED HEREIN ARE UNITIZED PRIOR TO ISSUANCE OF THIS APPENDIX, THE BOXES NEED NOT BE REUNITIZED SOLELY TO CONFORM TO THIS APPENDIX.
- H. THE UNITIZATION PROCEDURES DEPICTED HEREIN MAY ALSO BE USED FOR UNITIZING SMOKE POTS WHEN IDENTIFIED BY DIFFERENT NATIONAL STOCK NUMBERS (NSN) THAN WHAT IS SHOWN ON THE TITLE PAGE, PROVIDED THE BOX PACK DOES NOT VARY FROM WHAT IS DELINEATED HEREIN. THE EXPLOSIVE CLASSIFICATION OF OTHER ITEMS MAY BE DIFFERENT THAN WHAT IS SHOWN.
- J. WHEN THE UNIT LOAD DEPICTED AT LEFT IS TO BE USED FOR UNITIZING MARINE CORPS AMMUNITION, 1 LAYER OF BOXES MUST BE OMITTED, TIEDOWN STRAP LENGTHS MUST BE DECREASED TO 11'-6", AND LOAD STRAP LENGTHS MUST BE DECREASED TO 13'-6". THIS WILL RESULT IN AN OVERALL UNIT HEIGHT OF 31-3/4", A GROSS UNIT WEIGHT OF 1,200 LBS, AND A UNIT CUBE OF 31.8 CU FT. ADDITIONALLY, THE UNIT LOAD MAY BE MODIFIED AS DESCRIBED WHEN BEING SHIPPED BY MILVAN OR COMMERCIAL INTERMODAL FREIGHT CONTAINER. THE DETERMINATION TO REDUCE THE LOAD BY A LAYER FOR TRANSPORTATION WILL BE MADE BY THE RESPONSIBLE COMMAND AND WILL BE BASED UPON ECONOMICS OF TRANSPORTATION AND HANDLING.
- K. THE STYLE 1A PALLET DELINEATED IN THE DETAIL AT LEFT NEED NOT HAVE CHAMFERS OR STRAP SLOTS AS SPECIFIED WITHIN MILITARY SPECIFICATION MIL-P-15011 WHEN USED FOR THE UNITIZATION OF THE ITEMS COVERED BY THIS APPENDIX.

SUPPORT PIECE, 2" X 4" X CUT-TO-FIT IN LENGTH (AS REQD). NAIL TO A VERTICAL PIECE W/2-10d NAILS. NOTE: IF A FILLER ASSEMBLY IS LOCATED IN AN OUTSIDE STACK ON A 45-1/2" SIDE OF THE PALLET, SUPPORT PIECES WILL BE REQUIRED AS SHOWN.

LONGITUDINAL PIECE, 2" X 4" X BOX WIDTH MINUS 3" (4 REQD). NAIL TO VERTICAL PIECES W/2-10d NAILS AT EACH END.

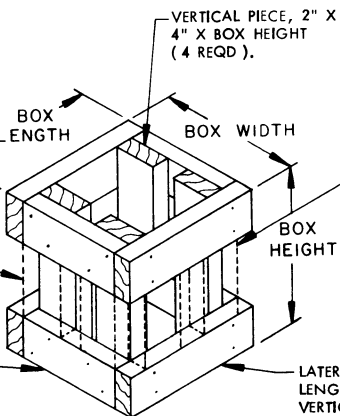

SUPPORT PIECE, 2" X 4" X CUT-TO-FIT IN LENGTH (AS REQD). NAIL TO A VERTICAL PIECE W/2-10d NAILS. NOTE: IF A FILLER ASSEMBLY IS LOCATED IN AN OUTSIDE STACK ON A 35" SIDE OF THE PALLET, SUPPORT PIECES WILL BE REQUIRED AS SHOWN.

LATERAL PIECE, 2" X 4" X BOX LENGTH (4 REQD), NAIL TO VERTICAL PIECES W/2-10d NAILS AT EACH END.

FILLER ASSEMBLY
 (FOR MINUS ONE BOX)