

## APPENDIX 96E

# UNITIZATION PROCEDURES FOR BOXED AMMUNITION AND COMPONENTS ON 4-WAY ENTRY PALLETS

FUZE, MINE, AT, M607 PACKED 100 PER WOODEN  
BOX, UNITIZED 12 BOXES PER 35" X 45 $\frac{1}{2}$ " PALLET;  
APPROX BOX SIZE 19 $\frac{1}{8}$ " L X 16 $\frac{13}{16}$ " W X 17 $\frac{19}{32}$ " H

| PALLET UNIT DATA     |       |                                    |             |             |               |                 |
|----------------------|-------|------------------------------------|-------------|-------------|---------------|-----------------|
| ITEMS INCLUDED       |       | HAZARD CLASSIFICATION <sup>①</sup> |             |             |               | WEIGHT<br>(LBS) |
| NSN                  | DODIC | DOT<br>CLASS                       | CG<br>CLASS | QD<br>CLASS | COMP<br>GROUP |                 |
| 1345-<br>00-828-7458 | ----  | C                                  | III         | 1.4         | D             | 1,055           |

① HAZARD CLASSIFICATION DATA CONTAINED IN THE ABOVE CHART IS FOR GUIDANCE AND INFORMATIONAL PURPOSES ONLY. VERIFICATION OF THE SPECIFIED DATA SHOULD BE MADE BY CONSULTING THE MOST RECENT JOINT HAZARD CLASSIFICATION SYSTEM LISTING OR OTHER APPROVED LISTING (S).

**NOTICE:** THIS APPENDIX CANNOT STAND ALONE BUT MUST BE USED IN CONJUNCTION WITH THE BASIC UNITIZATION PROCEDURES DRAWING 19-48-4116-20PA1002.

| REVISIONS |          |              |              | DRAFTSMAN<br>dh  | PROJ ENG<br>LAE/WRE                                       |
|-----------|----------|--------------|--------------|--|---|
|           |          |              |              | WJG  | WJG   |
|           |          |              |              | APPROVED BY ORDER OF COMMANDING GENERAL, U.S. ARMY<br>MATERIAL COMMAND (AMC) | APPROVED BY ORDER OF COMMANDING GENERAL, U.S. ARMY<br>AMC |
|           |          |              |              | <i>John H. Martin</i>  | <i>S. J. Johnson</i>                                      |
|           |          |              |              | U.S. ARMY AMC DRAWING  |   |
|           |          |              |              | JUNE 1986  |   |
| CLASS     | DIVISION | DRAWING      | FILE         |  |   |
| 19        | 48       | 4116/<br>96E | 20PA<br>1002 |  |   |

**DO NOT SCALE**

**GENERAL NOTES**

- A. THIS APPENDIX CANNOT STAND ALONE BUT MUST BE USED IN CONJUNCTION WITH THE BASIC UNITIZATION PROCEDURES DRAWING 19-48-4116-20PA1002. TO PRODUCE AN APPROVED UNIT LOAD, ALL PERTINENT PROCEDURES, SPECIFICATIONS AND CRITERIA SET FORTH WITHIN THE BASIC DRAWING WILL APPLY TO THE PROCEDURES DELINEATED IN THIS APPENDIX. ANY EXCEPTIONS TO THE BASIC PROCEDURES ARE SPECIFIED IN THIS APPENDIX.
- B. DIMENSIONS, CUBE AND WEIGHT OF A PALLET UNIT WILL VARY SLIGHTLY DEPENDING UPON THE ACTUAL DIMENSIONS OF THE BOXES AND THE WEIGHT OF THE SPECIFIC ITEM BEING UNITIZED.
- C. THE LOAD STRAPS MAY BE THREADED THROUGH THE STRAP SLOTS OF A PALLET OR PRE-POSITIONED ON THE PALLET DECK PRIOR TO PLACING BOXES ON THE PALLET. LOAD STRAPS MUST BE TENSIONED AND SEALED PRIOR TO APPLICATION OF TIEDOWN STRAPS.
- D. INSTALL EACH TIEDOWN STRAP TO PASS UNDER THE TOP DECK/ STRINGER BOARDS OF THE PALLET AND TO BE LOCATED AS SHOWN. TIEDOWN STRAPS WILL NOT BE APPLIED UNTIL THE LOAD STRAPS HAVE BEEN TENSIONED AND SEALED.
- E. THE FOLLOWING AMC (DARCOM) DRAWINGS ARE APPLICABLE FOR OUTLOADING AND STORAGE OF THE ITEMS COVERED BY THIS APPENDIX.  
 CARLOADING-----DRAWING 19-48-4115-5PA1002  
 TRUCKLOADING -- DRAWING 19-48-4117-11PA1003  
 STORAGE-----DRAWING 19-48-4118-1-2-3-4-14-22PA1002
- F. FOR METHOD OF SECURING A STRAP CUTTER TO THE PALLET UNIT, SEE DARCOM DRAWING 19-48-4127-20P1000.
- G. IF ITEMS COVERED HEREIN ARE UNITIZED PRIOR TO ISSUANCE OF THIS APPENDIX, THE BOXES NEED NOT BE REUNITIZED SOLELY TO CONFORM TO THIS APPENDIX.
- H. THE UNITIZATION PROCEDURES DEPICTED HEREIN MAY ALSO BE USED FOR UNITIZING MINE FUZZES WHEN IDENTIFIED BY DIFFERENT NATIONAL STOCK NUMBERS (NSN) THAN WHAT IS SHOWN ON THE TITLE PAGE, PROVIDED THE BOX PACK DOES NOT VARY FROM WHAT IS DELINEATED HEREIN. THE EXPLOSIVE CLASSIFICATION OF OTHER ITEMS MAY BE DIFFERENT THAN WHAT IS SHOWN.

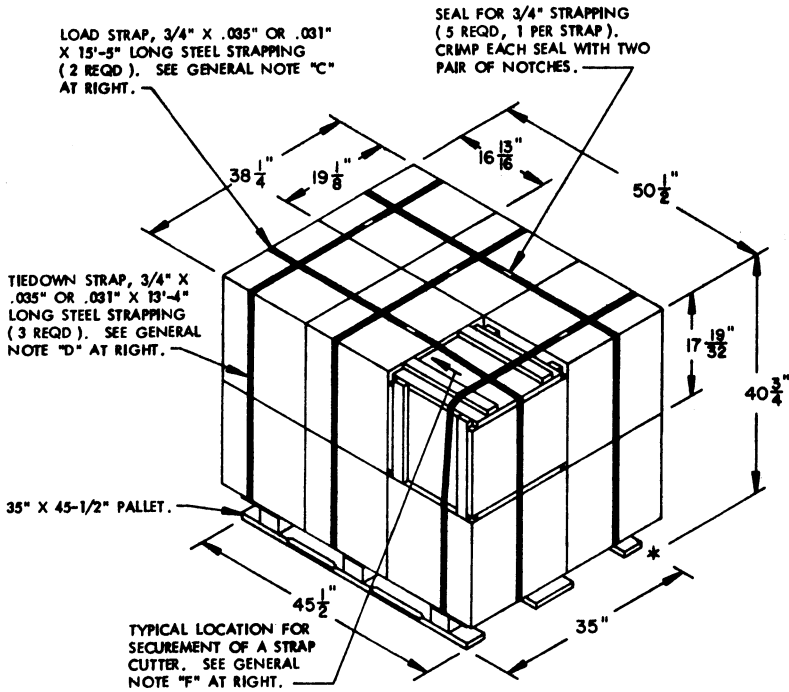

**PALLET UNIT**

(SEE GENERAL NOTE "B" AT RIGHT)

|  |                            |
|--|----------------------------|
| 12 BOXES OF MINE FUZZES (100 PER BOX) @ 82 LBS | 984 LBS (APPROX)           |
| DUNNAGE  | 6 LBS                      |
| PALLET   | 65 LBS                     |
| <b>TOTAL WEIGHT</b>                            | <b>1,055 LBS (APPROX)</b>  |
| <b>CUBE</b>                                    | <b>45.6 CU FT (APPROX)</b> |

**BILL OF MATERIAL**

|                         |             |          |
|-------------------------|-------------|----------|
| PALLET, 35" X 45-1/2"   | 1 REQD      | 65 LBS   |
| STEEL STRAPPING, 3/4"   | 70.83' REQD | 5.06 LBS |
| SEAL FOR 3/4" STRAPPING | 5 REQD      | NIL      |

