

# APPENDIX 96A

## UNITIZATION PROCEDURES FOR BOXED AMMUNITION AND COMPONENTS ON 4-WAY ENTRY PALLETS

FUZE, MINE, COMBINATION, PACKED 48 PER WOODEN  
BOX, UNITIZED 24 BOXES PER 35" X 45 $\frac{1}{2}$ " PALLET;  
APPROX BOX SIZE 22 $\frac{5}{8}$ " L X 10 $\frac{3}{8}$ " W X 9 $\frac{3}{8}$ " H

PALLET UNIT DATA						
ITEMS INCLUDED		HAZARD CLASSIFICATION				WEIGHT
NSN	DODIC	DOT CLASS	CG CLASS	OD CLASS	COMP GROUP	( LBS )
1345-00						
028-5079	K054	C	III	( 04 ) 1.2	B	864
028-5080	K053	C	III	( 04 ) 1.2	B	864

NOTICE: THIS APPENDIX CANNOT STAND ALONE BUT MUST BE  
USED IN CONJUNCTION WITH THE BASIC UNITIZATION PROCEDURES  
DRAWING 19-48-4116-20PA1002.

REVISIONS				DRAFTSMAN	PROJ. ENG.
				<i>P&amp;B</i>	<i>MBK</i>
				CHECKER	LOG ENGRG OFFICE
				<i>RSH</i>	<i>John Bond</i>
APPROVED, U. S. ARMY ARMAMENT MATERIEL READINESS COMMAND					
				<i>W. B. Benton</i>	<i>David C. Fetter</i>
				DRAWN - M/D	DRBAR - TMD
APPROVED BY ORDER OF COMMANDING GENERAL, U. S. ARMY MATERIEL DEVELOPMENT AND READINESS COMMAND (DARCOM)					
<i>John A. Synolt</i>					
U. S. ARMY DEFENSE AMMUNITION CENTER AND SCHOOL					
U. S. ARMY DARCOM DRAWING					
DECEMBER 1980					
CLASS	DIVISION	DRAWING	FILE		
19	48	4116/96A	20PA 1002		

**DO NOT SCALE**

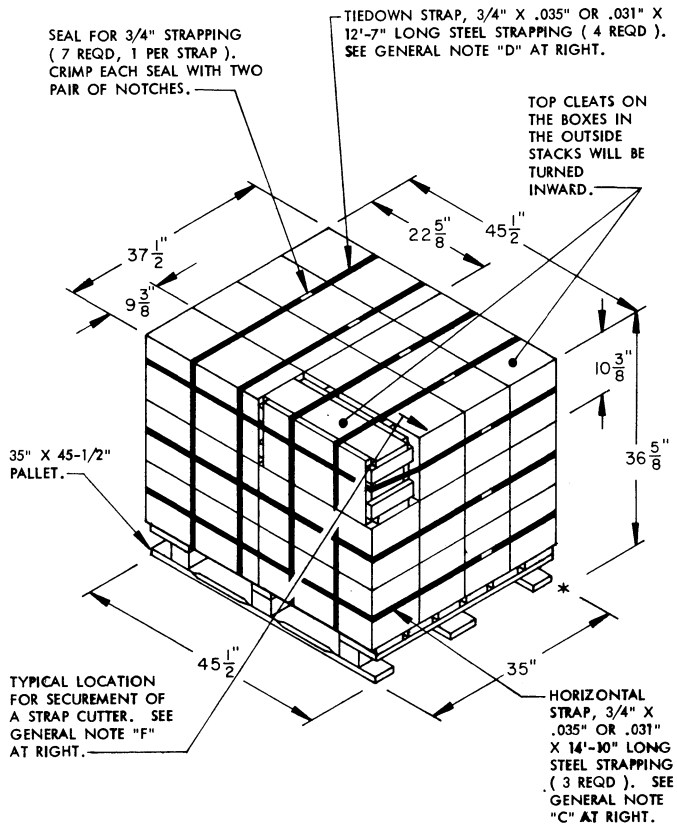

**GENERAL NOTES**

- A. THIS APPENDIX CANNOT STAND ALONE BUT MUST BE USED IN CONJUNCTION WITH THE BASIC UNITIZATION PROCEDURES DRAWING 19-48-4116-20PA1002. TO PRODUCE AN APPROVED UNIT LOAD, ALL PERTINENT PROCEDURES, SPECIFICATIONS AND CRITERIA SET FORTH WITHIN THE BASIC DRAWING WILL APPLY TO THE PROCEDURES DELINEATED IN THIS APPENDIX. ANY EXCEPTIONS TO THE BASIC PROCEDURES ARE SPECIFIED IN THIS APPENDIX.
- B. DIMENSIONS, CUBE AND WEIGHT OF A PALLET UNIT WILL VARY SLIGHTLY DEPENDING UPON THE ACTUAL DIMENSIONS OF THE BOXES AND THE WEIGHT OF THE SPECIFIC ITEM BEING UNITIZED.
- C. INSTALL EACH HORIZONTAL STRAP TO ENCIRCLE EACH LAYER OF BOXES ON THE PALLET. HORIZONTAL STRAPS MUST BE TENSIONED AND SEALED PRIOR TO APPLICATION OF TIEDOWN STRAPS.
- D. INSTALL EACH TIEDOWN STRAP TO PASS UNDER THE TOP DECK BOARDS OF THE PALLET AND TO BE LOCATED AS SHOWN. TIEDOWN STRAPS WILL NOT BE APPLIED UNTIL THE HORIZONTAL STRAPS HAVE BEEN TENSIONED AND SEALED.
- E. THE FOLLOWING DARCOM DRAWINGS ARE APPLICABLE FOR OUTLOADING AND STORAGE OF THE ITEMS COVERED BY THIS APPENDIX.
  - CARLOADING ----- DRAWING 19-48-4115-5PA1002
  - TRUCKLOADING ----- DRAWING 19-48-4117-11PA1003
  - STORAGE ----- DRAWING 19-48-4118-1-2-14-22PA1002
- F. FOR METHOD OF SECURING A STRAP CUTTER TO THE PALLET UNIT, SEE DARCOM DRAWING 19-48-4127-20P1000.
- G. IF ITEMS COVERED HEREIN ARE UNITIZED PRIOR TO ISSUANCE OF THIS APPENDIX, THE BOXES NEED NOT BE REUNITIZED SOLELY TO CONFORM TO THIS APPENDIX.
- H. THE UNITIZATION PROCEDURES DEPICTED HEREIN MAY ALSO BE USED FOR UNITIZING MINE FUZZES WHEN IDENTIFIED BY DIFFERENT NATIONAL STOCK NUMBERS ( NSN ) THAN WHAT IS SHOWN ON THE TITLE PAGE, PROVIDED THE BOX PACK DOES NOT VARY FROM WHAT IS DELINEATED HEREIN. THE EXPLOSIVE CLASSIFICATION OF OTHER ITEMS MAY BE DIFFERENT THAN WHAT IS SHOWN.

**PALLET UNIT**

SEE GENERAL NOTE "B" AT RIGHT.

24 BOXES OF FUZE, MINE ( 48 PER BOX ) @ 33 LBS -----	792 LBS ( APPROX )
DUNNAGE -----	7 LBS
PALLET -----	65 LBS
<b>TOTAL WEIGHT -----</b>	<b>864 LBS ( APPROX )</b>
<b>CUBE -----</b>	<b>36.2 CU FT ( APPROX )</b>

**BILL OF MATERIAL**

PALLET, 35" X 45-1/2" -----	1 REQD -----	65 LBS
STEEL STRAPPING, 3/4" -----	94.83 REQD -----	6.77 LBS
SEAL FOR 3/4" STRAPPING -----	7 REQD -----	NIL

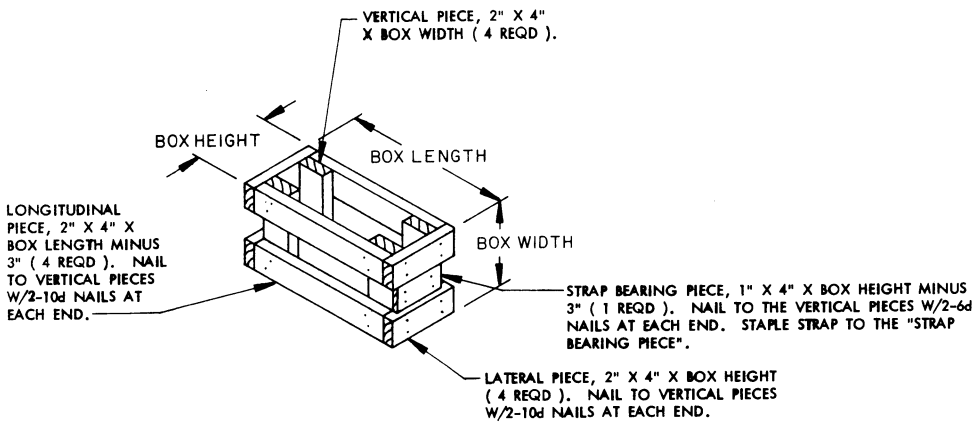

**FILLER ASSEMBLY**

( FOR MINUS ONE BOX )