

APPENDIX 95S

UNITIZATION PROCEDURES FOR BOXED AMMUNITION AND COMPONENTS ON 4-WAY ENTRY PALLETS

MINE, ANTI-PERSONNEL, M14, 90 PER BOX,
UNITIZED 30 BOXES PER 40" X 48" PALLET;
APPROX BOX SIZE 20" L X 17-9/16" W X
8-15/16" H

NOTICE: THIS APPENDIX CANNOT STAND ALONE BUT MUST BE USED IN CONJUNCTION WITH
THE BASIC UNITIZATION PROCEDURES DRAWING 19-48-4116-20PA1002.

DISTRIBUTION STATEMENT A.

APPROVED FOR PUBLIC RELEASE:
DISTRIBUTION IS UNLIMITED.

U. S. ARMY MATERIEL COMMAND DRAWING			
APPROVED, U.S. ARMY INDUSTRIAL OPERATIONS COMMAND <i>D. Pichouil</i> <i>Timothy Fore</i> AMSTA-AR-ESK AMSIO-TM.J	DRAFTSMAN	BETTY J. KUNDERT	
	ENGINEER	SANDRA M. SCHULTZ	
	SUPPLY ENGINEERING DIVISION	TRANSPORTATION ENGINEERING DIVISION	VALIDATION ENGINEERING DIVISION
	<i>T. J. Meehan</i>	<i>W. D. Smith</i>	<i>J. K. Kuhn</i>
APPROVED BY ORDER OF COMMANDING GENERAL, U.S. ARMY MATERIEL COMMAND <i>Larry V. Dullidge</i> U.S. ARMY DEFENSE AMMUNITION CENTER	LOGISTICS ENGINEERING OFFICE <i>William F. Ernst</i>		
	JANUARY 1997		
	CLASS	DIVISION	DRAWING
	19	48	4116/ 95S
			FILE
			20PA 1002

DO NOT SCALE

PALLET UNIT DATA				
ITEMS INCLUDED		HAZARD CLASS AND DIVISION		APPROX WEIGHT LBS
NSN	DODIC	OD CLASS	COMP GROUP	
1345-				
00-028-5108	K121	1.1	D	1,588
00-096-3093	K121	1.1	D	1,588

● HAZARD CLASSIFICATION DATA CONTAINED IN THE ABOVE CHART IS FOR GUIDANCE AND INFORMATIONAL PURPOSES ONLY. VERIFICATION OF THE SPECIFIED DATA SHOULD BE MADE BY CONSULTING THE MOST RECENT JOINT HAZARD CLASSIFICATION SYSTEM LISTING OR OTHER APPROVED LISTING(S).

GENERAL NOTES

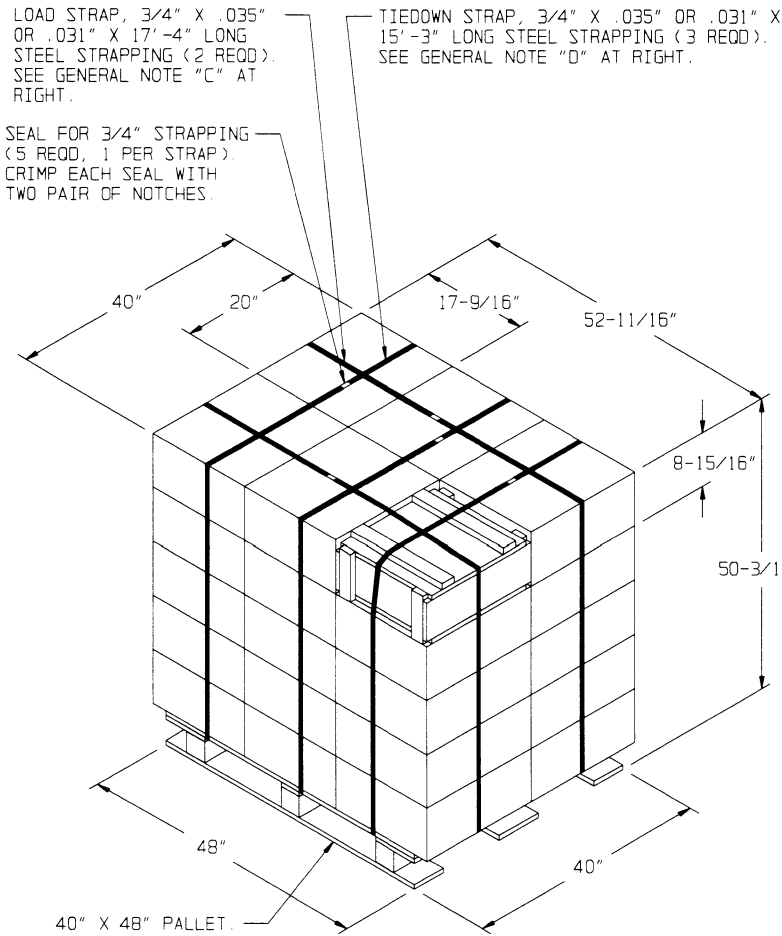

PALLET UNIT

SEE GENERAL NOTE "B" AT RIGHT.

30 BOXES OF M14 MINES (90 PER BOX) AT 50 LBS	1,500 LBS (APPROX)
DUNNAGE	8 LBS
PALLET	80 LBS
TOTAL WEIGHT	1,588 LBS (APPROX)
CUBE	61.2 CU FT (APPROX)

BILL OF MATERIAL

PALLET, 40" X 48"	1 REOD	80 LBS
STEEL STRAPPING, 3/4"	80.42' REOD	7.18 LBS
SEAL FOR 3/4" STRAPPING	5 REOD	NIL

- A. THIS APPENDIX CANNOT STAND ALONE BUT MUST BE USED IN CONJUNCTION WITH THE BASIC UNITIZATION PROCEDURES DRAWING 19-48-4116-20PA1002. TO PRODUCE AN APPROVED UNIT LOAD, ALL PERTINENT PROCEDURES, SPECIFICATIONS AND CRITERIA SET FORTH WITHIN THE BASIC DRAWING WILL APPLY TO THE PROCEDURES DELINEATED IN THIS APPENDIX. ANY EXCEPTIONS TO THE BASIC PROCEDURES ARE SPECIFIED IN THIS APPENDIX.
- B. DIMENSIONS, CUBE AND WEIGHT OF A PALLET UNIT WILL VARY SLIGHTLY DEPENDING UPON THE ACTUAL DIMENSIONS OF THE BOXES AND THE WEIGHT OF THE SPECIFIC ITEM BEING UNITIZED.
- C. THE LOAD STRAPS MAY BE THREADED THROUGH THE STRAP SLOTS OF A PALLET OR PRE-POSITIONED ON THE PALLET DECK PRIOR TO PLACING BOXES ON THE PALLET. LOAD STRAPS MUST BE TENSIONED AND SEALED PRIOR TO APPLICATION OF TIEDOWN STRAPS.
- D. INSTALL EACH TIEDOWN STRAP TO PASS UNDER THE DECK BOARDS OF THE PALLET AND TO BE LOCATED AS SHOWN. TIEDOWN STRAPS WILL NOT BE APPLIED UNTIL THE LOAD STRAPS HAVE BEEN TENSIONED AND SEALED.
- E. THE FOLLOWING AMC DRAWINGS ARE APPLICABLE FOR OUTLOADING AND STORAGE OF THE ITEMS COVERED BY THIS APPENDIX.
 - CARLOADING - - - - 19-48-4115-5PA1002
 - TRUCKLOADING - - - - 19-48-4117-11PA1003
 - STORAGE - - - - 19-48-4118-1-2-3-4-14-22PA1002
 - END OPENING ISO
 - CONTAINER - - - - 19-48-4153-15PA1002
 - MILVAN - - - - 19-48-4166-15PA1003
 - SIDE OPENING ISO
 - CONTAINER - - - - 19-48-4267-15PA1009
- F. IF ITEMS COVERED HEREIN ARE UNITIZED PRIOR TO ISSUANCE OF THIS APPENDIX, THE BOXES NEED NOT BE REUNITIZED SOLELY TO CONFORM TO THIS APPENDIX
- G. THE UNITIZATION PROCEDURES DEPICTED HEREIN MAY ALSO BE USED FOR UNITIZING M14 MINES WHEN IDENTIFIED BY DIFFERENT NATIONAL STOCK NUMBERS (NSN) THAN WHAT IS SHOWN ON PAGE 2, PROVIDED THE BOX PACK DOES NOT VARY FROM WHAT IS DELINEATED HEREIN. THE EXPLOSIVE CLASSIFICATION OF OTHER ITEMS MAY BE DIFFERENT THAN WHAT IS SHOWN.
- H. THE STYLE 1 PALLET DELINEATED IN THE DETAIL AT LEFT NEED NOT HAVE CHAMFERS OR STRAP SLOTS AS SPECIFIED WITHIN MILITARY SPECIFICATION MIL-P-15011 WHEN USED FOR THE UNITIZATION OF ITEMS COVERED BY THIS APPENDIX.
- J. FOR DETAILS OF THE MIL-B-2427 WOODEN BOX SEE DRAWING 8861849.

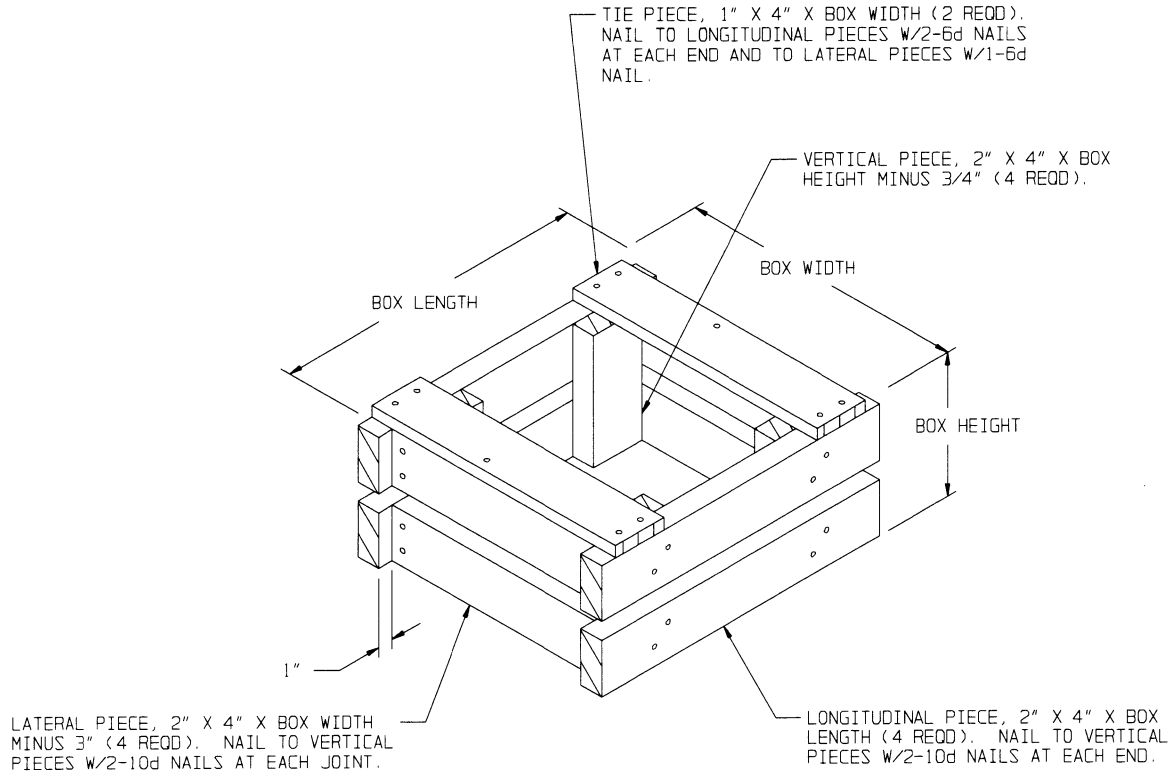

FILLER ASSEMBLY
(FOR MINUS ONE BOX)