

APPENDIX 95E

UNITIZATION PROCEDURES FOR BOXED AMMUNITION AND COMPONENTS ON 4-WAY ENTRY PALLETS

MINE, ANTITANK, PACKED 2 PER WOODEN BOX,
UNITIZED 40 BOXES PER 40" X 48" PALLET;
APPROX BOX SIZE $13\frac{1}{2}$ " L X $8\frac{5}{8}$ " W X $13\frac{5}{16}$ " H

PALLET UNIT DATA						
ITEMS INCLUDED		HAZARD CLASSIFICATION				WEIGHT (LBS)
NSN	DODIC	DOT CLASS	CG CLASS	QD CLASS	COMP GROUP	
1345-00-799-7390	K242	—	—	—	—	3,087

NOTICE: THIS APPENDIX CANNOT STAND ALONE BUT MUST
BE USED IN CONJUNCTION WITH THE BASIC UNITIZATION
PROCEDURES DRAWING 19-48-4116-20PA1002.

REVISIONS				DRAFTSMAN B.L.	PROJ ENG WRE/MLW
				CHECKED SES	LOG ENGINE OFFICE W. H. Condit
				APPROVED, U. S. ARMY ARMAMENT MATERIEL READINESS COMMAND	
				<i>[Signature]</i> DWSAR - LEP	
				APPROVED BY ORDER OF COMMANDING GENERAL, U. S. ARMY MATERIEL DEVELOPMENT AND READINESS COMMAND (DARCOM)	
				<i>[Signature]</i> U. S. ARMY DEFENSE AMMUNITION CENTER AND SCHOOL	
				U. S. ARMY DARCOM DRAWING	
				JUNE 1981	
	CLASS	DIVISION	DRAWING	FILE	
	19	48	4116/ 95E	20PA 1002	

DO NOT SCALE

SEAL FOR 3/4" STRAPPING
(6 REQ'D, 1 PER STRAP).
CRIMP EACH SEAL WITH TWO
PAIR OF NOTCHES.

TIEDOWN STRAP, 3/4" X .035"
OR .031" X 12'-9" LONG STEEL
STRAPPING (4 REQ'D). SEE
GENERAL NOTE "D" AT RIGHT.

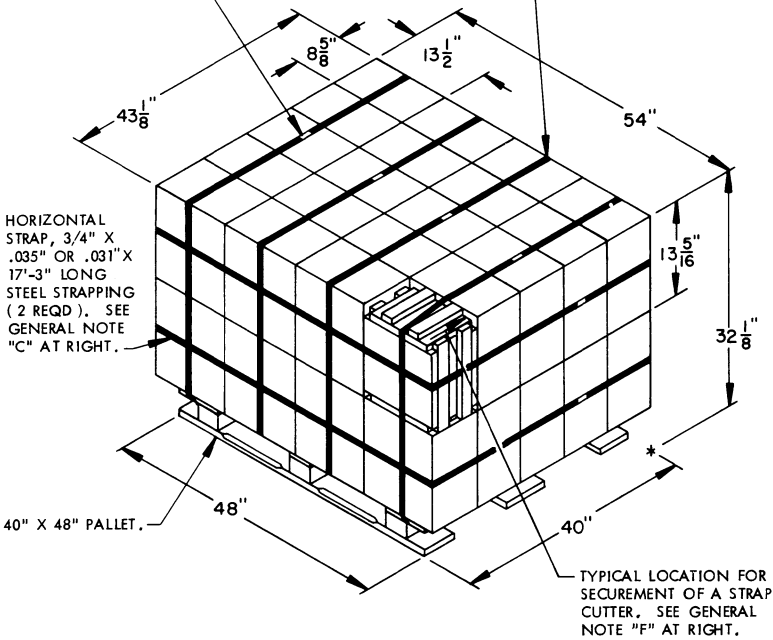

PALLET UNIT

SEE GENERAL NOTE "B" AT RIGHT

40 BOXES OF MINES (2 PER BOX) @ 75 LBS ----- 3,000 LBS (APPROX)
DUNNAGE ----- 7 LBS
PALLET ----- 80 LBS

TOTAL WEIGHT ----- 3,087 LBS (APPROX)
CUBE ----- 43.3 CU FT (APPROX)

BILL OF MATERIAL

PALLET -----	1	REQD -----	80 LBS
STEEL STRAPPING, 3/4" -----	85.50	REQD -----	6.11 LBS
SEAL FOR 3/4" STRAPPING -----	2	REQD -----	NIL

GENERAL NOTES

- A. THIS APPENDIX CANNOT STAND ALONE BUT MUST BE USED IN CONJUNCTION WITH THE BASIC UNITIZATION PROCEDURES DRAWING 19-48-4116-20PA1002. TO PRODUCE AN APPROVED UNIT LOAD, ALL PERTINENT PROCEDURES, SPECIFICATIONS AND CRITERIA SET FORTH WITHIN THE BASIC DRAWING WILL APPLY TO THE PROCEDURES DELINEATED IN THIS APPENDIX. ANY EXCEPTIONS TO THE BASIC PROCEDURES ARE SPECIFIED IN THIS APPENDIX.
- B. DIMENSIONS, CUBE AND WEIGHT OF A PALLET UNIT WILL VARY SLIGHTLY DEPENDING UPON THE ACTUAL DIMENSIONS OF THE BOXES AND THE WEIGHT OF THE SPECIFIC ITEM BEING UNITIZED.
- C. INSTALL EACH HORIZONTAL STRAP TO ENCIRCLE EACH LAYER OF BOXES AS SHOWN. HORIZONTAL STRAPS MUST BE TENSIONED AND SEALED PRIOR TO APPLICATION OF TIEDOWN STRAPS.
- D. INSTALL EACH TIEDOWN STRAP TO PASS UNDER THE DECK/STRINGER BOARDS OF THE PALLET AND TO BE LOCATED AS SHOWN. TIEDOWN STRAPS WILL NOT BE APPLIED UNTIL THE HORIZONTAL STRAPS HAVE BEEN TENSIONED AND SEALED.
- E. THE FOLLOWING DARCOM DRAWINGS ARE APPLICABLE FOR OUTLOADING AND STORAGE OF THE ITEMS COVERED BY THIS APPENDIX.
 - CARLOADING ----- DRAWING 19-48-4115-5PA1002
 - TRUCKLOADING ----- DRAWING 19-48-4117-11PA1003
 - STORAGE ----- DRAWING 19-48-4118-1-2-3-4-14-22 PA1002
- F. FOR METHOD OF SECURING A STRAP CUTTER TO THE PALLET UNIT, SEE DARCOM DRAWING 19-48-4127-20P1000.
- G. IF ITEMS COVERED HEREIN ARE UNITIZED PRIOR TO ISSUANCE OF THIS APPENDIX, THE BOXES NEED NOT BE REUNITIZED SOLELY TO CONFORM TO THIS APPENDIX.
- H. THE UNITIZATION PROCEDURES DEPICTED HEREIN MAY ALSO BE USED FOR UNITIZING MINES WHEN IDENTIFIED BY DIFFERENT NATIONAL STOCK NUMBERS (NSN) THAN WHAT IS SHOWN ON THE TITLE PAGE, PROVIDED THE BOX PACK DOES NOT VARY FROM WHAT IS DELINEATED HEREIN. THE EXPLOSIVE CLASSIFICATION OF OTHER ITEMS MAY BE DIFFERENT THAN WHAT IS SHOWN.

TIE PIECE, 1" X 4" X BOX WIDTH
(2 REQ'D). NAIL TO LONGITUDINAL
PIECES W/2-6d NAILS AT EACH END
AND TO LATERAL PIECES W/1-6d NAILS.

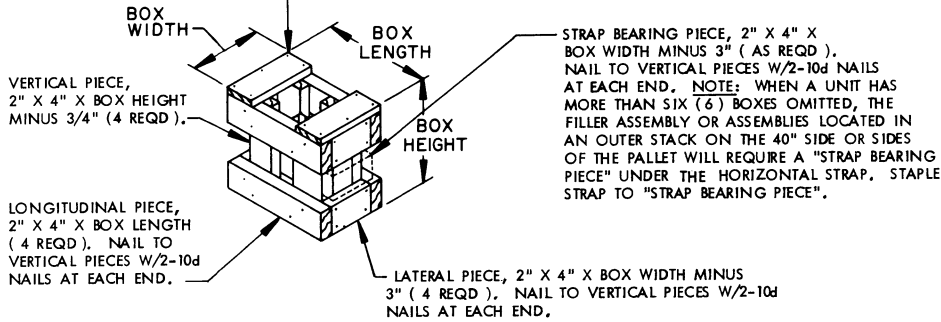

FILLER ASSEMBLY
(FOR MINUS ONE BOX)