

APPENDIX 95D

UNITIZATION PROCEDURES FOR BOXED AMMUNITION AND COMPONENTS ON 4-WAY ENTRY PALLETS

MINE, ANTITANK, PACKED 2 PER WOODEN BOX,
UNITIZED 36 BOXES PER 40" X 48" PALLET;
APPROX BOX SIZE 16 $\frac{1}{4}$ " L X 10 $\frac{5}{8}$ " W X 16" H

PALLET UNIT DATA						
ITEMS INCLUDED		HAZARD CLASSIFICATION ^①				WEIGHT (LBS)
NSN	DODIC	DOT CLASS	CG CLASS	QD CLASS	COMP GROUP	
1345- 00-324-1425 00-348-8646	K250	A	VII	1.1	D	2,679
	K250	A	VII	1.1	D	2,679

NOTICE: THIS APPENDIX CANNOT STAND ALONE BUT MUST
BE USED IN CONJUNCTION WITH THE BASIC UNITIZATION
PROCEDURES DRAWING 19-48-4116-20PA1002.

① HAZARD CLASSIFICATION DATA CONTAINED IN THE ABOVE CHART
IS FOR GUIDANCE AND INFORMATIONAL PURPOSES ONLY. VERI-
FICATION OF THE SPECIFIED DATA SHOULD BE MADE BY CONSULTING
THE MOST RECENT JOINT HAZARD CLASSIFICATION SYSTEM LISTING
OR OTHER APPROVED LISTING(S).

REVISIONS				DRAFTSMAN <i>[Signature]</i>	PROJ ENG <i>[Signature]</i>
				CHECKER <i>[Signature]</i>	LOG ENGINE OFFICE <i>[Signature]</i>
APPROVED, U. S. ARMY ARMAMENT, MUNITIONS AND CHEMICAL COMMAND					
<i>[Signature]</i> DRMCC - LEP					
APPROVED BY ORDER OF COMMANDING GENERAL, U. S. ARMY MATERIEL DEVELOPMENT AND READINESS COMMAND (DARCOM)					
<i>[Signature]</i> U. S. ARMY DEFENSE AMMUNITION CENTER AND SCHOOL					
U. S. ARMY DARCOM DRAWING					
NOVEMBER 1983					
CLASS	DIVISION	DRAWING	FILE		
19	48	4116/95D	20PA 1002		

DO NOT SCALE

GENERAL NOTES

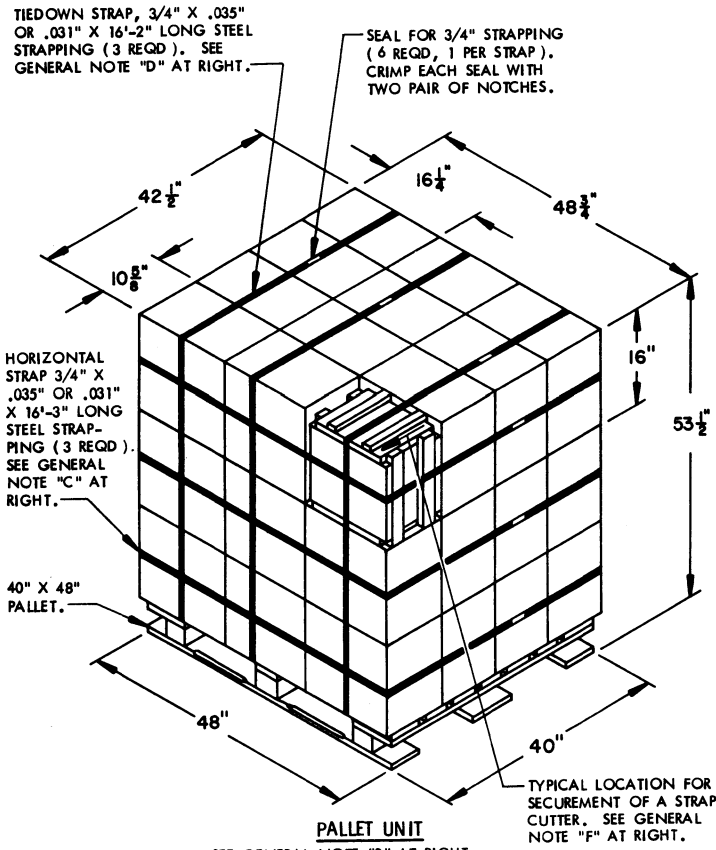

- A. THIS APPENDIX CANNOT STAND ALONE BUT MUST BE USED IN CONJUNCTION WITH THE BASIC UNITIZATION PROCEDURES DRAWING 19-48-4116-20PA1002. TO PRODUCE AN APPROVED UNIT LOAD, ALL PERTINENT PROCEDURES, SPECIFICATIONS AND CRITERIA SET FORTH WITHIN THE BASIC DRAWING WILL APPLY TO THE PROCEDURES DELINEATED IN THIS APPENDIX. ANY EXCEPTIONS TO THE BASIC PROCEDURES ARE SPECIFIED IN THIS APPENDIX.
- B. DIMENSIONS, CUBE AND WEIGHT OF A PALLET UNIT WILL VARY SLIGHTLY DEPENDING UPON THE ACTUAL DIMENSIONS OF THE BOXES AND THE WEIGHT OF THE SPECIFIC ITEM BEING UNITIZED.
- C. INSTALL EACH HORIZONTAL STRAP TO ENCIRCLE A LAYER OF BOXES ON THE PALLET. HORIZONTAL STRAPS MUST BE TENSIONED AND SEALED PRIOR TO APPLICATION OF TIEDOWN STRAPS.
- D. INSTALL EACH TIEDOWN STRAP TO PASS UNDER THE TOP DECK BOARDS OF THE PALLET AND TO BE LOCATED AS SHOWN. TIEDOWN STRAPS WILL NOT BE APPLIED UNTIL THE HORIZONTAL STRAPS HAVE BEEN TENSIONED AND SEALED.
- E. THE FOLLOWING DARCOM DRAWINGS ARE APPLICABLE FOR OUTLOADING AND STORAGE OF THE ITEMS COVERED BY THIS APPENDIX.

CARLOADING -----	DRAWING 19-48-4115-5PA1002
TRUCKLOADING -----	DRAWING 19-48-4117-11PA1003
STORAGE -----	DRAWING 19-48-4118-1-2-3-4-24-22PA 1002
- F. FOR METHOD OF SECURING A STRAP CUTTER TO THE PALLET UNIT, SEE DARCOM DRAWING 19-48-4127-20P1000.
- G. IF ITEMS COVERED HEREIN ARE UNITIZED PRIOR TO ISSUANCE OF THIS APPENDIX, THE BOXES NEED NOT BE REUNITIZED SOLELY TO CONFORM TO THIS APPENDIX.
- H. THE UNITIZATION PROCEDURES DEPICTED HEREIN MAY ALSO BE USED FOR UNITIZING ANTITANK MINES WHEN IDENTIFIED BY DIFFERENT NATIONAL STOCK NUMBERS (NSN) THAN WHAT IS SHOWN ON THE TITLE PAGE, PROVIDED THE BOX PACK DOES NOT VARY FROM WHAT IS DELINEATED HEREIN. THE EXPLOSIVE CLASSIFICATION OF OTHER ITEMS MAY BE DIFFERENT THAN WHAT IS SHOWN.
- J. WHEN THE UNIT LOAD DEPICTED AT LEFT IS TO BE USED FOR UNITIZING MARINE CORPS AMMUNITION, 1 LAYER OF BOXES MUST BE OMITTED, TIEDOWN STRAP LENGTHS MUST BE DECREASED TO 13'-6", AND ONE HORIZONTAL STRAP MUST BE DELETED. THIS WILL RESULT IN AN OVERALL UNIT HEIGHT OF 37'-1/2", A GROSS UNIT WEIGHT OF 1,814 LBS, AND A UNIT CUBE OF 45.0 CU FT. ADDITIONALLY, THE UNIT LOAD MAY BE MODIFIED AS DESCRIBED WHEN BEING SHIPPED BY MILVAN OR COMMERCIAL INTERMODAL FREIGHT CONTAINER, CONVENTIONAL VAN TRAILER OR CONVENTIONAL OR HIGH-CAPACITY BOXCAR. THE DETERMINATION TO REDUCE THE LOAD BY A LAYER FOR TRANSPORTATION WILL BE MADE BY THE RESPONSIBLE COMMAND AND WILL BE BASED UPON ECONOMICS OF TRANSPORTATION AND HANDLING.

36 BOXES OF MINES (2 PER BOX) @ 72 LBS -----	2,592 LBS (APPROX)
DUNNAGE -----	7 LBS
PALLET -----	80 LBS
TOTAL WEIGHT -----	2,679 LBS (APPROX)
CUBE -----	64.2 CU FT (APPROX)

BILL OF MATERIAL		
PALLET, 40" X 48" -----	1 REQD -----	80 LBS
STEEL STRAPPING, 3/4" -----	97.25' REQD -----	6.95 LBS
SEAL FOR 3/4" STRAPPING -----	6 REQD -----	NIL

